



Count on it.

Parts Catalog

**Z Master[®] Riding Mower
with 72in TURBO FORCE[®] Side Discharge
Mower**

Model No. 74977—Serial No. 312000001 and Up



Ordering Replacement Parts

To order replacement parts, please supply the part number, the quantity, and the description of each part desired.

Understanding Reference Numbers

Each identified part in an illustration has a reference number. The reference number for a part also appears in the parts list, along with other information about the part.

This catalog uses two special reference number formats, one to indicate parts in a service assembly and another to indicate the quantity of a given part in an illustration.

Service Assembly Reference Numbers

Parts in service assemblies have reference numbers in the form a:b. The a represents the reference number of the entire service assembly and the b represents a sequential number unique to each part within the service assembly.

For example, a wheel assembly might be identified by reference number 6, the tire by 6:1, the valve by 6:2, and the wheel by 6:3. When you order the assembly identified by reference number 6, you receive all parts identified by reference numbers 6:1, 6:2, and 6:3. However, you may also order any part individually. Reference numbers of this type appear in illustration and in parts lists.

Reference Numbers Indicating Quantity

In an illustration, if a reference number indicates more than one part, the reference number has the form nX y. The n represents the quantity of the part, the X is the multiplication symbol, and the y represents the reference number.

For example, in an illustration, the reference number 2X 37 means that two of the parts identified by reference number 37 are indicated.

List of Abbreviations

AR: as required

ASM: assembly

BBC: blade brake control

BHTF: button head thread forming

CARR: carriage

CCW: counter clockwise

CW: clockwise

DEG: degrees

DPA: Dual Point Adjustment

ECM: electronic control module

EXT: external

FH: flat head

GA: gauge

HD: heavy-duty

HF: hex flange

HH: hex head

HHF: hex head flange

HHFTF: hex head flange thread forming

HJ: hex jam

HLH: hex lag head

HOC: height-of-cut

HSBH: hex socket button head

HSFH: hex socket flat head

HSH: hex socket head

HWH: hex washer head

HWTF: hex washer head thread forming

HYD: hydraulic

LH: left hand

LPG: Liquid Propane Gas

NI: nylon insert

NPTF: national pipe thread fine

PFH: phillips flat head

PPH: phillips pan head

PPHTF: phillips pan head thread forming

PRH: phillips round head

PTH: phillips truss head

PTO: power-take-off

RH: right hand

ROPS: roll-over protection system

RRB: rear roller brush

SFH: slotted fillister head

SHH: slotted hex head

SHWH: slotted hex washer head

SPH: slotted pan head

SQH: square head

SRH: slotted round head

STD: standard

TAP: self tapping

TTH: torx truss head

Contents

Frame and Caster Wheel Assembly	4
Roll-Over Protection System Assembly No. 116-0231	6
Caster Wheel and Fork Assembly	7
Hydraulic Pump, Idler and Belt Assembly	8
Pump Idler Assembly No. 116-1255	9
LH Hydro Assembly No. 116-6415	10
RH Hydro Assembly No. 116-6416	11
Rear Wheel and Park Brake Assembly	12
Brake Handle Assembly No. 116-7551	13
LPG Valve, Tank and Hose Assembly	14
LPG Solenoid Regulator Assembly No. 116-5638	15
Seat Mounting Assembly	16
Seat Assembly No. 116-0035	17
Motion Control Assembly	18
Fender, Console and Control Assembly	19
LH Console Assembly No. 115-7401	20
RH Console Assembly No. 115-7400	21
Electrical Assembly	22
Deck Lift Assembly	23
Height-of-Cut Assembly No. 109-7438	25
Engine, Clutch and Muffler Assembly	26
Deck Assembly	27
Deck Decal Assembly No. 112-4195	29
Idler Assembly	30
Spindle Assembly No. 119-8500	31
Rubber Deflector Assembly No. 108-2792	32
Lever Assembly No. 107-1664	33
Attachments and Accessories	34

Frame and Caster Wheel Assembly

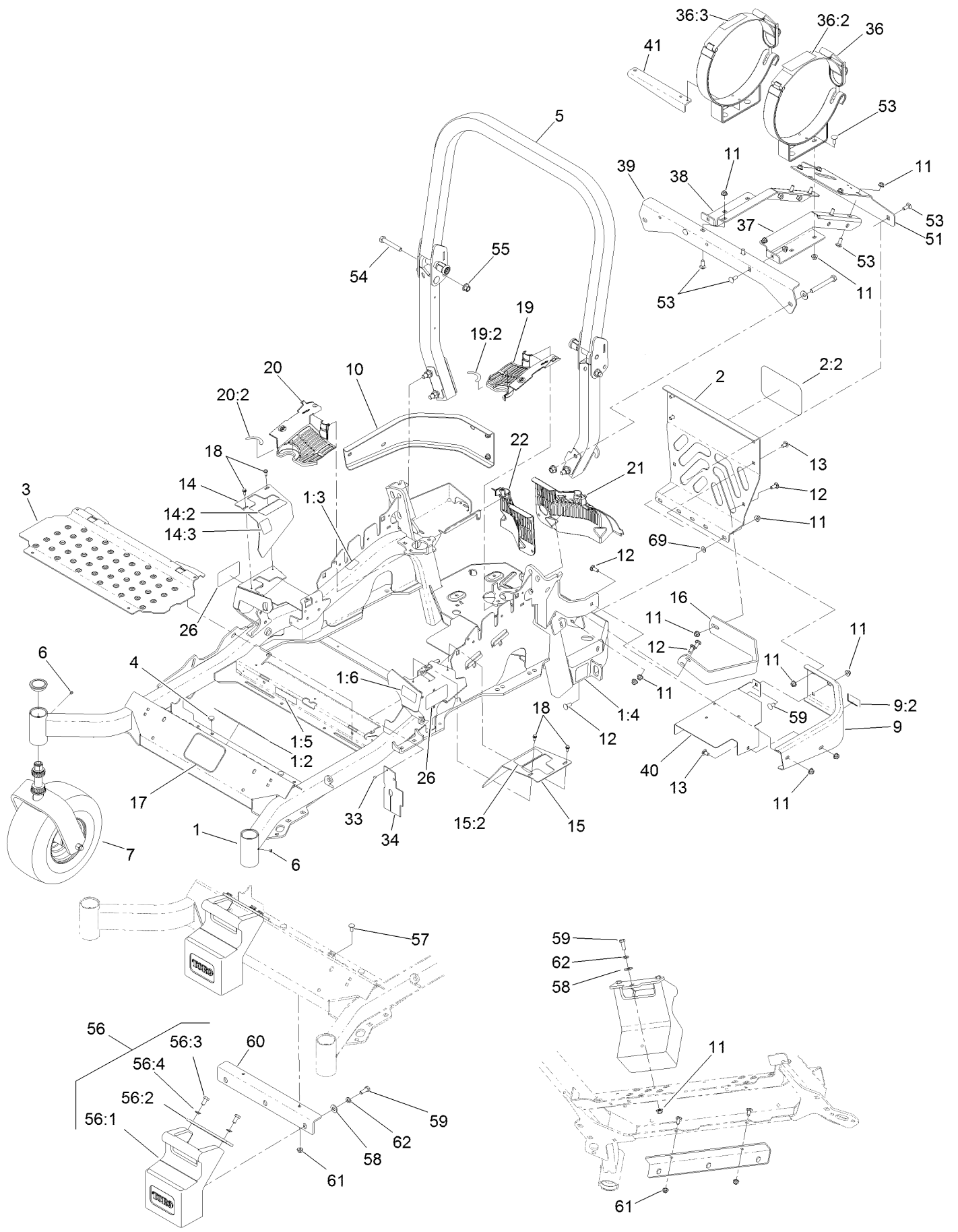

Frame and Caster Wheel Assembly (continued)

<i>Ref.</i>	<i>Part Number</i>	<i>Qty.</i>	<i>Description</i>	<i>Ref.</i>	<i>Part Number</i>	<i>Qty.</i>	<i>Description</i>
1	116-5904	1	Mainframe ASM	20:2	116-0157	1	Decal-Hydro Oil
1:2	103-2076	2	Decal-Caution	21	109-9057	1	Guard-Hydro, Rear LH
1:3	116-3303	1	Decal-Slope	22	109-9058	1	Guard-Hydro, Rear RH
1:4	116-0205	2	Decal-Belt Drive	26	120-5895	2	Decal
1:5	116-4858	1	Decal-Spark Arrester	33	1-803035	2	Rivet-Pop
1:6	116-1654	1	Decal-Fuel Fill	34	116-2362	1	Deflector-Air Flow
2	119-4237	1	Rear Guard ASM	36	116-2817	1	Bracket-Tank
2:2	68-3640	1	Decal	36:2	109-9875	1	Decal-LPG Warning
3	116-0024-01	1	Floorpan	36:3	116-1714	1	Decal-LPG 43.5Lb Tank
4	1-513658	2	Bumper	37	116-2819-03	1	LH LPG Frame ASM
5	116-0231	1	ROPS ASM	38	116-2820-03	1	RH LPG Frame ASM
6	1-811010	2	Plug	39	116-2285-03	1	Support-LPG Frame, Front
7		2	Caster Wheel ASM ●	40	116-4017-03	1	Panel-LPG, Ac
9	116-0180	1	LH Bumper ASM	41	116-2301-03	1	Plate-Index, LPG Tank
9:2	103-2076	1	Decal-Caution	51	116-2553-03	1	Support-Rear Frame, LPG
10	116-0057-03	1	Bumper-RH	53	3231-2	14	Screw-CARR
11	104-8301	26	Nut-Flange, NI	54	325-13	1	Screw-HH
12	3231-22	7	Screw-CARR	55	99-5107	1	Nut-Lock
13	3231-21	5	Screw-CARR	56	120-7885	1	Weight ASM
14	116-5899	1	Cover-Motion Control, RH	56:1	120-7881	1	Weight-43 Lb
14:2	109-7232	1	Decal-Motion Control	56:2	115-3616-01	1	Tab-Support, Weight
14:3	116-5944	1	Decal-Park Brake	56:3	323-4	2	Screw-HH
15	116-0580	1	LH Motion Control Cover ASM	56:4	3253-5	2	Washer-Lock
15:2	109-7232	1	Decal-Motion Control	57	3230-23	2	Screw-CARR
16	116-0043-03	1	Guard-Muffler	58	3256-4	2	Washer-Flat
17	68-3640	1	Decal	59	323-6	3	Screw-HH
18	32144-10	4	Screw-HWH	60	115-3615-01	1	Bracket-Mount, Weight
19	116-0170	1	LH Hydro Guard ASM	61	104-8300	2	Nut-Flange, NI
19:2	116-0157	1	Decal-Hydro Oil	62	3253-5	2	Washer-Lock
20	116-0171	1	RH Hydro Guard ASM	69	107-3154	2	Nut-Push

● Not serviced separately

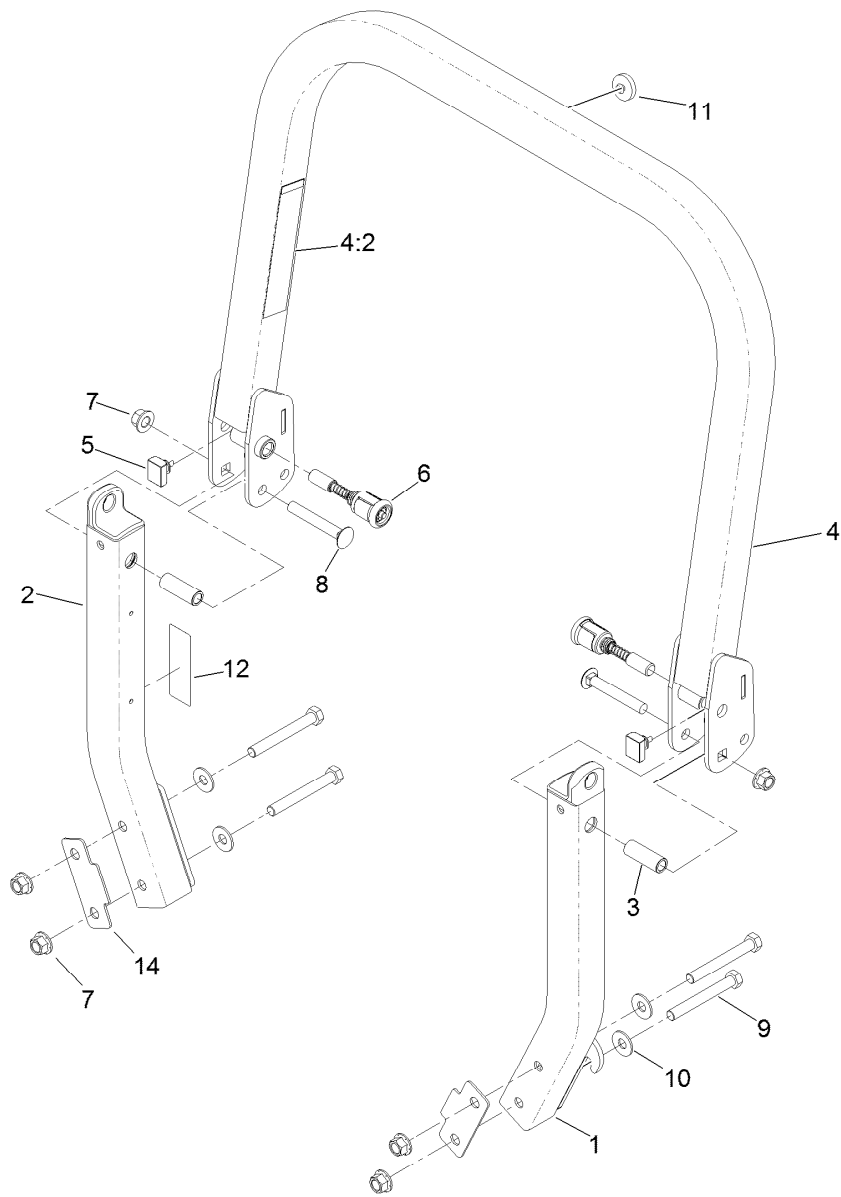

Roll-Over Protection System Assembly No. 116-0231

Ref.	Part Number	Qty.	Description
1		1	LH ROPS Leg ASM ●
2		1	RH ROPS Leg ASM ●
3	109-6653	2	Spacer
4		1	Upper ROPS ASM ●
4:2	107-2102	1	Decal-Warning, Folding ROPS
5	109-5337	2	Bumper-ROPS
6	116-0104	2	Spring Pin ASM
7	99-5107	6	Nut-Lock
8	3233-10	2	Screw-CARR
9	325-17	4	Screw-HH
10	109-9505	4	Washer-Spring
11	109-9233	1	Bumper-Push-In, Rubber
12	116-0090	1	Decal-Caution
14	116-0960	2	Spacer

● Not serviced separately

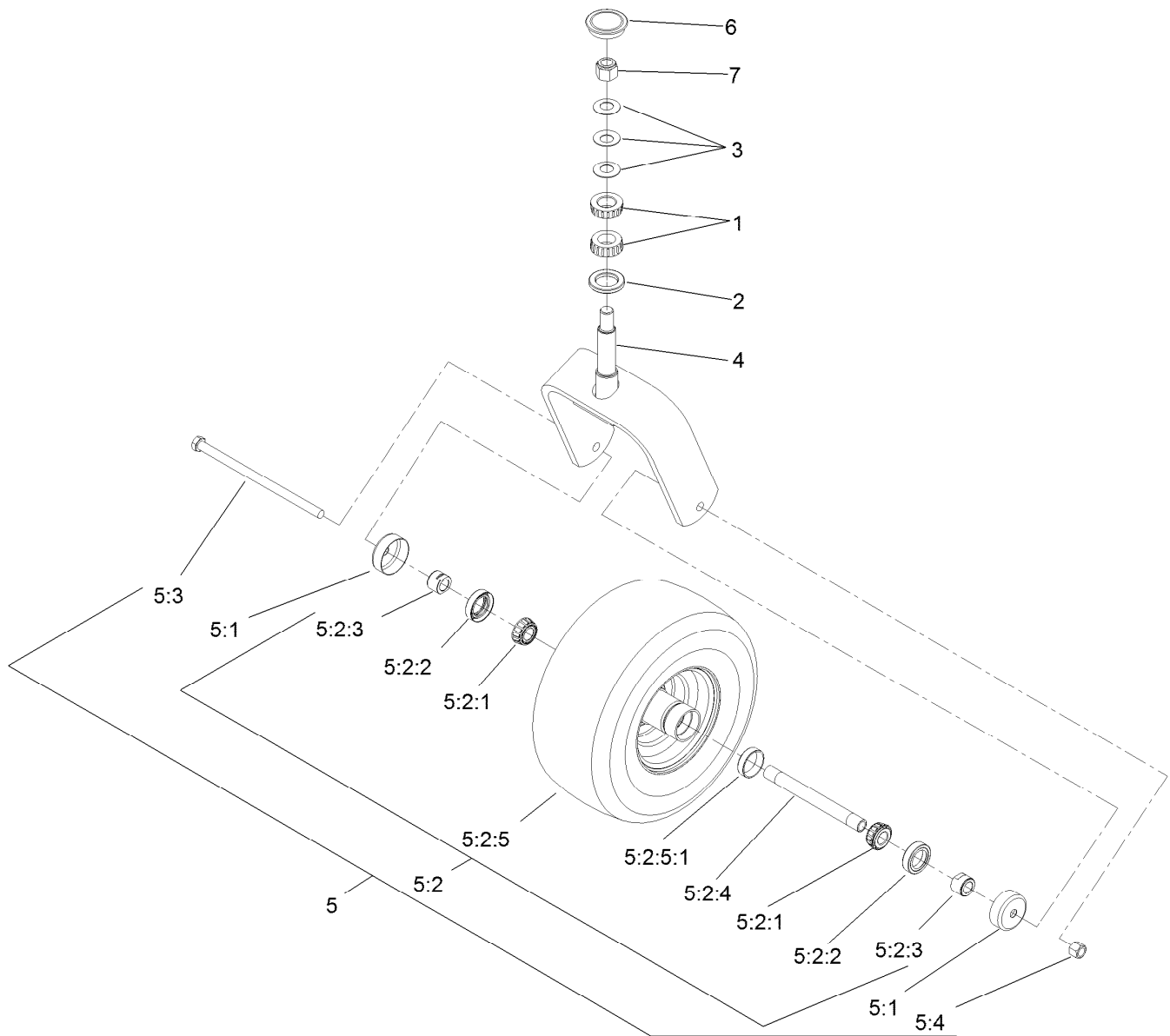

Caster Wheel and Fork Assembly

Ref.	Part Number	Qty.	Description	Ref.	Part Number	Qty.	Description
1	1-543509	2	Bearing-Roller, Tapered	5:2:3	103-3051	2	Spacer-Nut ■
2	1-543511	1	Seal-Grease	5:2:4	103-5156	1	Axle-Caster
3	1-633508	3	Washer-Bellville	5:2:5		1	Wheel And Tire ASM ●
4	103-1474-01	1	Caster-Fork	5:2:5:1	1-633584	1	Bearing-Cup
5	109-9127	1	Wheel And Tire ASM	5:3	325-39	1	Screw-HH
5:1	103-2768	2	Guard-Seal	5:4	3296-23	1	Nut-Lock, NI
5:2		1	Wheel And Tire ASM ●	6	103-4882	1	Cap-Grease
5:2:1	1-633585	2	Bearing-Cone, Taper	7	3296-51	1	Nut-Lock, NI
5:2:2	103-0063	2	Seal-Caster				

● Not serviced separately

■ Use Pro-Lock, Nut Type (P/N 1-840022, .5ml tube) on threads.

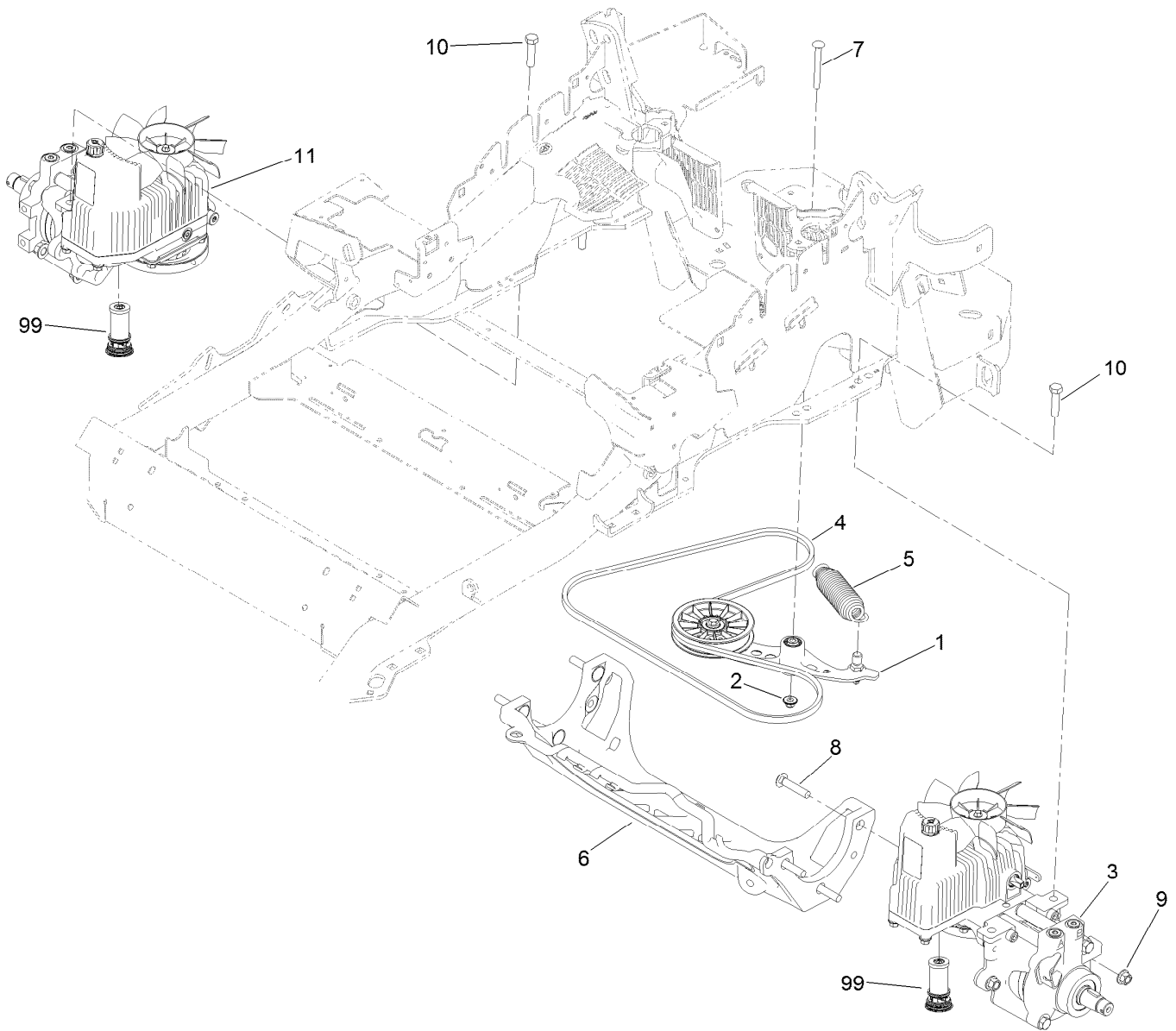

Hydraulic Pump, Idler and Belt Assembly

Ref.	Part Number	Qty.	Description
1	116-1255	1	Pump Idler ASM
2	109-6658	1	Nut-Flange, NI
3	116-6415	1	LH Hydro ASM (16Cc W/Shock)
4	109-3388	1	Belt
5	116-6317	1	Spring-Extension
6	109-9375	1	Cradle-Hydro
7	116-1502	1	Bolt-Shoulder, Carriage
8	3233-34	6	Screw-CARR
9	99-5107	6	Nut-Lock
10	325-8	4	Screw-HH
11	116-6416	1	RH Hydro ASM (16Cc W/Shock)
99	114-4713	1	Hypr-Oil 500 (Quart) ●
99	114-4714	1	Hypr-Oil 500 (Gallon) ●
99	114-4715	1	Hypr-Oil 500-5 (5 Gallon) ●
99	117-0390	1	Filter-Hydro

● Not illustrated

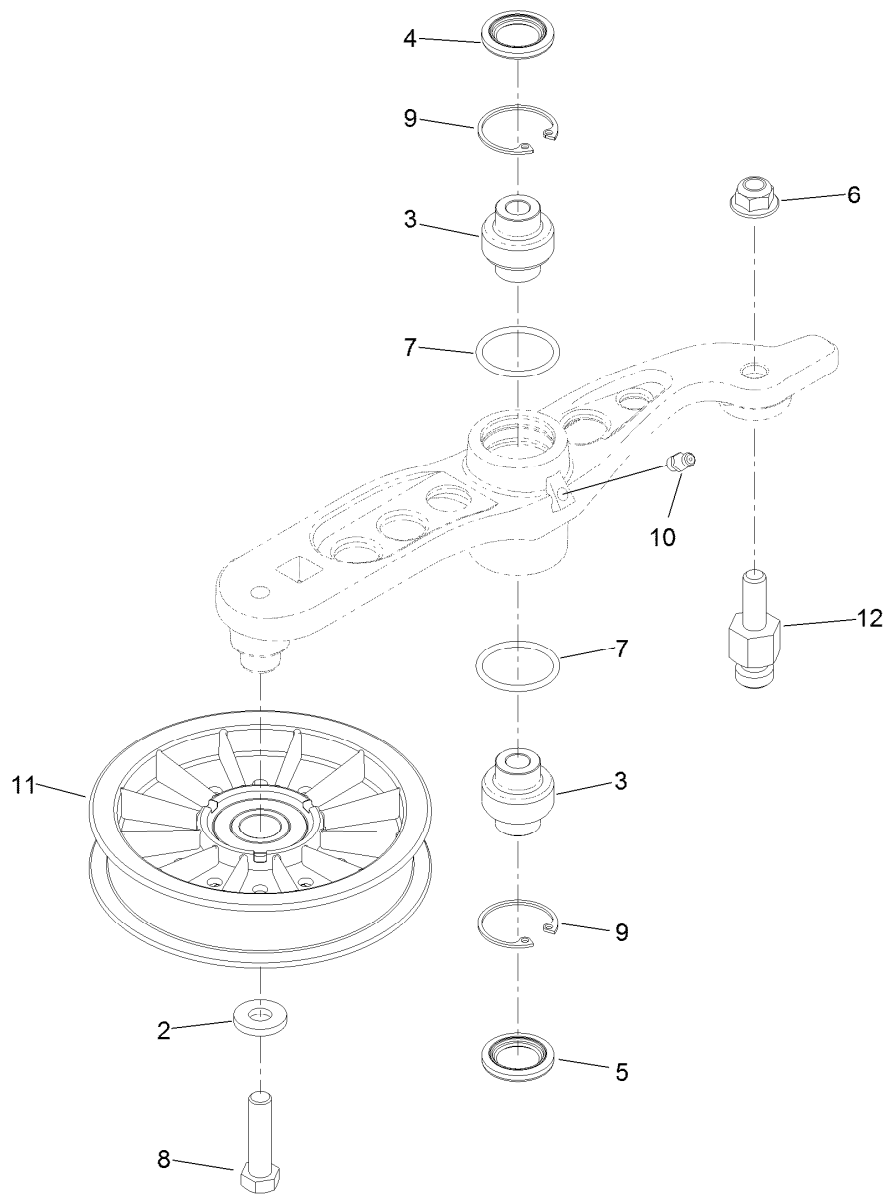

Pump Idler Assembly No. 116-1255

Ref.	Part Number	Qty.	Description
2	43-0940	1	Spacer
3	103-3504	2	Bearing-Spherical
4	103-3505	1	Seal-Double Lip
5	103-3506	1	Seal-Single Lip
6	109-6658	1	Nut-Flange, NI
7	106-7159	2	O-Ring
8	323-8	1	Screw-HH
9	32120-10	2	Ring-Snap
10	302-19	1	Fitting-Grease
11	109-8076	1	Pulley-Idler
12	116-3467	1	Pin-Spring, Anchor

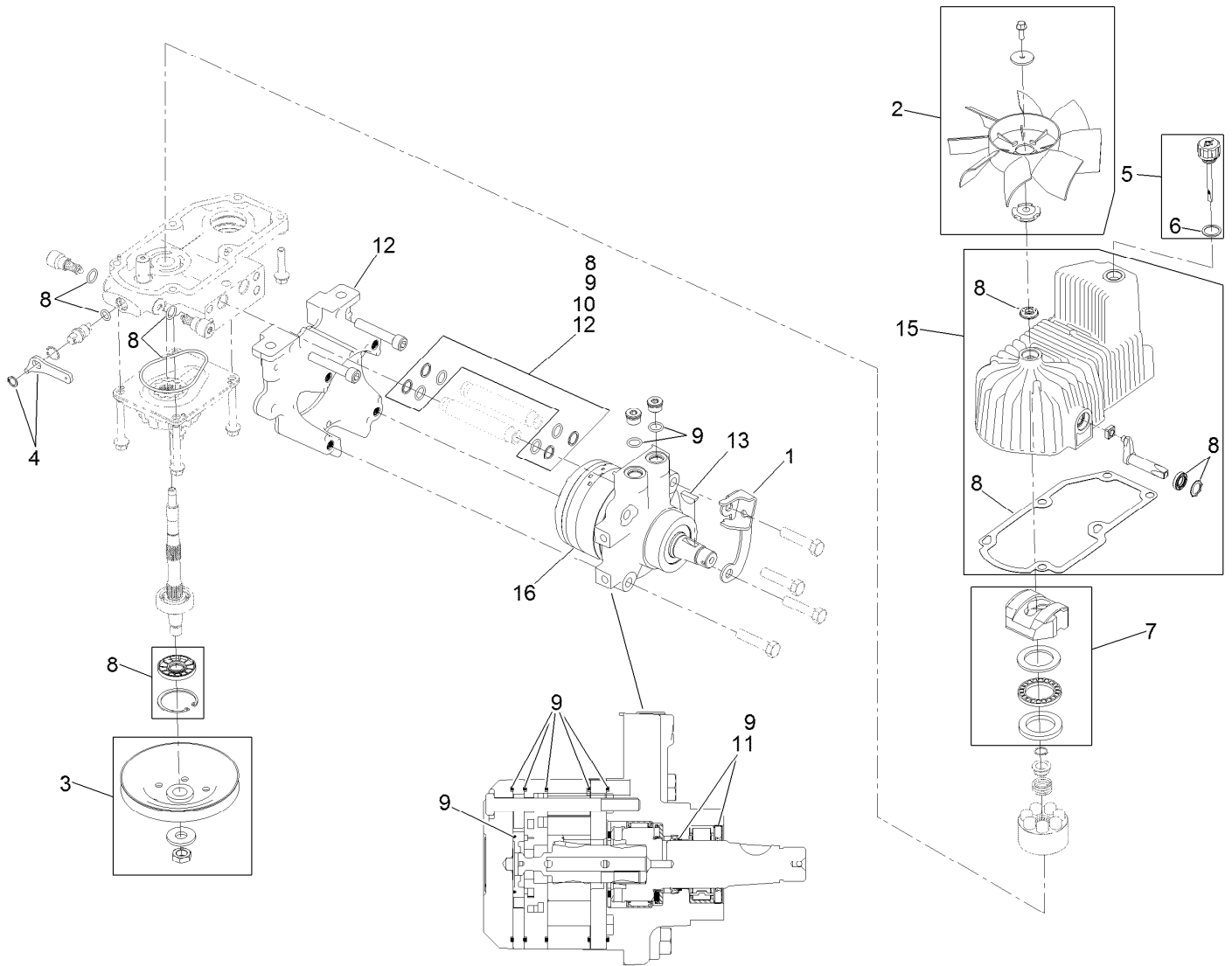

LH Hydro Assembly No. 116-6415

Ref.	Part Number	Qty.	Description	Ref.	Part Number	Qty.	Description
1	116-6859	1	Bracket-Anchor, Cable	9	116-1369	1	Motor Seal Kit
2	116-0233	1	Fan Kit	10	116-1370	1	Tube Seal Kit
3	116-0234	1	Pulley Kit	11	116-1371	1	Output Shaft Seal Kit
4	116-0235	1	Handle-Bypass Valve, Hydro	12	116-5469	1	Nose Cup-Uht
5	116-0236	1	Dipstick-Hydro W/Gasket	13	3257-42	1	Key-Woodruff
6	116-0237	1	Gasket-Dipstick, Hydro	15	116-3287	1	Housing-Hydro, LH
7	116-1367	1	Swash Block Kit	16	116-5467	1	Motor-Hydraulic, LH 280Cc
8	116-1368	1	Pump Seal Kit	99	116-1373	1	Flow Test Kit ●

● Not illustrated

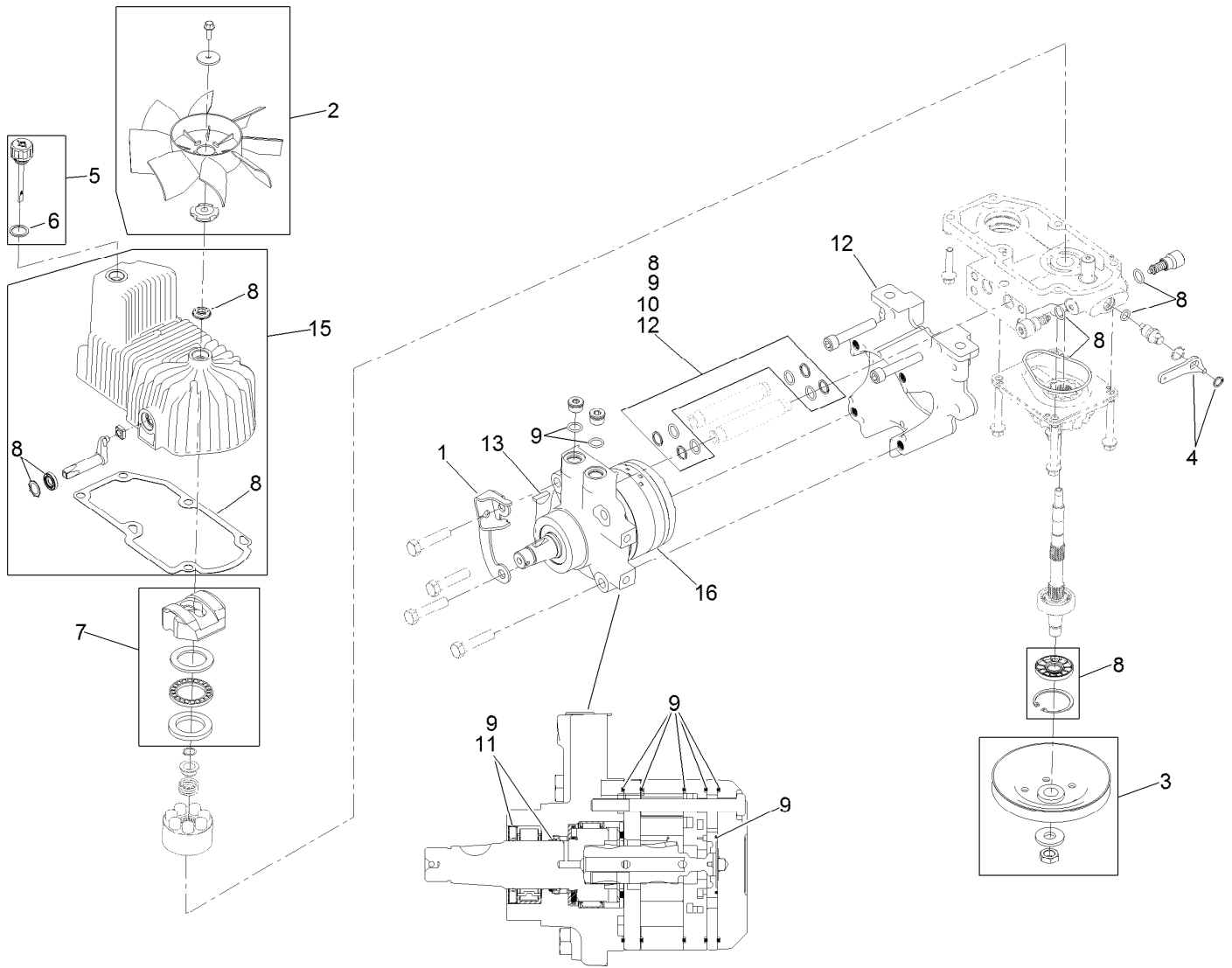

RH Hydro Assembly No. 116-6416

<i>Ref.</i>	<i>Part Number</i>	<i>Qty.</i>	<i>Description</i>	<i>Ref.</i>	<i>Part Number</i>	<i>Qty.</i>	<i>Description</i>
1	116-6859	1	Bracket-Anchor, Cable	9	116-1369	1	Motor Seal Kit
2	116-0233	1	Fan Kit	10	116-1370	1	Tube Seal Kit
3	116-0234	1	Pulley Kit	11	116-1371	1	Output Shaft Seal Kit
4	116-0235	1	Handle-Bypass Valve, Hydro	12	116-5469	1	Nose Cup-Uht
5	116-0236	1	Dipstick-Hydro W/Gasket	13	3257-42	1	Key-Woodruff
6	116-0237	1	Gasket-Dipstick, Hydro	15	116-3288	1	Housing-Hydro, RH
7	116-1367	1	Swash Block Kit	16	116-5468	1	Motor-Hydraulic, RH 280Cc
8	116-1368	1	Pump Seal Kit	99	116-1373	1	Flow Test Kit ●

● Not illustrated

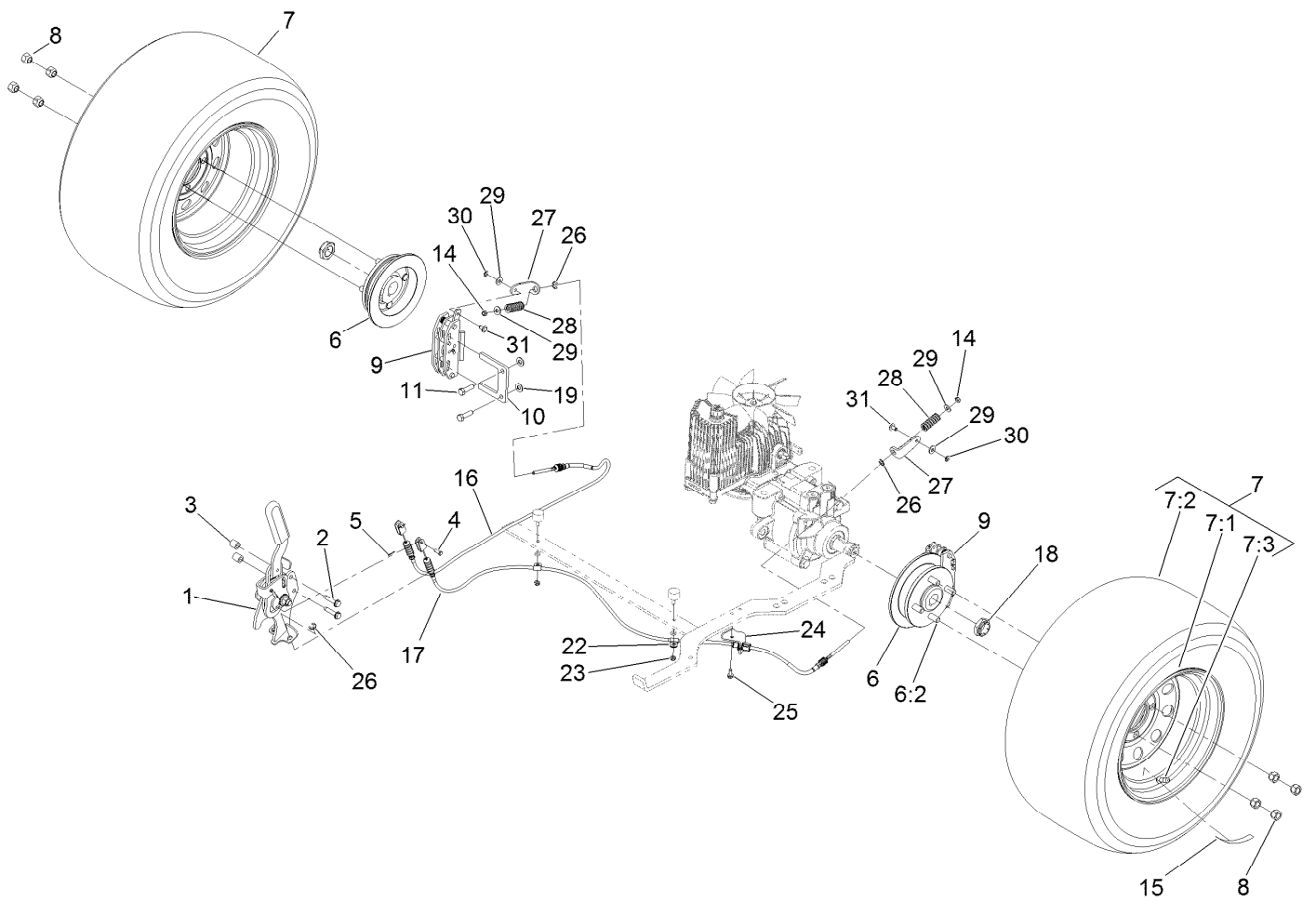

Rear Wheel and Park Brake Assembly

Ref.	Part Number	Qty.	Description	Ref.	Part Number	Qty.	Description
1	116-7551	1	Brake Handle ASM	15	116-2643	2	Decal-Wheel Nut Torque
2	32144-57	2	Screw	16	116-6364	1	Cable-Park Brake, RH
3	82-6840	2	Spacer	17	116-6365	1	Cable-Park Brake, LH
4	60-1730	2	Pin-Clevis	18	116-1399	2	Locknut
5	3272-1	2	Pin-Cotter	19	3256-24	4	Washer-Flat
6	116-1746	2	Wheel Hub ASM	22	88-7970	2	Clip
6:2	116-1696	4	Stud-Wheel	23	3296-56	2	Nut-Lock, NI
7	109-3158	2	Wheel And Tire ASM	24	116-6397	1	Bracket-Cable
7:1	109-3156	1	Rim ASM	25	32144-10	1	Screw-HWH
7:2	103-2744	1	Tire	26	32120-18	4	E-Ring
7:3	232-27	1	Stem-Valve	27	116-6182	2	Bracket-Brake, L
8	242-50	8	Nut-Lug	28	116-6347	2	Spring-Die
9	109-2889	2	Caliper-Brake	29	3256-22	4	Washer-Flat
10	109-0958	2	Plate-Mount, Brake	30	32151-86	2	E-Ring
11	92-5727	4	Screw-Lock, Patch	31	116-6348	2	Pin-Brake
14	3296-13	2	Nut-Lock, NI				

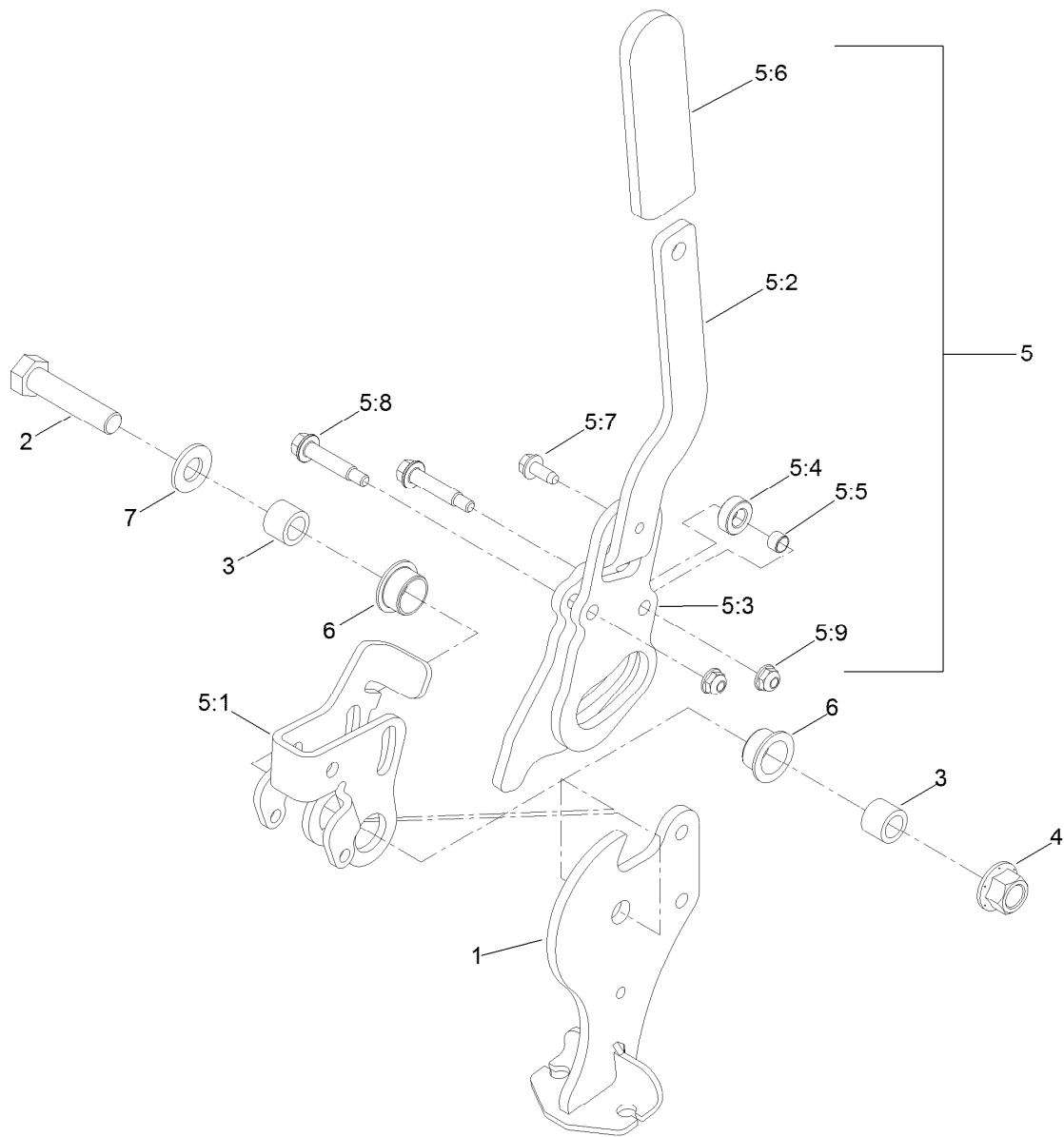

Brake Handle Assembly No. 116-7551

<i>Ref.</i>	<i>Part Number</i>	<i>Qty.</i>	<i>Description</i>	<i>Ref.</i>	<i>Part Number</i>	<i>Qty.</i>	<i>Description</i>
1	116-7263	1	Brake Pivot ASM	5:4	116-6846	1	Roller-Brake
2	325-9	1	Screw-HH	5:5	116-6852	1	Bearing-Sleeve
3	116-5384	2	Spacer	5:6	1-633268	1	Grip-Lever
4	99-5107	1	Nut-Lock	5:7	32144-10	1	Screw-HWH
5	116-6860	1	Handle ASM	5:8	116-6876	2	Screw-Shoulder
5:1	116-6856	1	Bellcrank-Brake	5:9	104-7201	2	Nut-HF
5:2	116-6857	1	Handle-Brake	6	109-8054	2	Bushing-Flange
5:3	116-6858	1	Plate-Handle	7	3256-26	1	Washer-Flat

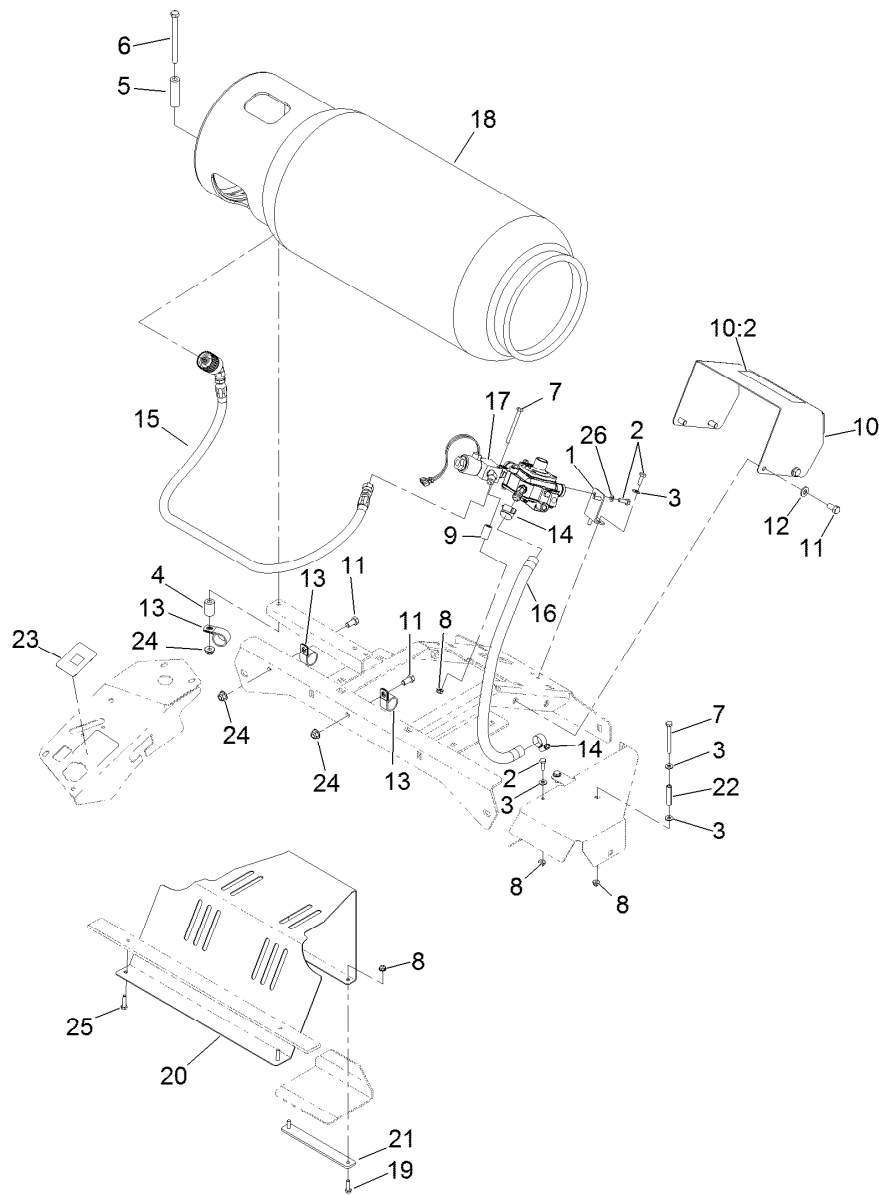

LPG Valve, Tank and Hose Assembly

<i>Ref.</i>	<i>Part Number</i>	<i>Qty.</i>	<i>Description</i>	<i>Ref.</i>	<i>Part Number</i>	<i>Qty.</i>	<i>Description</i>
1	116-2571-03	1	Bracket-Regulator	14	1-543892	2	Clamp-Hose
2	321-4	6	Screw-HH	15	116-2821	1	LPG Fuel Hose ASM
3	3256-22	6	Washer-Flat	16	116-5637	1	Hose-LPG
4	103-1361	1	Spacer-Hydro Control, LH	17	116-5638	1	LPG Regulator Solenoid ASM
5	1-633988	1	Spacer-Anchor, Clutch	18	116-1694	1	Tank-LPG
6	323-23	1	Screw-HH	19	321-5	2	Screw-HH
7	321-14	2	Screw-HH	20	116-3358-03	1	Shield-Fan
8	104-7201	10	Nut-HF	21	116-3359-03	1	Strap
9	94-7564	1	Spacer	22	56-7740	1	Spacer-Split
10	116-2818	1	Cover ASM	23	116-3446	1	Decal-Hour Meter
10:2	109-9906	1	Decal-Tank Replacement	24	104-8301	1	Nut-Flange, NI
11	323-4	6	Screw-HH	25	321-6	2	Screw-HH
12	3256-24	4	Washer-Flat	26	1-303435	2	Washer-Spring
13	1-643312	3	Clip-Loom				

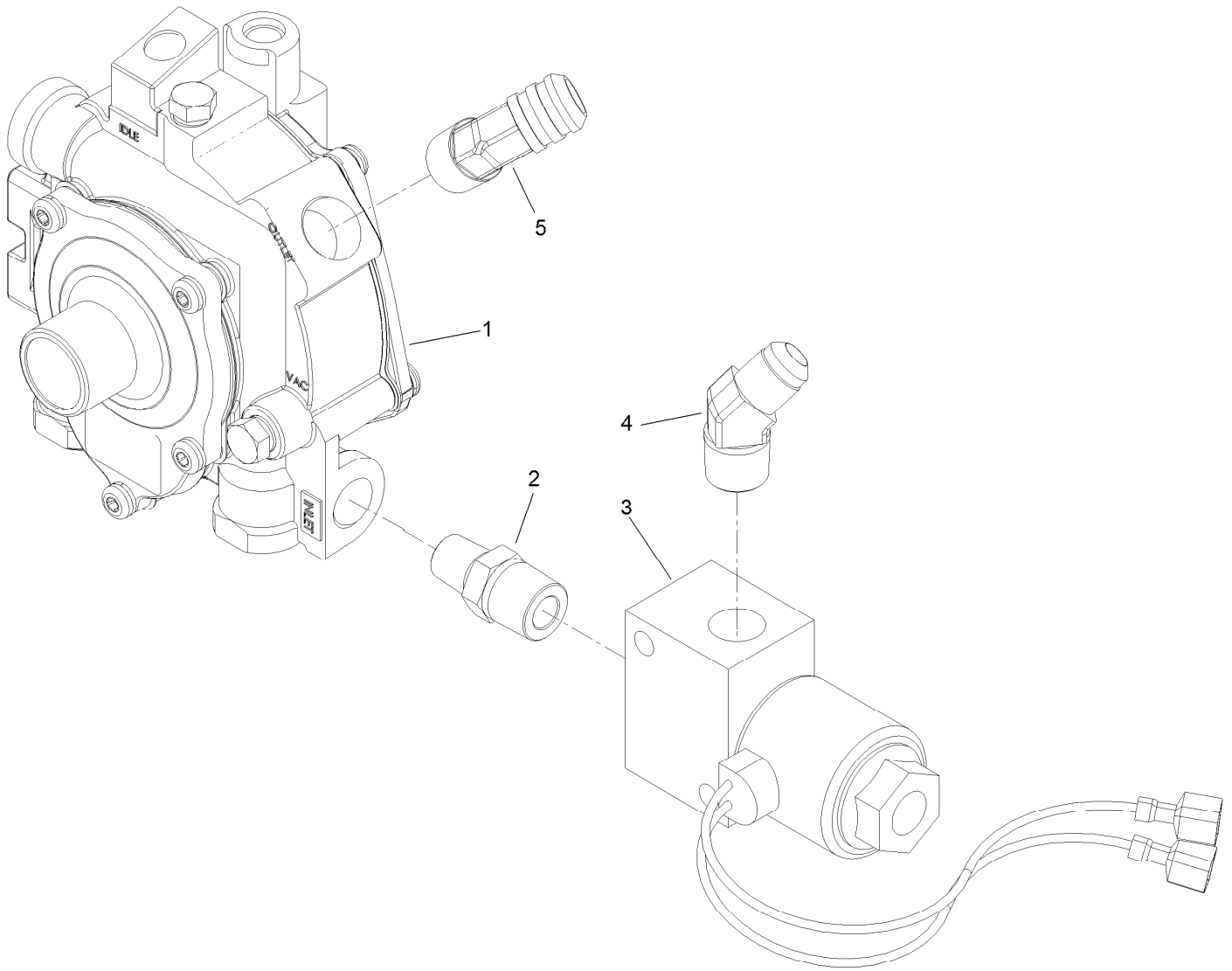

LPG Solenoid Regulator Assembly No. 116-5638

<i>Ref.</i>	<i>Part Number</i>	<i>Qty.</i>	<i>Description</i>
1	116-2567	1	Regulator-LPG, T60
2	93-1347	1	Coupling-Pipe, Male
3	116-2830	1	LPG Solenoid Valve ASM
4	116-2569	1	Elbow
5	116-5636	1	Elbow

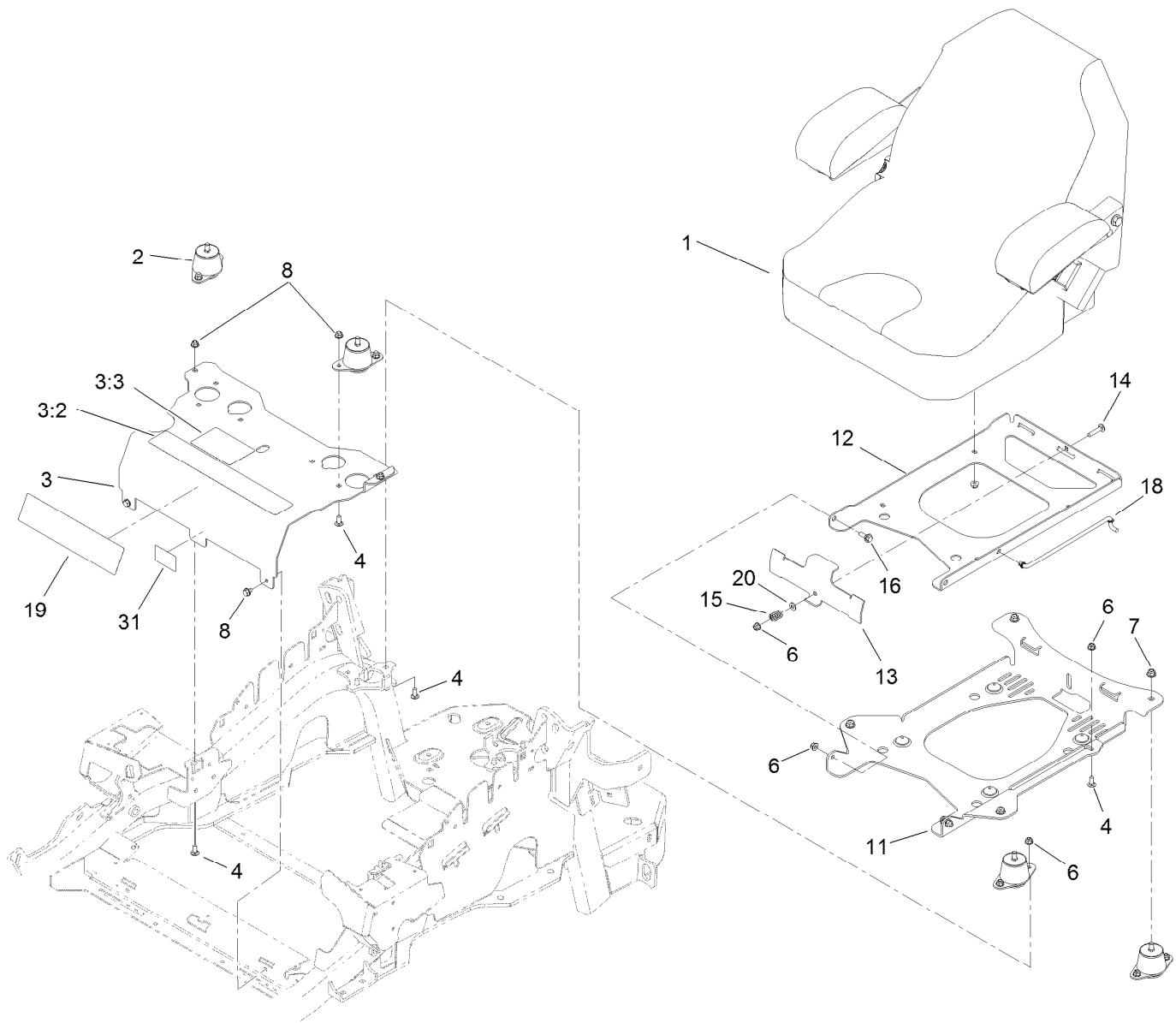

Seat Mounting Assembly

Ref.	Part Number	Qty.	Description
1	116-0035	1	Seat-Standard
2	109-9034	4	Isolator-Seat
3	116-3327	1	Mount-Seat
3:2	109-7069	1	Decal-Console
3:3	116-0211	1	Decal-Service Aid
4	3230-23	11	Screw-CARR
6	104-8300	18	Nut-Flange, NI
7	104-8301	4	Nut-Flange, NI
8	9266934	2	Screw
11	116-3860-03	1	Plate-Tilt, Seat Support

Ref.	Part Number	Qty.	Description
12	116-3859-03	1	Plate-Seat, Frame
13	109-9881-03	1	Plate-Latch, Seat
14	3230-4	1	Screw-CARR
15	107-3017	1	Spring-Compression
16	116-1297	2	Screw-Shoulder
18	116-0070	1	Rod-Prop
19	120-5893	1	Decal
20	3256-23	1	Washer-Flat
31	121-7561	1	Decal-Propane

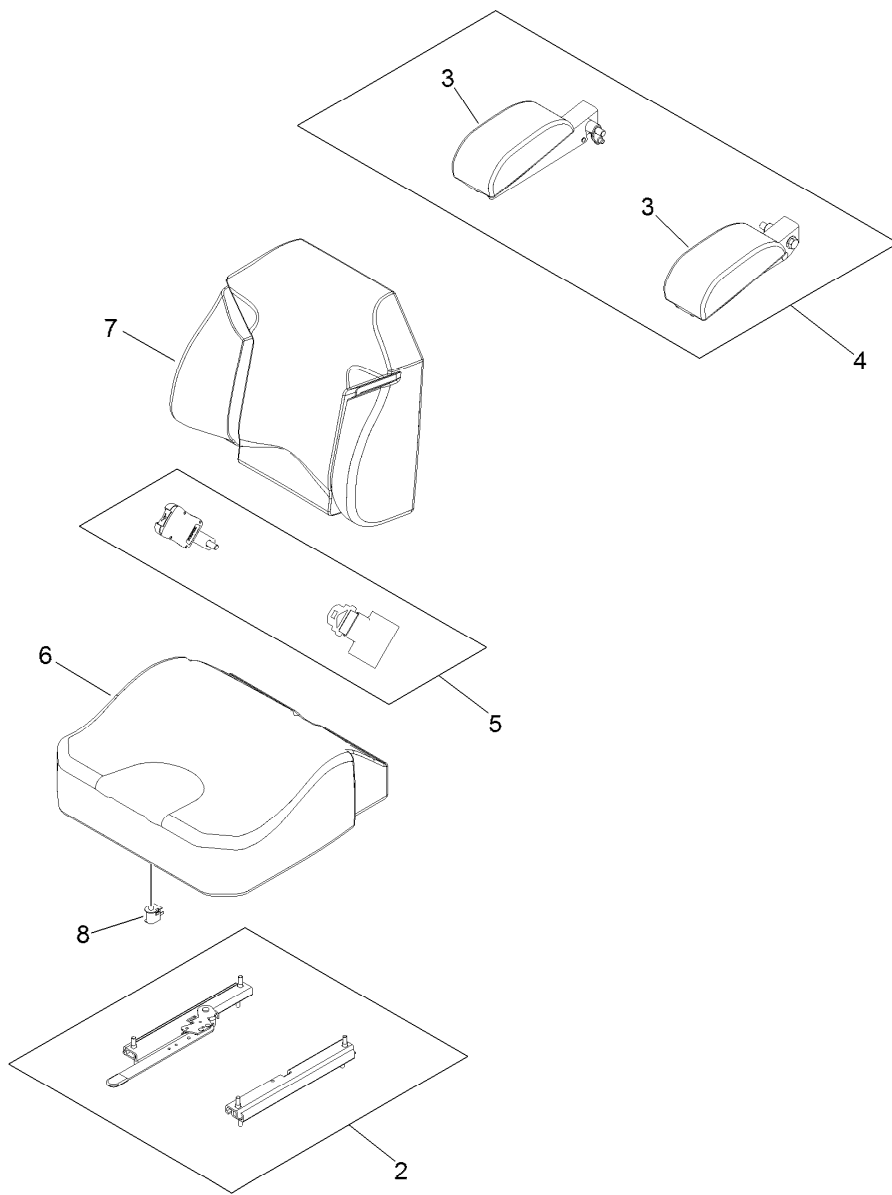

Seat Assembly No. 116-0035

<i>Ref.</i>	<i>Part Number</i>	<i>Qty.</i>	<i>Description</i>
2	109-9801	1	Seat Track Set
3	109-9802	1	Arm Rest Pad Set
4	109-9803	1	Arm Rest Set
5	109-9805	1	Seat Belt Kit
6	109-9806	1	Cover-Cushion
7	109-9808	1	Cover-Back
8	82-2190	1	Switch-Bail

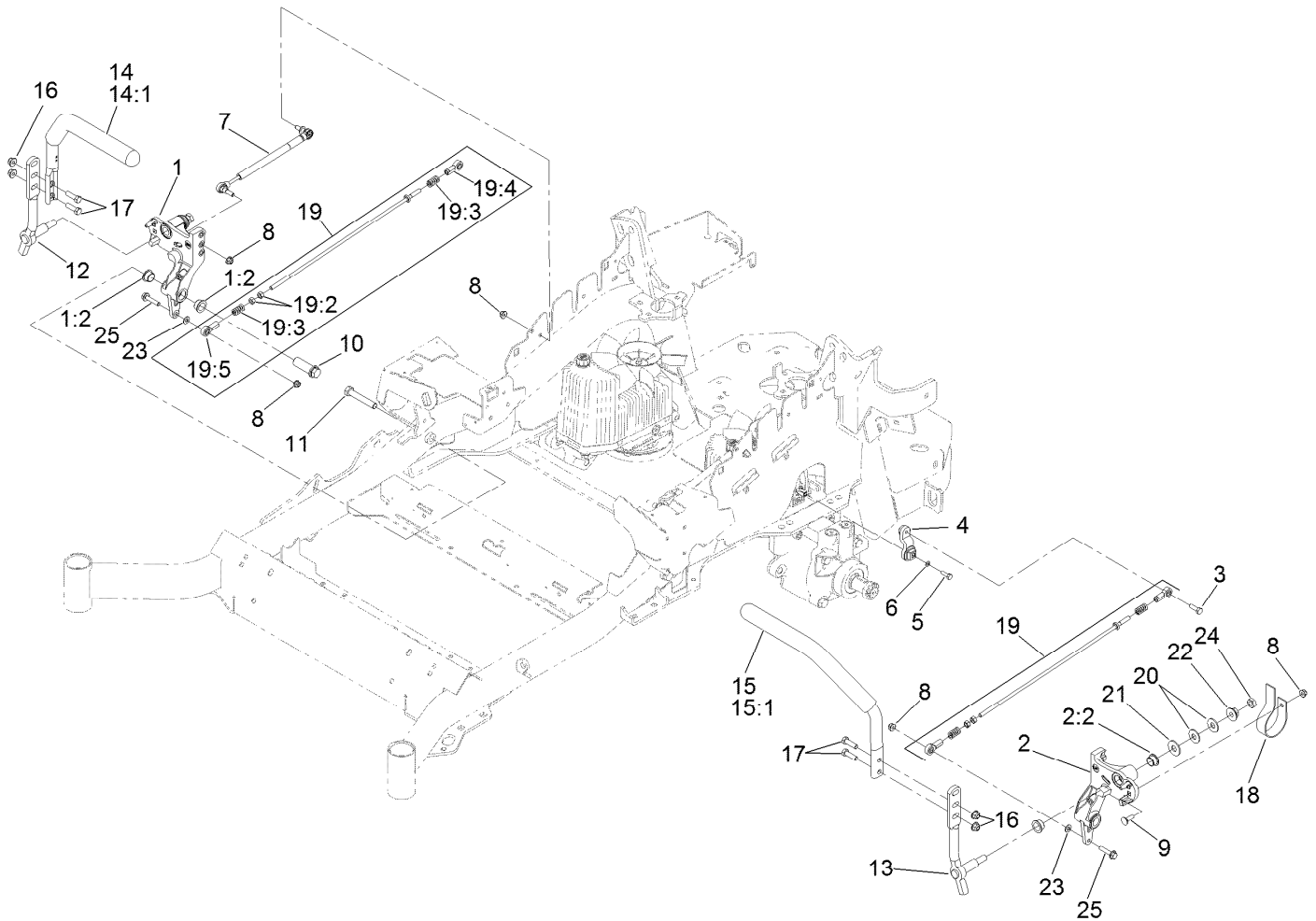

Motion Control Assembly

Ref.	Part Number	Qty.	Description	Ref.	Part Number	Qty.	Description
1	116-0880	1	RH Motion Control And Bushing ASM	14	109-6589	1	RH Steering Handle ASM
1:2	109-8054	4	Bushing-Flange	14:1	109-5668	1	Grip-Control, Lever
2	116-0881	1	LH Motion Control And Bushing ASM	15	109-6590	1	LH Steering Handle ASM
2:2	109-8054	4	Bushing-Flange	15:1	109-5668	1	Grip-Control, Lever
3	116-0648	2	Screw-HH, Thread Locking ●	16	104-8301	4	Nut-Flange, NI
4	109-4581	2	Arm-Control, Pump	17	323-7	4	Screw-HH
5	9080046	2	Screw-HH ●	18	109-5575	2	Spring-Leaf
6	1-303435	2	Washer-Spring	19	109-8106	2	Front Pump Linkage ASM
7	116-0027	2	Damper-Control, Motion	19:2	3219-2	2	Nut-Hex
8	104-8300	8	Nut-Flange, NI	19:3	1-323245	2	Spring-Compression
9	3230-2	2	Bolt-CARR	19:4	1-633152	1	Balljoint-LH
10	109-5891	2	Hub-Threaded	19:5	1-543017	1	Balljoint-RH
11	325-12	2	Screw-HH	20	109-9505	4	Washer-Spring
12	116-0039	1	Lever-Control Motion, RH	21	3256-6	2	Washer-Flat
13	116-0040	1	Lever-Control Motion, LH	22	32128-56	2	Nut-HF
				23	3256-23	2	Washer-Flat
				24	3218-5	2	Nut-Jam
				25	115-1794	2	Screw-HHF

● Use Pro-Lock, Nut Type (P/N 1-840022, .5ml tube) on threads.

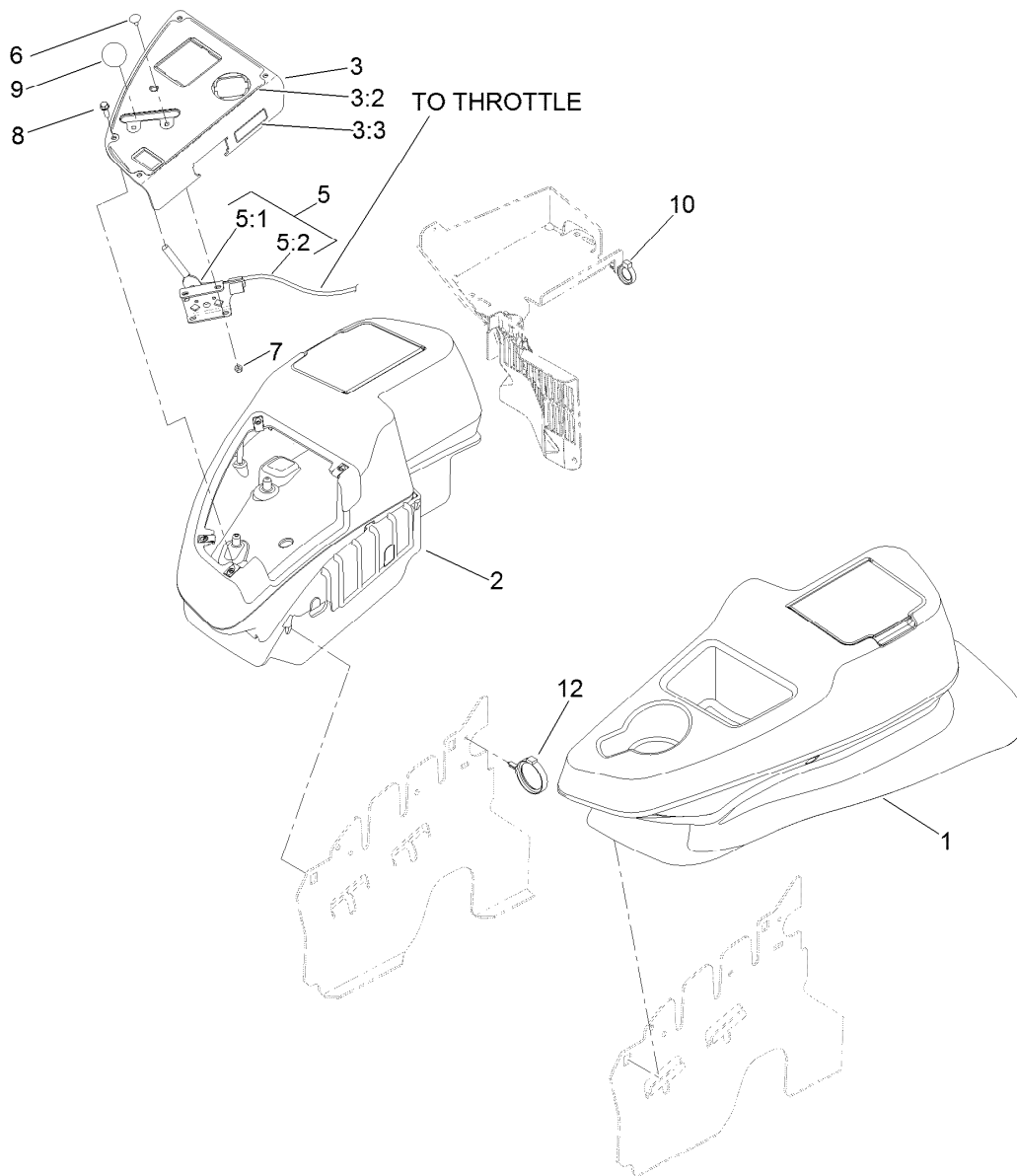

Fender, Console and Control Assembly

<i>Ref.</i>	<i>Part Number</i>	<i>Qty.</i>	<i>Description</i>
1	115-7401	1	LH Wide Fender/Console ASM
2	115-7400	1	RH Wide Fender/Console ASM
3	119-4234	1	Control Panel ASM
3:2	121-7550	1	Decal-Control Panel
3:3	114-4466	1	Decal-Fuses
5	110-5727	1	Throttle Control ASM
5:1	112-2334	1	Lever-Throttle
5:2	110-5728	1	Cable-Throttle
6	1-807513	2	Bolt-CARR
7	3296-2	2	Nut-Lock, NI
8	32105-15	4	Screw
9	1-603175	1	Knob-Ball
10	105-1853	1	Clamp-Hose
12	117-7817	1	Clamp-Harness

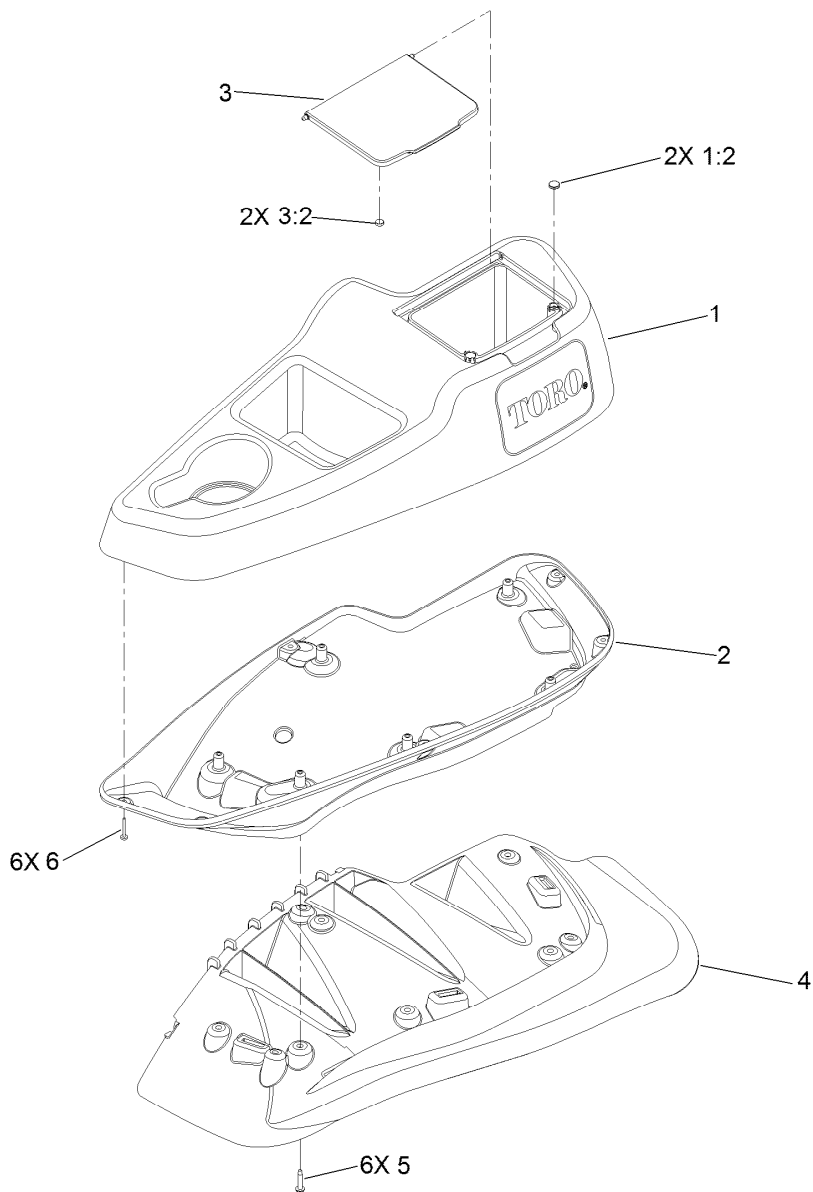

LH Console Assembly No. 115-7401

Ref.	Part Number	Qty.	Description
1	114-1539	1	LH Wide Console Top ASM
1:2	117-0883	2	Puck
2	115-3641	1	Console-Lower, LH Wide
3	114-1537	1	Wide Lid ASM
3:2	114-5896	2	Magnet
4	109-9085	1	Fender-Wide, LH
5	32144-89	6	Screw-Thread Forming
6	117-0347	6	Screw-Fillister Head

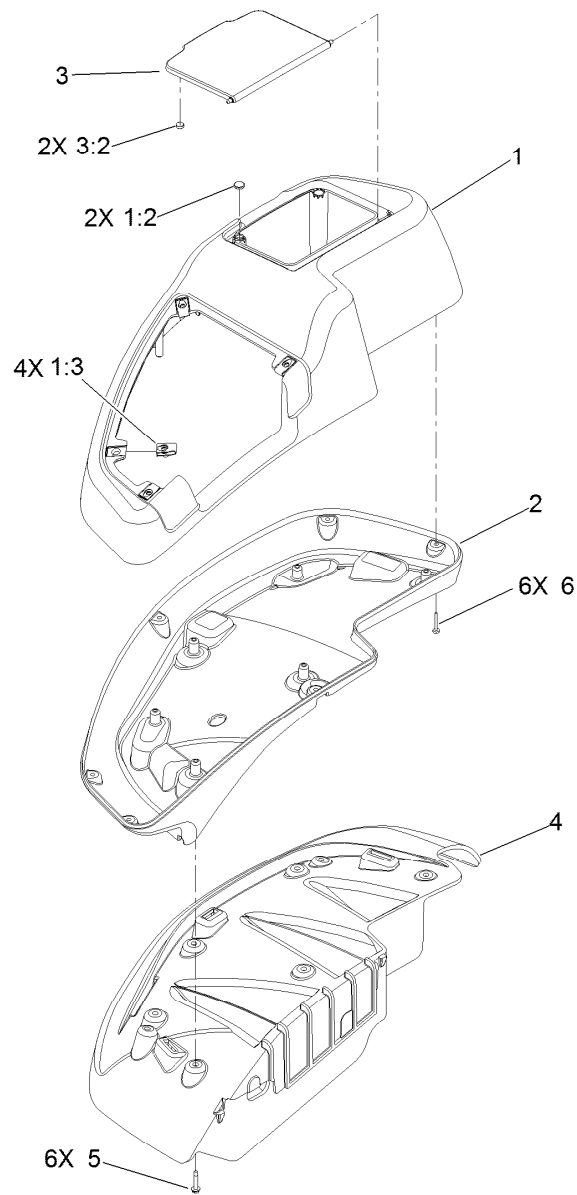

RH Console Assembly No. 115-7400

<i>Ref.</i>	<i>Part Number</i>	<i>Qty.</i>	<i>Description</i>
1	114-1538	1	RH Wide Top Console ASM
1:2	117-0883	2	Puck
1:3	107069	4	Clip
2	115-3643	1	Console-Lower, RH Wide
3	114-1537	1	Wide Lid ASM
3:2	114-5896	2	Magnet
4	109-9083	1	Fender-Wide, RH
5	32144-89	6	Screw-Thread Forming
6	117-0347	6	Screw-Fillister Head

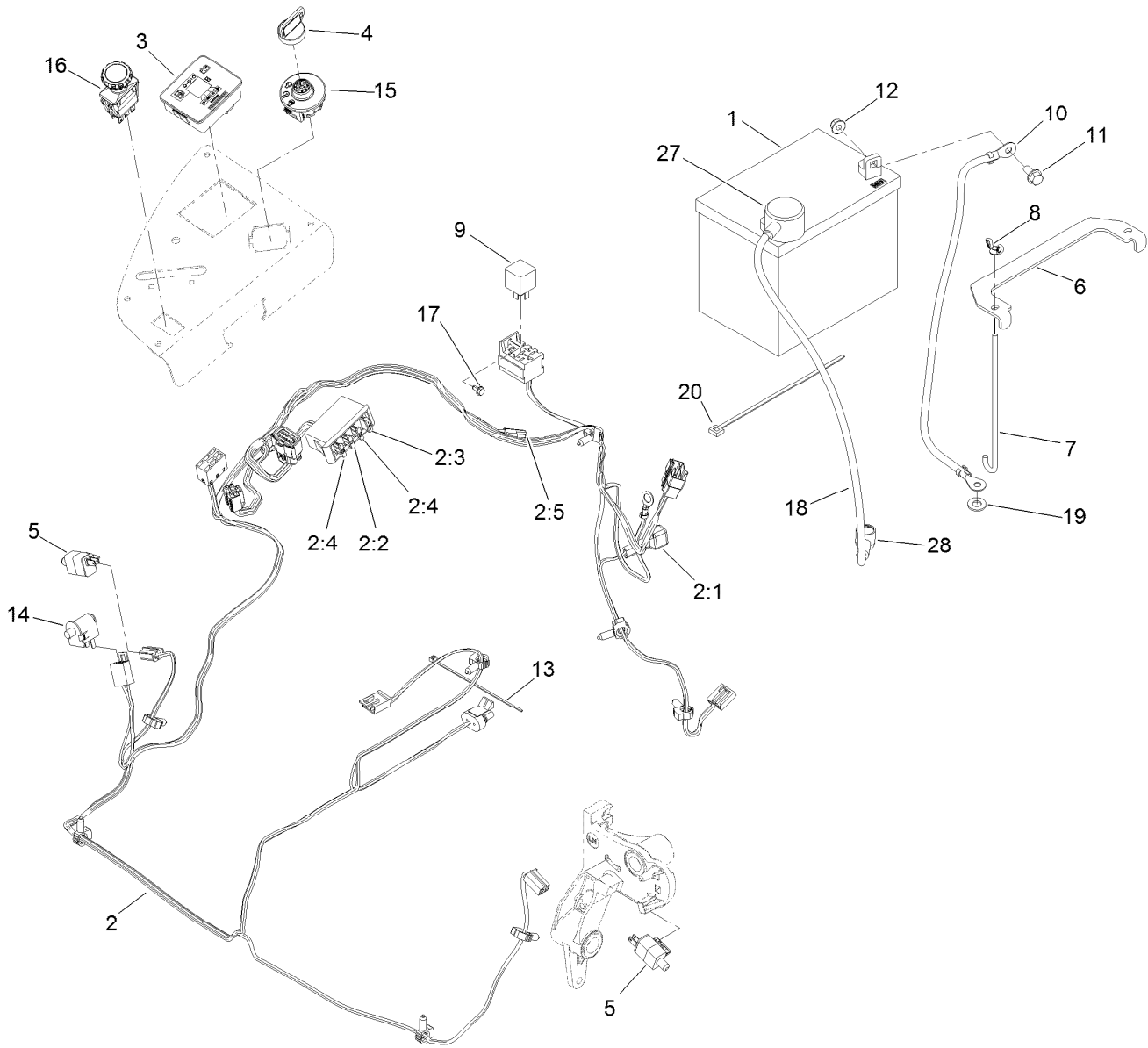

Electrical Assembly

Ref.	Part Number	Qty.	Description	Ref.	Part Number	Qty.	Description
1	104-8162	1	Battery	10	114-1218	1	Cable-Battery, Negative
2	116-6009	1	Harness-Wire, Main ●	11	3234-5	2	Screw-HHF
2:1	103-3895	1	Diode-Tvs	12	104-8300	2	Nut-Flange, NI
2:2	218-578	1	Fuse-Blade, 10 Amp	13	1-303287	3	Tie-Cable
2:3	109355	1	Fuse-Blade, 15 Amp	14	82-2190	1	Switch-Bail
2:4	109102	2	Fuse-Blade, 25 Amp	15	117-2221	1	Switch-Ignition
2:5	116-0053	1	Cap-Plug	16	116-0124	1	Switch-PTO, 10A
3	117-3882	1	Fuel/Hour Meter ASM	17	104-2065	1	Screw-HWH
4	63-8360	1	Key-Ignition	18	115-3864	1	Cable-Battery, Positive
5	110-6765	2	Switch-Single Pole No	19	3256-24	1	Washer-Flat
6	116-0042-03	1	Strap-Tie Down, Battery	20	1-303335	1	Tie-Plastic
7	1-633651	2	Bolt-Holddown	27	109-2407	1	Insulator-Battery
8	1-543792	2	Wingnut	28	1-543393	1	Insulator-Solenoid
9	1-643275	1	Relay				

● Use dielectric grease on all unsealed connectors and terminals only. Do not apply in sealed connectors.

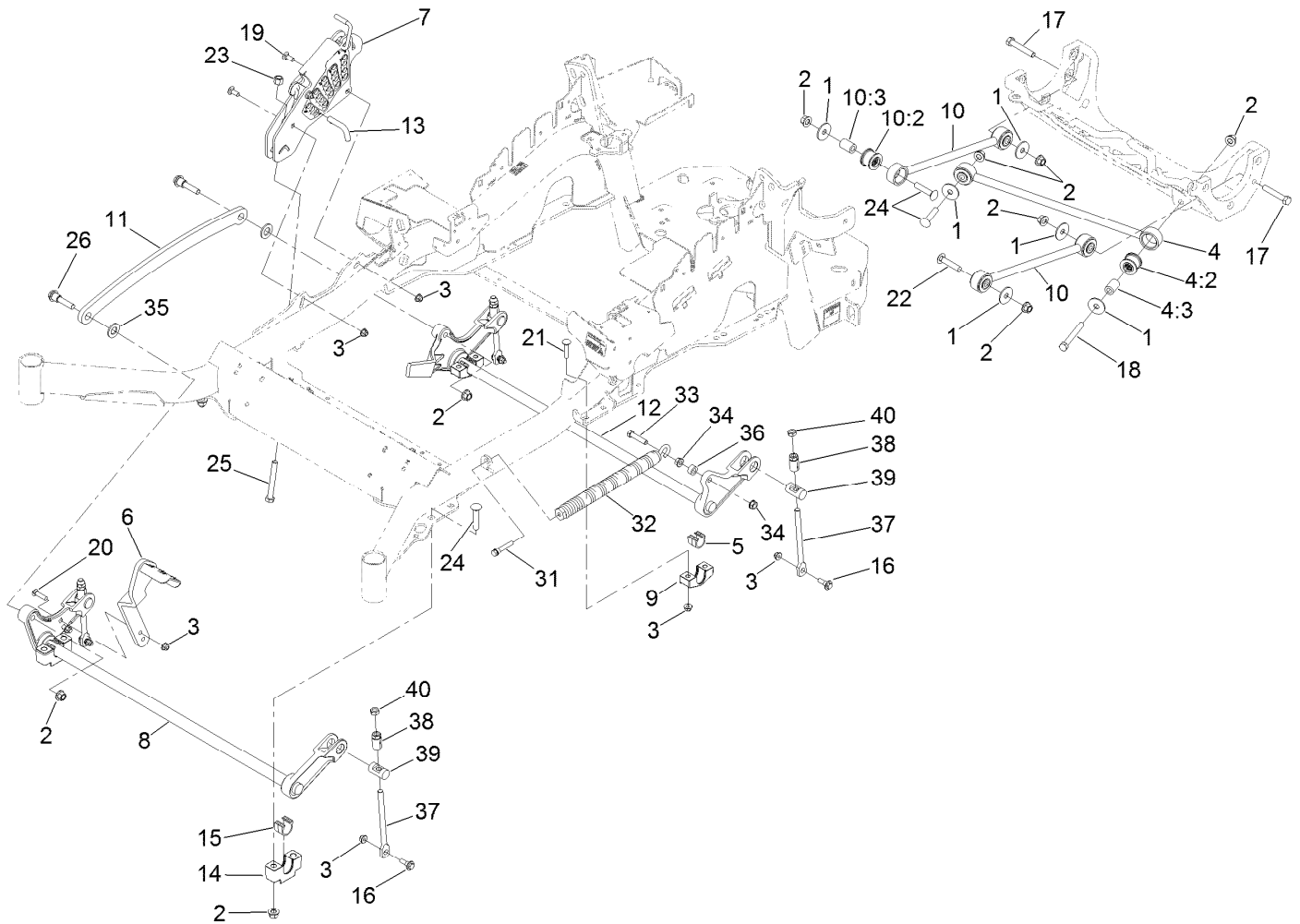

Deck Lift Assembly

Ref.	Part Number	Qty.	Description	Ref.	Part Number	Qty.	Description
1	86-1990	6	Washer	14	109-9409	2	Support-Cross Shaft, Front Bearing
2	99-5107	12	Nut-Lock	15	109-9410	2	Bearing-Cross Shaft, Front
3	104-8301	12	Nut-Flange, NI	16	109-9840	4	Screw-Shoulder, HHF
4	109-5013	1	Panhard Rod ASM	17	325-12	2	Screw-HH
4:2	109-5009	2	Bushing-Suspension, Rubber	18	325-17	1	Screw-HH
4:3	109-5010	2	Spacer	19	3231-2	2	Screw-CARR
5	109-7173	2	Bearing-Cross Shaft, Rear	20	3231-4	2	Screw-CARR
6	116-1919-01	1	Lever-Foot	21	3231-5	4	Screw-CARR
7	109-7438	1	HOC ASM	22	3233-34	3	Screw-CARR
8	116-1771-03	1	Deck Lift-Front	23	3296-23	1	Nut-Lock, NI
9	116-0818-03	2	Support-Cross Shaft, Rear Bearing	24	116-1700	4	Bolt-CARR
10	109-7952	2	Deck Strut ASM	25	116-0559	1	Bolt-TAP
10:2	109-5009	2	Bushing-Suspension, Rubber	26	116-2022	2	Screw-HHF, Shoulder
10:3	109-5010	2	Spacer	31	92-7674	1	Bolt-Shoulder
11	116-0797-03	1	Link-Lift, Deck	32	116-0000	1	Extension Spring ASM
12	116-2645-03	1	Lift-Deck, Rear	33	109-9065	1	Screw-HH
13	116-5584	1	Pin-HOC	34	32128-37	2	Nut-HF
				35	3256-28	2	Washer-Flat
				36	116-2695	1	Spacer
				37	109-8007	4	Link-Adjuster, Deck Lift

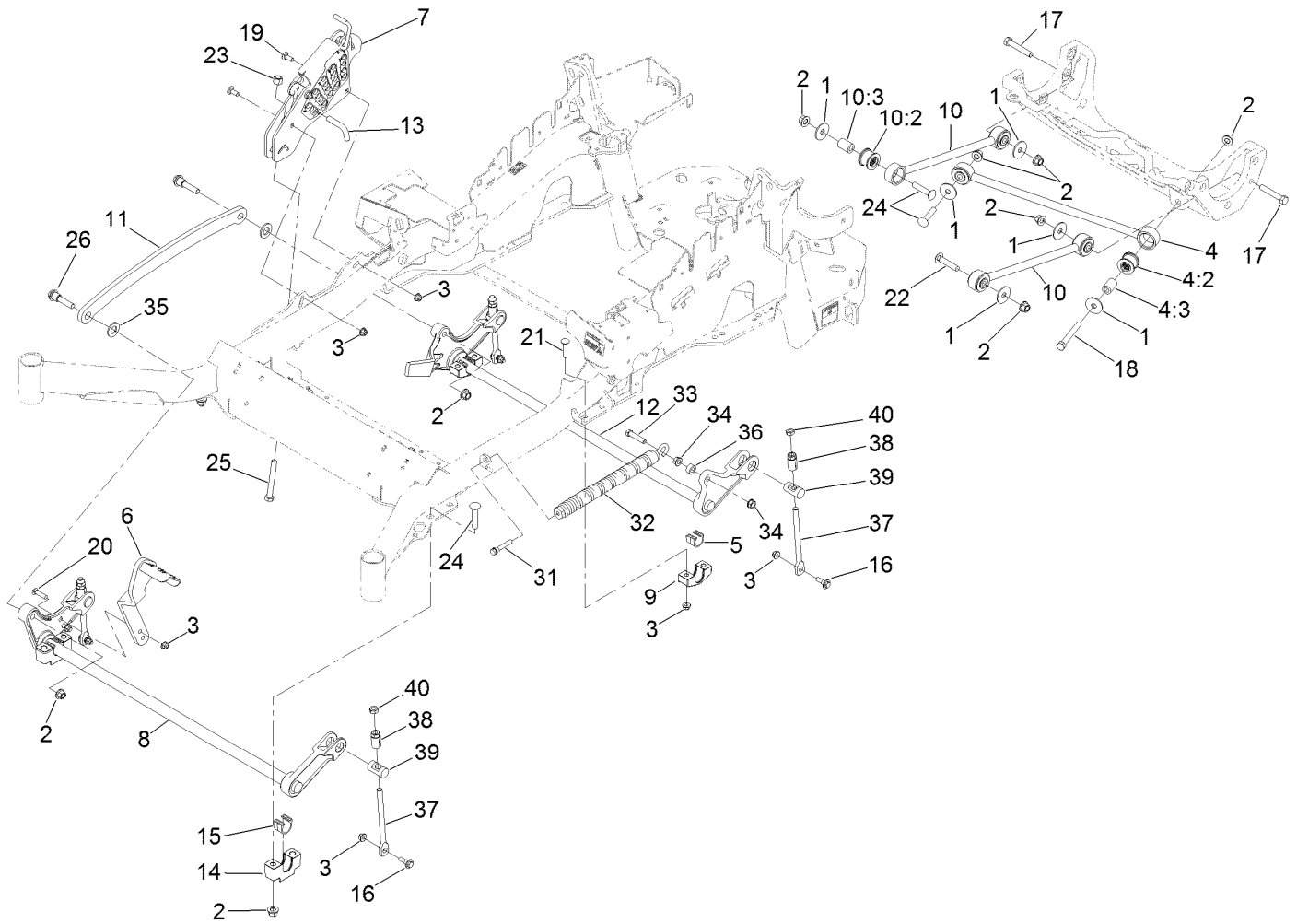

Deck Lift Assembly (continued)

<i>Ref.</i>	<i>Part Number</i>	<i>Qty.</i>	<i>Description</i>	<i>Ref.</i>	<i>Part Number</i>	<i>Qty.</i>	<i>Description</i>
38	109-7840	4	Adjuster-Lift, Deck	39	109-8353	4	Trunnion
				40	3218-5	4	Nut-Jam

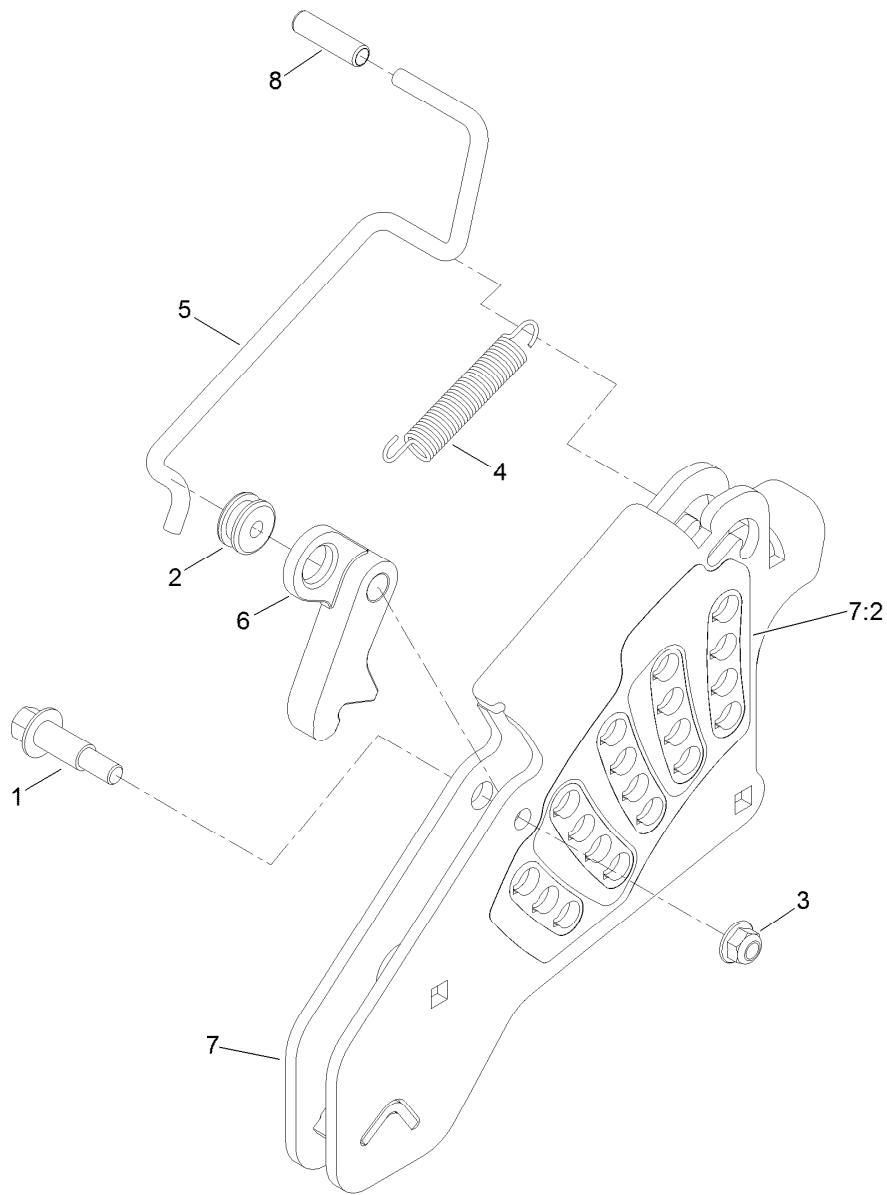

Height-of-Cut Assembly No. 109-7438

<i>Ref.</i>	<i>Part Number</i>	<i>Qty.</i>	<i>Description</i>
1	62-1330	1	Bolt-Shoulder
2	109-7130	1	Grommet
3	104-8301	1	Nut-Flange, NI
4	109-7124	1	Spring-Extension
5	109-7128	1	Rod-Lock, Transport
6	116-0118	1	Pawl-Transport, HOC
7	109-7335	1	HOC Plate ASM
7:2	116-0752	1	Decal-HOC
8	109-8250	1	Grip-Lever

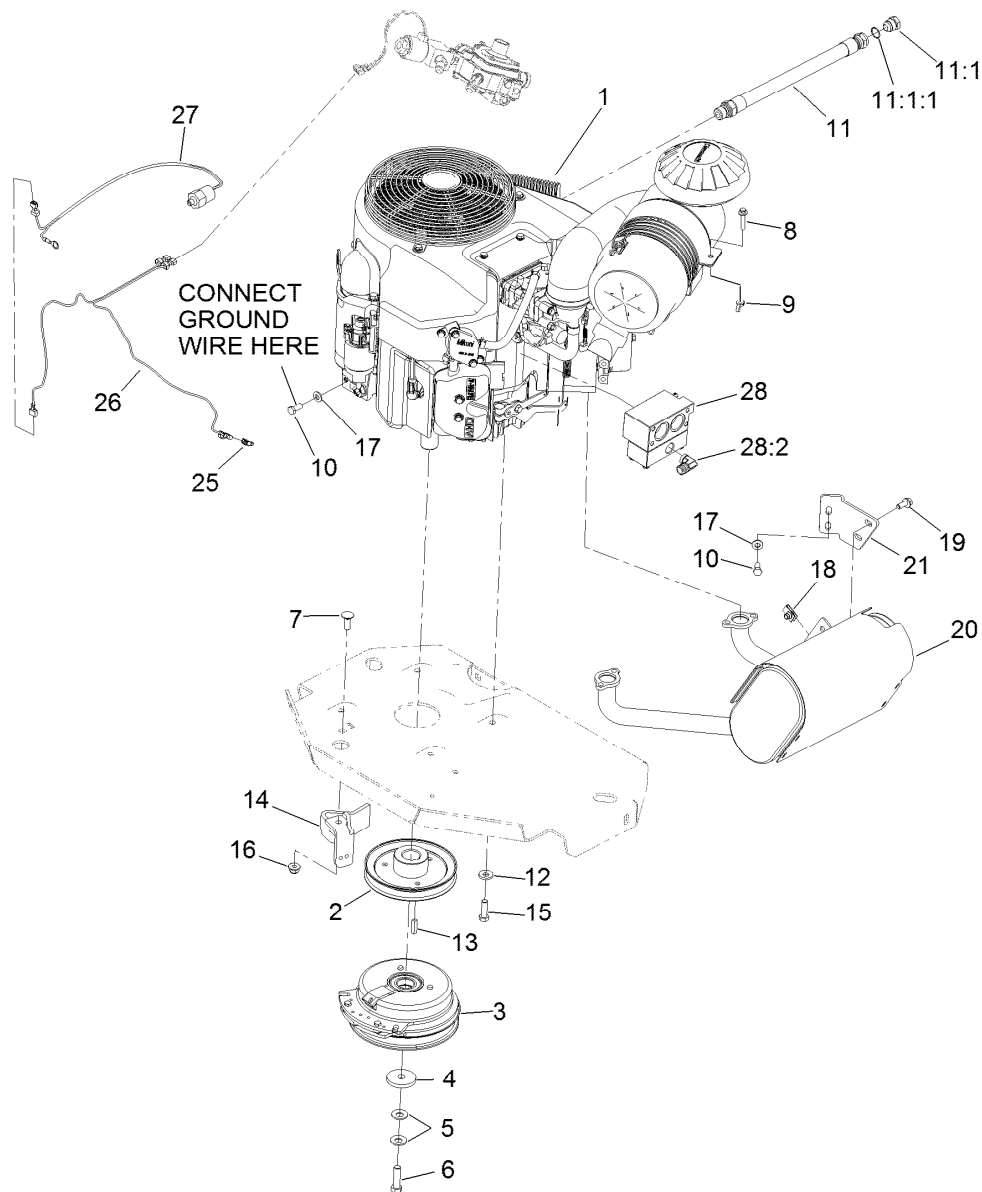

Engine, Clutch and Muffler Assembly

Ref.	Part Number	Qty.	Description	Ref.	Part Number	Qty.	Description
1		1	Engine-Kawasaki, Fx801V-S04-R ●■	13	1-807259	1	Key
2	109-9905	1	Sheave	14	116-2612-01	1	Clutch-Anchor
3	116-1620	1	Clutch Kit	15	323-7	4	Screw-HH
4	109-6919	1	Washer-Clutch	16	104-8301	1	Nut-Flange, NI
5	1-603610	2	Washer-Spring	17	1-303334	3	Washer-Spring
6	109-9761	1	Screw-HH, W/Loctite ▲	18	94-2413	2	U-Nut
7	3231-22	1	Screw-CARR	19	3234-5	2	Screw-HHF
8	3234-21	1	Screw-HHF	20	116-1712	1	Muffler
9	1-803038	1	Nut, Wing Type A	21	116-0203	1	Bracket-Muffler
10	33114-020	3	Screw-HH	25	32170-079	1	Terminal-Tab
11	116-4924	1	Engine Oil Drain Hose ASM	26	116-2857	1	Wire Harness
11:1	353-508	1	Plug-HH	27	116-2842	1	Oil Pressure Switch ASM
11:1:1	237-42	1	O-Ring	28	116-5639	1	LPG Mixer ASM
12	98-5975	4	Washer-Belleville	28:2	116-5635	1	Elbow

● Not serviced separately

▲ Use Pro-Lock, Nut Type (P/N 1-840022, .5ml tube) on threads.

■ Obtain parts from www.kawpowerpc.com

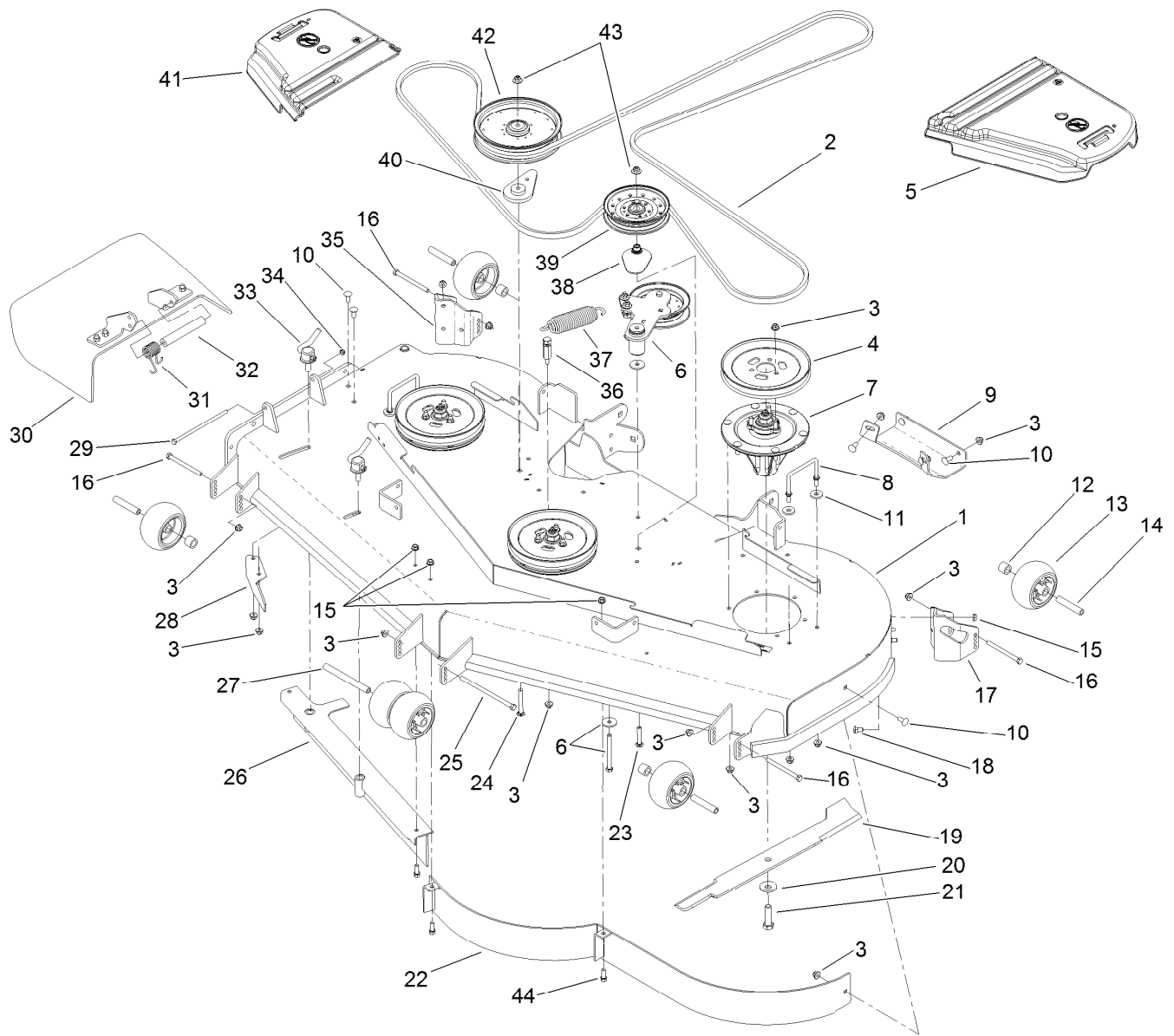

Deck Assembly

Ref.	Part Number	Qty.	Description	Ref.	Part Number	Qty.	Description
1	112-4195	1	Deck Decal ASM	19	105-7784-03	3	Blade-Hi Flow, 24.5 Inch
2	114-5859	1	Belt-V	20	103-0865	3	Washer-Blade Bolt, Heavy
3	104-8301	44	Nut-Flange, NI	21	51-4060	3	Screw-Blade
4	105-7733	3	Pulley	22	114-5843-01	1	Baffle ASM
5	109-6938	1	Cover-Belt, LH	23	3231-40	1	Bolt-CARR, Short Neck
6		1	Idler Arm ASM ●	24	3231-42	1	Screw-CARR
7	119-8500	3	Spindle ASM	25	108-5388	1	Screw-HH
8	109-6982	2	Wireform-Cover	26	105-7669-01	1	Baffle ASM
9	112-4230-01	1	Plate-Skid	27	98-5967	1	Spacer-Wheel
10	3231-27	7	Screw-CARR	28	106-3216-01	1	Baffle-Discharge
11	1-373034	4	Washer	29	322-50	1	Screw-HH
12	98-7913	4	Tube-Spacer	30	108-2792	1	Rubber Deflector ASM
13	1-603299	6	Roller-Scalp, Anti	31	108-4052	1	Spring-Torsion
14	98-7912	4	Tube-Spanner	32	105-4622	1	Spacer
15	3290-357	9	Nut-HHF, Whiz	33	107-1664	2	Lever ASM
16	323-23	4	Screw-HH	34	3296-47	1	Nut-Lock, NI
17	106-7354-01	1	Mount-Wheel, LH	35	106-7355-01	1	Mount-Wheel, RH
18	3231-1	6	Screw-CARR	36	114-5867	1	Anchor-Spring, Tall

● Not serviced separately

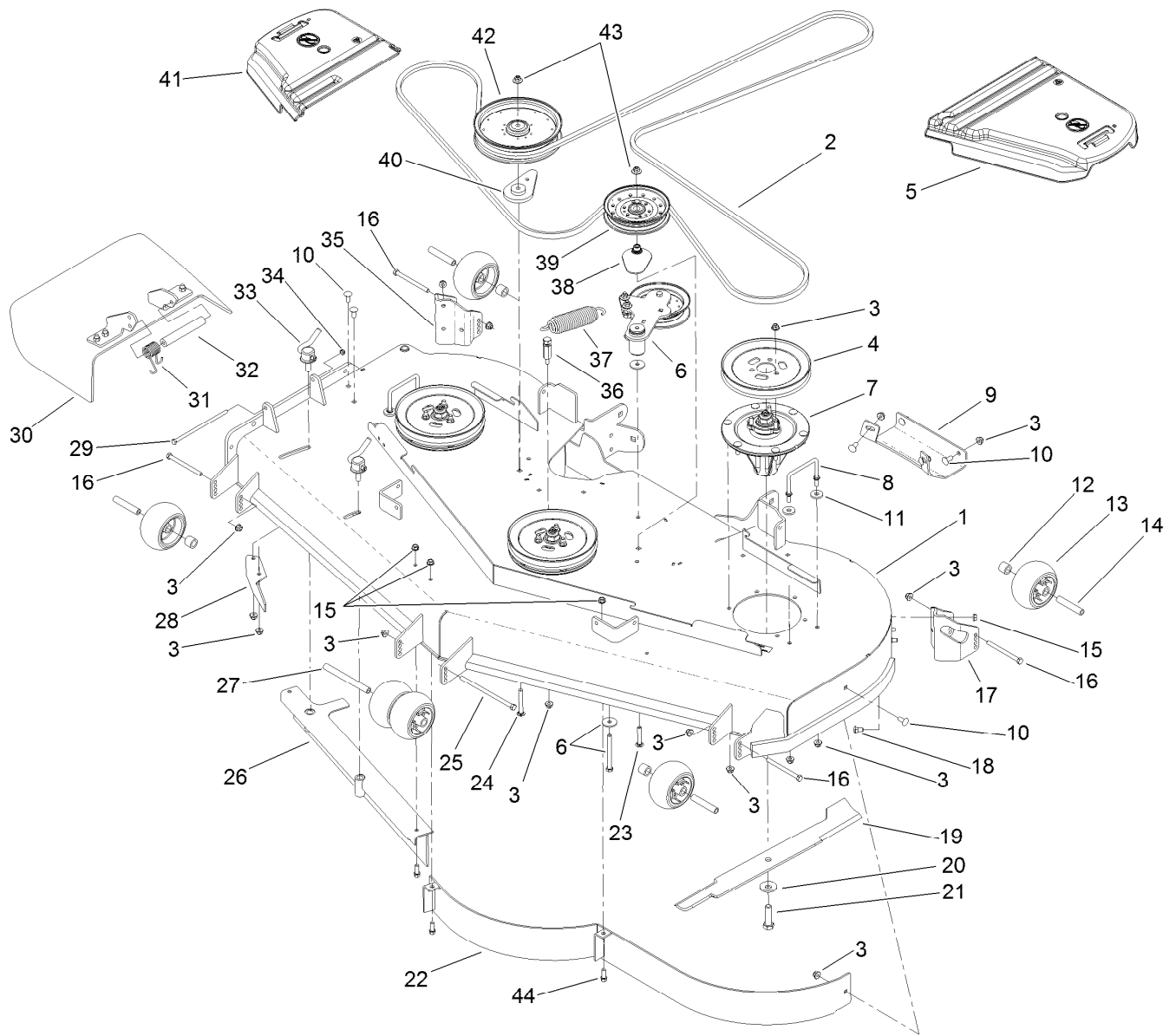

Deck Assembly (continued)

<i>Ref.</i>	<i>Part Number</i>	<i>Qty.</i>	<i>Description</i>	<i>Ref.</i>	<i>Part Number</i>	<i>Qty.</i>	<i>Description</i>
37	116-0133	1	Extension-Spring	41	116-0094	1	Cover-Belt, RH
38	109-2872	1	Spacer-Pulley	42	109-8590	1	Pulley-Idler
39	116-4670	1	Pulley-Idler, Flat	43	109-6658	2	Nut-Flange, NI
40	109-9416	1	Spacer-Idler	44	92-1624	3	Screw-HWH

● Not serviced separately

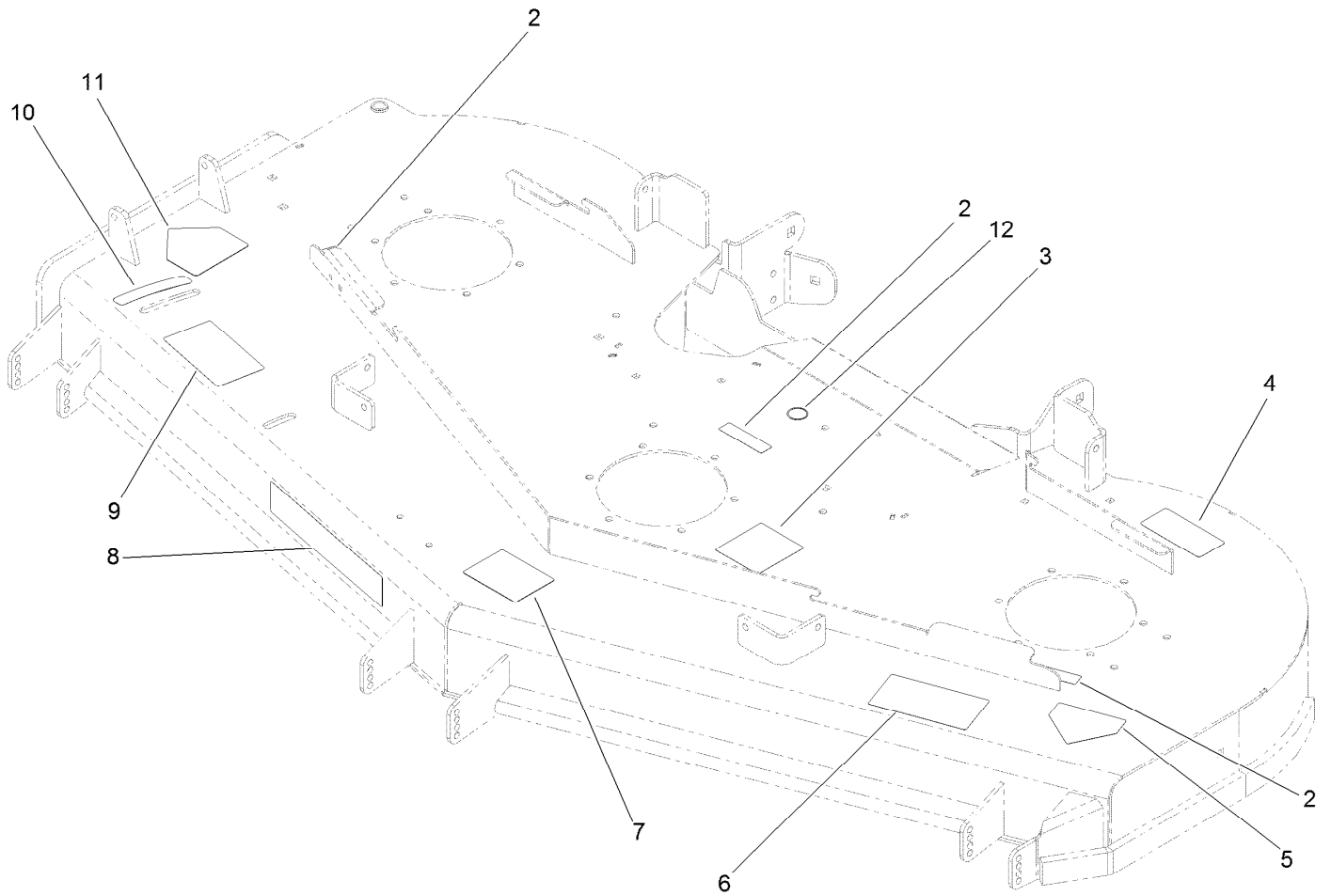

Deck Decal Assembly No. 112-4195

<i>Ref.</i>	<i>Part Number</i>	<i>Qty.</i>	<i>Description</i>
2	98-5954	3	Decal-Cover, Missing
3	115-7445	1	Decal-Routing, Deck Belt
4	68-8340	1	Decal-Torque
5	1-403005	1	Decal-Danger
6	66-1340	1	Decal-Danger, Thrown Object
7	105-7798	1	Decal-Scalp, Anti
8	107-1620	1	Decal
9	110-2068	1	Decal-Adjustment, Baffle
10	110-2067	1	Decal-Setting, Baffle
11	54-9220	1	Decal-Danger
12	58-6520	1	Decal-Grease

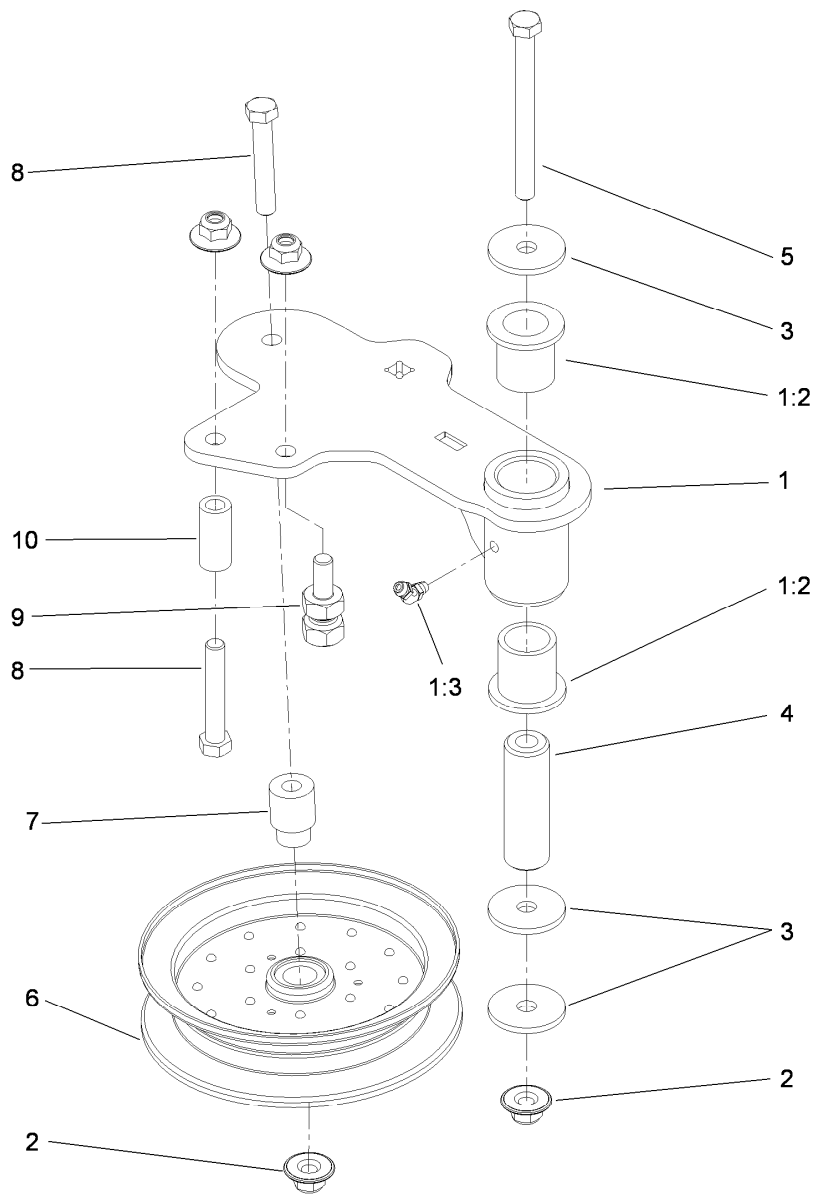

Idler Assembly

Ref.	Part Number	Qty.	Description
1	114-5870	1	Idler Arm ASM
1:2	1-303514	2	Bearing-Flanged
1:3	1481	1	Fitting-Grease
2	109-6658	4	Nut-Flange, NI
3	1-213069	3	Washer
4	114-5848	1	Spacer-Plain
5	98-5961	1	Screw-HH
6	116-4668	1	Idler-Pulley, Flanged
7	112-4212	1	Mount-Pulley
8	323-11	2	Screw-HH
9	114-5866	1	Anchor-Spring, Short
10	104-0151	1	Spacer

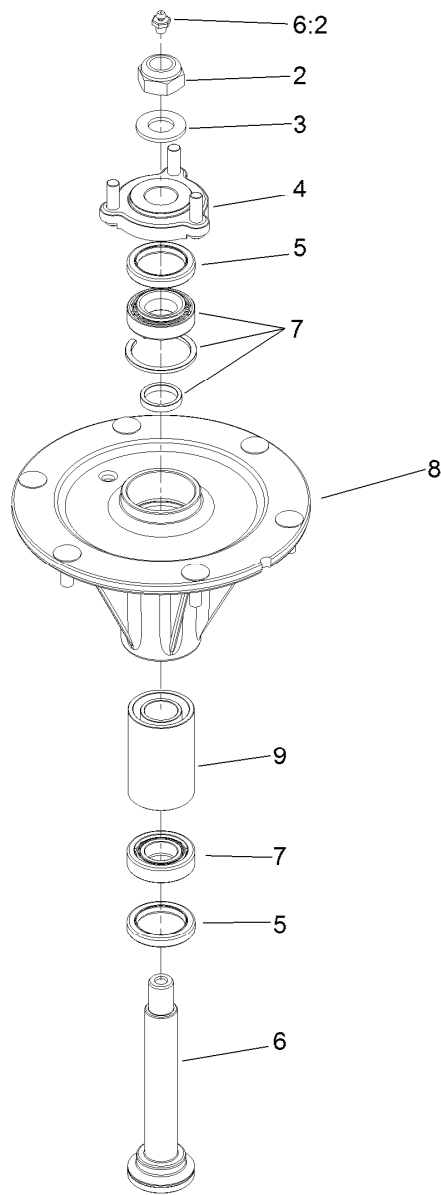

Spindle Assembly No. 119-8500

<i>Ref.</i>	<i>Part Number</i>	<i>Qty.</i>	<i>Description</i>
2	3296-67	1	Nut-Lock, NI
3	92-5836	1	Washer
4	117-6172	1	Spindle Hub ASM
5	253-133	2	Seal-Oil
6	119-8527	1	Spindle Shaft And Zerk ASM
6:2	302-2	1	Fitting-Grease
7	119-8531	1	Tapered Roller Bearing Set
8		1	Housing-Spindle ●
9	117-6185	1	Spacer Set

● Not serviced separately

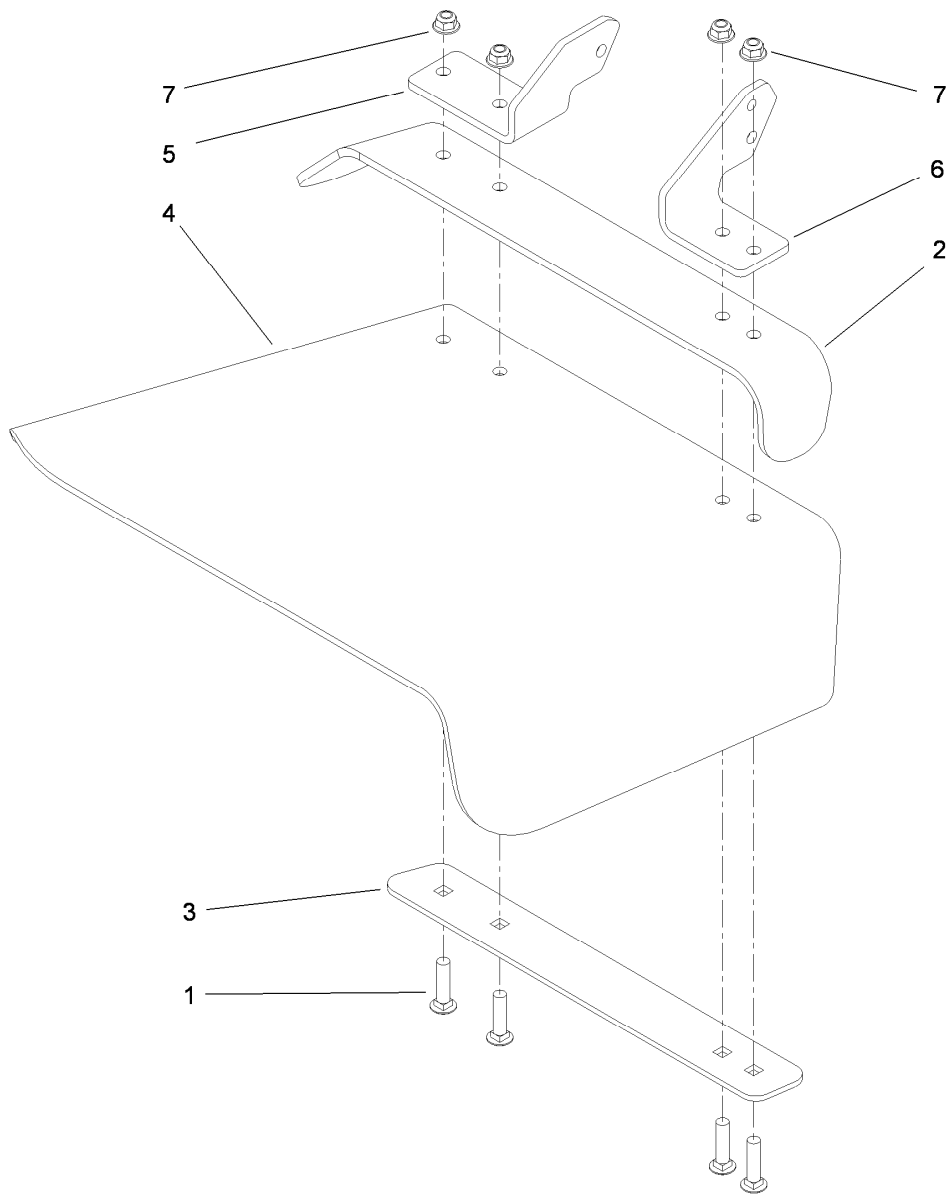

Rubber Deflector Assembly No. 108-2792

<i>Ref.</i>	<i>Part Number</i>	<i>Qty.</i>	<i>Description</i>
1	3231-4	4	Screw-CARR
2	106-3246-01	1	Deflector
3	106-3248-03	1	Strap-Discharge
4	108-5029	1	Deflector-Rubber
5	108-4059-01	1	Plate-Hinge, Rear
6	106-3253-01	1	Plate-Hinge, Front
7	104-8301	4	Nut-Flange, NI

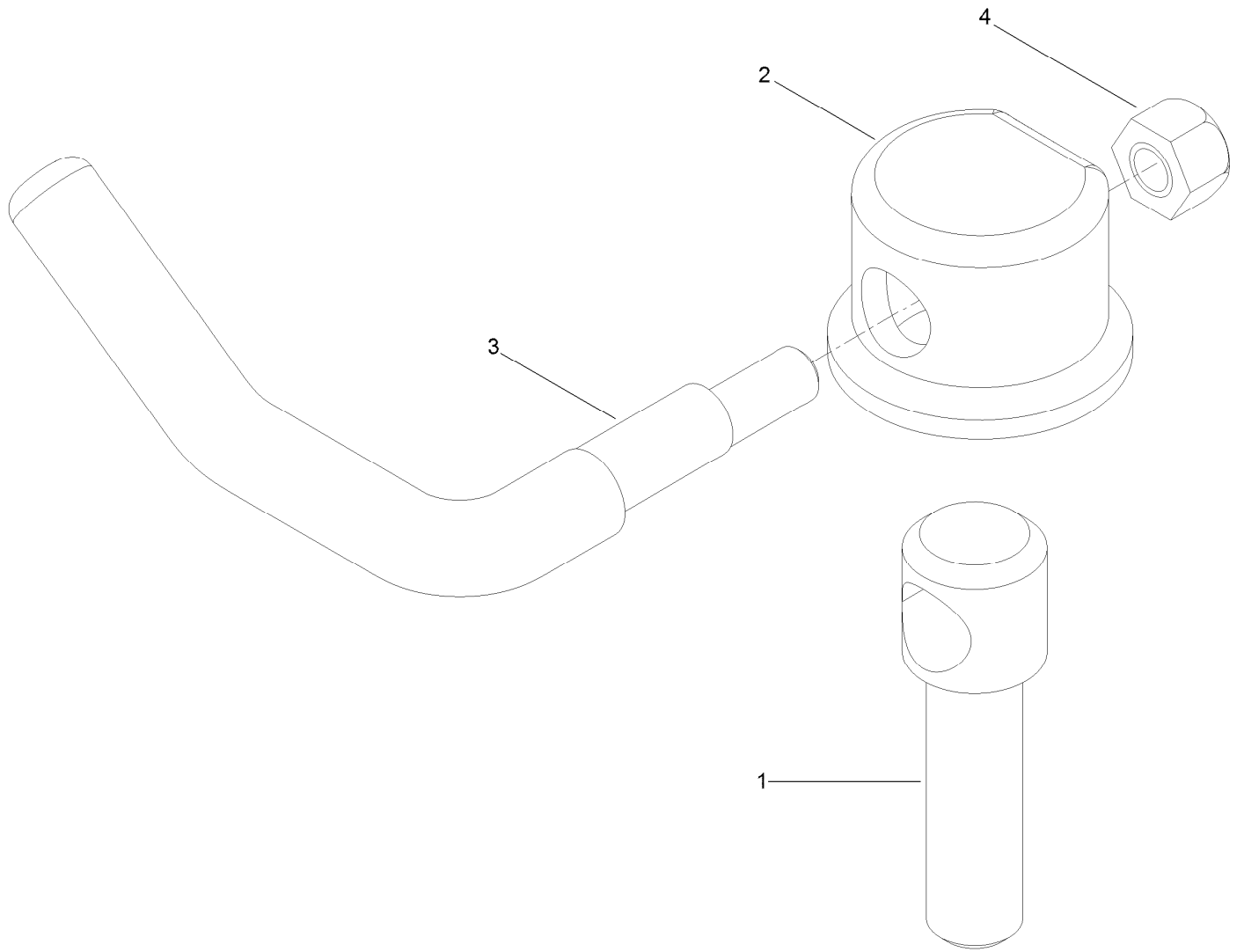

Lever Assembly No. 107-1664

<i>Ref.</i>	<i>Part Number</i>	<i>Qty.</i>	<i>Description</i>
1	106-3239	1	Screw-Lock
2	107-1644	1	Cap-Lock
3	106-3241	1	Lever-Lock
4	3296-29	1	Nut-Lock, NI

Attachments and Accessories

For 74977 Z Master Riding Mower with 72in TURBO FORCE Side Discharge Mower

Product Name	Model/Part
Deluxe Suspension Seat Kit	117-6174
Recycler Kit	115-7469
Operator-Controlled Discharge Chute Kit	117-3600
Bimini Folding Shade Assembly	115-4510
Z Stand Kit	117-0354
Light Kit.....	116-1154
Hitch Kit	109-9487
Trash Holder Kit.....	TC26
Hypr-Oil 500 (quart)	114-4713
Hypr-Oil 500 (gallon).....	114-4714
Hypr-Oil 500-5 (5 gallon).....	114-4715
Blade-Hi Flow, 24.5in.....	105-7784-03
Blade-Mid Flow, 24.5in	105-7711-03
Blade-Lo Flow, 24.5in	105-7712-03
Blade-Atomic, 24.5in	105-7719-03
Blade-Recycler, 24.5in	105-7778-03
6 Pack Blade, 24.5in Hi-Flow	108-1120
6 Pack-Blade, 24.5in Mid-Flow	110-0404
6 Pack-Blade, 24.5in Lo-Flow	110-0410
6 Pack Blade, 24.5in Atomic	108-1126
6 Pack-Blade, 24.5in Recycler.....	110-0411
Roller Striper Kit.....	115-7480
Filter Minder Gauge	99-4664
Toro Deluxe Rider Cover.....	490-7319
Spark Arrestor Screen	75-6880
Anti-Scalp Kit (Trim Side).....	108-4140

Notes:



Count on it.