



416-8 Classic
Garden Tractor

Model No. 73422 – 6900001 & Up

Parts Catalog

ORDERING REPLACEMENT PARTS

To order replacement parts, please supply: the part number, the quantity, and the description of each part desired.

Contents

Description	Page	Description	Page
Hood and Grille	1	Starter	20
Frame Steering	2	Engine Housing	21
Hoodstand, Console	3	Flywheel	22
Footrests	4	Cam & Crankshafts	23
Manual Lift System	5	Oil Fill Tube & Base	24
Clutch	6	Oil Filter	25
Brake	7	Gear Case & Ignition Controls	26
Fender, Seat	8	Ignition Electronics	27
PTO Clutch Pulley	9	Air Cleaner	28
PTO Clutch Linkage	10	Governor	29
Engine	11	Intake Manifold & Carburetor	30
Transmission	12	Choke Control	31
Wheels And Tires	13	Fuel Filter & Pump	32
Hitches	14	Engine Cylinder Block	33
Battery	15	Engine Cylinder Block	34
Fuel Tank	16	Wire Harness	35
Front Plate, Relays	17	Wire Harness	36
Transmission 8-Speed 8 Pinion	18		
Transmission 8-Speed 8 Pinion (Continued)	19	Note:	

Accessories

Description	Model / Parts No.	Description	Model / Parts No.
..			

Part Description Abbreviations

Part descriptions in this catalog may include the following abbreviations.

Abbreviation	Meaning	Abbreviation	Meaning
AR	as required	HOC	height-of-cut
ASM	assembly	HS	hex socket
CARR	carriage	HSBH	hex socket button head
DEG	degrees	HSFH	hex socket flat head
FH	flat head	HSH	hex socket head
GA	gauge	HWH	hex washer head
HF	hex flange	HWHTF	hex washer head thread forming
HFV	hex flange washer	INC	incorporated
HH	hex head	LH	left hand
HHF	hex head flange	PH	pan head
HHST	hex head self tapping	PPH	Phillips pan head
HJ	hex jam		

PTO	power take off	STD	standard
RH	right hand	TAP	self tapping
SFH	slotted fillister head	TH	truss head
SH	square head	TTH	Torx truss head
SHWH	slotted hex washer head	WH	wing head
SPH	slotted pan head		

Important Format Explanations

This catalog uses special formats to convey information in illustrations and parts lists. Specifically, one format is used in conjunction with service assemblies and another with quantities associated with reference numbers.

Service Assemblies

Parts within service assemblies have reference numbers in the form $X:Y$. X is the reference number of the service assembly and Y is a sequential number unique to each part within the service assembly.

For example, a wheel assembly might be identified by reference number 6, the tire by 6:1, the valve by 6:2, and the wheel by 6:3. When you order the assembly identified by reference number 6, you receive all parts identified by reference numbers 6:1, 6:2, and 6:3. However, you may also order any part individually.

Reference numbers of this type appear in part lists and as callouts in illustrations.

Reference Numbers with Quantities

Illustrations may have a quantity in parentheses next to a reference number, in the form $X (Y)$. X is the reference number. Y in parentheses is the quantity of the part identified by the reference number.

For example, the illustration callout 4 (2) indicates that two parts are used in that instance.

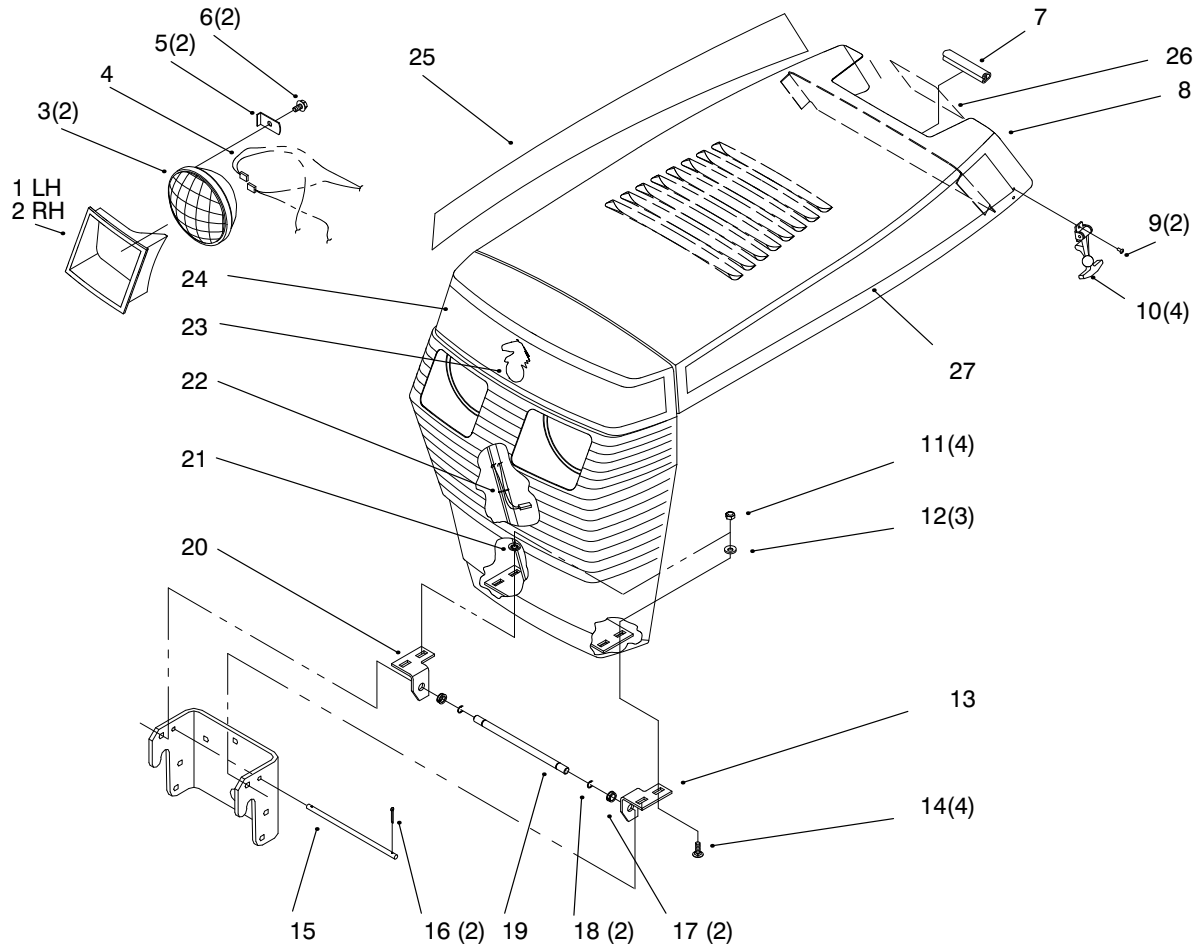

Sheet No.: 2

Hood and Grille

Ref. No.	Part No.	Qty.	Description
1	109495	1	Bezel-LH Headlight
2	109494	1	Bezel-RH Headlight
3	102881	2	Headlamp
4	114052	1	Wire Harness
5	109459	2	Clamp-Headlight
6	9266714	2	Screw-HWHTF
7	111757	1	Edging
8	112358	1	ASM-Hood & Grill
9	117432	4	Poprivet
10	117344	2	Handle-Latch
11	3296-42	4	Nut-Lock
12	3256-22	3	Washer-Flat
13	116747	1	Bracket-Grill LH
14	3229-25	4	Screw-CARR
15	101850	1	Rod-Hood Stop
16	3272-1	2	Pin-Cotter
17	5979	2	Bushing-Nyliner
18	105797	2	Ring-Ext Ret
19	116745	1	Rod-Grill Pivot
20	116746	1	Bracket-Grill RH
21	3254-2	1	Washer-Lock
22	3290-378	1	Tie-Cable
23	94-3709	1	Horsehead Logo
24	92-9826	1	Decal-Front Hood
25	94-6333	1	Decal-Hood RH Top

Ref. No.	Part No.	Qty.	Description
26	92-9837	1	Decal-Danger
27	94-6332	1	Decal-Hood LH Top

Part Identified in illustration but not in part list are not used on this model

3318-521 REV. A

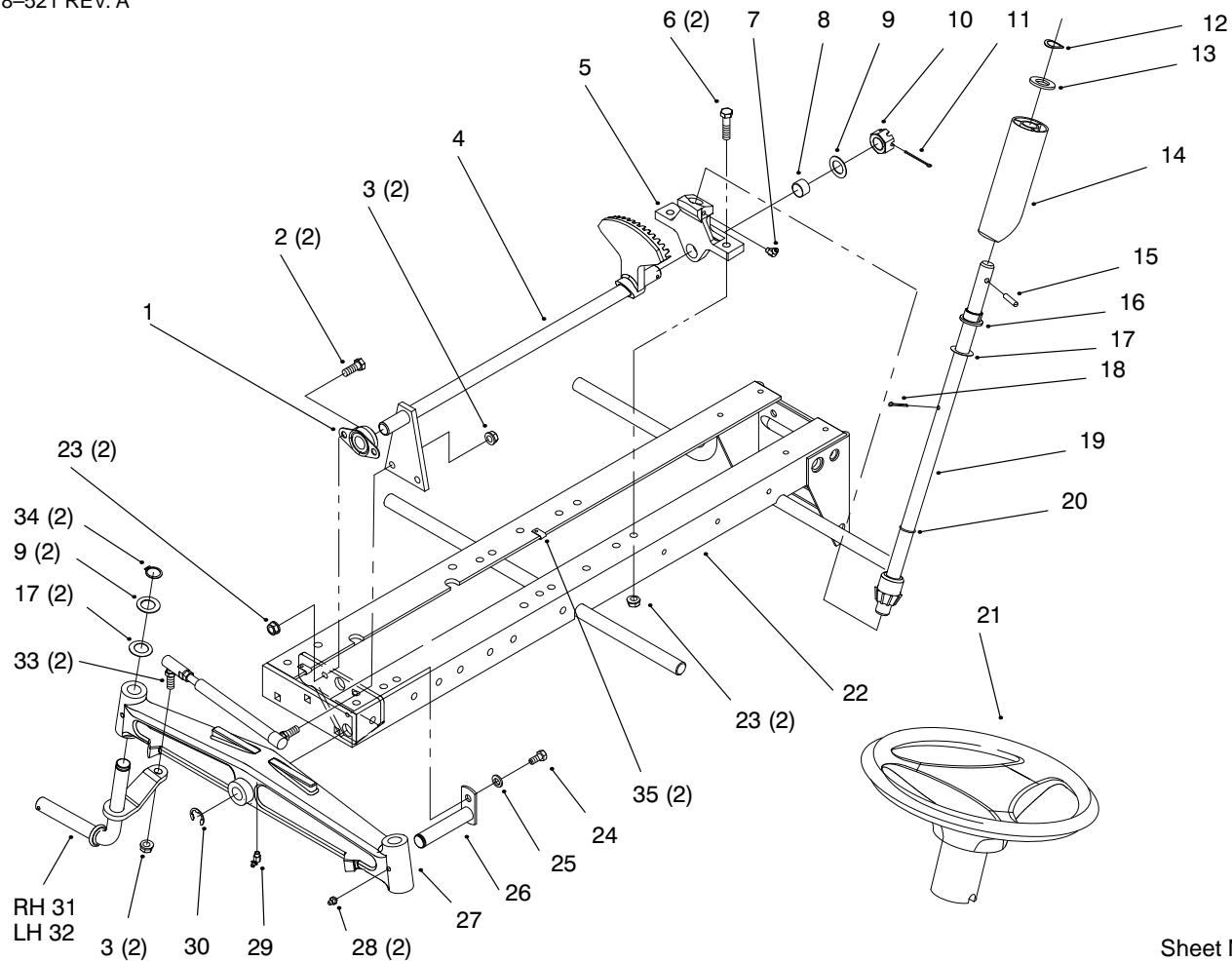

Sheet No.: 3

Frame Steering

Ref. No.	Part No.	Qty.	Description
1	6472	1	Bearing-Flanged
2	323-6	2	Screw-HH
3	3296-6	4	Nut-Lock
4	78-2880	1	Lower Steering
5	88-2710	1	Support-Lower Steering
6	323-8	2	Screw-HH
7	1481	2	Fitting-Grease
8	6397	1	Bearing-Bronze
9	1278	3	Washer-Shim
10	32136-5	1	Nut-Slotted
11	3272-19	1	Pin-Cotter
12	7896	1	Washer-Bowed
13	109262	2	Washer
14	113443	1	Tube-Steering Shaft
15	32121-111	1	Pin-Spiral
16	109189	1	Bearing-Flange
17	3272-21	1	Pin-Cotter
17	5210	14	Washer-Shim
19	92-4987	1	Steering Shaft
20	237-69	1	O-Ring
21	94-3519	1	Steering Wheel 15"
21:1	88-3870	1	Cover-Steering Wheel
22	94-3715-01	1	Frame
23	3296-39	4	Nut-Lock
24	322-1	1	Screw-HH

Ref. No.	Part No.	Qty.	Description
25	3253-4	1	Washer-Lock
26	6216	1	Pin
27	5638	1	Axle-Front
28	302-5	2	Fitting-Grease
30	5618	1	Ring-Retaining
31	113382	1	Spindle
32	113381	1	Spindle
33	78-2900	2	ASM-Tie Rod
34	32120-93	2	Snap Ring

Part Identified in illustration but not in part list are not used on this model

3318-521 REV. A

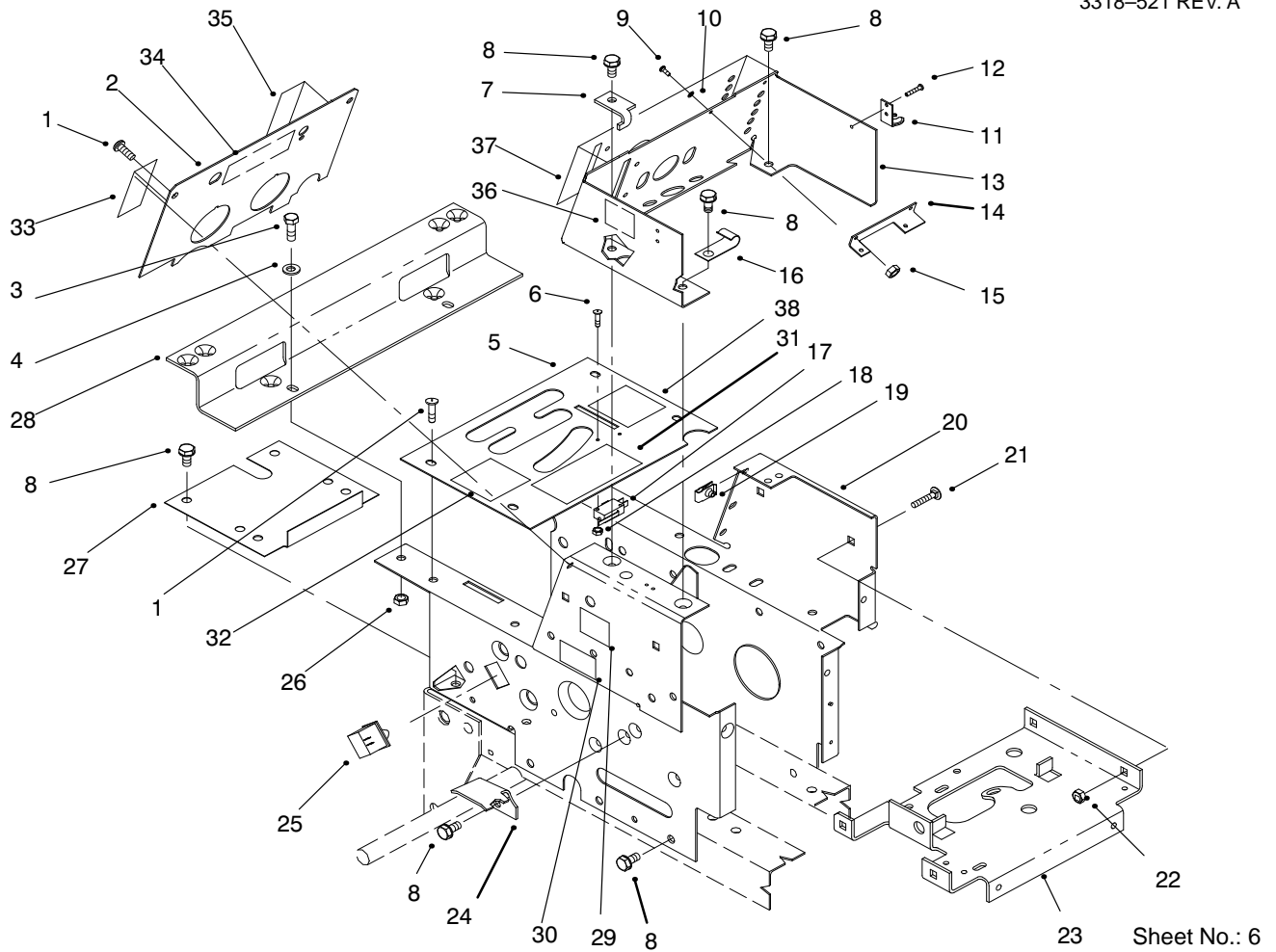

Sheet No.: 6

Hoodstand, Console

Ref. No.	Part No.	Qty.	Description
1	9108372	6	Screw-Phcr
2	94-1809	1	Plate-Hoodstand
3	322-5	2	Screw-HH
4	3256-23	2	Washer-Flat
5	111386	1	Plate-Shift Pattern
6	9109482	2	Screw-Phcr
7	112415	1	Stop-PTO
8	9266944	11	Screw-HH
9	9107622	2	Screw Phcr
10	9201504	2	Washer-Lock
11	117343	2	Latch-Hood
12	117431	4	Poprivet
13	111271	1	Console
14	112506	1	Bracket
15	9159604	2	Nut-Hex
16	111392	1	Retainer-Offset"j"
17	111332	1	Switch-Interlock
18	9157324	2	Nut-Lk
19	107069	4	Nut-Speed
20	92-1525	1	Hoodstand
21	117371	4	Screw-CARR
22	9151126	4	Nut-HH
23	78-3010	1	Bracket-Battery Support
24	88-2170	1	Bracket-Belt
25	103480	1	Switch-Interlock

Ref. No.	Part No.	Qty.	Description
26	3296-29	2	Nut-Lock
27	106250	1	Cover-Dust
28	107951	1	Bracket-Fender Front
30	94-6340	2	Decal- Model 416-8
31	92-8946	1	Decal-Danger
32	111534	1	Decal-Shift Pattern
33	111960	1	Decal-PTO Clutch
34	79-2470	1	Decal-Back Plate
35	112168	1	Decal-Lift
36	111926	1	Decal-Elec System
37	119200	1	Decal-Lower Dash
38	111510	1	Decal-Parking Brake

Part Identified in illustration but not in part list are not used on this model

3318-521 REV. A

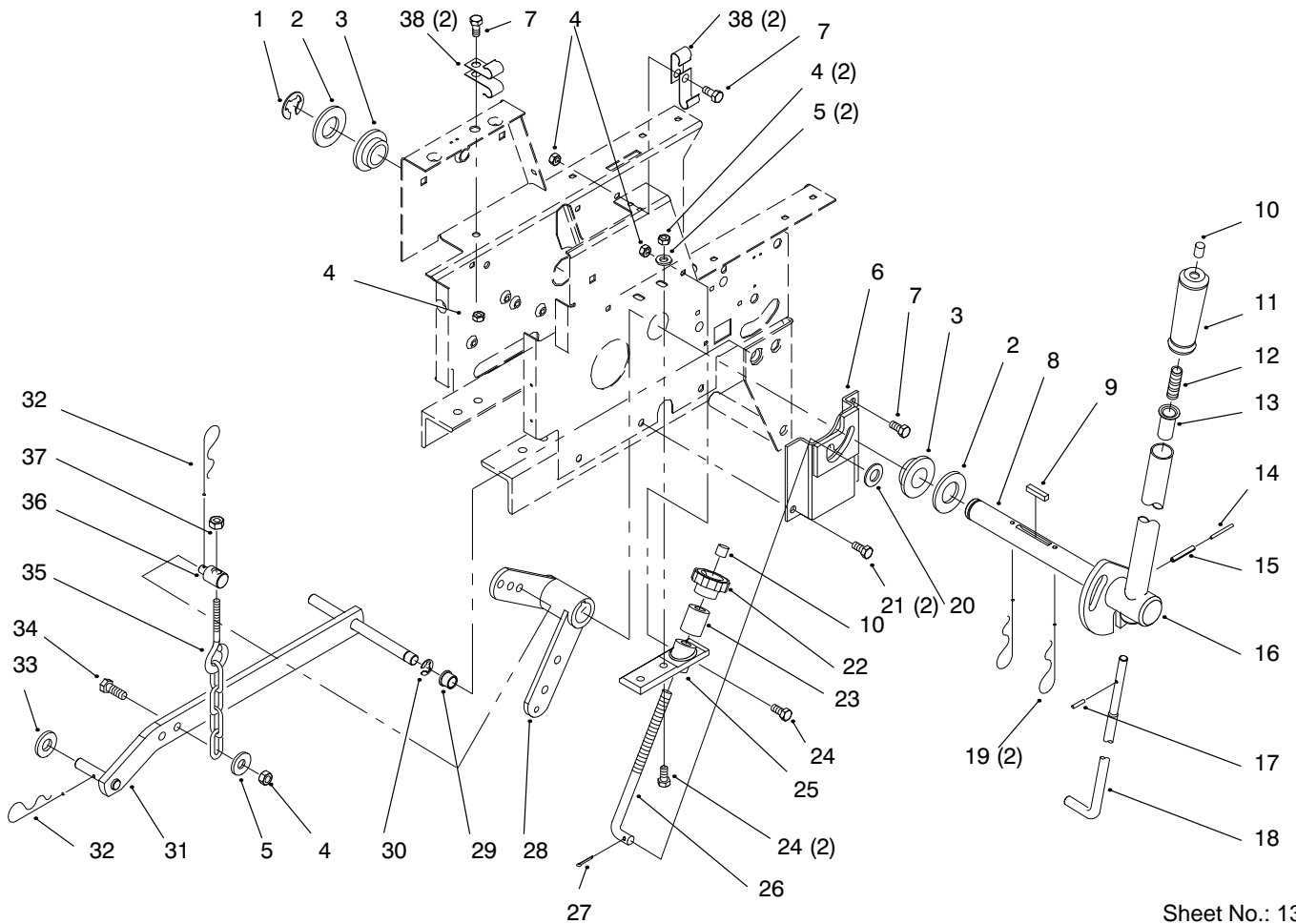

Sheet No.: 13

Manual Lift System

Ref. No.	Part No.	Qty.	Description
1	32151-91	1	Ring-Retaining
2	3256-62	2	Washer-Flt
3	106269	2	Bearing-Flange
4	3296-29	6	Nut-Lock
5	3256-23	3	Washer-Flat
6	106411	1	ASM-Lift Hgt Cont Bkt
7	9266944	1	Screw-HH
8	108565	1	Shaft-Lift Lever
9	1121	1	Key
10	105316	2	Cap-Rod
11	92-6710	1	Grip-Handle
12	3624	1	Spring-Compression
13	8130	1	Retainer-Spring
14	32121-103	1	Pin-Spring
15	32121-25	1	Pin-Roll
16	108563	1	ASM-Lift Lever
17	933148	1	Pin-Spirol
18	106257	1	Rod-Latch
19	9335074	2	Cotter-Hairpin
20	3256-5	1	Washer-Flat
21	9266964	2	Screw-HH
22	5280	1	Knob-Height Control
23	106258	1	Sleeve
24	322-5	3	Screw-HH
25	106345	1	Casting-Lift Lever

Ref. No.	Part No.	Qty.	Description
26	110653	1	Rod-Height Control
27	3272-10	1	Pin-Cotter
28	78-1550	1	Lift Lever
29	6229	1	Bearing
30	32120-47	1	Ring-Retaining
31	113445	1	ASM-Lift Bar
32	9335054	2	Hairpin
33	3256-25	1	Washer-Flt
34	322-6	1	Screw-HH
35	106522	1	Chain-Lift
36	6739	1	Trunnion
37	3296-39	1	Nut-Lock
38	8830	4	Retainer-"j"
39	322-2	2	Screw-HH

Part Identified in illustration but not in part list are not used on this model

3318-521 REV. A

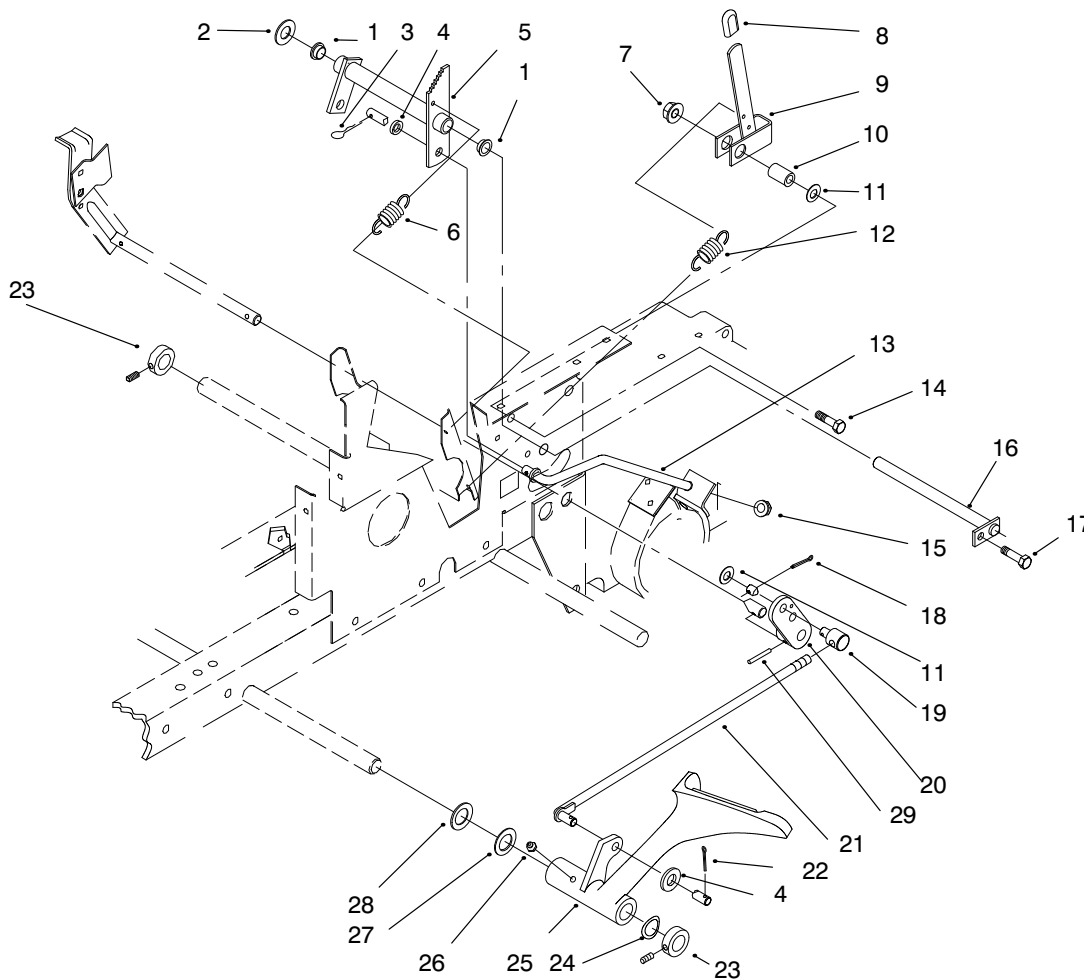

Sheet No.: 18

Clutch

Ref. No.	Part No.	Qty.	Description
1	7879	2	Bushing
2	3256-26	1	Washer-Flt
3	9335054	1	Hairpin
4	920248	2	Washer-Nylon
5	103543	1	ASM-Brake Bellcrank
6	103628	1	Spring-Extension
7	102809	1	Nut-Hex Lk
8	6820	1	Grip
9	106451	1	ASM-Parking Brake
10	102025	1	Spacer
11	3256-24	2	Washer-Flat
12	107677	1	Spring-Extension
13	105900	1	Rod-Brake Rear
14	323-9	1	Screw-HH
15	3296-39	1	Nut-Lock
16	106417	1	ASM-Rod
17	9266944	1	Screw-HH
18	3272-6	1	Pin-Cotter
19	101161	1	Trunion
20	105896	1	Arm-Clutch Rod
21	103347	1	Rod-Clutch
22	3272-10	1	Pin-Cotter
23	111383	2	Collar W/Set Screw
24	7896	1	Washer-Bowed
25	94-3703	1	Pedal-Clutch
26	302-5	1	Fitting-Grease

Ref. No.	Part No.	Qty.	Description
27	1278	1	Washer-Shim
28	9202254	1	Washer-Special
29	933190	1	Pin-Spring

Part Identified in illustration but not in part list are not used on this model

3318-521 REV. A

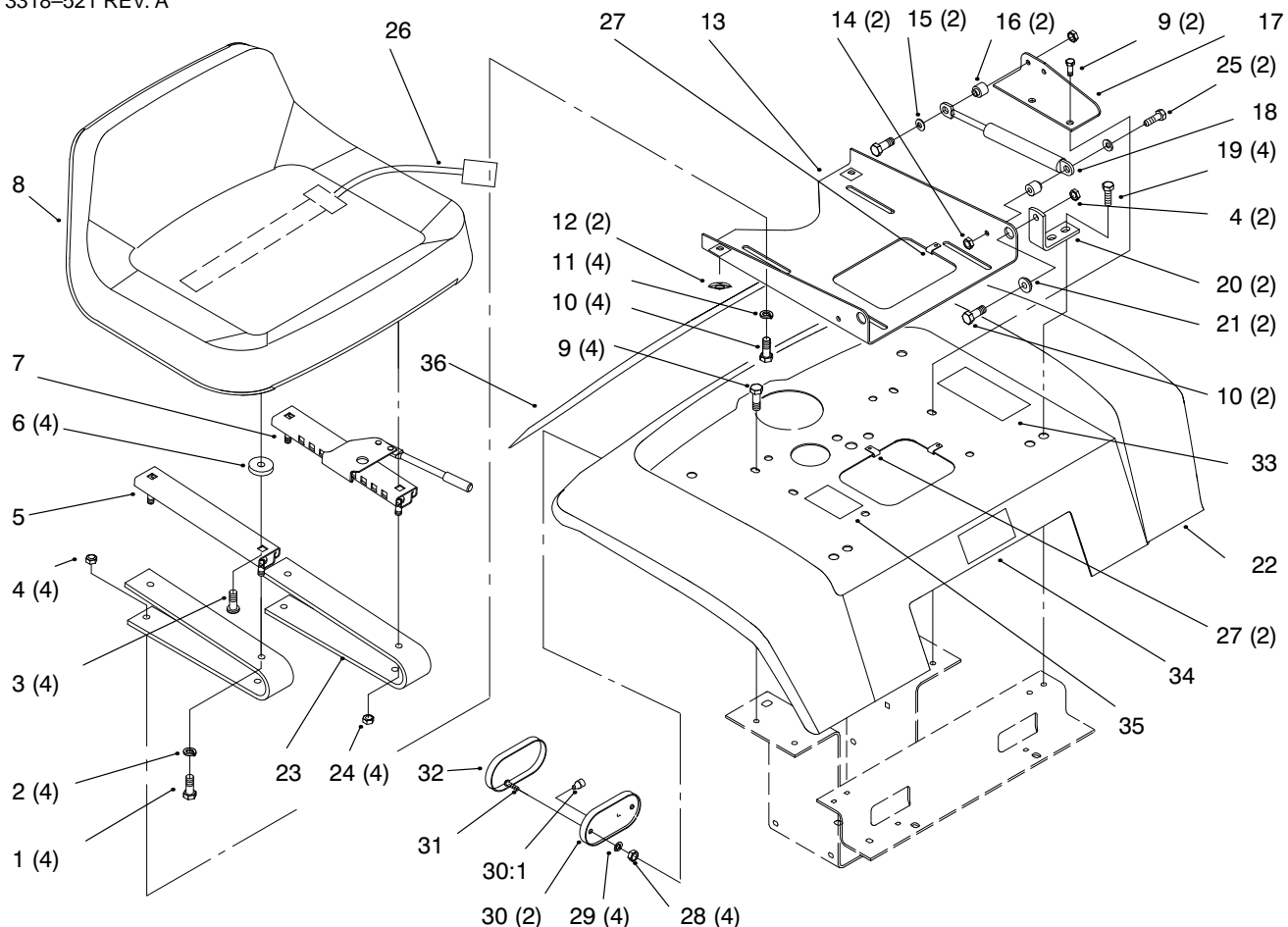

Sheet No.: 21

Fender, Seat

Ref. No.	Part No.	Qty.	Description
3	910865	4	Screw
4	3296-29	6	Nut-Lock
5	114265	1	Slide-Seat
6	109989	4	Spacer
7	114264	1	Adjuster-Seat
8	94-3719	1	Seat
10	322-4	6	Screw-HH
11	3256-23	4	Washer-Flat
12	111071	2	Bumper-Rubber
13	78-2990	1	Plate-Seat Pivot
14	3296-42	2	Nut-Lock
15	3256-22	2	Washer-Flat
16	114344	2	Spacer
17	114345	1	Bracket-Gas Spring
18	114343	1	Spring-Gas
19	9266974	4	Screw-HH
20	105524	2	Bracket-Pivot
21	105503	2	Bushing
22	94-3722-01	1	Fender
23	114263	2	Spring-Seat
24	3296-29	4	Nut-Lock
25	321-8	2	Screw-HH
26	38-1420	1	Switch-Seat
27	3023	3	Clip
28	3296-27	4	Nut-Lock
29	3254-1	4	Washer-Lk

Ref. No.	Part No.	Qty.	Description
30	105202	2	Base-Light
30:1	109045	2	Lamp-Wedge
31	3250-31	4	Screw-Phcr
32	112564	2	Lens-Light

Part Identified in illustration but not in part list are not used on this model

3318-521 REV. A

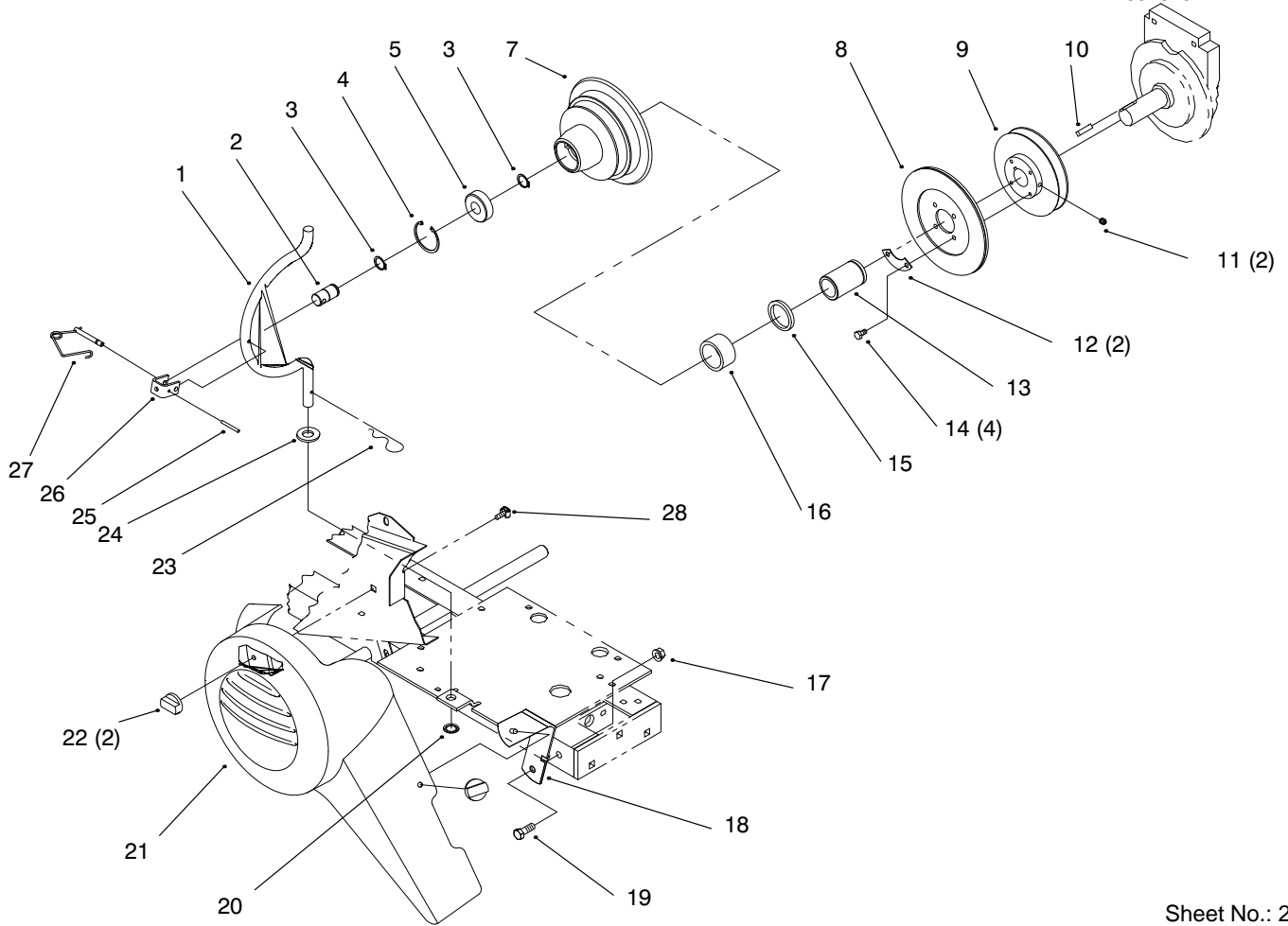

Sheet No.: 22

PTO Clutch Pulley

Ref. No.	Part No.	Qty.	Description
1	113108	1	Rod-PTO Housing
2	102872	1	Shaft-PTO
3	32120-72	2	Ring-Retaining
4	32120-62	1	Ring-Retain
5	109842	1	Bearing-Ball
7	103478	1	Housing-Clutch
8	114881	A/R	ASM-PTO Clutch Plate
8	94-6650	1	ASM-Plate
9	7466	1	Pulley-Engine
10	105453	1	Key-Sq
11	3246-2	2	Screw-HSH Set
12	6659	2	Retainer
13	6658	1	Race-Bearing
14	9080026	4	Screw-Lock
15	6663	1	Seal-Oil
16	6662	1	Bearing-Needle
17	32128-40	1	Nut-Lock
18	94-3726	1	Bracket
19	323-6	1	Screw-HH
20	106695	1	Ring-Push On
21	94-3704	1	Belt Cover-PTO
22	94-3735	2	Nut-Wing
23	9335064	1	Hairpin
24	3256-27	1	Washer-Flat
25	933274	1	Pin-Spirol

Ref. No.	Part No.	Qty.	Description
26	113107	1	Clevis
27	111314	1	ASM-Pin
28	94-3729	1	Retainer-Bolt

Part Identified in illustration but not in part list are not used on this model

3318-521 REV. A

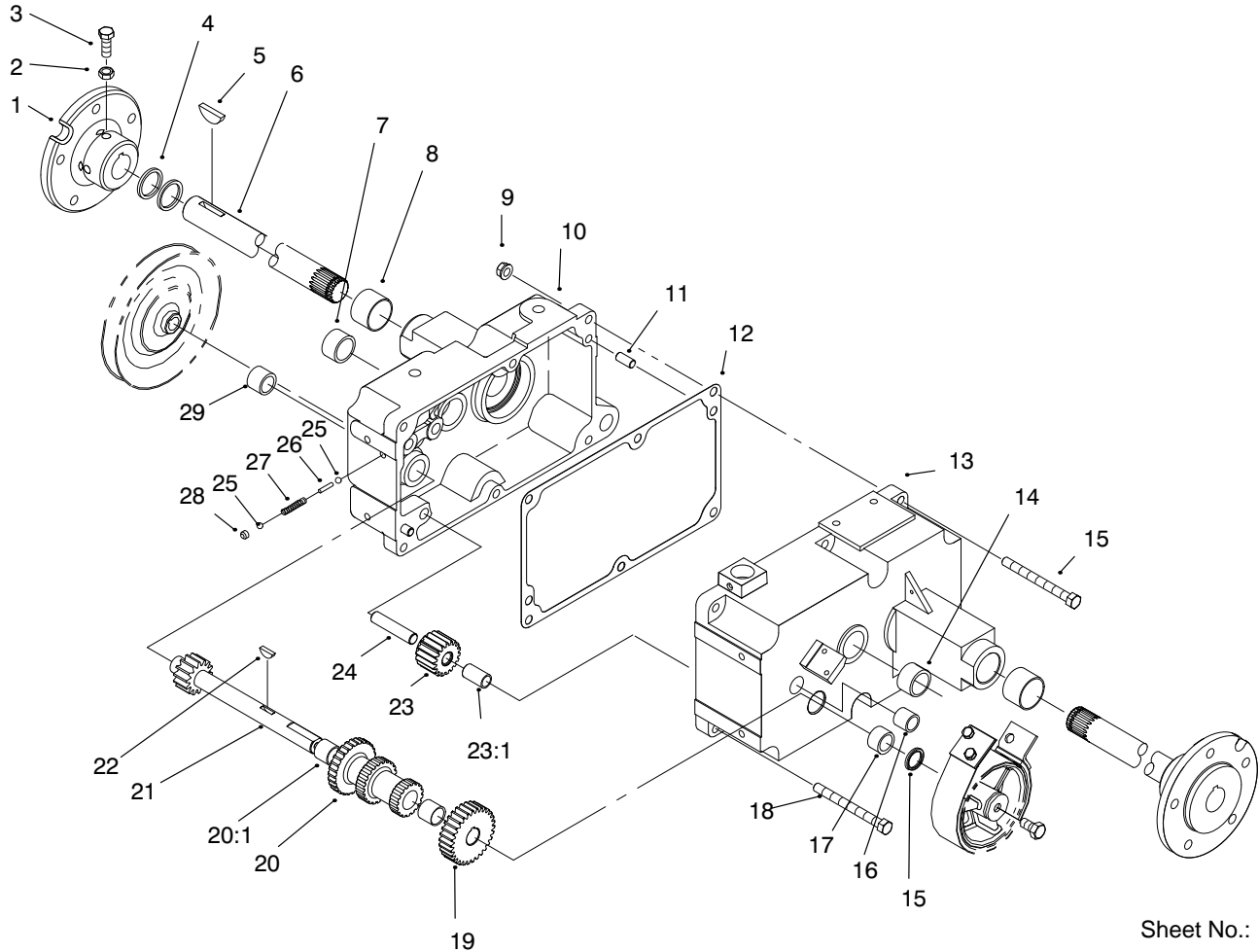

Sheet No.: 104

Transmission 8-Speed 8 Pinion

Ref. No.	Part No.	Qty.	Description
1	105763	2	Hub-Wheel
2	3218-3	4	Nut-HJ
3	3243-5	4	Screw-Set
4	100443	4	Oil Seal
5	937108	2	Woodruff Key
6	105875	2	Axle-Rear
7	1532	2	Bearing-Needle
8	9416	2	Bearing
9	3296-39	6	Nut-Lock
10	111200	1	Case Trans RH
11	3915	2	Dowel Pin
12	3912	1	Gasket Transmission
13	111198	1	Case Trans LH
14	323-16	1	Screw-HH
15	100441	1	Seal-Oil
16	323-11	5	Screw
16	83-2890	1	Bearing-Needle
17	1523	1	Needle Bearing
19	116636	1	ASM Shift Fork
19	3527	1	Gear Cluster Shaft
19:	7209	1	Fork ASM Shift
20	7269	1	ASM Cluster Gear
20:1	1504	2	Bushing Bronze
21	83-3530	1	Shaft-Cluster
23	4204	1	ASM-Reverse Idler Gear

Ref. No.	Part No.	Qty.	Description
23:1	1516	1	Bushing
23:	92-6649	1	Gear-Spur
24	3909	1	Differential Pin
26	5614	1	Shift Pin
27	106030	2	Spring-Shift Stop
28	1243	1	Plug Cup
29	1529	1	Bearing-Needle

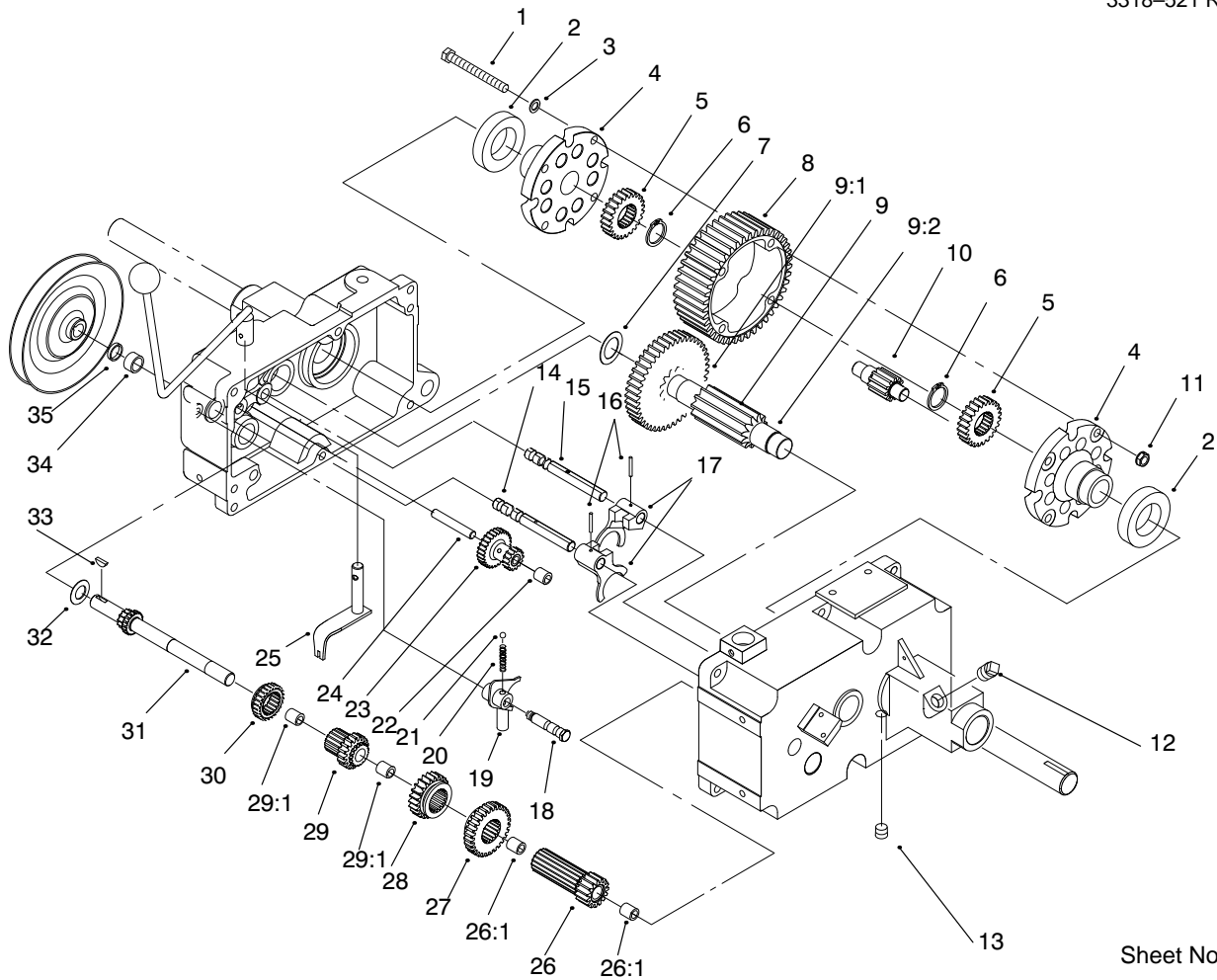

Sheet No.: 105

Transmission 8-Speed 8 Pinion (Continued)

Ref. No.	Part No.	Qty.	Description
1	911423	4	Bolt-Hex
2	111199	2	Bearing Ball
3	107374	4	Washer
4	111196	2	End Cap-Differential
5	101889	2	Axle Diff Gear
6	105876	2	Snap Ring
8	105061	1	Gear Diff Bull 43t
9	102974	1	Assy-Gear (Press)
9:9	101625	1	Pinion Shaft
9:9	101626	1	Gear-44t
10	101623	8	Pinion Gear 11t
11	108881	4	Nut-Hex
12	281-2	1	Plug-Pipe
13	281-10	1	Plug-Pipe
14	5615	1	Shift Rail
14	7208	1	Shaft Reduction Gear
15	5616	1	Shift Rail Rear
16	933156	2	Pin-Hd Spirol
17	3503	2	Shift Fork
18	7213	1	Bolt Detent
21	3517	3	Ball-Detent
22	7207	2	Needle Bearing
23	7206	1	Reduction Gear
24	7214	1	ASM Shift Lever
24:1	7215	1	Shift Lever
24:2	7216	1	Shaft Shift Lever

Ref. No.	Part No.	Qty.	Description
26	111099	1	Gear
26	5175	1	ASM Gear
26:1	1518	2	Needle Bearing
27	5174	1	Gear-Low And Reverse
28	5173	1	Gear-Hi And 2nd
29	111096	1	Gear
29	7204	1	ASM Gear
29:1	1518	2	Needle Bearing
31	7201	1	Input Shaft
32	7418	1	Washer
33	937089	1	Key-Woodruff
34	1542	1	Needle Bearing
35	100442	1	Oil Seal
56	7205	1	Sliding Gear

Part Identified in illustration but not in part list are not used on this model

3318-521 REV. A

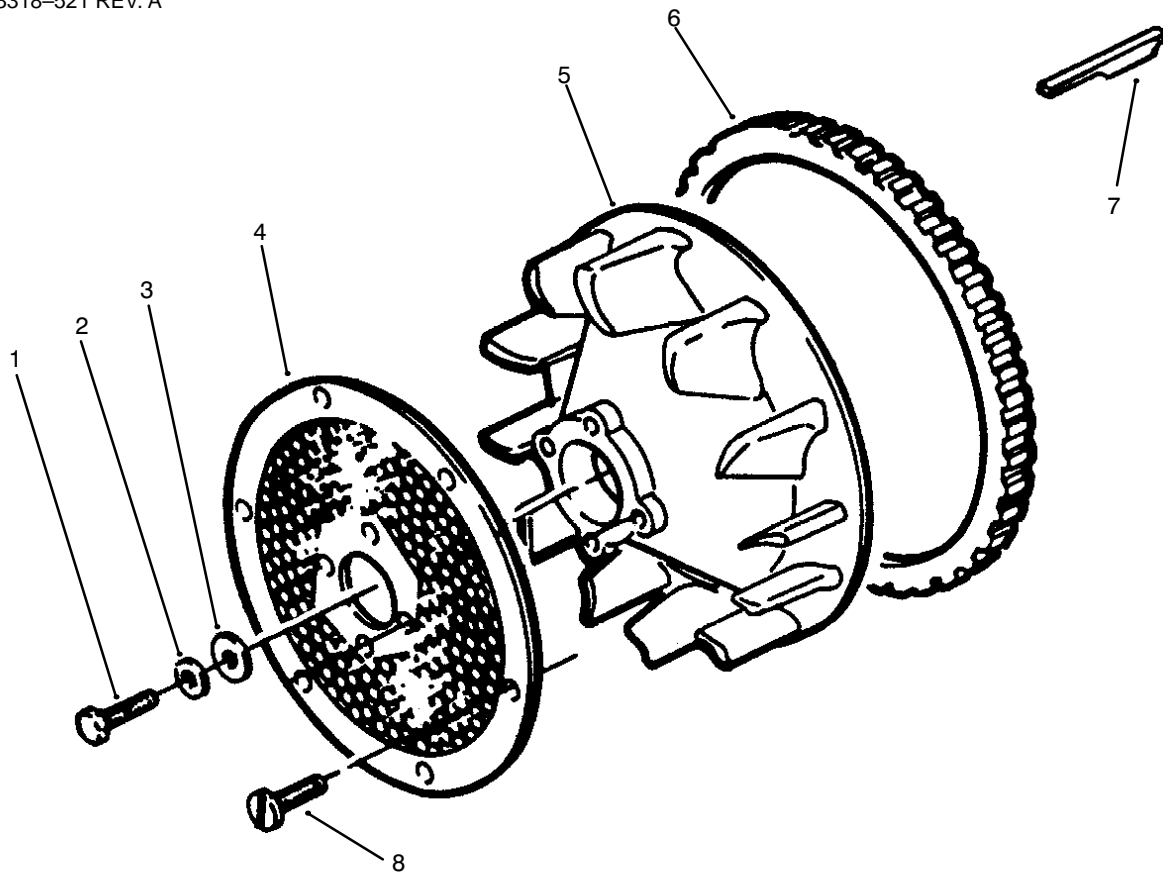

Sheet No.: 403

Flywheel

Ref. No.	Part No.	Qty.	Description
1	57-8150	1	Screw-Cap Hex Hd
2	82-1320	1	Washer-Flat
3	59-0810	1	Washer-Flat
4	79-6440	1	Screen-Air Inlet
5	71-5920	1	Flywheel Incl 6
6	57-8180	1	Gear-Ring
7	71-6190	1	Key-Flywheel
8	71-6340	6	Spring-Compression

Ref. No.	Part No.	Qty.	Description

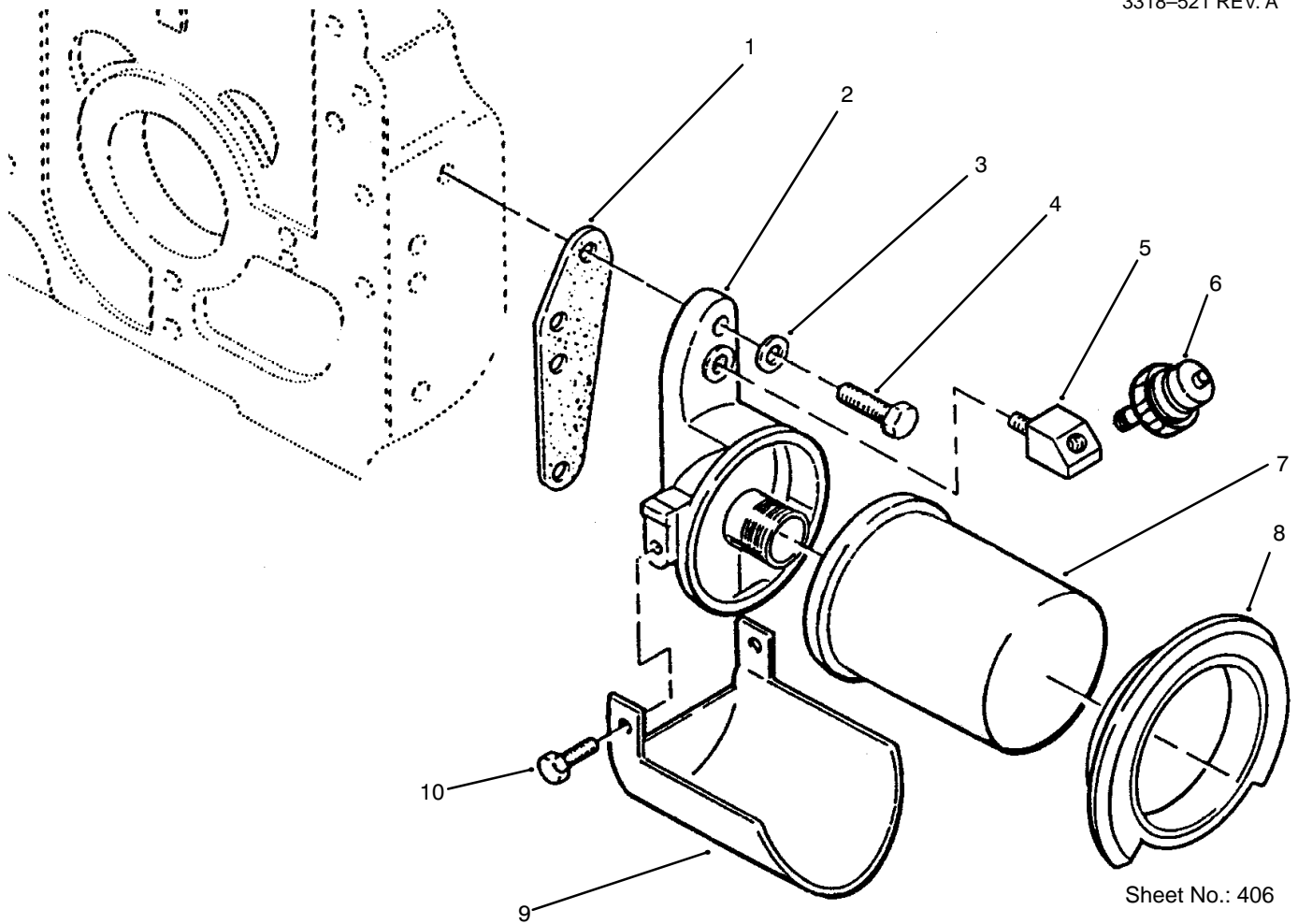

Sheet No.: 406

Oil Filter

Ref. No.	Part No.	Qty.	Description
1	79-6470	1	Gasket-Adapter
2	82-0500	1	Adapter-Oil Filter
3	57-9750	2	Washer-Flat
4	NN10373	2	Screw-Cap Hex Hd
5	59-0640	1	Elbow-Street 45 Degree
6	94-1845	1	Switch-Pressure
6	94-1845	1	Switch-Pressure
7	NN10143	1	Filter-Oil
8	82-0680	1	Filter-Gasket Oil
9	NN10894	1	Drain-Oil Filter
10	82-1510	2	Screw-Hex Hd

Ref. No.	Part No.	Qty.	Description

Part Identified in illustration but not in part list are not used on this model

3318-521 REV. A

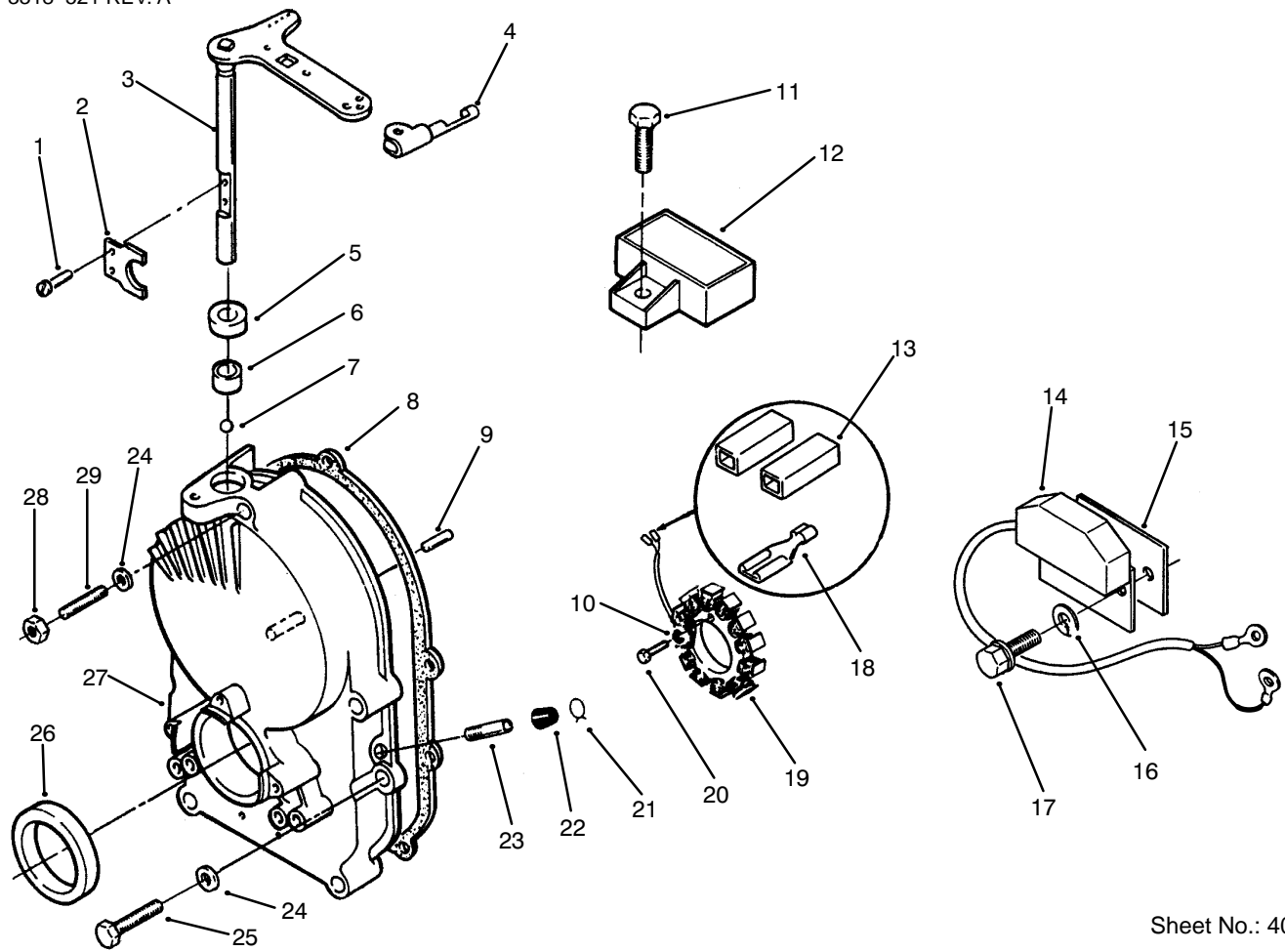

Sheet No.: 407

Gear Case & Ignition Controls

Ref. No.	Part No.	Qty.	Description
1	59-0950	2	Screw-Mach Pan Hd
2	59-0420	1	Yoke-Governor
3	NN10826	1	Shaft & Arm Governor
4	94-6680	1	Clip-Retaining
5	57-9570	1	Seal-Oil
6	57-9650	1	Bearing-Governor
7	57-9630	1	Bearing-Ball Gov Shaft
8	71-6360	1	Gasket-Mntg
9	59-0740	1	Pin-Dowel
10	3253-2	3	Washer-Lock #10
11	59-1080	1	Screw-Cap Flg Hd
12	57-9430	1	Regulator-Voltage 20 Amp
13	82-1000	2	Body-Term Conn Kit
14	71-6380	1	Control-Ignition
15	71-6410	1	Insulator-Ignition
16	82-1660	2	Washer-Lock
17	NN10394	2	Screw-Hex Washer Hd
18	59-0590	2	Terminal-Stator Leads
19	92-0967	1	Stator
20	82-1500	3	Screw-Mach Hex Hd
21	57-9550	1	Clamp-Vacuum Port Cap

Ref. No.	Part No.	Qty.	Description
22	59-0370	1	Cap-Vacuum Port
23	59-0360	1	Tube-Vacuum Port
24	57-9750	5	Washer-Flat
25	NN10545	4	Screw-Hex Hd
26	57-9580	1	Seal-Oil
27	NN10825	1	Kit-Gearcase
28	59-1130	1	Nut-Hex
29	59-0790	1	Stud-Gear Cover

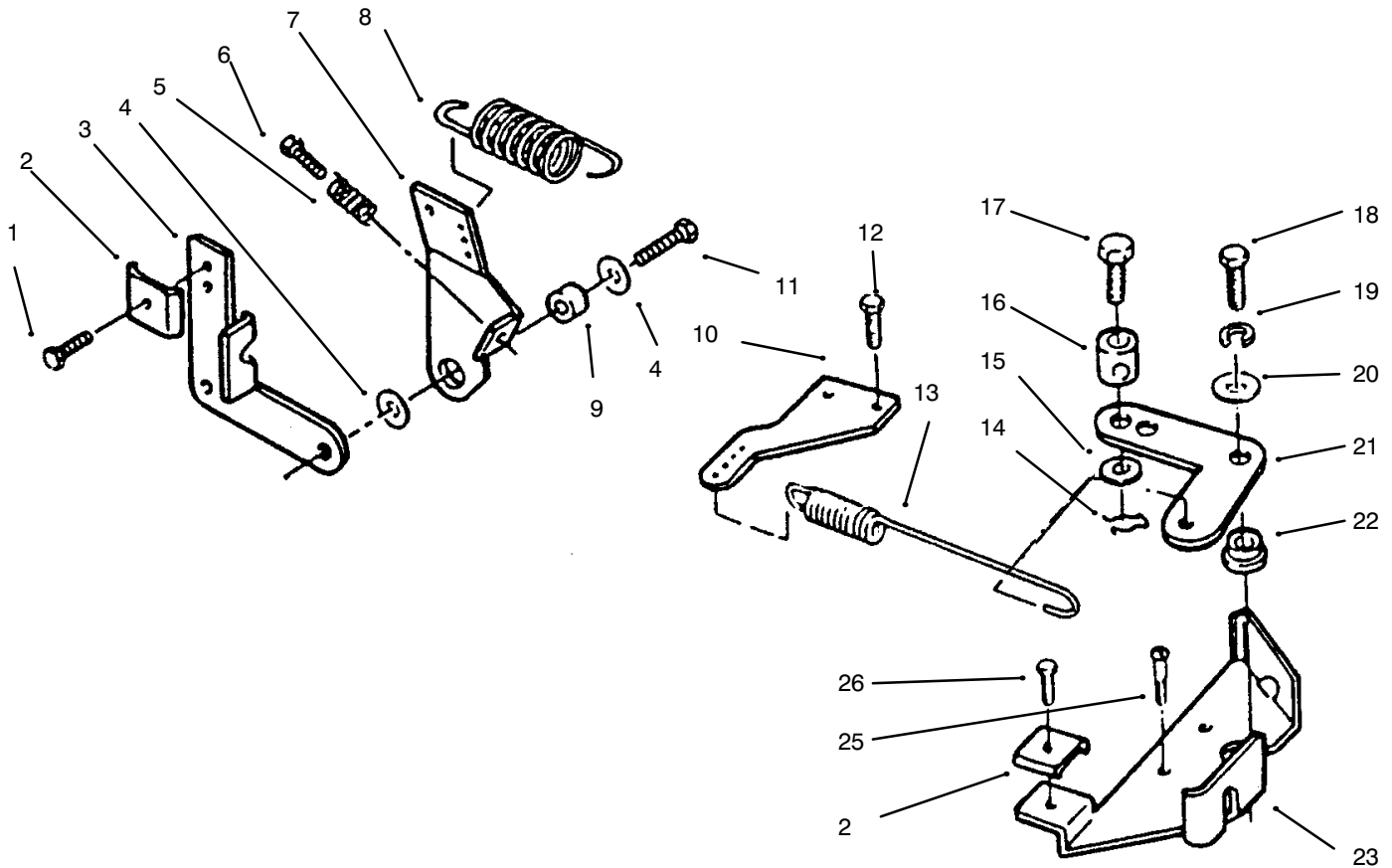

Sheet No.:410

Governor

Ref. No.	Part No.	Qty.	Description
1	72-3900	1	Screw-Tapping Hex Hd
2	57-9190	2	Clamp-Cable
3	79-6360	1	Bracket-Cable
4	59-0830	2	Washer-Flat
5	59-0430	1	Spring-Idle Setting
6	59-1030	1	Screw-Tapping Hex Hd
7	92-0922	1	Arm-Governor Control
8	57-9100	1	Spring-Governor
9	57-9120	1	Bushing-Control Arm
10	79-6420	1	Adapter-Governor Arm
11	59-1100	1	Screw-Lock Hd
12	NN10403	1	Screw-Self TAP Flg Hd
13	NN10932	1	Spring-Governor
14	59-0720	1	Pin-Cotter
15	201270	1	Washer
16	57-9120	1	Bushing-Control Arm
17	72-3890	1	Screw-Hex Hd
18	82-1370	1	Screw-Hex Hd
19	82-1620	1	Washer-Lock
20	59-0830	1	Washer-Flat
21	201256	1	Link-Governor Control
22	79-6400	1	Bushing-Governor Cont
23	79-6390	1	Bracket-Governor Cont

Ref. No.	Part No.	Qty.	Description
25	201327	1	Screw-Self TAP Flg Hd
26	59-1000	3	Screw

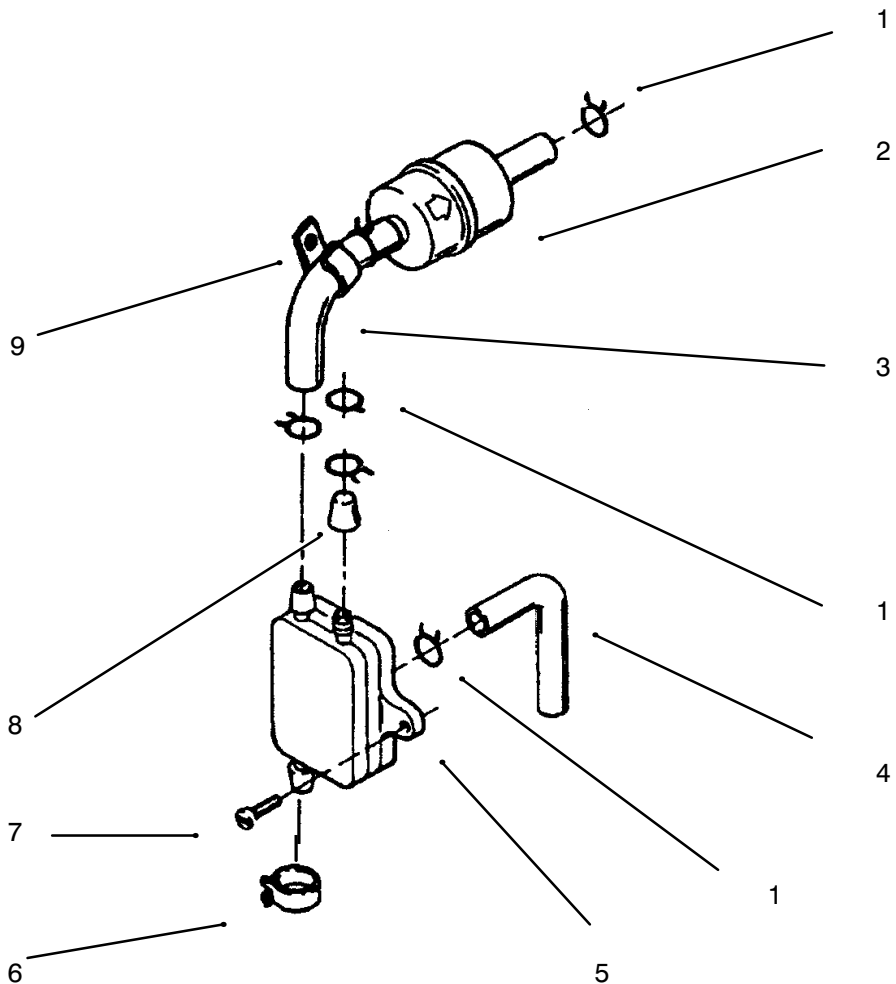

Sheet No.: 413

Fuel Filter & Pump

Ref. No.	Part No.	Qty.	Description
1	82-1080	6	Clamp-Hose .50" Dia
2	71-5960	1	Filter-Fuel
3	NN10790	1	Line-Fuel 12"
4	NN10302	1	Line-Fuel 7"
5	57-9080	1	Pump-Fuel
6	950154	2	Clamp-Corbin
7	59-1050	2	Screw St Pan Hd
8	NN10211	1	Cap-Fuel Fitting
9	NN10048	1	Clamp

Ref. No.	Part No.	Qty.	Description

Engine Cylinder Block

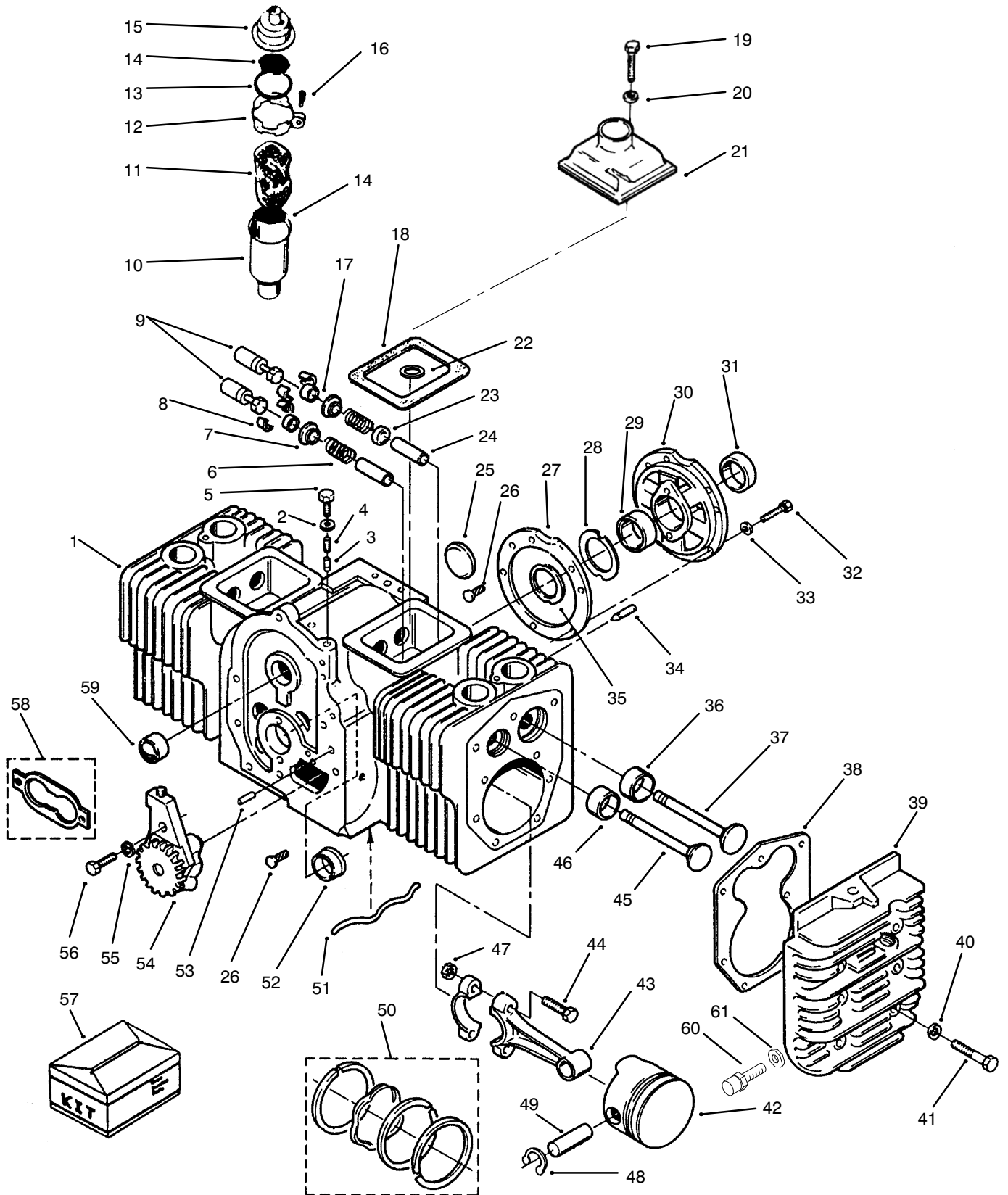

Part Identified in illustration but not in part list are not used on this model

3318-521 REV. A

Engine Cylinder Block

Ref. No.	Part No.	Qty.	Description
1	NN10850	1	Block-Cylinder (Short)
2	57-9760	1	Washer-Flat
3	57-8470	1	Plunger-Bypass Valve
4	59-0280	1	Spring-Bypass Valve
5	59-0910	1	Screw-Cap Hex Hd
6	71-5790	4	Spring-Valve
7	71-5800	4	Washer-Valve Spring
8	NN10082	8	Lock-Valve Spring
9	57-8450	4	Tappet-Valve STD
*	59-0260	4	.002" Oversize
10	82-0540	1	Tube-Breather
11	57-8580	1	Baffle-Breather Tube
12	82-0530	1	Clamp-Tube
13	82-0570	1	O-Ring-Cap
14	82-0560	2	Screen-Tube
15	82-0550	1	Cap & Valve-Breather
16	82-1480	1	Screw-TAP Round Hd
17	71-5830	4	Cap-Valve
18	57-8280	2	Gasket-Cover
19	NN10370	2	Screw-Cap Hex Hd
20	57-9740	2	Washer-Flat
21	NN10821	1	Cover-Valve
22	59-0820	1	Washer-Flat
23	71-6180	2	Seal-Valve
24	71-6250	2	Guide-Valve
*	71-6260	2	Guide-Valve
25	57-9690	1	Plug-Welch
26	59-0730	4	Pin-Drive
27	57-8010	1	Gasket-Bearing Plate
28	57-8170	A/R	Shim-Crankshaft .005"
29	57-8050	1	Bearing-Crankshaft Rear
*	57-8060	1	.010" Undersize
*	59-0020	1	.002" Undersize
*	59-0030	1	.020" Undersize
*	59-0040	1	.030" Undersize
30	82-0020	1	Plate-Bearing
31	57-9590	1	Seal-Oil
32	59-0880	5	Screw-Cap Flg Hd
33	3253-5	5	Washer-Lock
33	82-1310	5	Washer-Flat
34	3247-4	2	Screw-HS
35	57-8160	2	Washer-Thrust
36	59-0050	2	Insert-Valve Seat Intake
*	59-0080	2	.010" Oversize
37	71-5770	2	Valve-Intake
38	57-8330	2	Gasket-Head
39	59-0180	1	Head-Cylinder RH
*	71-5810	1	Head-Cylinder LH
40	57-9770	18	Washer-Flat
41	59-0900	18	Screw-Cap Hex Hd
42	82-1800	2	Piston STD INC 48-49
*	92-0902	2	.010" Oversize
	92-0903	2	.020" Oversize
*	92-0904	2	.030" Oversize
43	NN10125	2	Rod W/Bolts & Nuts STD
43	NN10126	2	Rod W/Bolts & Nut

Ref. No.	Part No.	Qty.	Description
			.010"
43	NN10127	2	Rod W/Bolts & Nut .020"
43	NN10128	2	Rod W/Bolts & Nut .030"
44	57-8410	4	Bolt-CoNNeCting Rod
45	71-5780	2	Spring-Clutch
46	59-0100	2	Insert-Valve Seat Exh
*	59-0110	2	.002" Oversize
*	59-0120	2	.005" Oversize
*	59-0130	2	.010" Oversize
*	59-0140	2	.025" Oversize
47	57-9790	4	Nut
48	57-9720	4	Ring-Retaining
49	71-6310	2	Pin-Piston
50	92-0905	2	Kit-Ring Piston STD
*	92-0906	2	.005" Oversize
*	92-0907	2	.010" Oversize
*	92-0908	2	.020" Oversize
*	92-0909	2	.030" Oversize
51	59-0290	1	Tube-Oil
52	57-8020	1	Bearing-Crankshaft
*	57-8030	1	.010" Undersize
*	57-9360	1	.002" Undersize
*	57-9800	1	.020" Undersize
*	59-0010	1	.030" Undersize
53	59-0750	2	Pin Align
54	57-8480	1	Pump-Oil
55	82-1340	2	Washer
56	82-1370	2	Screw-Hex Hd
57	71-6290	1	Kit-Gasket Complete
58	57-8460	1	Kit-Gasket
59	57-8000	2	Bearing-Camshaft
60	NN10274	1	Switch-High Temp
61	NN10924	1	Washer- Lock

*Not Illustrated

Wire Harness

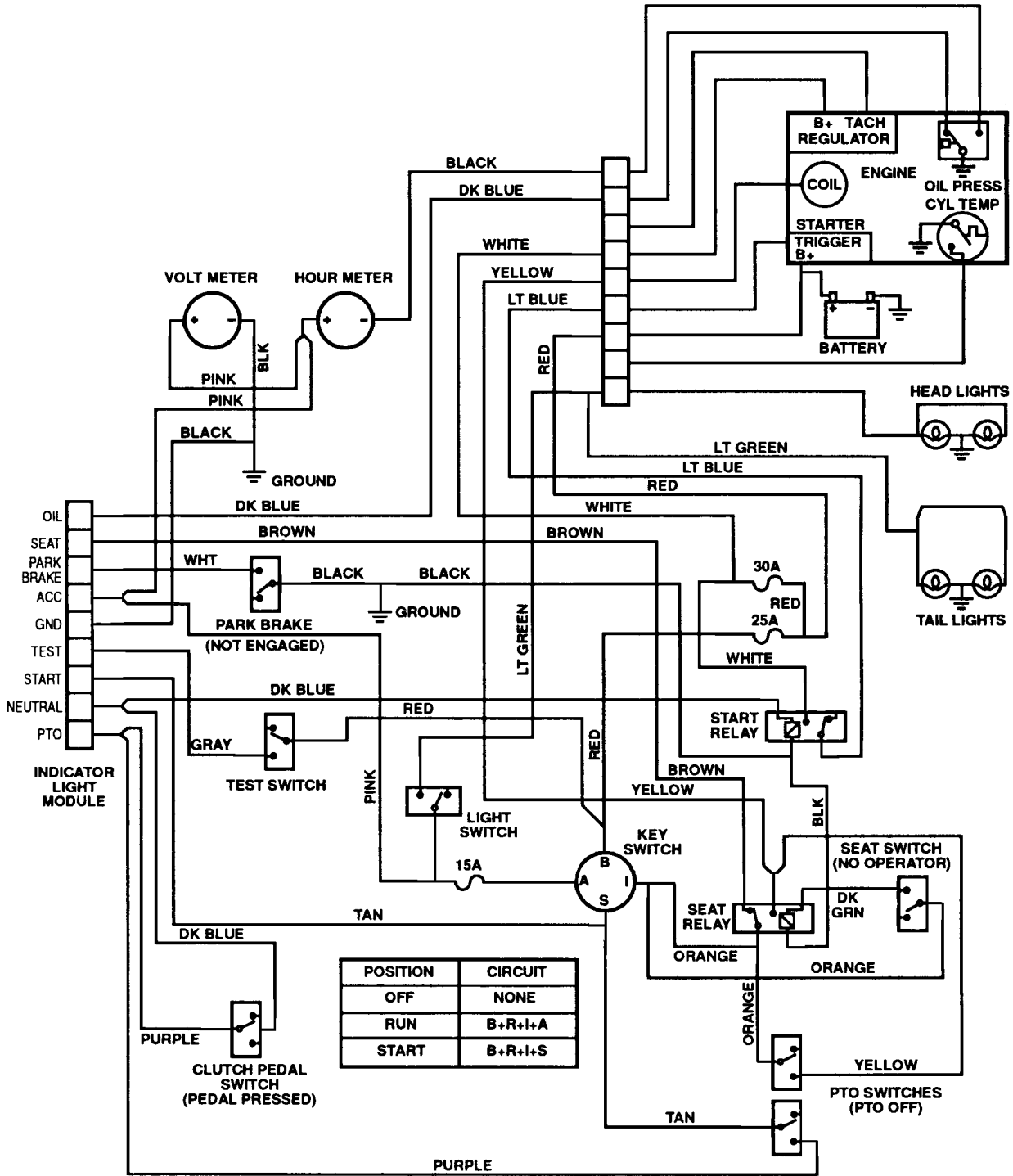

Toro Part Number Index

Part No.	Page No.	Ref. No.	Qty.	Description
1121	5	9	1	Key
1239	11	17	1	Set Screw
1243	17	28	1	Plug Cup
1278	2	9	3	Washer-Shim
1278	6	27	1	Washer-Shim
1278	12	14	4	Washer-Shim
1481	2	7	2	Fitting-Grease
1504	17	20:1	2	Bushing Bronze
1516	17	23:1	1	Bushing
1518	18	26:1	2	Needle Bearing
1518	18	29:1	2	Needle Bearing
1523	17	17	1	Needle Bearing
1529	17	29	1	Bearing-Needle
1532	17	7	2	Bearing-Needle
1542	18	34	1	Needle Bearing.
1644	13	7	1	ASM-Drawbar Hitch
2844	11	12	1	Washer-Fit
3023	7	27	3	Clip
3503	18	17	2	Shift Fork
3517	18	21	3	Ball-Detent
3527	17	19	1	Gear Cluster Shaft
3577	11	21	1	Dust Cover
3624	5	12	1	Spring-Compression
3765	9	8	1	Washer-Shim
3909	17	24	1	Differential Pin
3912	17	12	1	Gasket Transmission
3915	17	11	2	Dowel Pin
4204	17	23	1	ASM-Reverse Idler Gear
5108	12	3:3	2	Valve-Tire Tubeless
5173	18	28	1	Gear-Hi And 2nd
5174	18	27	1	Gear-Low And Reverse
5175	18	26	1	ASM Gear
5210	2	17	14	Washer-Shim
5210	12	15	2	Washer-Shim
5280	5	22	1	Knob-Height Control
5614	17	26	1	Shift Pin
5615	18	14	1	Shift Rail
5616	18	15	1	Shift Rail Rear
5618	2	30	1	Ring-Retaining
5618	13	11	2	Ring-Retaining
5638	2	27	1	Axle-Front
5666	9	4	1	Bushing-Nyliner
5979	1	17	2	Bushing-Nyliner
5983	9	6	1	Bushing
6216	2	26	1	Pin
6229	5	29	1	Bearing
6397	2	8	1	Bearing-Bronze
6472	2	1	1	Bearing-Flanged
6658	8	13	1	Race-Bearing
6659	8	12	2	Retainer
6662	8	16	1	Bearing-Needle
6663	8	15	1	Seal-Oil
6739	5	36	1	Trunnion
6820	6	8	1	Grip
7201	18	31	1	Input Shaft
7204	18	29	1	ASM Gear
7205	18	56	1	Sliding Gear
7206	18	23	1	Reduction Gear
7207	18	22	2	Needle Bearing
7208	18	14	1	Shaft Reduction Gear
7209	17	19:	1	Fork ASM Shift
7213	18	18	1	Bolt Detent

*Not Illustrated

Toro Part Number Index (cont.)

Part No.	Page No.	Ref. No.	Qty.	Description
7214	18	24	1	ASM Shift Lever
7215	18	24:1	1	Shift Lever
7216	18	24:2	1	Shaft Shift Lever
7269	17	20	1	ASM Cluster Gear
7418	18	32	1	Washer
7456	4	10	4	Clamp
7466	8	9	1	Pulley–Engine
7879	6	1	2	Bushing
7896	2	12	1	Washer–Bowed
7896	6	24	1	Washer–Bowed
8130	5	13	1	Retainer–Spring
8616	13	20	2	Spring
8830	5	38	4	Retainer–”j”
8830	10	13	2	Retainer–”j”
8830	13	28	1	Retainer–”j”
8830	15	11	1	Retainer–”j”
8830	16	21	1	Retainer–”j”
9038	13	12	1	Grip
9416	17	8	2	Bearing
9593	11	10	1	Band–Brake
9598	11	9	1	Plate–Stop
100441	17	15	1	Seal–Oil
100442	18	35	1	Oil Seal
100443	17	4	4	Oil Seal
101017	13	15	1	Lock–Hitch
101161	6	19	1	Trunion
101623	18	10	8	Pinion Gear 11t
101625	18	9:9	1	Pinion Shaft
101626	18	9:9	1	Gear–44t
101707	13	23	1	Lock–Attachment
101711	13	25	1	Plate–Front Hitch
101750	13	19	1	Rod–Latch Pivot
101751	13	27	1	Rod–Lock
101847	11	4	1	Dipstick
101850	1	15	1	Rod–Hood Stop
101889	18	5	2	Axle Diff Gear
102025	6	10	1	Spacer
102644	13	3	2	Plate–Hitch
102703	11	5	1	Trans Nipple
102809	6	7	1	Nut–Hex Lk
102872	8	2	1	Shaft–PTO
102881	1	3	2	Headlamp
102974	18	9	1	Assy–Gear (Press)
103125	9	7	1	Spring–Extension
103347	6	21	1	Rod–Clutch
103478	8	7	1	Housing–Clutch
103480	3	25	1	Switch–Interlock
103543	6	5	1	ASM–Brake Bellcrank
103628	6	6	1	Spring–Extension
104859	9	16	1	Spacer–Link
105061	18	8	1	Gear Diff Bull 43t
105202	7	30	2	Base–Light
105260	17	82	0.02	Anti Rust Lubricant
105269	13	5	1	Pin–Drawbar Hitch
105316	5	10	2	Cap–Rod
105316	13	14	2	Cap–Rod
105453	8	10	1	Key–Sq
105503	7	21	2	Bushing
105524	7	20	2	Bracket–Pivot
105763	17	1	2	Hub–Wheel
105797	1	18	2	Ring–Ext Ret
105797	13	18	8	Ring–Ext Ret

*Not Illustrated

Toro Part Number Index (cont.)

Part No.	Page No.	Ref. No.	Qty.	Description
105842	14	5	1	Battery
105875	17	6	2	Axle-Rear
105876	18	6	2	Snap Ring
105896	6	20	1	Arm-Clutch Rod
105900	6	13	1	Rod-Brake Rear
106030	17	27	2	Spring-Shift Stop
106165	11	19	1	Pulley Trans
106234	15	1	1	ASM-Tank
106236	15	18	1	Support-Fuel Tank RH
106250	3	27	1	Cover-Dust
106257	5	18	1	Rod-Latch
106258	5	23	1	Sleeve
106269	5	3	2	Bearing-Flange
106345	5	25	1	Casting-Lift Lever
106352	4	13	1	Guard-Lower Belt
106411	5	6	1	ASM-Lift Hgt Cont Bkt
106417	6	16	1	ASM-Rod
106451	6	9	1	ASM-Parking Brake
106522	5	35	1	Chain-Lift
106634	13	8	1	Pin-Tool
106695	8	20	1	Ring-Push On
106719	11	11	1	Drum-Brake
106948	14	8	1	Tray-Battery
107069	3	19	4	Nut-Speed
107069	4	5	6	Nut-Speed
107374	18	3	4	Washer
107677	6	12	1	Spring-Extension
107939	6	15	A/R	Belt-8 Sp Drive
107951	3	28	1	Bracket-Fender Front
108457	4	14	1	Nut-Push On
108464	15	12	1	Support-Fuel Tank LH
108563	5	16	1	ASM-Lift Lever
108565	5	8	1	Shaft-Lift Lever
108758	11	3	1	Knob
108881	18	11	4	Nut-Hex
109045	7	30:1	2	Lamp-Wedge
109189	2	16	1	Bearing-Flange
109262	2	13	2	Washer
109459	1	5	2	Clamp-Headlight
109494	1	2	1	Bezel-RH Headlight
109495	1	1	1	Bezel-LH Headlight
109553	14	2	1	Boot-Battery Cable
109554	16	18	1	Bracket-Belt Guard
109842	8	5	1	Bearing-Ball
109989	7	6	4	Spacer
110234	11	13	1	Screw
110653	5	26	1	Rod-Height Control
110656	9	19	1	Trunnion
110665	9	22	A/R	ASM-Bracket
110669	9	17	1	Plate-PTO
110725	11	2	1	ASM-Rod
110727	11	23	1	ASM Shift Rod
111052	9	23	1	Rod-PTO Clutch
111071	7	12	2	Bumper-Rubber
111096	18	29	1	Gear
111099	18	26	1	Gear
111196	18	4	2	End Cap-Differential
111198	17	13	1	Case Trans LH
111199	18	2	2	Bearing Ball
111200	17	10	1	Case Trans RH
111271	3	13	1	Console
111314	8	27	1	ASM-Pin

*Not Illustrated

Toro Part Number Index (cont.)

Part No.	Page No.	Ref. No.	Qty.	Description
111332	3	17	1	Switch–Interlock
111332	16	4	2	Switch–Interlock
111383	6	23	2	Collar W/Set Screw
111386	3	5	1	Plate–Shift Pattern
111392	3	16	1	Retainer–Offset”j”
111510	3	38	1	Decal–Parking Brake
111516	12	3:1	2	Wheel
111534	3	32	1	Decal–Shift Pattern
111642	16	3	2	Barrier–Switch
111757	1	7	1	Edging
111926	3	36	1	Decal–Elec System
111951	12	12	2	Cap–Hub
111952	12	13	2	Washer–Hub Cap
111960	3	33	1	Decal–PTO Clutch
112168	3	35	1	Decal–Lift
112358	1	8	1	ASM–Hood & Grill
112415	3	7	1	Stop–PTO
112506	3	14	1	Bracket
112564	7	32	2	Lens–Light
113010	14	10	1	Hold Down
113107	8	26	1	Clevis
113108	8	1	1	Rod–PTO Housing
113381	2	32	1	Spindle
113382	2	31	1	Spindle
113443	2	14	1	Tube–Steering Shaft
113445	5	31	1	ASM–Lift Bar
113853	9	13	1	ASM–Eng PTO Bkt
113925	14	1	1	Cable–Batt.
113935	4	6	1	Cover–Side LH
113969	14	9	2	Hook–Retainer
114052	1	4	1	Wire Harness
114210	14	6	1	Cable–Batt.
114215	10	20	1	ASM–Exh Cover Front
114216	10	6	1	ASM–Exh Cover Rear
114263	7	23	2	Spring–Seat
114264	7	7	1	Adjuster–Seat
114265	7	5	1	Slide–Seat
114343	7	18	1	Spring–Gas
114344	7	16	2	Spacer
114345	7	17	1	Bracket–Gas Spring
114636	10	8	1	Nipple
114720	14	7	1	Tube–Battery Drain
114763	10	10	1	Nipple
114764	10	9	1	Elbow
114881	8	8	A/R	ASM–PTO Clutch Plate
114888	10	1	6	Screw
115411	16	2	1	Bracket–Switch
116000	4	8	6	Screw–CARR
116397	16	17	2	Relay
116471	10	5	1	Muffler
116609	10	14	1	Plate–Engine
116636	17	19	1	ASM Shift Fork
116744	12	3:2	2	Tire
116745	1	19	1	Rod–Grill Pivot
116746	1	20	1	Bracket–Grill RH
116747	1	13	1	Bracket–Grill LH
117343	3	11	2	Latch–Hood
117344	1	10	2	Handle–Latch
117371	3	21	4	Screw–CARR
117431	3	12	4	Poprivet
117432	1	9	4	Poprivet
117930	13	17	1	ASM–Latch

*Not Illustrated

Toro Part Number Index (cont.)

Part No.	Page No.	Ref. No.	Qty.	Description
118280	16	11	1	Bracket-Fuse Holder
118530	10	29	1	Name Plate-Toro Logo
118530	20	19	1	Name Plate-Toro Logo
118540	10	30	1	Decal-Power Plus 16
119200	3	37	1	Decal-Lower Dash
120930	16	9:1	1	Fuse Holder
201256	28	21	1	Link-Governor Control
201270	28	15	1	Washer
201327	28	25	1	Screw-Self TAP Flg Hd
518211	4	4	A/R	Bumper-Rubber
519337	15	16	1	Clip-
910865	7	3	4	Screw
911423	18	1	4	Bolt-Hex
920248	6	4	2	Washer-Nylon
933148	5	17	1	Pin-Spirol
933156	18	16	2	Pin-Hd Spirol
933184	11	22	1	Pin-Spirol
933190	6	29	1	Pin-Spring .
933274	8	25	1	Pin-Spirol .
937089	18	33	1	Key-Woodruff
937108	17	5	2	Woodruff Key
937221	11	18	1	Key-Woodruff
950154	31	6	2	Clamp-Corbin
9080026	8	14	4	Screw-Lock
9104784	16	5	2	Screw
9107622	3	9	2	Screw Phcr
9107944	16	8	2	Screw-Phcr
9108372	3	1	6	Screw-Phcr
9108372	4	7	2	Screw-Phcr
9109482	3	6	2	Screw-Phcr
9151126	3	22	4	Nut-HH
9157324	3	18	2	Nut-Lk
9157324	16	1	2	Nut-Lk
9157404	16	12	2	Nut
9159604	3	15	2	Nut-Hex
9201504	3	10	2	Washer-Lock
9202254	6	28	1	Washer-Special
9266714	1	6	2	Screw-HWHTF
9266714	16	6	1	Screw-HWHTF
9266944	3	8	11	Screw-HH
9266944	4	15	1	Screw-HH
9266944	5	7	1	Screw-HH
9266944	6	17	1	Screw-HH
9266944	16	20	5	Screw-HH
9266964	5	21	2	Screw-HH
9266974	7	19	4	Screw-HH
9266974	15	8	2	Screw-HH
9335054	5	32	2	Hairpin
9335054	6	3	1	Hairpin
9335054	9	21	1	Hairpin
9335054	13	10	1	Hairpin
9335064	8	23	1	Hairpin
9335074	5	19	2	Cotter-Hairpin
9601524	16	13	2	Screw
9791204	13	6	2	Spacer
12-3270	10	4	3	Screw-HH
Nn10032	22	9	1	Camshaft (216)
Nn10048	31	9	1	Clamp
Nn10082	33	8	8	Lock-Valve Spring
Nn10125	33	43	2	Rod W/Bolts & Nuts STD
Nn10126	33	43	2	Rod W/Bolts & Nut .010"
Nn10127	33	43	2	Rod W/Bolts & Nut .020"

*Not Illustrated

Toro Part Number Index (cont.)

Part No.	Page No.	Ref. No.	Qty.	Description
Nn10128	33	43	2	Rod W/Bolts & Nut .030"
Nn10143	24	7	1	Filter–Oil
Nn10159	23	13	1	Cap–Indicator Oil Fill
Nn10176	27	2	1	Wrapper–Element
Nn10187	27	17	1	Tube–Air Intake
Nn10190	27	19	1	Gasket
Nn10211	31	8	1	Cap–Fuel Fitting
Nn10253	26	9	1	Cable–Spark Plug 9"
Nn10254	26	9	1	Cable–Spark Plug 18.5"
Nn10302	31	4	1	Line–Fuel 7"
Nn10306	29	18	1	Hose–Fuel 30"
Nn10362	29	4	1	Washer–Flat
Nn10370	33	19	2	Screw–Cap Hex Hd
Nn10373	24	4	2	Screw–Cap Hex Hd
Nn10375	29	12	4	Screw–Hex Hd
Nn10379	23	7	4	Screw–Cap Hex Hd
Nn10390	27	13	1	Screw–Hex Washer Hd
Nn10394	25	17	2	Screw–Hex Washer Hd
Nn10403	28	12	1	Screw–Self TAP Flg Hd
Nn10448	23	11	1	Tube–Oil Fill
Nn10545	25	25	4	Screw–Hex Hd
Nn10545	26	12	1	Screw–Hex Hd
Nn10545	29	15	2	Screw–Hex Hd
Nn10769	20	17	1	Housing–Blower
Nn10774	27	1	1	Element–Air Cleaner
Nn10790	31	3	1	Line–Fuel 12"
Nn10821	33	21	1	Cover–Valve
Nn10825	25	27	1	Kit–Gearcase
Nn10826	25	3	1	Shaft & Arm Governor
Nn10830	30	7	1	Plug–Cap
Nn10832	20	22	1	Bracket–Governor Adjust
Nn10850	33	1	1	Block–Cylinder (Short)
Nn10853	22	11	1	Crankshaft
Nn10894	24	9	1	Drain–Oil Filter
Nn10929	19	12	1	Kit–Mounting Bracket
Nn10930	19	9	1	Cap–Starter Solenoid
Nn10932	28	13	1	Spring–Governor
38–1420	7	26	1	Switch–Seat
55–3570	15	7	1	ASM–Cap
57–8000	33	59	2	Bearing–Camshaft
57–8010	33	27	1	Gasket–Bearing Plate
57–8020	33	52	1	Bearing–Crankshaft
57–8030	33		1	.010" Undersize
57–8050	33	29	1	Bearing–Crankshaft Rear
57–8060	33		1	.010" Undersize
57–8060	33		1	.010" Undersize
57–8090	23	5	1	Gasket–Base
57–8130	22	12	1	Gear–Crankshaft
57–8140	22	13	1	Washer–Gear
57–8150	21	1	1	Screw–Cap Hex Hd
57–8160	33	35	2	Washer–Thrust
57–8170	33	28	A/R	Shim–Crankshaft .005"
57–8180	21	6	1	Gear–Ring
57–8210	22	5	1	Gear–Camshaft
57–8230	22	6	1	Washer–Thrust
57–8280	33	18	2	Gasket–Cover
57–8330	33	38	2	Gasket–Head
57–8410	33	44	4	Bolt–Connecting Rod
57–8450	33	9	4	Tappet–Valve STD
57–8460	33	58	1	Kit–Gasket
57–8470	33	3	1	Plunger–Bypass Valve
57–8480	33	54	1	Pump–Oil

*Not Illustrated

Toro Part Number Index (cont.)

Part No.	Page No.	Ref. No.	Qty.	Description
57-8490	23	4	1	Cup-Intake
57-9080	31	5	1	Pump-Fuel
57-9090	22	1	1	Ring-Retaining
57-9100	28	8	1	Spring-Governor
57-9120	28	9	1	Bushing-Control Arm
57-9120	28	16	1	Bushing-Control Arm
57-9130	22	2	1	Hub-Governor Cup
57-9170	30	9	1	Swivel-Choke Lever
57-9180	30	3	1	Link-Choke
57-9190	28	2	2	Clamp-Cable
57-9190	30	4	1	Clamp-Cable
57-9210	10	21	2	Gasket-Manifold
57-9340	26	8	2	Plug-Spark
57-9360	33		1	.002" Undersize
57-9430	25	12	1	Regulator-Voltage 20 Amp
57-9550	25	21	1	Clamp-Vacuum Port Cap
57-9570	25	5	1	Seal-Oil
57-9580	25	26	1	Seal-Oil
57-9590	33	31	1	Seal-Oil
57-9610	23	12	1	O Ring-Cap
57-9620	29	5	1	O Ring
57-9630	25	7	1	Bearing-Ball Gov Shaft
57-9640	22	4	1	Ball-Governor
57-9650	25	6	1	Bearing-Governor Shaft
57-9660	22	8	1	Key-Woodruff
57-9660	22	15	1	Key-Woodruff
57-9690	33	25	1	Plug-Welch
57-9700	29	6	1	Clip-Retaining
57-9710	22	14	1	Ring-Retaining
57-9720	33	48	4	Ring-Retaining
57-9730	25	4	1	Clip-Retaining
57-9730	29	9	1	Clip-Retaining
57-9740	33	20	2	Washer-Flat
57-9750	24	3	2	Washer-Flat
57-9750	25	24	5	Washer-Flat
57-9760	33	2	1	Washer-Flat
57-9770	19	3	2	Washer-Flat
57-9770	33	40	18	Washer-Flat
57-9790	33	47	4	Nut
57-9800	33		1	.020" Undersize
59-0010	33		1	.030" Undersize
59-0020	33		1	.002" Undersize
59-0030	33		1	.020" Undersize
59-0040	33		1	.030" Undersize
59-0050	33	36	2	Insert-Valve Seat Intake
59-0080	33		2	.010" Oversize
59-0100	33	46	2	Insert-Valve Seat Exh
59-0110	33		2	.002" Oversize
59-0120	33		2	.005" Oversize
59-0130	33		2	.010" Oversize
59-0140	33		2	.025" Oversize
59-0180	33	39	1	Head-Cylinder RH
59-0260	33		4	.002" Oversize
59-0280	33	4	1	Spring-Bypass Valve
59-0290	33	51	1	Tube-Oil
59-0360	25	23	1	Tube-Vacuum Port
59-0370	25	22	1	Cap-Vacuum Port
59-0400	22	7	1	Pin-Center
59-0420	25	2	1	Yoke-Governor
59-0430	28	5	1	Spring-Idle Setting
59-0450	22	3	1	Cup-Governor
59-0470	30	1	1	Bracket-Choke Cable

*Not Illustrated

Toro Part Number Index (cont.)

Part No.	Page No.	Ref. No.	Qty.	Description
59-0580	20	3	1	Clamp-Wire
59-0590	25	18	2	Terminal-Stator Leads
59-0640	24	5	1	Elbow-Street 45 Degree
59-0720	28	14	1	Pin-Cotter
59-0720	30	10	1	Pin-Cotter
59-0730	33	26	4	Pin-Drive
59-0740	25	9	1	Pin-Dowel
59-0750	33	53	2	Pin Align
59-0790	25	29	1	Stud-Gear Cover
59-0810	21	3	1	Washer-Flat
59-0820	20	16	4	Washer-Flat
59-0820	33	22	1	Washer-Flat
59-0830	20	5	6	Washer-Flat
59-0830	28	4	2	Washer-Flat
59-0830	28	20	1	Washer-Flat
59-0850	30	12	1	Washer-Flat
59-0880	33	32	5	Scew-Cap Flg Hd
59-0900	33	41	18	Screw-Cap Hex Hd
59-0910	33	5	1	Screw-Cap Hex Hd
59-0950	25	1	2	Screw-Mach Pan Hd
59-0970	20	6	2	Screw TAP Flg Hd
59-0980	20	4	2	Screw TAP Washer Hd
59-1000	28	26	3	Screw
59-1030	28	6	1	Screw-Tapping Hex Hd
59-1050	31	7	2	Screw St Pan Hd
59-1080	20	9	4	Screw-Cap Flg Hd
59-1080	25	11	1	Screw-Cap Flg Hd
59-1100	20	21	2	Screw-Lock Hd
59-1100	28	11	1	Screw-Lock Hd
59-1130	25	28	1	Nut-Hex
59-1180	27	14	1	Capacitor
62-2730	19	13	1	Kit-Bushing
62-2760	19	1	1	Kit-Starter Hardre
62-2770	19	7	1	Kit-Starter Shift Lever
71-5730	23	8	1	Base-Oil
71-5770	33	37	2	Valve-Intake
71-5780	33	45	2	Spring-Clutch
71-5790	33	6	4	Spring-Valve
71-5800	33	7	4	Washer-Valve Spring
71-5810	33		1	Head-Cylinder LH
71-5830	33	17	4	Cap-Valve
71-5920	21	5	1	Flywheel Incl 6
71-5960	31	2	1	Filter-Fuel
71-5980	29	16	2	Gasket-Manifold
71-5990	26	1	1	Cover-Plunger
71-6000	26	7	1	Coil-Battery Ignition
71-6010	26	13	1	Rotor-Ignition
71-6040	19	2	1	Starter Incl 1-13
71-6060	26	10	1	Clip-Wire
71-6080	20	10	2	Bracket-Lift
71-6140	27	16	1	Grommer-Rubber
71-6170	23	9	1	Seal-Oil
71-6180	33	23	2	Seal-Valve
71-6190	21	7	1	Key-Flywheel
71-6220	20	7	1	Clip-Wire
71-6220	26	11	2	Clip-Wire
71-6220	29	19	1	Clip-Wire
71-6250	33	24	2	Guide-Valve
71-6260	33		2	Guide-Valve
71-6290	33	57	1	Kit-Gasket Complete
71-6310	33	49	2	Pin-Piston
71-6340	21	8	6	Spring-Compression

*Not Illustrated

Toro Part Number Index (cont.)

Part No.	Page No.	Ref. No.	Qty.	Description
71-6360	25	8	1	Gasket-Mntg
71-6380	25	14	1	Control-Ignition
71-6410	25	15	1	Insulator-Ignition
71-6430	26	5	1	Nut-Hex Flg Hd
71-6440	26	4	1	Nut-Hex Flg Hd
71-6460	26	6	2	Screw-Hex Washer Hd
72-3880	30	2	1	Screw-Cap Flg Hd
72-3890	28	17	1	Screw-Hex Hd
72-3890	30	8	1	Screw-Hex Hd
72-3900	28	1	1	Screw-Tapping Hex Hd
72-3900	30	5	1	Screw-Tapping Hex Hd
72-3930	19	8	1	Kit-Starter Solenoid
72-3940	19	6	1	Clutch-Starter
72-3950	19	5	1	Seal-Dust
78-1550	5	28	1	Lift Lever
78-2880	2	4	1	Lower Steering
78-2900	2	33	2	ASM-Tie Rod
78-2990	7	13	1	Plate-Seat Pivot
78-3010	3	23	1	Bracket-Battery Support
78-3020	16	22	1	Plate-Front
79-2470	3	34	1	Decal-Back Plate
79-3600	16	9	1	Wiring-Harness & Dia
79-4990	15	19	1	Bracket-Fender Support
79-6330	27	11	1	Housing-Air Cleaner
79-6340	27	12	1	Support-Air Cleaner
79-6360	28	3	1	Bracket-Cable
79-6390	28	23	1	Bracket-Governor Cont
79-6400	28	22	1	Bushing-Governor Cont
79-6420	28	10	1	Adapter-Governor Arm
79-6440	21	4	1	Screen-Air Inlet
79-6460	23	2	1	Bracket-Fill Tube
79-6470	24	1	1	Gasket-Adapter
79-6490	26	14	1	Gasket-Plate
79-6510	27	3	1	Spacer-Stud
79-6520	27	4	1	Spacer-Nylon
79-6580	19	4	2	Screw-Cap
82-0020	33	30	1	Plate-Bearing
82-0500	24	2	1	Adapter-Oil Filter
82-0530	33	12	1	Clamp-Tube
82-0540	33	10	1	Tube-Breather
82-0550	33	15	1	Cap & Valve-Breather
82-0560	33	14	2	Screen-Tube
82-0570	33	13	1	O-Ring-Cap
82-0620	20	18	1	Guard-Stationary
82-0680	24	8	1	Filter-Gasket Oil
82-0850	29	11	1	Gasket-Carb/Manifold
82-1000	25	13	2	Body-Term Conn Kit
82-1070	29	3	1	Fitting-Barbed
82-1080	29	2	2	Clamp-Hose .50" Dia
82-1080	31	1	6	Clamp-Hose .50" Dia
82-1090	29	2	1	Clamp-Hose .44" Dia
82-1120	29	1	1	Hose-Breather
82-1130	23	10	2	Plug-Square Head
82-1310	23	6	4	Washer-Flat
82-1310	33	33	5	Washer-Flat
82-1320	21	2	1	Washer-Flat
82-1340	26	2	2	Washer
82-1340	33	55	2	Washer
82-1350	29	13	6	Washer
82-1360	26	3	2	Screw-Hex Hd
82-1370	28	18	1	Screw-Hex Hd
82-1370	33	56	2	Screw-Hex Hd

*Not Illustrated

Toro Part Number Index (cont.)

Part No.	Page No.	Ref. No.	Qty.	Description
82-1480	33	16	1	Screw-TAP Round Hd
82-1500	25	20	3	Screw-Mach Hex Hd
82-1510	24	10	2	Screw-Hex Hd
82-1540	20	8	1	Bolt-Hex Hd
82-1540	29	17	1	Bolt-Hex Hd
82-1550	27	9	2	Screw-Hex Washer Hd
82-1560	23	1	1	Screw
82-1590	20	20	4	Screw-PH Torx
82-1600	20	2	2	Screw-Cap Hex Flg Hd
82-1620	28	19	1	Washer-Lock
82-1660	25	16	2	Washer-Lock
82-1670	27	5	1	Knob
82-1690	27	15	1	Nut-Hex Washer Hd
82-1700	23	3	1	Nut-Speed
82-1800	33	42	2	Piston STD INC 48-49
83-2710	11	1	1	Knob
83-2720	12	2	10	Bolt-Lug
83-2890	17	16	1	Bearing-Needle
83-3530	17	21	1	Shaft-Cluster
83-6520	13	16	1	Rod-Lock
88-2170	3	24	1	Bracket-Belt
88-2710	2	5	1	Support-Lower Steering
88-3870	2	21:1	1	Cover-Steering Wheel
92-0902	33		2	.010" Oversize
92-0903	33		2	.020" Oversize
92-0904	33		2	.030" Oversize
92-0905	33	50	2	Kit-Ring Piston STD
92-0906	33		2	.005" Oversize
92-0907	33		2	.010" Oversize
92-0908	33		2	.020" Oversize
92-0909	33		2	.030" Oversize
92-0911	22	10	1	Sleeve-Bearing
92-0915	27	10	2	Screw-Mach Hex Hd
92-0916	30	6	1	Screw-Shoulder
92-0919	29	7	1	Rod-Governor Control
92-0920	20	1	1	Housing-Cylinder Air LH
92-0921	20	12	1	Housing-Cylinder Air RH
92-0922	28	7	1	Arm-Governor Control
92-0967	25	19	1	Stator
92-1525	3	20	1	Hoodstand
92-4987	2	19	1	Steering Shaft
92-5935	19	10	1	Nut
92-6649	17	23:	1	Gear-Spur
92-6710	5	11	1	Grip-Handle
92-8708	11	6	1	Trans ASM 8 Pin 8 Spd
92-8946	3	31	1	Decal-Danger
92-9513	15	20	1	Line-Fuel 47"
92-9826	1	24	1	Decal-Front Hood
92-9837	1	26	1	Decal-Danger
93-1613	13	22	1	Latch
93-7339	3	34	A/R	Decal-Back Plate
93-9800	12	10	2	ASM-Wheel & Tire
94-1803	10	3	1	Baffle-Deflector
94-1806	29		1	Decal-Ident
94-1809	3	2	1	Plate-Hoodstand
94-1810	10	7	1	Engine-Onan
94-1834	11	24	1	Decal-Unidrive
94-1840	27	6	1	Cover-Cleaner
94-1841	29	10	1	Kit-Carburetor (216)
94-1842	29	10	1	Jet-Altitude
94-1843	29		1	Kit-Repair
94-1843	29	10	1	Kit-Repair

*Not Illustrated

Toro Part Number Index (cont.)

Part No.	Page No.	Ref. No.	Qty.	Description
94-1844	29		1	Kit-Repair
94-1844	29	10	1	Kit-Repair
94-1845	24	6	1	Switch-Pressure
94-1845	24	6	1	Switch-Pressure
94-1846	29		1	Harness-Wire
94-1848	29		1	Jet-Altitude
94-3519	2	21	1	Steering Wheel 15"
94-3521	4	17	1	Footrest RH
94-3522	4	9	1	Footrest LH
94-3701	9	2	1	W.a. PTO Clutch Lever
94-3703	6	25	1	Pedal-Clutch
94-3704	8	21	1	Belt Cover-PTO
94-3709	1	23	1	Horsehead Logo
94-3710	4	1	1	Mat-Foot RH (Gear)
94-3712	4	2	1	Mat-Foot LH
94-3715-01	2	22	1	Frame W.a.
94-3719	7	8	1	Seat
94-3722-01	7	22	1	Fender
94-3725-01	4	16	1	Belt Guard (Twin)
94-3726	8	18	1	Bracket
94-3727	9	1	1	Knob
94-3729	8	28	1	Retainer-Bolt
94-3735	8	22	2	Nut-Wing
94-3737	10	2	1	Shield-Heat
94-6330	13	29	2	Decal-Attach A Matic
94-6332	1	27	1	Decal-Hood LH Top
94-6333	1	25	1	Decal-Hood RH Top
94-6340	3	30	2	Decal- Model 416-8
94-6650	8	8	1	ASM-Plate
94-6652	9	22	1	ASM-Brake
123-1417	33	11	1	Baffle-Breather Tube
140-2794	27	8	1	Cover-Element
150-2550	29	8	1	Spring-Governor Rod
153-0423	30	11	1	Lever-Choke
191-1951	19	11	1	Kit-Starter Brush
237-69	2	20	1	O-Ring
2412-98	15	21	2	Clamp-Hose
281-2	18	12	1	Plug-Pipe
281-10	18	13	1	Plug-Pipe
288-4	10	11	1	Cap-Pipe
302-5	2	28	2	Fitting-Grease
302-5	6	26	1	Fitting-Grease
321-3	11	7	2	Screw-HH
321-3	16	19	2	Screw-HH
321-4	14	3	2	Screw-HH
321-8	7	25	2	Screw-HH
322-1	2	24	1	Screw-HH
322-2	5	39	2	Screw-HH
322-2	15	15	2	Screw-HH
322-3	10	23	4	Screw-HH
322-3	15	17	4	Screw-HH
322-4	7	10	6	Screw-HH
322-5	3	3	2	Screw-HH
322-5	5	24	3	Screw-HH
322-6	5	34	1	Screw-HH
323-5	11	14	4	Screw-HH
323-6	2	2	2	Screw-HH
323-6	8	19	1	Screw-HH
323-6	9	15	2	Screw-HH
323-7	9	12	1	Screw-HH
323-7	10	12	4	Screw-HH
323-8	2	6	2	Screw-HH

*Not Illustrated

Toro Part Number Index (cont.)

Part No.	Page No.	Ref. No.	Qty.	Description
323-8	10	19	4	Screw-HH
323-9	6	14	1	Screw-HH
323-11	17	16	5	Screw
323-16	17	14	1	Screw-HH
323-44	13	1	6	Screw-HH
3217-5	11	16	1	Nut-Hex
3217-7	10	16	4	Nut-Hex
3218-1	9	9	2	Nut-Jam
3218-3	17	2	4	Nut-HJ
3229-25	1	14	4	Screw-CARR
3229-25	9	20	2	Screw-CARR
3230-1	4	12	1	Screw-CARR
3231-25	13	26	3	Screw-CARR
3235-22	15	10	2	Screw-HH Lock
3242-2	11	20	1	Screw Set-SH
3243-5	17	3	4	Screw-Set
3246-2	8	11	2	Screw-HSH Set
3247-4	33	34	2	Screw-HS
3250-31	7	31	4	Screw-Phcr
3253-2	25	10	3	Washer-Lock
3253-3	9	10	2	Washer-Lock
3253-3	11	8	2	Washer-Lock
3253-3	14	13	2	Washer-Lock
3253-4	2	25	1	Washer-Lock
3253-4	10	22	4	Washer-Lock
3253-4	15	14	2	Washer-Lock
3253-5	33	33	5	Washer-Lock
3253-21	9	14	2	Washer-Spring Lock
3253-21	10	15	4	Washer-Spring Lock
3253-21	11	15	4	Washer-Spring Lock
3254-1	7	29	4	Washer-Lk
3254-2	1	21	1	Washer-Lock Int.
3256-4	15	9	2	Washer-Flat
3256-5	5	20	1	Washer-Flt
3256-22	1	12	3	Washer-Flat
3256-22	7	15	2	Washer-Flat
3256-22	9	11	2	Washer-Flat
3256-22	14	4	4	Washer-Flat
3256-23	3	4	2	Washer-Flat
3256-23	5	5	3	Washer-Flat
3256-23	7	11	4	Washer-Flat
3256-24	6	11	2	Washer-Flat
3256-24	10	18	4	Washer-Flat
3256-25	5	33	1	Washer-Flt
3256-26	6	2	1	Washer-Flt
3256-26	13	9	1	Washer-Flt
3256-27	8	24	1	Washer-Flat
3256-62	5	2	2	Washer-Flt
3272-1	1	16	2	Pin-Cotter
3272-6	6	18	1	Pin-Cotter
3272-10	5	27	1	Pin-Cotter
3272-10	6	22	1	Pin-Cotter
3272-10	9	5	3	Pin-Cotter
3272-17	12	7	2	Pin-Cotter
3272-19	2	11	1	Pin-Cotter
3272-21	2	17	1	Pin-Cotter
3290-378	1	22	1	Tie-Cable
3290-479	4	3	16	Fastener-Panel
3296-6	2	3	4	Nut-Lock
3296-27	7	28	4	Nut-Lock
3296-29	3	26	2	Nut-Lock
3296-29	4	11	7	Nut-Lock

*Not Illustrated

Toro Part Number Index (cont.)

Part No.	Page No.	Ref. No.	Qty.	Description
3296-29	5	4	6	Nut-Lock
3296-29	7	4	6	Nut-Lock
3296-29	7	24	4	Nut-Lock
3296-29	15	13	4	Nut-Lock
3296-39	2	23	4	Nut-Lock
3296-39	5	37	1	Nut-Lock
3296-39	6	15	1	Nut-Lock
3296-39	9	18	1	Nut-Lock
3296-39	10	17	4	Nut-Lock
3296-39	13	4	6	Nut-Lock
3296-39	13	24	3	Nut-Lock
3296-39	17	9	6	Nut-Lock
3296-42	1	11	4	Nut-Lock
3296-42	7	14	2	Nut-Lock
3296-42	14	12	2	Nut-Lock
3296-42	16	10	4	Nut-Lock
32103-22	14	11	2	Nut-Wing
32120-47	5	30	1	Ring-Retaining
32120-62	8	4	1	Ring-Retain
32120-72	8	3	2	Ring-Retaining
32120-93	2	34	2	Snap Ring
32121-25	5	15	1	Pin-Roll
32121-103	5	14	1	Pin-Spring
32121-111	2	15	1	Pin-Spiral
32128-40	8	17	1	Nut-Lock
32136-5	2	10	1	Nut-Slotted
32151-11	9	3	1	Ring-Grip
32151-91	5	1	1	Ring-Retaining
505-27	17	83	0.01	Compound-Lock
541-0275	29	14	1	Manifold-Intake (216)