



Count on it.

Parts Catalog

**Left-Hand Replacement Mower
2010 and Before Groundsmaster® 4000-D
Traction Unit**

Model No. 30416—Serial No. 312000001 and Up

Ordering Replacement Parts

To order replacement parts, please supply the part number, the quantity, and the description of each part desired.

Understanding Reference Numbers

Each identified part in an illustration has a reference number. The reference number for a part also appears in the parts list, along with other information about the part.

This catalog uses two special reference number formats, one to indicate parts in a service assembly and another to indicate the quantity of a given part in an illustration.

Service Assembly Reference Numbers

Parts in service assemblies have reference numbers in the form a:b. The a represents the reference number of the entire service assembly and the b represents a sequential number unique to each part within the service assembly.

For example, a wheel assembly might be identified by reference number 6, the tire by 6:1, the valve by 6:2, and the wheel by 6:3. When you order the assembly identified by reference number 6, you receive all parts identified by reference numbers 6:1, 6:2, and 6:3. However, you may also order any part individually. Reference numbers of this type appear in illustration and in parts lists.

Reference Numbers Indicating Quantity

In an illustration, if a reference number indicates more than one part, the reference number has the form nX y. The n represents the quantity of the part, the X is the multiplication symbol, and the y represents the reference number.

For example, in an illustration, the reference number 2X 37 means that two of the parts identified by reference number 37 are indicated.

List of Abbreviations

AR: as required

ASM: assembly

BBC: blade brake control

BHTF: button head thread forming

CARR: carriage

CCW: counter clockwise

CW: clockwise

DEG: degrees

DPA: Dual Point Adjustment

ECM: electronic control module

EXT: external

FH: flat head

GA: gauge

HD: heavy-duty

HF: hex flange

HH: hex head

HHF: hex head flange

HHFTF: hex head flange thread forming

HJ: hex jam

HLH: hex lag head

HOC: height-of-cut

HSBH: hex socket button head

HSFH: hex socket flat head

HSH: hex socket head

HWH: hex washer head

HWHTF: hex washer head thread forming

HYD: hydraulic

LH: left hand

LP: Liquid Propane

NI: nylon insert

NPTF: national pipe thread fine

PFH: phillips flat head

PPH: phillips pan head

PPHTF: phillips pan head thread forming

PRH: phillips round head

PTH: phillips truss head

PTO: power-take-off

RH: right hand

ROPS: roll-over protection system

RRB: rear roller brush

SFH: slotted fillister head

SHH: slotted hex head

SHWH: slotted hex washer head

SPH: slotted pan head

SQH: square head

SRH: slotted round head

STD: standard

TAP: self tapping

TTH: torx truss head

Contents

Left Hand Deck, Idler and Skid Assembly	4
Right Hand and Left Hand Castor Arm and Wheel Assembly	6
Spindle Installation Assembly	7
Left Hand Deck Chamber and Cover Assembly	8

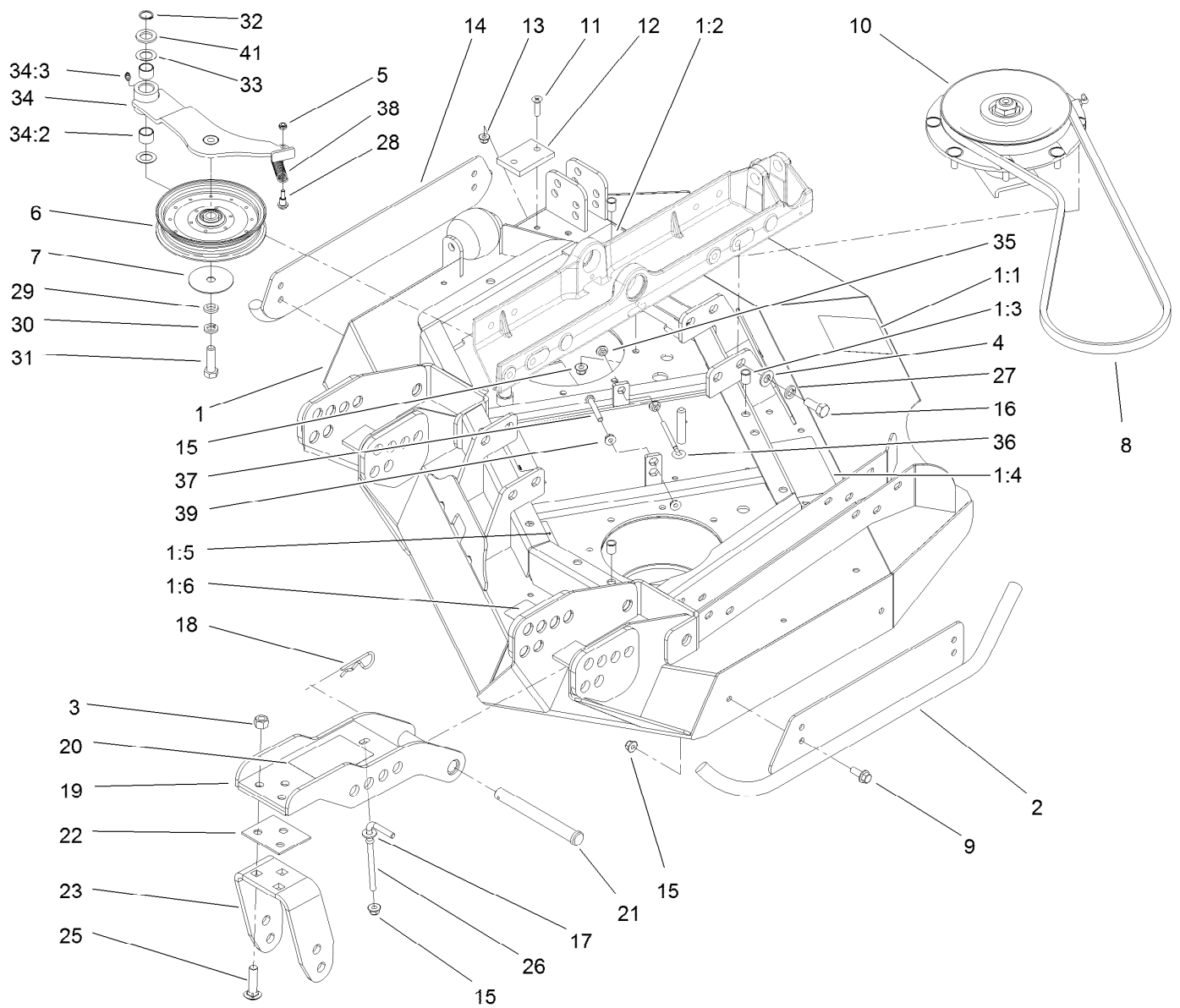

Left Hand Deck, Idler and Skid Assembly

Ref.	Part Number	Qty.	Description	Ref.	Part Number	Qty.	Description
1	110-3296	1	Left Deck ASM	16	325-5	8	Screw-HH
1:1	120-6604	1	Decal-Danger	17	3256-3	2	Washer-Flat
1:2	100-5693	1	Decal-Rear HOC, LH	18	3290-343	4	Pin-Hair
1:3	32148-9	3	Insert-Nut	19	104-7529-01	2	Castor Bracket ASM
1:4	100-5622	1	Decal-HOC	20	104-3579	1	Decal-HOC
1:5	100-6578	3	Decal-Danger	21	100-5569	4	Pin-Clevis
1:6	93-7818	1	Decal-Torque, Blade Bolt	22	104-7524	8	Shim
2	100-8125-01	1	LH Skid ASM	23	104-7525-01	2	Bracket-Fork
3	3296-45	6	Nut-Lock, NI	25	3233-4	6	Screw-CARR
4	3256-26	8	Washer-Flat	26	106-2047	2	Rod-Tension
5	3296-56	1	Nut-Lock, NI	27	3253-7	8	Washer-Lock
6	110-9596	1	Pulley-Idler	28	104-0858	1	Bolt-Shoulder
7	100-3102	1	Washer-Flat	29	9202424	1	Spacer
8	108-8076	1	V-Belt, Deck	30	3253-7	1	Washer-Lock
9	3234-42	4	Screw-HHF	31	325-7	1	Screw-HH
10	119-4776	1	Low-Driven Spindle ASM	32	32120-72	1	Ring-Snap
11	32108-103	2	Screw-FH	33	3-6498	2	Washer-Thrust
12	69-9290	1	Pad-Bumper	34	110-6128	1	Idler Arm ASM
13	104-8300	2	Nut-Flange, NI	34:2	256-76	2	Bushing
14	104-2250-01	1	Side Skid ASM	34:3	302-5	1	Fitting-Grease
15	104-8301	18	Nut-Flange, NI	35	32128-14	2	Nut-HF

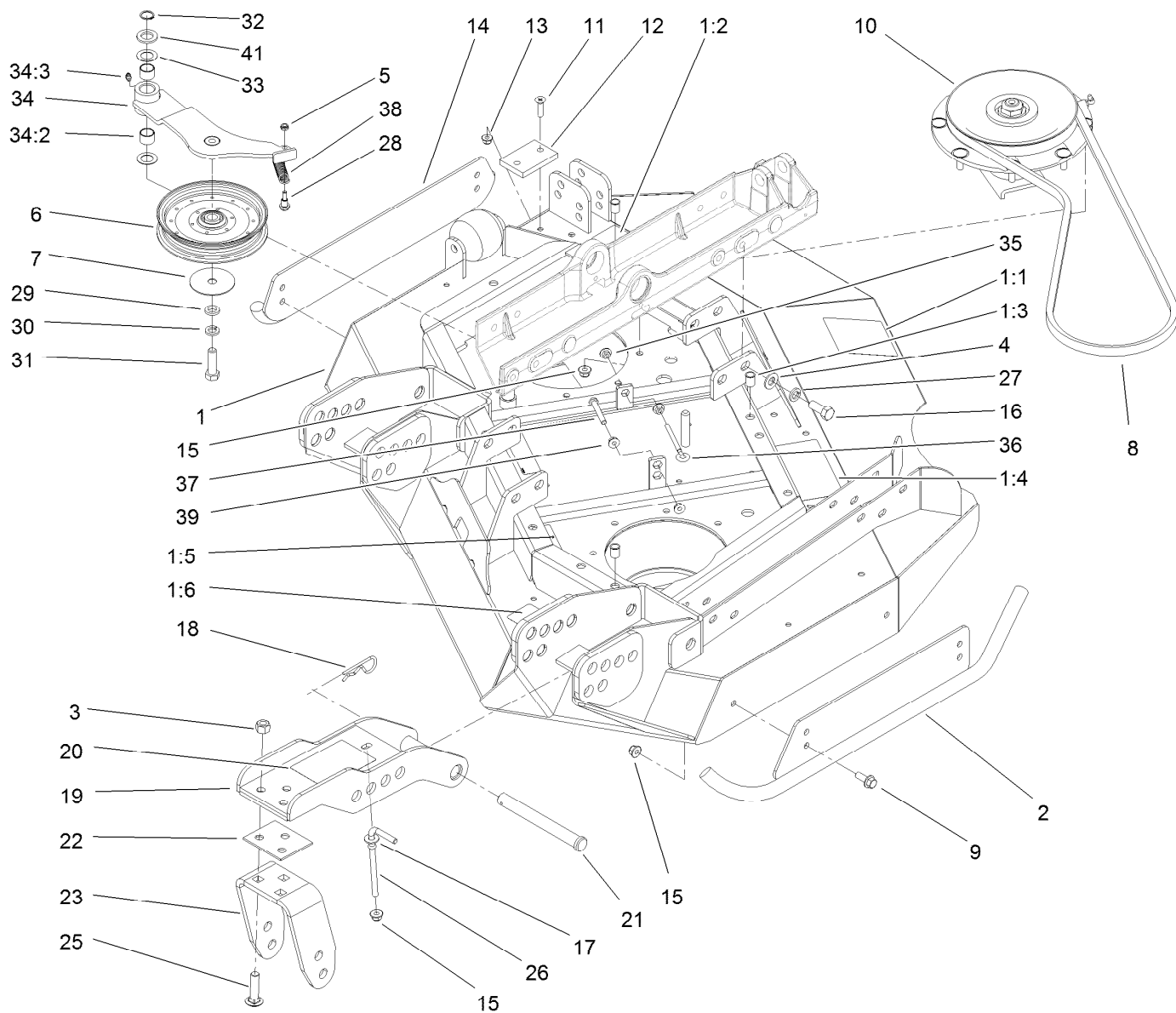

Left Hand Deck, Idler and Skid Assembly (continued)

<i>Ref.</i>	<i>Part Number</i>	<i>Qty.</i>	<i>Description</i>	<i>Ref.</i>	<i>Part Number</i>	<i>Qty.</i>	<i>Description</i>
36	68-0090	1	Screw-Adjusting	39	32128-26	2	Nut-Flange
37	9114524	1	Bolt-TAP, HH	41	70-1160	1	Washer
38	107938	1	Spring-Extension				

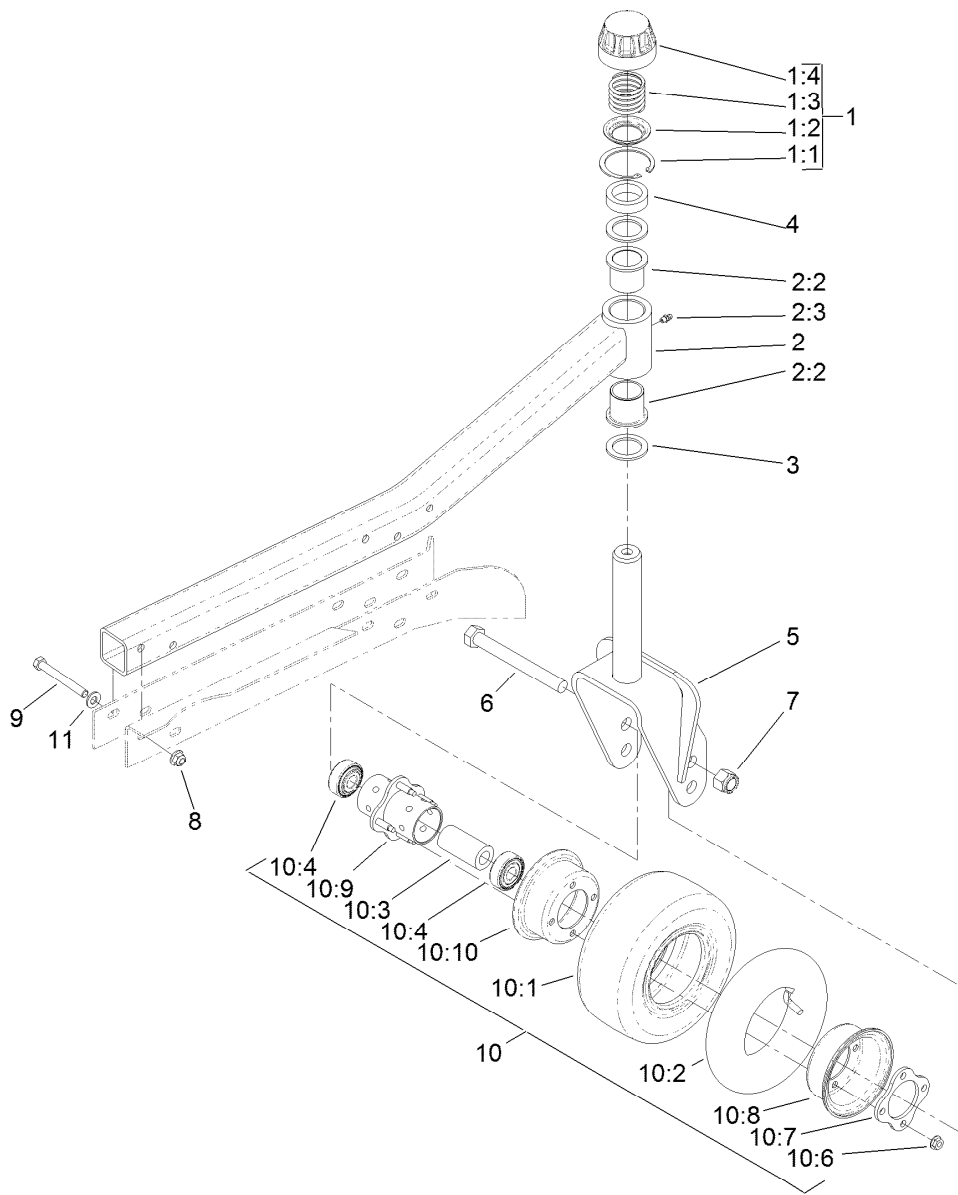

Right Hand and Left Hand Castor Arm and Wheel Assembly

Ref.	Part Number	Qty.	Description	Ref.	Part Number	Qty.	Description
1	92-9727	1	HOC Cap ASM	9	323-20	5	Screw-HH
1:1	92-5581	1	Ring-Retaining	10	93-5974	3	8 Inch Foam Filled Wheel ASM ●
1:2	92-5583	1	Washer-Cap	10	93-9938	3	8 Inch Wheel ASM
1:3	92-9726	1	Spring-Compression	10:1	93-9939	1	Tire
1:4	92-8861	1	Cap-HOC	10:2	68-8950	1	Tube-Inner (W/Valve)
2	100-8093	1	Side Castor Arm ASM	10:3	93-4241	1	Spacer-Bearing, Inner
2:2	69-6470	2	Bushing-Castor	10:4	120-3366	2	Bearing
2:3	302-5	1	Fitting-Grease	10:6	32128-16	4	Nut-HHF
3	69-6860	2	Washer-Thrust	10:7	93-4242	1	Plate
4	69-1510	5	Spacer	10:8	93-4239	1	Rim-Wheel, Half
5	104-0762-01	1	Castor Fork ASM	10:9	93-5980	1	Hub
6	327-24	3	Screw-HH	10:10	95-2741	1	Rim-Wheel, Half
7	3296-53	3	Nut-Lock, NI	11	3256-24	5	Washer-Flat
8	104-8301	5	Nut-Flange, NI				

● Optional Equipment

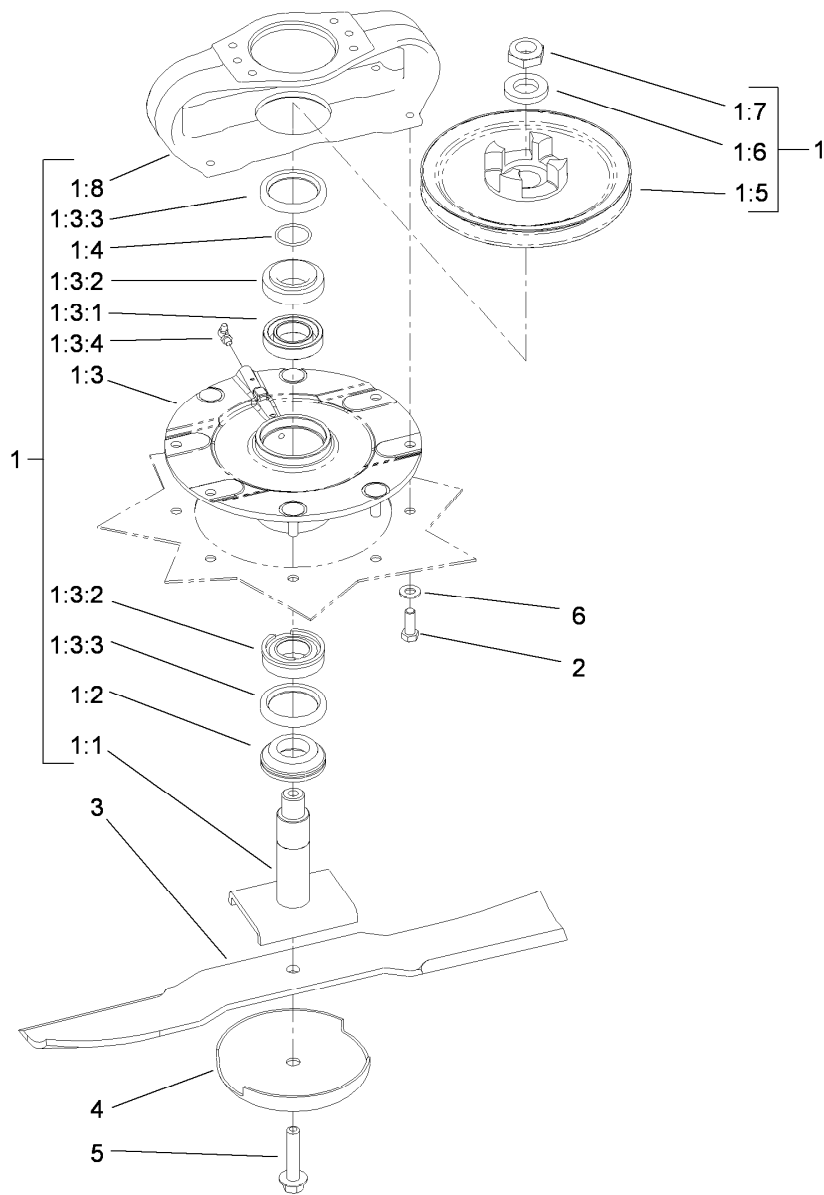

Spindle Installation Assembly

<i>Ref.</i>	<i>Part Number</i>	<i>Qty.</i>	<i>Description</i>	<i>Ref.</i>	<i>Part Number</i>	<i>Qty.</i>	<i>Description</i>
1	119-4547	1	Driving Spindle ASM	1:5	104-3545	1	Pulley-Driving
1:1	104-3554	1	Spindle Shaft ASM	1:6	104-8322	1	Washer-Hardened
1:2	69-6950	1	Spacer-Shaft, Spindle	1:7	3296-60	1	Nut-Lock, NI
1:3	119-4546	1	Spindle Housing ASM	1:8	104-3544	1	Mount-Motor, Drive
1:3:1	104-3549	1	Bearing Spacer Set	2	323-6	4	Screw-HH
1:3:2	110-8297	1	Bearing ASM	3	92-5608-03	2	Blade
1:3:3	253-154	2	Seal-Oil	4	72-9361	2	Cup-Scalp, Anti
1:3:4	302-60	1	Fitting-Grease	5	92-5816	2	Bolt-Blade
1:4	106-7159	1	O-Ring	6	3256-24	4	Washer-Flat

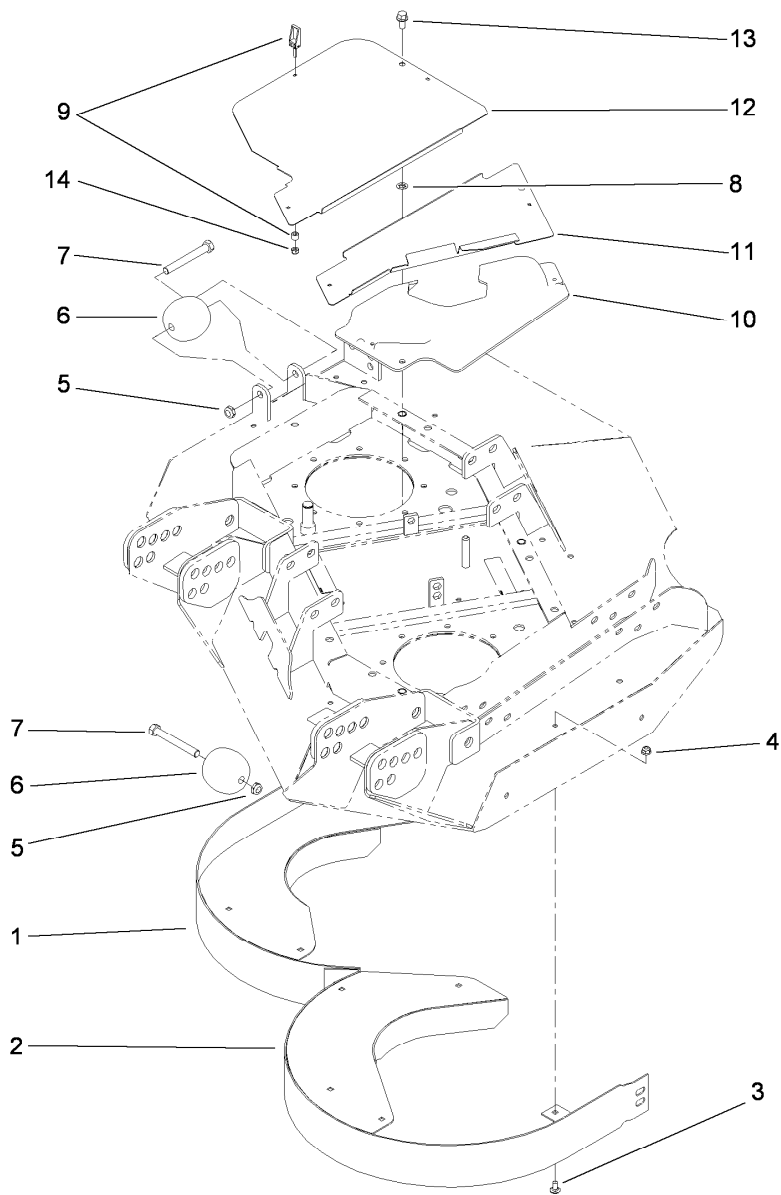

Left Hand Deck Chamber and Cover Assembly

<i>Ref.</i>	<i>Part Number</i>	<i>Qty.</i>	<i>Description</i>
1	104-2205-01	1	Inner Chamber ASM
2	104-2206-01	1	Outer Chamber ASM
3	3230-18	9	Screw-CARR
4	104-8300	9	Nut-Flange, NI
5	3296-45	2	Nut-Lock, NI
6	29-4820	2	Roller
7	325-17	2	Screw-HH
8	107-3154	3	Nut-Push
9	74-5950	7	Latch-Swell
10	100-5669	1	Cover-Motor, LH Deck
11	100-5664-03	1	Plate-Cover, LH
12	100-5667-03	1	Plate-Cover, LH Side
13	3234-1	3	Screw-HHF
14	1-804254	7	Nut-Lock, HH

Notes:

Notes:

Notes:



Count on it.