



MODEL NO. 42-3370

INSTALLATION INSTRUCTIONS

12 VOLT STARTING MOTOR KIT (FOR SNOWTHROWERS MODEL NO. 38090, 38150 & 38160)

Note: Battery and battery charger are not included in starting motor kit. Recommended battery is 12 volt, type 22FC, SAE No. 17MJIC. Recommended battery chargers are 110 volt Toro charger (26-3870) for use in U.S. and Canada, 220 volt Toro charger (26-7140) for use in Europe or a comparable 1 to 5 amp charger.

BATTERY DIMENSIONS

Length: 9.50 inches (241 MM)

Width: 6.79 inches (172 MM)

Height: 8.17 inches (207 MM)

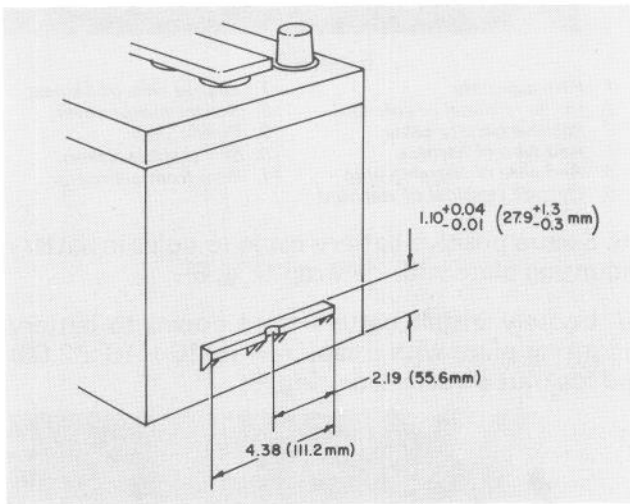

Figure 1

1. Battery hold down design

INSTALL 12 VOLT STARTING MOTOR KIT

1. Remove four self tapping screws securing rear shield to engine base and remove shield (Fig. 2).

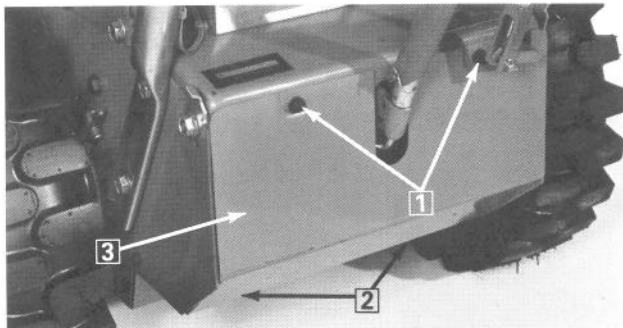

Figure 2

1. Self tapping screws
2. Self tapping screws (not shown)
3. Rear Shield

2. Remove two self tapping screws securing belt cover and remove cover (Fig. 3).

3. Remove three plated capscrews and locknuts securing side plate to engine base (Fig. 3).

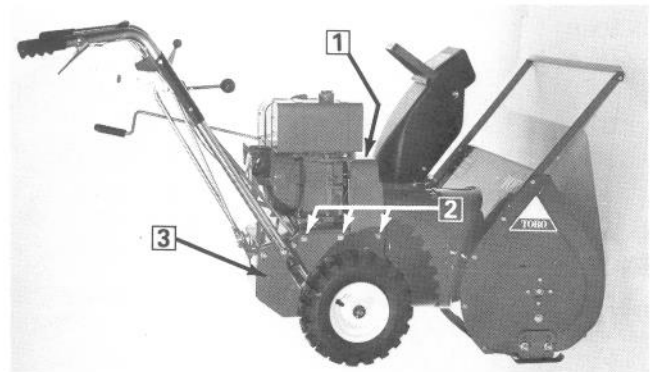

Figure 3

1. Belt cover and self tapping screws
2. Plated capscrews and locknuts
3. Side plate

4. Secure battery isolator pad and battery mounting plate to side plate and engine base using capscrews and locknuts removed in step 3. (Fig. 4).

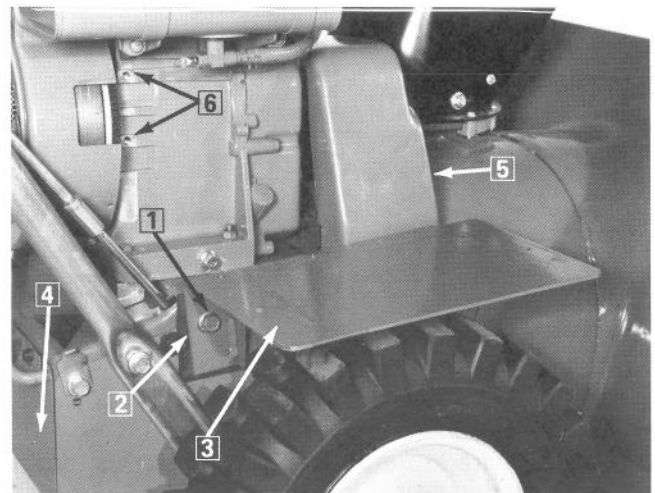

Figure 4

1. Capscrews & locknuts
2. Isolator pad
3. Battery mounting plate
4. Rear shield
5. Belt cover
6. Mounting holes for pinion cover

5. Reinstall rear shield and belt cover.
6. Remove two self tapping screws securing pinion cover (screws to be used later in assembly) and remove cover (Fig. 4).
7. Secure starter motor assembly, negative (black) battery cable, and black grounding wire of charging plug (wire with ring terminal end) with two capscrews as shown (Fig. 5).

Note: A two lead wire connector, to be used with charging plug, is provided for use with a non plug in type charger.

8. Secure solenoid mounting bracket to battery mounting bracket with two self tapping screws (Fig. 5).
9. Secure solenoid to solenoid mounting bracket with two capscrews, lockwashers, and locknuts. Make sure solenoid is positioned with small terminal positioned to the rear of the mounting bracket (Fig. 5).

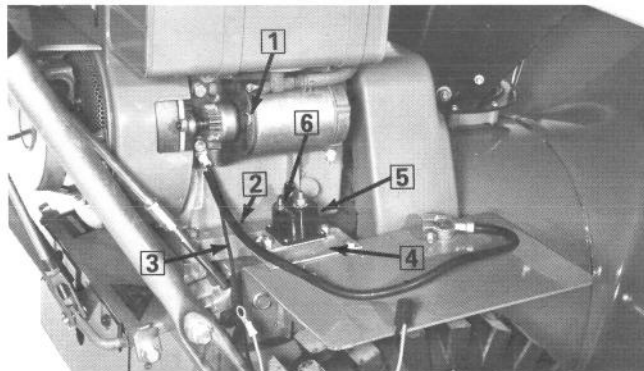

Figure 5

1. Starter motor & pinion assembly
2. Negative battery cable
3. Black grounding wire for charger
4. Solenoid mounting bracket
5. Solenoid
6. Small terminal positioned to rear

10. Remove two self tapping screws securing bottom of fuel tank bracket to engine (screws to be used later in assembly)(Fig. 6).

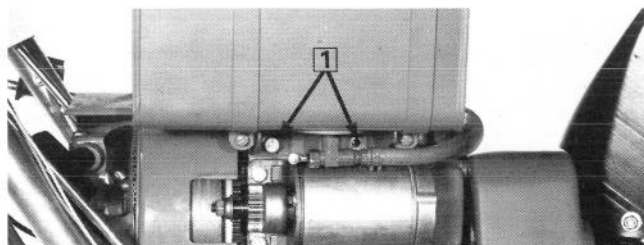

Figure 6

1. Screws securing bottom of fuel tank

11. Install wire assembly connecting starter motor to inside terminal of solenoid (Fig. 7).

12. Connect positive battery cable, red wire of wire harness and red wire of charging plug to outside terminal of solenoid (Fig. 7).

Note: On model #38160, secure wire from alternator to outside terminal of solenoid.

13. Connect orange wire of wire harness to small terminal on solenoid (Fig. 7).

14. Slide starter motor cover into mounting position behind bottom of fuel tank bracket and secure with two self tapping screws previously securing fuel tank bracket (Fig. 7).

15. Install new pinion shield with self tapping screws removed in step 6.

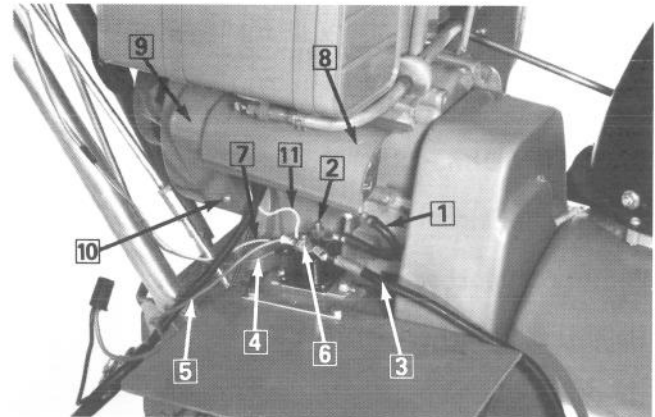

Figure 7

1. Wire assembly
2. Inside terminal of solenoid
3. Positive battery cable
4. Red wire of harness
5. Red wire of charging plug
6. Outside terminal of solenoid
7. Orange wire of harness
8. Starter motor cover
9. Pinion shield
10. Self tapping screws
11. Wire from alternator

16. Secure positive battery cable to holes in battery mounting plate with tie wrap (Fig. 8).

17. Loosely install battery hold downs to battery mounting plate with a capscrew (5/16 x 18 x 2.00) and locknut on each side (Fig. 8).

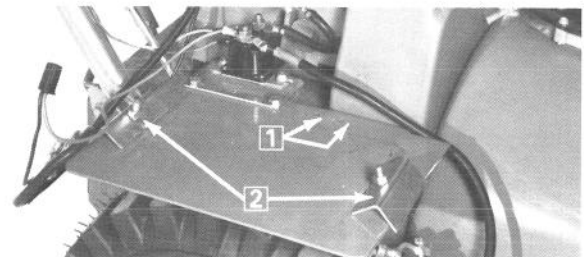

Figure 8

1. Secure positive battery cable here
2. Battery hold downs

18. Disconnect and remove on-off key switch from control panel.

19. Secure decal on control panel around hole for switch (Fig. 9).

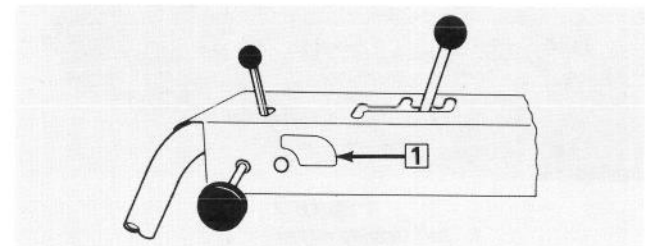

Figure 9

1. Decal

20. Install ignition switch supplied in kit.

21. Connect plug from wiring harness to ignition switch (Fig. 10).

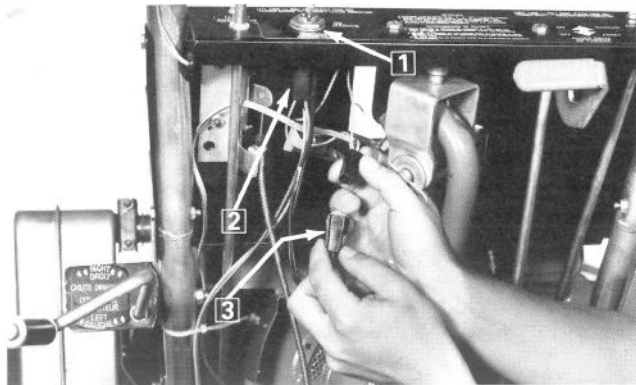

Figure 10

1. Ignition switch and decal
2. Plug from wiring harness
3. Smaller plug on harness

22. Connect smaller plug on harness to existing plug on control panel (Fig. 10).

23. Remove rear engine mounting capscrew and secure wire clamp bracket using capscrew removed (Fig. 11).

24. Secure wiring to wiring clamp bracket with tie wrap (Fig. 11).

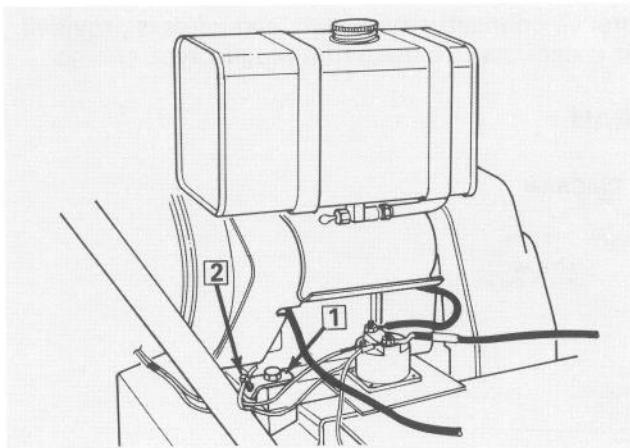

Figure 11

1. Wire clamp bracket
2. Tie wrap

25. Secure wiring to left handle with two tie wrap (Fig. 12).

26. Set battery onto mounting plate of snow thrower. Battery posts must be to the outside, not toward the fuel tank (Fig. 13). Allow about one inch of the battery to extend over outside of mounting plate (Fig. 13).

27. Push clamp at end of black battery cable, which is grounded to engine, onto smallest diameter, negative (-) battery post (Fig. 13). Tighten clamp retaining nut. Next, push clamp at end of black battery cable with red band, which is con-

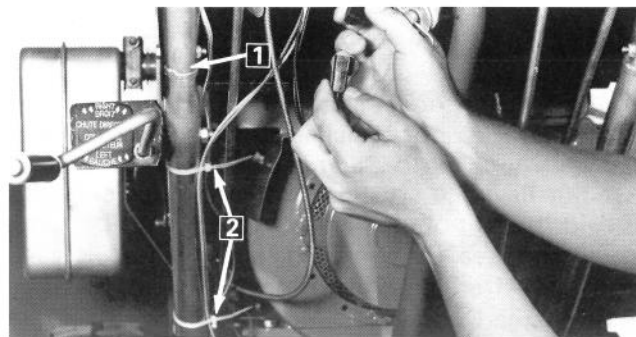

Figure 12

1. Left handle
2. Wire ties

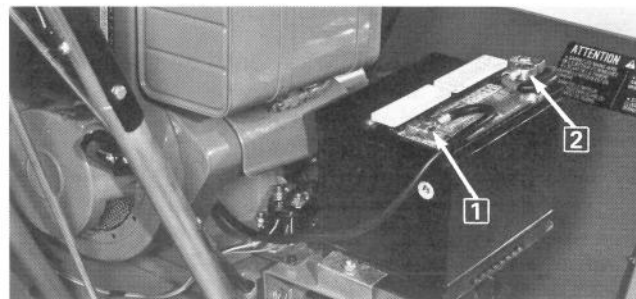

Figure 13

1. Negative
2. Positive

ected to the solenoid, onto the largest diameter, positive (+), battery post (Fig. 13). Tighten clamp retaining nut.

Note: Battery cables must be specially routed on and around the battery (Fig. 13).

28. Install cover on top of battery. Next, slide battery completely onto mounting plate. Secure battery in place with capscrews, battery hold down clamps, and nuts (Fig. 14).

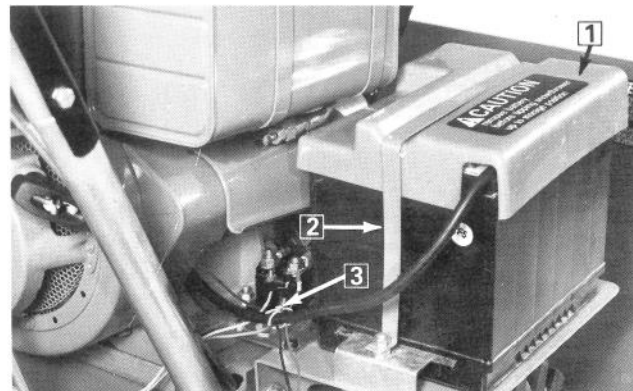

Figure 14

1. Battery cover
2. Battery strap
3. Secure charging plug wires to positive battery cable

29. Install battery strap onto battery cover and slide mounting ends of strap onto ends of capscrews (Fig. 14). Secure all parts in place with two nuts (Fig. 14).

30. Secure charging plug wires to negative battery cable with tie wrap (Fig. 14).

MAINTAINING AND CHARGING BATTERY

Before charging the 12 volt battery, make sure the battery case is not cracked. Also, remove vent caps and look into filler holes. Top of plates must not have ice crystals on them. If ice crystals are evident, do not charge the battery; take battery into warm area (not in living quarters) so it can warm up. After ice crystals are dissolved, battery can be charged.



CAUTION

Charge battery in a well-ventilated area because gases are produced while battery is being charged. Do not inhale the gases because nausea may result. Also, the gases are explosive; therefore, stay away from open flame and electrical spark, and do not smoke while the battery is being charged.

1. Connect charger to charging plug on snowthrower.
2. Plug charger into a grounded outlet of proper voltage.
3. Charge the battery for 24 to 36 hours or follow instructions supplied by manufacturer of charger.



DANGER

Charger must be unplugged from wall outlet before connecting charger to or disconnecting charger from battery or a spark could possibly cause the battery to explode.

4. After battery is charged, remove power cord of charger from wall outlet. Next, disconnect charger from snowthrower.

Note: Engine on Models 38090 and 38150 are not equipped with charging system, therefore battery must be charged periodically. (After 20 starts or every 30 days.)

5. Remove vent caps from battery. Next check level of electrolyte in each cell. Add drinking water to the battery if electrolyte is not up to the ring at bottom of filler neck. **ADD WATER ONLY AFTER CHARGING THE BATTERY.** If large quantity of water again has to be added, install vent caps and charge battery again.

Note: A connector with two lead wires is provided if it is necessary to use a non plug-in type charger.

WIRING DIAGRAM

