



Count on it.

Parts Catalog

21in Heavy-Duty

Recycler®/Rear Bagger Lawn Mower

Model No. 22197—Serial No. 312000001 and Up

Ordering Replacement Parts

To order replacement parts, please supply the part number, the quantity, and the description of each part desired.

Understanding Reference Numbers

Each identified part in an illustration has a reference number. The reference number for a part also appears in the parts list, along with other information about the part.

This catalog uses two special reference number formats, one to indicate parts in a service assembly and another to indicate the quantity of a given part in an illustration.

Service Assembly Reference Numbers

Parts in service assemblies have reference numbers in the form a:b. The a represents the reference number of the entire service assembly and the b represents a sequential number unique to each part within the service assembly.

For example, a wheel assembly might be identified by reference number 6, the tire by 6:1, the valve by 6:2, and the wheel by 6:3. When you order the assembly identified by reference number 6, you receive all parts identified by reference numbers 6:1, 6:2, and 6:3. However, you may also order any part individually. Reference numbers of this type appear in illustration and in parts lists.

Reference Numbers Indicating Quantity

In an illustration, if a reference number indicates more than one part, the reference number has the form nX y. The n represents the quantity of the part, the X is the multiplication symbol, and the y represents the reference number.

For example, in an illustration, the reference number 2X 37 means that two of the parts identified by reference number 37 are indicated.

List of Abbreviations

AR: as required

ASM: assembly

BBC: blade brake control

BHTF: button head thread forming

CARR: carriage

CCW: counter clockwise

CW: clockwise

DEG: degrees

DPA: Dual Point Adjustment

ECM: electronic control module

EXT: external

FH: flat head

GA: gauge

HD: heavy-duty

HF: hex flange

HH: hex head

HHF: hex head flange

HHFTF: hex head flange thread forming

HJ: hex jam

HLH: hex lag head

HOC: height-of-cut

HSBH: hex socket button head

HSFH: hex socket flat head

HSH: hex socket head

HWH: hex washer head

HWHTF: hex washer head thread forming

HYD: hydraulic

LH: left hand

LP: Liquid Propane

NI: nylon insert

NPTF: national pipe thread fine

PFH: phillips flat head

PPH: phillips pan head

PPHTF: phillips pan head thread forming

PRH: phillips round head

PTH: phillips truss head

PTO: power-take-off

RH: right hand

ROPS: roll-over protection system

RRB: rear roller brush

SFH: slotted fillister head

SHH: slotted hex head

SHWH: slotted hex washer head

SPH: slotted pan head

SQH: square head

SRH: slotted round head

STD: standard

TAP: self tapping

TTH: torx truss head

Contents

Housing Assembly	4
Housing Assembly No. 98-7139	6
Wheel and Tire Assembly No. 121-1380	7
Engine and Blade Assembly	8
Handle Assembly	9
Rear Drive and Wheel Assembly	11
Wheel and Tire Assembly No. 121-1379	12
Gear Case Assembly No. 74-1860	13
Grass Bag Assembly No. 121-1391	14
Attachments and Accessories	15

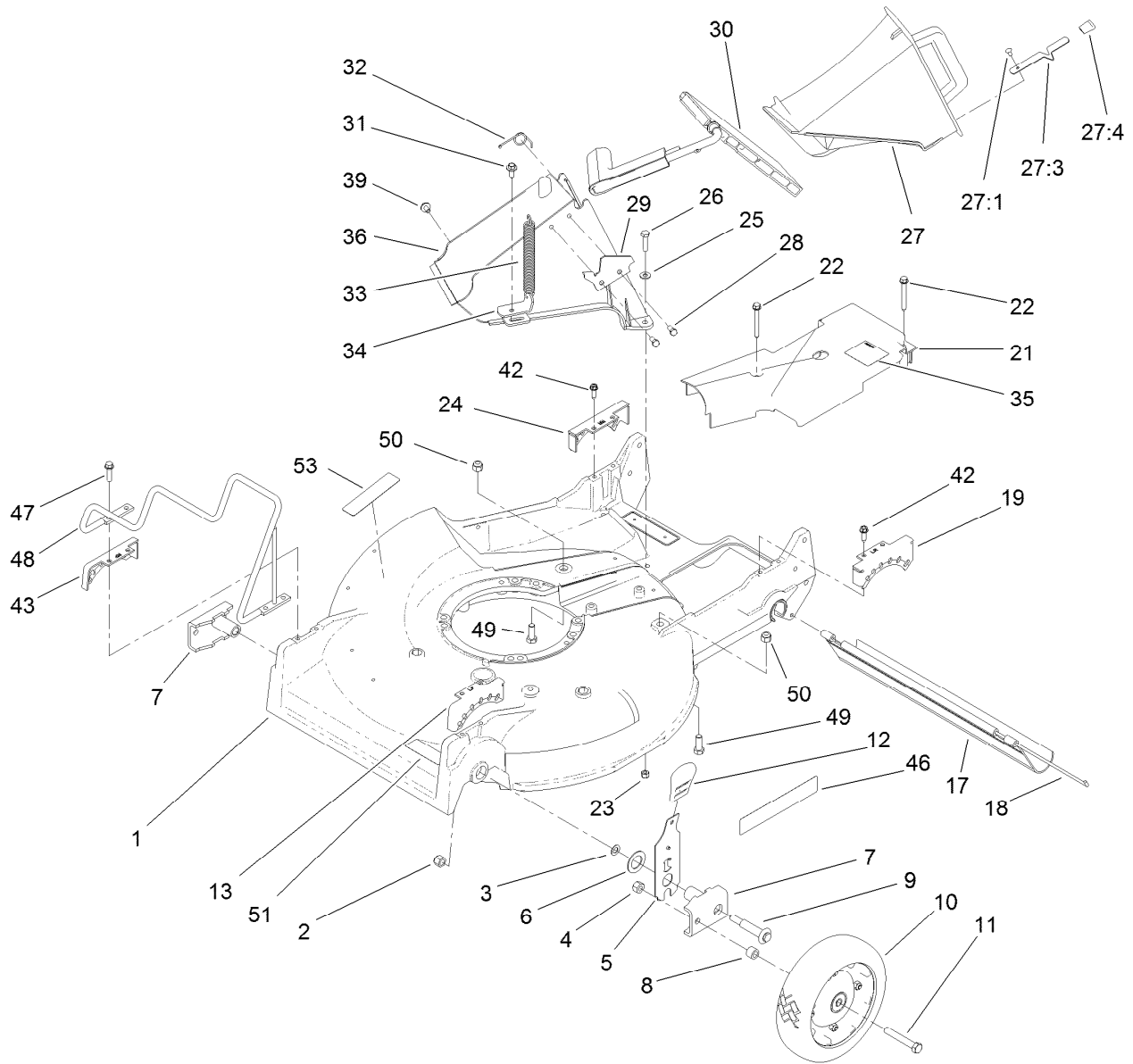

Housing Assembly

Ref.	Part Number	Qty.	Description	Ref.	Part Number	Qty.	Description
1	98-7139	1	Housing	26	321-8	2	Screw-HH
2	3296-6	2	Nut-Lock	27	77-0500	1	Discharge Plug ASM
3	40-1940	2	Washer	27:1	3295-35	1	Rivet-Head, Flat
4	32152-2	2	Nut-Lock, Cone	27:3	76-4640	1	Latch-Plug, Discharge
5	119-2323	2	Front Spring Arm ASM	27:4	76-4650	1	Grip-Latch
6	257-3	2	Washer-Thrust	28	46-8090	2	Screw-Plastite
7	61-8300	2	Arm-Pivot, Front	29	93-3154	1	Latch-Plate
8	52-2480	2	Spacer-Wheel	30	93-7351	1	Discharge Door ASM
9	114-3468	2	Screw-Shoulder	31	46-6811	1	Screw-HWH
10	121-1380	2	Wheel And Tire ASM	32	80-3770	1	Retainer-Door
11	323-12	2	Screw-HH	33	76-4660	1	Spring-Door
12	110-0549	2	Knob-HOC	34	71-9350	1	Bracket-Spring
13	49-8760	1	Quadrant-Front, LH	35	119-7894	1	Decal-Grease
17	112-9989	1	Shield-Trailing	36	82-9152	1	Tunnel-Discharge
18	33-3208	1	Rod-Shield	39	46-6810	1	Screw And Washer ASM
19	49-8740	1	Quadrant-Rear, LH	42	49-2040	4	Screw-HWHTF
21	74-1770	1	Cover-Belt	43	49-8770	1	Quadrant-Front, RH
22	117-5248	2	Screw-HWHTF	46	106-0689	1	Decal
23	3296-42	2	Nut-Lock, NI	47	32144-86	4	Screw-HWHTF
24	49-8750	1	Quadrant-Rear, RH	48	109-7638	1	Guard-Engine
25	3256-22	2	Washer-Flat	49	323-6	2	Screw-HH

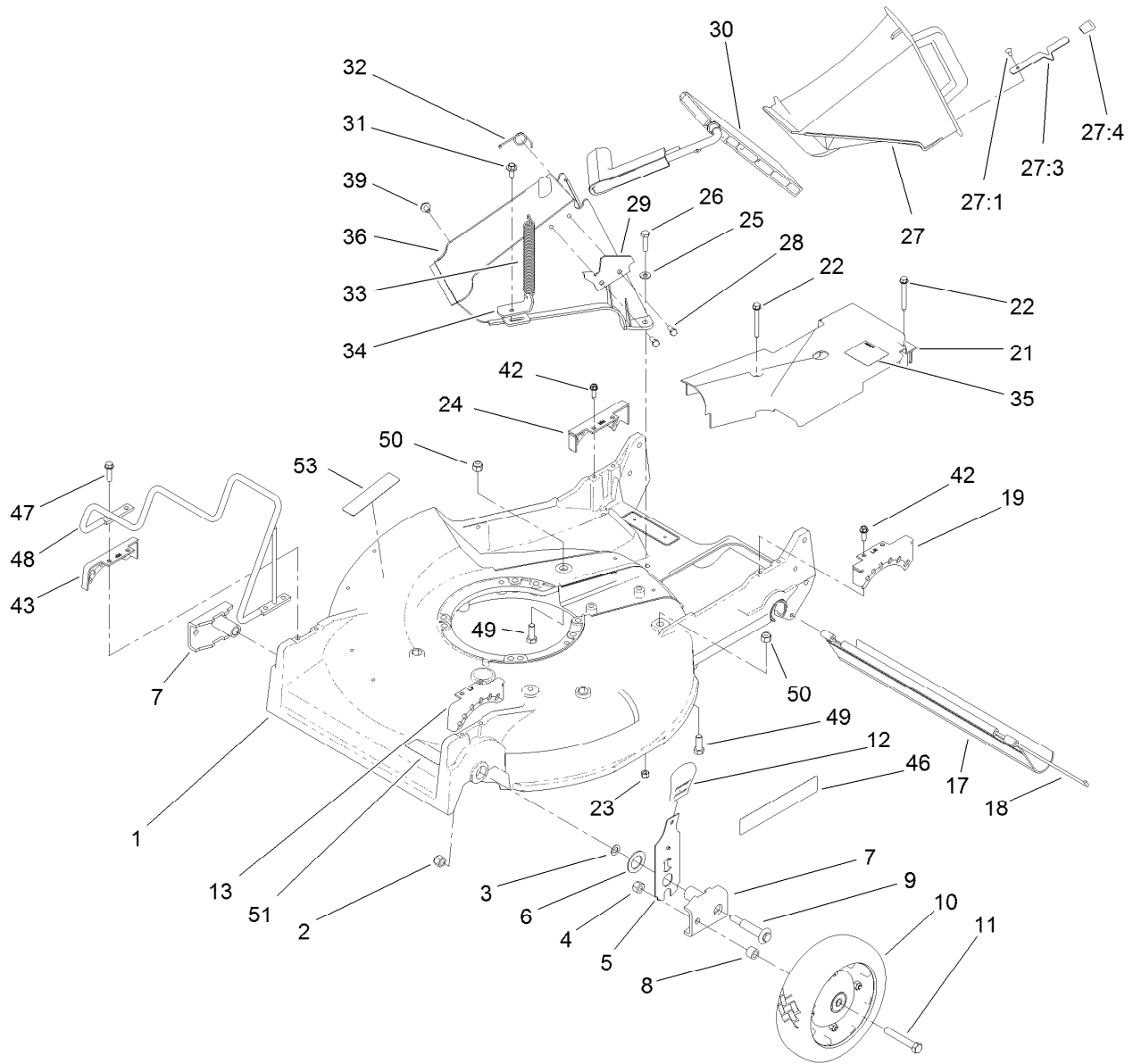

Housing Assembly (continued)

<i>Ref.</i>	<i>Part Number</i>	<i>Qty.</i>	<i>Description</i>	<i>Ref.</i>	<i>Part Number</i>	<i>Qty.</i>	<i>Description</i>
50	3296-39	2	Nut-Lock, NI	51	68-7410	1	Decal-Blade
				53	117-2718	1	Decal-Arrester, Spark

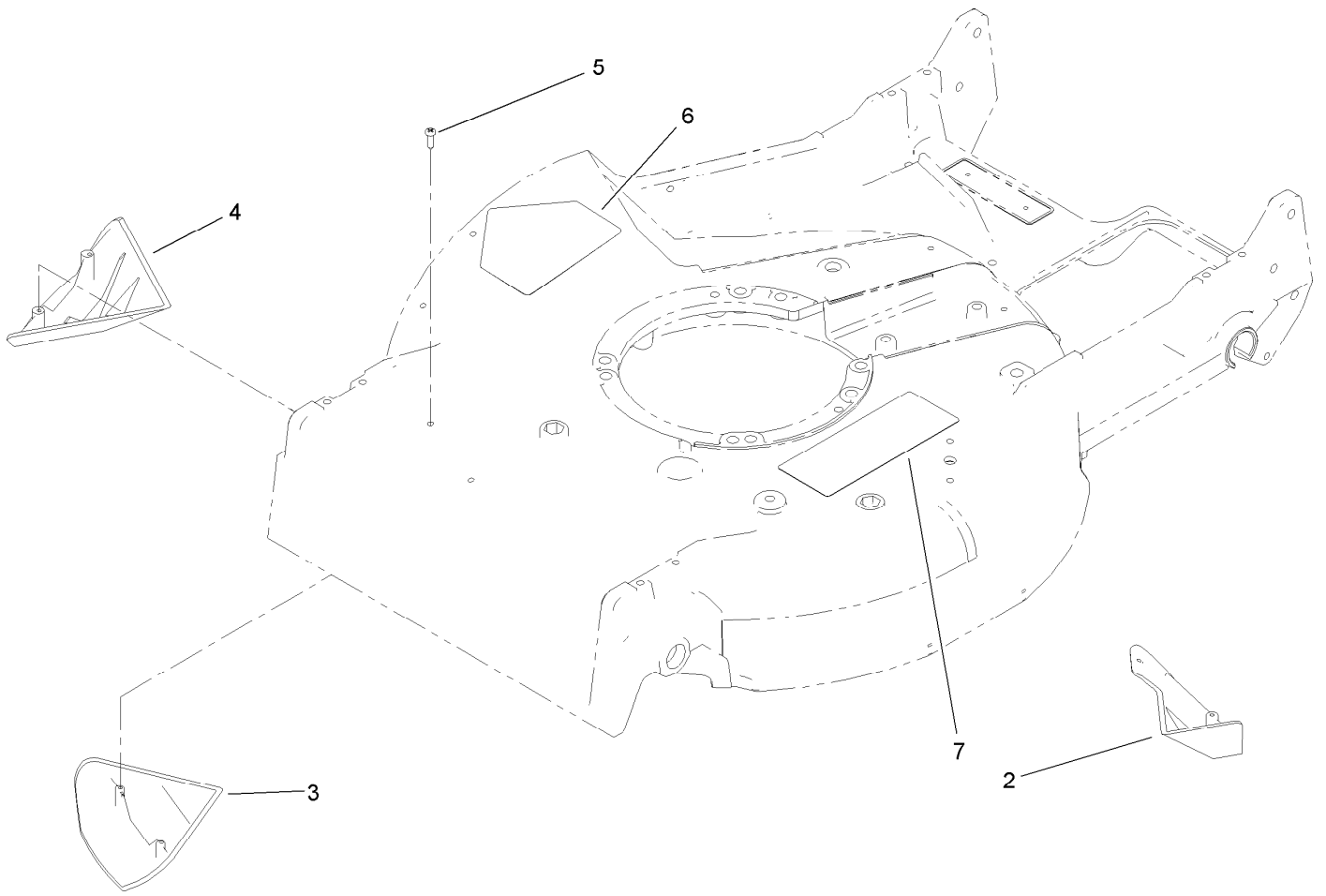

Housing Assembly No. 98-7139

<i>Ref.</i>	<i>Part Number</i>	<i>Qty.</i>	<i>Description</i>
2	92-1750	1	Kicker-Rear
3	92-1720	1	Kicker-Front
4	92-1730	1	Kicker-RH
5	32144-111	6	Screw-PPH
6	94-8072	1	Decal-Danger
7	110-4989	1	Decal-Warning

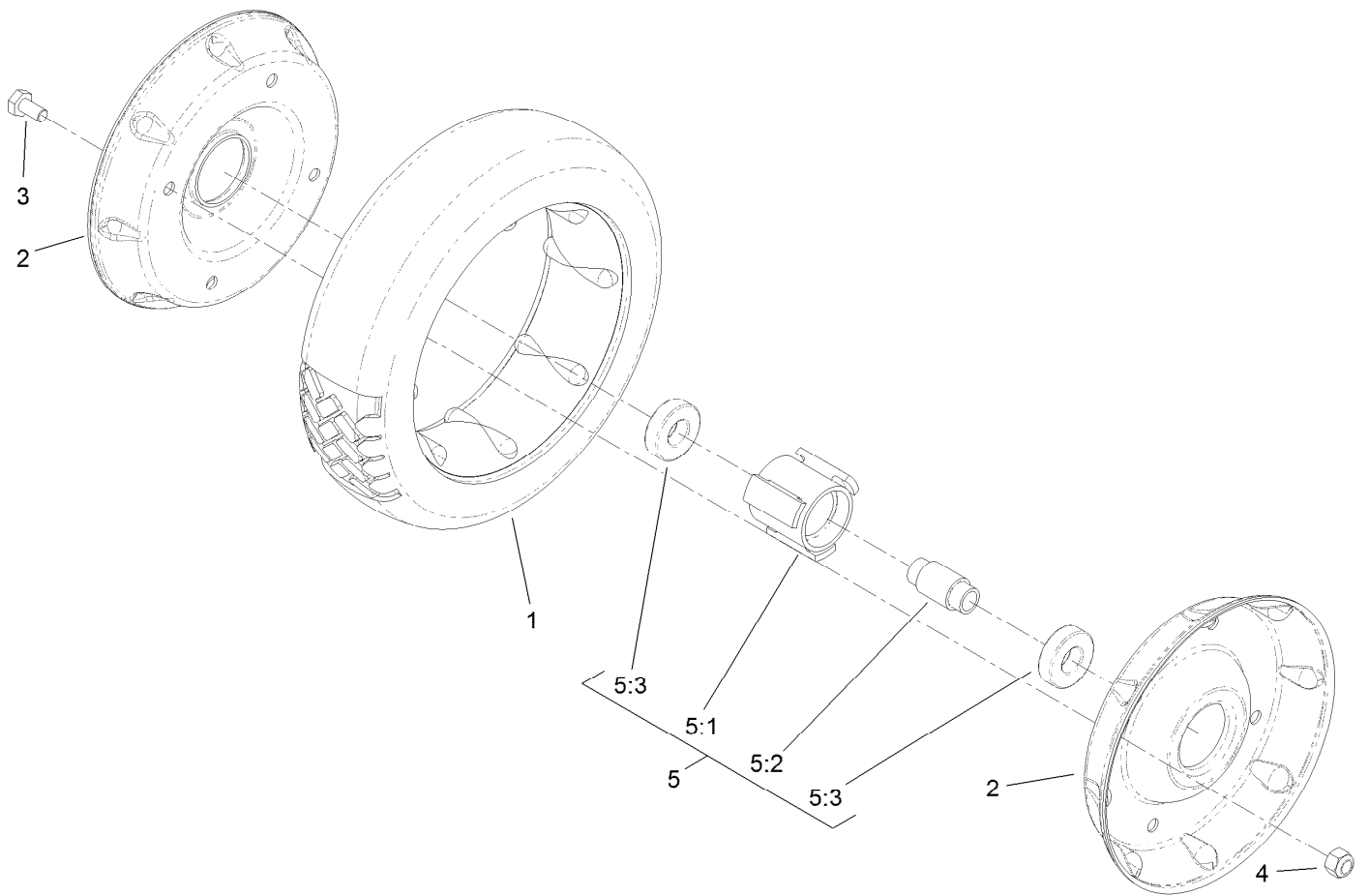

Wheel and Tire Assembly No. 121-1380

<i>Ref.</i>	<i>Part Number</i>	<i>Qty.</i>	<i>Description</i>
1	53-7740	1	Tire
2	121-1365-06	2	Rim-Half, Wheel
3	321-2	4	Screw-HH
4	3296-42	4	Nut-Lock, NI
5	121-1377	1	Hub And Bearing ASM
5:1	52-2410	1	Hub-Bearing
5:2	52-2440	1	Spacer-Bearing
5:3	109-8020	2	Bearing-Ball

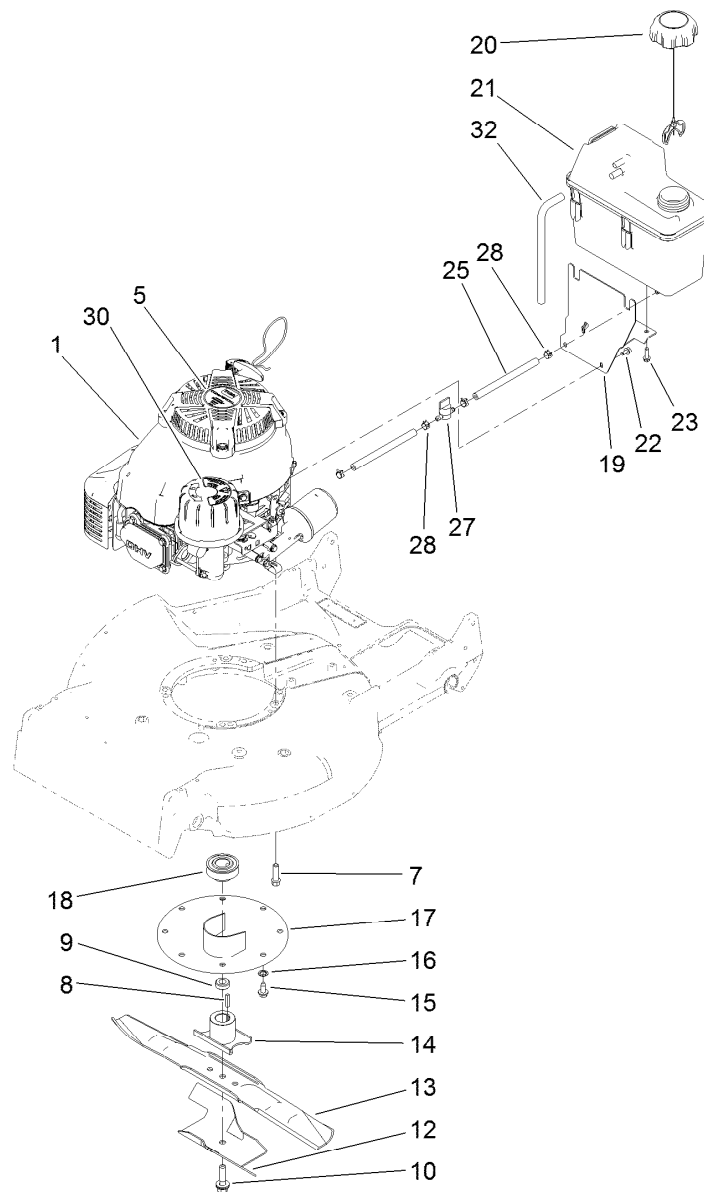

Engine and Blade Assembly

<i>Ref.</i>	<i>Part Number</i>	<i>Qty.</i>	<i>Description</i>	<i>Ref.</i>	<i>Part Number</i>	<i>Qty.</i>	<i>Description</i>
1	117-5222	1	Engine-Kawasaki, Fj180V-Am08-M	17	121-1360	1	Crankshaft Protector ASM
5	110-0520	1	Decal	18	46-7910	1	Pulley-Driver
7	95-1727	4	Screw-Taptite	19	115-0954-03	1	Tank Mount ASM
8	5-1077	1	Key-Square	20	109-6776	1	Cap-Ratchet, Tethered
9	103-3795	1	Spacer-Retainer, Blade	21	114-0280	1	Tank-Fuel
10	105-8579	1	Bolt-Blade	22	104-2628	3	Screw-HWH
12	92-1599-03	1	Stiffener-Blade	23	46-8091	2	Screw-HWH
13	91-2256-03	1	Blade-21 Inch	25	107-0588	2	Hose-Fuel
14	52-2170-03	1	Retainer-Blade ASM	27	1-603770	1	Valve-Fuel
15	32144-70	3	Screw-HWHTF	28	2412-98	4	Clamp-Hose
16	3254-6	3	Washer-Lock, Internal	30	114-3415	1	Decal-Air Cleaner
				32	115-0962	1	Hose-Vent, Canister

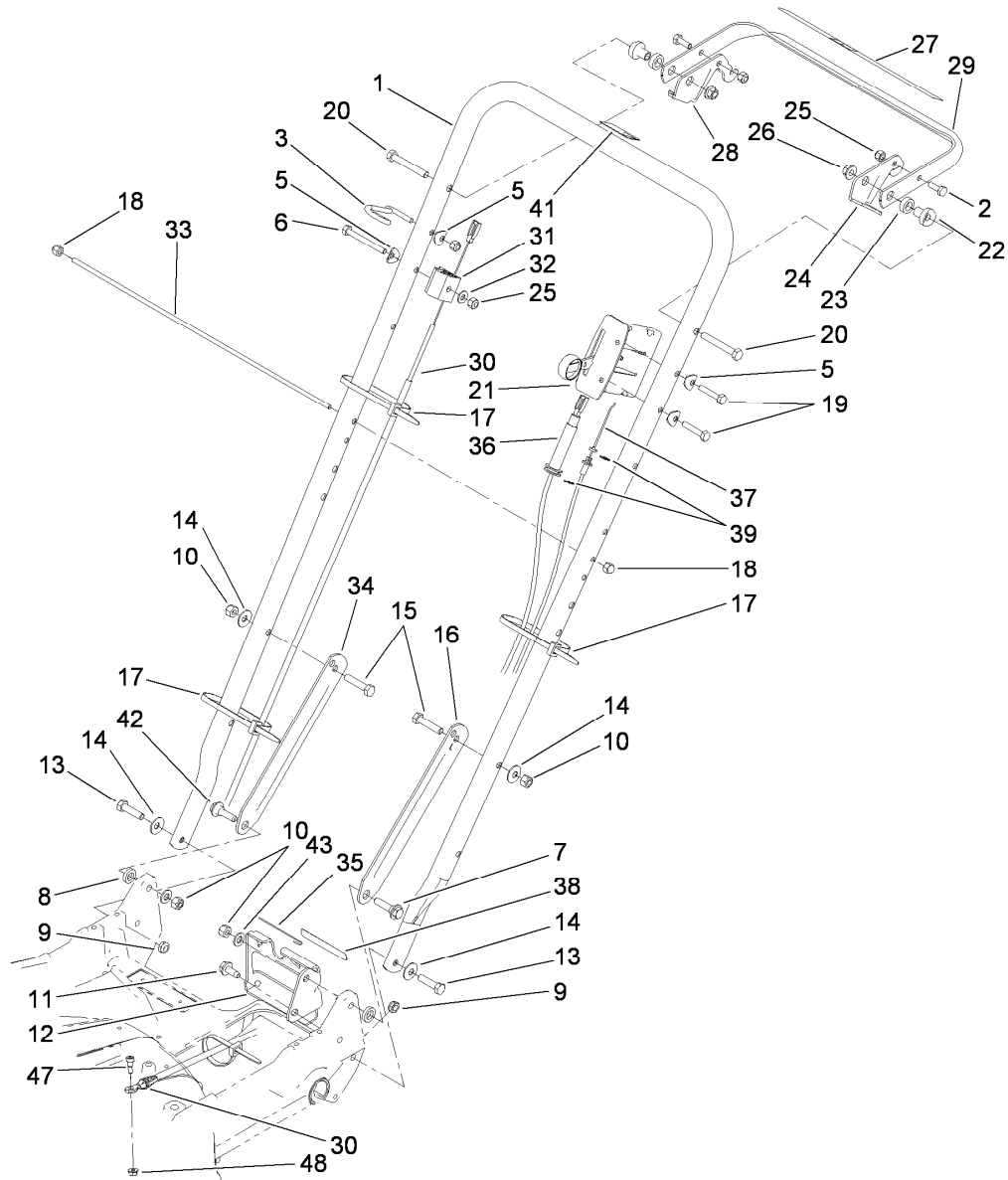

Handle Assembly

<i>Ref.</i>	<i>Part Number</i>	<i>Qty.</i>	<i>Description</i>	<i>Ref.</i>	<i>Part Number</i>	<i>Qty.</i>	<i>Description</i>
1	98-2000-03	1	Handle	22	49-1630	2	Spacer-Support
2	321-4	2	Screw-HH	23	256-276	2	Spacer-Nylon
3	114-2775	1	Guide-Rope	24	66-5350	1	Lever-Control
5	3-7501	4	Washer	25	3296-42	4	Nut-Lock, NI
6	321-15	1	Screw-HH	26	104-8300	2	Nut-Flange, NI
7	27-7210	1	Screw-Shoulder	27	106-0690	1	Decal-Traction
8	3-3287	2	Spacer	28	77-5270	1	Lever-Control
9	3296-47	2	Nut-Lock, NI	29	61-8270-03	1	Bar-Control
10	3296-29	4	Nut-Lock, NI	30	114-3483	1	Cable-Brake, Control
11	32144-70	1	Screw-HWHTF	31	46-6980	1	Support-Cable
12	74-1741	1	Bracket-Adjustment, Traction	32	3256-22	1	Washer-Flat
13	322-6	2	Screw-HH	33	48-2810	1	Rod-Support, Bag
14	3290-456	4	Washer-Belleville	34	100-3297-03	1	Latch-Handle, RH
15	322-7	2	Screw-HH	35	46-7030	1	Retainer-Cable
16	100-3298-03	1	Latch-Handle, LH	36	74-1791	1	Cable-Traction
17	3290-378	4	Tie-Cable	37	106-0888	1	Throttle Cable ASM
18	32111-7	2	Nut-Cap	38	74-1970	1	Decal-Position, Gear
19	321-13	2	Screw-HH	39	32151-86	2	E-Ring
20	322-11	2	Screw-HH	41	98-4387	1	Decal-Protection, Ear
21	108-2645	1	Control-Head, Throttle	42	27-7211	1	Screw-Shoulder
				43	3256-23	2	Washer-Flat

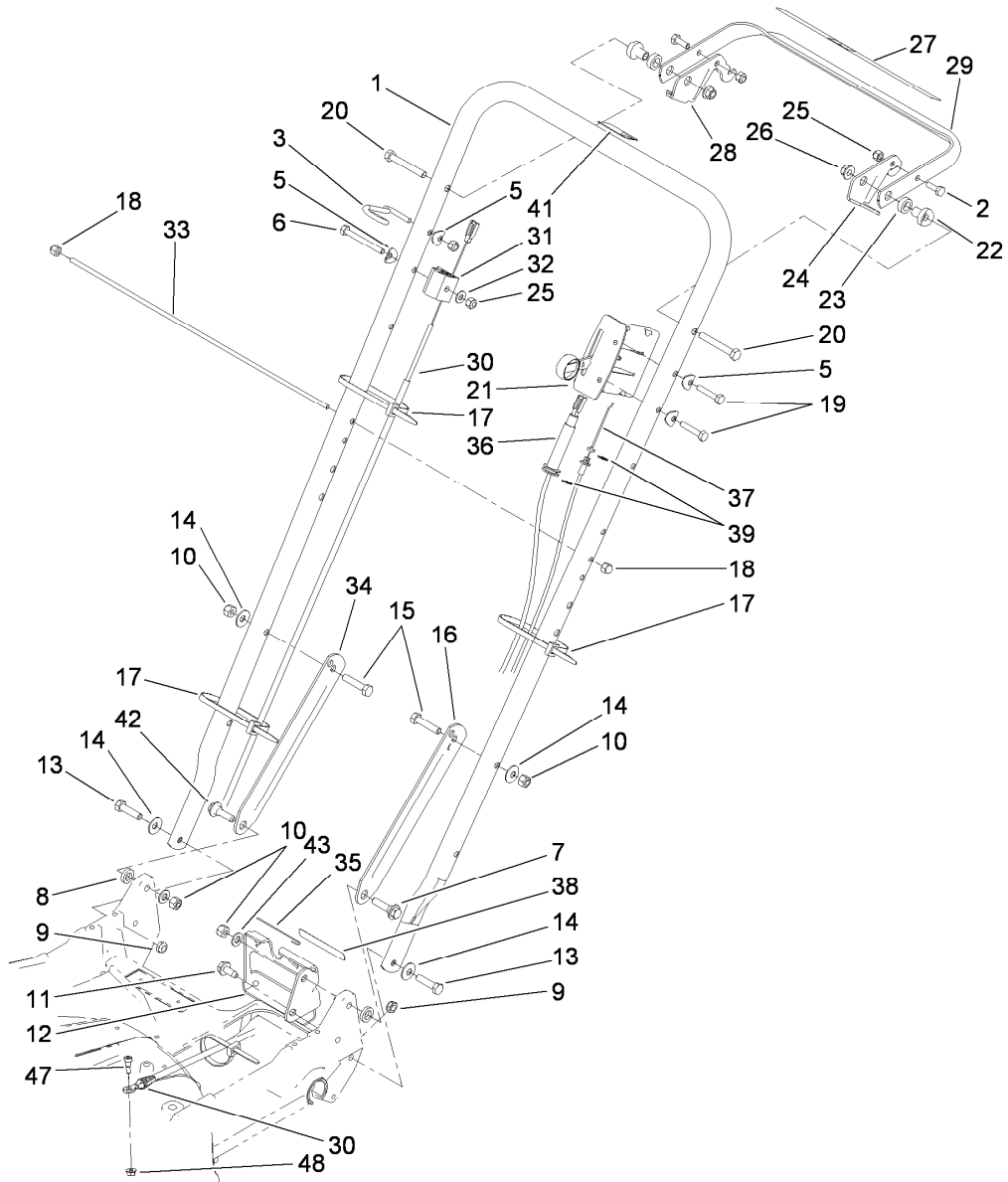

Handle Assembly (continued)

<i>Ref.</i>	<i>Part Number</i>	<i>Qty.</i>	<i>Description</i>
47	94-9422	1	Screw-Shoulder
48	32128-17	1	Nut-Lock, Flange

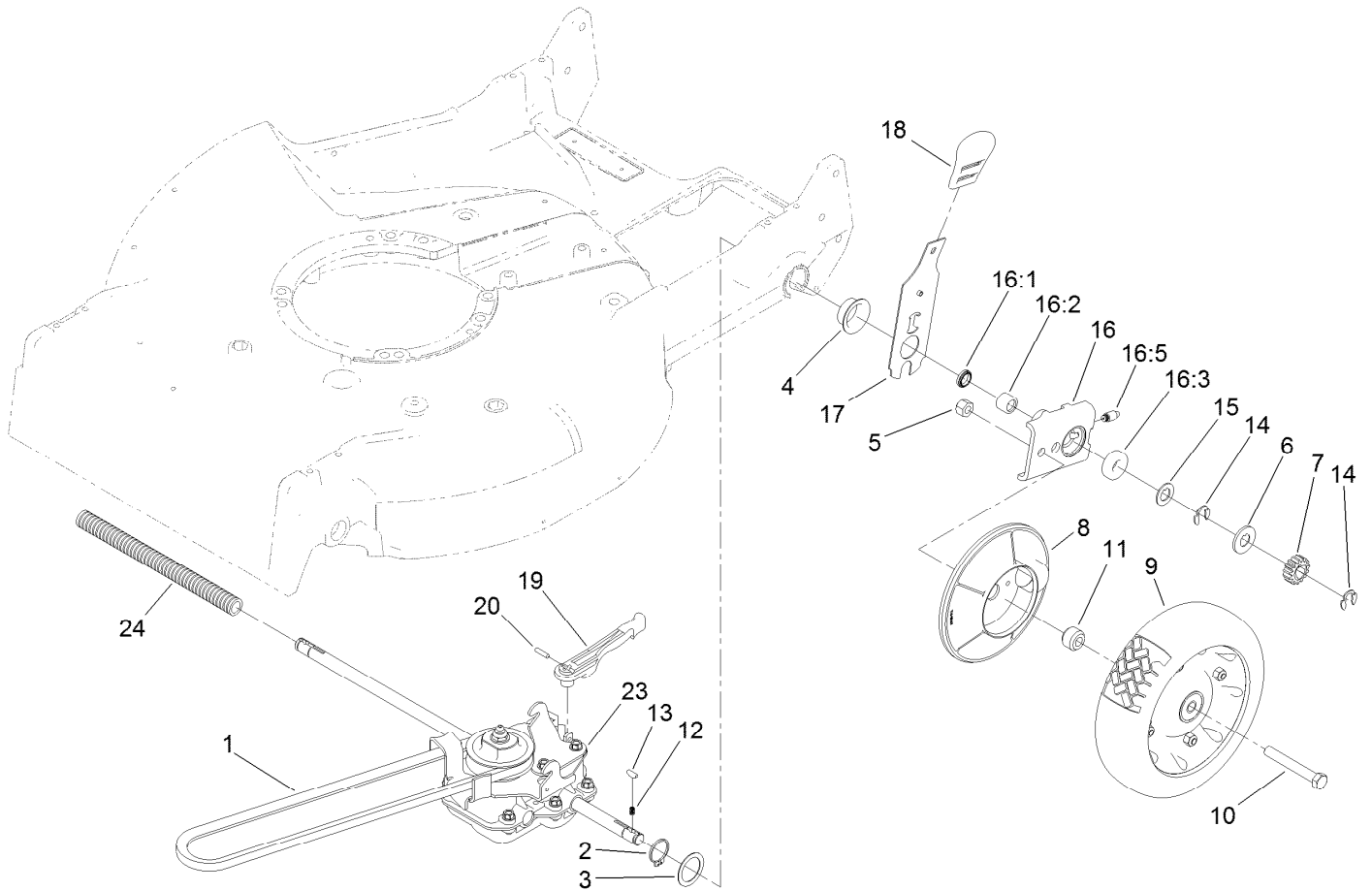

Rear Drive and Wheel Assembly

<i>Ref.</i>	<i>Part Number</i>	<i>Qty.</i>	<i>Description</i>	<i>Ref.</i>	<i>Part Number</i>	<i>Qty.</i>	<i>Description</i>
1	36-8070	1	V-Belt	15	49-7700	2	Washer-Thrust, Outer
2	32151-36	2	Ring-Retaining	16	74-1851	2	Pivot Arm ASM
3	74-1810	2	Washer	16:1	47-6730	1	Seal-Oil
4	48-2170	2	Cap-End	16:2	117-3500	1	Bearing-Caged Needle Roller
5	32152-2	2	Nut-Lock, Cone	16:3	52-2450	1	Bearing-Wheel
6	62-3830	2	Washer-Thrust, Outer	16:5	92-6316	1	Zerk
7	39-9160	2	Gear-Pinion	17	119-2324	2	Rear Spring Arm ASM
8	74-1640	2	Cover-Wheel	18	110-0549	2	Knob-HOC
9	121-1379	2	Wheel And Tire ASM	19	74-1960	1	Lever-Shift
10	323-13	2	Screw-HH	20	32121-99	1	Pin-Coil
11	74-1650	2	Spacer-Cover, Wheel	23	74-1860	1	Gear Case ASM
12	39-9650	2	Spring-Compression	24	121-1357	1	Cover-Shaft, Drive
13	612066	2	Key				
14	32151-68	4	Ring-Retaining				

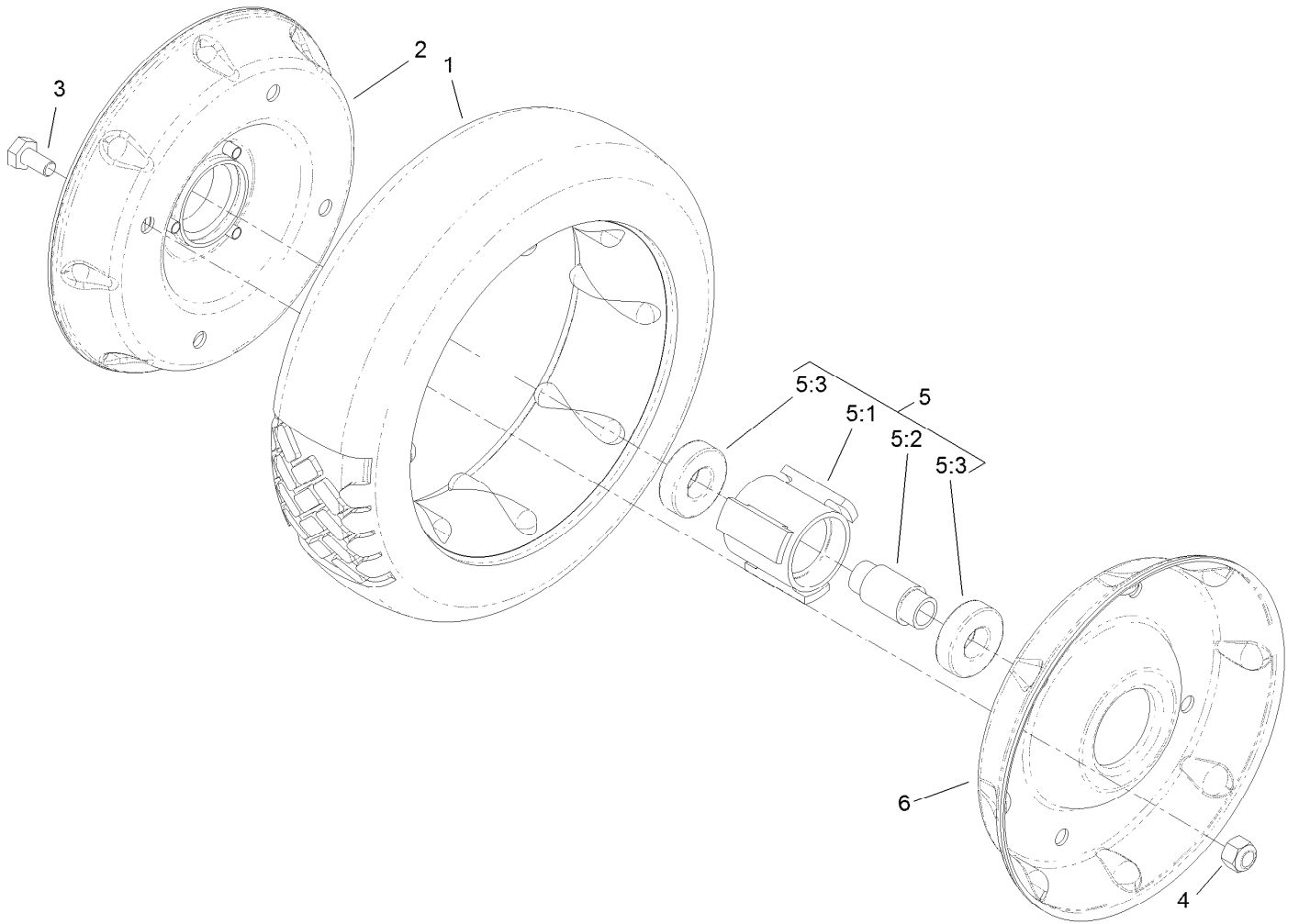

Wheel and Tire Assembly No. 121-1379

<i>Ref.</i>	<i>Part Number</i>	<i>Qty.</i>	<i>Description</i>
1	53-7740	1	Tire
2	121-1378-06	1	Wheel Half And Gear ASM
3	321-2	4	Screw-HH
4	3296-42	4	Nut-Lock, NI
5	121-1377	1	Hub And Bearing ASM
5:1	52-2410	1	Hub-Bearing
5:2	52-2440	1	Spacer-Bearing
5:3	109-8020	2	Bearing-Ball
6	121-1365-06	1	Rim-Half, Wheel

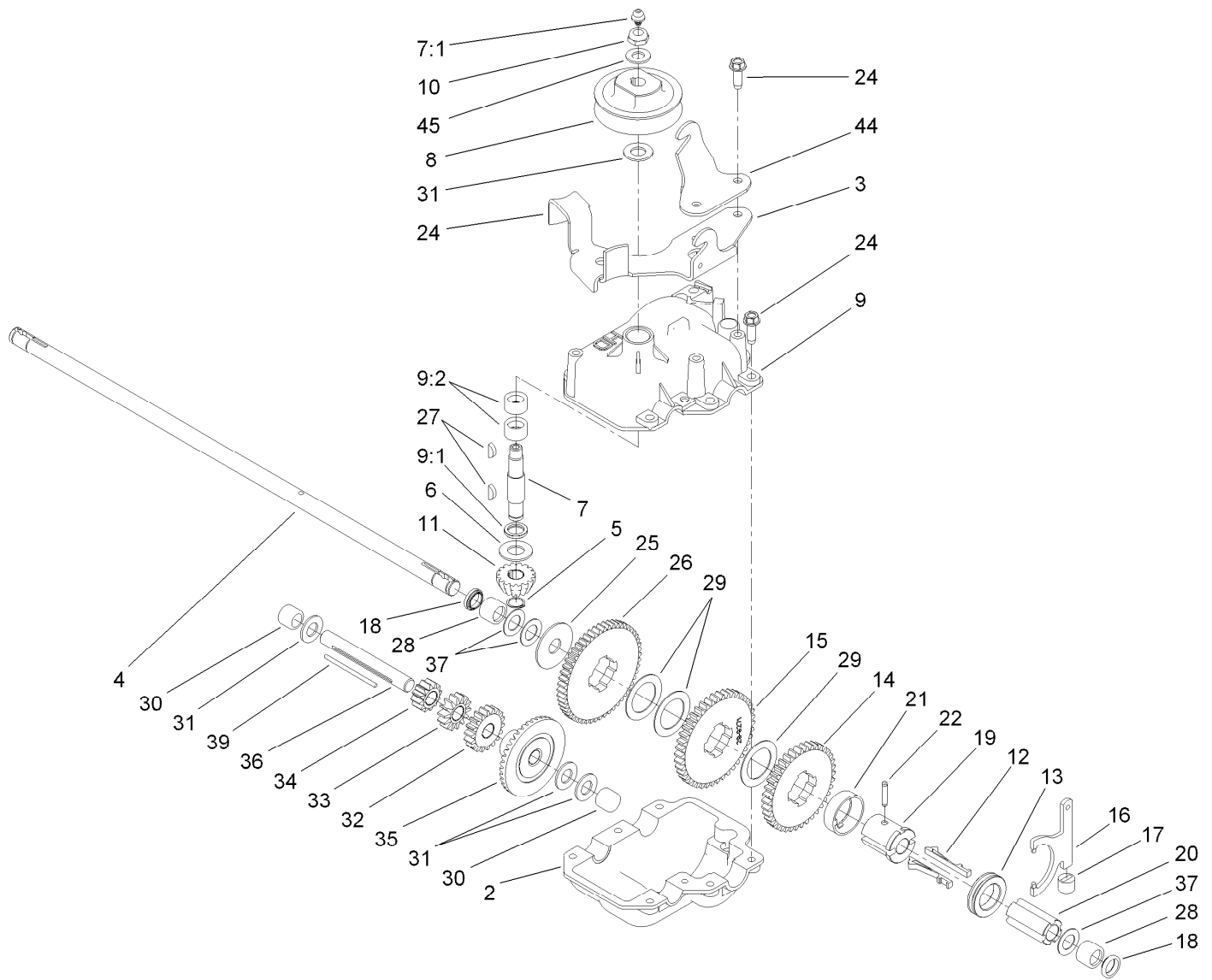

Gear Case Assembly No. 74-1860

Ref.	Part Number	Qty.	Description	Ref.	Part Number	Qty.	Description
2	119-7863	1	Gearcase-Lower	20	39-6720	1	Sleeve
3	49-8461-03	1	Bracket-Guide, Belt	21	55-8020	1	Retainer-Key
4	74-1890	1	Shaft-Output	22	3285-19	1	Pin-Groove
5	32151-57	1	Ring-Retaining	24	49-2040	8	Screw-HWHTF
6	47-2910	1	Washer-Thrust	25	29-9690	1	Washer
7	13-5149	1	Input Shaft ASM	26	46-3560	1	Gear
7:1	302-63	1	Zerk	27	3257-1	2	Key-Woodruff
8	39-6740	1	Pulley	28	117-3500	2	Bearing-Caged Needle Roller
9	13-9739	1	Upper Gearcase ASM	29	36-4770	3	Washer
9:1	47-7260	1	Seal	30	252-103	2	Bearing-Needle, Closed
9:2	47-7270	2	Bearing-Needle	31	36-4792	4	Washer-Thrust
10	3296-5	1	Nut-Lock	32	39-6650	1	Gear-18T
11	39-6660	1	Pinion-Bevel	33	46-3550	1	Gear-14T
12	29-9330	2	Key-Shift	34	46-3540	1	Gear-12T
13	29-9340	1	Collar-Shift	35	74-1760	1	Gear-Bevel
14	42-4740	1	Gear-38T	36	53-7950	1	Shaft-Intermediate
15	29-9271	1	Gear-42T	37	36-4780	4	Washer-Plain
16	60-8870	1	Yoke-Shift	39	39-7842	1	Key
17	29-9570	1	Bushing-Yoke	44	74-1750-03	1	Bracket-Engage, Traction
18	47-6730	2	Seal-Oil	45	3256-45	1	Washer-Flat
19	55-8010	1	Sleeve-Gear				

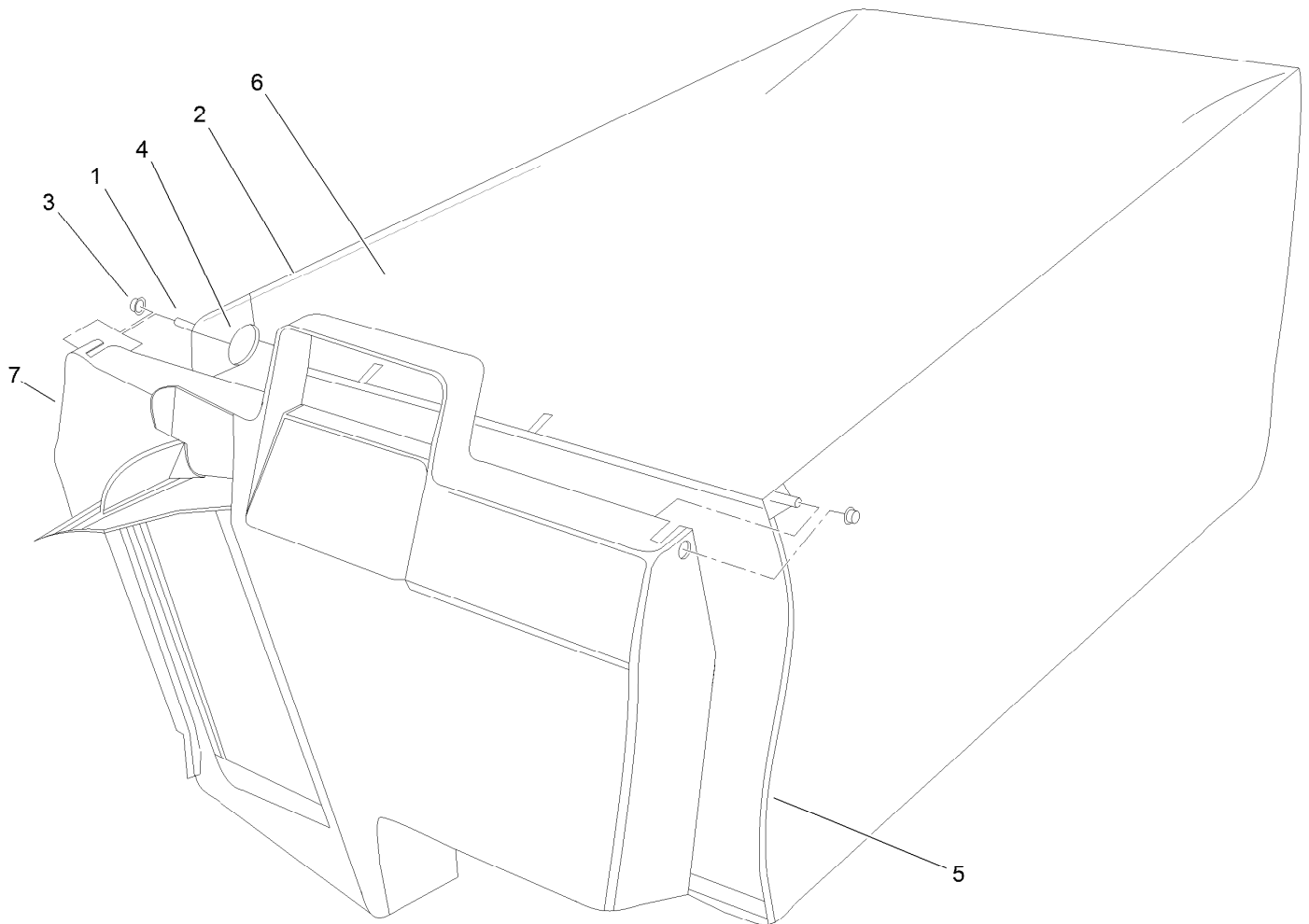

Grass Bag Assembly No. 121-1391

<i>Ref.</i>	<i>Part Number</i>	<i>Qty.</i>	<i>Description</i>
1	33-4820	1	Hinge-Door, Bag
2	121-1388	1	Frame-Bag, Upper
3	3290-422	2	Nut-Push
4	36-6910	2	Spring
5	42-4020	1	Frame-Bag
6	106-0926	1	Bag-Grass
7	121-1389	1	Door-Bag, Grass

Attachments and Accessories

For 22197 21in Heavy-Duty Recycler/Rear Bagger Lawn Mower

Product Name	Model/Part
Blade-Atomic, 21in	104-1302
Bag-Large, Walk Behind (Toro).....	490-7315
Bag-Walk Behind (Toro).....	490-7318
Bag-Large, Walk Behind	490-7322
Bag-Walk Behind	490-7325
Cover-Lawnmower	490-7462
Side Discharge Kit	59199



Count on it.