



**Count on it.**

**Parts Catalog**

**TimeCutter® ZS 5000 Riding  
Mower**

**Model No. 74387—Serial No. 31200001 and Up**

# Ordering Replacement Parts

To order replacement parts, please supply the part number, the quantity, and the description of each part desired.

## Understanding Reference Numbers

Each identified part in an illustration has a reference number. The reference number for a part also appears in the parts list, along with other information about the part.

This catalog uses two special reference number formats, one to indicate parts in a service assembly and another to indicate the quantity of a given part in an illustration.

## Service Assembly Reference Numbers

Parts in service assemblies have reference numbers in the form a:b. The a represents the reference number of the entire service assembly and the b represents a sequential number unique to each part within the service assembly.

For example, a wheel assembly might be identified by reference number 6, the tire by 6:1, the valve by 6:2, and the wheel by 6:3. When you order the assembly identified by reference number 6, you receive all parts identified by reference numbers 6:1, 6:2, and 6:3. However, you may also order any part individually. Reference numbers of this type appear in illustration and in parts lists.

## Reference Numbers Indicating Quantity

In an illustration, if a reference number indicates more than one part, the reference number has the form nX y. The n represents the quantity of the part, the X is the multiplication symbol, and the y represents the reference number.

For example, in an illustration, the reference number 2X 37 means that two of the parts identified by reference number 37 are indicated.

# List of Abbreviations

**AR:** as required

**ASM:** assembly

**BBC:** blade brake control

**BHTF:** button head thread forming

**CARR:** carriage

**CCW:** counter clockwise

**CW:** clockwise

**DEG:** degrees

**DPA:** Dual Point Adjustment

**ECM:** electronic control module

**EXT:** external

**FH:** flat head

**GA:** gauge

**HD:** heavy-duty

**HF:** hex flange

**HH:** hex head

**HHF:** hex head flange

**HHFTF:** hex head flange thread forming

**HJ:** hex jam

**HLH:** hex lag head

**HOC:** height-of-cut

**HSBH:** hex socket button head

**HSFH:** hex socket flat head

**HSH:** hex socket head

**HWH:** hex washer head

**HWHTF:** hex washer head thread forming

**HYD:** hydraulic

**LH:** left hand

**LP:** Liquid Propane

**NI:** nylon insert

**NPTF:** national pipe thread fine

**PFH:** phillips flat head

**PPH:** phillips pan head

**PPHTF:** phillips pan head thread forming

**PRH:** phillips round head

**PTH:** phillips truss head

**PTO:** power-take-off

**RH:** right hand

**ROPS:** roll-over protection system

**RRB:** rear roller brush

**SFH:** slotted fillister head

**SHH:** slotted hex head

**SHWH:** slotted hex washer head

**SPH:** slotted pan head

**SQH:** square head

**SRH:** slotted round head

**STD:** standard

**TAP:** self tapping

**TTH:** torx truss head

# Contents

Frame, Front Axle and Caster Wheel Assembly .....	4
13 Inch Wheel and Tire Assembly .....	5
Motion Control Assembly .....	6
Seat Assembly .....	8
Hydro Transaxle Assembly .....	9
RH Hydro Transaxle Assembly No. 119-3351 .....	10
LH Hydro Transaxle Assembly No. 119-3350 .....	12
Belt and Pulley Assembly .....	14
Clutch Assembly .....	15
Engine and Exhaust Assembly .....	16
Body Styling and Fuel Pod Assembly .....	17
Fuel Delivery Assembly .....	18
Electrical Assembly .....	19
Deck Lift Assembly .....	20
50 Inch Deck Assembly .....	21
50 Inch Deck Decal Assembly No. 119-8841 .....	22
50 Inch Deck Baffle Assembly .....	23
50 Inch Deck, Belt and Mulch Blade Assembly .....	24
Attachments and Accessories .....	25

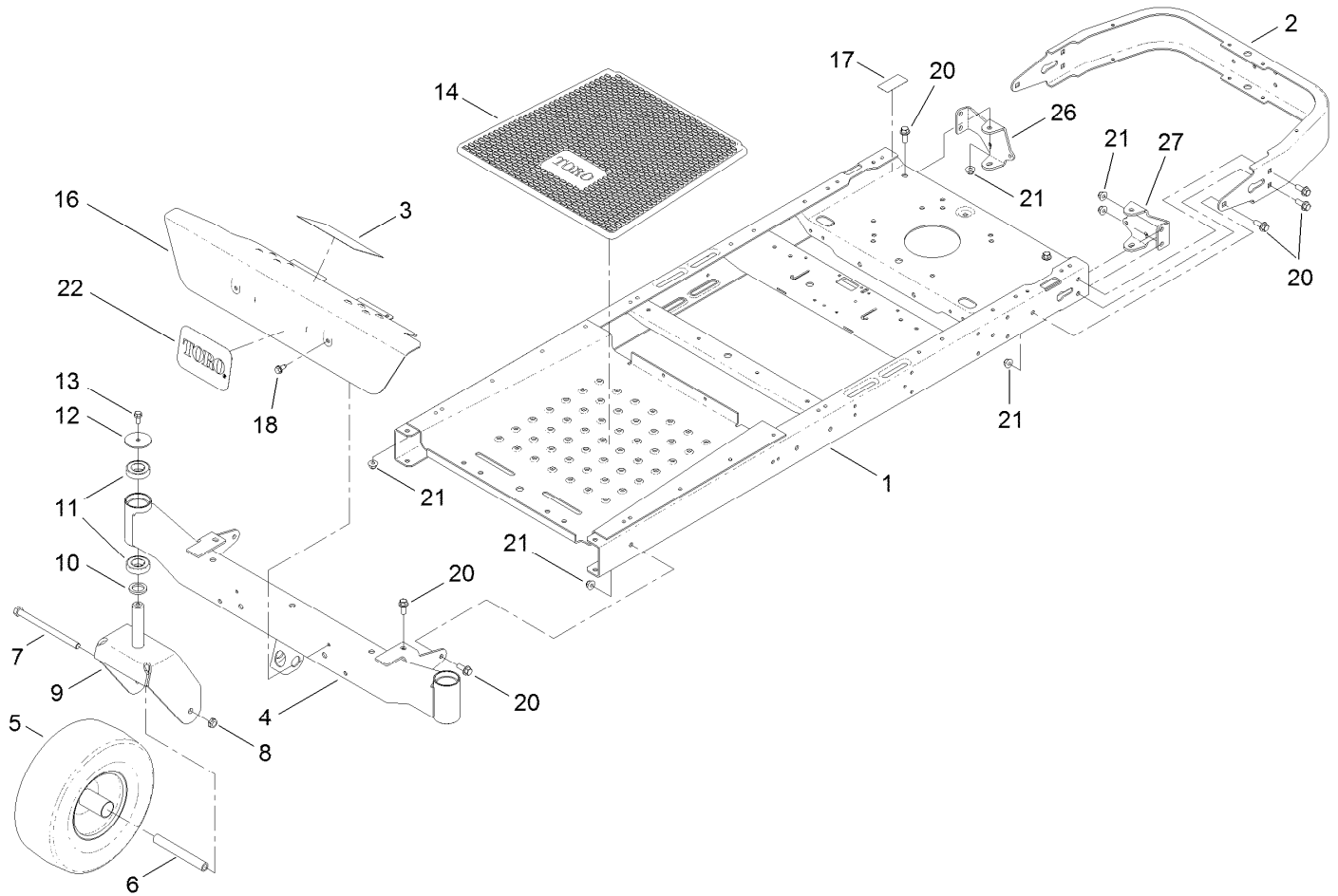

## Frame, Front Axle and Caster Wheel Assembly

<i>Ref.</i>	<i>Part Number</i>	<i>Qty.</i>	<i>Description</i>	<i>Ref.</i>	<i>Part Number</i>	<i>Qty.</i>	<i>Description</i>
1	120-7963-01	1	Frame ASM	12	119-8915	2	Washer
2	117-7415-01	1	Bumper-Rear (Wide)	13	3234-47	2	Screw-HHF
3	120-2239	1	Decal-Danger	14	120-5454	1	Mat-Floor
4	120-5513-01	1	Axle-Front, Wide	16	117-7424-03	1	Footrest
5	119-3473	2	13 Inch Wheel And Tire ASM	17	121-2989	2	Decal-Bypass
6	119-3475	2	Spanner	18	32144-70	2	Screw-HWHTF
7	325-37	2	Screw-HH	20	3234-42	14	Screw-HHF
8	3296-45	2	Nut-Lock, NI	21	104-8301	14	Nut-Flange, NI
9	119-3349-01	2	Fork-Caster, Wide	22	99-4693	1	Decal
10	117-7394	2	Washer-Thrust	26	121-0737-01	1	Mount-Hydro, Rear RH
11	109-3678	4	Bearing-Ball	27	121-0738-01	1	Mount-Hydro, Rear LH

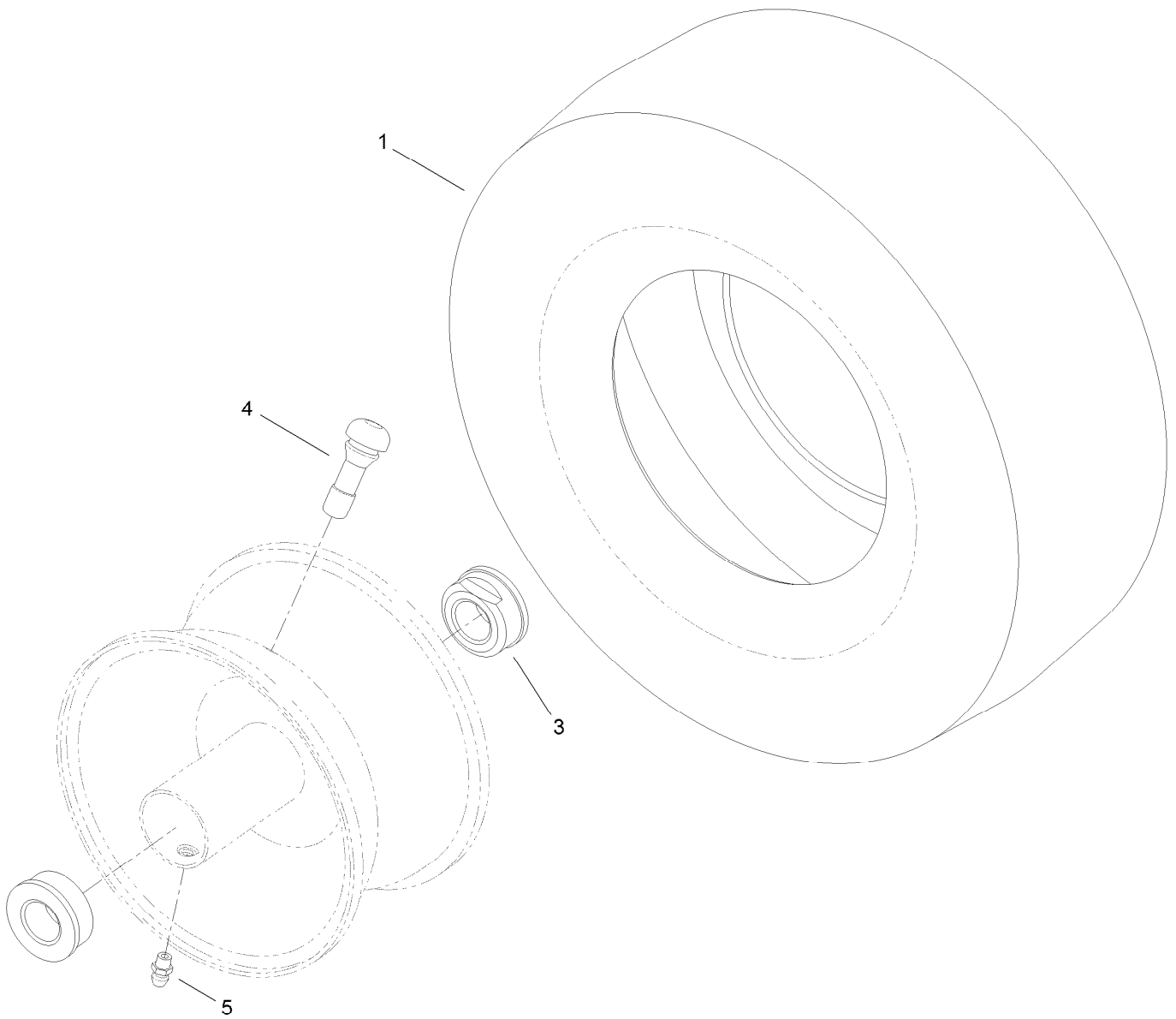

## 13 Inch Wheel and Tire Assembly

<i>Ref.</i>	<i>Part Number</i>	<i>Qty.</i>	<i>Description</i>
1	119-3471	1	Tire-13 Inch
3	114-1640	2	Bushing-Flange
4	232-27	1	Stem-Valve
5	302-5	1	Fitting-Grease

# Motion Control Assembly

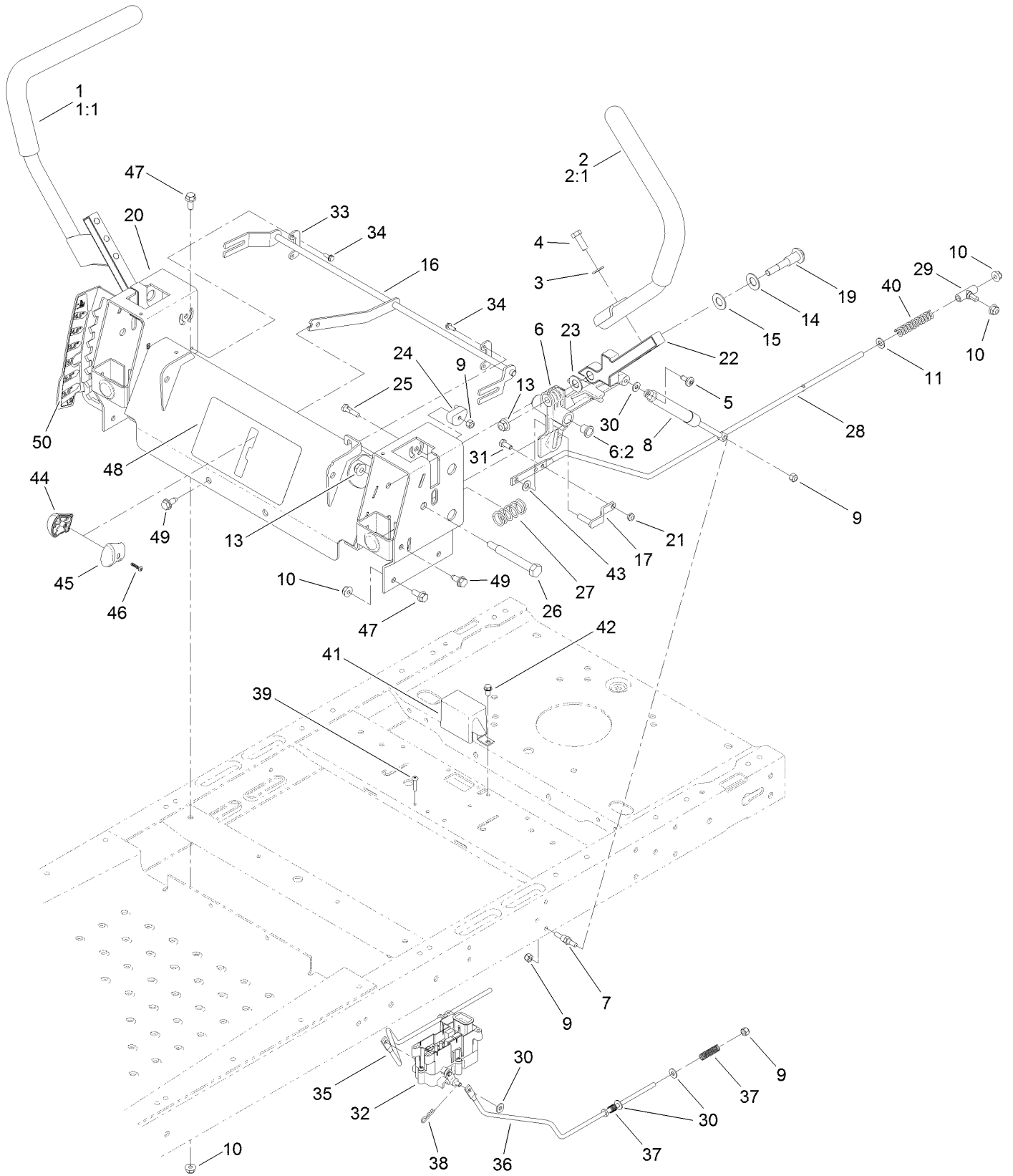

## Motion Control Assembly (continued)

<i>Ref.</i>	<i>Part Number</i>	<i>Qty.</i>	<i>Description</i>	<i>Ref.</i>	<i>Part Number</i>	<i>Qty.</i>	<i>Description</i>
1	121-0731	1	Handle-Control, RH	26	115-5099	2	Bolt-Pivot
1:1	121-0726	1	Grip	27	119-8876	2	Spring-Return
2	121-0730	1	Handle-Control, LH	28	117-5388	2	Rod-Hydro
2:1	121-0726	1	Grip	29	119-8842	2	Mount-Rod, Hydro
3	3256-24	4	Washer-Flat	30	119-8952	8	Washer
4	323-6	4	Screw-HH	31	321-3	2	Screw-HH
5	120-7950	2	Screw-Shoulder	32	121-3017	1	Brake Control Module ASM
6	119-3470	2	Actuator Arm ASM	33	117-5385	2	Retainer
6:2	256-156	2	Bushing-Flange	34	32144-1	4	Screw-Taptite
7	110-6810	2	Stud-Damper	35	121-2976	1	Rod-Brake,RH-Wide
8	103-2913	2	Damper-Control, Motion	36	121-2977	1	Rod-Brake,LH-Wide
9	3296-42	8	Nut-Lock, NI	37	117-1169	4	Spring-Compression
10	104-8300	10	Nut-Flange, NI	38	3290-307	2	Pin-Hair
11	3256-23	2	Washer-Flat	39	32144-36	4	Screw-PPH
13	104-8301	4	Nut-Flange, NI	40	1-603807	2	Spring-Return, Neutral
14	119-8925	2	Washer-Belleville	41	119-8859	1	Cover-Brake
15	117-1240	2	Washer	42	32144-4	1	Screw-HWH
16	119-3300	1	Control-Speed	43	93-6079	2	Spacer-Nylon
17	119-3303	2	Pin-Rod, Hydro	44	119-8935	1	RH Knob ASM
19	117-1198	2	Bolt-Pivot	45	119-8936	1	LH Knob ASM
20	119-3387-03	1	Box-Control	46	94-4496	1	Screw-PPH
21	3296-56	2	Nut-Lock, NI	47	3234-47	6	Screw-HHF
22	115-5098-05	2	Lever-Control	48	120-5468	1	Decal-Speed Control
23	120-2273	2	Washer-Nylon	49	32144-70	4	Screw-HWHTF
24	115-9604	2	Eccentric	50	120-5470	1	Decal-HOC
25	119-3301	2	Bolt-Pivot, Eccentric				

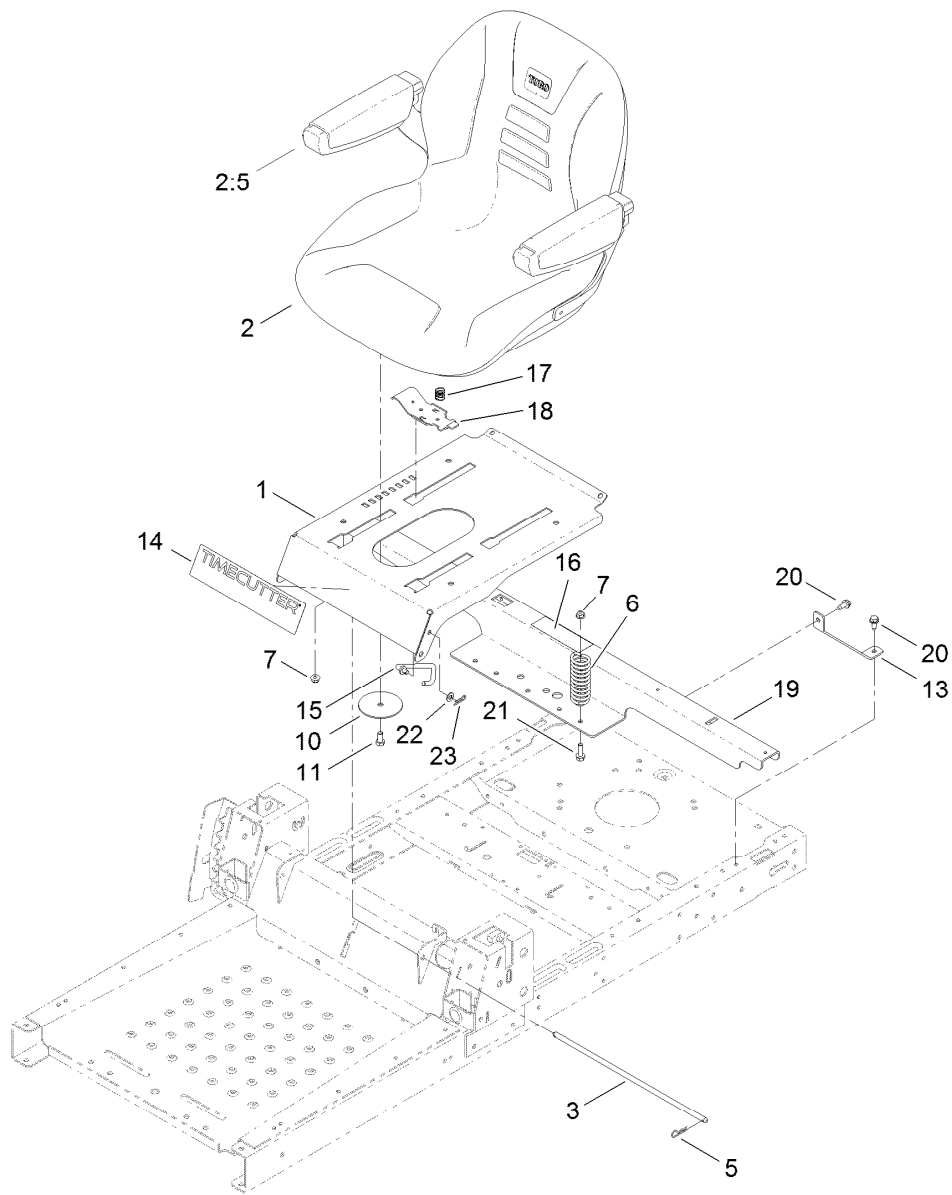

## Seat Assembly

<i>Ref.</i>	<i>Part Number</i>	<i>Qty.</i>	<i>Description</i>	<i>Ref.</i>	<i>Part Number</i>	<i>Qty.</i>	<i>Description</i>
1	119-3390-01	1	Pan-Seat	14	121-3036	1	Decal-Timecutter
2	115-5053	1	18 Inch Seat ASM	15	119-8972	1	Stop-Seat
2:5	119-3307	1	Armrest Kit	16	106-8717	1	Decal-Service
3	115-4966	1	Rod-Stop	17	115-9624	1	Spring-Compression
5	3290-250	2	Pin-Hair	18	115-9623	1	Latch-Seat
6	92-7054	3	Spring-Compression	19	119-3414-03	1	Support-Pod
7	104-8300	3	Nut-Flange, NI	20	32144-70	4	Screw-HWHTF
10	117-5307	1	Washer-Seat	21	3234-29	3	Screw-HHF
11	323-4	1	Screw-HH	22	3256-23	1	Washer-Flat
13	119-3431-03	2	Support-Tank, Rear	23	3290-307	1	Pin-Hair

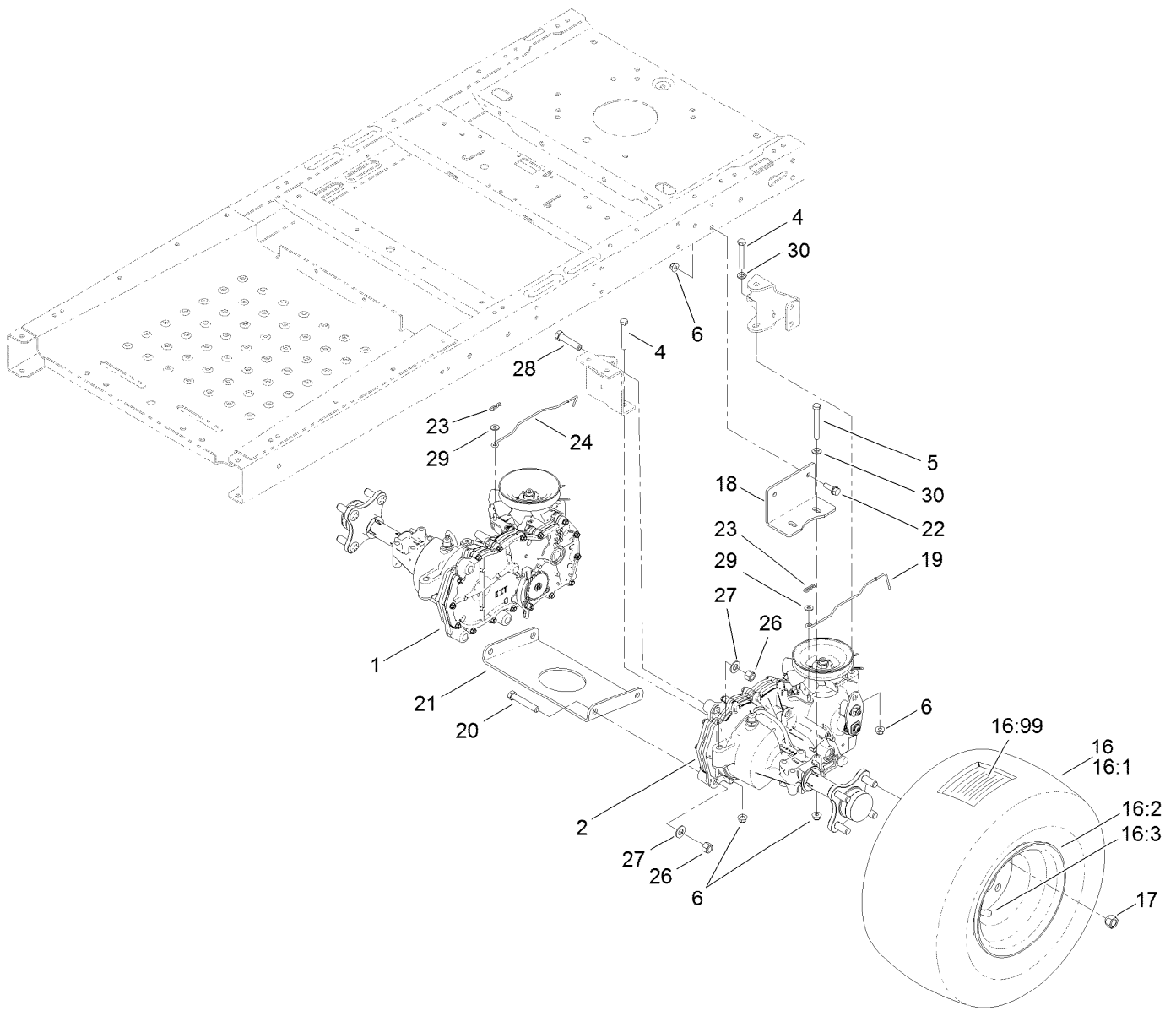

## Hydro Transaxle Assembly

Ref.	Part Number	Qty.	Description	Ref.	Part Number	Qty.	Description
1	119-3351	1	Transaxle-Hydro, RH	19	121-2971	1	Rod-Bypass, LH
2	119-3350	1	Transaxle-Hydro, LH	20	324-10	4	Screw-HH
4	322-11	4	Screw-HH	21	119-3342-03	1	Cross Plate-Hydro
5	322-13	4	Screw-HH	22	3234-29	4	Screw-HHF
6	104-8300	12	Nut-Flange, NI	23	3290-307	2	Pin-Hair
16	119-8908	2	Wheel And Tire ASM	24	121-0752	1	Rod-Bypass, RH
16:1	119-8909	1	Tire	26	3296-48	6	Nut-Lock, NI
16:2	217-60	1	Rim	27	3256-25	6	Washer-Flat
16:3	232-27	1	Stem-Valve	28	324-8	2	Screw-HH
16:99	232-37	1	Tube	29	3256-22	2	Washer-Flat
17	242-50	8	Nut-Lug	30	3256-23	6	Washer-Flat
18	117-7264-03	2	Mount-Hydro				

# RH Hydro Transaxle Assembly No. 119-3351

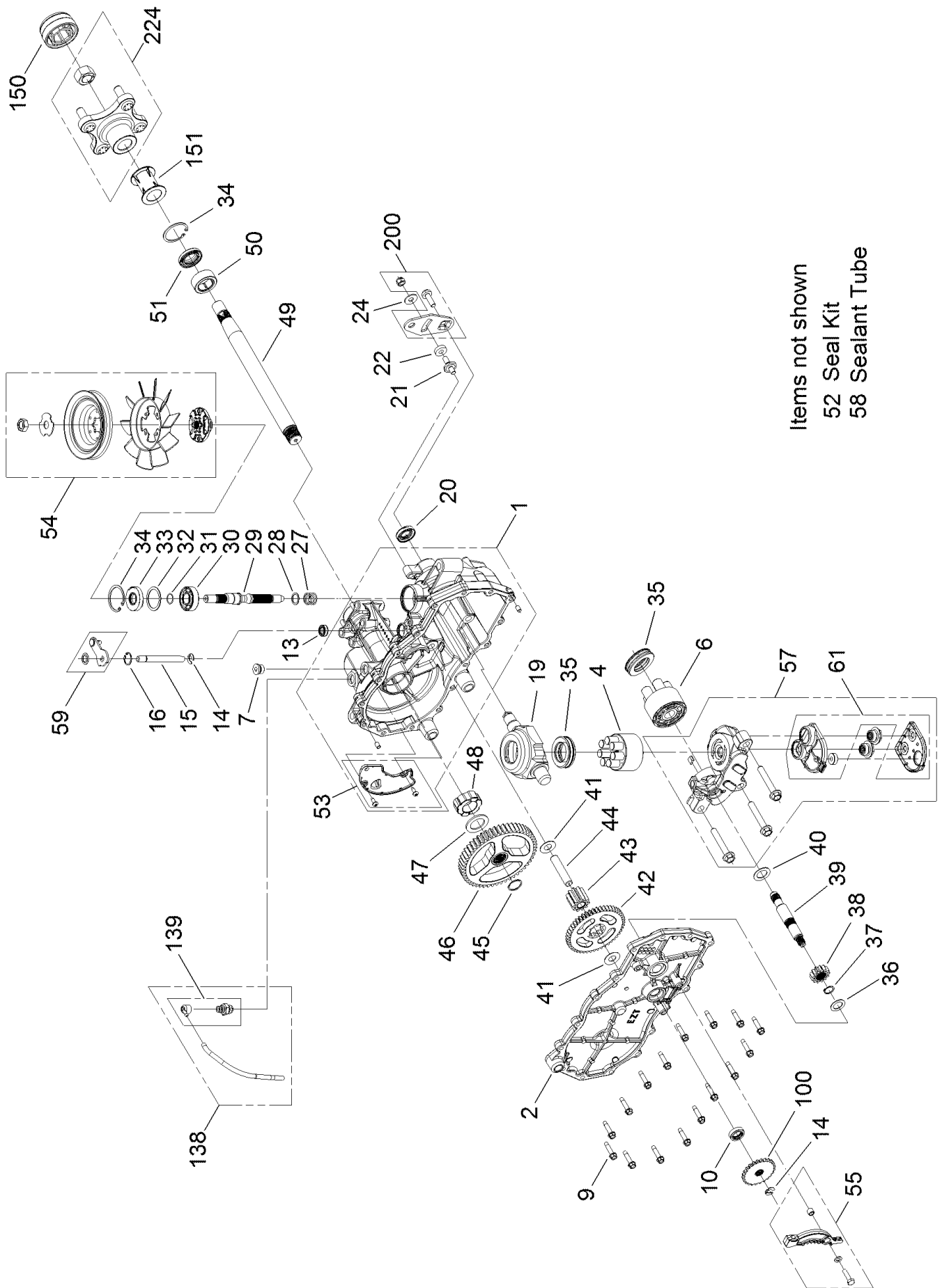

# RH Hydro Transaxle Assembly No. 119-3351 (continued)

<i>Ref.</i>	<i>Part Number</i>	<i>Qty.</i>	<i>Description</i>	<i>Ref.</i>	<i>Part Number</i>	<i>Qty.</i>	<i>Description</i>
1	106-8674	1	Main Housing ASM	39	106-8683	1	Shaft-Motor
2	106-8675	1	Side ASM	40	104-5360	1	Washer-Shaft, Motor
4	110-8561	1	Pump Block ASM	41	119-5541	2	Washer
6	103-2666	1	Cylinder Block Kit	42	104-5317	1	Gear
7	104-2189	1	Plug-Thread, Straight	43	104-5318	1	Gear-Jackshaft, 10T
9	104-5305	16	Screw-HHF	44	104-5329	1	Pin-Jackshaft
10	104-5347	1	Seal-Oil	45	112-9854	1	Ring-Spiral, Retaining
13	106-8676	1	Seal-Lip	46	112-9855	1	Gear-52T, Bull
14	106-8677	1	Ring-Retaining, EXT	47	112-9856	1	Washer
15	106-8678	1	Rod-Bypass	48	112-9857	1	Bearing-Sleeve
16	106-8679	1	Ring-Retaining, Int	49	120-7104	1	Shaft-Axle
19	104-5304	1	Swashplate-Trunnion	50	112-9859	1	Bushing-Axle
20	104-5313	1	Seal-Lip	51	112-9860	1	Seal-Lip
21	104-2116	1	Stud	52	106-8686	1	Seal Kit ●
22	112-9853	1	Puck-Friction	53	106-8687	1	Expansion Plate Kit
24	114-8491	1	Washer	54	120-7105	1	Fan Pulley Kit
27	120-5537	1	Spring-Compression	55	106-8688	1	Brake Arm Kit
28	120-5538	1	Washer	57	112-9862	1	Center Section Filter Kit
29	104-5306	1	Shaft-Input	58	104-2147	1	Sealant ●
30	104-5311	1	Bearing-Ball	59	107-2489	1	Bypass Arm Kit
31	104-5307	1	Ring-Retaining	61	114-1634	1	Filter Kit
32	104-5308	1	Spacer	100	106-8694	1	Disc-Brake, Cog
33	104-5310	1	Seal-Lip	138	112-9866	1	Breather Kit
34	104-5309	1	Ring-Retaining	139	114-1635	1	Breather ASM
35	94-6922	2	Bearing-Thrust	150	115-5057	1	Cover-Nut, Axle
36	104-5339	1	Washer-Flat	151	120-7109	1	Tube-Axle
37	104-5340	1	Ring-Retaining	200	117-5362	1	Arm Control Kit
38	104-5316	1	Gear-Pinion, 13T	224	120-7110	1	Hub ASM

● Not illustrated

# LH Hydro Transaxle Assembly No. 119-3350

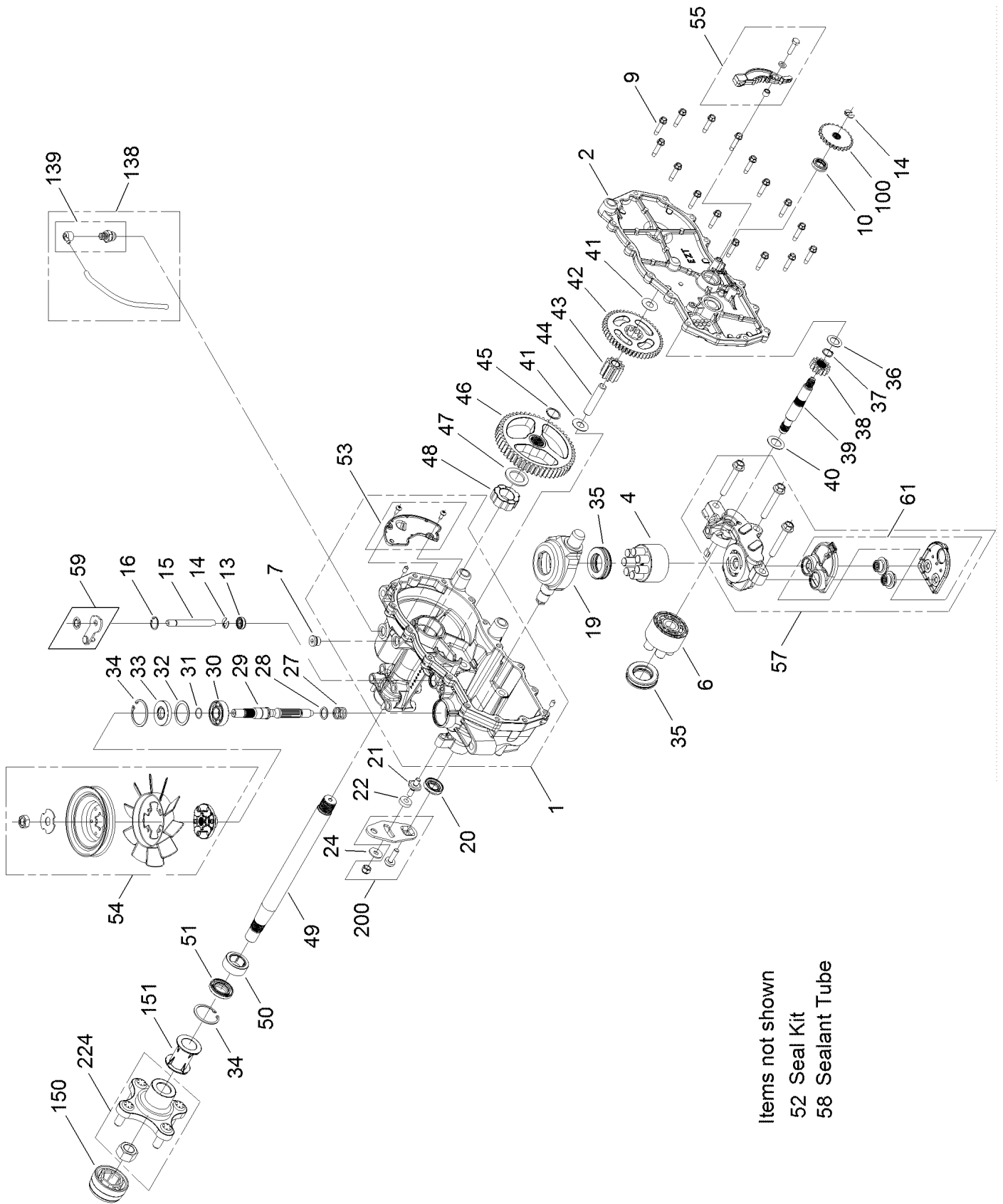

Items not shown  
 52 Seal Kit  
 58 Sealant Tube

# LH Hydro Transaxle Assembly No. 119-3350 (continued)

<i>Ref.</i>	<i>Part Number</i>	<i>Qty.</i>	<i>Description</i>	<i>Ref.</i>	<i>Part Number</i>	<i>Qty.</i>	<i>Description</i>
1	106-8695	1	Main Housing ASM	39	106-8683	1	Shaft-Motor
2	106-8696	1	Side ASM	40	104-5360	1	Washer-Shaft, Motor
4	110-8561	1	Pump Block ASM	41	119-5541	2	Washer
6	103-2666	1	Cylinder Block Kit	42	104-5317	1	Gear
7	104-2189	1	Plug-Thread, Straight	43	104-5318	1	Gear-Jackshaft, 10T
9	104-5305	16	Screw-HHF	44	104-5329	1	Pin-Jackshaft
10	104-5347	1	Seal-Oil	45	112-9854	1	Ring-Spiral, Retaining
13	106-8676	1	Seal-Lip	46	112-9855	1	Gear-52T, Bull
14	106-8677	2	Ring-Retaining, EXT	47	112-9856	1	Washer
15	106-8678	1	Rod-Bypass	48	112-9857	1	Bearing-Sleeve
16	106-8679	1	Ring-Retaining, Int	49	120-7104	1	Shaft-Axle
19	104-5304	1	Swashplate-Trunnion	50	112-9859	1	Bushing-Axle
20	104-5313	1	Seal-Lip	51	112-9860	1	Seal-Lip
21	104-2116	1	Stud	52	106-8686	1	Seal Kit ●
22	112-9853	1	Puck-Friction	53	106-8697	1	Expansion Plate Kit
24	114-8491	1	Washer	54	105-1928	1	Fan Pulley Kit
27	120-5537	1	Spring-Compression	55	106-8688	1	Brake Arm Kit
28	120-5538	1	Washer	57	112-9861	1	Center Section Filter Kit
29	104-5306	1	Shaft-Input	58	104-2147	1	Sealant ●
30	104-5311	1	Bearing-Ball	59	120-5549	1	Bypass Kit
31	104-5307	1	Ring-Retaining	61	114-1634	1	Filter Kit
32	104-5308	1	Spacer	100	106-8694	1	Disc-Brake, Cog
33	104-5310	1	Seal-Lip	138	112-9866	1	Breather Kit
34	104-5309	2	Ring-Retaining	139	114-1635	1	Breather ASM
35	94-6922	2	Bearing-Thrust	150	115-5057	1	Cover-Nut, Axle
36	104-5339	1	Washer-Flat	151	120-7109	1	Tube-Axle
37	104-5340	1	Ring-Retaining	200	117-5362	1	Arm Control Kit
38	104-5316	1	Gear-Pinion, 13T	224	120-7110	1	Hub ASM

● Not illustrated

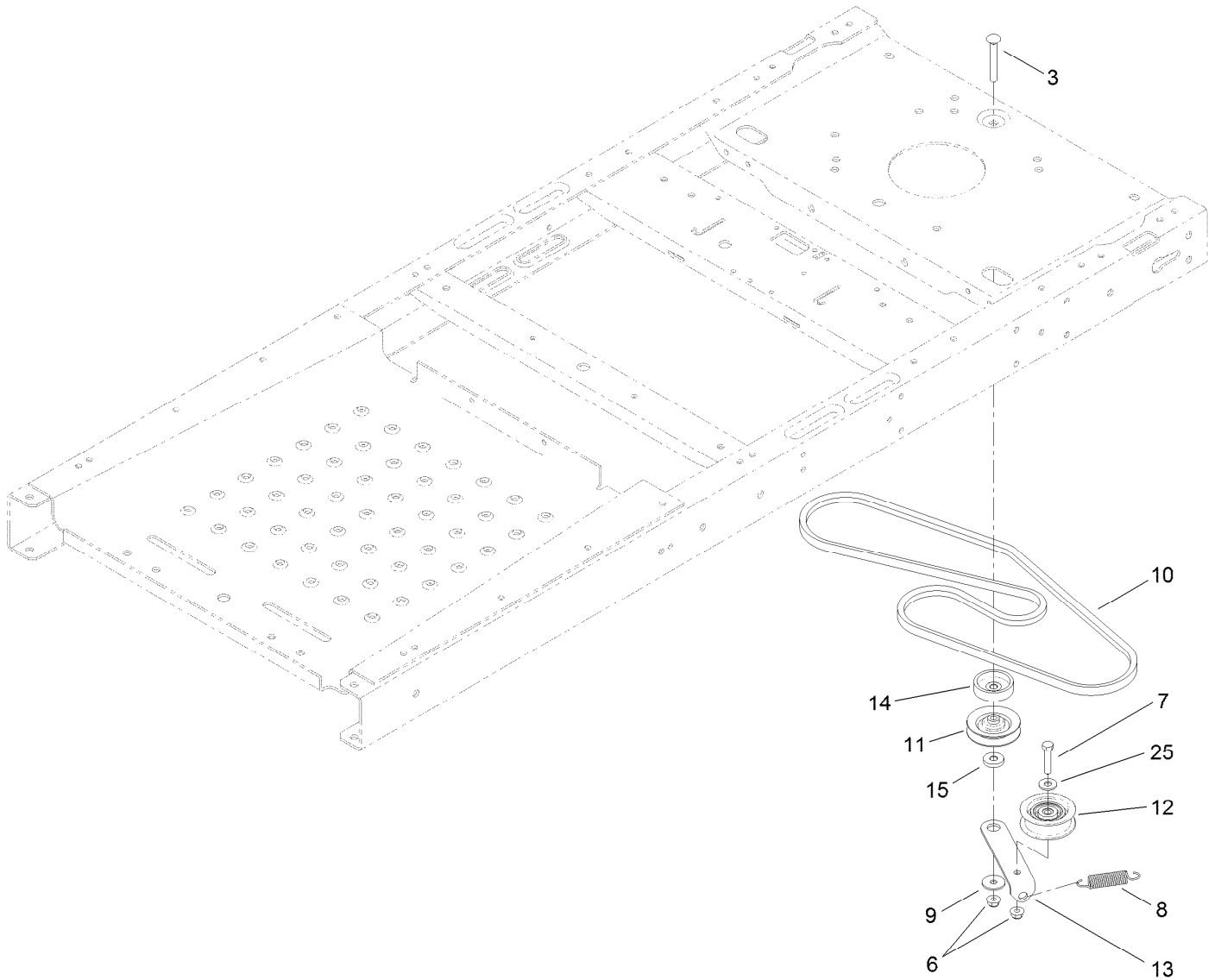

## Belt and Pulley Assembly

<i>Ref.</i>	<i>Part Number</i>	<i>Qty.</i>	<i>Description</i>
3	3230-8	1	Screw-CARR
6	104-8300	2	Nut-Flange, NI
7	322-7	1	Screw-HH
8	104-6415	1	Spring-Return, Pedal
9	5-4460	1	Washer-Pivot
10	119-3321	1	V-Belt
11	119-8822	1	Pulley-Idler
12	106-2176	1	Pulley-Idler
13	119-3326	1	Arm-Idler
14	119-3353	1	Spacer
15	119-3327	1	Spacer-Arm, Idler
25	3256-3	1	Washer-Flat

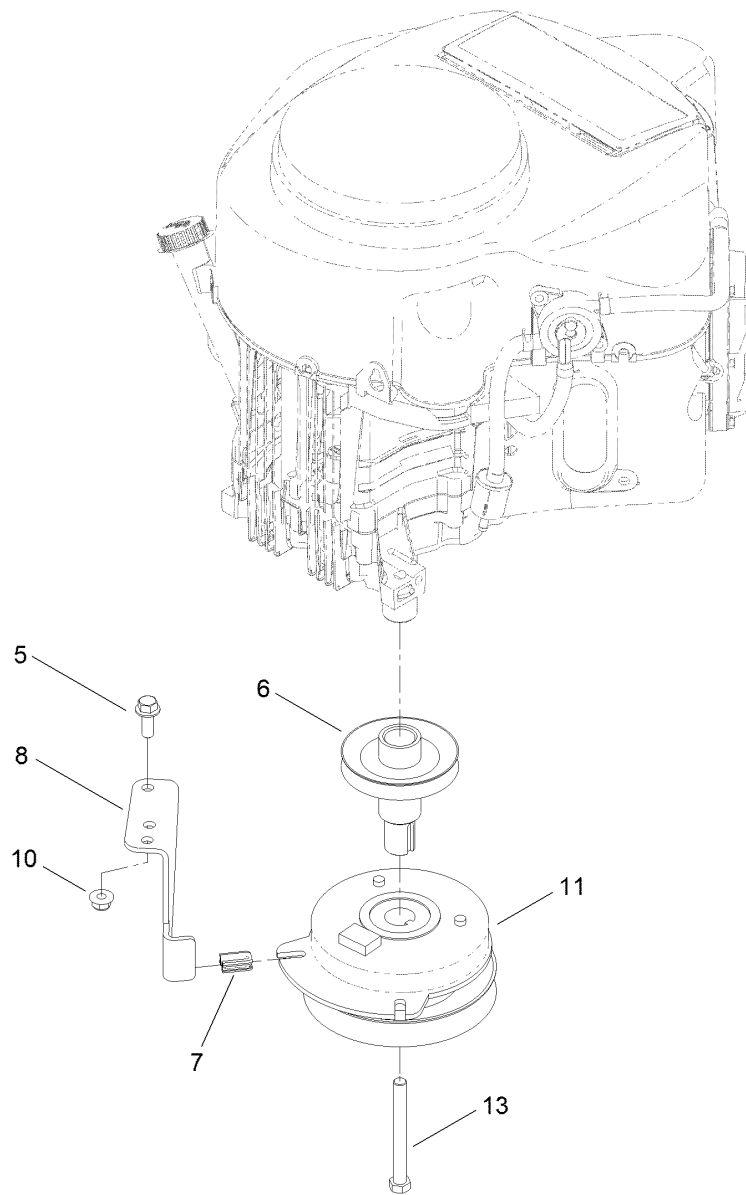

## Clutch Assembly

<b>Ref.</b>	<b>Part Number</b>	<b>Qty.</b>	<b>Description</b>
5	3234-42	1	Screw-HHF
6	119-3318	1	Pulley-Engine
7	120-2217	1	Isolator-Clutch
8	119-8885	1	Stop-Clutch
10	104-8301	1	Nut-Flange, NI
11	110-6766	1	Clutch-Electric, PTO
13	3212-17	1	Screw-HH

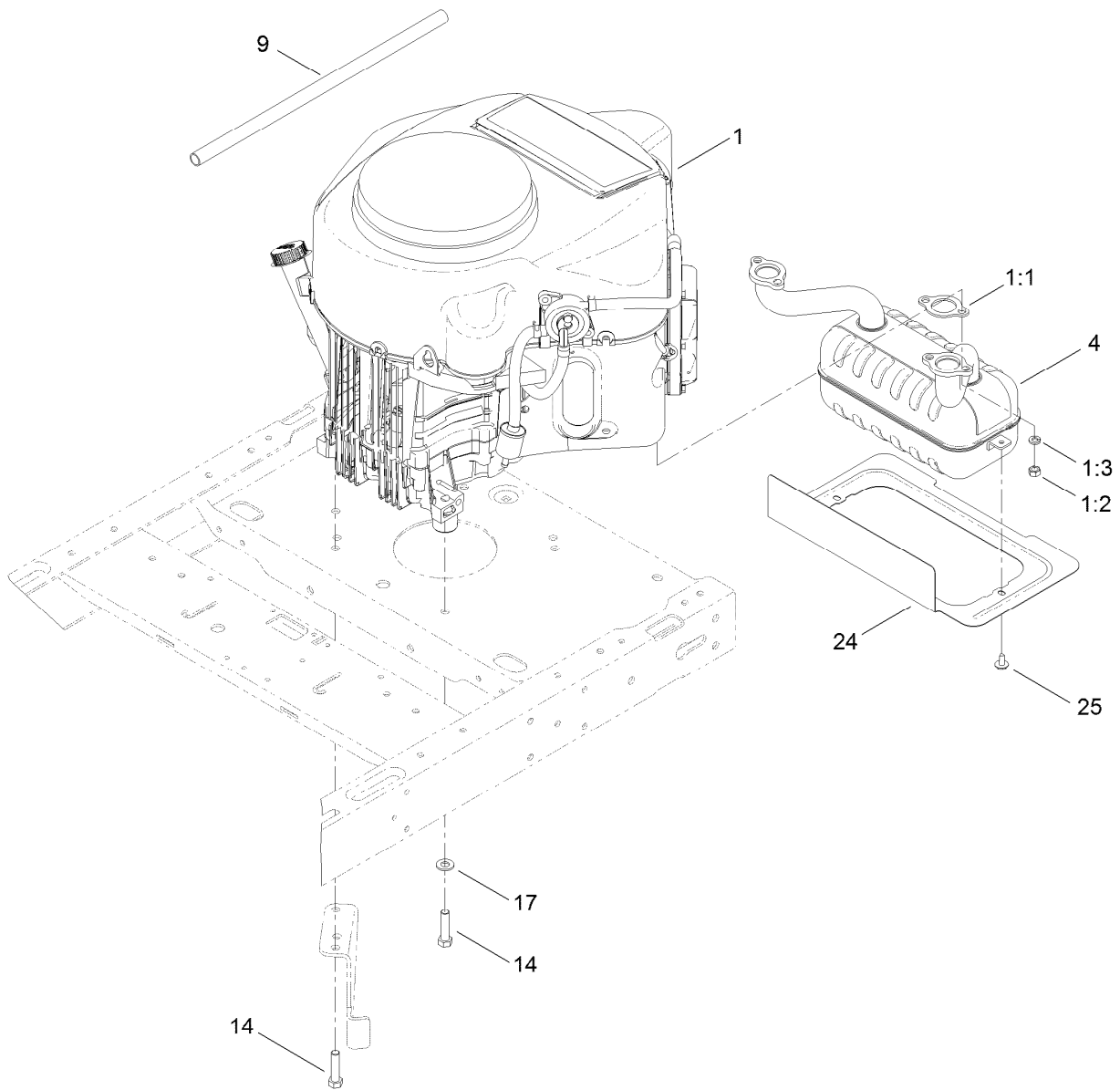

## Engine and Exhaust Assembly

Ref.	Part Number	Qty.	Description
1		1	Engine Kawasaki, Fr691V-_s50-R ●■
1:1	1-653313	2	Gasket-Exhaust
1:2	114-3549	4	Nut
1:3	114-3550	4	Washer-Lock, Spring
4	117-7256	1	Muffler-Kawasaki
9	106-7022	1	Tube-Drain, Oil
14	323-50	4	Bolt-HH
17	3256-24	3	Washer-Flat
24	121-2973-03	1	Shield-Heat
25	46-8560	2	Screw-HHFTF

● Not serviced separately

■ Obtain parts from [www.kawpowerrep.com](http://www.kawpowerrep.com)

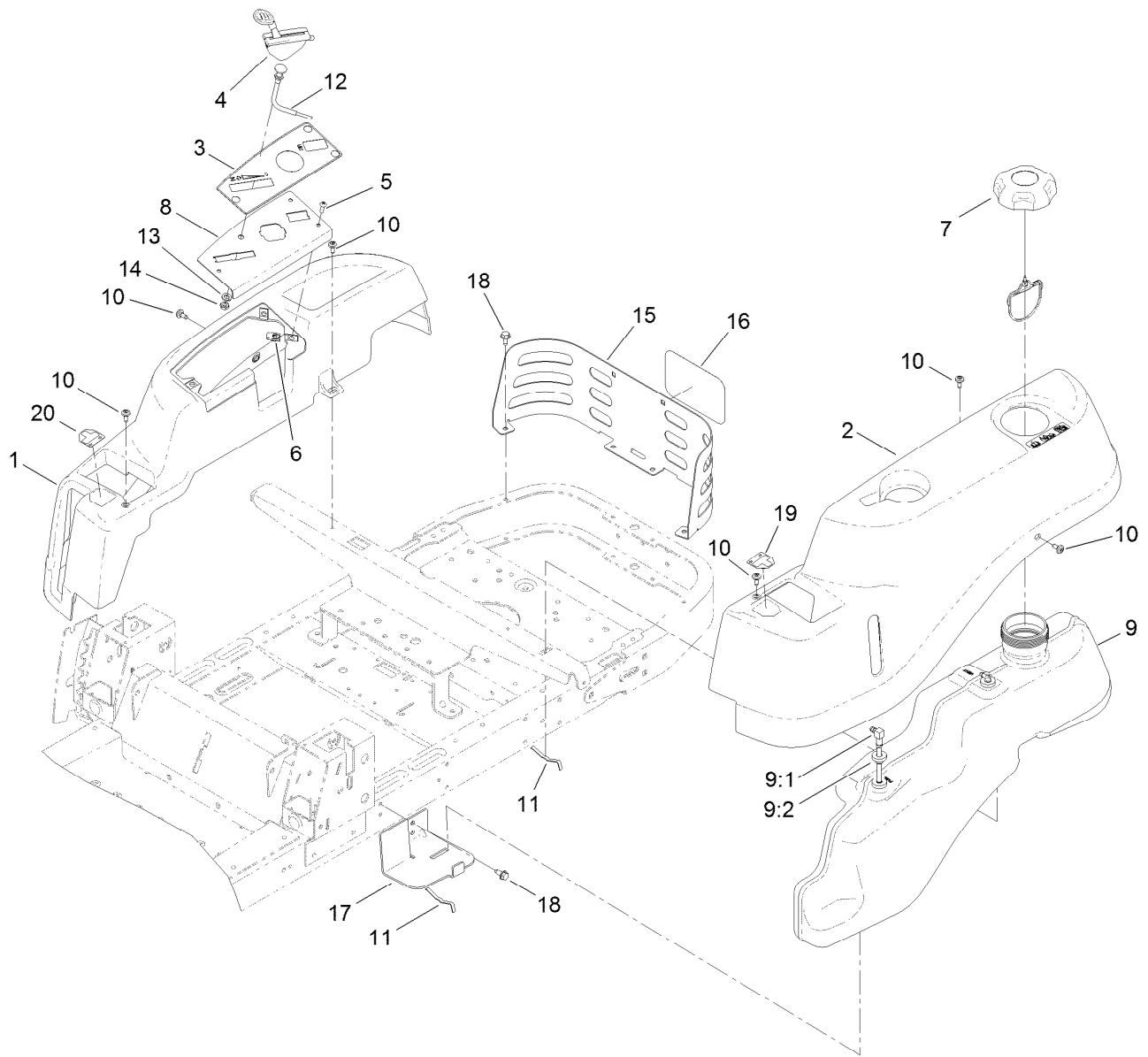

## Body Styling and Fuel Pod Assembly

<i>Ref.</i>	<i>Part Number</i>	<i>Qty.</i>	<i>Description</i>	<i>Ref.</i>	<i>Part Number</i>	<i>Qty.</i>	<i>Description</i>
1	119-3338	1	Pod-RH	10	120-7950	6	Screw-Shoulder
2	119-3337	1	Pod-LH	11	609830	2	Spring
3	121-0773	1	Decal-Panel, Control	12	112-9753	1	Cable-Choke
4	121-0769	1	Cable-Throttle	13	3253-21	1	Washer-Lock
5	3258-166	3	Screw-PRH	14	3220-3	1	Nut-HJ
6	107069	3	Clip	15	119-3304-03	1	Guard-Rear
7	120-5461	1	Cap-Fuel, Ratcheting	16	99-4693	1	Decal
8	119-3377-03	1	Plate-Control	17	119-3395-03	1	Support-Tank, Front
9	119-3324	1	Fuel Tank ASM	18	32144-70	6	Screw-HWHTF
9:1	121-0793	1	Connector-Elbow, 90 DEG	19	119-8814	1	Decal-Control Lever, LH
9:2	46-6560	2	Bushing	20	119-8815	1	Decal-Control Lever, RH

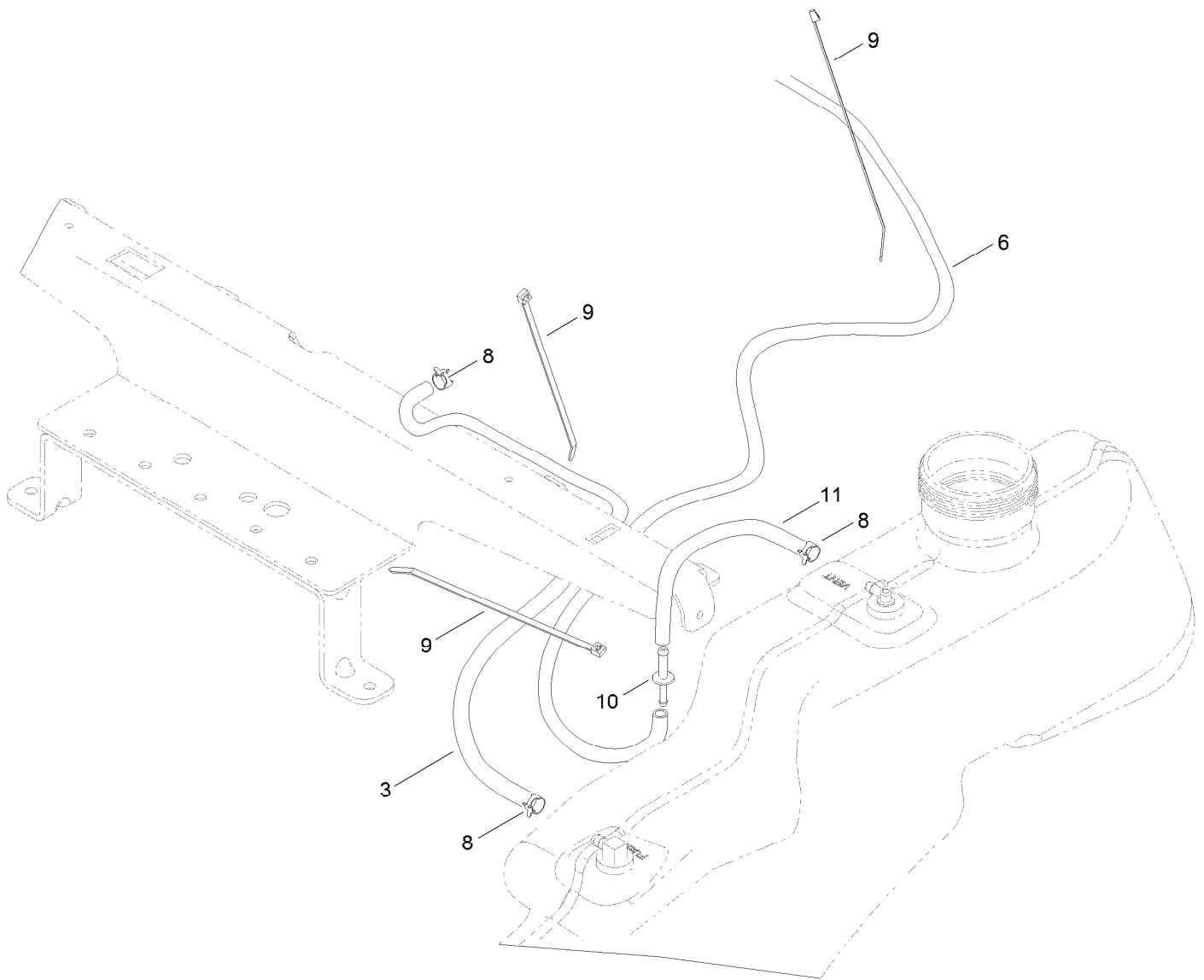

## Fuel Delivery Assembly

<i>Ref.</i>	<i>Part Number</i>	<i>Qty.</i>	<i>Description</i>
3	110-5701	1	Hose-Fuel
6	51-3212	1	Hose-Fuel
8	2412-98	3	Clamp-Hose
9	614249	3	Tie-Cable
10	117-5399	1	Adaptor-Orifice
11	110-1876	1	Hose-Fuel



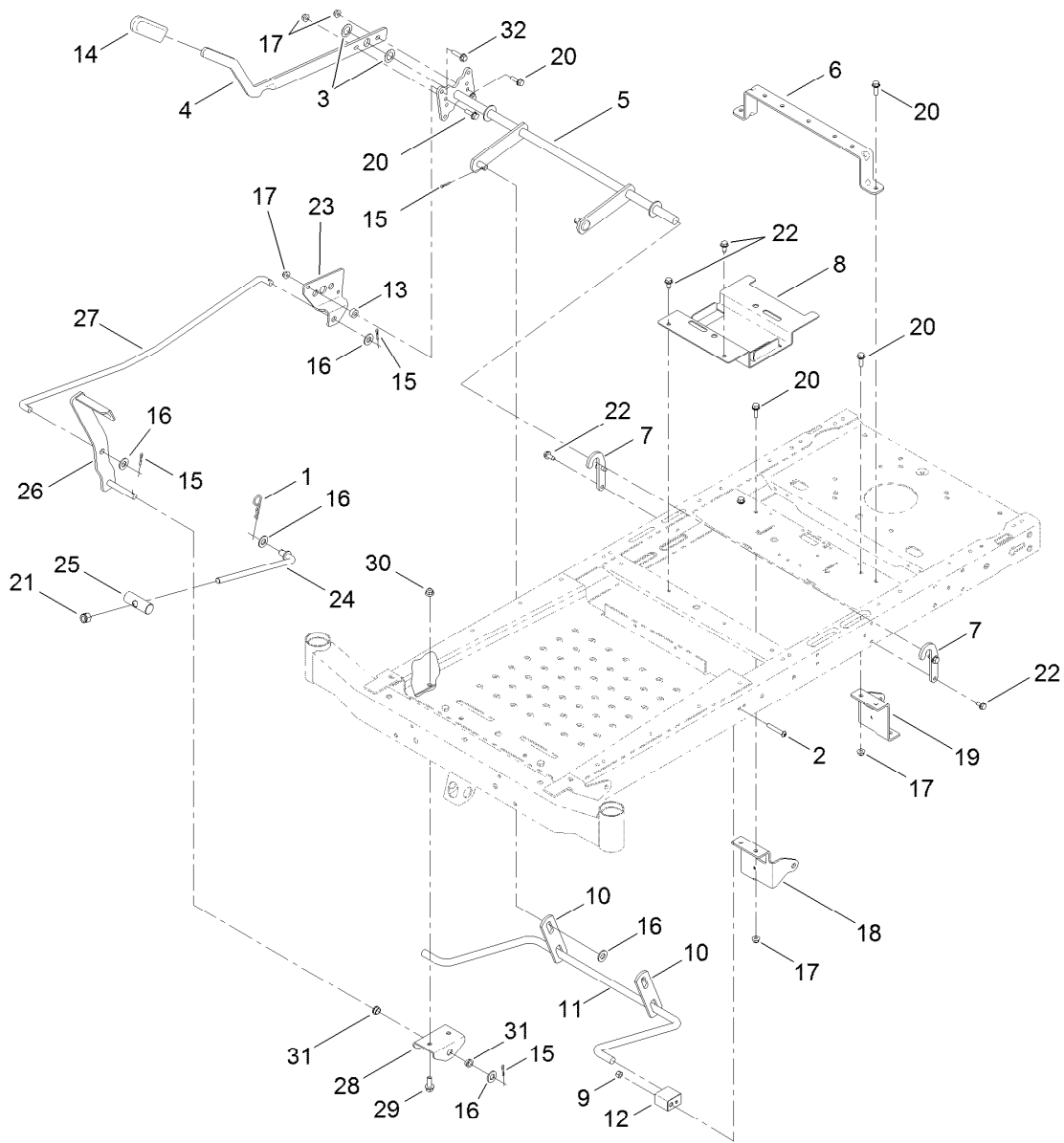

## Deck Lift Assembly

Ref.	Part Number	Qty.	Description
1	1-806005	1	Pin-Hair
2	120-5499	2	Screw-HSBH
3	3-6498	2	Washer-Thrust
4	119-3427-03	1	Lever-Lift
5	119-3424-03	1	Deck Lift ASM
6	117-7337-03	1	Brace-Seat, Rear
7	119-8875	2	Bracket-Lift
8	119-3406-03	1	Bracket-Battery
9	3296-29	2	Nut-Lock, NI
10	108-7840	2	Link-Lift
11	119-3347	1	Arm-Lift, Rear
12	108-7845	2	Block-Pivot
13	112-3961	2	Spacer
14	1-633268	1	Grip-Lever
15	3272-10	5	Pin-Cotter
16	3256-26	6	Washer-Flat

Ref.	Part Number	Qty.	Description
17	104-8300	6	Nut-Flange, NI
18	119-8861-01	1	Mount-Hydro, Front RH
19	119-8862-01	1	Mount-Hydro, Front LH
20	3234-29	4	Screw-HHF
21	3296-19	1	Nut-Hex
22	32144-70	6	Screw-HWHTF
23	120-2275	1	Plate-Footlift
24	104-8047	1	Rod-Trunion
25	119-8810	1	Pin-Pivot
26	120-2276-03	1	Pedal ASM
27	120-2242	1	Rod-Footlift
28	120-2294-03	1	Bracket-Footlift
29	3234-42	2	Screw-HHF
30	104-8301	2	Nut-Flange, NI
31	256-156	2	Bushing-Flange
32	3234-36	2	Screw-HHF

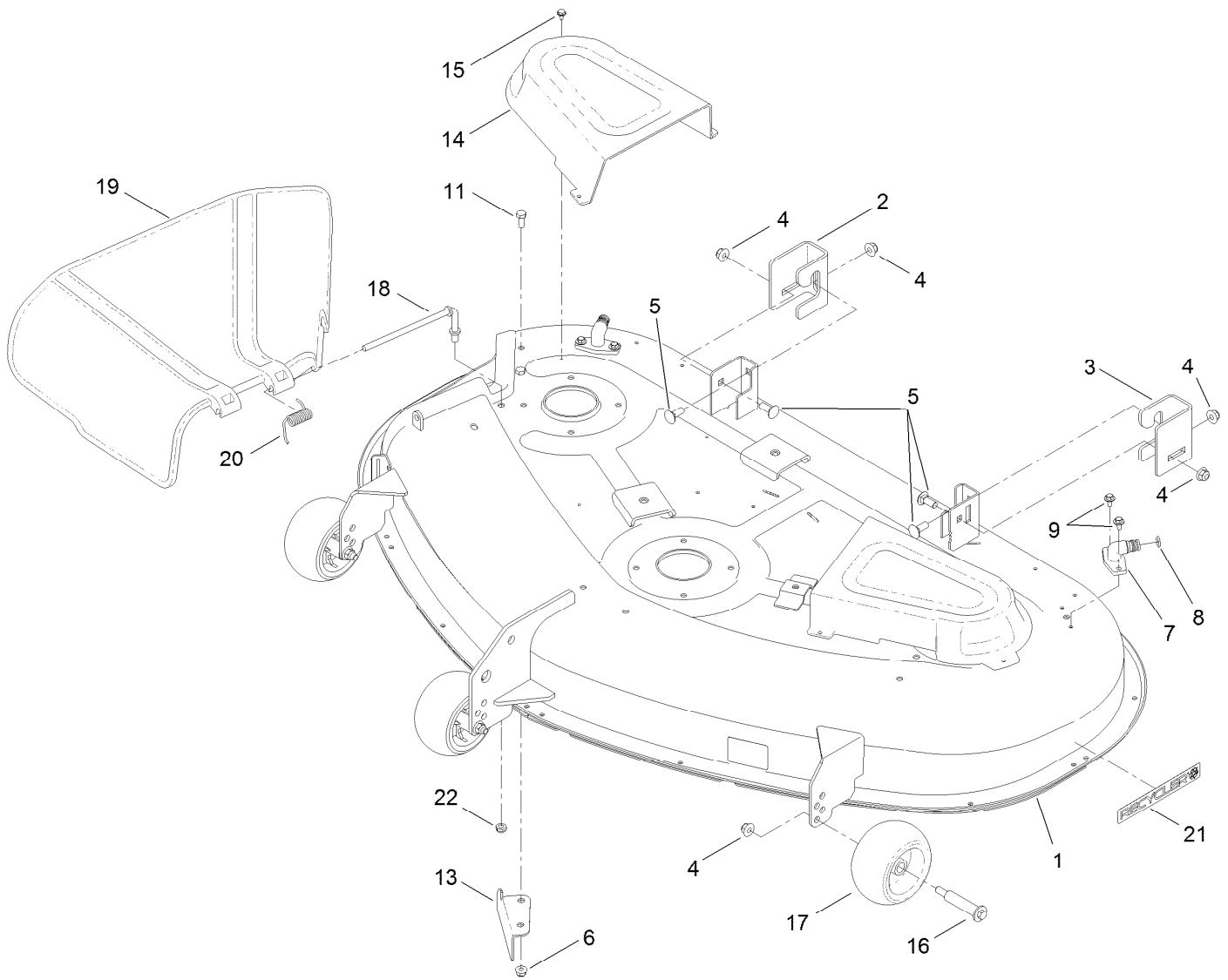

## 50 Inch Deck Assembly

Ref.	Part Number	Qty.	Description	Ref.	Part Number	Qty.	Description
1	119-8841	1	50 Inch Deck And Decal ASM	13	112-3983-03	1	Baffle-Cutoff
2	119-3494	1	Bracket-Hanger, RH	14	108-7890	2	Cover-Belt
3	119-3496	1	Bracket-Hanger, LH	15	32104-76	6	Screw
4	104-8301	7	Nut-Flange, NI	16	112-3977	3	Bolt-Shoulder
5	3231-2	4	Screw-CARR	17	1-603299	3	Roller-Scalp, Anti
6	104-8300	2	Nut-Flange, NI	18	112-3950	1	Rod-Pivot
7	95-2747	2	Fitting-Washout	19	108-7895	1	Deflector
8	46-6290	2	O-Ring, Seal	20	110-6694	1	Spring-Torsion
9	46-8560	4	Screw-HHFTF	21	119-2368	1	Decal-Recycler
11	322-3	2	Screw-HH	22	3296-59	1	Nut-Lock, NI

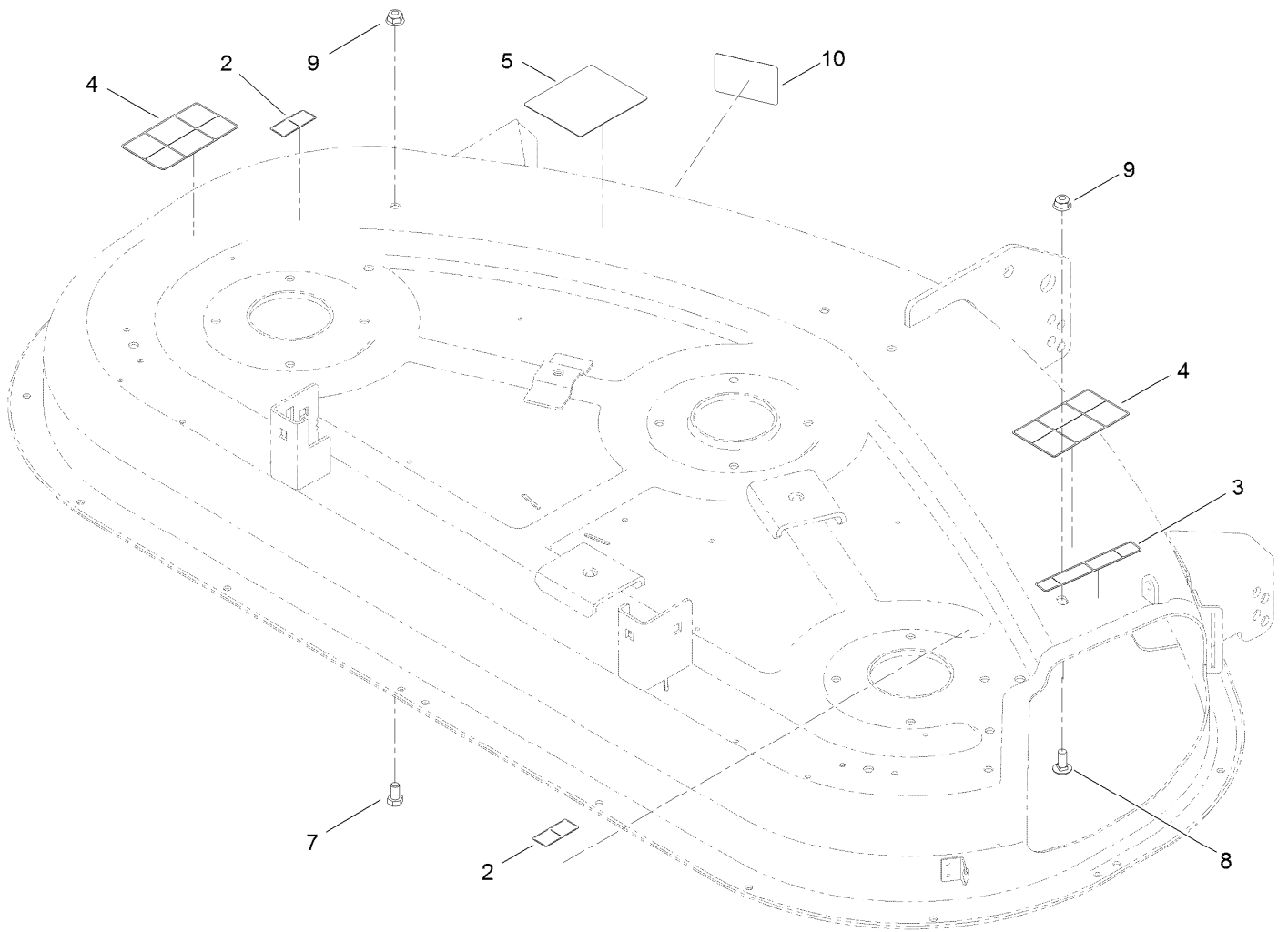

## 50 Inch Deck Decal Assembly No. 119-8841

<i>Ref.</i>	<i>Part Number</i>	<i>Qty.</i>	<i>Description</i>
2	114-1606	2	Decal-Danger, Pulley
3	93-7009	1	Decal-Danger, Deflector
4	110-6691	2	Decal-Danger
5	99-3943	1	Decal-Routing, Belt
7	322-2	1	Screw-HH
8	3230-23	1	Screw-CARR
9	104-8300	2	Nut-Flange, NI
10	112-9840	1	Decal-Scalp, Anti

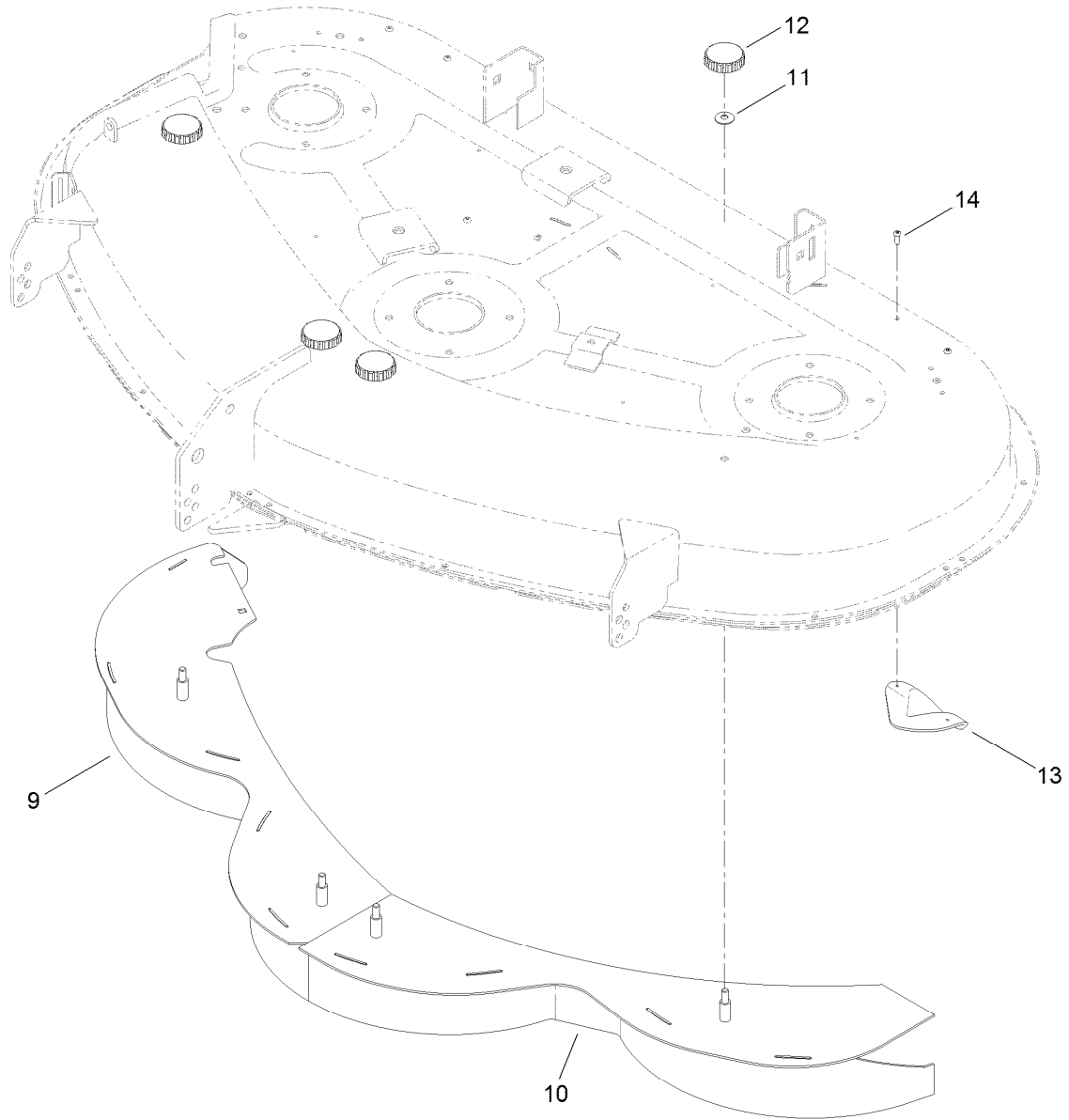

## 50 Inch Deck Baffle Assembly

<i>Ref.</i>	<i>Part Number</i>	<i>Qty.</i>	<i>Description</i>
9	112-4010-03	1	RH Baffle ASM
10	112-4011-03	1	LH Baffle ASM
11	3290-456	4	Washer-Belleville
12	94-5583	4	Knob
13	76-2160	3	Plate-Kicker
14	32144-111	6	Screw-PPH

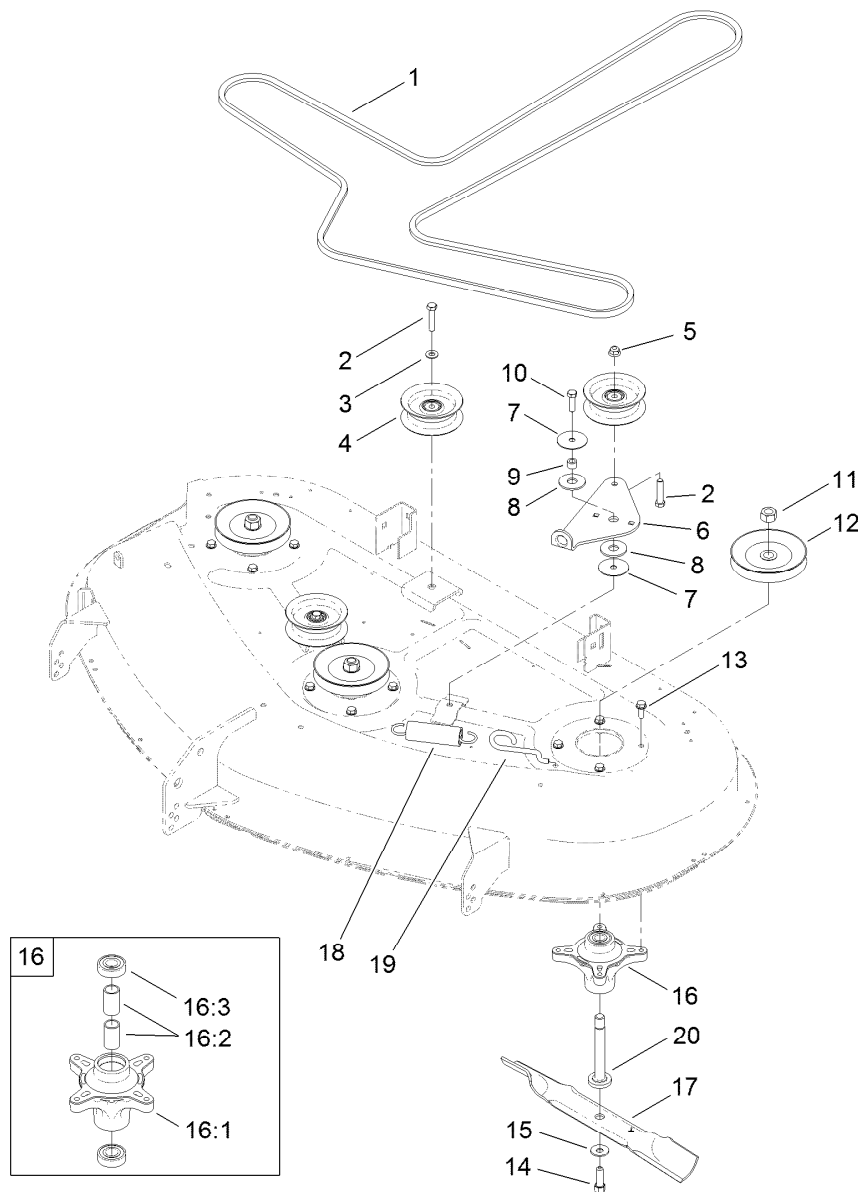

## 50 Inch Deck, Belt and Mulch Blade Assembly

Ref.	Part Number	Qty.	Description	Ref.	Part Number	Qty.	Description
1	119-8820	1	V-Belt	13	32144-41	12	Screw-Taptite
2	323-9	3	Screw-HH	14	26-0671	3	Screw-HH
3	3256-24	2	Washer-Flat	15	3290-465	3	Washer-Belleville
4	106-2175	3	Pulley-Idler, Flat	16	121-0751	3	Spindle ASM
5	104-8301	1	Nut-Flange, NI	16:1	117-7267	1	Spindle
6	114-8540	1	Arm-Idler	16:2	120-7935	2	Spacer
7	120-2229	2	Washer-Idler Pivot	16:3	100-1048	2	Bearing-Ball
8	114-0463	2	Washer-Friction, Composite	17	115-5062-03	3	Blade-Mulch, 17.50 Inch
9	115-4986	1	Spacer	18	1-603414	1	Spring-Extension
10	323-7	1	Screw-HH	19	112-3973	1	Hook-Return, Spring
11	3219-6	3	Nut-Hex	20	117-7268	3	Shaft-Spindle
12	110-6865	3	Pulley				

# Attachments and Accessories

## For 74387 TimeCutter ZS 5000 Riding Mower

<b>Product Name</b>	<b>Model/Part</b>
Deck Ring Kit .....	114-1608
Hourmeter Kit, 2011 and After TimeCutter Riding Mower .....	120-5498
Striping Kit, 42in and 50in Mowers .....	120-7905
Storage Cover (Waterproof, vented and abrasion/tear resistant) .....	490-7516
Sunshade Kit, 2011 and After Zero-Turn-Radius Riding Mower .....	79011
Hitch Kit .....	79014
Replacement Blade Kit (used with Bagger Kit 79335), 2007 and After TimeCutter Riding Mower with 50in Mower .....	79016
50in Bagger, 2011 and After TimeCutter 5000 Series Riding Mower .....	79335
10 cu. ft. Poly Dump Cart .....	79991

**Notes:**

**Notes:**



**Count on it.**