



Count on it.

Parts Catalog

**TimeCutter® ZS 4200TF Riding
Mower**

Model No. 74390—Serial No. 312000001 and Up



Ordering Replacement Parts

To order replacement parts, please supply the part number, the quantity, and the description of each part desired.

Understanding Reference Numbers

Each identified part in an illustration has a reference number. The reference number for a part also appears in the parts list, along with other information about the part.

This catalog uses two special reference number formats, one to indicate parts in a service assembly and another to indicate the quantity of a given part in an illustration.

Service Assembly Reference Numbers

Parts in service assemblies have reference numbers in the form a:b. The a represents the reference number of the entire service assembly and the b represents a sequential number unique to each part within the service assembly.

For example, a wheel assembly might be identified by reference number 6, the tire by 6:1, the valve by 6:2, and the wheel by 6:3. When you order the assembly identified by reference number 6, you receive all parts identified by reference numbers 6:1, 6:2, and 6:3. However, you may also order any part individually. Reference numbers of this type appear in illustration and in parts lists.

Reference Numbers Indicating Quantity

In an illustration, if a reference number indicates more than one part, the reference number has the form nX y. The n represents the quantity of the part, the X is the multiplication symbol, and the y represents the reference number.

For example, in an illustration, the reference number 2X 37 means that two of the parts identified by reference number 37 are indicated.

List of Abbreviations

AR: as required

ASM: assembly

BBC: blade brake control

BHTF: button head thread forming

CARR: carriage

CCW: counter clockwise

CW: clockwise

DEG: degrees

DPA: Dual Point Adjustment

ECM: electronic control module

EXT: external

FH: flat head

GA: gauge

HD: heavy-duty

HF: hex flange

HH: hex head

HHF: hex head flange

HHFTF: hex head flange thread forming

HJ: hex jam

HLH: hex lag head

HOC: height-of-cut

HSBH: hex socket button head

HSFH: hex socket flat head

HSH: hex socket head

HWH: hex washer head

HWTF: hex washer head thread forming

HYD: hydraulic

LH: left hand

LPG: Liquid Propane Gas

NI: nylon insert

NPTF: national pipe thread fine

PFH: phillips flat head

PPH: phillips pan head

PPHTF: phillips pan head thread forming

PRH: phillips round head

PTH: phillips truss head

PTO: power-take-off

RH: right hand

ROPS: roll-over protection system

RRB: rear roller brush

SFH: slotted fillister head

SHH: slotted hex head

SHWH: slotted hex washer head

SPH: slotted pan head

SQH: square head

SRH: slotted round head

STD: standard

TAP: self tapping

TTH: torx truss head

Contents

Main Frame and Front Axle Assembly	4
Caster Wheel Assembly No. 120-5515.....	5
Deck Lift Assembly.....	6
Seat Assembly	7
Motion Control Assembly	8
Belt and Idler Assembly.....	10
Hydro Transaxle Assembly.....	11
Clutch Assembly.....	12
Engine and Muffler Assembly.....	13
Body Styling and Fuel Pod Assembly.....	14
Fuel Delivery Assembly.....	15
Battery and Electrical Assembly.....	16
42 Inch Deck Assembly.....	17
42 Inch Deck and Decal Assembly No. 121-0733.....	18
42 Inch Deck Baffle Assembly	19
42 Inch Deck Belt and Blade Assembly	20
Attachments and Accessories	21

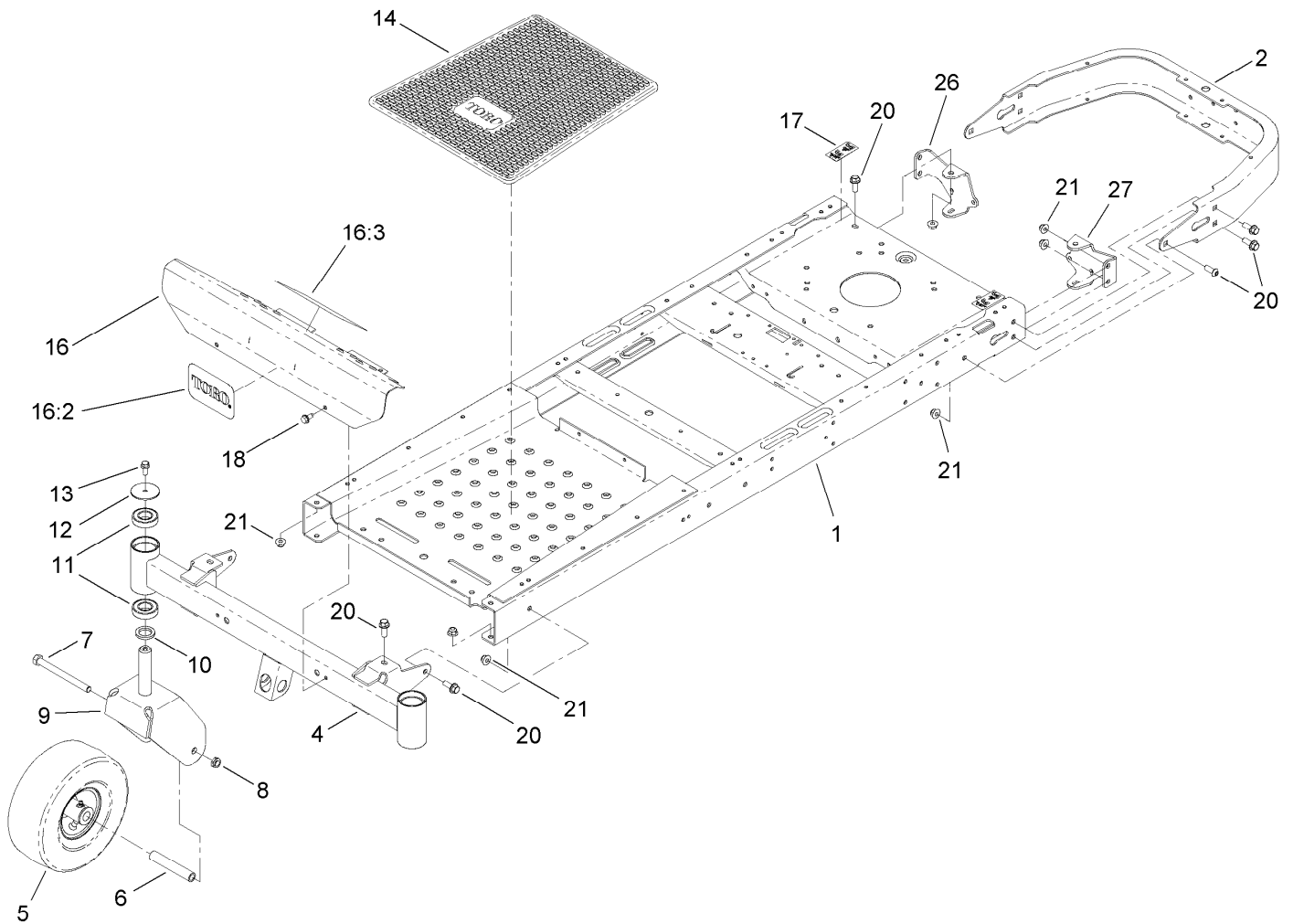

Main Frame and Front Axle Assembly

<i>Ref.</i>	<i>Part Number</i>	<i>Qty.</i>	<i>Description</i>	<i>Ref.</i>	<i>Part Number</i>	<i>Qty.</i>	<i>Description</i>
1	121-2970-01	1	Frame ASM	13	3234-47	2	Screw-HHF
2	110-1920-01	1	Bumper-Rear	14	120-5455	1	Mat-Floor
4	120-5516-01	1	Axle-Front	16	125-0072	1	Footrest ASM
5	120-5515	2	Caster Wheel ASM	16:2	105-8278	1	Decal
6	104-3667	2	Spanner-Wheel	16:3	120-2239	1	Decal-Danger
7	325-22	2	Screw-HH	17	121-2989	2	Decal-Bypass
8	3296-45	2	Nut-Lock, NI	18	32144-70	2	Screw-HWHTF
9	120-2266-01	2	Fork-Caster	20	3234-42	14	Screw-HHF
10	117-7394	2	Washer-Thrust	21	104-8301	14	Nut-Flange, NI
11	109-3678	4	Bearing-Ball	26	121-0737-01	1	Mount-Hydro, Rear RH
12	119-8915	2	Washer	27	121-0738-01	1	Mount-Hydro, Rear LH

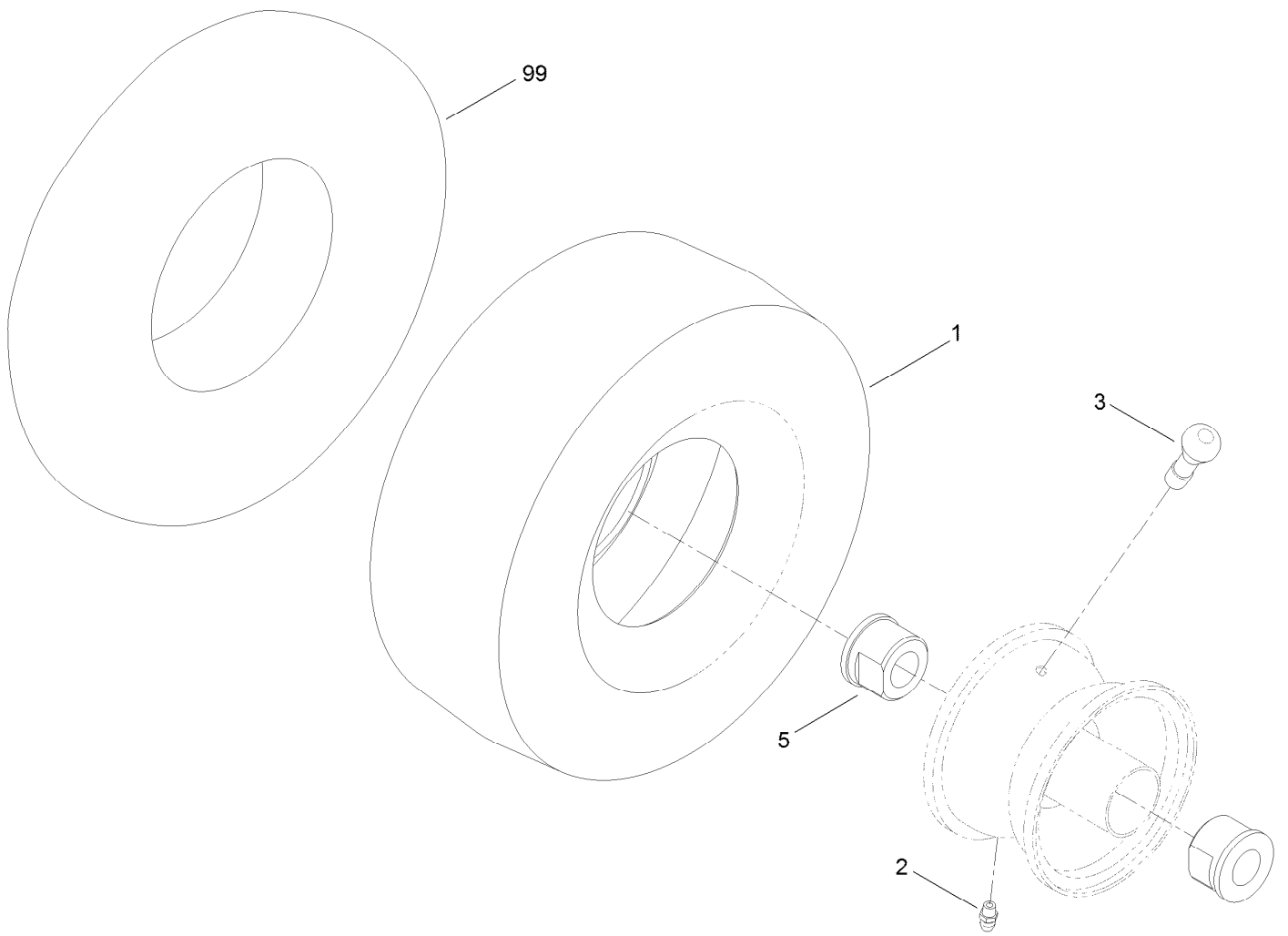

Caster Wheel Assembly No. 120-5515

<i>Ref.</i>	<i>Part Number</i>	<i>Qty.</i>	<i>Description</i>
1	120-5514	1	Tire-Smooth (Cst)
2	302-5	1	Fitting-Grease
3	232-27	1	Stem-Valve
5	114-1640	2	Bushing-Flange
99	93-4244	1	Tube-Inner (W/Valve)

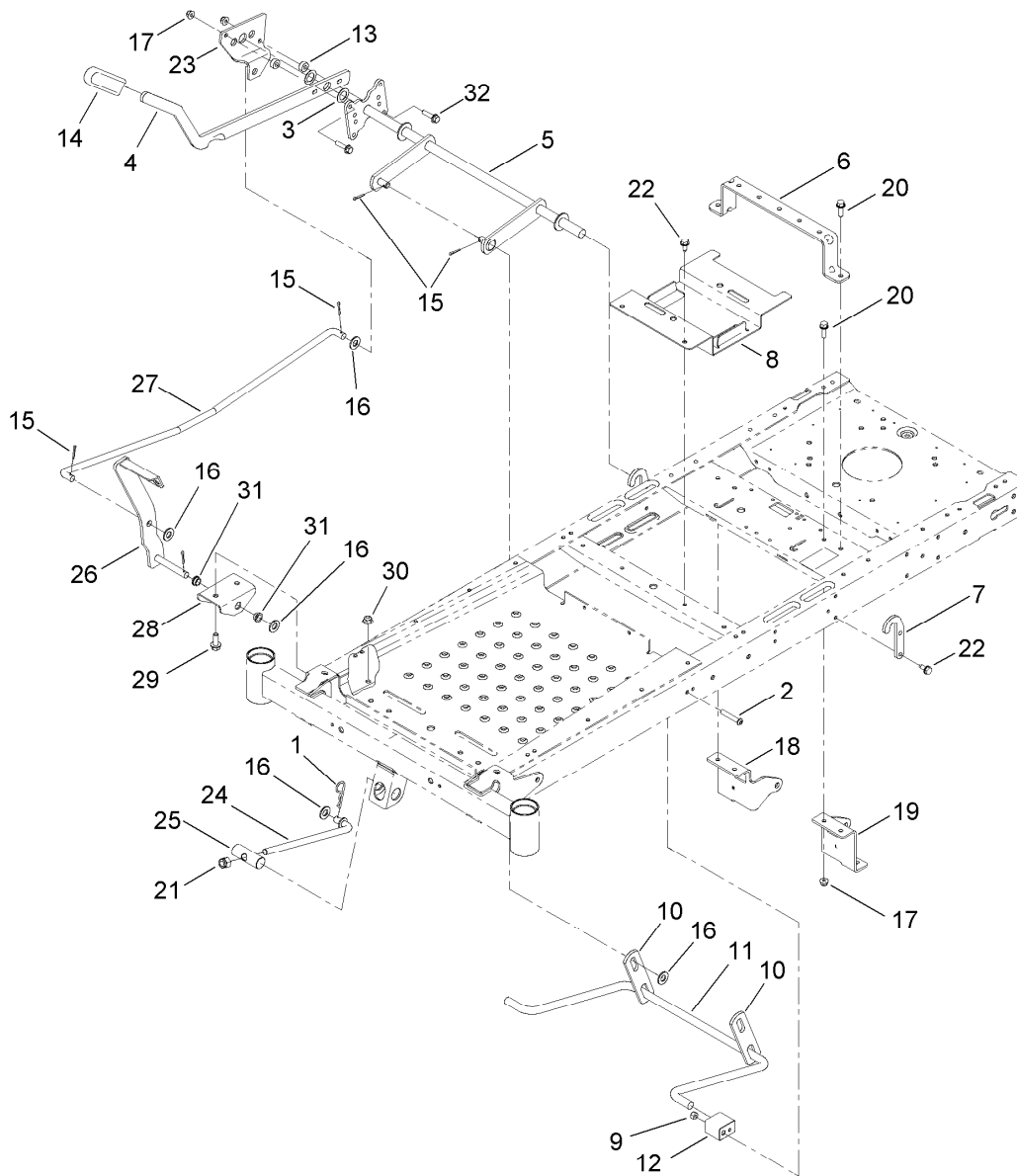

Deck Lift Assembly

Ref.	Part Number	Qty.	Description	Ref.	Part Number	Qty.	Description
1	1-806005	1	Pin-Hair	17	104-8300	6	Nut-Flange, NI
2	120-5499	2	Screw-HSBH	18	119-8861-01	1	Mount-Hydro, Front RH
3	3-6498	2	Washer-Thrust	19	119-8862-01	1	Mount-Hydro, Front LH
4	119-3427-03	1	Lever-Lift	20	3234-29	4	Screw-HHF
5	117-7346-03	1	Deck Lift ASM	21	3296-19	1	Nut-Hex
6	119-3435-03	1	Brace-Seat, Rear	22	32144-70	6	Screw-HWHTF
7	119-8875	2	Bracket-Lift	23	120-2275	1	Plate-Footlift
8	119-3406-03	1	Bracket-Battery	24	104-8047	1	Rod-Trunion
9	3296-29	2	Nut-Lock, NI	25	119-8810	1	Pin-Pivot
10	108-7840	2	Link-Lift	26	120-2276-03	1	Pedal ASM
11	108-7839	1	Arm-Lift, Rear	27	120-2242	1	Rod-Footlift
12	108-7845	2	Block-Pivot	28	120-2294-03	1	Bracket-Footlift
13	121-1759	2	Spacer	29	3234-42	2	Screw-HHF
14	1-633268	1	Grip-Lever	30	104-8301	2	Nut-Flange, NI
15	3272-10	5	Pin-Cotter	31	256-156	2	Bushing-Flange
16	3256-26	6	Washer-Flat	32	3234-36	2	Screw-HHF

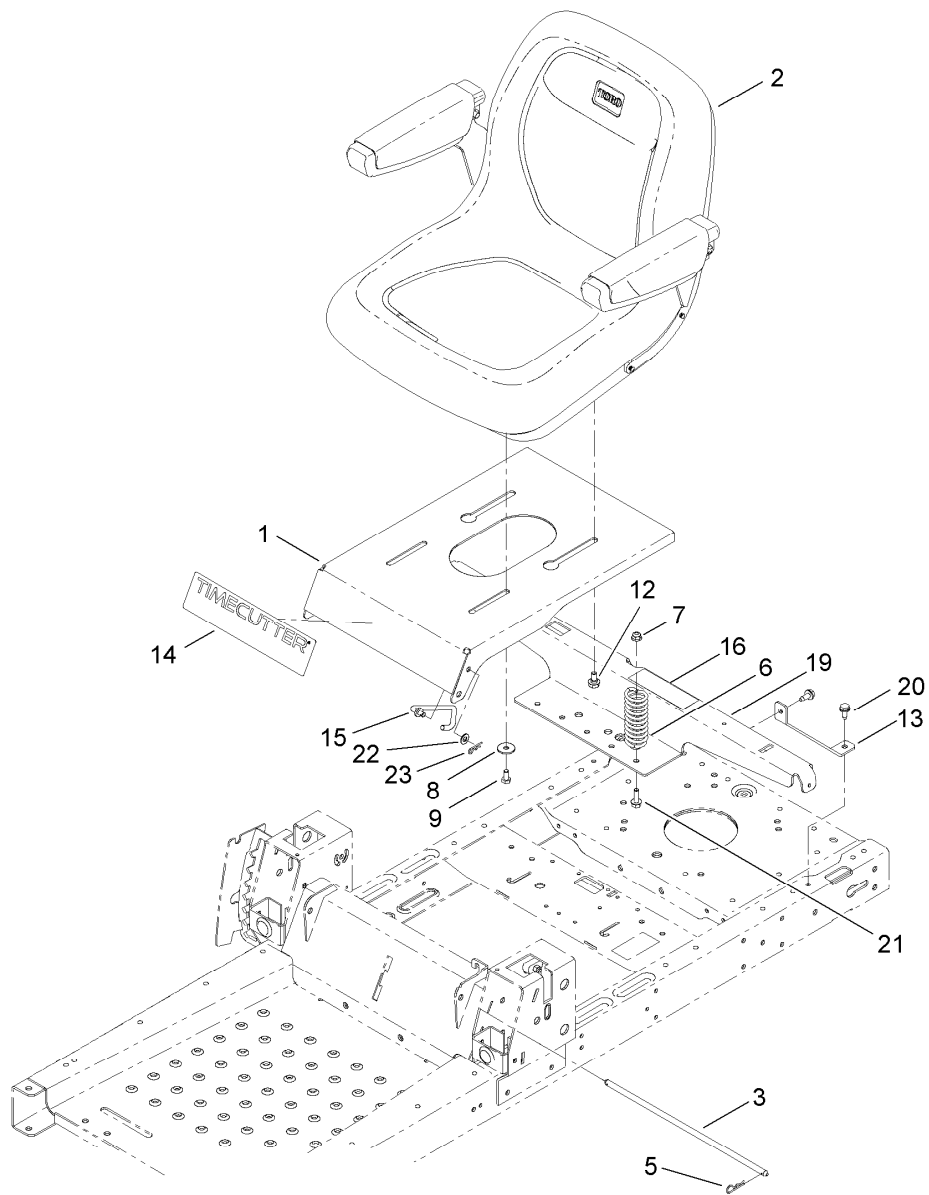

Seat Assembly

<i>Ref.</i>	<i>Part Number</i>	<i>Qty.</i>	<i>Description</i>	<i>Ref.</i>	<i>Part Number</i>	<i>Qty.</i>	<i>Description</i>
1	119-3391-01	1	Pan-Seat	13	119-3431-03	2	Support-Tank, Rear
2	119-8830	1	Seat-18 In	14	121-3035	1	Decal-Timecutter
3	119-3433	1	Rod-Pivot, Narrow	15	119-8972	1	Stop-Seat
5	3290-250	2	Pin-Hair	16	106-8717	1	Decal-Service
6	92-7054	3	Spring-Compression	19	121-0732-03	1	Support-Pod
7	104-8300	3	Nut-Flange, NI	20	32144-70	4	Screw-HWHTF
8	5-4460	2	Washer-Pivot	21	3234-29	3	Screw-HHF
9	322-2	2	Screw-HH	22	3256-23	1	Washer-Flat
12	37-8771	2	Bolt-Shoulder	23	3290-307	1	Pin-Hair

Motion Control Assembly

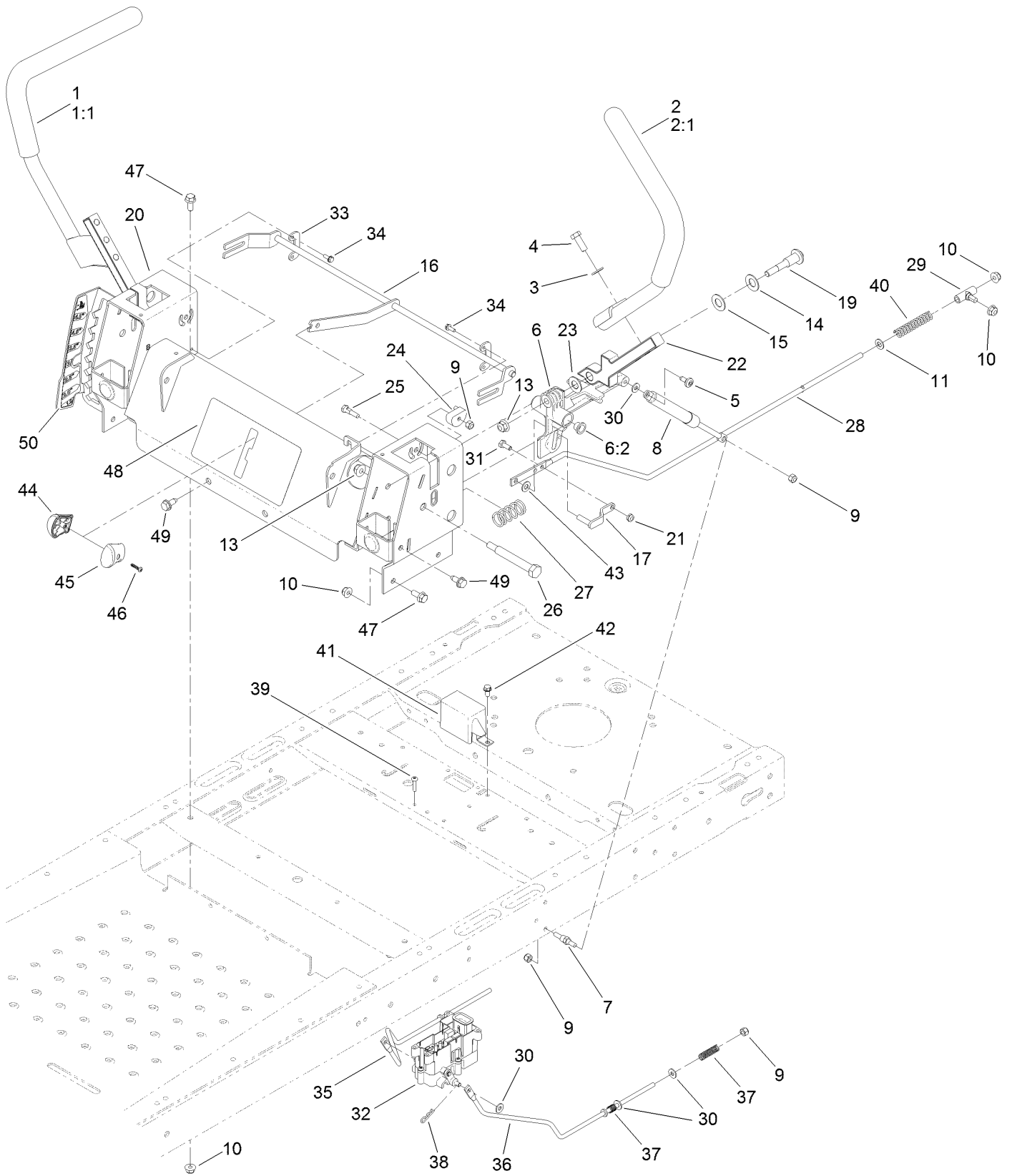

Motion Control Assembly (continued)

<i>Ref.</i>	<i>Part Number</i>	<i>Qty.</i>	<i>Description</i>	<i>Ref.</i>	<i>Part Number</i>	<i>Qty.</i>	<i>Description</i>
1	121-0731	1	Handle-Control, RH	26	115-5099	2	Bolt-Pivot
1:1	121-0726	1	Grip	27	119-8876	2	Spring-Return
2	121-0730	1	Handle-Control, LH	28	117-5388	2	Rod-Hydro
2:1	121-0726	1	Grip	29	119-8842	2	Mount-Rod, Hydro
3	3256-24	4	Washer-Flat	30	119-8952	8	Washer
4	323-6	4	Screw-HH	31	321-3	2	Screw-HH
5	120-7950	2	Screw-Shoulder	32	121-3017	1	Brake Control Module ASM
6	119-3470	2	Actuator Arm ASM	33	117-5385	2	Retainer
6:2	256-156	2	Bushing-Flange	34	32144-1	4	Screw-Taptite
7	110-6810	2	Stud-Damper	35	121-2974	1	Rod-Brake, RH
8	103-2913	2	Damper-Control, Motion	36	121-2975	1	Rod-Brake, LH
9	3296-42	8	Nut-Lock, NI	37	117-1169	4	Spring-Compression
10	104-8300	10	Nut-Flange, NI	38	3290-307	2	Pin-Hair
11	3256-23	2	Washer-Flat	39	32144-36	4	Screw-PPH
13	104-8301	4	Nut-Flange, NI	40	1-603807	2	Spring-Return, Neutral
14	119-8925	2	Washer-Belleville	41	119-8859	1	Cover-Brake
15	117-1240	2	Washer	42	32144-4	1	Screw-HWH
16	119-8832	1	Control-Speed	43	93-6079	2	Spacer-Nylon
17	119-3303	2	Pin-Rod, Hydro	44	119-8935	1	RH Knob ASM
19	117-1198	2	Bolt-Pivot	45	119-8936	1	LH Knob ASM
20	119-3386-03	1	Box-Control	46	94-4496	1	Screw-PPH
21	3296-56	2	Nut-Lock, NI	47	3234-47	6	Screw-HHF
22	115-5098-05	2	Lever-Control	48	120-5468	1	Decal-Speed Control
23	120-2273	2	Washer-Nylon	49	32144-70	4	Screw-HWHTF
24	115-9604	2	Eccentric	50	120-5469	1	Decal-HOC
25	119-3301	2	Bolt-Pivot, Eccentric				

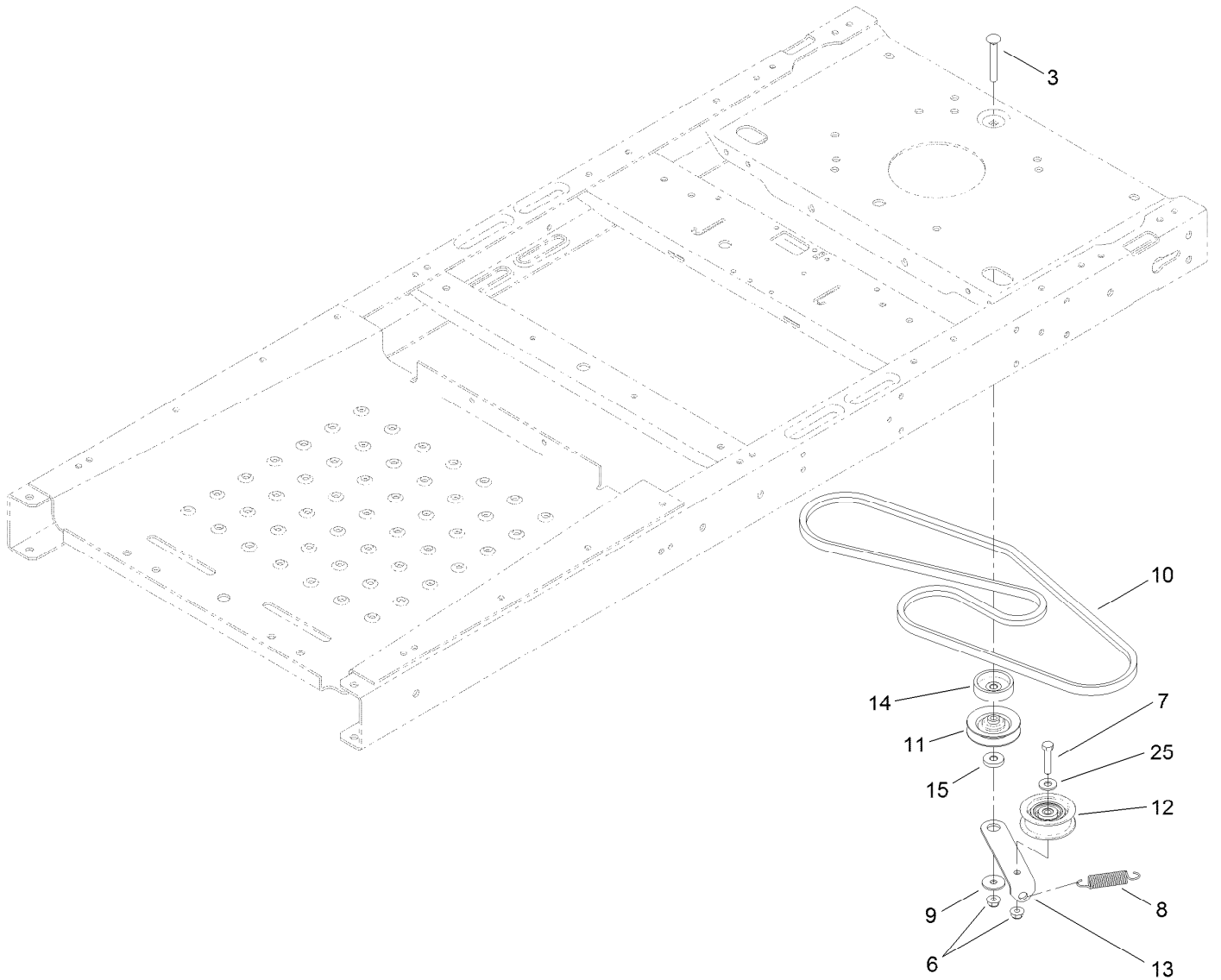

Belt and Idler Assembly

Ref.	Part Number	Qty.	Description
3	3230-8	1	Screw-CARR
6	104-8300	2	Nut-Flange, NI
7	322-7	1	Screw-HH
8	104-6415	1	Spring-Return, Pedal
9	5-4460	1	Washer-Pivot
10	119-3309	1	V-Belt
11	119-8822	1	Pulley-Idler
12	106-2176	1	Pulley-Idler
13	119-3326	1	Arm-Idler
14	119-3353	1	Spacer
15	119-3327	1	Spacer-Arm, Idler
25	3256-3	1	Washer-Flat

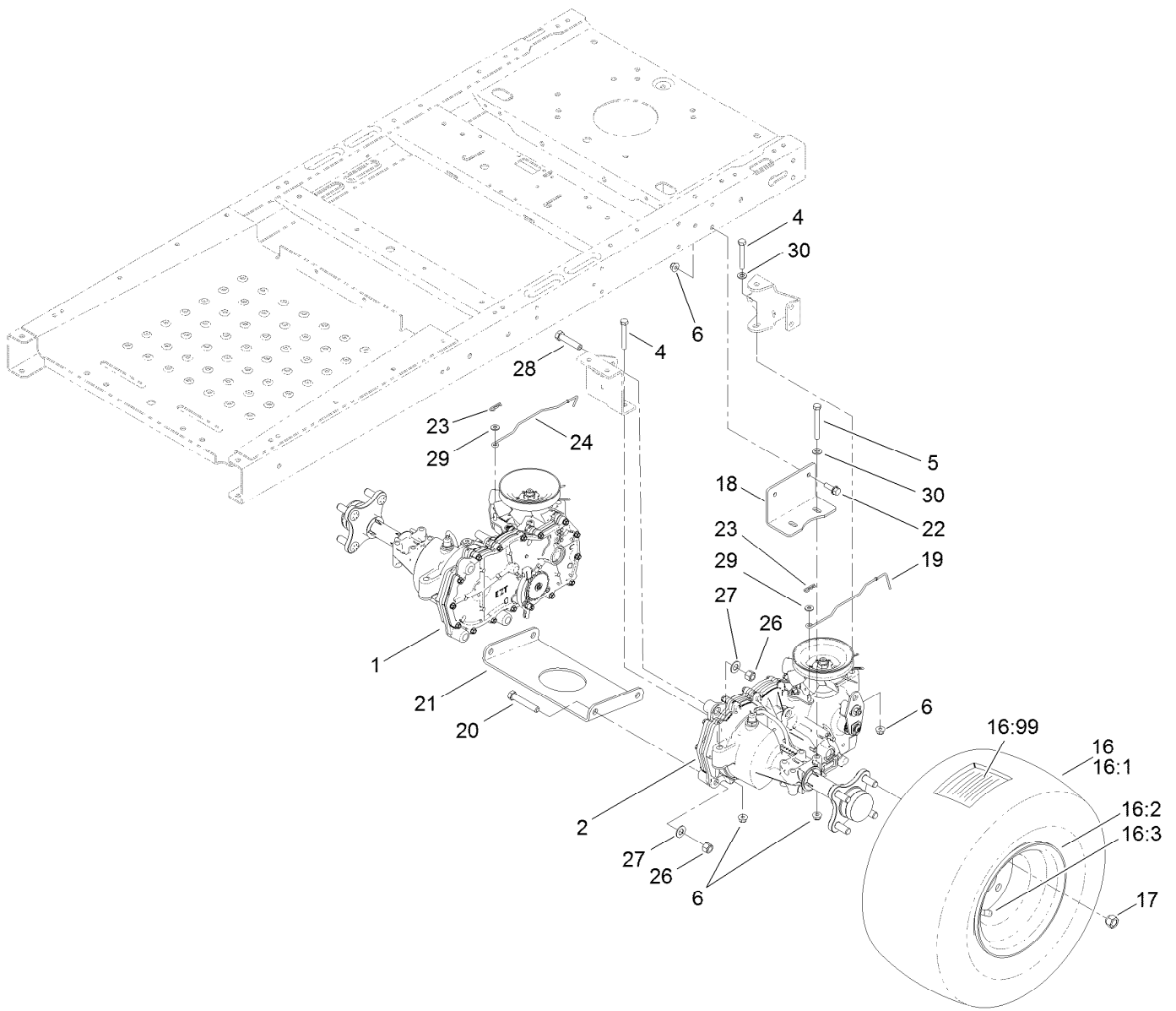

Hydro Transaxle Assembly

Ref.	Part Number	Qty.	Description	Ref.	Part Number	Qty.	Description
1	119-3341	1	RH Hydro Transaxle ASM	19	121-2971	1	Rod-Bypass, LH
2	119-3340	1	LH Hydro Transaxle ASM	20	324-10	4	Screw-HH
4	322-11	4	Screw-HH	21	119-3339-03	1	Plate-Cross, Hydro
5	322-13	4	Screw-HH	22	3234-29	4	Screw-HHF
6	104-8300	12	Nut-Flange, NI	23	3290-307	2	Pin-Hair
16	120-5523	2	Wheel And Tire ASM	24	121-0752	1	Rod-Bypass, RH
16:1	119-8907	1	Tire	26	3296-48	6	Nut-Lock, NI
16:2	107-2475	1	Wheel	27	3256-25	6	Washer-Flat
16:3	232-27	1	Stem-Valve	28	324-8	2	Screw-HH
16:99	107-2491	1	Tube-Tire	29	3256-22	2	Washer-Flat
17	242-50	8	Nut-Lug	30	3256-23	6	Washer-Flat
18	117-7264-03	2	Mount-Hydro				

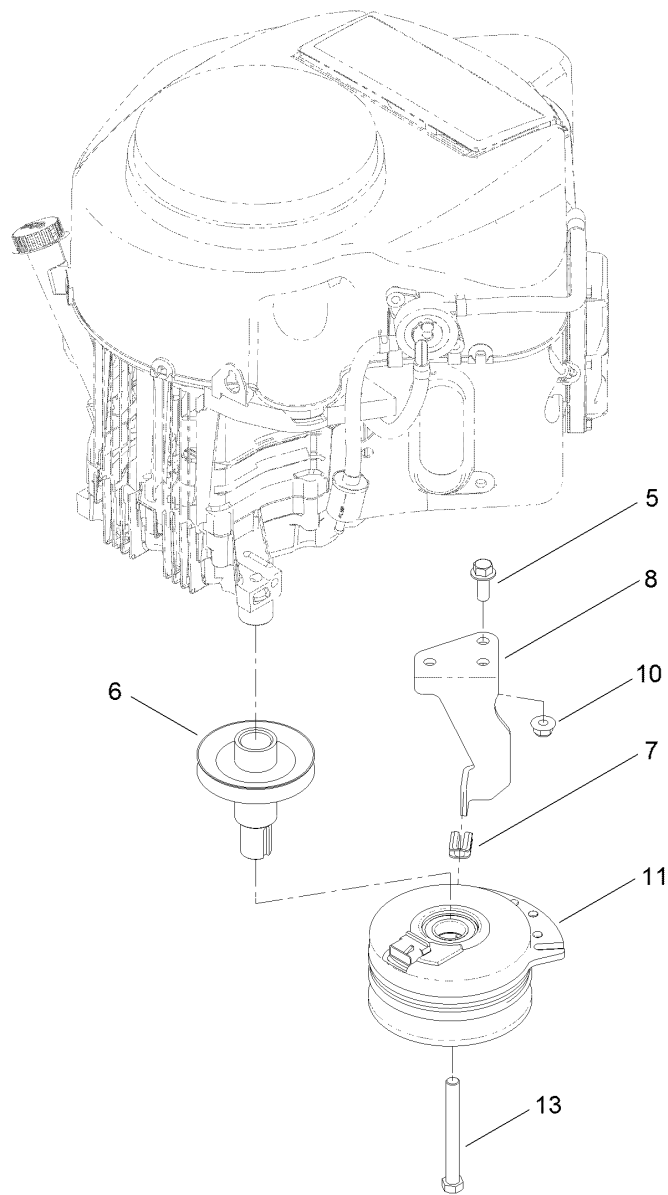

Clutch Assembly

<i>Ref.</i>	<i>Part Number</i>	<i>Qty.</i>	<i>Description</i>
5	3234-42	1	Screw-HHF
6	119-3318	1	Pulley-Engine
7	120-2217	1	Isolator-Clutch
8	119-8884	1	Stop-Clutch
10	104-8301	1	Nut-Flange, NI
11	117-7468	1	Clutch-Electric
13	3212-16	1	Screw-HH

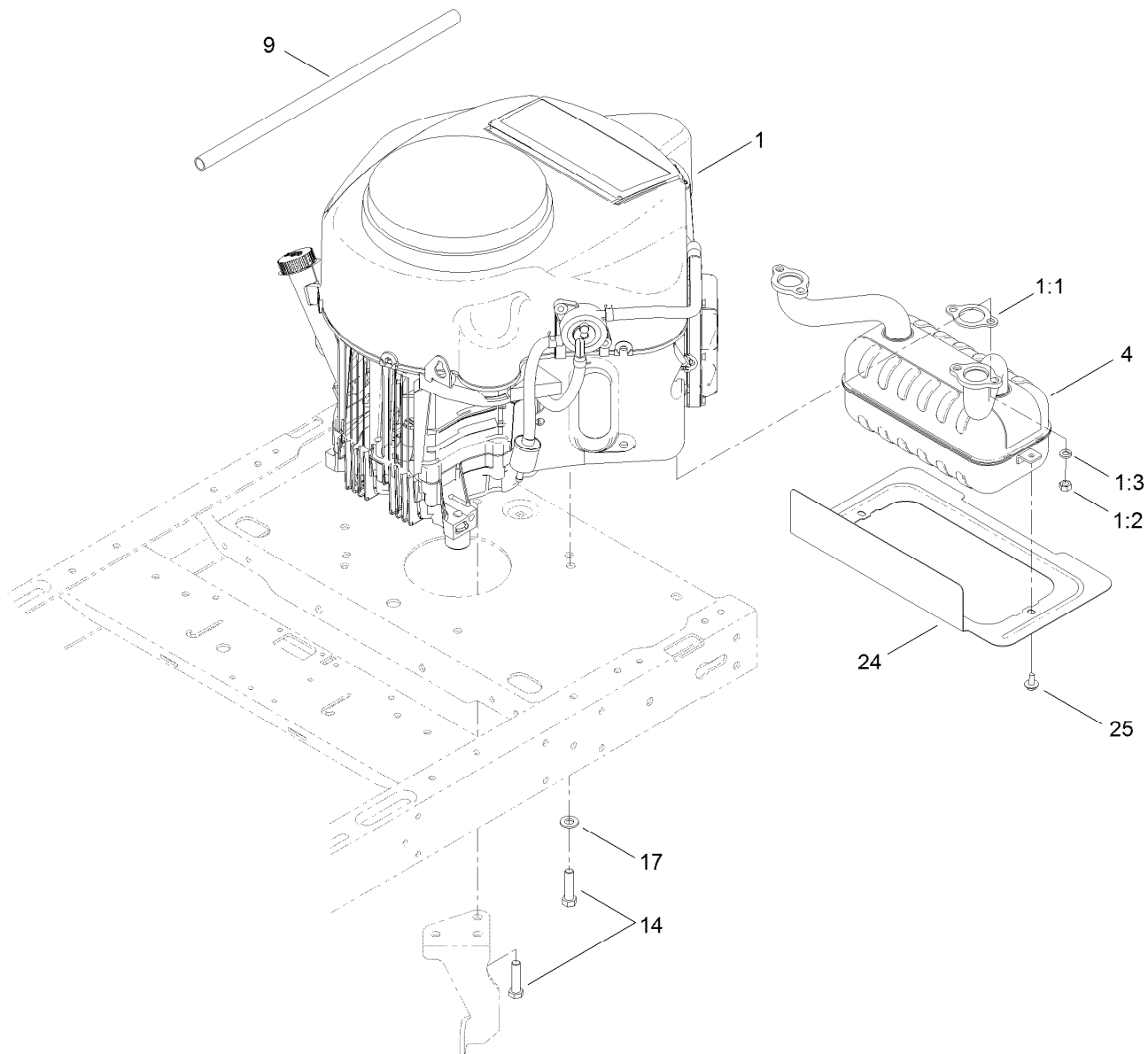

Engine and Muffler Assembly

Ref.	Part Number	Qty.	Description
1		1	Engine-Kawasaki, Fr691V-_s07-R ●■
1:1	1-653313	2	Gasket-Exhaust
1:2	114-3549	4	Nut
1:3	114-3550	4	Washer-Lock, Spring
4	117-7256	1	Muffler-Kawasaki
9	106-7022	1	Tube-Drain, Oil
14	323-50	4	Bolt-HH
17	3256-24	3	Washer-Flat
24	121-2973-03	1	Shield-Heat
25	46-8560	2	Screw-HHFTF

● Not serviced separately

■ Obtain parts from www.kawpowerpc.com

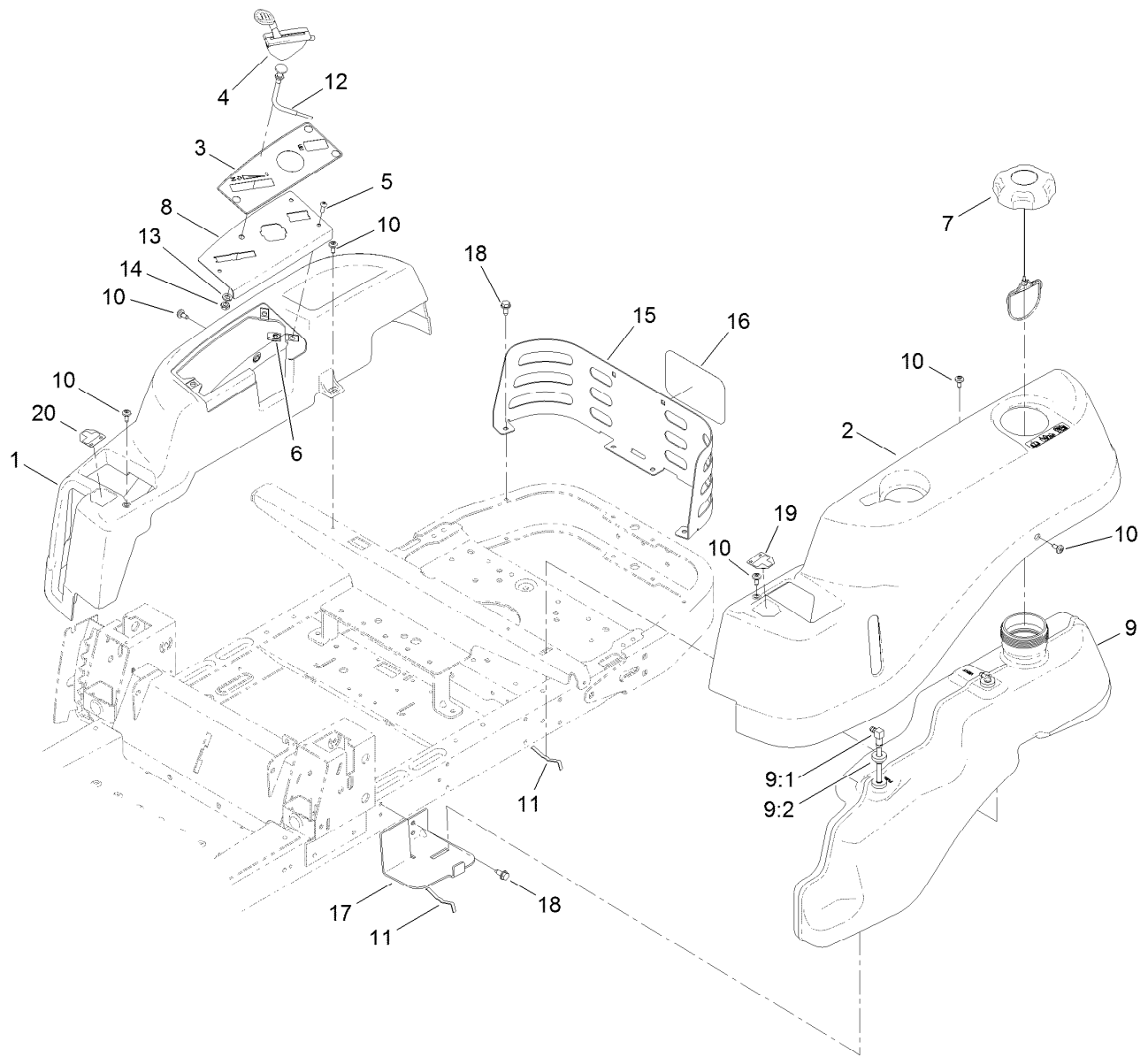

Body Styling and Fuel Pod Assembly

<i>Ref.</i>	<i>Part Number</i>	<i>Qty.</i>	<i>Description</i>	<i>Ref.</i>	<i>Part Number</i>	<i>Qty.</i>	<i>Description</i>
1	119-3335	1	Pod-RH	10	120-7950	6	Screw-Shoulder
2	119-3334	1	Pod-LH	11	609830	2	Spring
3	121-0772	1	Decal-Panel, Control	12	112-9753	1	Cable-Choke
4	121-0769	1	Cable-Throttle	13	3253-21	1	Washer-Lock
5	3258-166	3	Screw-PRH	14	3220-3	1	Nut-HJ
6	107069	3	Clip	15	119-8855-03	1	Guard-Rear
7	120-5461	1	Cap-Fuel, Ratcheting	16	105-8278	1	Decal
8	119-3378-03	1	Plate-Control	17	119-3476-03	1	Support-Tank, Front
9	119-3324	1	Fuel Tank ASM	18	32144-70	6	Screw-HWHTF
9:1	121-0793	1	Connector-Elbow, 90 DEG	19	119-8814	1	Decal-Control Lever, LH
9:2	46-6560	2	Bushing	20	119-8815	1	Decal-Control Lever, RH

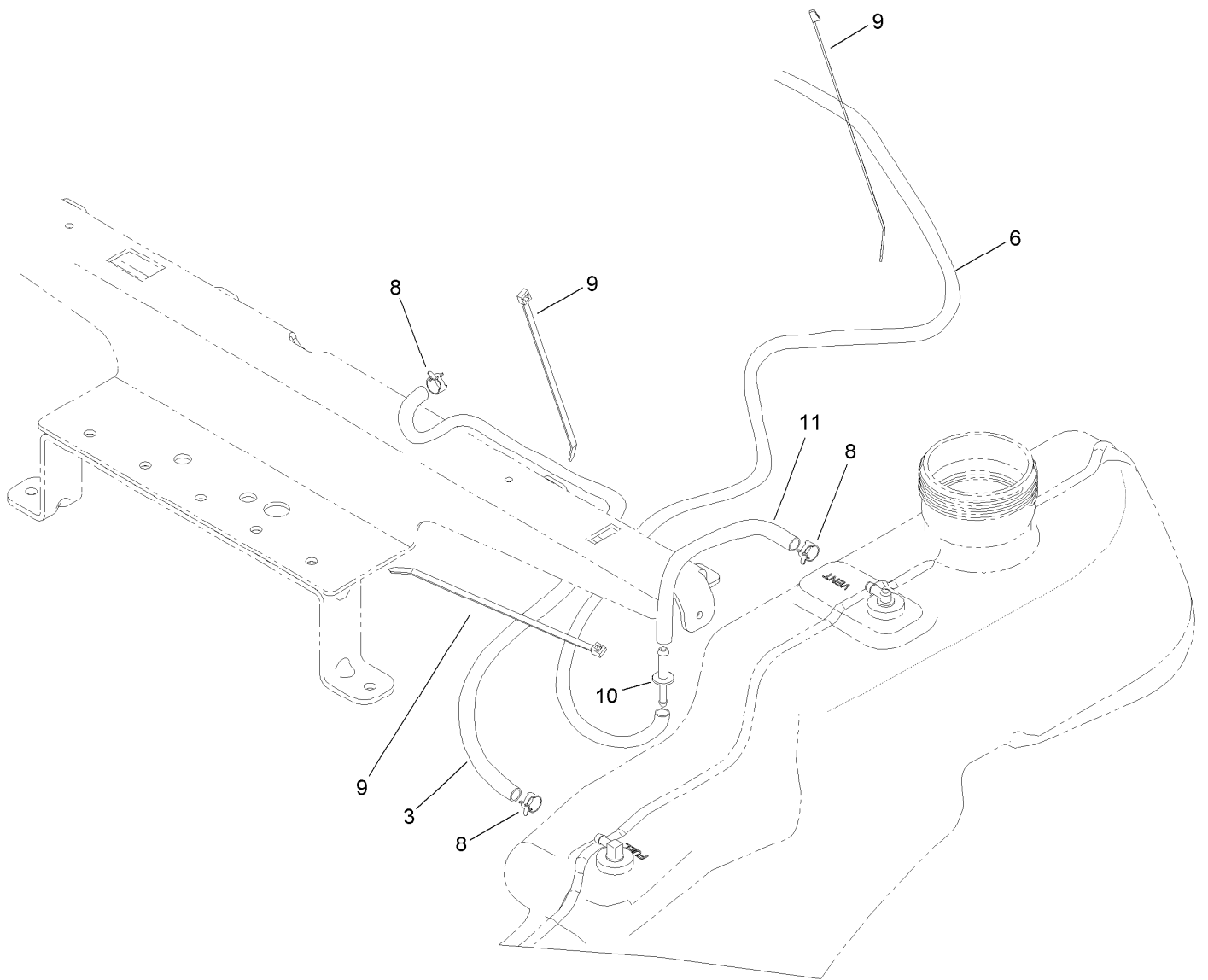

Fuel Delivery Assembly

<i>Ref.</i>	<i>Part Number</i>	<i>Qty.</i>	<i>Description</i>
3	109-0301	1	Hose-Fuel
6	51-3212	1	Hose-Fuel
8	2412-98	3	Clamp-Hose
9	614249	3	Tie-Cable
10	117-5399	1	Adaptor-Orifice
11	110-1876	1	Hose-Fuel

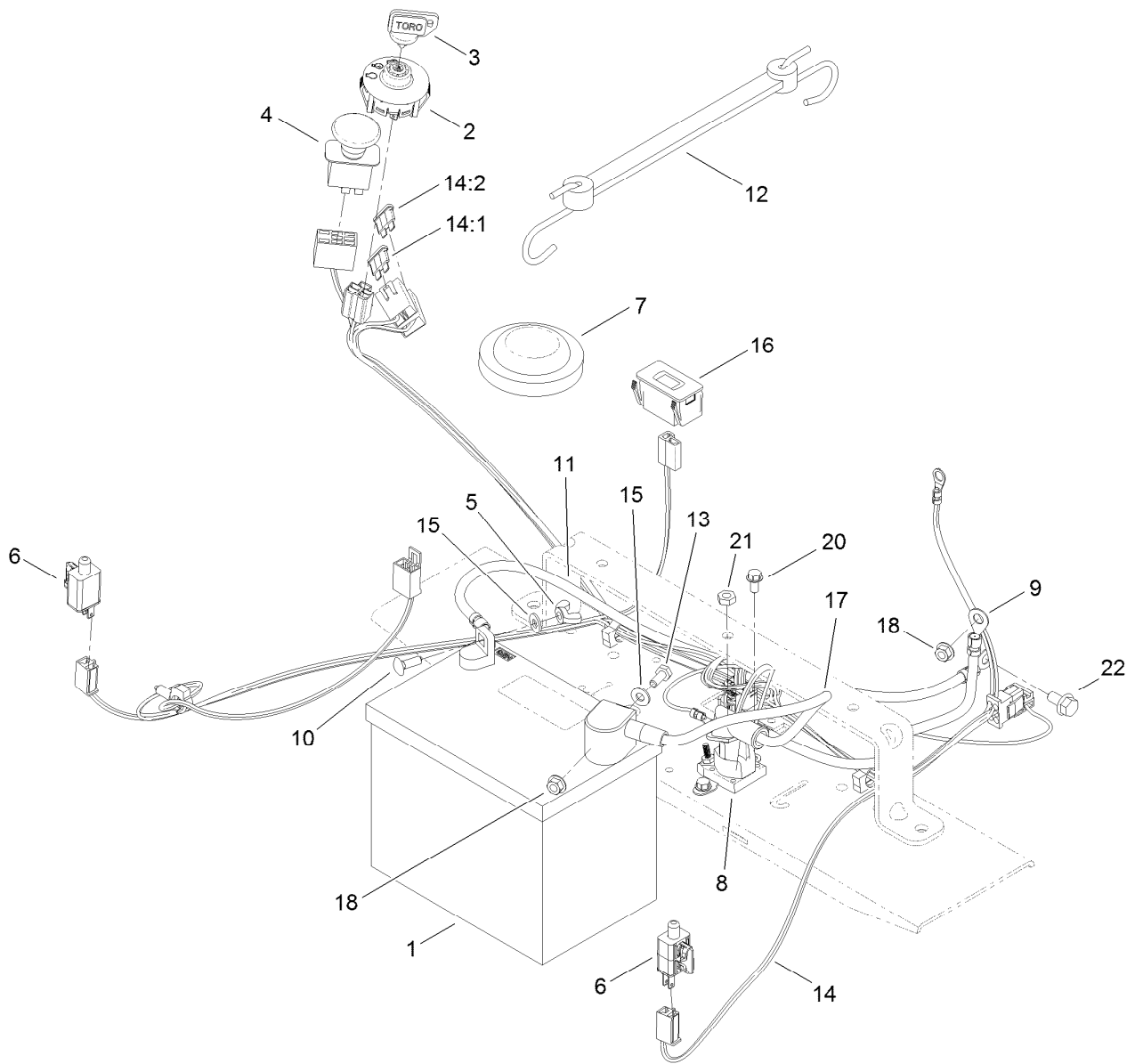

Battery and Electrical Assembly

Ref.	Part Number	Qty.	Description
1	105-1692	1	Battery
2	117-2221	1	Switch-Ignition
3	63-8360	1	Key-Ignition (W/Shield)
4	103-5221	1	Switch-PTO
5	32103-22	1	Nut-Wing
6	110-6765	2	Switch-Single Pole No
7	100-3524	1	Switch-Seat
8	117-1197	1	Solenoid
9	119-8898	1	Cable-Battery, Red
10	3229-1	1	Bolt-CARR
11	119-8899	1	Cable-Battery, Black
12	104-2466	1	Holddown-Battery

Ref.	Part Number	Qty.	Description
13	321-3	1	Screw-HH
14	121-5652	1	Harness-Wire
14:1	109103	1	Fuse-Blade, 30 Amp
14:2	109102	1	Fuse-Blade, 25 Amp
15	3256-22	2	Washer-Flat
16	120-2244	1	Hourmeter
17	119-8897	1	Cable-Battery, Red
18	32128-33	2	Nut-HF
20	32144-4	2	Screw-HWH
21	3220-2	2	Nut-Jam
22	33104-016	1	Screw-HHF

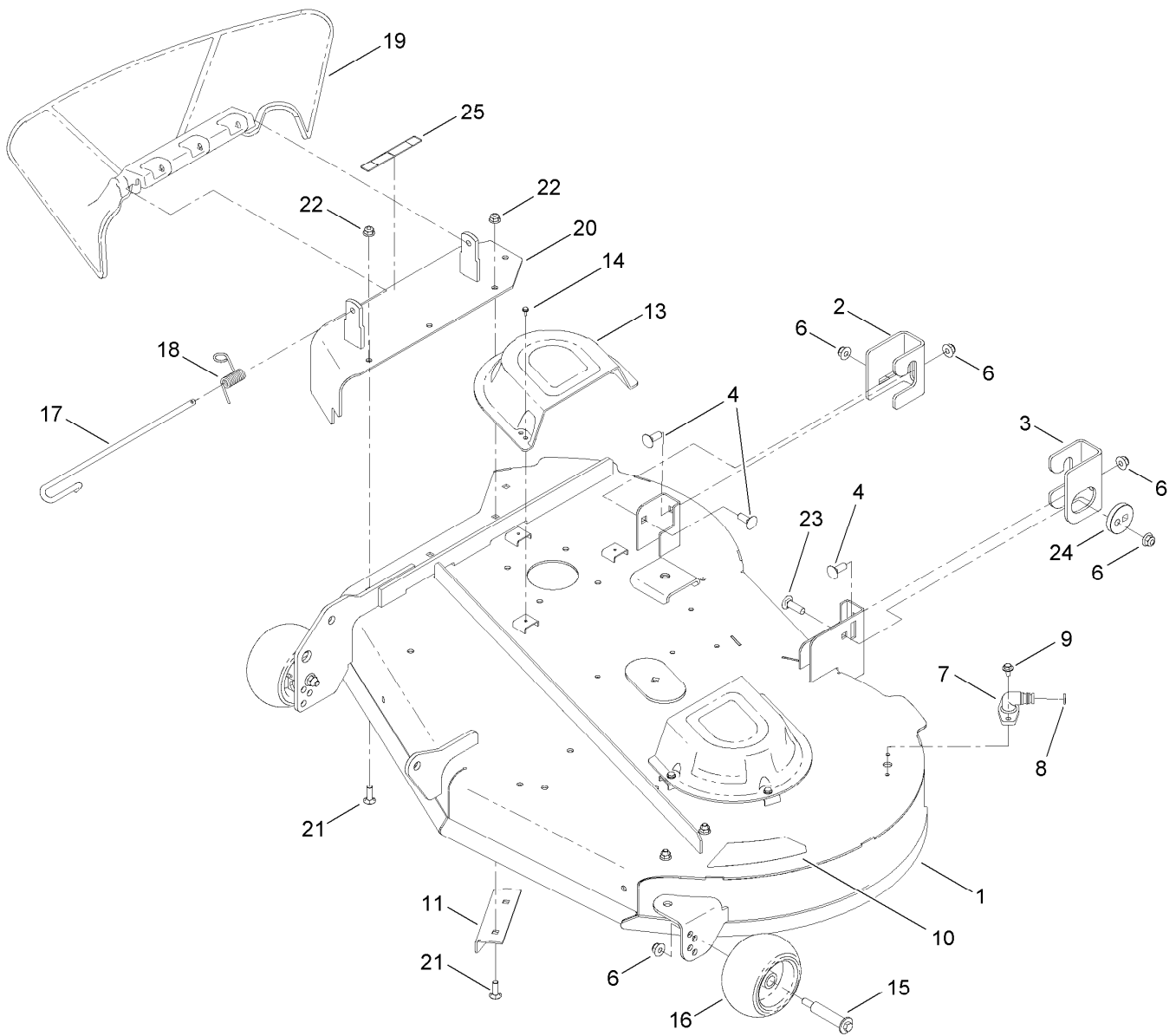

42 Inch Deck Assembly

Ref.	Part Number	Qty.	Description	Ref.	Part Number	Qty.	Description
1	121-0733	1	42 Inch Deck And Decal ASM	14	32144-1	6	Screw-Taptite
2	119-3494	1	Bracket-Hanger, RH	15	112-3977	2	Bolt-Shoulder
3	121-0797	1	Bracket-Hanger, LH	16	1-603299	2	Roller-Scalp, Anti
4	3231-2	3	Bolt-CARR	17	109-8854	1	Pin-Chute
6	104-8301	6	Nut-Flange, NI	18	121-2983	1	Spring-Torsion
7	95-2747	1	Fitting-Washout	19	121-0739	1	Deflector-Discharge
8	46-6290	1	O-Ring, Seal	20	120-7945-01	1	Discharge Cover ASM
9	46-8560	2	Screw-HHFTF	21	3230-22	4	Screw-CARR
10	121-0791	1	Decal-Deck	22	104-8300	4	Nut-Flange, NI
11	120-7951-03	1	Baffle-Cutoff	23	3231-28	1	Screw-CARR
13	108-7889	2	Cover-Belt	24	112-3980	1	Eccentric
				25	93-7009	1	Decal-Danger, Deflector

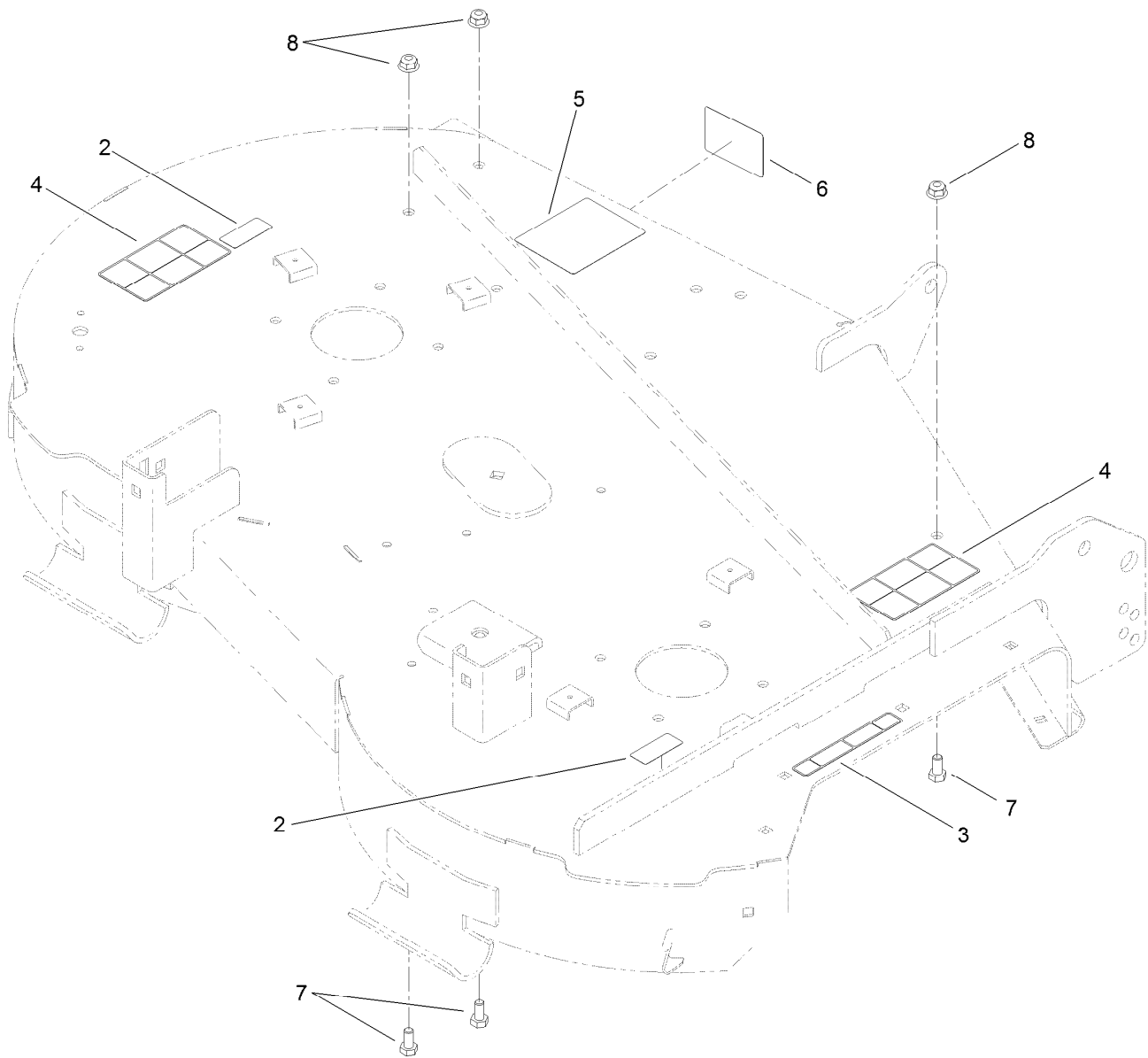

42 Inch Deck and Decal Assembly No. 121-0733

<i>Ref.</i>	<i>Part Number</i>	<i>Qty.</i>	<i>Description</i>
2	114-1606	2	Decal-Danger, Pulley
3	93-7009	1	Decal-Danger, Deflector
4	110-6691	2	Decal-Danger
5	105-7015	1	Decal-Routing, Belt
6	112-9840	1	Decal-Scalp, Anti
7	322-2	3	Screw-HH
8	104-8300	3	Nut-Flange, NI

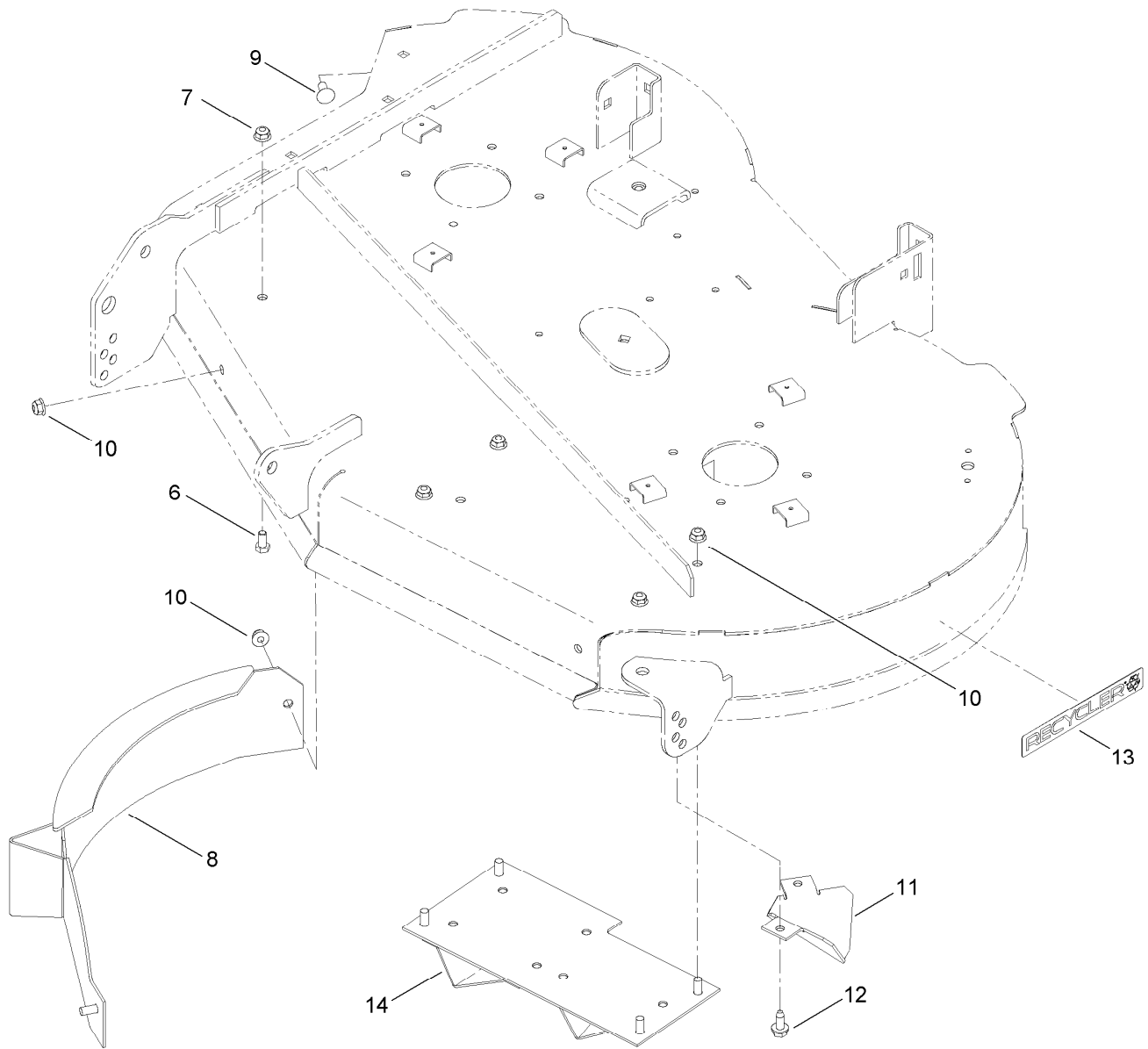

42 Inch Deck Baffle Assembly

Ref.	Part Number	Qty.	Description
6	322-2	1	Screw-HH
7	104-8300	1	Nut-Flange, NI
8	121-5691-03	1	Baffle ASM
9	3230-1	1	Bolt-CARR
10	104-8300	6	Nut-Flange, NI
11	119-3389-03	1	Kicker-Flanged
12	32144-70	2	Screw-HWHTF
13	119-2368	1	Decal-Recycler
14	121-5690-03	1	Kicker ASM

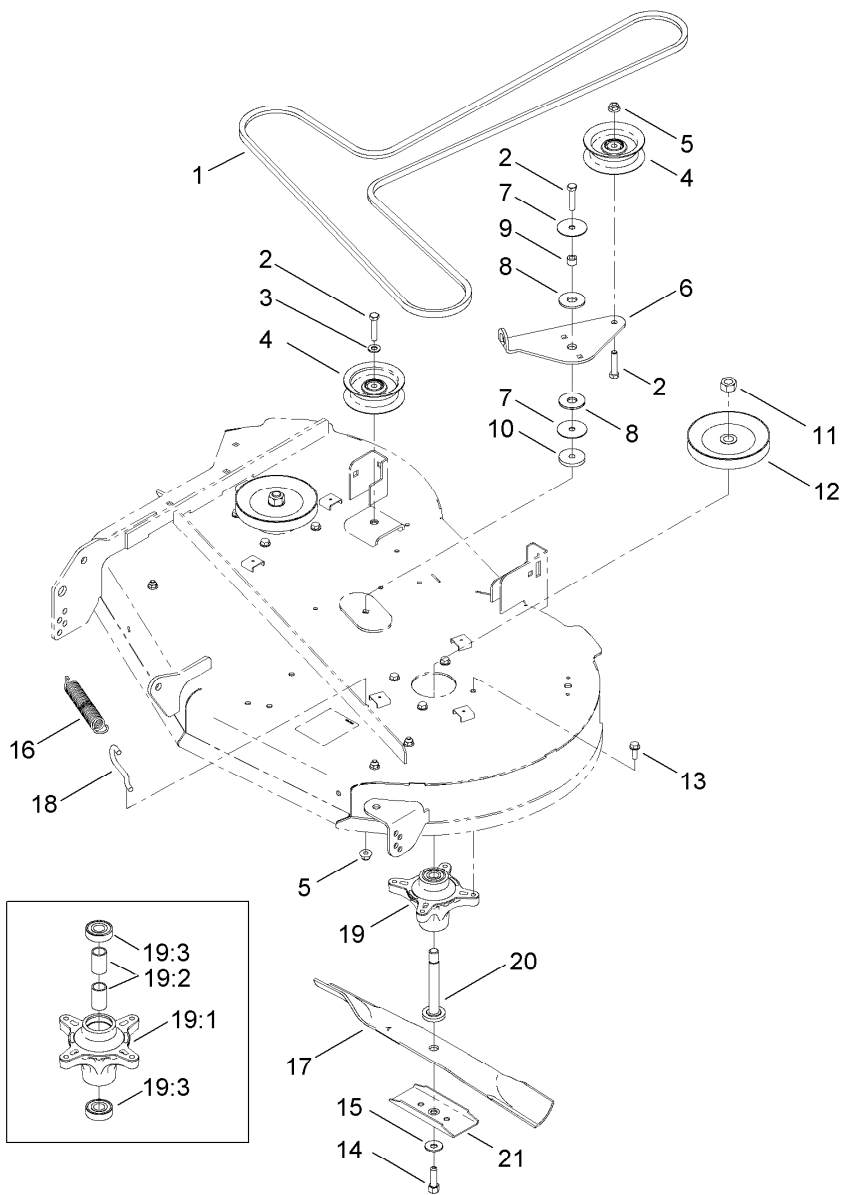

42 Inch Deck Belt and Blade Assembly

Ref.	Part Number	Qty.	Description	Ref.	Part Number	Qty.	Description
1	119-8819	1	V-Belt	13	32144-41	8	Screw-Taptite
2	323-9	3	Screw-HH	14	26-0671	2	Screw-HH
3	3256-24	1	Washer-Flat	15	3290-465	2	Washer-Belleville
4	106-2175	2	Pulley-Idler, Flat	16	106-2177	1	Spring-Extension
5	104-8301	2	Nut-Flange, NI	17	106-2247-03	2	Blade
6	114-8540	1	Arm-Idler	18	88-5970	1	Hook-Return, Spring
7	120-2229	2	Washer-Idler Pivot	19	121-0751	2	Spindle ASM
8	114-0463	2	Washer-Friction, Composite	19:1	117-7267	1	Spindle
9	115-4986	1	Spacer	19:2	120-7935	2	Spacer
10	110-9981	1	Washer-Plain	19:3	100-1048	2	Bearing-Ball
11	3219-6	2	Nut-Hex	20	117-7268	2	Shaft-Spindle
12	110-6864	2	Pulley	21	106-2248-03	2	Stiffener-Blade

Attachments and Accessories

For 74390 TimeCutter ZS 4200TF Riding Mower

Product Name	Model/Part
Bagging Enhancement Kit	121-5698
Striping Kit	121-5702
Sunshade Kit, 2011 and After Zero-Turn-Radius Riding Mower	79011
Hitch Kit	79014
42in Replacement Blade Kit.....	79220
Storage Cover	79317
42in Bagger	79336
10 cu. ft. Poly Dump Cart	79991

Notes:

Notes:



Count on it.