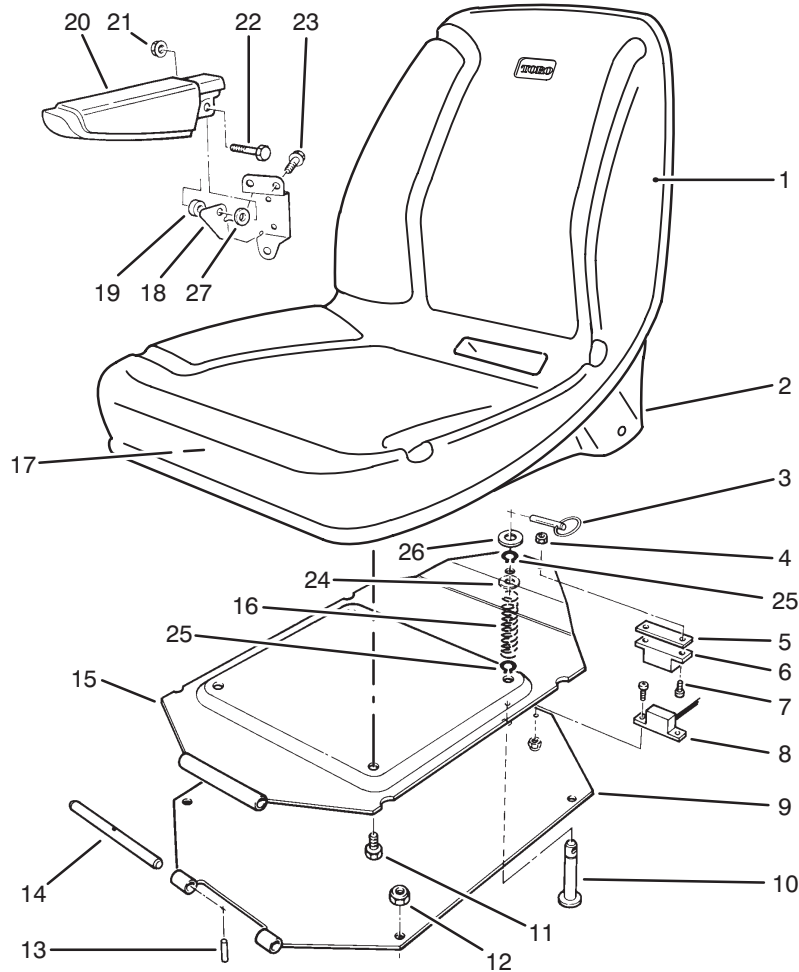

TORO[®]

MODEL NO. 30580-50146

**PARTS
CATALOG****GROUNDMASTER[®] 580-D
Traction Unit**

T-1278C

SEAT ASSEMBLY

Ref. No.	Part No.	Description	No. Used
1	92-1180	Assembly - Seat (Incl. Ref. #2)	1
2	67-9560	Shell - Seat	1
3	283-72	Pin - Lynch	1
4	3296-54	Nut - Lock	4
5	83-6630	Shim - Switch	1
6	92-8753	Catch - Magnetic	1
7	32122-53	Screw - Pan Head	4
8	83-6640	Sensor - Switch	1
9	83-6700	Plate - Suspension	1
10	85-6160	Pin - Spring	1
11	3234-5	Screw - Cap Hex. Hd.	4
12	3296-29	Nut - Lock	4
13	32121-4	Pin - Roll	1
14	27-4720	Pin - Pivot Seat	1

Ref. No.	Part No.	Description	No. Used
15	83-6690	Plate - Seat	1
16	85-6140	Spring	1
17	92-1179	Cushion - Seat	1
18	69-0770	Bracket - Arm Rest R.H.	1
*	69-0760	Bracket - Arm Rest L.H.	1
19	92-7301	Spacer	2
20	69-1180	Armrest	2
21	32128-19	Nut - Lock Flange Hd.	2
22	323-9	Screw - Cap Hex. Hd.	2
23	3234-14	Screw - Cap Hex. Hd.	6
24	3256-27	Washer - Flat	1
25	32120-64	Ring - Retaining	2
26	3256-7	Washer - Flat	1
27	3256-24	Washer - Flat	2

*Not Illustrated

© The TORO Company - 1995
All Rights Reserved

TPS

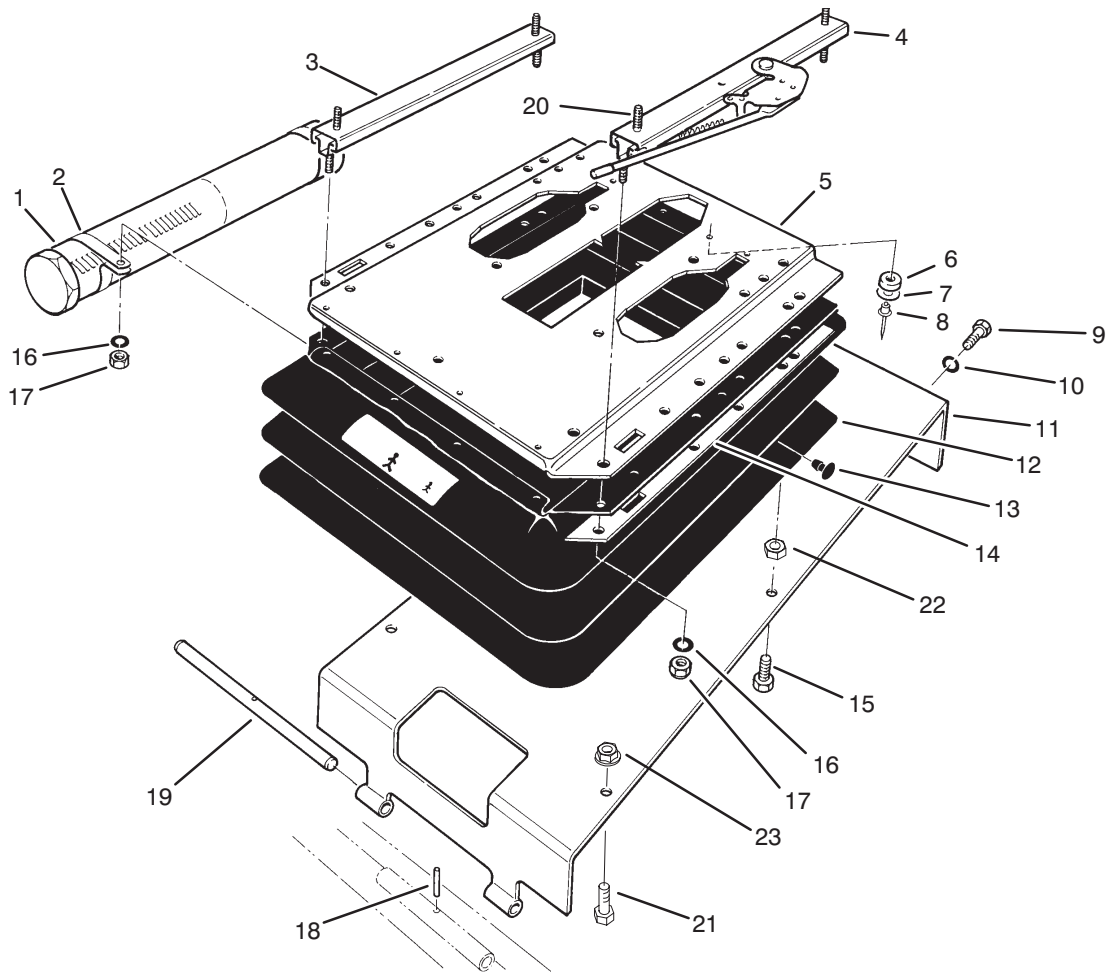

T-1279B

SEAT PIVOT AND BELLOWS ASSEMBLY

Ref. No.	Part No.	Description	No. Used
1	74-0720	Tube - Manual	1
2	2412-133	Clamp	2
3	66-8530	Track - Adjustment	1
4	82-9060	Track & Latch - Adjustment	1
5	71-2410	Plate - Upper Suspension (Incl. Ref. #6)	1
6	71-2400	Assembly - Bumper (Incl. Ref. #7 & 8)	2
7	71-2380	Washer	2
8	71-2390	Rivet - Pop	2
9	323-6	Screw - Cap Hex. Hd.	2
10	3253-21	Washer - Lock	2
11	83-6660	Support - Seat	1

Ref. No.	Part No.	Description	No. Used
12	71-2420	Bellows - Rubber	1
13	39-5710	Plug	21
14	40-3890	Trim	2
15	48-7780	Screw - Cap Hex. Hd.	2
16	3256-23	Washer - Flat	4
17	3296-29	Nut - Lock	4
18	32121-4	Pin - Roll	1
19	27-4720	Pin - Pivot, Seat	1
20	3230-22	Bolt - Carriage	1
21	33104-025	Screw - HHF	2
22	33015-00	Nut	2
23	33004-00	Nut - HWH	2

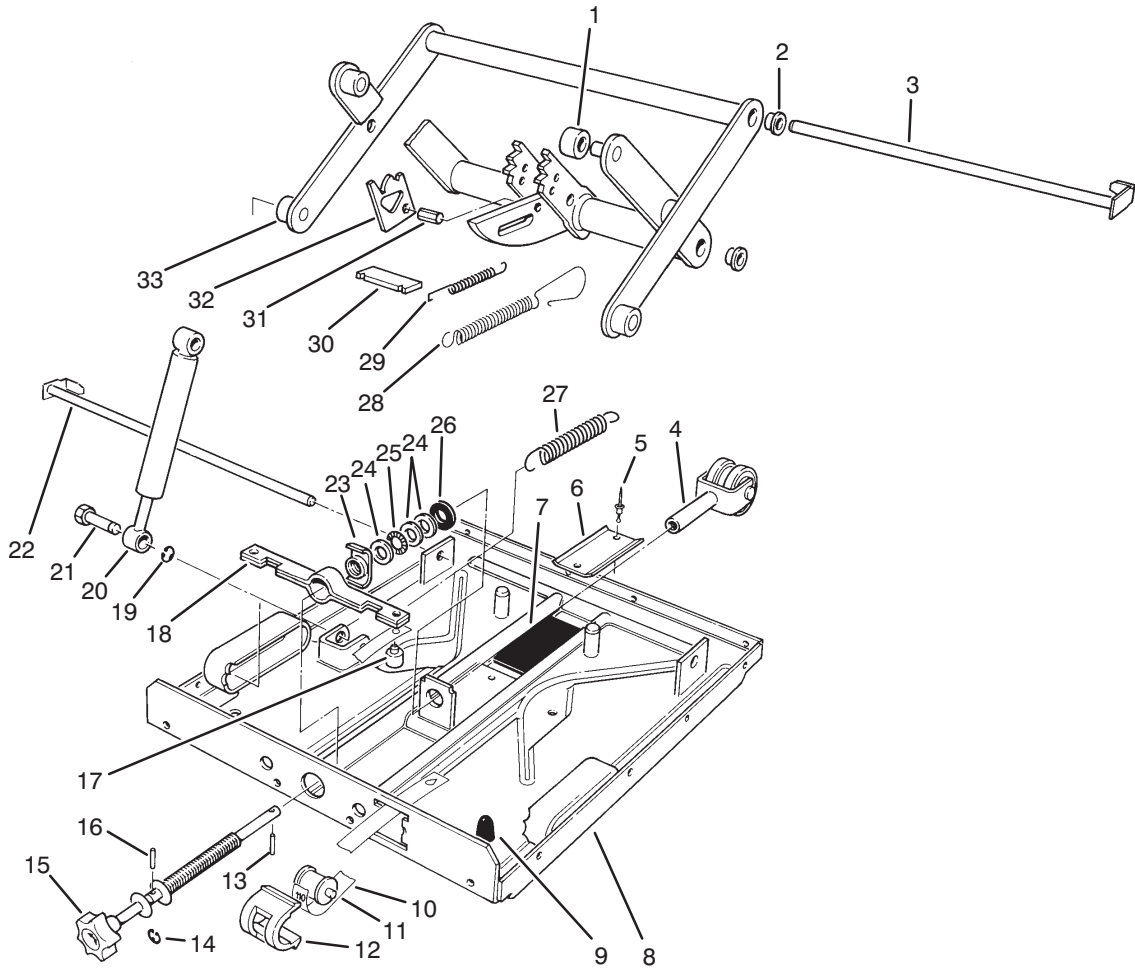

T-0483

SEAT SUSPENSION ASSEMBLY

Ref. No.	Part No.	Description	No. Used	Ref. No.	Part No.	Description	No. Used
1	40-4010	Roller	4	19	71-2330	Ring - Snap	2
2	71-2180	Bearing	4	20	71-2340	Absorber - Shock	1
3	71-2190	Pin	1	21	71-2320	Pin	2
4	71-2290	Bearing - Triple	1	22	71-2170	Pin	1
5	40-4090	Rivet - Pop	2	23	71-2270	Nut - Special	1
6	40-4080	Track - U	1	24	40-4070	Washer	3
7	40-4120	Plate - Rubber	1	25	40-4310	Bearing - Thrust Needle	1
8	71-2310	Plate - Lower Suspension (Incl. Ref. #5-7 & 9)	1	26	40-4060	Washer - Rubber	1
9	71-2300	Bumper	2	27	71-2260	Spring	2
10	71-2280	Band - Weight Indicator	1	28	40-4340	Spring - Extension	1
11	40-4150	Roller	1	29	40-4350	Spring - Extension	2
12	40-4160	Guide - Sleeve	1	30	40-4360	Plate	1
13	71-2210	Pin	1	31	40-4370	Bolt	1
14	71-2230	Ring - Snap	1	32	40-4380	Bracket - Release	2
15	71-2240	Knob Assembly (Incl. Ref. #13, 14 & 16)	1	33	71-2200	Bracket - Swing Arm (Incl. Ref. #1-3, 22 & 29-32)	1
16	71-2220	Pin	1	*	71-0480	Suspension Assembly (Incl. Ref. #1-33, & 6-8, 12 & 13, from page 2)	1
17	40-4230	Plug	1				
18	71-2250	Bracket - Spring	1				

*Not Illustrated

STEERING TOWER ASSEMBLY

Ref. No.	Part No.	Description	No. Used
1	69-1560	Lever - Lock	1
2	69-9230	Shaft - Steering Pivot	1
3	233-17	Knob	1
4	69-9440	Panel - Steering Tower	1
5	44-2210	Body - Indicator Light	1
†6		(Incl. Ref. #6-7 & 23-24)	1
		Bulb - Indicator Light (#1891)	3
7	218-533	Lens - Indicator Light (Red)	1
8	213-31	Cover - Steering Wheel	1
9	47-6990	Nut - Hex.	1
10	68-8080	Wheel - Steering	1
11	218-562	Lens - Indicator Light (Amber)	2
12	44-2212	Body - Indicator Light (Incl. Ref. #6, 11 & 23-24)	2
13	32144-64	Screw - Hex. Washer Hd.	4
14	20-9500	Spacer	2
15	31-0390	Washer - Friction	3
16	323-7	Screw - Cap Hex. Hd.	4
17	3253-21	Washer - Lock	4
18	69-9540	Bracket - Steering Gear	1
19	69-7760	Link - Steering Gear	1
20	3296-49	Nut - Lock	1
21	69-7740	Support - Steering Gear	1
22	32128-20	Nut - Flange Lock	2
23	218-536	Washer - Lock	3

Ref. No.	Part No.	Description	No. Used
24	218-535	Nut - Hex.	3
25	3234-14	Screw - Hex. Washer Hd.	8
26	46-1600	Spacer	4
27	71-0540	Column - Steering	1
28	92-9748	Valve - Power Steering	1
29	3256-26	Washer - Flat	3
30	325-5	Screw - Cap Hex. Hd.	3
31	69-8160	Tower - Steering	1
32	340-133	Fitting - Hydraulic Straight (Incl. Ref. #37 & 39)	3
33	69-5500	Hose - Hydraulic	4
34	32128-23	Nut - Flange Lock	3
35	28-0380	Spacer	3
36	3290-378	Tie-Cable	5
37	237-22	Seal - O-Ring	4
38	69-6980	Valve - Check (Incl. Ref. # 37 & 39)	1
39	237-79	Seal - O-Ring	4
40	71-4060	Rod - Brake Latch	1
41	69-8510	Cover - Steering Tower	1
42	32144-96	Screw - Mach. Round Hd.	3
43	3272-5	Pin - Cotter	1
44	3256-22	Washer - Flat	1
45	3-3251	Spring - Compression	1
46	69-0970	Panel - Control	1
47	62-5550	Decal	1

†Obtain Locally

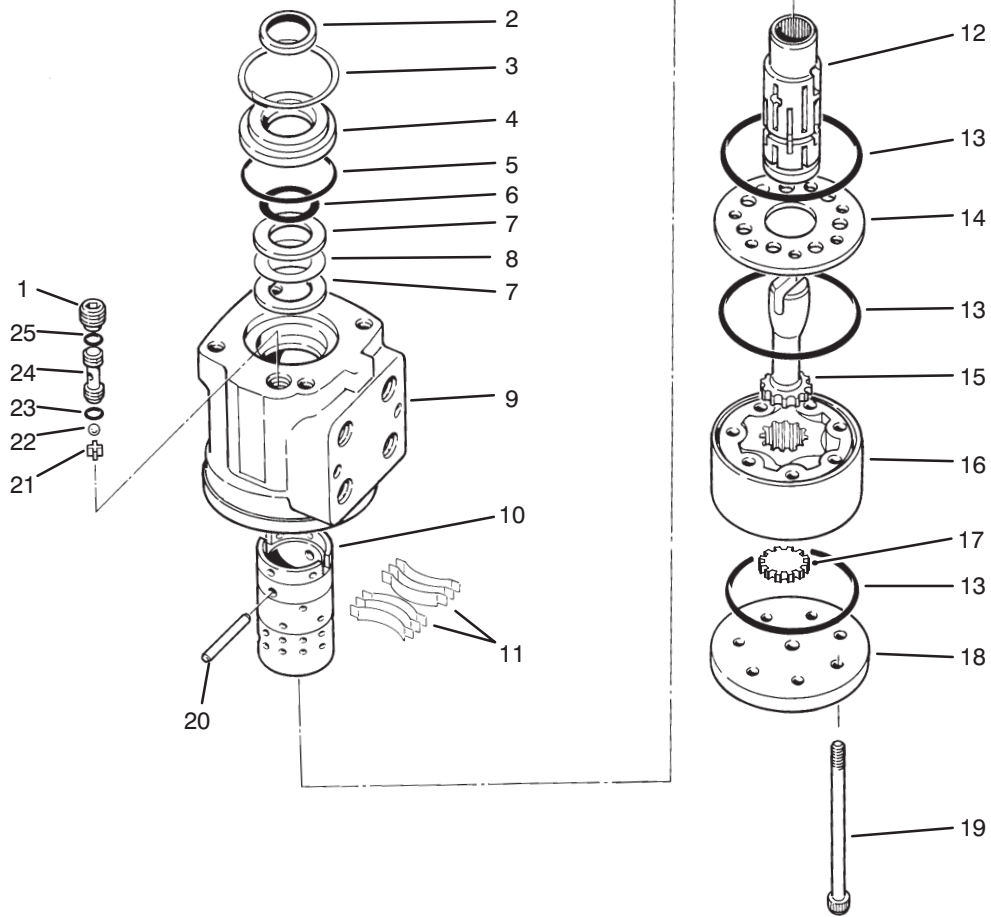

T-0383A

POWER STEERING VALVE ASSEMBLY NO. 92-9748

Ref. No.	Part No.	Description	No. Used
1	52-9260	Screw - Set	1
†2		Seal - 1" ID	1
3	52-9230	Ring - Retaining	1
4	52-9240	Bushing - Gland Seal	1
†5		Seal - 1.875" ID	1
†6		Seal - Quad Ring	1
7	59-6730	Race - Bearing	2
8	59-6740	Bearing - Needle Thrust	1
†9		Housing	1
†10		Sleeve - Control	1
†11	59-6820	Centering Spring Kit	1
†12		Spool - Control	1
†13		Seal	3
14	92-9732	Plate - Wear	1
15	52-9320	Drive	1

Ref. No.	Part No.	Description	No. Used
16	69-1860	Gerotor	1
17	69-1880	Spacer	1
18	92-9730	Cap - End	1
19	92-9735	Screw - Cap	7
20	59-6830	Kit - Centering Pin	1
21	52-9290	Retainer - Check Ball	1
22	52-9280	Ball - Check	1
†23		Seal	1
24	52-9270	Seat - Check Ball	1
†25		Seal	1
*	52-9250	Needle Bearing Kit (Incl. Ref. #7-8)	1
*	92-9749	Seal Kit (Incl. Ref. #2, 5-6, 13, 23 & 25)	1

*Not Illustrated

†Not Serviceable Separately

STEERING BRAKE ASSEMBLY

Ref. No.	Part No.	Description	No. Used
1	256-247	Bushing - Flange	4
2	69-7890	Arm - Brake R.H. (Incl. Ref. #1 & 3)	1
3	302-5	Fitting - Grease	2
4	69-9210	Lever - Brake Latch	1
5	321-4	Screw - Cap Hex. Hd.	1
6	3272-5	Pin - Cotter	1
7	69-7720	Pawl - Brake	1
8	69-9200	Pin - Brake Pawl	1
9	3272-6	Pin - Cotter	2
10	321-2	Screw - Cap Hex. Hd.	1
11	69-7790	Pin - Brake Arm	1
12	32152-1	Nut - Lock	4
13	29-6163	Switch - Micro	1
14	3296-9	Nut - Lock	2

Ref. No.	Part No.	Description	No. Used
15	32152-4	Nut - Lock	2
16	69-7840	Mount - Brake Arm	1
17	32128-20	Nut - Lock	3
18	3234-14	Screw - Cap Hex. Hd.	3
19	49-6171	Pad - Brake Pedal L.H.	1
*	49-6172	Pad - Brake Pedal R.H.	1
20	69-7700	Pedal - Brake	2
21	323-4	Screw - Cap Hex. Hd.	4
22	69-5670	Cable - Brake	2
23	69-7880	Arm - Brake L.H. (Incl. Ref. #1 & 3)	1
24	283-1	Pin - Clevis	2
25	3290-307	Pin - Cotter, Hair	2
26	3249-11	Screw - Machine	2
*	3290-378	Tie - Cable	3

*Not Illustrated

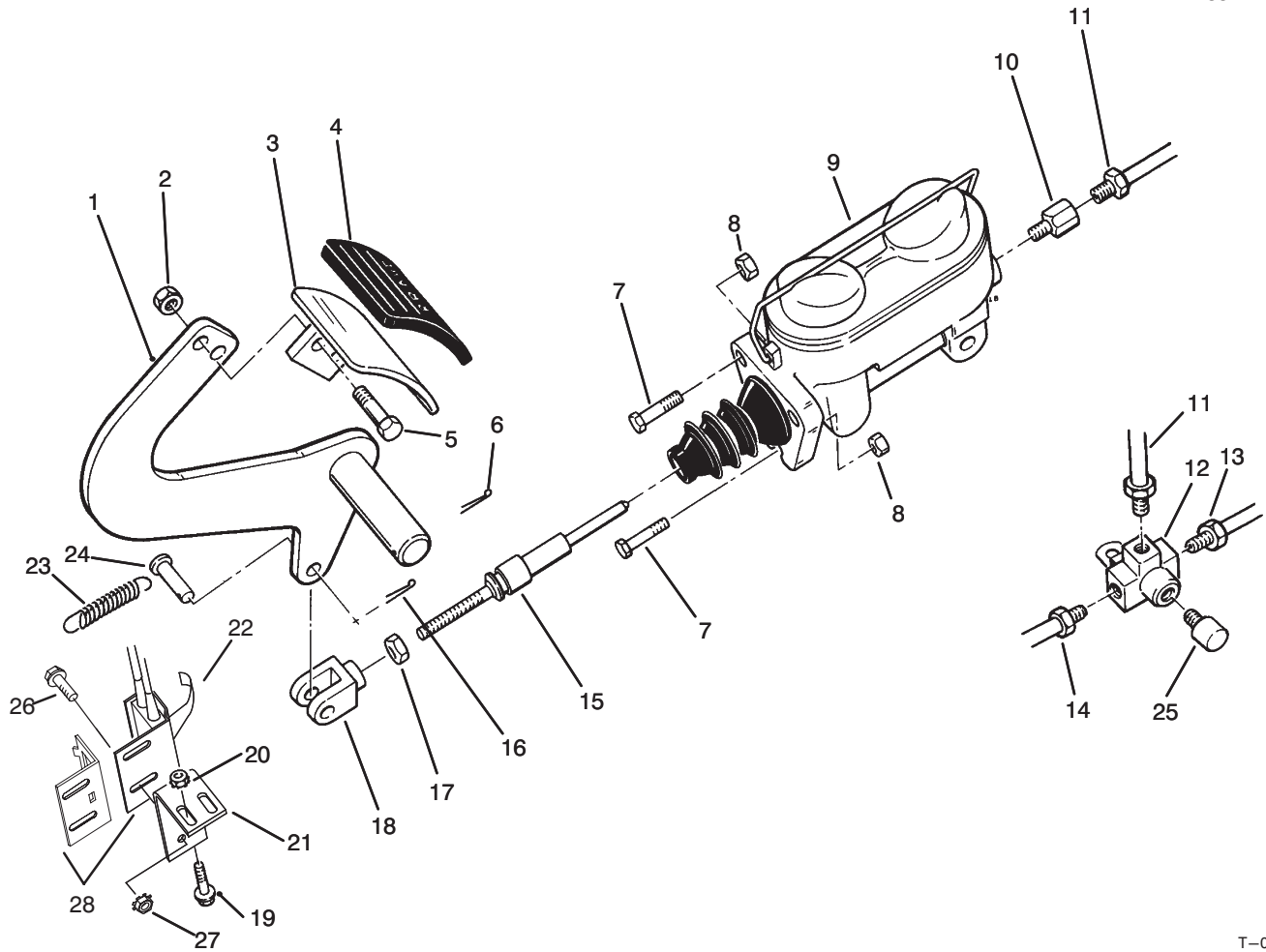

T-0341C

SERVICE BRAKE ASSEMBLY

Ref. No.	Part No.	Description	No. Used	Ref. No.	Part No.	Description	No. Used
1	69-8750	Arm - Brake	1	15	69-9340	Rod - Brake	1
2	32152-1	Nut - Lock	2	16	3272-10	Pin - Cotter	1
3	69-7700	Pedal - Brake	1	17	3220-2	Nut - Jam	1
4	49-6170	Pad - Brake	1	18	282-2	Clevis - Brake Rod	1
5	322-3	Screw - Cap Hex. Hd.	2	19	3234-13	Screw - Hex. Washer Hd.	2
6	3272-12	Pin - Cotter	1	20	32149-2	Nut - Keps	2
7	323-7	Screw - Cap Hex. Hd.	3	21	93-7039	Bracket - Service Brake	1
8	32128-21	Nut - Lock	3	22	93-7037	Switch	1
9	69-2640	Master Cylinder Assembly	1	23	21-1830	Spring - Extension	1
10	353-994	Adapter	1	24	283-1	Pin - Clevis	1
11	74-2530	Tube - Hydraulic	1	25	218-242	Switch - Brake	1
12	218-243	Fitting - Tee	1	26	32144-1	Screw - Hex. Hd.	2
13	74-2510	Tube - Hydraulic L.H.	1	27	32127-11	Nut - Flexlok	2
14	74-2520	Tube - Hydraulic R.H.	1	28	93-9337	Bracket - Switch	1

*Not Illustrated

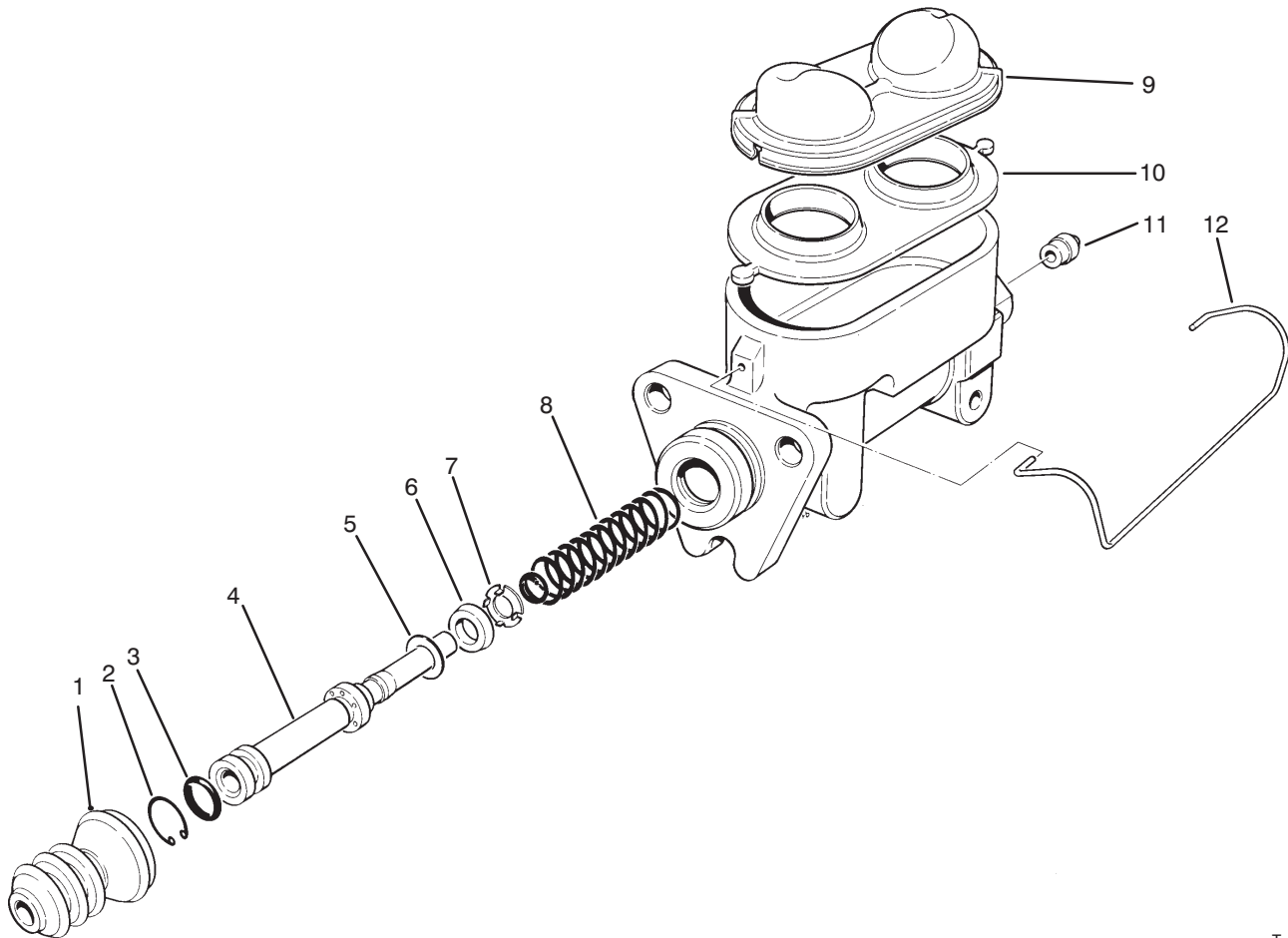

T-0384

BRAKE SYSTEM MASTER CYLINDER NO. 69-2640

Ref. No.	Part No.	Description	No. Used
1	69-2650	Boot - Rod	1
2	69-2660	Ring - Retaining	1
†3		Seal - Lip	1
†4		Piston	1
†5		Protector - Cup	1
†6		Cup - Pumping	1
†7		Retainer - Cup	1

Ref. No.	Part No.	Description	No. Used
†8		Spring - Piston Return	1
9	69-2750	Cover - Reservoir	1
10	69-2760	Gasket - Diaphragm	1
11	69-2770	Seat - Tube	1
12	69-2740	Bail - Cover	1
*	69-2730	Piston Assembly (Incl. Ref. #3-8)	1

*Not Illustrated

†Not serviceable separately.

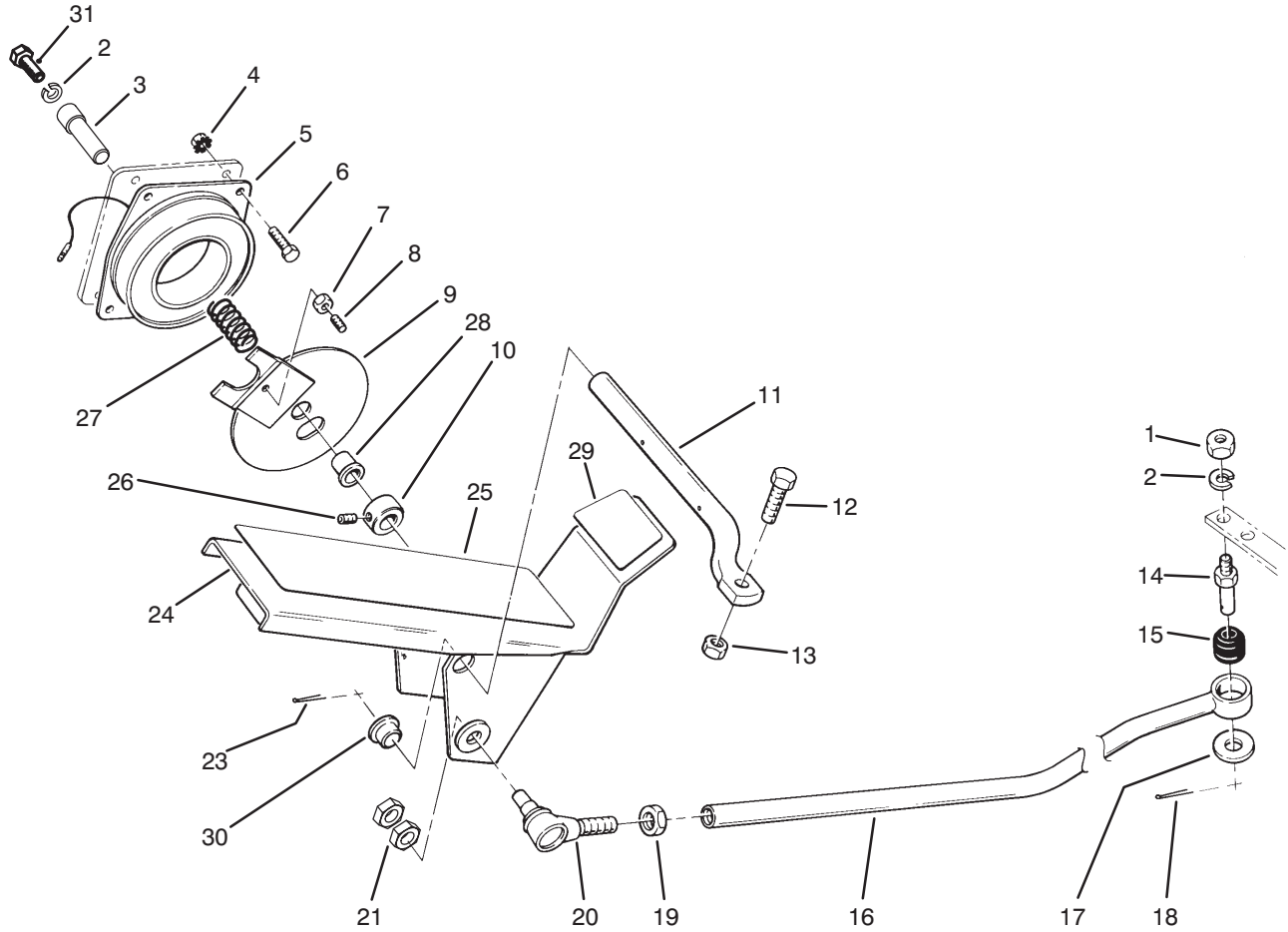

T-0351A

TRACTION PEDAL & CRUISE CONTROL ASSEMBLY

Ref. No.	Part No.	Description	No. Used
1	3217-7	Nut - Lock	1
2	3253-21	Washer - Lock	2
3	92-9701	Shaft - Cruise Control	1
4	32149-2	Nut - Keps	4
5	42-1720	Field Core Coil Assembly	1
6	321-3	Screw - Cap Hex. Hd.	4
7	3217-26	Nut - Lock	1
8	3245-31	Screw - Set	1
9	43-6110	Plate - Clutch	1
10	43-6320	Collar - Locking	1
11	69-9390	Shaft - Pedal	1
12	3234-14	Screw - Cap Hex. Hd.	1
13	32128-20	Nut - Lock	1
14	69-9030	Post - Neutral Device	1
15	23-2270	Bushing - Rubber	1

Ref. No.	Part No.	Description	No. Used
16	74-2700	Rod - Control	1
17	3256-6	Washer - Flat	1
18	3272-10	Pin - Cotter	1
19	3220-5	Nut - Jam	1
20	21-0141	Joint - Ball	1
21	3220-3	Nut - Jam	2
23	3272-7	Pin - Cotter	2
24	69-7650	Pedal - Traction	1
25	71-0440	Abrasive - Pedal Front	1
26	3245-32	Screw - Set	1
27	43-6200	Spring - Compression	1
28	256-273	Bushing - Flange	1
29	71-0450	Abrasive - Pedal Rear	1
30	256-156	Bushing - Flange	2
31	323-6	Screw - Cap Hex. Hd.	1

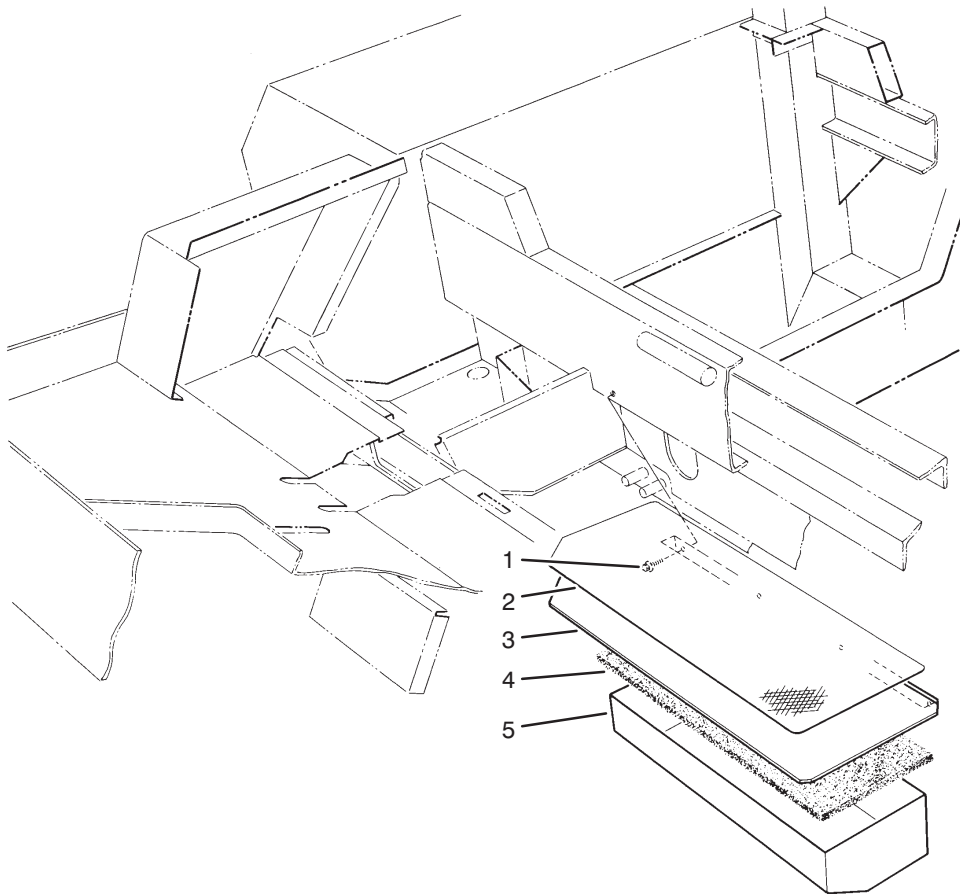

T-0876

TOOL BOX ASSEMBLY

Ref. No.	Part No.	Description	No. Used
1	69-8110	Box - Tool	1
2	69-9430	Foam - Tool Box	1
3	69-8080	Cover - Tool Box	1

Ref. No.	Part No.	Description	No. Used
4	71-0410	Cover - Abrasive	1
5	3234-14	Screw - Hex. Flange Hd.	4

CONTROL BOX ASSEMBLY

Ref. No.	Part No.	Description	No. Used	Ref. No.	Part No.	Description	No. Used
1	69-9560	Housing - Control	1	19	3253-21	Washer - Lock	4
2	3234-7	Screw - Hex. Washer Hd.	11	21	3296-2	Nut - Lock	6
3	80-9330	Alarm - Audio	1	22	92-5720	Controller	1
4	323-4	Screw - Cap Hex. Hd.	4	23	32149-7	Nut - Keps	3
5	88-9430	Decal - Fuse	1	24	67-7160	Block - Fuse	4
6	69-6260	Magnet	1	25	3234-14	Screw - Cap Hex. Hd.	2
7	32105-12	Screw - Hex. Socket Hd.	2	26	69-8210	Support - Cover	1
8	32105-13	Screw - Hex. Hd.	4	27	32128-20	Nut - Flange Lock	2
9	32122-53	Screw - Phil. Truss Hd.	2	32	80-4890	Decal - Service	1
10	43-4000	Breaker - Circuit 40A	1	33	218-581	Fuse - 15A	6
11	3290-133	Screw - Round Hd.	4	34	92-8661	Tab	3
12	3256-22	Washer - Flat	4	35	3229-8	Bolt - Carriage	3
13	69-7040	Holder - Cup	1	36	32149-2	Nut - Keps	3
14	321-3	Screw - Cap Hex. Hd.	4	*	88-9420	Wire Harness Assembly (Incl. Ref. #24)	1
15	3253-3	Washer - Lock	4	*	218-573	Fuse - 5A	1
16	71-2430	Plate - Rear	1	*	3290-378	Tie - Cable	25
17	71-4130	Support - Control	1				
18	3290-378	Tie - Cable	2				

*Not Illustrated

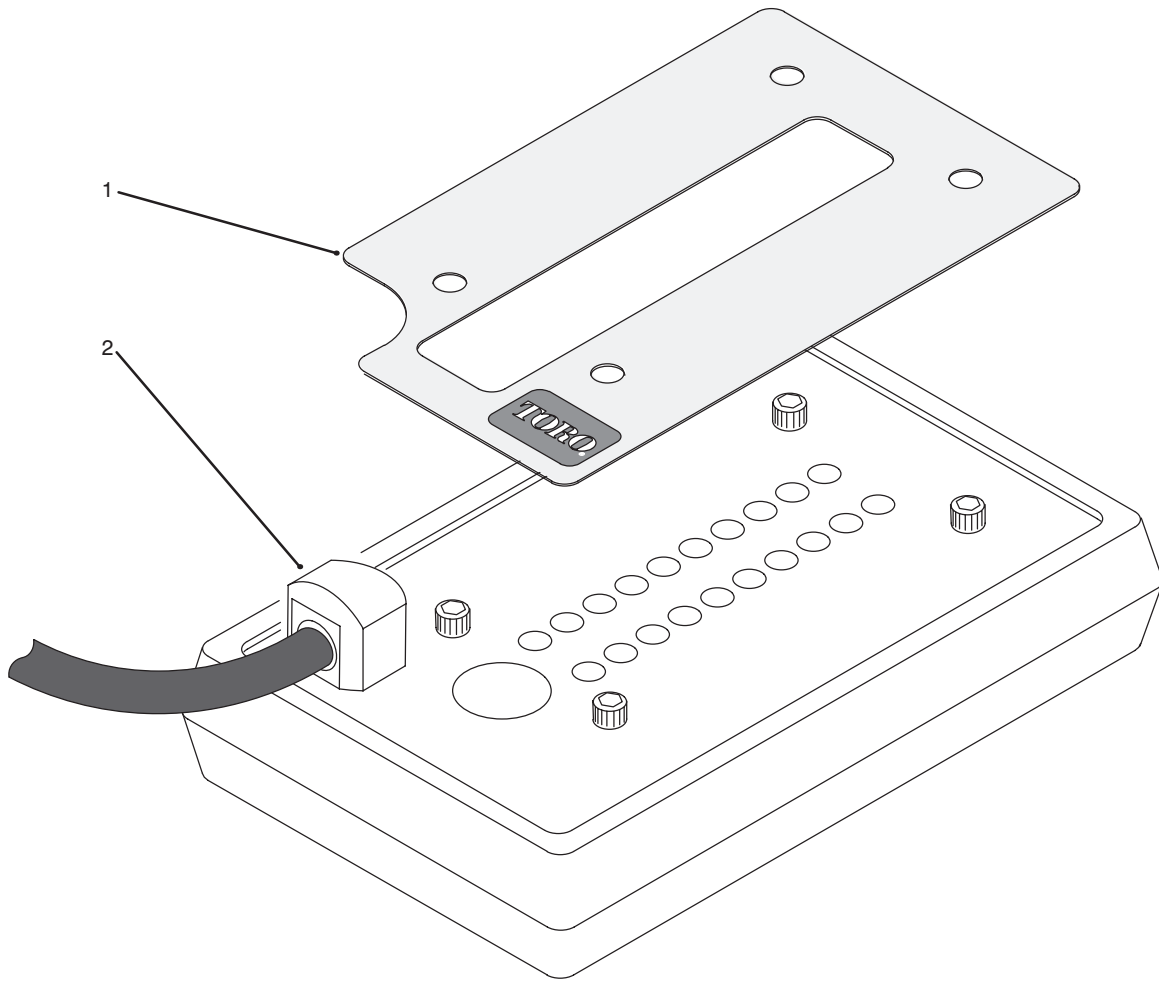

T-1458

DIAGNOSTIC DISPLAY ASSEMBLY

Ref. No.	Part No.	Description	No. Used
1	92-4087	Decal – Diagnostic V2.0 GM 580D	1

Ref. No.	Part No.	Description	No. Used
2	85-4750	Display – Diagnostic	1

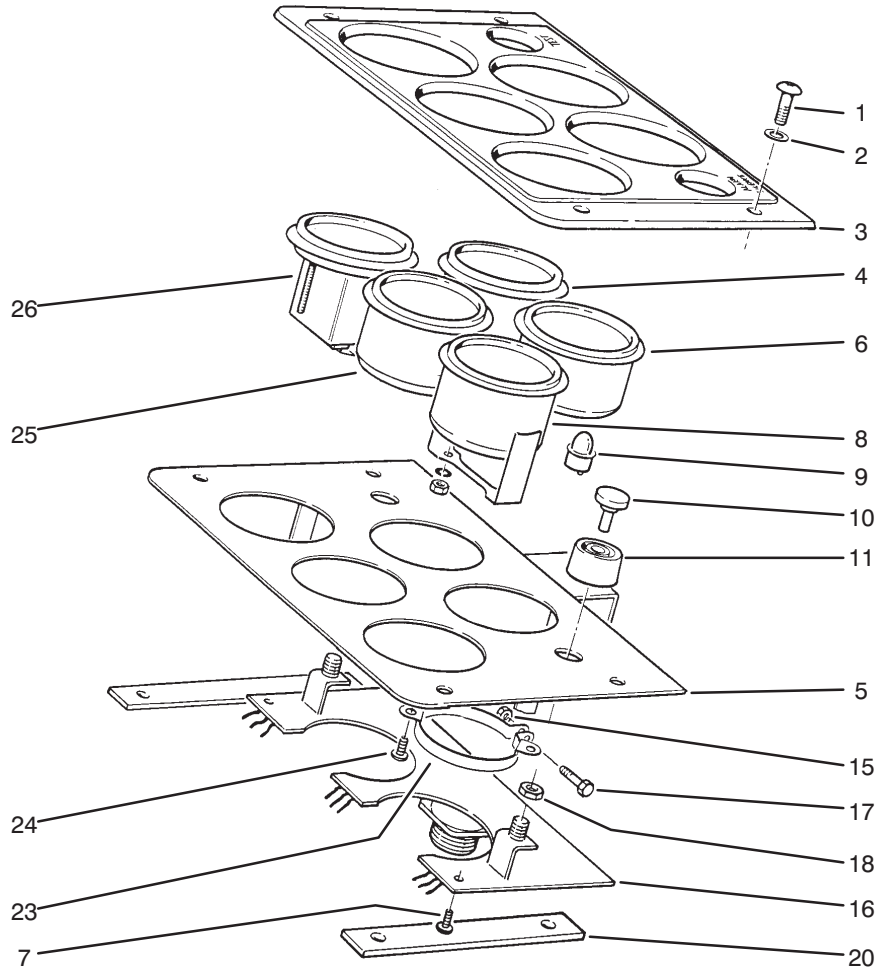

T-1448

UPPER CONTROL PANEL ASSEMBLY

Ref. No.	Part No.	Description	No. Used	Ref. No.	Part No.	Description	No. Used
1	3290-133	Screw - Round Hd.	4	11	43-6420	Bezel	2
2	3256-23	Washer	4	15	3296-2	Nut - Lock	2
3	71-4230	Panel	1	16	92-1771	Board - Instrument	1
4	71-4210	Cluster - Warning Light	1	17	32105-1	Screw - Cap Hex. Hd.	2
5	86-7410	Plate - Gage	1	18	218-498	Nut	2
6	71-4200	Cluster - Warning Light	1	20	71-4250	Spacer	2
7	32104-16	Screw - Tapping	4	23	69-4780	Clamp - Gauge	2
8	63-7430	Gauge - Temperature	1	24	32144-19	Screw - Round Hd.	4
9	219-17	Bulb - Light	8	25	66-2940	Gauge - Fuel	1
10	43-6280	Button	2	26	66-2950	Hourmeter	1

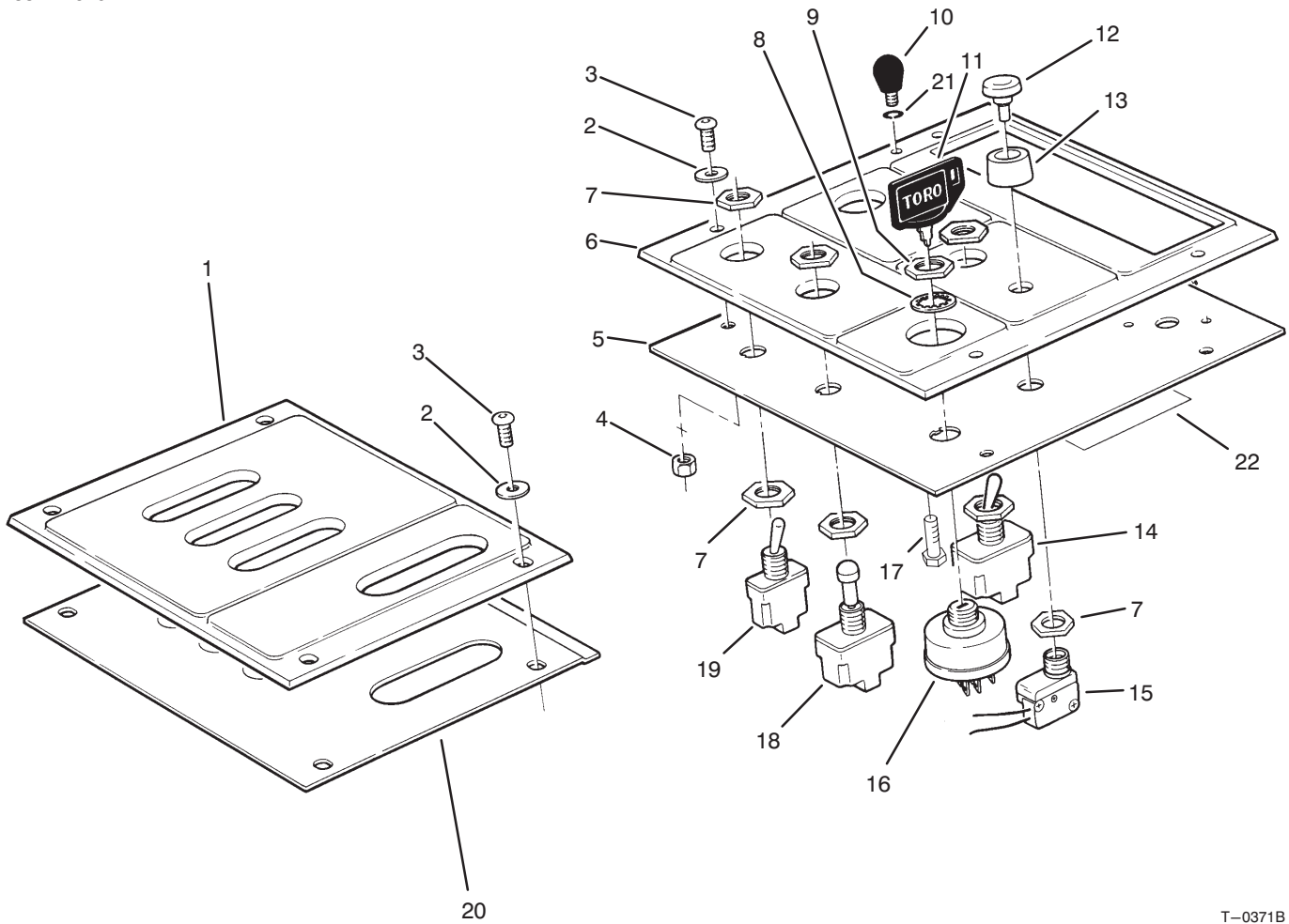

T-0371B

LOWER CONTROL PANEL ASSEMBLY

Ref. No.	Part No.	Description	No. Used
1	69-0980	Panel - Lever	1
2	3256-22	Washer - Flat	8
3	3290-133	Screw - Round Hd.	8
4	3296-42	Nut - Lock	4
5	71-2460	Plate - Control	1
6	69-0990	Panel - Control	1
7	218-498	Nut - Hex	10
8	218-447	Washer - Lock	1
9	218-446	Nut - Hex	1
10	233-66	Knob	1
11	63-8360	Key - Ignition	1
12	43-6280	Button	2
13	43-6420	Bezel	2
14	69-9740	Switch - Toggle (Incl. Ref. #7)	1

Ref. No.	Part No.	Description	No. Used
15	72-9760	Switch (Incl. Ref. #7, 12 & 13)	2
16	27-2360	Switch - Ignition (Incl. Ref. #8 & 9)	1
17	3290-392	Screw - HH	1
18	69-9730	Switch - Toggle (Incl. Ref. #7)	1
19	71-4170	Switch - Toggle (Incl. Ref. #7)	1
20	69-9310	Plate - Lever	1
21	3253-15	Washer - Lock	A/R
22	74-2340	Decal - Fuse	1

ELECTRICAL SCHEMATIC

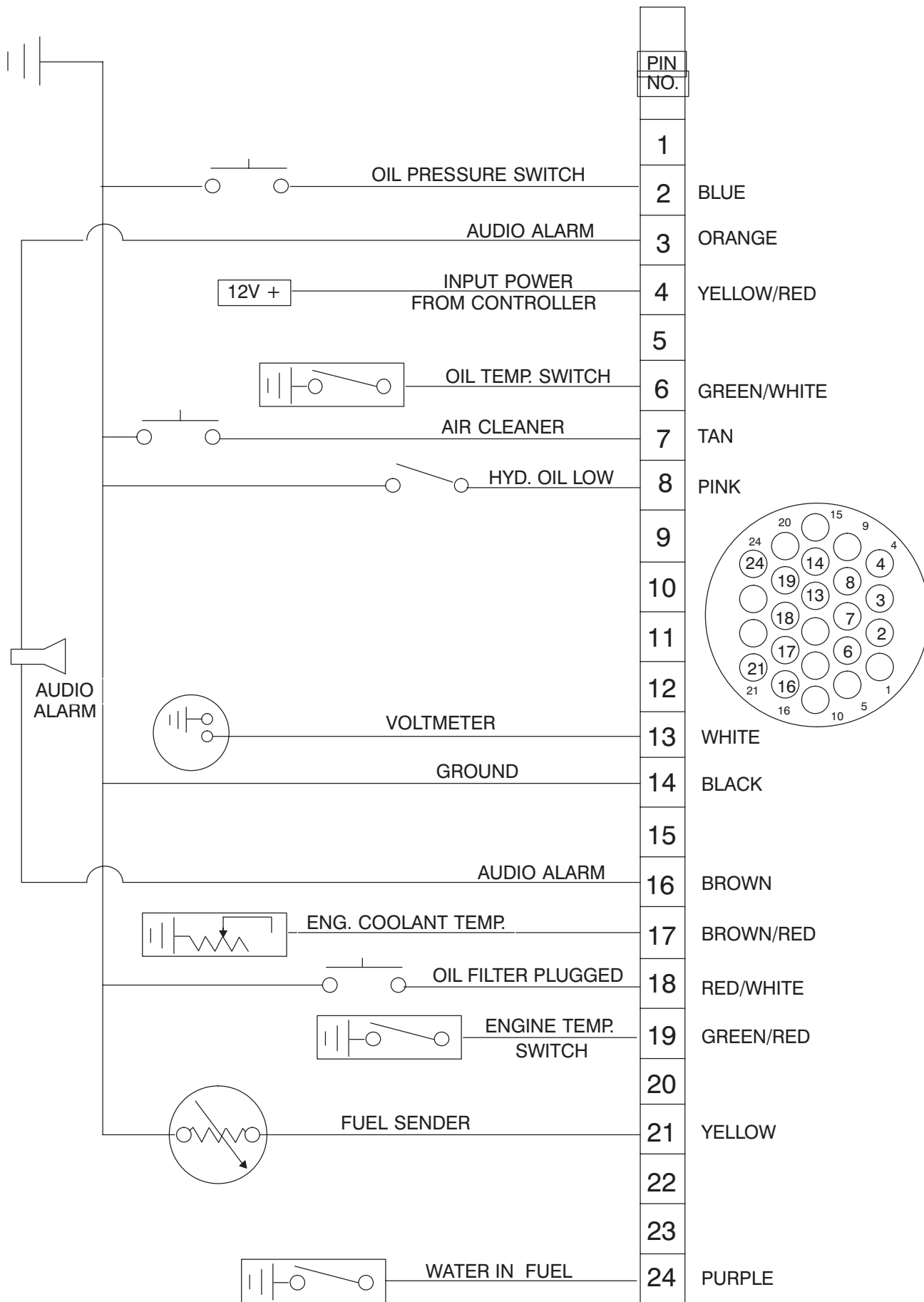

CONTROLLER ELECTRICAL SCHEMATIC

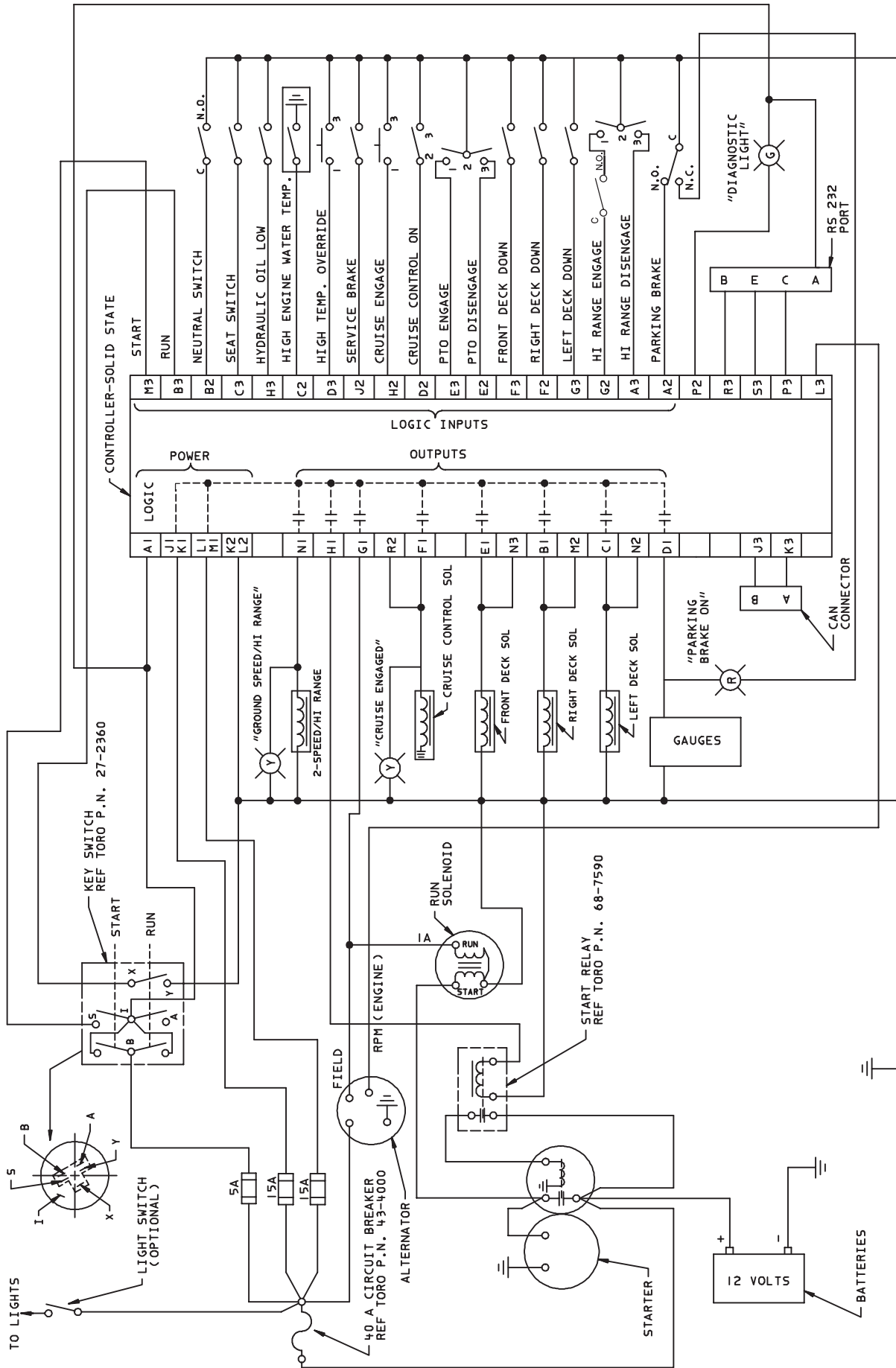

CONNECTION DIAGRAM

OPERATORS CONTROL PANEL ELECTRICAL SCHEMATIC

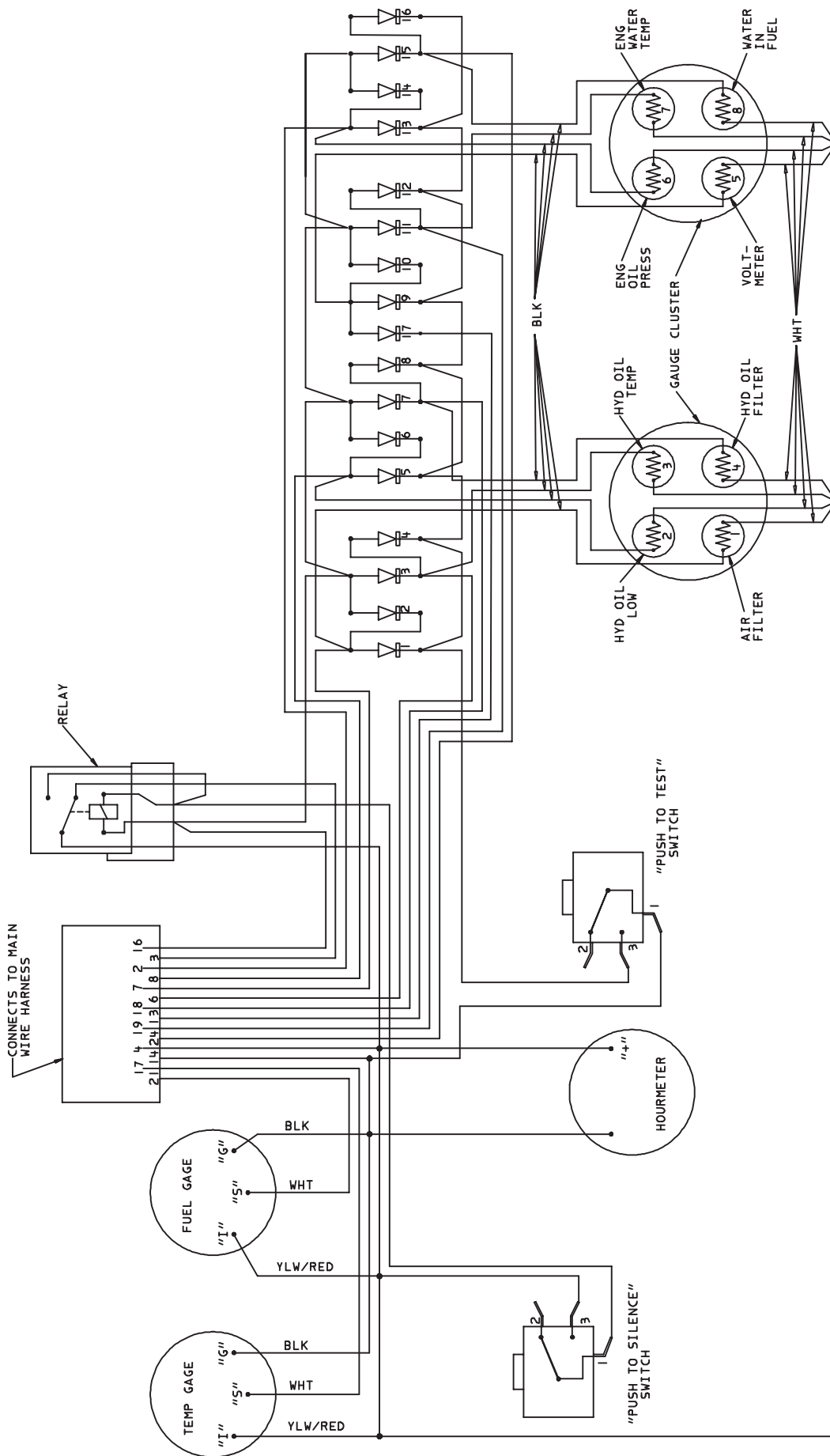

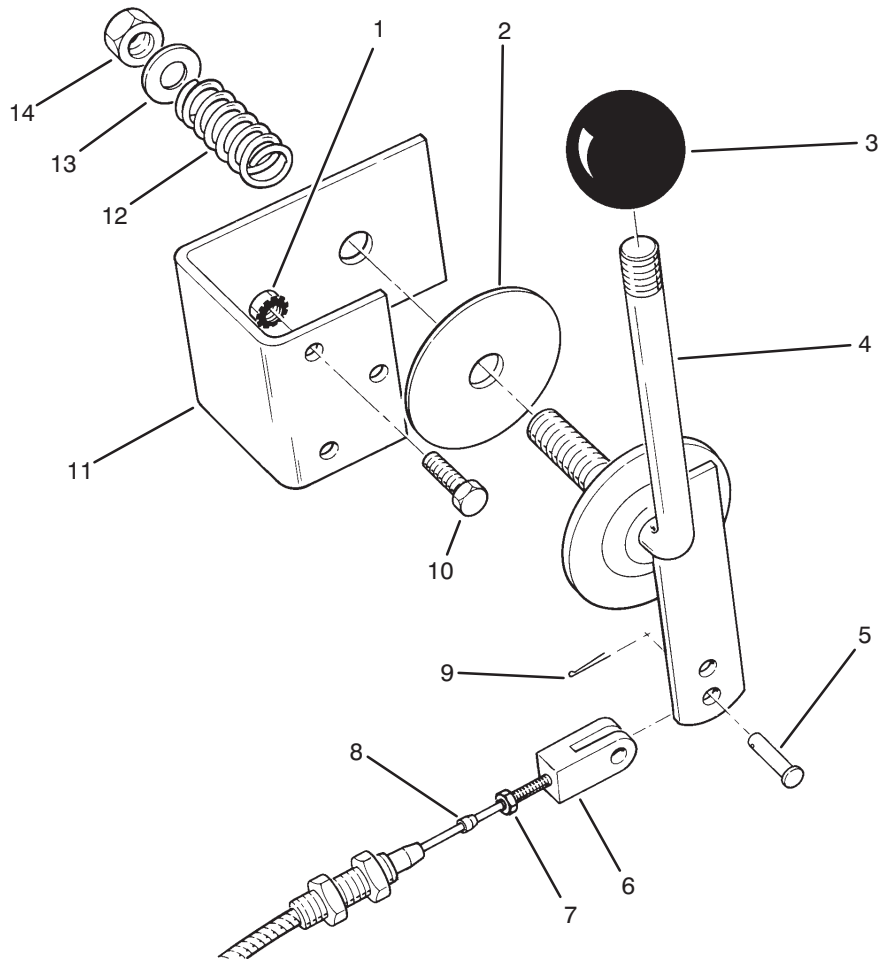

T-0352A

THROTTLE ASSEMBLY

Ref. No.	Part No.	Description	No. Used
1	3296-42	Nut - Keps	3
2	3-2858	Disc - Friction	1
3	233-48	Knob	1
4	69-8040	Arm - Throttle	1
5	283-67	Pin - Clevis Arm End	1
*	69-0090	Pin - Clevis Engine End	1
6	282-28	Clevis - Adjustable	2
7	3219-14	Nut - Hex.	2

Ref. No.	Part No.	Description	No. Used
8	77-2990	Cable - Throttle	1
9	3272-1	Pin - Cotter	3
10	321-3	Screw - Cap Hex. Hd.	3
11	69-9130	Bracket - Throttle	1
12	3-8596	Spring - Compression	1
13	3256-26	Washer - Flat	1
14	3296-23	Nut - Lock	1

*Not Illustrated

LIFT VALVE INSTALLATION ASSEMBLY

Ref. No.	Part No.	Description	No. Used	Ref. No.	Part No.	Description	No. Used
1	321-10	Screw - Cap Hex. Hd.	2	14	237-22	Seal - O-Ring	9
2	69-1780	Lift Valve Assembly	1	15	340-86	Fitting - Hydraulic Tee (Incl. Ref. #14 & 24)	2
3	233-42	Knob	3	16	69-5860	Tube - Hydraulic	1
4	3272-1	Pin - Cotter	6	17	69-5720	Tube - Hydraulic	1
5	69-7010	Lever - Valve L.H.	1	18	69-5700	Tube - Hydraulic	1
*	69-6990	Lever - Valve Mid.	1	19	69-5740	Tube - Hydraulic	1
*	69-7000	Lever - Valve R.H.	1	20	69-5680	Tube - Hydraulic	1
6	69-9140	Link - Valve Lever	3	21	69-5890	Tube - Hydraulic	1
7	32149-2	Nut - Keps	2	22	69-5870	Tube - Hydraulic	1
8	3234-14	Screw - Hex. Flange Hd.	6	23	340-2	Fitting - Hydraulic Straight (Incl. Ref. #14 & 24)	3
9	69-9150	Shaft - Valve Lever	1	24	237-42	Seal - O-Ring	5
10	3272-6	Pin - Cotter	2	25	3254-6	Washer - Lock	1
11	69-7810	Bracket - Valve	1	26	69-4060	Counterbalance Manifold Assembly	1
12	237-79	Seal - O-Ring	2				
13	340-3	Fitting - Hydraulic Straight (Incl. Ref. #12 & 14)	2				

*Not Illustrated

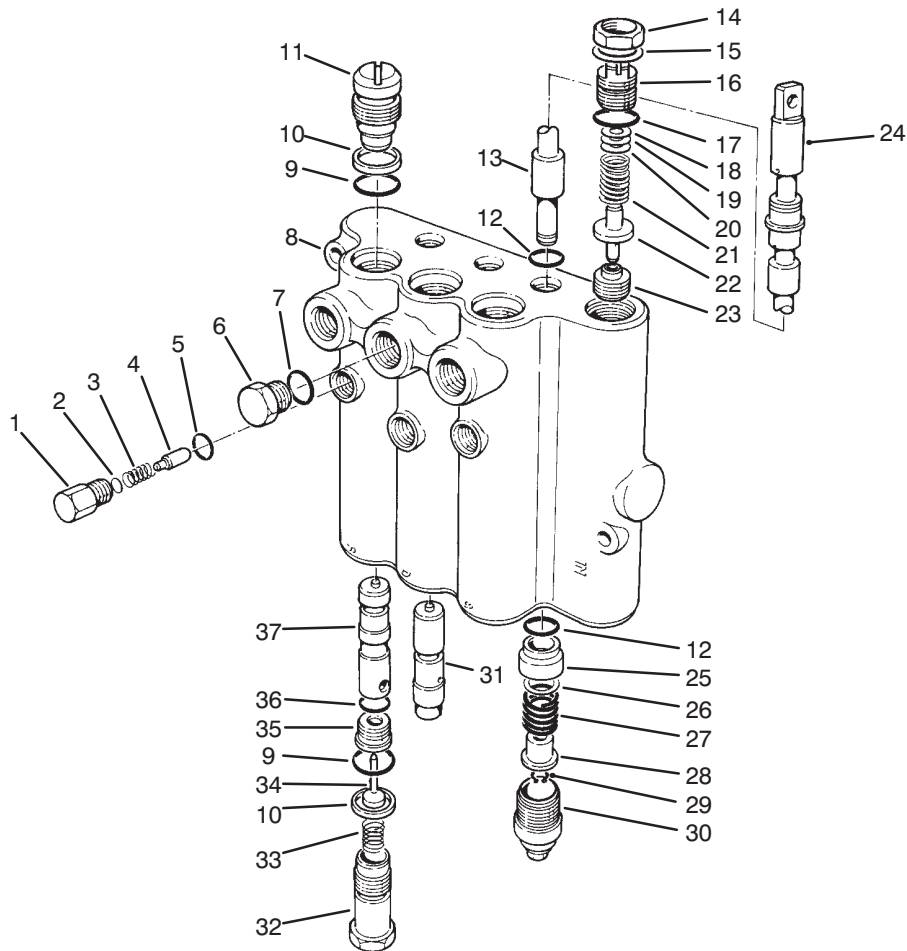

T-0379

LIFT VALVE ASSEMBLY NO. 69-1780

Ref. No.	Part No.	Description	No. Used	Ref. No.	Part No.	Description	No. Used
1	58-6780	Plug Assy. (Incl. Ref. #5)	3	21	69-1820	Spring - Black	1
2	60-6450	Disc	A/R	22	58-6440	Poppet	1
3	58-6760	Spring	3	†23		Seat	1
4	58-6770	Plunger - Detent	3	24	58-6320	Wiper - Seal	3
5	58-6790	Seal - O-Ring	3	25	58-6400	Bushing	3
6	58-6710	Plug Assy. (Incl. Ref. #7)	1	26	58-6700	Washer	3
7	58-6720	Seal - O-Ring	1	27	58-6730	Spring	3
†8		Body	1	28	58-6310	Spacer	3
9	60-5720	Seal - O-Ring	6	29	58-6460	Ring - Retaining	3
10	58-6370	Washer - Back-Up	6	30	58-6420	Cap Assembly	3
11	58-6350	Plug Assembly (Incl. Ref. #9-10)	3	31	69-1840	Plunger	1
12	58-6450	Seal - O-Ring	6	32	69-1800	Plug Assembly (Incl. Ref. #9-10)	3
†13		Spool	3	33	69-1810	Spring	3
14		Nut - Lock	1	34	58-6290	Poppet Assembly	3
15		Washer	1	35	58-6330	Seat Assy. (Incl. Ref. #36)	3
16	69-1830	Plug Assembly (Incl. Ref. #14, 15 & 17)	1	36	58-6340	Seal - O-Ring	3
17	58-6750	Seal - O-Ring	1	37	69-1790	Plunger	2
18	58-6470	Washer	A/R	*	60-3780	Seal Kit (Incl. Ref. #5, 7, 9, 10, 12, 17, 24, 29, 34, & 36)	
19	58-6480	Washer	A/R				
20	58-6490	Washer	A/R				

*Not Illustrated

†Not Serviceable Separately

T-0356A

COUNTERBALANCE MANIFOLD ASSEMBLY

Ref. No.	Part No.	Description	No. Used
1	69-4080	Valve - Hydraulic Cartridge (Incl. Ref. #2)	1
2	75-2080	Kit - Seal	2
3	353-990	Plug - Hose (Incl. Ref. #4)	2
4	237-78	Seal - O-Ring	2
5	69-5890	Tube - Hydraulic	1
6	237-21	Seal - O-Ring	2
7	340-92	Fitting - Hydraulic Straight (Incl. Ref. #6 & 8)	2
8	237-78	Seal - O-Ring	3
9	69-5680	Tube - Hydraulic	1
10	69-4120	Valve - Hydraulic Cartridge (Incl. Ref. #11)	1
11	69-4240	Kit - Seal	1
12	353-991	Plug - Hole (Incl. Ref. #13)	8
13	237-156	Seal - O-Ring	8
14	69-4070	Manifold - Counter Balance	1
15	69-4100	Valve - Hydraulic Cartridge (Incl. Ref. #2)	1
16	353-566	Tee - Hydraulic (Incl. Ref. #8)	1
17	92-4967	Tube - Hydraulic	1
18	69-5850	Tube - Hydraulic	1
19	69-5910	Tube - Hydraulic	1
20	69-5710	Tube - Hydraulic	1
21	237-22	Seal - O-Ring	7

Ref. No.	Part No.	Description	No. Used
22	237-30	Seal - O-Ring	2
23	340-4	Fitting - Hydraulic Straight (Incl. Ref. #22 & 24)	2
24	237-79	Seal - O-Ring	2
25	93-7192	Hose - Hydraulic Diagnostic	1
26	340-2	Fitting - Hydraulic Straight (Incl. Ref. #21 & 27)	5
27	237-42	Seal - O-Ring	6
28	69-5870	Tube - Hydraulic	1
29	69-4250	Kit - Seal	3
30	69-4110	Valve - Hydraulic Cartridge (Incl. Ref. #29)	2
31	69-5820	Tube - Hydraulic	1
32	69-5830	Tube - Hydraulic	1
33	69-5730	Tube - Hydraulic	1
34	69-5860	Tube - Hydraulic	1
35	340-94	Tee - Hydraulic (Incl. Ref. #21 & 27)	1
36	69-4090	Valve - Hydraulic Cartridge (Incl. Ref. #29)	1
37	69-5920	Tube - Hydraulic	1
*	69-4060	Counterbalance Manifold (Incl. Ref. #1-4, 10-15, 29, 30 & 36)	1
38	69-4140	Plug - Orifice .120	1
39	69-4130	Plug - Orifice .047	2

*Not Illustrated

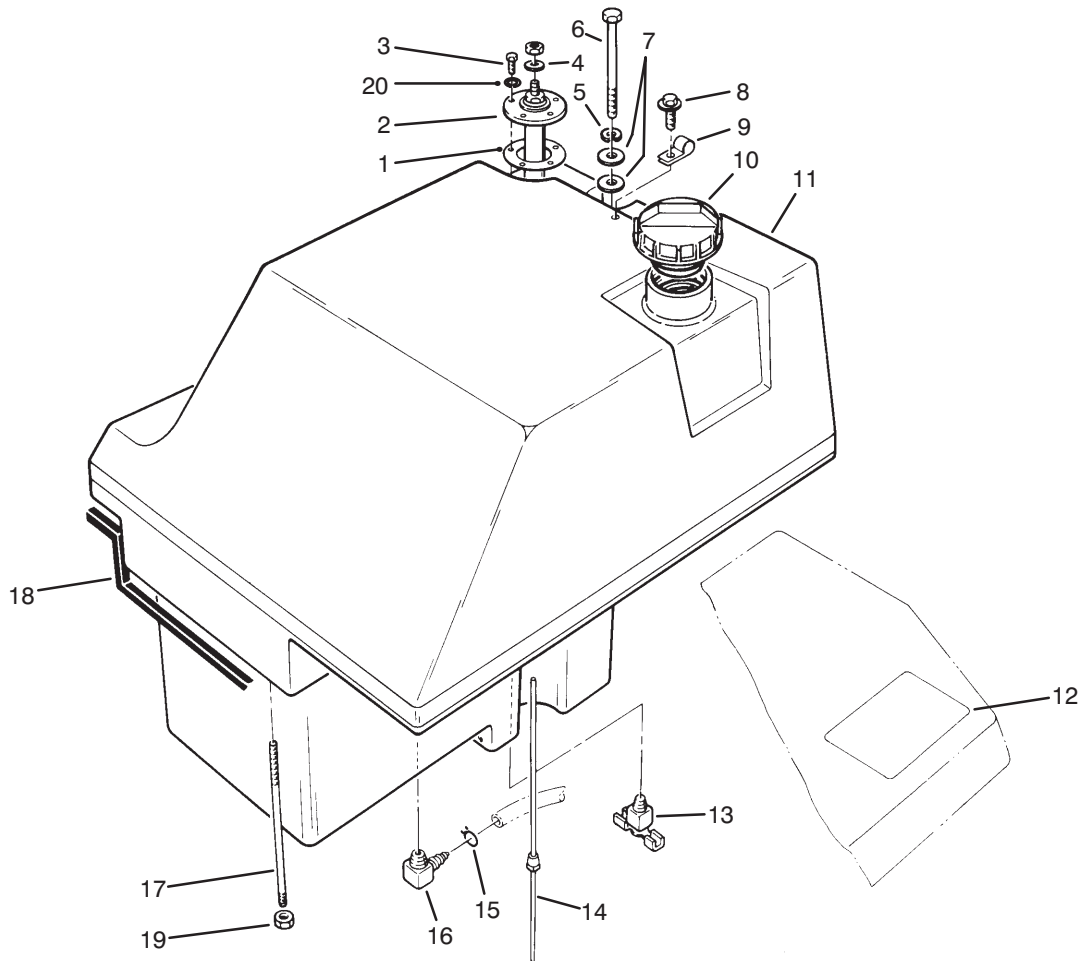

T-0353B

FUEL TANK ASSEMBLY

Ref. No.	Part No.	Description	No. Used	Ref. No.	Part No.	Description	No. Used
1	62-7650	Gasket - Level Sensing Unit	1	11	80-0010	Tank - Fuel	1
2	70-6990	Level Sensing Unit Assembly	1	12	69-0930	Decal - Warning	1
3	32122-24	Screw - Cap Hex. Hd.	5	13	304-46	Drain - Fuel Tank	1
4	5-3637	Spacer - Terminal	1	14	69-7200	Tube - Vent	1
5	3253-21	Washer - Lock	2	15	2412-6	Clamp - Hose	1
6	323-21	Screw - Cap Hex. Hd.	1	16	353-536	Fitting - Fuel 90° Elbow	1
7	3256-5	Washer - Flat	2	17	72-9550	Stud - Fuel Tank	1
8	3234-13	Screw - Hex. Washer Hd.	1	18	68-7572	Strip - Sealing	1
9	2412-89	Clamp - R	1	19	3217-7	Nut - Hex.	1
10	93-3102	Cap - Fuel	1	20	3253-15	Washer - Lock	5

T-0354A

HYDRAULIC TANK ASSEMBLY

Ref. No.	Part No.	Description	No. Used
1	237-81	Seal - O-Ring	1
2	69-1170	Gauge - Sight (Incl. Ref. #1)	1
3	85-6260	Level Sensing Unit	1
4	77-5390	Tank - Hydraulic	1
5	323-10	Screw - Cap Hex. Hd.	4
6	3253-21	Washer - Lock	4
7	5-3177	Washer - Flat	4
8	69-1610	Adapter - Suction Hose	1
9	3253-3	Washer - Lock	10
10	321-5	Screw - Cap Hex. Hd.	10
11	2412-34	Clamp - Hose	1
12	69-5640	Hose - Suction	1
13	2412-42	Clamp - Hose	4
14	69-5370	Hose - Auxiliary Suction	1
15	2412-3	Clamp - Hose	1
16	237-157	Seal - O-Ring	1
17	69-1650	Screen - Suction	1

Ref. No.	Part No.	Description	No. Used
18	340-130	Fitting - Hydraulic 90° (Incl. Ref. #19 & 21)	1
19	237-80	Seal - O-Ring	3
20	69-5800	Tube - Hydraulic	1
21	237-22	Seal - O-Ring	2
22	340-3	Fitting - Hydraulic Straight (Incl. Ref. #21 & 23)	1
23	237-79	Seal - O-Ring	1
24	68-7571	Strip - Sealing	1
26	321-2	Screw - Cap, Hex. Hd.	1
27	75-0540	Tether - Cap, Reservoir	1
31	71-2680	Hose - Vent	1
32	2412-108	Clamp - Hose	2
33	69-4280	Tube - Hydraulic Vent	1
34	61-2790	Filler - Screen	1
35	2410-73	Pin - Tether	1
36	93-3103	Cap - Hydraulic (Incl. Ref. #27 & 35)	1
37	92-4970	Hose - Hydraulic	1

HYDRAULIC FILTER ASSEMBLY

Ref. No.	Part No.	Description	No. Used
1	237-80	Seal - O-Ring	1
2	340-22	Fitting - Hydraulic Tee (Incl. Ref. #1 & 3)	1
3	237-65	Seal - O-Ring	2
4	92-4807	Tube - Hydraulic	1
5	237-22	Seal - O-Ring	3
7	237-58	Seal - O-Ring	1
9	2412-92	Clamp - Hose	4
10	69-5410	Manifold - Return (Incl. Ref. #5, 13 & 24)	1
11	69-6000	Tube - Hydraulic (Incl. Ref. #5)	1
12	69-5990	Tube - Hydraulic (Incl. Ref. #5)	1
13	237-30	Seal - O-Ring	2
14	69-5460	Hose - Hydraulic	1
15	39-7593	Temperature Sending Unit	1
16	3253-2	Washer - Lock	1
17	3219-14	Nut - Hex.	1
18	69-5650	Hose - Hydraulic	1
19	69-1700	Hydraulic Filter Assembly (Incl. Ref. #20, 21 & 25-27)	1
20	237-155	Seal - O-Ring	1
21	69-1720	Element - Filter (Incl. Ref. #20)	1

Ref. No.	Part No.	Description	No. Used
22	340-65	Seal - O-Ring	1
23	340-79	Fitting - Hydraulic 90° (Incl. Ref. #22 & 24)	1
24	237-101	Seal - O-Ring	2
25	69-1710	Indicator - Filter (Incl. Ref. # 26 & 27)	1
†26		Seal - O-Ring	1
†27		Seal - O-Ring	1
28	323-4	Screw - Cap Hex. Hd.	3
29	3253-21	Washer - Lock	3
30	69-5440	Hose - Hydraulic	1
31	69-8440	Hose - Hydraulic	1
32	69-5950	Tube - Hydraulic	1
34	74-2660	Hose - Hydraulic Return	1
35	92-2352	Hose - Hydraulic	1
36	92-2351	Fitting - Tank Return (Incl. Ref. #7 & 37)	1
37	340-136	Seal - O-Ring	1
38	340-150	Cap - Hydraulic	1
39	2412-129	Clamp - Hose	1
40	92-1742	Tube - Hydraulic	1
41	32152-1	Nut - Lock	3
42	56-7978	Clamp Half - Hydraulic Line	6
43	69-9761	Plate - Cover	3
44	322-12	Screw - Cap Hex. Hd.	3

†Not serviceable separately.

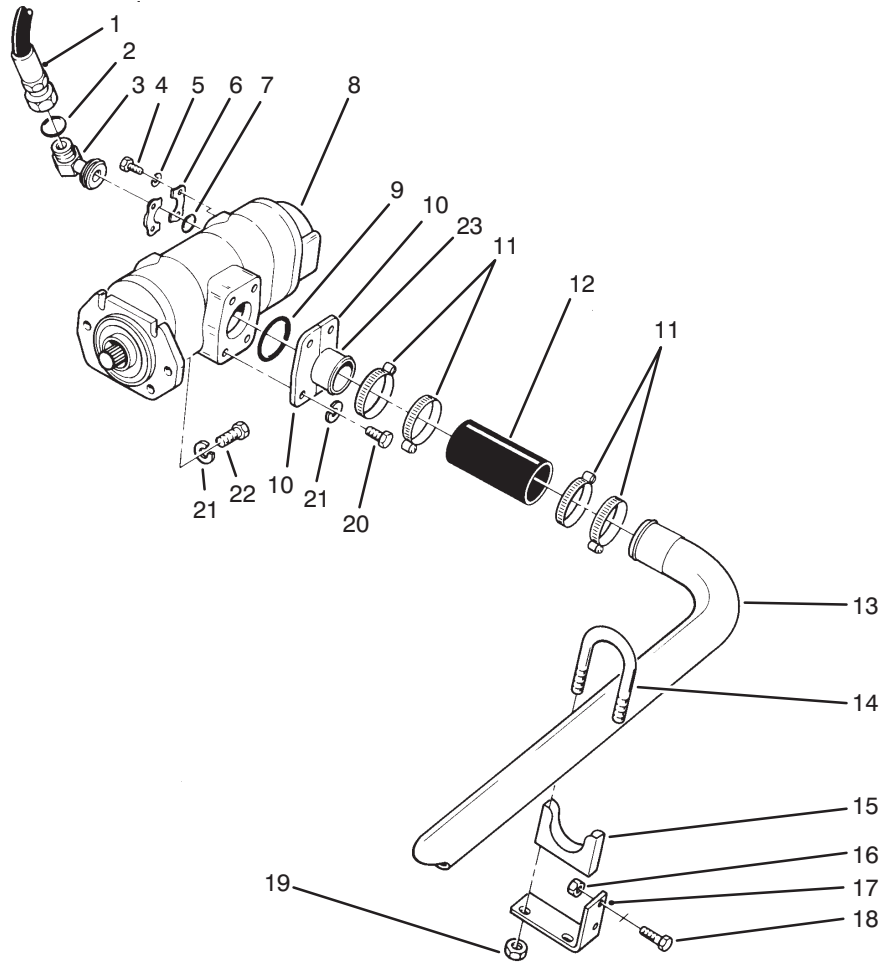

T-0349

HYDRAULIC PUMP INSTALLATION ASSEMBLY

Ref. No.	Part No.	Description	No. Used	Ref. No.	Part No.	Description	No. Used
1	69-5590	Hydraulic Hose Assembly	2	13	69-6110	Hydraulic Tube Assembly	1
2	237-58	Seal - O-Ring	2	†14		Bolt - U	2
3	69-6240	Fitting - Hydraulic 90° (Incl. Ref # 2 & 7)	2	15	20-4840	Clamp - Tube (Incl. Ref. #14 & 19)	2
4	323-7	Screw - Cap Hex. Hd.	8	16	32152-2	Nut - Lock	4
5	3253-21	Washer - Lock	8	17	69-9220	Support - Tube Clamp	2
6	353-992	Flange - Fitting	4	18	323-6	Screw - Cap Hex. Hd.	4
7	340-135	Seal - O-Ring	2	19	32128-25	Nut - Lock	4
8	69-2050	Hydraulic Pump Assembly	1	20	325-6	Screw - Cap Hex. Hd.	4
9	237-116	Seal - O-Ring	1	21	3253-7	Washer - Lock	8
10	354-42	Flange - Half	2	22	3213-2	Screw - Cap Hex. Hd.	4
11	2412-42	Clamp - Hose	4	23	74-2270	Fitting - Suction	1
12	69-5640	Hose - Hydraulic	1				

†Not serviceable separately.

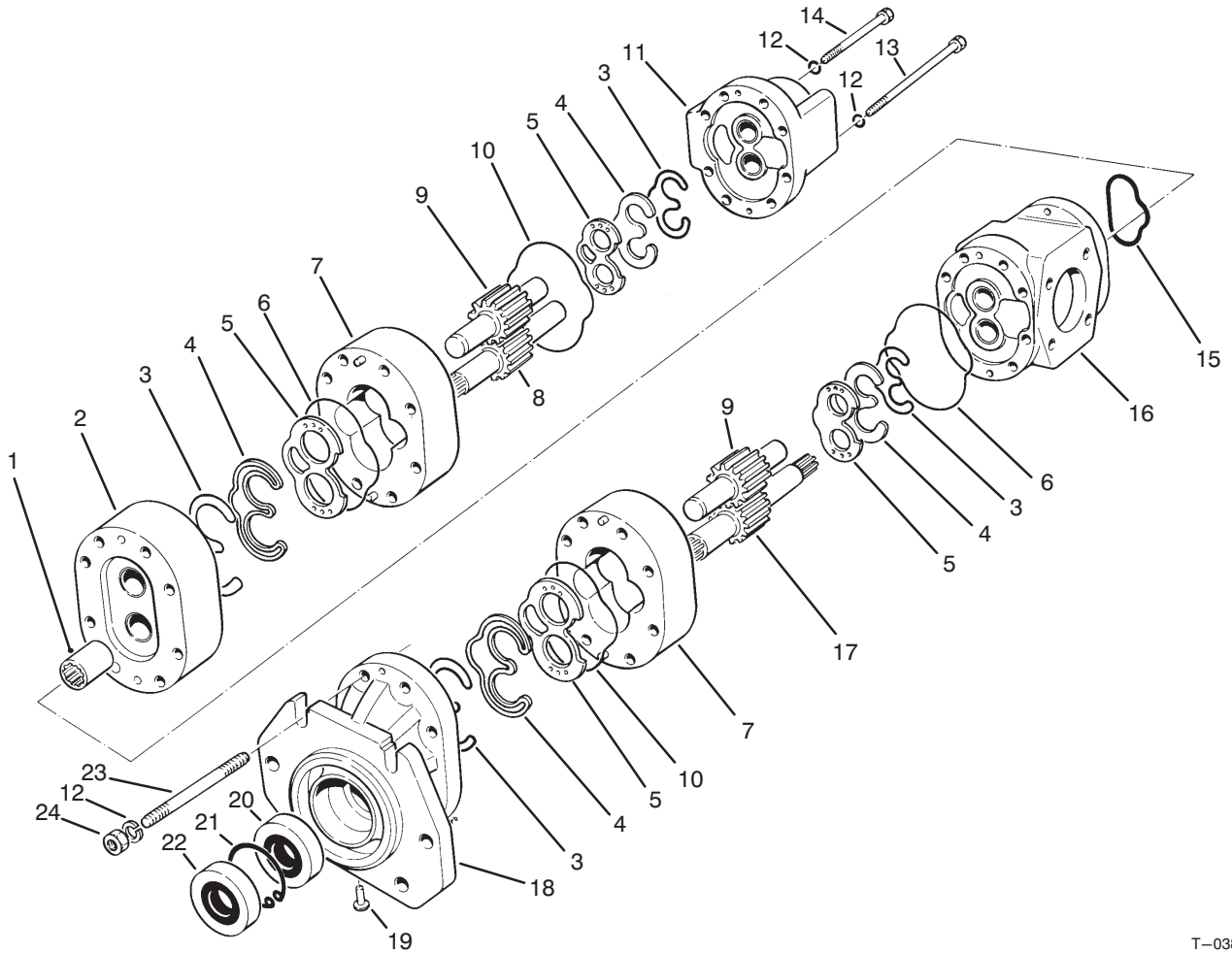

T-0382

DOUBLE GEAR PUMP NO. 69-2050

Ref. No.	Part No.	Description	No. Used
1	69-2110	Coupling	1
2	69-2170	Adapter Section Assembly	1
3	59-7990	Seal - Gland	4
4	59-8470	Retainer - Seal	4
5	69-2070	Plate - Flex	4
6	69-2200	Seal - O-Ring	2
7	69-2080	Center Section Assembly	2
8	69-2090	Gear/Shaft - Rear Drive	1
9	59-8600	Gear - Driven	2
10	69-2120	Seal - O-Ring	2
11	69-2100	Rear Cover Assembly	1
12	59-7590	Washer - Lock	16
13	69-2150	Screw - Cap Hex. Hd.	4

Ref. No.	Part No.	Description	No. Used
14	69-2140	Screw - Cap Hex. Hd.	4
15	69-2210	Seal - O-Ring	1
16	69-2160	Port Section Assembly	1
17	59-8500	Gear/Shaft - Front Drive	1
18	69-2060	Shaft End Cover Assembly	1
19	69-2130	Plug	1
20	59-8590	Seal - Shaft	1
21	59-8580	Ring - Retaining	1
22	59-8570	Seal - Shaft	1
23	59-7970	Stud - Threaded	8
24	59-7580	Nut - Hex.	8
*	59-8610	Repair Kit (Incl. Ref. #3, 4, 20 & 22)	1

FRAME ASSEMBLY

Ref. No.	Part No.	Description	No. Used
1	85-6190	Link - Deck Tilt	1
2	3290-495	Pin - Lynch	2
3	340-126	Nut - Bulkhead	2
4	340-70	Nut - Bulkhead	6
5	69-8940	Washer	12
6	240-4	Grommet	6
7	340-71	Fitting - Hydraulic Bulkhead (Incl. Ref. #32)	1
8	237-30	Seal - O-Ring	3
9	92-4967	Tube - Hydraulic (Incl. Ref. #8)	1
10	3234-28	Screw - Hex. Flange Hd.	2
11	93-7422	Hose - Hydraulic	1
12	353-375	Fitting - Hydraulic 90° (Incl. Ref. #13)	2
13	237-78	Seal - O-Ring	5
14	237-58	Seal - O-Ring	4
15	3274-86	Screw - Cap Socket Hd.	1
16	69-5470	Hose - Hydraulic	1
17	69-5480	Hose - Hydraulic	1
18	237-65	Seal - O-Ring	6
19	93-7177	Assy. - Tube, Traction L.H.	1
20	83-8350	Fitting - Traction, L.H. (Incl. Ref. #14 & 18)	1
21	93-7178	Assy. - Tube, Traction R.H.	1

Ref. No.	Part No.	Description	No. Used
22	69-6200	Tube - Hydraulic (Incl. Ref. #18)	1
23	69-6190	Tube - Hydraulic (Incl. Ref. #18)	1
24	71-2450	Cover - Access	1
25	3234-14	Screw - Hex. Flange Hd.	4
26	69-8930	Washer	4
27	69-8960	Spacer	2
28	240-5	Grommet	2
29	340-127	Nut - Bulkhead	2
30	85-6150	Tube - Hydraulic	1
31	69-8970	Spacer	6
32	237-22	Seal - O-Ring	7
33	69-6050	Tube - Hydraulic (Incl. Ref. #32)	1
34	69-6040	Tube - Hydraulic (Incl. Ref. #32)	1
35	69-6030	Tube - Hydraulic (Incl. Ref. #32)	1
36	32152-1	Nut - Lock	1
37	69-5790	Tube - Hydraulic (Incl. Ref. #8)	1
38	69-6060	Tube - Hydraulic (Incl. Ref. #32)	1
39	93-7426	Tube - Hydraulic (Incl. Ref. #32)	1

*Not Illustrated

FRAME ASSEMBLY (Continued)

Ref. No.	Part No.	Description	No. Used
40	32108-103	Screw - Machine Flat Hd.	4
41	69-9300	Cushion - Rubber	2
42	32152-1	Nut - Lock	4
43	321-9	Screw - Cap Hex. Hd.	2
44	56-7973	Clamp Half - Hydraulic Line	4
45	32152-4	Nut - Lock	2
46	256-247	Bushing - Flange	2
47	240-7	Grommet	4
48	302-5	Fitting - Grease	1
49	69-0100	Frame - Assembly (Incl. Ref. #46 & 48)	1
50	69-6100	Tube - Hydraulic Pressure (Incl. Ref. #14)	1
*	69-5810	Tube - Hydraulic Return (Incl. Ref. #14)	1
51	69-8910	Washer	4
52	69-8900	Spacer	2
53	3220-4	Nut	1
54	92-3048	Solenoid Coil Kit	3
55	32149-2	Nut - Keps	2
56	340-92	Fitting - Hydraulic (Incl. Ref. #13 & 58)	1
57	69-5950	Tube - Hydraulic	1
58	237-21	Seal - O-Ring	3
59	340-125	Fitting - Hydraulic (Incl. Ref. #13 & 58)	1

Ref. No.	Part No.	Description	No. Used
†60		Body - Valve	1
61	93-9988	Fitting - Hydraulic (Incl. Ref. #13)	1
62	92-3047	Valve - Solenoid (Incl. Ref. #53)	1
63	69-9470	Cover - Access	1
64	71-0430	Cover - Abrasive	1
65	321-11	Screw - Cap Hex. Hd.	2
66	71-0420	Floor - Abrasive	1
67	3256-56	Washer - Flat	2
68	3256-23	Washer - Flat	2
69	93-7424	Hose - Diagnostic	1
70	93-7193	Hose - Diagnostic	1
71	72-4080	Decal - Danger	2
72	2410-10	Plug - Button	1
73	83-8360	Fitting - Traction, R.H.	1
74	83-8370	Plate - Clamp	1
77	93-7038	Switch	1
80	92-4970	Hose - Hydraulic	1
81	93-7192	Hose - Diagnostic	1
82	83-4330	Assy. - Tube, Traction LH	1
83	83-4340	Assy. - Tube, Traction RH	1
*	92-3049	Valve Seal Kit	1
*	71-2630	Solenoid Valve Assembly (Incl. Ref. #53, 54, 60, 62 & Valve Seal Kit #92-3049)	1

*Not Illustrated

†Not serviceable separately.

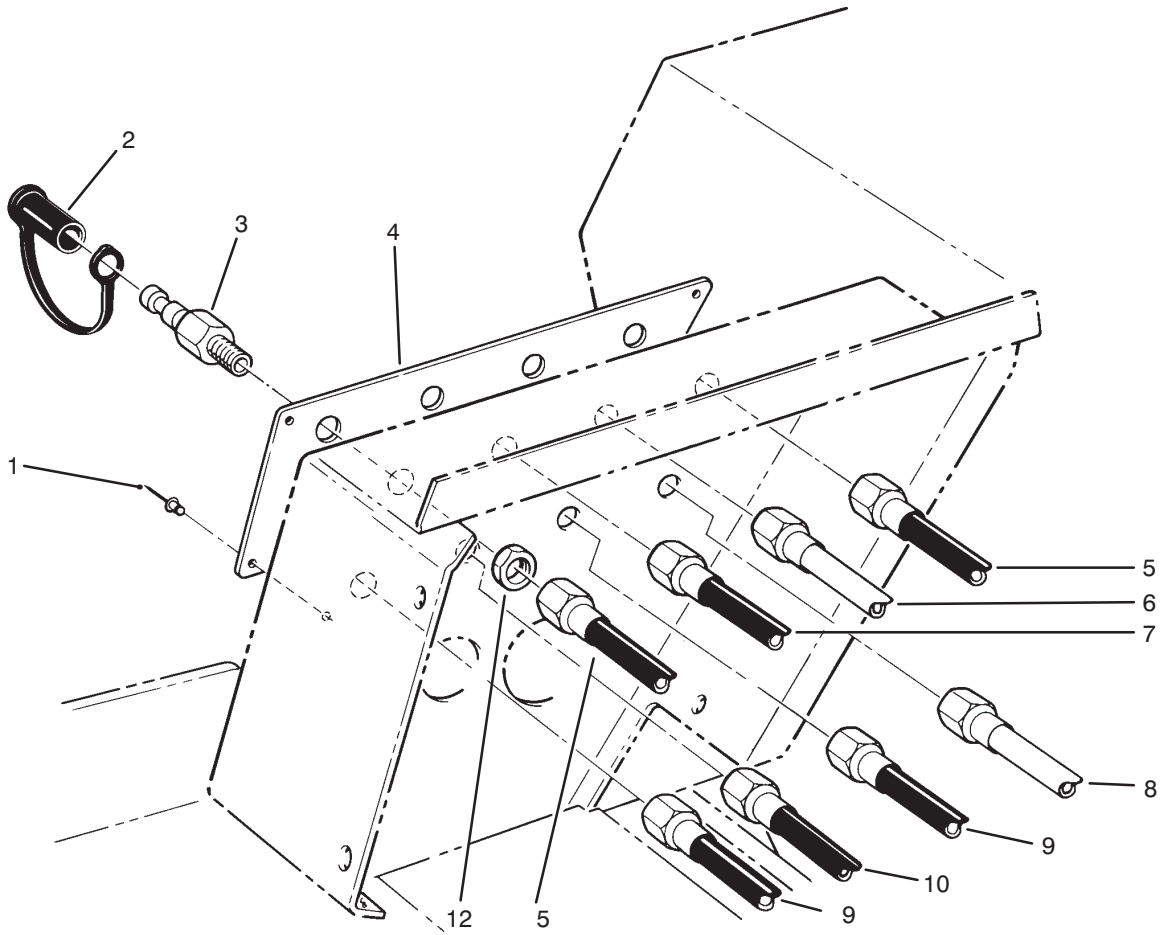

T-0363B

HYDRAULIC SYSTEM DIAGNOSTIC PANEL ASSEMBLY

Ref. No.	Part No.	Description	No. Used
1	3269-25	Rivet - Pop	4
2	353-947	Cap - Fitting	8
3	353-997	Fitting - Hydraulic Bulkhead (Incl. Ref. #12)	8
4	69-0960	Panel - Diagnostic	1
5	93-7422	Hose - Hydraulic Diagnostic	1

Ref. No.	Part No.	Description	No. Used
6	69-5910	Tube - Hydraulic Diagnostic	1
7	93-7193	Hose - Hydraulic Diagnostic	1
8	69-5920	Tube - Diagnostic	1
9	93-7423	Hose - Hydraulic Diagnostic	2
10	93-7425	Hose - Hydraulic Diagnostic	1
12	3220-4	Nut - Bulkhead	8

HYDRAULIC LINE CLAMPS ASSEMBLY

Ref. No.	Part No.	Description	No. Used
1	69-9330	Cover	1
2	3234-14	Screw - Hex. Flange Hd.	6
3	340-128	Nut - Bulkhead	2
4	69-8920	Washer	4
5	69-8950	Spacer	2
6	240-2	Grommet	2
7	237-164	Grommet	1
8	69-0920	Decal - Hydraulic Oil	1
9	322-12	Screw - Cap Hex. Hd.	4
10	69-9760	Plate - Cover	3
11	3256-22	Washer - Flat	2
12	32152-4	Nut - Lock	6
13	32152-1	Nut - Lock	8
14	69-9761	Plate - Cover	5
15	69-6130	Tube - Hydraulic	1
16	69-6120	Tube - Hydraulic	1
17	56-7974	Clamp Half - Hydraulic Line	2
18	321-15	Screw - Cap Hex. Hd.	2
19	56-7973	Clamp Half - Hydraulic Line	20
20	56-7972	Clamp Half - Hydraulic Line	4
21	3256-56	Washer - Flat	8
22	321-9	Screw - Cap Hex. Hd.	6

Ref. No.	Part No.	Description	No. Used
23	322-21	Screw - Cap Hex. Hd.	3
24	3256-23	Washer - Flat	1
25	56-7978	Clamp Half - Hydraulic Line	8
26	56-7971	Clamp Half - Hydraulic Line	2
27	93-7179	Tube - Hydraulic (Incl. Ref. #29)	1
28	69-5800	Tube - Hydraulic (Incl. Ref. #29)	1
29	237-21	Seal - O-Ring	4
30	69-8980	Washer	8
31	240-6	Grommet	4
32	240-7	Grommet	1
33	69-8990	Spacer	4
34	340-78	Nut - Bulkhead	4
35	69-6080	Tube - Hydraulic (Incl. Ref. #29)	1
36	69-6070	Tube - Hydraulic (Incl. Ref. #29)	1
37	32128-20	Nut - Lock	4
38	71-2560	Support - Bulkhead	2
39	69-0940	Decal - Caution	1

HYDRAULIC SCHEMATIC

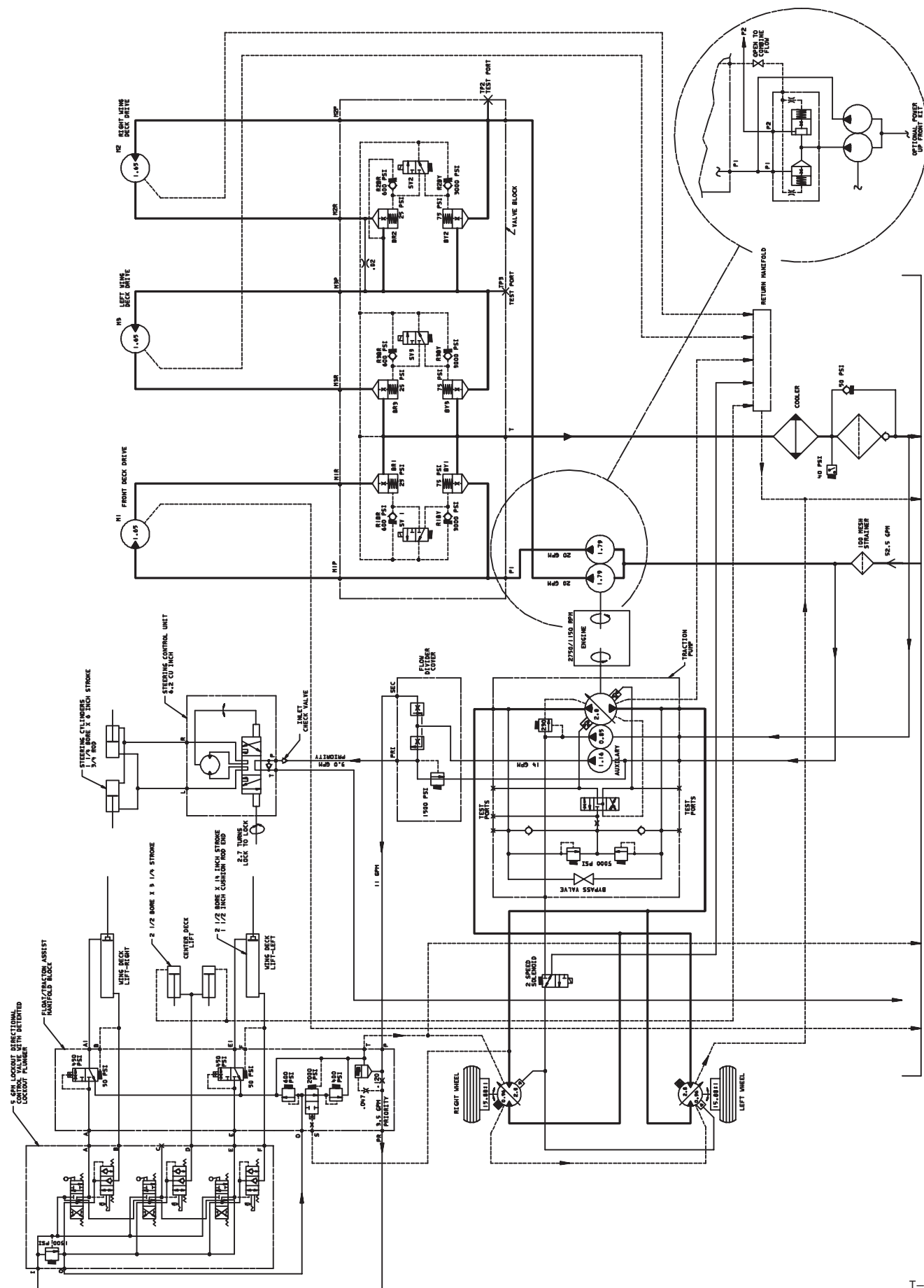

FRONT WHEEL ASSEMBLY

Ref. No.	Part No.	Description	No. Used	Ref. No.	Part No.	Description	No. Used
1	237-42	Seal - O-Ring	2	21	237-158	Seal - O-Ring	4
2	69-5940	Tube - Hydraulic L.H.	1	22	253-156	Seal - Oil	2
*	69-5930	Tube - Hydraulic R.H.	1	23	251-340	Bearing - Ball	2
3	237-21	Seal - O-Ring	2	24	32120-22	Ring - Retaining Internal	2
4	340-82	Fitting - Hydraulic Elbow (Incl. Ref. #1 & 3)	2	25	302-39	Vent	2
5	237-146	Seal - O-Ring	4	26	3253-8	Washer - Lock	16
6	340-91	Fitting - Hydraulic Straight (Incl. Ref. #5 & 7)	2	27	327-22	Screw - Cap Hex. Hd.	16
7	237-58	Seal - O-Ring	7	28	69-9800	Tire	2
8	83-4330	Tube - Hydraulic L.H.	1	*	58-5620	Tube - Inner	2
*	83-4340	Tube - Hydraulic R.H.	1	*	231-140	Tire - (Optional)	2
9	237-81	Seal - O-Ring	4	29	71-2470	Rim	2
10	340-9	Fitting - Hydraulic St. L.H. (Incl. Ref. #7 & 9)	1	30	3253-7	Washer - Lock	22
*	340-148	Fitting - Hydraulic Tee R.H. (Incl. Ref. #7 & 9)	1	31	3219-5	Nut - Hex.	18
12	92-1742	Tube - Hydraulic L.H.	1	32	69-1730	Planetary Gear Drive Assy.	2
*	92-4807	Tube - Hyd. R.H. Run	1	33	32120-84	Ring - Retaining External	2
*	85-6150	Tube - Hyd. R.H. Branch	1	34	71-3810	Coupling - Hydraulic Motor	2
13	71-4010	Housing - Brake	2	35	69-9970	Stud	4
14	3272-6	Pin - Cotter	2	36	69-9960	Link	4
15	71-3880	Clevis - Brake Cable	2	37	69-9950	Spring - Extension	4
16	283-2	Pin - Clevis	2	38	69-9990	Disc - Actuating	4
17	3253-21	Washer - Lock	14	39	69-9980	Ball	6
18	323-6	Screw - Cap Hex. Hd.	14	40	69-9940	Nut - Jam	4
19	71-0470	Disc - Middle	4	41	253-157	Ring - Cup	8
20	71-3990	Cap - Brake Housing	2	42	92-1741	Tube - Hydraulic	1
				43	340-142	Fitting - Hydraulic Elbow (Incl. Ref. #9 & 11)	2
				44	69-3050	Motor - Hydraulic Wheel	2
				45	3256-26	Washer - Flat	4

*Not Illustrated

FRONT WHEEL ASSEMBLY (Continued)

Ref. No.	Part No.	Description	No. Used
46	325-7	Screw - Cap Hex. Hd.	4
47	72-4070	Decal - Danger	2
48	93-7176	Fitting - 45° ORFS	2

Ref. No.	Part No.	Description	No. Used
49	237-65	O-Ring	2
50	93-7177	Tube - Hydraulic, LH	1
*	93-7178	Tube - Hydraulic, RH	1

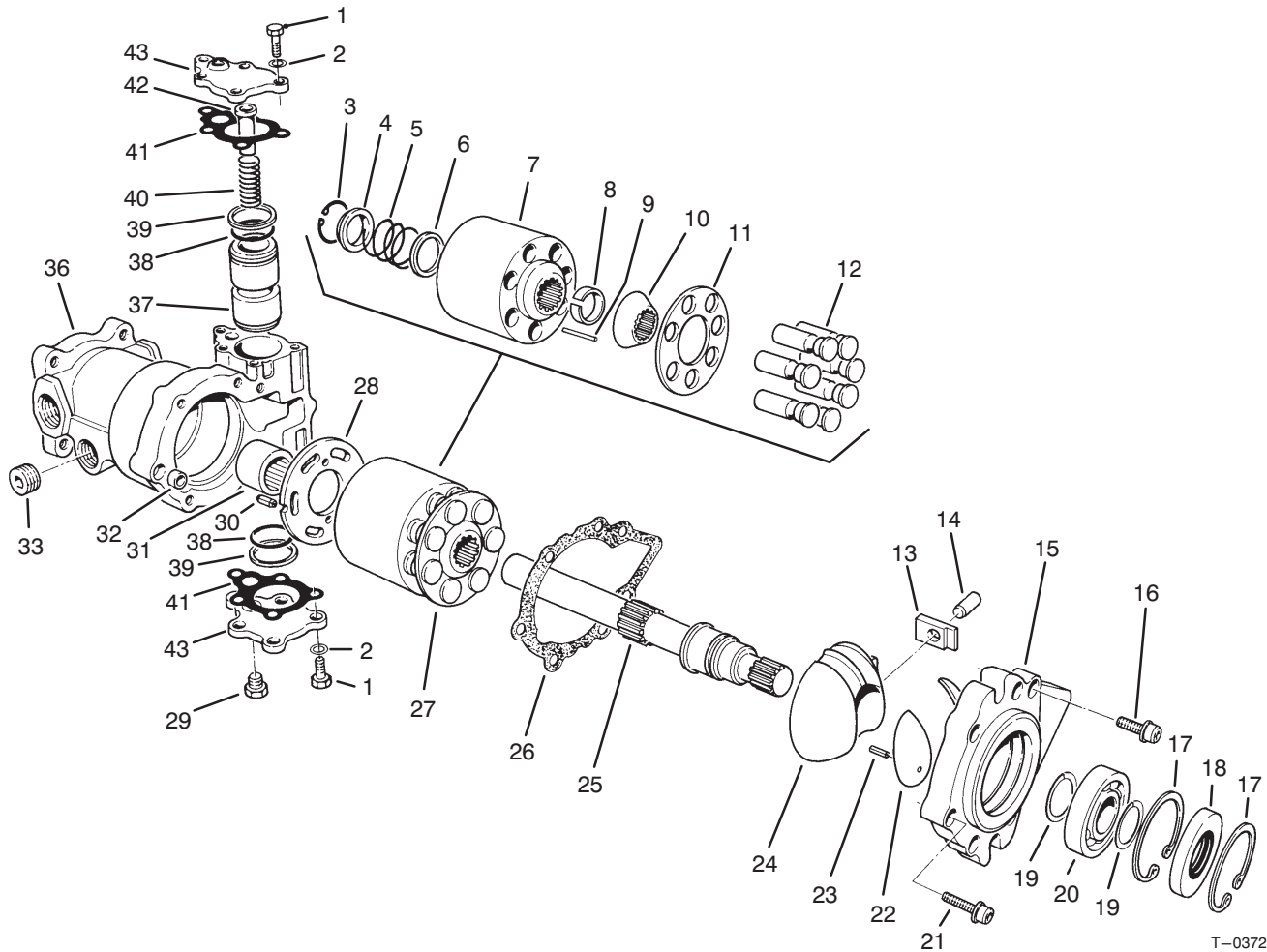

T-0372

WHEEL MOTOR NO. 69-3050

Ref. No.	Part No.	Description	No. Used
1	69-3150	Screw Hex. Hd.	10
2	69-3070	Washer - Plain	10
†3		Ring - Retaining	1
†4		Washer	1
†5		Spring - Compression	1
†6		Washer	1
†7		Block - Cylinder	1
†8		Retainer	1
†9		Pin - Slipper Hold Down	3
†10		Guide - Retainer	1
†11		Guide - Slipper	1
†12		Piston Assembly	7
13	69-3500	Bearing - Sleeve	1
14	69-3510	Pin	1
15	76-4610	Cover - Front	1
16	76-4590	Screw	6
17	69-3200	Ring - Retaining	2
18	69-3190	Seal - Lip	1
19	69-3170	Ring - Retaining	2
20	69-3210	Bearing - Ball	1
21	69-3960	Screw	1
22	69-3970	Bearing - Journal	2

Ref. No.	Part No.	Description	No. Used
23	69-3520	Pin - Spring	2
24	69-3980	Swashplate - Variable	1
25	69-3950	Shaft - Motor	1
26	76-4600	Gasket - Front Cover	1
27	69-3910	Cylinder Block Kit (Incl. Ref. #3-12)	1
28	69-3990	Plate - Motor Valve	1
29	69-3940	Plug	1
30	69-3450	Pin	1
31	69-3370	Bearing - Needle	1
32	69-3230	Pin - Spring	1
33	69-3130	Plug - Hole	1
†36		Housing	1
37	69-4020	Piston - Servo	1
38	69-3560	Seal - O-Ring	2
39	69-3570	Ring - Piston	2
40	69-4030	Spring - Servo	1
41	69-3710	Gasket - Servo Cover	2
42	69-4040	Stop - Servo Piston	1
43	69-3720	Cover - Servo	2
*	69-3920	Piston Ring & O-Ring Kit (Incl. Ref. #38 & 39)	1

*Not Illustrated

†Not serviceable separately.

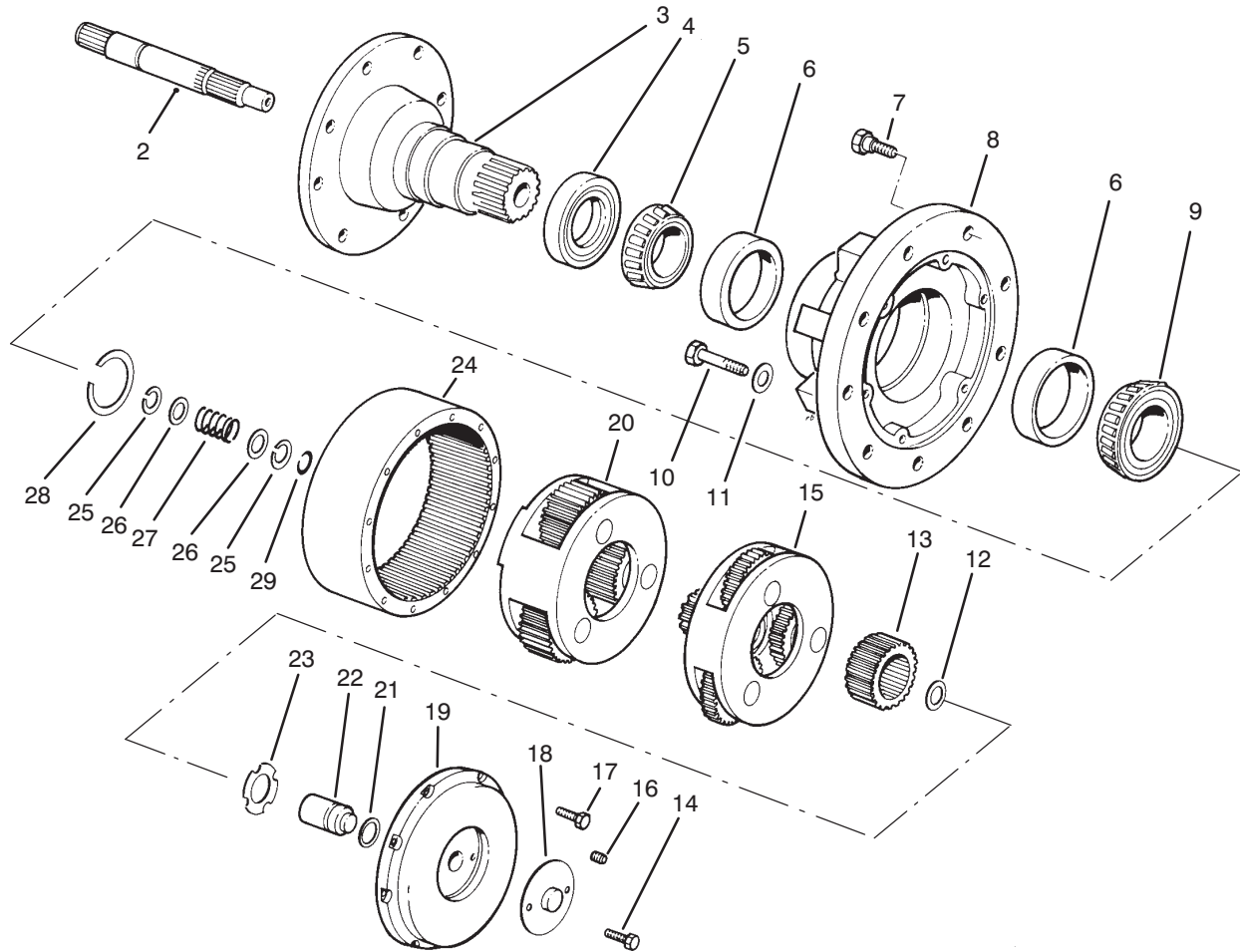

T-0140

PLANETARY GEAR ASSEMBLY NO. 69-1730

Ref. No.	Part No.	Description	No. Used	Ref. No.	Part No.	Description	No. Used
2	60-3810	Shaft - Input	1	16	60-4040	Plug - Pipe	1
3	69-1740	Spindle	1	17	60-4030	Bolt - Hex. Hd.	8
4	60-3830	Seal - Oil	1	18	60-4060	Cover - Disengage	1
5	60-3840	Cone - Bearing	1	19	60-4050	Cover - Large	1
6	60-3850	Cup - Bearing	2	20	60-4000	Secondary Carrier Assy.	1
7	60-3860	Bolt - Wheel	9	21	60-4020	Seal - O-Ring	1
8	60-3870	Hub	1	22	60-4010	Plunger - Disengage	1
9	60-3880	Cone - Bearing	1	23	60-3990	Washer - Thrust	1
10	60-3890	Bolt - Hex. Hd.	6	24	60-3900	Gear - Ring	1
11	60-3910	Washer - Flat	6	25	60-3930	Ring - Retaining	2
12	60-3980	Washer - Thrust	1	26	60-3940	Washer	2
13	60-3970	Gear - Primary Sun	1	27	60-3950	Spring - Disengage	1
14	60-4070	Bolt - Hex. Hd.	2	†28	62-6450	Kit - Retaining Ring	1
15	60-3960	Primary Carrier Assembly	1	*	62-6460	Sealant - RTV (Tube)	1

*Not Illustrated

†Includes 7 different thickness retaining rings for service adjustment of bearings.

WHEEL BRAKE ASSEMBLY

Ref. No.	Part No.	Description	No. Used
2	32151-100	Ring - Retaining	2
3	69-8910	Washer	2
4	82-7850	Spring - Compression	2
5	354-104	Ring - Backup	2
6	237-175	O-Ring	2
7	82-7840	Piston - Brake	2
8	21-2070	Yoke - End	2
9	237-174	O-Ring	2
10	354-105	Ring - Backup	2
11	82-7830	Screw - Bleed, Brake	2
12	92-8003	Housing - Actuator, R.H.	1
*	92-8004	Housing - Actuator, L.H.	1
13	82-7820	Seat - Brake, Tube	2
14	71-3870	Gasket	2
15	71-3850	Cover - Housing	2
16	3253-3	Washer - Lock	8
17	321-2	Screw - Cap Hex. Hd.	8
18	3274-7	Screw - Cap Socket Hd.	8
19	3253-21	Washer - Lock	8

Ref. No.	Part No.	Description	No. Used
20	32128-25	Nut - Lock	2
21	71-3830	Bellcrank - Brake	2
22	3272-6	Pin - Cotter	2
23	71-3880	Clevis - Brake Cable	2
24	283-2	Pin - Clevis	2
25	71-3900	Gasket	2
26	3272-10	Pin - Cotter	2
27	3256-24	Washer - Flat	4
28	71-3860	Clevis	2
29	3296-3	Nut - Lock	2
30	69-0030	Spring - Compression	2
31	283-15	Pin - Clevis	2
32	12-8900	Bolt - Shoulder	2
33	93-7417	Gasket	2
34	71-3910	Collar	2
35	3296-59	Nut - Lock	2
36	93-7418	Cap - Actuator	2
37	321-6	Screw - Cap Hex. Hd.	8

*Not Illustrated

VARIABLE DISPLACEMENT PUMP INSTALLATION

Ref. No.	Part No.	Description	No. Used
1	93-9322	Variable Displacement Pump	1
2	32128-21	Nut - Flange Lock	2
3	93-7189	Yoke - Pump End	1
4	93-7191	Tube - Slip Yoke	1
5	302-2	Fitting - Grease	1
6	93-7188	Shaft - Slip Yoke	1
7	93-7190	Kit - Universal Joint	2
8	93-7187	Yoke - Engine End	1
9	48-9570	Washer - Lock	8
10	48-7710	Screw - Cap Hex. Hd.	8
11	3274-20	Screw - Hex. Socket Hd.	2
12	325-7	Screw - Cap Hex. Hd.	2
13	3253-7	Washer - Lock	2
14	3217-9	Nut - Hex.	2
15	237-81	Seal - O-Ring	1
16	340-131	Fitting - Hydraulic Elbow (Incl. Ref. #15 & 17)	1
17	237-30	Seal - O-Ring	2
18	69-5460	Hose - Hydraulic	1
19	237-146	Seal - O-Ring	3
20	340-15	Fitting - Hydraulic Elbow (Incl. Ref. #19 & 21)	3
21	237-58	Seal - O-Ring	3
22	69-5650	Hose - Hydraulic	1
23	237-42	Seal - O-Ring	1
26	69-9020	Nut - Special	1
27	32152-4	Nut - Lock	2

Ref. No.	Part No.	Description	No. Used
28	69-9480	Bracket - Neutral Device	1
29	3219-2	Nut - Hex.	1
30	32144-1	Screw - Hex. Hd.	2
31	69-9040	Cam - Neutral Device	1
32	3253-21	Washer - Lock	3
33	3231-30	Bolt - Carriage	1
34	3217-7	Nut - Hex.	1
35	93-9337	Bracket - Switch	1
36	3234-13	Screw - Hex. Flange Hd.	4
37	32127-11	Nut - Flexlok	2
38	29-6170	Leaf Spring Assembly	1
39	322-17	Screw - Cap Hex. Hd.	1
40	3210-7	Screw - Cap Hex. Hd.	1
41	251-259	Bearing - Neutral Detent	1
42	321-4	Screw - Cap Hex. Hd.	2
43	29-6150	Spring - Leaf	1
44	32153-3	Nut - Lock	1
45	69-9050	Bar - Neutral Device	1
46	3253-3	Washer - Lock	2
47	321-10	Screw - Cap Hex. Hd.	2
48	340-134	Fitting - Hydraulic Elbow (Incl. Ref. #23)	1
49	41-8760	Gasket - Pump	1
50	93-7424	Hose - Hydraulic	1
51	323-7	Screw - Cap Hex. Hd	2
52	69-2220	Pump/Valve	1
53	327-80	Seal - O-Ring	2

VARIABLE DISPLACEMENT PUMP INSTALLATION (Cont.)

Ref. No.	Part No.	Description	No. Used
54	340-130	Fitting - Hydraulic Elbow (Incl. Ref. #25 & 53)	1
55	340-105	Fitting - Hydraulic Elbow (Incl. Ref. #17 & 53)	1
56	69-5450	Hose - Hydraulic	1
57	69-5470	Hose - Hydraulic	1

Ref. No.	Part No.	Description	No. Used
58	69-5440	Hose - Hydraulic	1
59	69-5480	Hose - Hydraulic	1
60	51-3150	Shim - Spring	A/R
61	93-7037	Switch	1
*	93-3219	Pump Drive Shaft Assembly (Incl. Ref. #3-8)	1

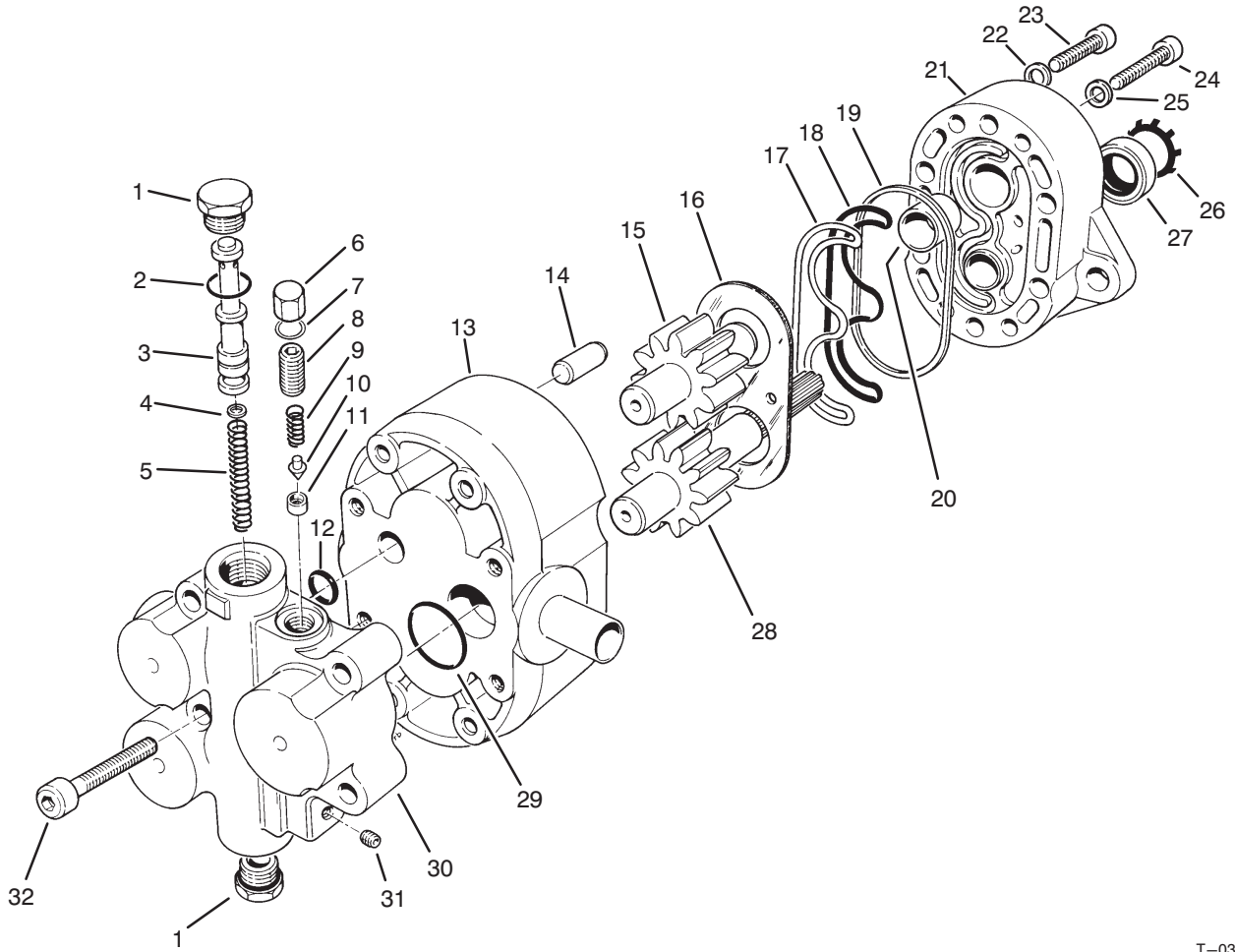

T-0374

GEAR PUMP & FLOW DIVIDER NO. 69-2220

Ref. No.	Part No.	Description	No. Used
1	69-2410	Plug (Incl. Ref. #2)	2
2	69-2420	Seal - O-Ring	2
3	69-2450	Piston	1
4	69-2440	Orifice	1
5	69-2430	Spring - Compression	1
6	69-2460	Cap	1
7	69-2470	Gasket - Cap	1
8	69-2480	Screw - Set	1
9	69-2490	Spring - Compression	1
10	69-2500	Poppet	1
11	69-2510	Seat	1
12	69-2530	Seal - O-Ring	1
13	69-2540	Cover Assembly (Incl. Ref. #20)	1
14	69-2340	Pin - Dowel	2
15	69-2280	Shaft/Gear - Idler	1
16	69-2320	Plate - Wear	1
17	69-2260	Seal - Load	1
18	69-2270	Seal - Pre-Load	1
19	69-2350	Ring - Sealing	1

Ref. No.	Part No.	Description	No. Used
20	69-2250	Bearing - Sleeve	4
21	69-2330	Body Assembly (Incl. Ref. #20)	1
22	69-2370	Washer	4
23	69-2360	Screw	4
24	69-2380	Screw	4
25	69-2390	Washer	4
26	69-2300	Ring - Retaining	1
27	69-2310	Seal - Shaft	1
28	69-2290	Shaft/Gear - Drive	1
29	69-2400	Seal - O-Ring	1
30	69-2230	Flow Divider Assembly (Incl. Ref. #1-11 & 31)	1
31	69-2520	Plug - Pipe	1
32	69-2240	Screw	4
*	69-2550	Repair Kit - Pump (Incl. Ref. #16-19, 22 & 25-27)	1
*	69-2560	Repair Kit - Pump & Divider Incl. Ref. #2, 7, 9-10, 12, 16-19, 22, 25-27 & 29)	1

*Not Illustrated

VARIABLE DISPLACEMENT PUMP NO. 93-9322

Ref. No.	Part No.	Description	No. Used
1	69-3620	Cover - Servo Adjustment	1
2	69-3630	Nut Special	1
3	69-3640	Cover - Servo	1
4	69-3710	Gasket - Servo	2
5	69-3610	Nut - Jam	1
6	69-3600	Nut - Hex.	1
7	69-3590	Ring - Retaining	1
8	69-3580	Guide - Spring	1
9	69-3130	Plug (Incl. Ref. #10)	1
†10		Seal - O-Ring	1
†11		Housing - Pump	1
12	69-3230	Pin - Spring	1
13	69-3370	Bearing - Needle	1
†14		Ring - Retaining	1
†15		Washer	1
†16		Spring - Compression	1
†17		Washer	1
†18		Block - Cylinder	1
†19		Retainer	1
†20		Pin - Slipper Hold Down	3
†21		Guide - Retainer	1
†22		Guide - Slipper	1
†23		Piston - Assembly	7
24	69-3250	Swashplate - Variable	1
25	69-3240	Bearing - Journal	2
26	69-3520	Pin	2
27	76-4590	Screw	6

Ref. No.	Part No.	Description	No. Used
28	69-3220	Screw	1
29	69-3200	Ring - Retaining	2
30	69-3190	Seal - Lip	1
31	69-3170	Ring - Retaining	2
32	69-3210	Bearing - Ball	1
33	76-4610	Cover	1
34	69-3500	Sleeve - Bearing	1
35	69-3510	Pin	1
36	69-3470	Pin	1
37	69-3180	Shaft Pump	1
38	76-4600	Gasket - Cover	1
39	69-3910	Cylinder Block Assembly (Incl. Ref #14-23)	1
40	93-9320	Plate - Valve L.H.	1
41	69-3450	Pin	1
42	69-3820	Sleeve - Control Valve	1
43	28-3590	Seal O-Ring	1
44	28-3580	Ring - Back Up	1
45	69-3880	Spring - Neutral Return	1
46	69-3830	Spool - Rotary Valve	1
47	25-2630	Ring Back Up	1
48	69-3890	Bracket - Neutral Return	1
49	69-3860	Screw - Flange Hd.	1
50	69-3870	Handle - Control Valve	1
51	69-3900	Washer	1
52	69-3840	Seal - O-Ring	1
53	69-3650	Piston - Servo	1

†Not serviceable separately.

VARIABLE DISPLACEMENT PUMP NO. 93-9322 (Cont.)

Ref. No.	Part No.	Description	No. Used
54	69-3690	Bearing	2
55	69-3560	Seal - O-Ring	2
56	69-3570	Ring - Piston	2
57	69-3720	Cover Servo	1
58	69-3140	Bracket - Lifting	1
†59		Seal - O-Ring	6
60	69-3080	Plug (Incl. Ref. #59)	6
61	69-3150	Screw - Hex. Hd.	10
62	69-3070	Washer - Lock	10
63	25-2630	Ring - Back Up	1
64	237-22	Seal - O-Ring	1
65	69-3800	Valve	1
66	69-3810	Valve - By Pass	1
67	69-3780	Plug (Incl. Ref. #68)	1
68	237-80	Seal - O-Ring	1
69	69-3770	Shim	1
70	69-3790	Spring Compression	1
71	69-3760	Plug Special (Incl. Ref. #77)	2
72	69-3740	Spring - Compression	2
73	69-3110	Screw	2
74	69-3160	Seal - O-Ring	3
75	93-9321	Plug - Orifice	1

Ref. No.	Part No.	Description	No. Used
76	285-17	Plug - Pipe	2
77	69-3750	Seal - O-Ring	2
78	69-3730	Valve - Relief (Incl. Ref. #71, 72 & 77)	2
79	69-3090	Adapter - Suction	1
80	69-3460	Plug Expansion	1
81	69-3550	Pin	1
82	69-3100	Screw	1
83	69-3400	Screw Hex. Hd.	3
84	69-3430	Key - Woodruff	1
85	69-3410	Adapter - A Flange	1
86	69-3420	Ring - Temper Load	1
87	69-3440	Seal - O-Ring	1
88	69-3540	Cover - Gerotor	1
89	69-3390	Gerotor Assembly	1
90	69-3700	Guide - Spring	1
91	69-3660	Screw - Special	1
92	69-3680	Stop - Servo	1
93	69-3670	Spring - Compression	1
†94		Seal O-Ring	1
95	69-3120	Plug (Incl. Ref. #94)	1

†Not serviceable separately.

COWL ASSEMBLY

Ref. No.	Part No.	Description	No. Used	Ref. No.	Part No.	Description	No. Used
1	58-4250	Magnet	6	18	69-9721	Strip - Sealing	3
2	32149-2	Nut - Keps	16	19	75-9460	Bracket - Sealing L.H.	1
3	71-0280	Foam - Cowl Top	1	20	69-0040	Foam - Lower Grille	1
4	321-2	Screw - Cap Hex. Hd.	16	21	32144-11	Screw - Hex. Flange Hd.	8
5	71-0240	Foam - Louver Top	2	22	75-9480	Bracket - Sealing Bottom	1
6	69-9370	Louver - Top	2	23	69-7150	Grille - Lower	1
7	71-0230	Foam - Louver Middle	1	24	32153-6	Nut Lock	2
8	69-1130	Louver - Middle	1	25	75-9470	Bracket - Sealing R.H.	1
9	69-9650	Screen - Cowl	2	26	328-11	Screw - Cap Hex. Hd.	2
10	69-8650	Cowl - Radiator	1	27	69-7120	Grille - Upper	1
*	82-6330	Cowl - Radiator, Optional	1	28	69-9720	Strip - Sealing	2
11	71-0220	Foam - Louver Lower	1	29	71-0290	Foam - Cowl Bottom	1
12	3296-2	Nut - Flange Lock	20	30	71-0330	Foam - Low Rear Cowl L.H.	1
13	69-3030	Strike - Latch	8	*	71-0320	Foam - Low Rear Cowl R.H.	1
14	3290-321	Screw - Hex. Washer Hd.	20	31	69-1140	Louver - Lower	1
15	69-8690	Support - Grille	1	32	3269-15	Rivet - Pop	22
16	69-3020	Handle - Latch	2	33	3269-6	Washer - Backup	22
17	71-0300	Foam - Low Front Cowl L.H.	1	34	250-5	Tie - Cable	16
*	71-0310	Foam - Low Front Cowl R.H.	1	35	69-9722	Trim - Sealing	1

*Not Illustrated

HOOD ASSEMBLY

Ref. No.	Part No.	Description	No. Used	Ref. No.	Part No.	Description	No. Used
1	71-0270	Foam - Hood Side R.H.	1	15	69-9723	Seal - Hood Bottom	2
2	71-0250	Foam - Hood Top	1	16	32149-2	Nut - Keps	16
3	71-0260	Foam - Hood Side L.H.	1	17	69-8230	Bracket - Trim L.H.	1
4	92-1772	Hood Assembly (Incl. Ref.#1-4, 8, 15-17, 20, 26 & 29)	1	18	88-6770	Stud - Ball	2
5	3290-321	Screw - Cap Hex. Hd.	12	19	88-6760	Spring - Gas	2
6	69-3010	Strap - Hold Down (Incl. Ref. #10)	4	20	69-8250	Bracket - Trim R.H.	1
7	3296-2	Nut - Flange Lock	12	21	69-8500	Shim - Hinge Bracket	6
8	71-0060	Support - Foam	1	22	3253-21	Washer - Lock	6
9	69-9520	Panel - Rear	1	23	323-6	Screw - Cap Hex. Hd.	4
†10		Latch - Hold - Down	4	24	3256-24	Washer - Flat	6
11	3234-14	Screw - Cap Hex. Hd.	6	25	323-4	Screw - Cap Hex. Hd.	2
12	69-1390	Panel - Side L.H.	1	26	69-0950	Decal - 580D	2
*	69-1380	Panel - Side R.H.	1	27	66-6140	Decal - TORO	1
13	3290-134	Screw - Cap Hex. Hd.	4	28	69-8520	Bracket - Hinge	2
14	71-0400	Foam - Side Panel	2	29	69-9724	Seal - Hood Front	1
				30	32149-7	Nut	4
				31	32152-1	Nut	2

*Not Illustrated

†Not serviceable separately.

RADIATOR & OIL COOLER ASSEMBLY

Ref. No.	Part No.	Description	No. Used
1	71-0350	Foam - Rad. Support R.H.	1
2	69-8590	Support - Radiator Upper	1
3	71-0360	Foam - Rad. Support Top	1
4	69-5380	Hose - Upper Radiator	1
5	66-3241	Cap - Radiator	1
6	2412-6	Clamp - Hose	1
7	23-2140	Hose - Radiator Vent	1
8	323-34	Screw - Cap Hex. Hd.	7
9	13-4239	Shroud - Fan (Incl. Ref. #45 & 46)	1
10	69-5390	Hose - Lower Radiator	1
11	2412-92	Clamp - Hose	4
12	69-1640	Radiator	1
13	71-0210	Foam - Radiator Seal	1
14	304-46	Valve - Drain	1
15	2812-4	Fitting - Reducer	2
16	340-124	Fitting - Hydraulic Straight (Incl. Ref. #17)	2
17	237-22	Seal - O-Ring	2
18	69-8430	Hose - Hydraulic	2
19	32128-20	Nut - Flange Lock	5
20	69-3020	Latch	8
21	3253-2	Washer - Lock	16
22	3290-321	Screw - Cap Hex. Hd.	16
23	46-3380	Bolt - Shoulder	2
24	69-7100	Support - Radiator Lower	1

Ref. No.	Part No.	Description	No. Used
25	3290-216	Washer - Bevel	4
26	32153-5	Nut - Lock	2
27	32152-2	Nut - Lock	7
28	340-65	Seal - O-Ring	3
29	69-5620	Hose - Hydraulic	1
30	69-8450	Hose - Hydraulic (Incl. Ref. #28)	1
31	69-5900	Tube - Hydraulic	1
32	69-1670	Cooler - Oil (Incl. Ref. #28)	1
33	32103-3	Nut - Wing	2
34	71-0370	Foam - Lower Rad. Support	2
35	3253-21	Washer - Lock	12
36	71-0340	Foam - Rad. Support L.H.	1
37	88-9450	Bracket - Hood Cylinder	2
38	2412-41	Clamp - R	1
39	322-5	Screw - Cap Hex. Hd.	1
40	322-6	Screw - Cap Hex. Hd.	4
41	323-7	Screw - Cap Hex. Hd.	4
42	71-0380	Foam - Rad. Support Front	1
43	325-6	Screw - Cap Hex. Hd.	2
44	71-0390	Foam - Rad. Support Rear	1
45	76-8750	Plate - Caution	2
46	3290-271	Rivet - Pop	4
47	3256-56	Washer - Flat	2
48	2412-147	Clamp - R	1
50	68-6150	Breather	1

T-0359A

RADIATOR & OIL COOLER ASSEMBLY (Continued)

Ref. No.	Part No.	Description	No. Used
51	354-95	Fitting	1
52	2412-108	Clamp - Hose	2
53	71-2680	Hose - Vent	1

Ref. No.	Part No.	Description	No. Used
54	32144-69	Screw - Cap, Hex. Hd.	6
56	88-6770	Stud - Ball	2
57	32152-1	Nut - Lock	2

ENGINE INSTALLATION ASSEMBLY

Ref. No.	Part No.	Description	No. Used
1	3219-14	Nut - Hex.	2
2	48-8070	Washer - Lock	16
3	2412-70	Clamp - R	1
4	67-4510	Sending Unit - Temperature	1
5	39-7592	Switch - Temperature	1
6	48-7930	Nut - Lock	3
7	48-9570	Washer - Lock	3
9	69-6250	Engine - Assembly	1
10	76-0980	Pipe - Exhaust	1
11	69-9420	Muffler	1
12	20-4840	Clamp - Exhaust	2
13	69-5350	Hose - Air Cleaner Inlet	1
14	3258-19	Screw - Machine	2
15	69-1890	Air Cleaner Assembly	1
16	2412-110	Clamp - Hose	3
17	69-5360	Hose - Air Cleaner	1
18	93-4382	Bracket - Muffler	1
19	2412-42	Clamp - Hose	1
20	3234-14	Screw - Hex. Washer Hd.	4
21	48-9480	Screw - Cap Hex. Hd.	4
22	48-9590	Washer - Lock	22
23	17-7190	Spacer	4
24	58-3590	Pin - Flywheel	2
25	48-9470	Screw - Cap Hex. Hd.	8
26	92-1753	Coupling - Spring Centering	1
27	32107-11	Nut - Square	2
28	69-1950	Band - Air Cleaner (Incl. Ref. #14 & 27)	2

Ref. No.	Part No.	Description	No. Used
29	69-9530	Bracket - Air Cleaner	1
30	32128-20	Nut - Flange Lock	4
31	69-9550	Plate - Adapter	1
32	48-7780	Screw - Cap Hex. Hd.	6
33	32149-2	Nut - Keps	5
34	69-8410	Screw - Cap Hex. Hd.	4
35	69-8420	Washer - Lock	4
36	69-8490	Bracket - Throttle Cable	1
37	85-6210	Bracket - Rear Eng. Mount	2
38	321-6	Screw - Cap Hex. Hd.	3
39	69-0060	Screw - Cap Hex. Hd.	16
40	69-1660	Mount - Engine	4
41	32153-5	Nut - Lock	8
42	69-7580	Bracket - Front Engine Mount L.H.	1
*	69-7570	Bracket - Front Engine Mount R. H.	1
43	325-17	Screw - Cap Hex. Hd.	4
44	69-1750	Fuel Filter Assembly	1
45	85-6230	Solenoid - Engine Run	1
46	325-4	Screw - Cap Hex. Hd.	4
47	3272-6	Pin - Cotter	1
48	3256-1	Washer - Flat	1
49	69-9110	Rod - Engine Run Solenoid	1
50	3220-1	Nut - Jam	2
51	321-4	Screw - Cap Hex. Hd.	2
52	2411-41	End - Rod	2
53	69-9360	Bracket - Fuel Filter	1

*Not Illustrated

ENGINE INSTALLATION ASSEMBLY (Continued)

Ref. No.	Part No.	Description	No. Used
54	3256-26	Washer - Flat	8
55	69-8460	Fitting - Hydraulic Straight (Incl. Ref. #56)	2
56	237-22	Seal - O-Ring	2
57	32152-1	Nut - Lock	2
58	69-9070	Bracket - Clamp	1
59	2412-41	Clamp - R	2
60	323-6	Screw - Cap Hex. Hd.	1
61	71-4280	Sending Unit - Oil Pressure	1
62	69-1680	Fan	1
63	69-9710	Nut - Lock	4
64	69-1690	Clutch - Fan	1
65	3253-2	Washer - Lock	2

Ref. No.	Part No.	Description	No. Used
66	39-7591	Thermo Switch Assembly	1
67	3256-3	Washer - Flat	3
68	2412-39	Clamp - R	1
69	2412-73	Clamp - R	1
70	323-4	Screw - Cap Hex. Hd.	4
71	69-1940	Indicator - Electrical	1
72	48-7630	Screw	1
73	48-7890	Nut - Hex.	1
74	3253-3	Washer - Lock	1
75	3253-21	Washer - Lock	4
76	322-13	Screw - Cap Hex. Hd.	1
77	56-7974	Clamp Half - Hydraulic Line	2
78	69-9761	Plate - Cover	1

*Not Illustrated

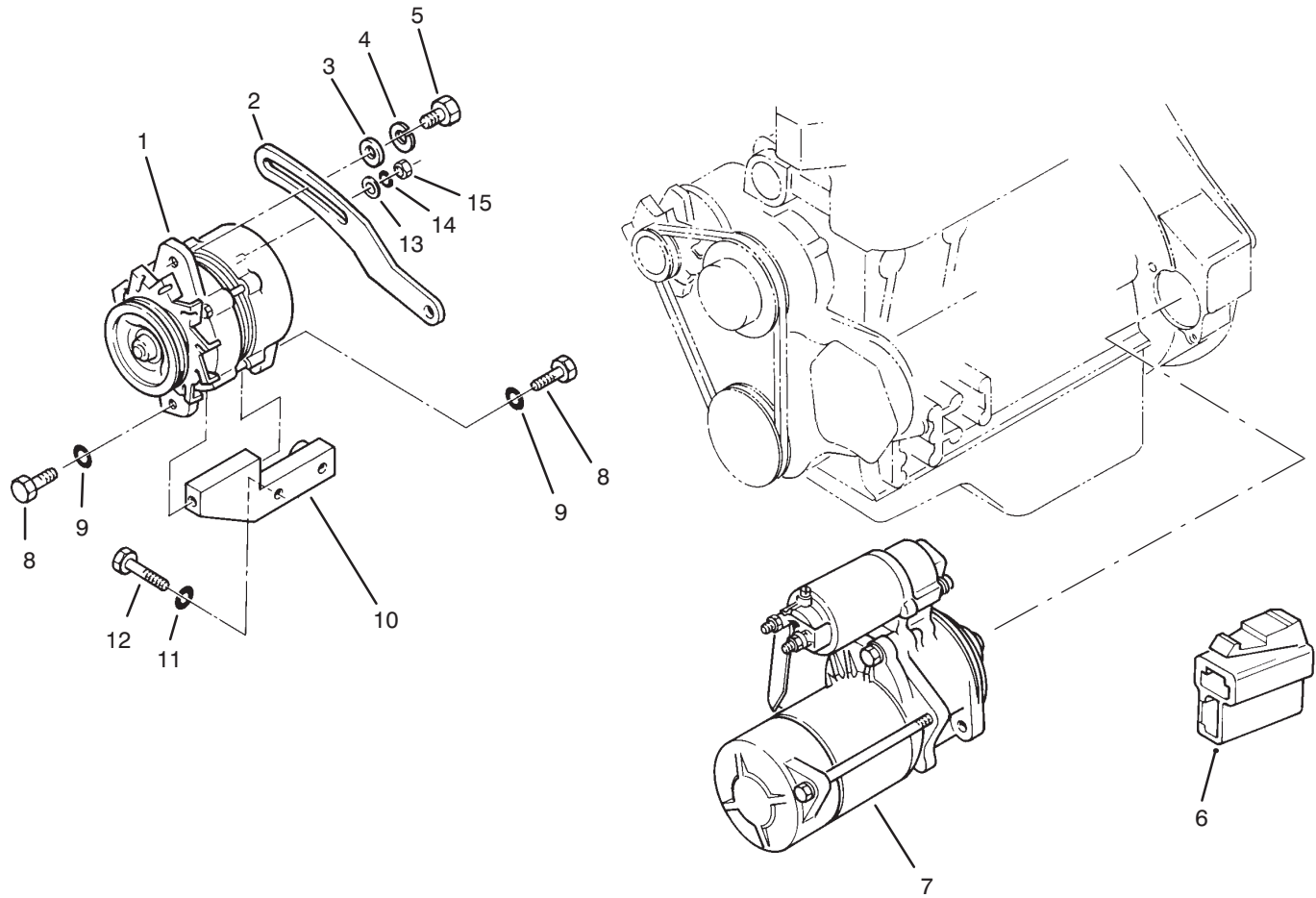

T-0580

STARTER & ALTERNATOR INSTALLATION ASSEMBLY

Ref. No.	Part No.	Description	No. Used
1	70-5760	Alternator Assembly	1
2	70-5740	Plate	1
3	51-8590	Washer	1
4	51-7250	Washer - Lock	1
5	60-7370	Bolt	1
6	59-6910	Connector	1
7	70-5860	Starter Assembly	1
8	51-8640	Bolt	2

Ref. No.	Part No.	Description	No. Used
9	51-6390	Washer - Lock	2
10	70-5750	Bracket	1
11	51-8610	Washer - Lock	2
12	70-2940	Bolt	2
13	5-3637	Washer - Flat	1
14	43-5920	Washer - Lock	1
15	43-5970	Nut - Hex.	1

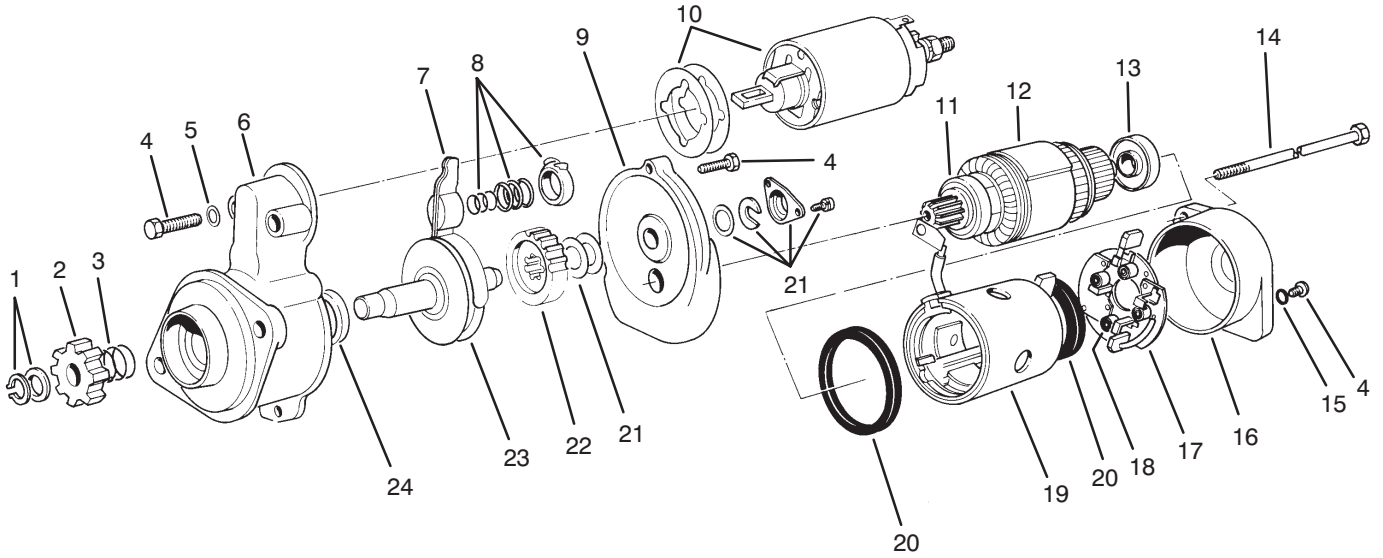

T-0160

STARTER MOTOR ASSEMBLY NO. 70-5860

Ref. No.	Part No.	Description	No. Used
1	51-7740	Retaining Ring Assembly	1
2	51-7730	Gear Pinion Assembly (Incl. Ref. #1 & 3)	1
†3		Spring	1
4	51-7600	Screw Set	1
5	51-7610	Packing	2
6	70-3280	Cover Assembly Front (Incl. Ref. #24)	1
7	51-7640	Lever Assembly	1
8	51-7650	Spring Assembly	1
9	51-7660	Bracket Assembly Center	1
10	51-7670	Solenoid	1
11	51-7690	Bearing	1
12	70-3260	Armature Assembly (Incl. Ref. #11 & 13)	1
13	70-3330	Bearing	1

Ref. No.	Part No.	Description	No. Used
14	70-3310	Bolt Set	1
15	51-7840	Ring - Rubber	2
16	51-7830	Cover - Rear	1
17	70-3290	Brush Holder Assembly (Incl. Ref. #18)	1
18	70-3270	Spring - Brush	4
19	70-3300	Yoke Assembly	1
20	51-7790	Packing	2
21	51-7780	Cover Assembly	1
22	51-7770	Gear - Pinion	1
23	51-7760	Shaft Assembly	1
24	51-7630	Seal - Oil	1
*	51-7750	Gear Assembly (Incl. Ref. #22 & 23)	1
*	51-7720	Clutch Assy. (Incl. Ref. #1-3 & 21-24)	1

*Not Illustrated

†Not Serviceable Separately

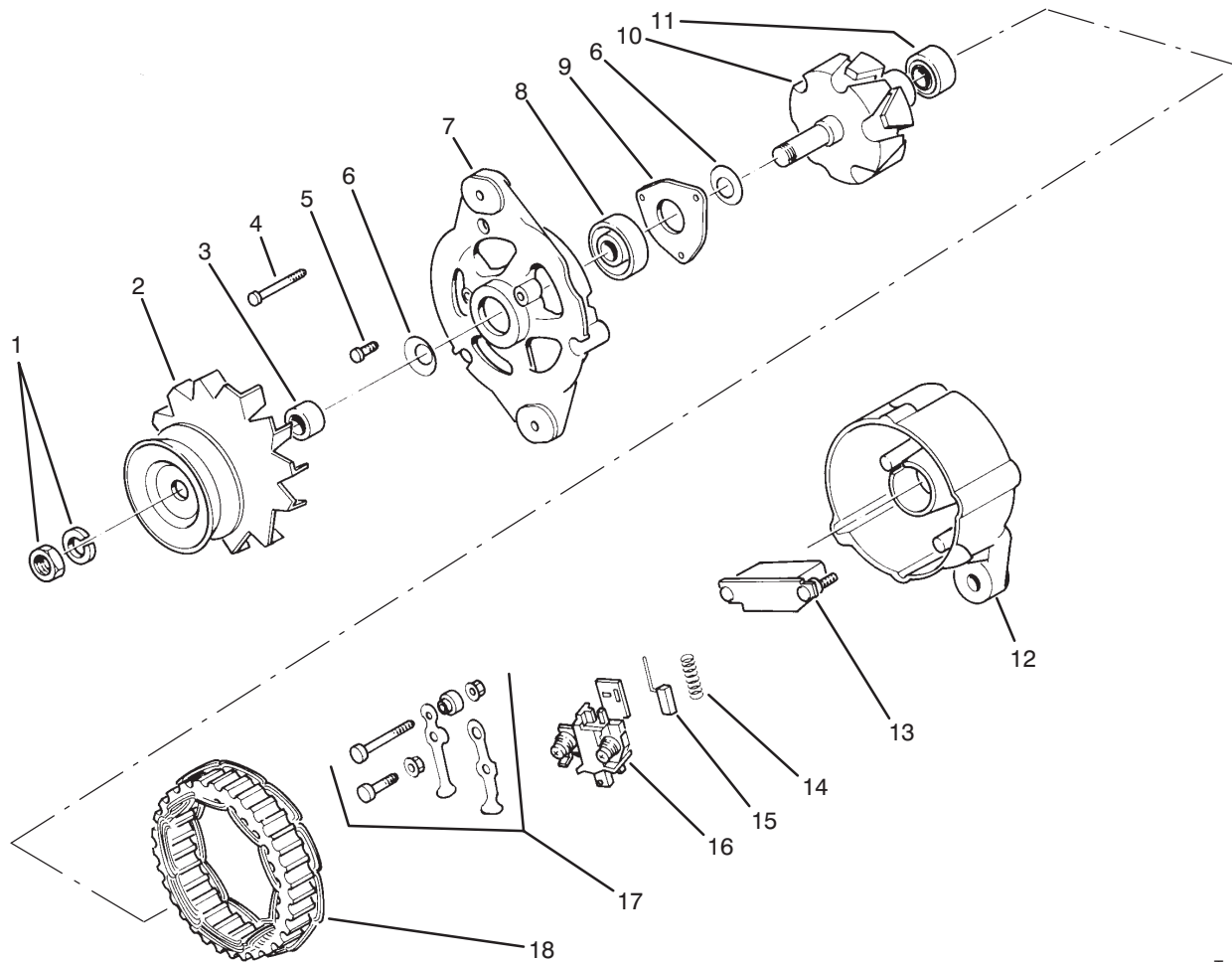

T-0161

ALTERNATOR ASSEMBLY NO. 70-5760

Ref. No.	Part No.	Description	No. Used	Ref. No.	Part No.	Description	No. Used
1	51-7850	Nut Assembly	1	10	51-7910	Rotor Assembly (Incl. Ref. #11)	1
2	70-2800	Pulley Assembly (Incl. Ref. #3)	1	11	60-5360	Bearing	1
†3		Collar - Shaft	1	12	60-5380	Cover Assembly - Rear (Incl. Ref. #13-17)	1
4	51-7870	Screw Set	1	13	60-5370	Rectifier Assembly	1
5	51-7890	Screw Set	1	14	70-2810	Spring - Return	2
†6		Spring Washer	2	15	51-7970	Brush	2
7	60-5340	Cover Assembly - Front (Incl. Ref. #5, 6, 8 & 9)	1	16	51-7960	Regulator Assembly (Incl. Ref. #14 & 15)	1
8	70-3320	Bearing	1	17	51-7950	Terminal Assembly	1
†9		Plate - Bearing Retainer	1	18	51-7930	Stator	1

†Not Serviceable Separately

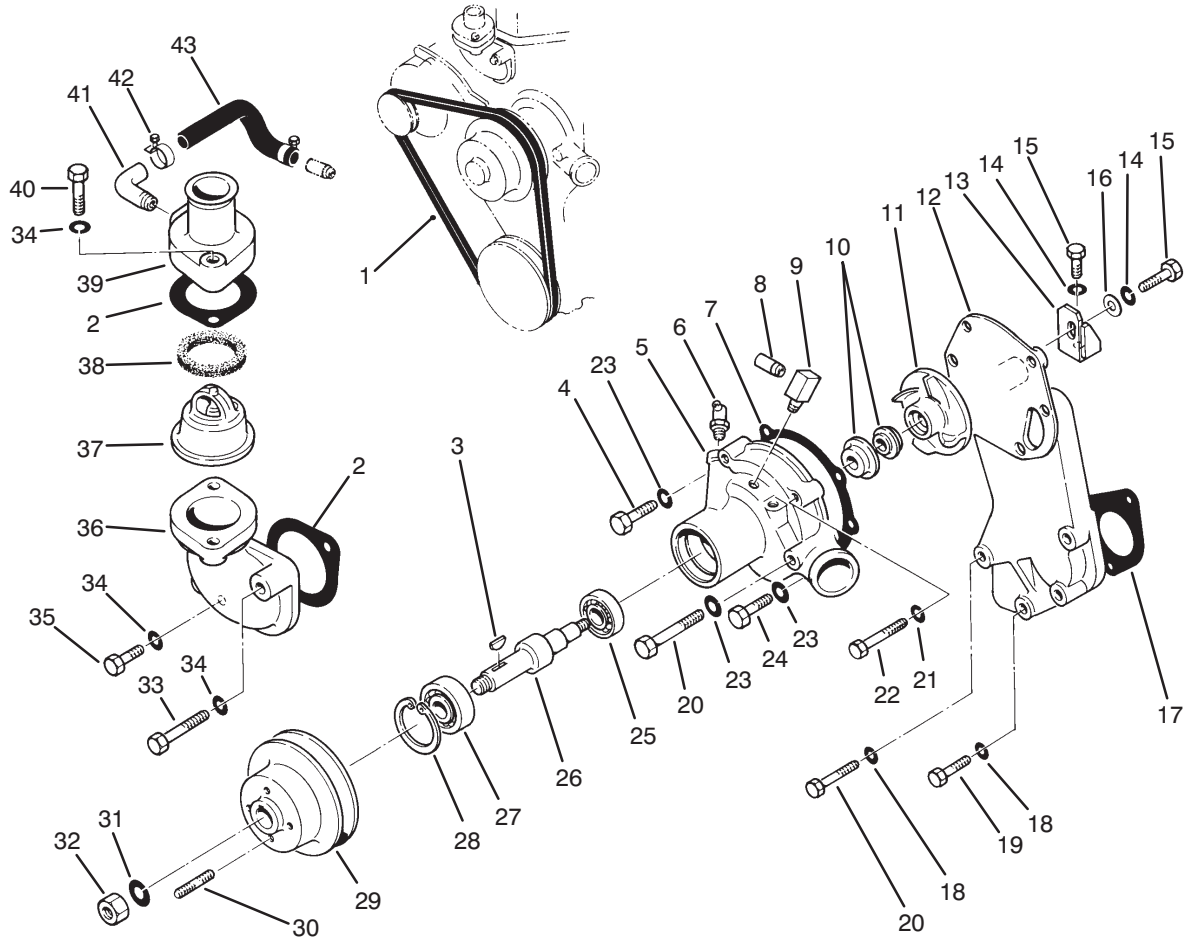

T-0581

WATER PUMP ASSEMBLY

Ref. No.	Part No.	Description	No. Used
1	70-3450	V-Belt	1
†2	51-7210	Gasket	2
3	51-6960	Key	1
4	70-2910	Bolt	1
5	70-5600	Water Pump Assembly (Incl. Ref #3-4, 6-11 & 25-32)	1
6	51-7020	Nipple	1
7	70-5650	Gasket	1
8	51-7170	Pipe	1
9	70-5620	Connector	1
10	51-7030	Seal	1
11	70-5610	Impeller	1
12	70-5640	Bracket	1
13	70-5670	Stay	1
14	51-6390	Washer - Lock	2
15	70-2890	Bolt	2
16	70-2990	Washer	1
†17	70-5660	Gasket	1
18	51-6390	Washer - Lock	4
19	70-2900	Bolt	1
20	70-2920	Bolt	3
21	51-6920	Washer - Lock	2

Ref. No.	Part No.	Description	No. Used
22	70-2850	Bolt	2
23	51-6390	Washer - Lock	4
24	51-4910	Bolt	2
25	51-6980	Bearing	1
26	70-5630	Shaft	1
27	51-6950	Bearing	1
28	51-6940	Ring	1
29	70-5680	Pulley	1
30	70-2950	Stud	4
31	51-6920	Washer - Lock	1
32	51-6910	Nut	1
33	70-2860	Bolt	1
34	51-7250	Washer - Lock	4
35	60-7280	Bolt	1
36	70-5690	Elbow	1
37	51-7230	Thermostat	1
†38	51-7220	Gasket	1
39	70-5050	Cover	1
40	60-7040	Bolt	2
41	70-5590	Connector	1
42	51-7200	Clamp	2
43	70-5040	Hose	1

†Included in Gasket Set No. 70-6950

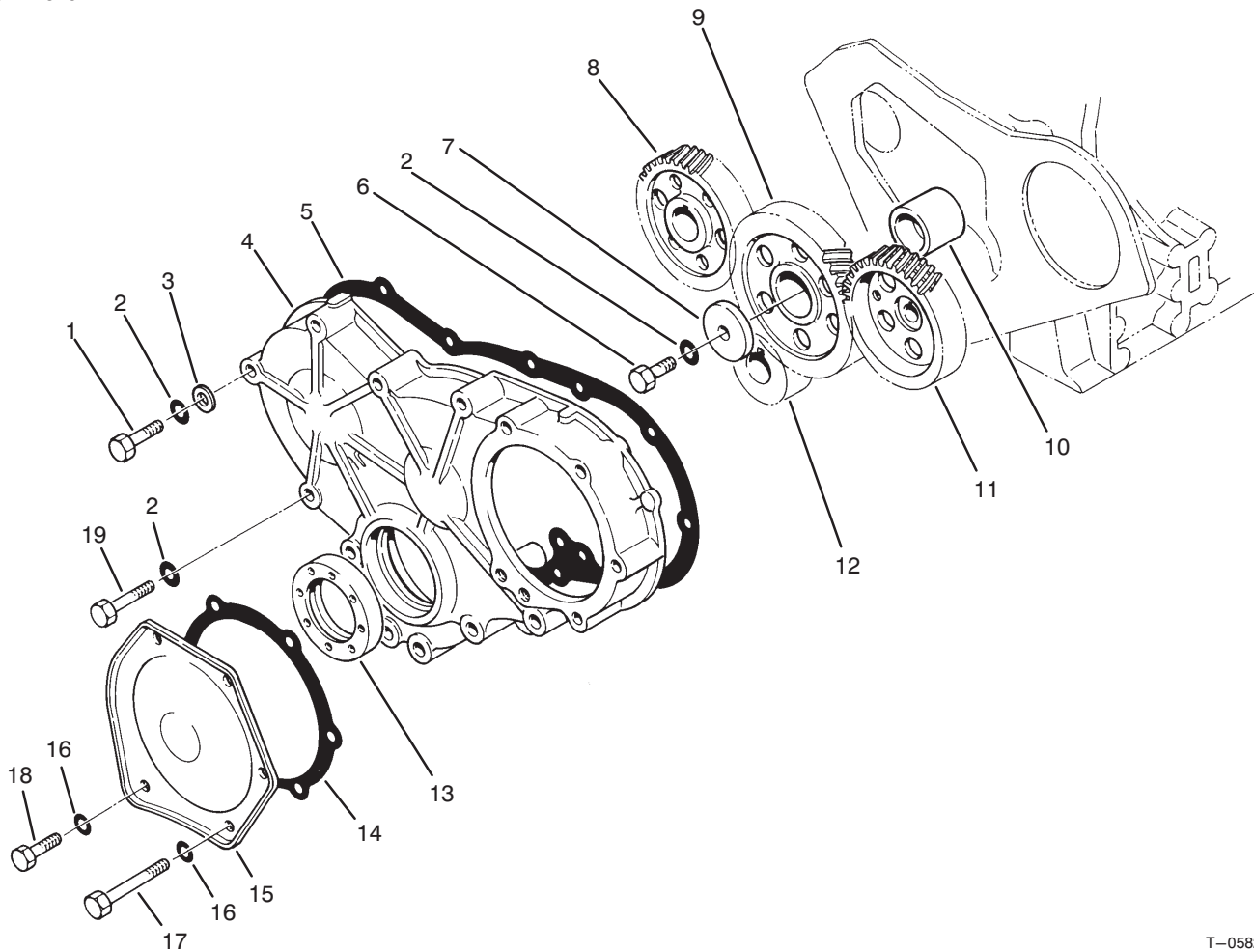

T-0582

TIMING GEAR CASE ASSEMBLY

Ref. No.	Part No.	Description	No. Used
1	51-4920	Bolt	1
2	51-6390	Washer - Lock	11
3	70-2990	Washer	1
4	70-5790	Case	1
†5	70-5370	Gasket	1
6	60-7210	Bolt	1
7	51-6400	Plate	1
8	70-5020	Gear - Camshaft	1
9	70-5450	Idler Assembly (Incl. Ref. #10)	1

Ref. No.	Part No.	Description	No. Used
10	51-6430	Bushing	1
11	70-6040	Gear - Injection Pump	1
12	70-5830	Gear - Crankshaft	1
†13	70-5780	Seal	1
†14	51-5860	Gasket	1
15	51-5850	Cover	1
16	51-7250	Washer - Lock	5
17	70-2860	Bolt	4
18	60-7110	Bolt	1
19	70-2930	Bolt	9

†Included in Gasket Set No. 70-6950

‡Included In Oil Seal Kit No. 70-6960

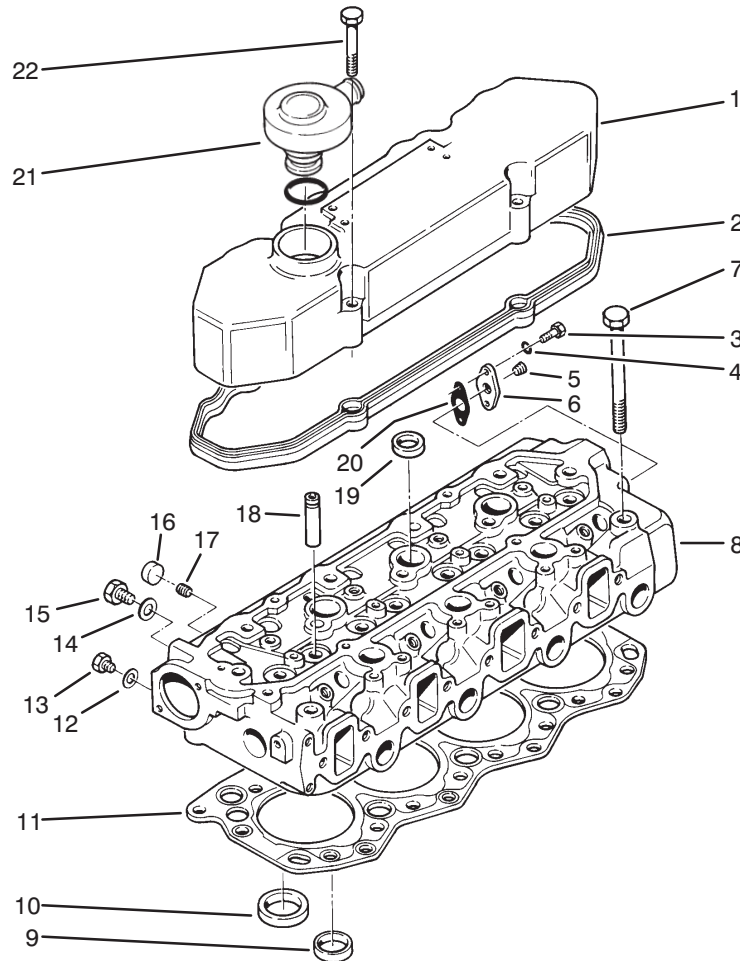

T-0583A

ROCKER COVER & CYLINDER HEAD ASSEMBLY

Ref. No.	Part No.	Description	No. Used	Ref. No.	Part No.	Description	No. Used
1	93-3681	Cover	1	†11	70-5130	Gasket	1
†2	93-3682	Gasket	1	†12	51-5840	Washer	1
3	60-7280	Bolt	2	13	70-3100	Plug	1
4	51-7250	Washer - Lock	2	†14	51-6890	Gasket	1
5	70-5140	Plug	1	15	70-3230	Plug	1
6	70-5890	Flange	1	16	70-3360	Cap	4
7	63-4740	Bolt	17	17	70-3390	Plug	4
8	70-5900	Cylinder Head Assembly (Incl. Ref. #3-6, 9-10 & 12-20)	1	18	51-4950	Guide	8
9	70-5870	Insert - Exhaust	4	19	70-3380	Cap	15
10	70-5880	Insert - Inlet	4	20	70-5090	Gasket	1
				21	70-5570	Breather	1
				22	70-2930	Bolt	4

†Included in Gasket Set No. 70-6950

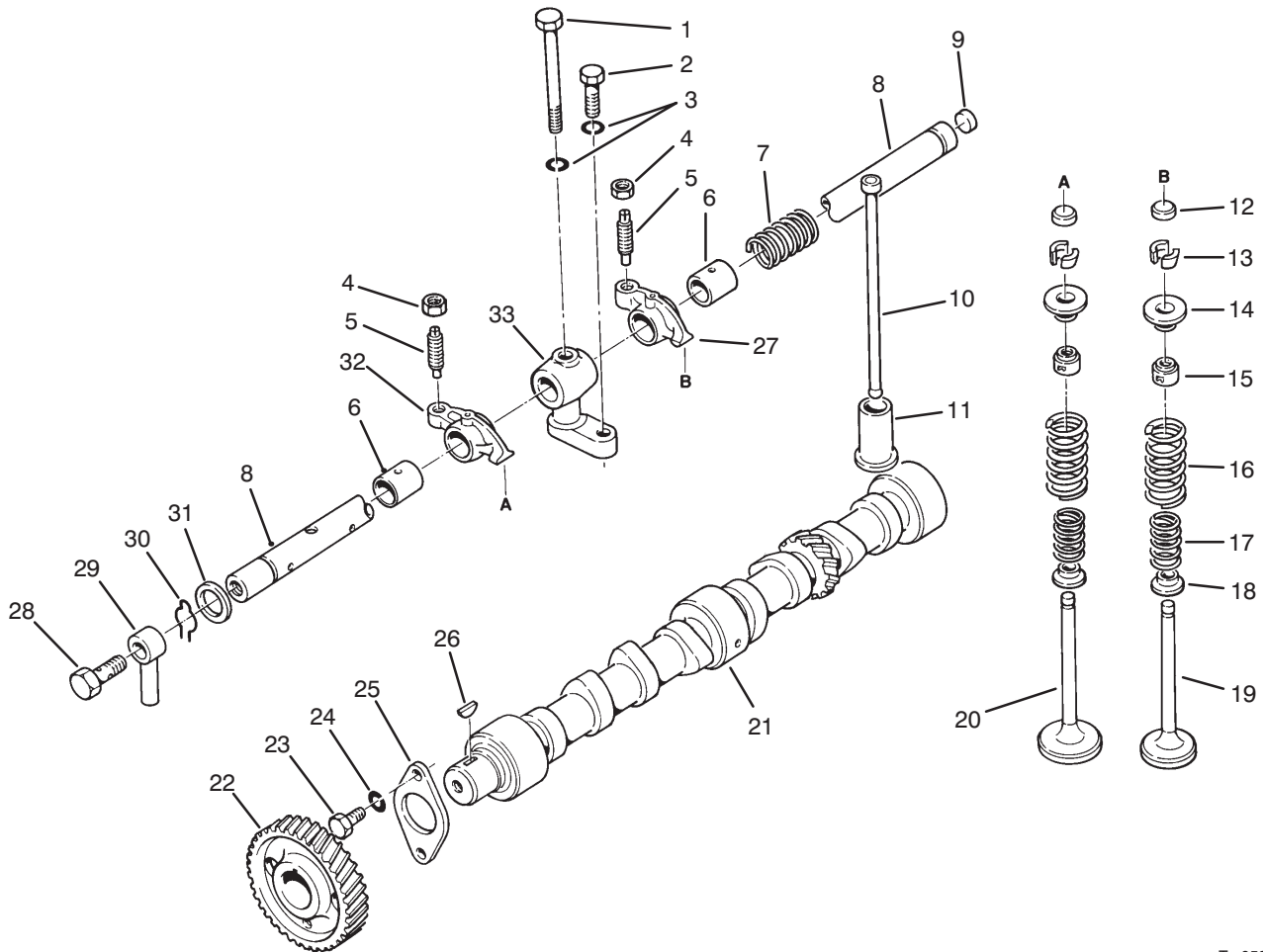

T-0584

VALVE & CAMSHAFT ASSEMBLY

Ref. No.	Part No.	Description	No. Used
1	70-2870	Bolt	4
2	60-7280	Bolt	4
3	51-7250	Washer - Lock	8
4	70-2970	Nut	8
5	70-3160	Screw	8
6	70-5080	Bushing	8
7	70-5190	Spring	3
8	70-5180	Rocker Shaft Assembly (Incl. Ref. #9)	1
9	51-5090	Plug	1
10	70-5230	Rod - Push	8
11	70-5010	Tappet	8
12	51-5280	Cap	8
13	51-5290	Cotter (Available in set w/pair)	16
14	51-5300	Retainer	8
‡15	51-5310	Seal	8
16	70-5930	Spring	8
17	70-4990	Spring	8

Ref. No.	Part No.	Description	No. Used
18	70-5000	Retainer	8
19	70-5920	Valve - Exhaust	4
20	70-5910	Valve - Inlet	4
21	70-5940	Camshaft	1
22	70-5020	Gear - Camshaft	1
23	60-7110	Bolt	2
24	51-7250	Washer - Lock	2
25	51-5470	Plate	1
26	51-5460	Key	1
27	70-5160	Rocker Assembly - Exhaust (Incl. Ref. #4-6)	4
28	70-3050	Bolt	1
29	70-5170	Pipe	1
30	51-5260	Ring - Retaining	2
31	70-5110	Washer	2
32	70-5150	Rocker Assembly - Intake (Incl. Ref. #4-6)	4
33	70-5200	Bracket	4

‡Included in Oil Seal Kit No. 70-6960

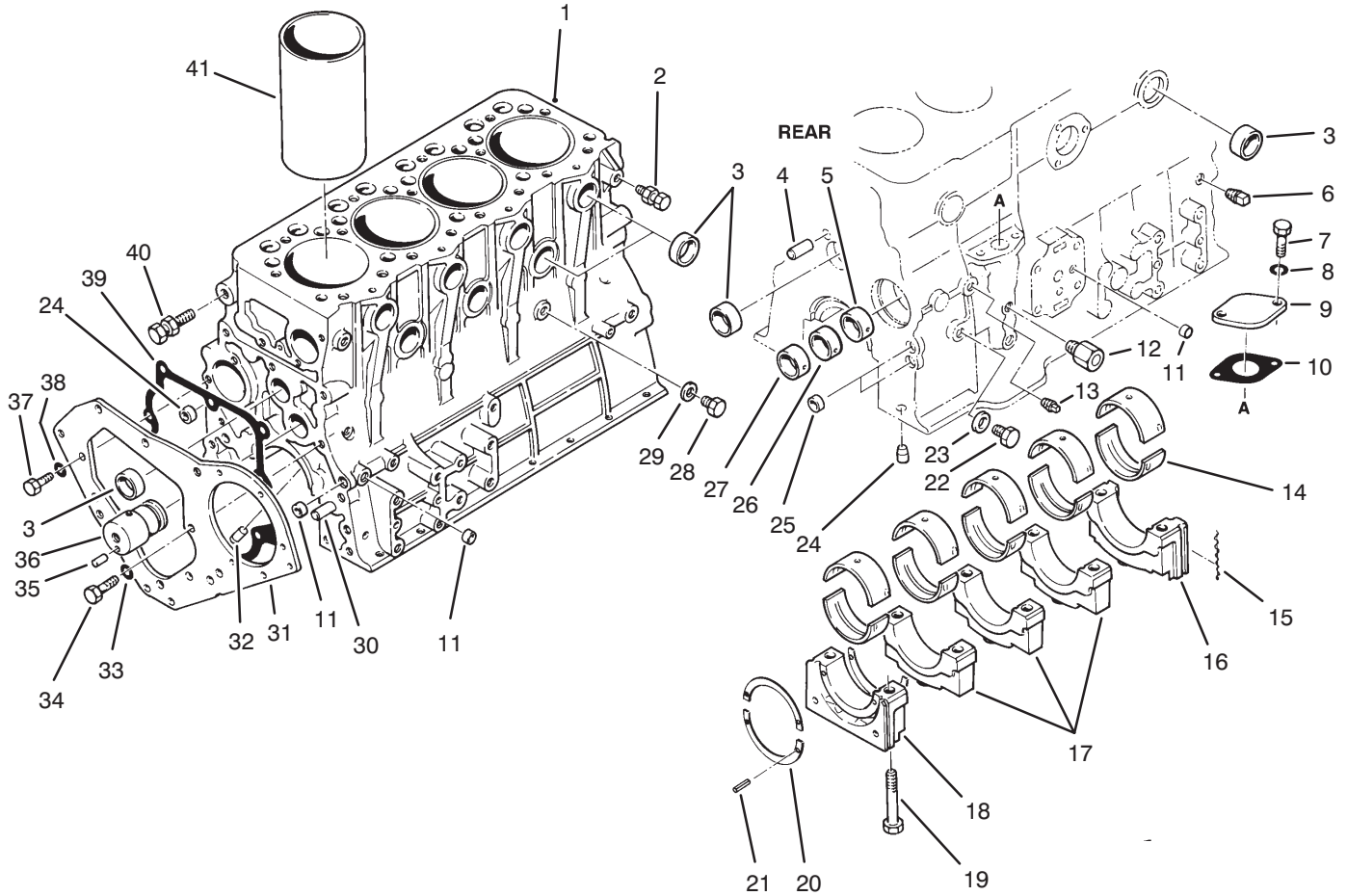

T-0585

CRANKCASE ASSEMBLY

Ref. No.	Part No.	Description	No. Used
1	70-5960	Crankcase Assembly (Incl. Ref. #2-6, 11, 13, 15-19, 21-30, 32, 35-36, & 40-41)	1
2	51-5580	Hanger	1
3	51-5600	Cap	11
4	70-3000	Pin	2
5	51-5500	Bushing No. 1	1
6	70-3400	Plug	6
7	60-7280	Bolt	2
8	51-7250	Washer	2
9	51-6480	Cover	1
†10	51-6490	Gasket	1
11	70-3350	Cap	6
12	70-5950	Connector	1
13	70-3410	Plug	1
14	70-5350	Bearing - Main (Std.)	10
14	70-5351	Bearing - Main U.S. 0.25mm	10
14	70-5352	Bearing - Main U.S. 0.50mm	10
14	70-5353	Bearing - Main U.S. 0.75mm	10
‡15	70-5240	Seal	4
16		Cap - Bearing No. 1	1
17		Cap - Bearing No. 2,3, & 4	3
18		Cap - Bearing No. 5	1
19	70-5300	Bolt	10
20	70-5360	Plate - Thrust (Std.)	3

Ref. No.	Part No.	Description	No. Used
20	70-5361	Plate - Thrust O.S. 0.15mm	3
20	70-5362	Plate - Thrust O.S. 0.30mm	3
20	70-5363	Plate - Thrust O.S. 0.45mm	3
21	51-5650	Pin	6
22	70-3120	Plug	1
†23	70-3080	Gasket	1
24		Plug	2
25	70-3370	Cap	3
26	51-5510	Bushing - No. 2	1
27	51-5520	Bushing - No. 3	1
28	51-8280	Bolt	1
†29	51-8270	Washer	1
30	70-5320	Pin	2
31	70-5250	Plate	1
32	70-5340	Valve	4
33	51-6390	Washer	1
34	70-2890	Bolt	1
35	51-5650	Pin	1
36	51-5640	Idler Shaft Assembly (Incl. Ref. #35)	1
37	60-7110	Bolt	1
38	51-7250	Washer	1
†39	70-5260	Gasket	1
40	70-5290	Hanger	1
41	70-5280	Sleeve	4

†Included in Gasket Set No. 70-6950

‡Included In Oil Seal Kit No. 70-6960

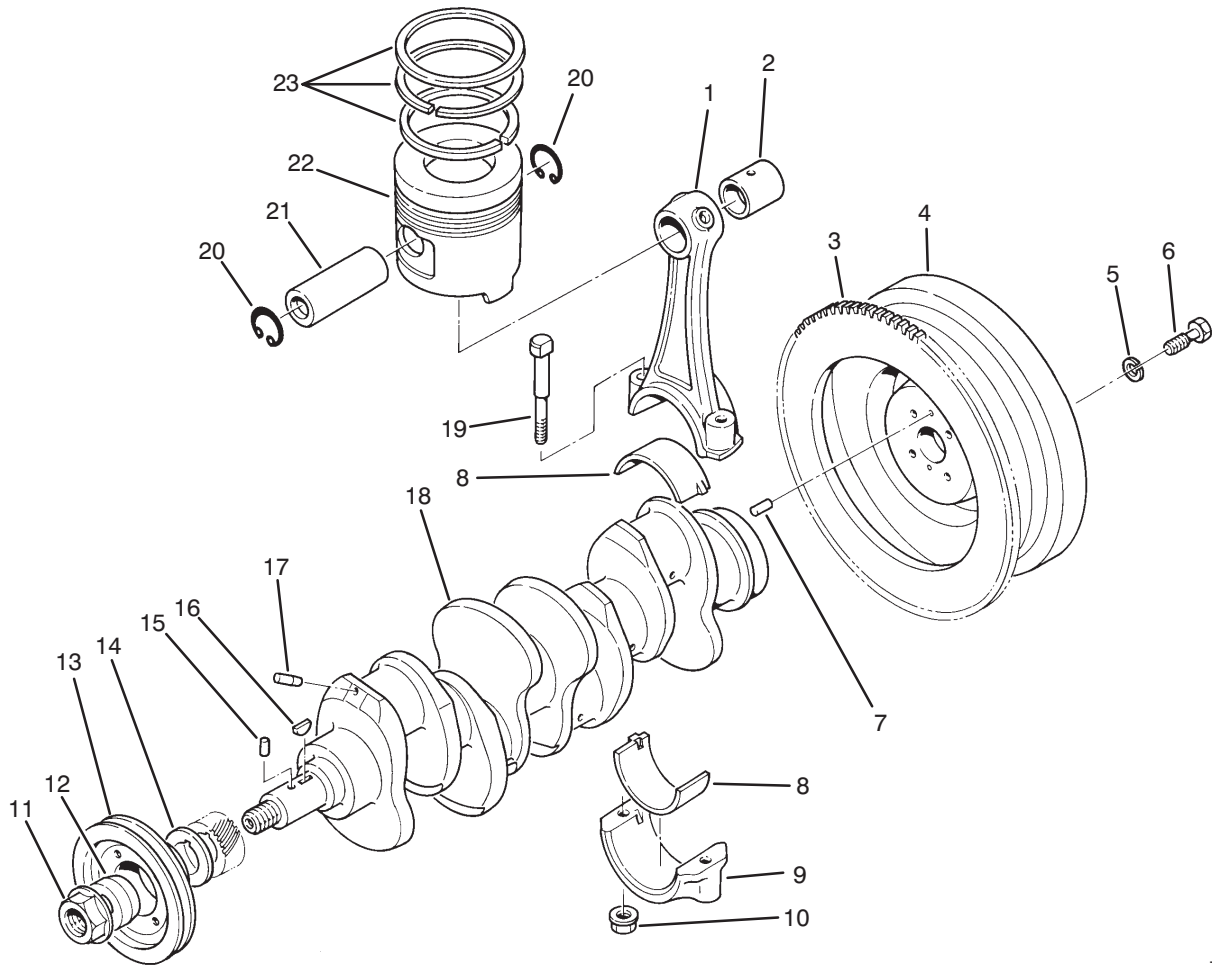

T-0586

PISTON, CONNECTING ROD, CRANKSHAFT & FLYWHEEL

Ref. No.	Part No.	Description	No. Used
1	70-5990	Connecting Rod - Std. (Incl. Ref. #2, 8-10 & 19)	4
2	70-6000	Bushing	4
3	51-6350	Gear	1
4	70-6030	Flywheel Assembly (Incl. Ref. #3)	1
5	51-8610	Washer - Lock	4
6	70-2880	Bolt	4
7	70-5800	Pin	2
8	70-5430	Bearing - Rod (Std.)	8
9		Cap	4
10	70-5420	Nut	8
11	70-3170	Nut	1
12	70-5820	Cone	1
13	70-5440	Pulley	1
14	70-5810	Plate	1
15	51-5650	Pin	1

Ref. No.	Part No.	Description	No. Used
16	51-5460	Key	1
17		Plug	2
18	70-6020	Crankshaft Assembly (Incl. Ref. #7, 11, & 15-17)	1
19	70-6010	Bolt	8
20	70-3020	Ring	8
21	70-5410	Pin	4
22	70-5980	Piston (Std.)	4
23	70-5400	Ring Set - Std.	4
*	70-5401	Ring Set - O.S. 0.25mm	4
*	70-5402	Ring Set - O.S. 0.50mm	4
*	70-5431	Bearing - Rod U.S. 0.25mm	4
*	70-5432	Bearing - Rod U.S. 0.50mm	4
*	70-5433	Bearing - Rod U.S. 0.75mm	4
*	70-5981	Piston - O.S. 0.25mm	4
*	70-5982	Piston - O.S. 0.50mm	4

*Not Illustrated

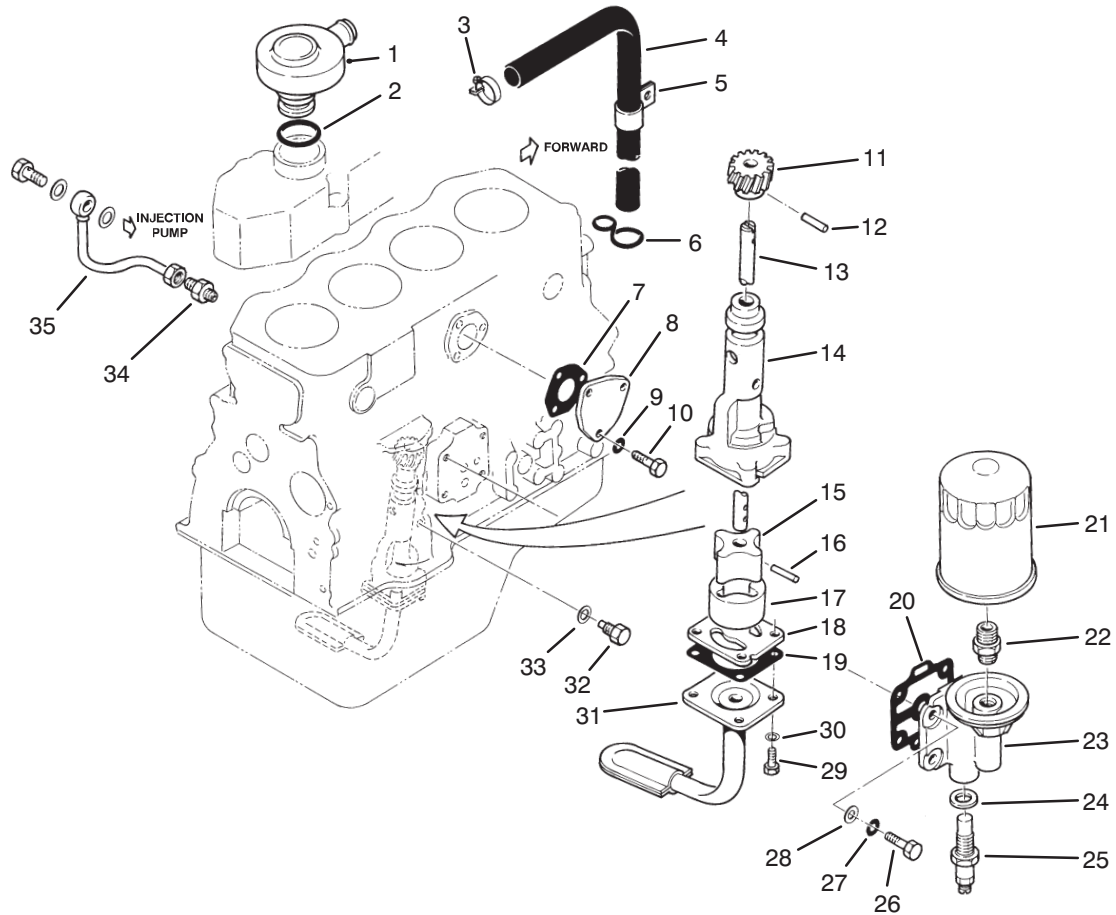

T-0587

OIL PUMP, BREATHER & FILTER

Ref. No.	Part No.	Description	No. Used
1	70-5570	Breather	1
†2	70-3220	O-Ring	1
3	70-3090	Clamp	1
4	70-3030	Tube	1
5	70-3420	Clip	1
6	70-5580	Stay	1
†7	70-5100	Gasket	1
8	70-5270	Cover	1
9	51-7250	Washer	3
10	60-7110	Bolt	3
11		Gear	1
12		Pin	1
13		Shaft	1
14	70-5840	Oil Pump Assembly (Incl. Ref. #11-13, 15-18 & 29-30)	1
15		Rotor	1
16		Pin	2
17		Rotor	1
18	70-5850	Cover	1

Ref. No.	Part No.	Description	No. Used
†19	70-5510	Gasket	1
†20	70-5550	Gasket	1
21	49-2500	Element Assembly	1
22	70-5520	Union	1
23	70-5530	Bracket Assembly (Incl. Ref. #22, 24 & 25)	1
24	51-6820	Washer	1
25	51-6830	Relief Valve Assembly	1
26	60-7480	Bolt	4
27	51-6390	Washer - Lock	4
28	70-2990	Washer	4
29	60-7290	Bolt	4
30	51-7400	Washer	4
31	70-5500	Strainer	1
32	70-5120	Bolt	1
†33	70-3070	Gasket	1
34	70-3340	Connector	1
35	70-5030	Pipe	1
*	70-5540	Oil Filter Assembly (Incl. Ref. #21-25)	1

†Included in Gasket Set No. 70-6950

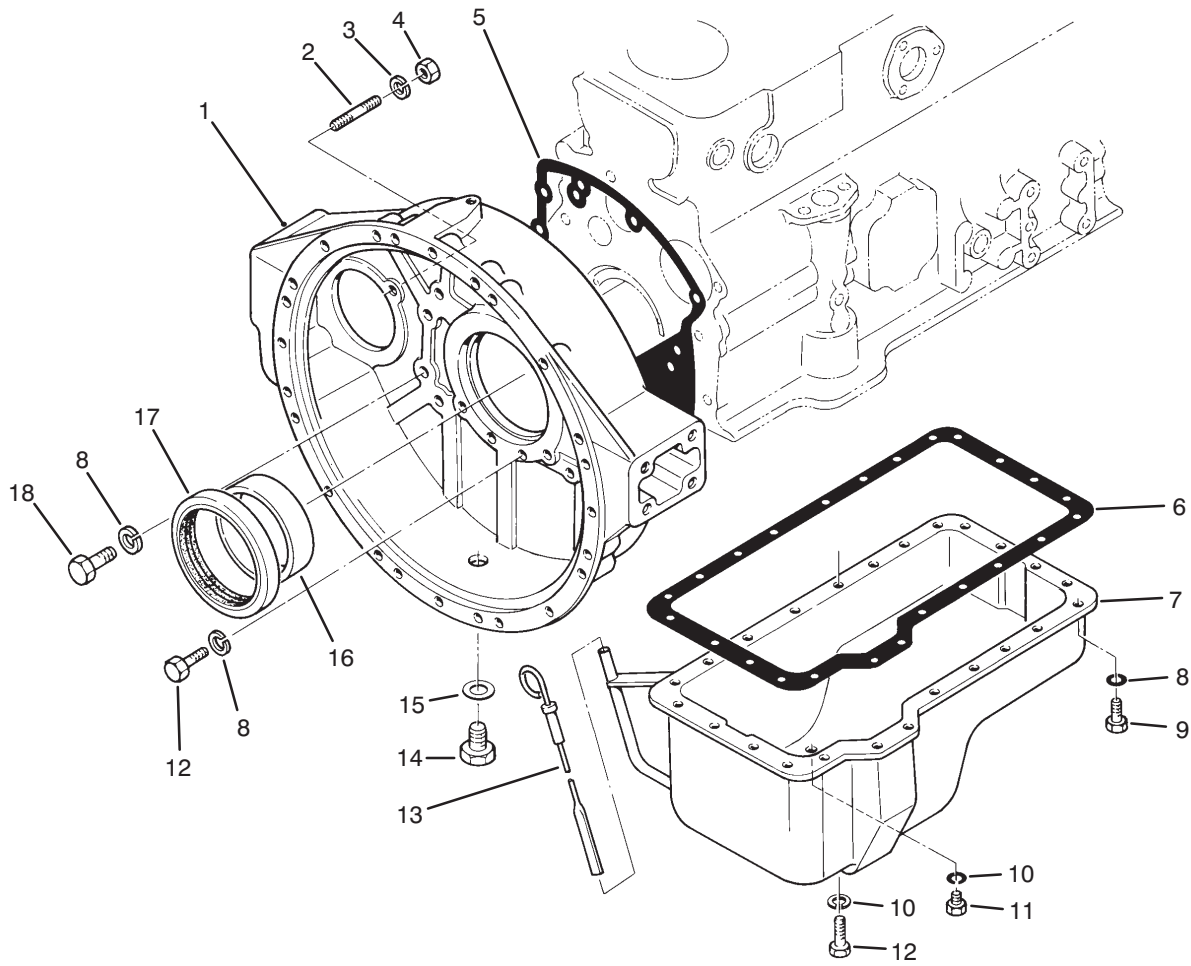

T-0588

FLYWHEEL HOUSING & OIL PAN ASSEMBLY

Ref. No.	Part No.	Description	No. Used
1	70-5970	Housing	1
2	51-5950	Stud	2
3	51-6390	Washer - Lock	13
4	51-5970	Nut	2
†5	70-5330	Gasket	1
†6	70-5390	Gasket	1
7	70-5380	Pan - Oil (Incl. Ref. #10 & 11)	1
8	51-7250	Washer - Lock	28
9	60-7280	Bolt	23

Ref. No.	Part No.	Description	No. Used
†10	70-3470	Washer - Drain Plug	1
11	70-3110	Plug - Drain	1
12	60-7370	Bolt	5
13	70-5560	Gage	1
14	70-3230	Plug	1
†15	51-6890	Gasket - Plug	1
16		Sleeve	1
‡17	51-5890	Oil Seal Assembly (Incl. Ref. #16)	1
18	70-2900	Bolt	11

†Included in Gasket Set No. 70-6950

‡Included In Oil Seal Kit No. 70-6960

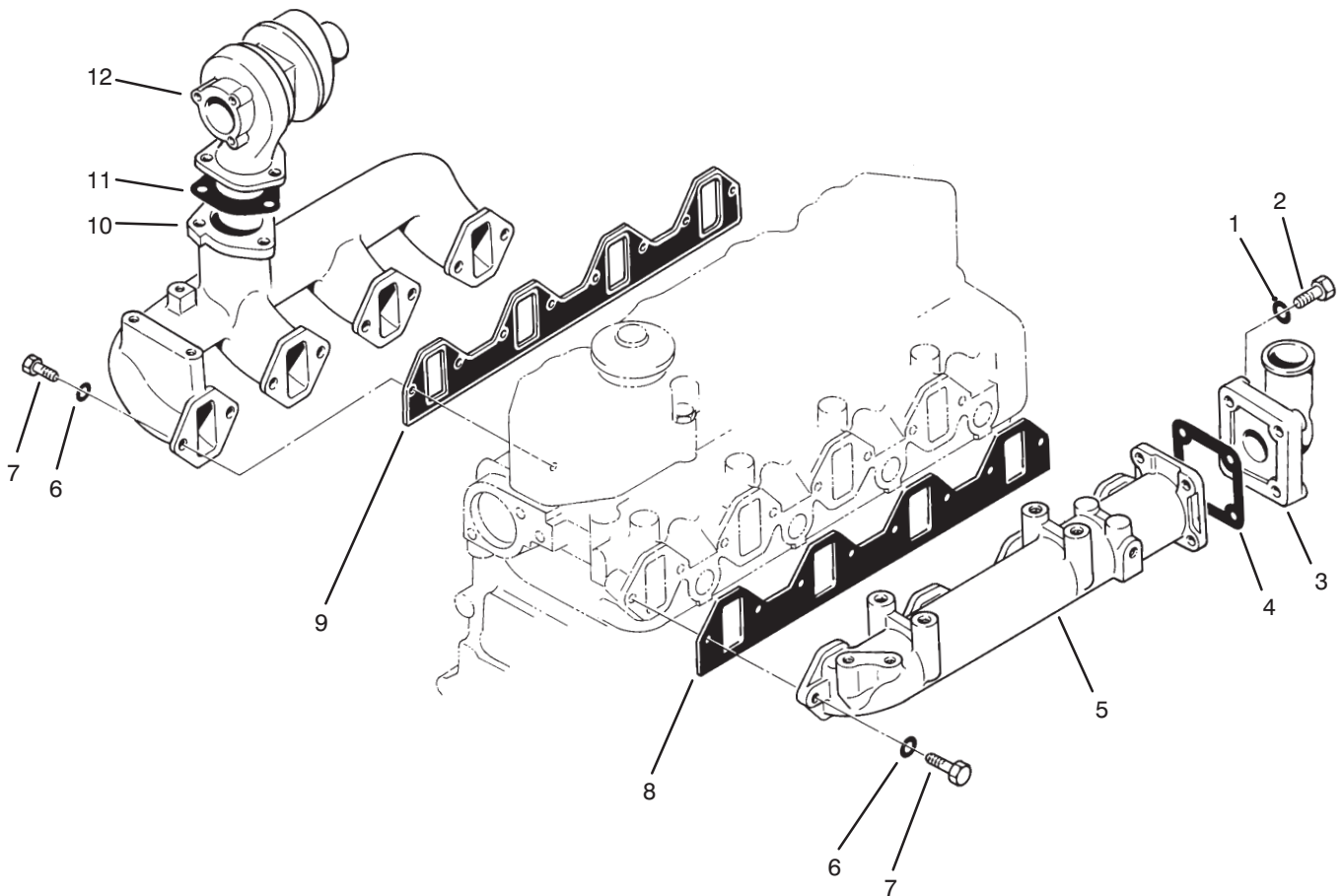

T-0590

INTAKE & EXHAUST MANIFOLD ASSEMBLY

Ref. No.	Part No.	Description	No. Used
1	51-7250	Washer	4
2	60-7370	Bolt	4
3	70-6090	Elbow	1
†4	70-3130	Gasket	1
5	70-6050	Manifold	1
6	51-7250	Washer	16

Ref. No.	Part No.	Description	No. Used
7	60-7370	Bolt	16
†8	70-6060	Gasket	1
†9	70-5460	Gasket	1
10	70-5470	Manifold	1
†11	70-6250	Gasket	1
12	70-6430	Turbocharger Assembly	1

†Included in Gasket Set No. 70-6950

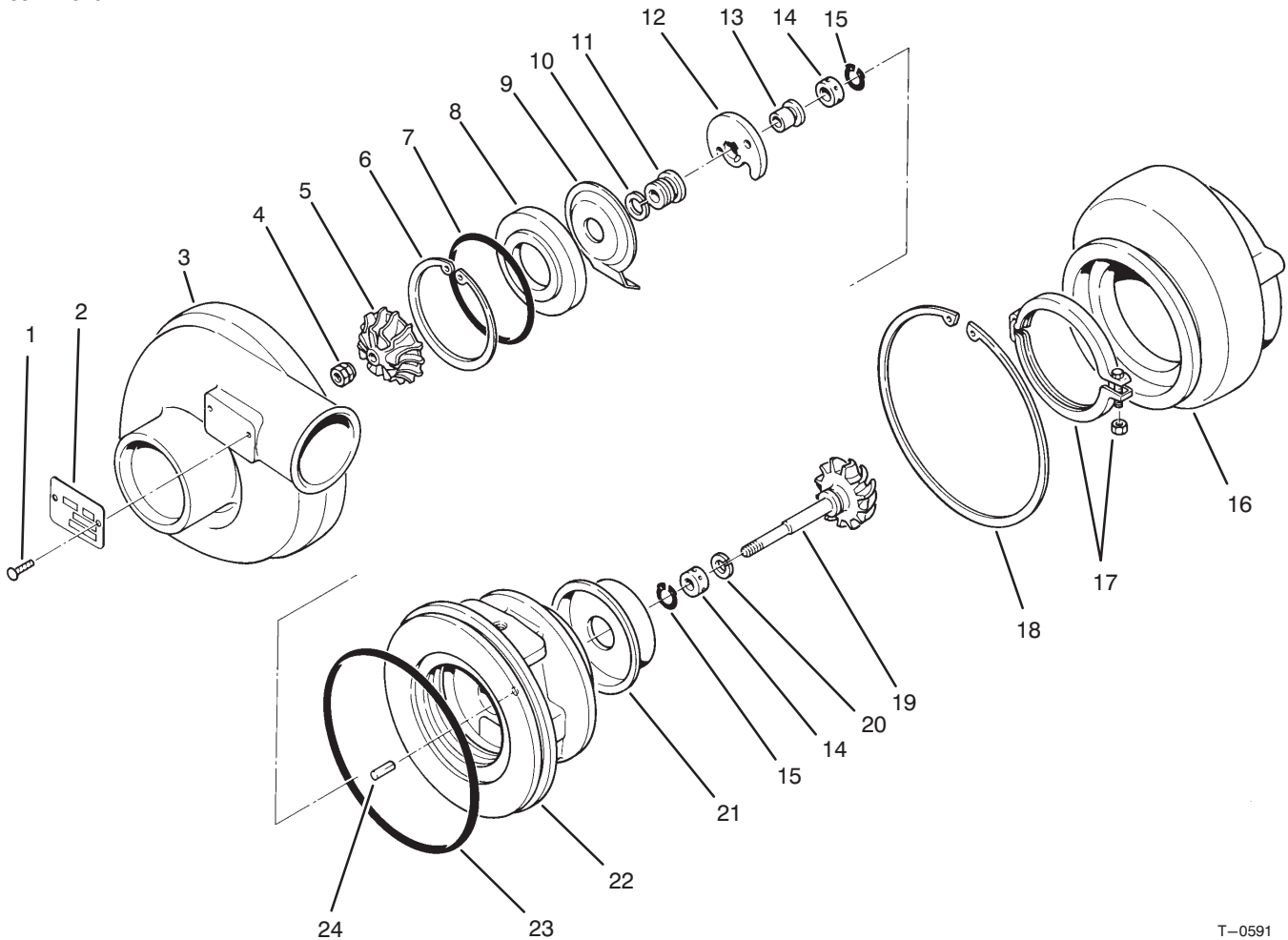

T-0591

TURBOCHARGER ASSEMBLY NO. 70-6430

Ref. No.	Part No.	Description	No. Used
1	60-7160	Rivet	2
2	70-6360	Plate	1
3	70-6340	Cover	1
4	70-6330	Nut	1
5	70-6320	Wheel	1
6	70-6300	Ring	1
7	70-6270	O-Ring	1
8	70-6290	Insert	1
9	70-6280	Deflector	1
10	70-6310	Ring	1
11	70-6410	Sleeve	1
12	70-6380	Bearing	1
13	70-6420	Ring	1
14	70-6370	Bearing	2

Ref. No.	Part No.	Description	No. Used
15	70-6390	Ring	2
16	70-6450	Housing	1
17	70-6230	Coupling Assembly	1
18	70-6400	Ring	1
19	70-6470	Shaft & Turbine Wheel Assy.	1
20	70-6350	Ring	1
21	70-6260	Plate	1
22	70-6460	Bearing Housing Assembly (Incl. Ref. #24)	1
23	70-3010	O-Ring	1
24		Pin	1
*	70-6440	Cartridge Assembly (Incl. Ref. #4-15 & 19-24)	1

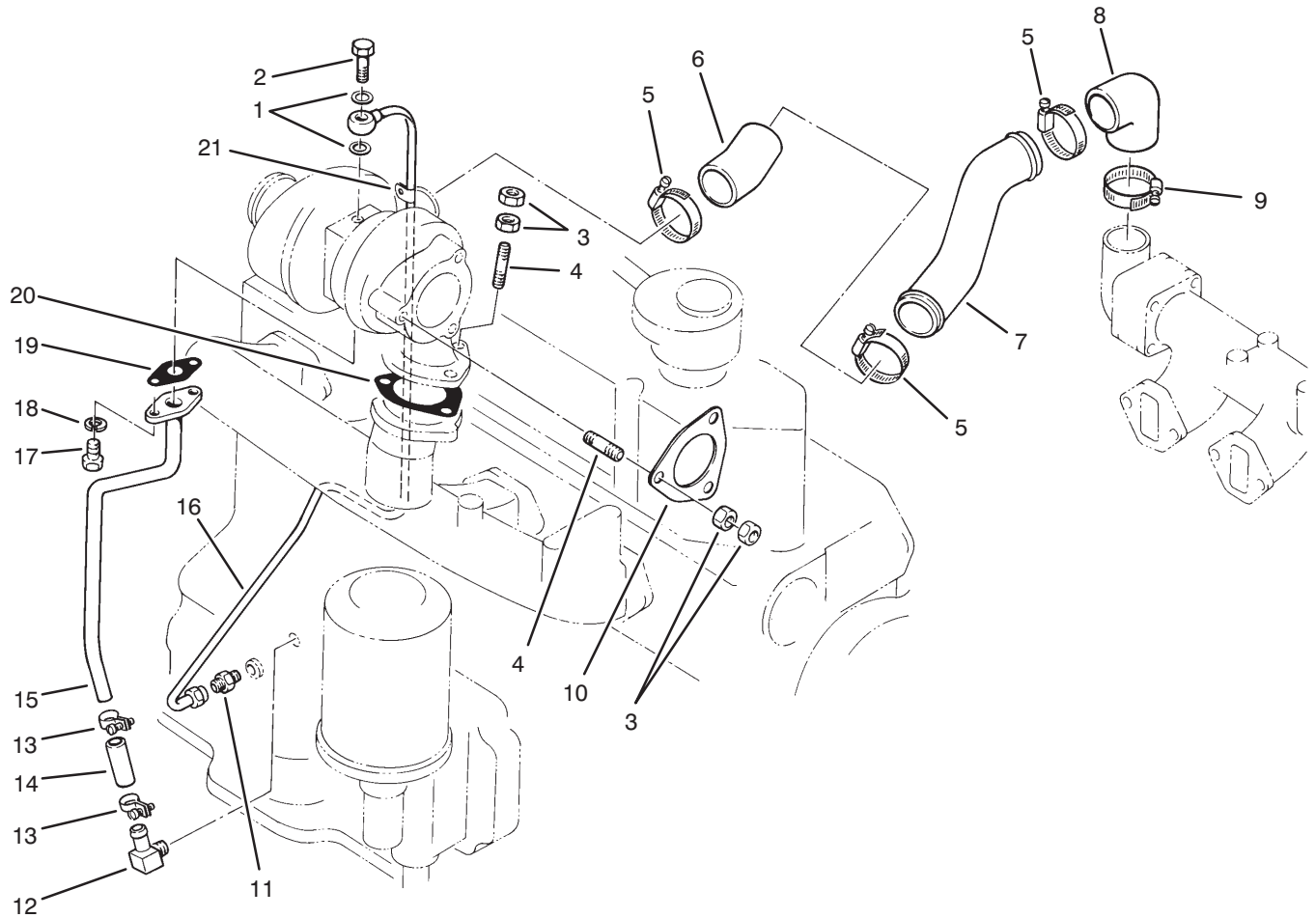

T-0592

TURBOCHARGER OIL PIPE ASSEMBLY

Ref. No.	Part No.	Description	No. Used
†1	70-3060	Gasket	2
2	70-4980	Bolt - Cap Hex Hd.	1
3	60-7120	Nut - Hex.	12
4	70-3480	Stud	6
5	70-3430	Clamp - Hose	3
6	70-6080	Hose	1
7	70-6070	Pipe	1
8	70-4950	Hose - 90° Elbow	1
9	70-3440	Clamp - Hose	1
10	70-6240	Gasket	1
11	70-3340	Connector	1

Ref. No.	Part No.	Description	No. Used
12	70-5310	Fitting - 90° Elbow	1
13	70-3090	Clamp - Hose	2
14	70-3040	Hose	1
15	70-5490	Pipe - Oil	1
16	70-5480	Pipe - Oil	1
17	70-2830	Bolt - Cap Hex. Hd.	2
18	51-7400	Washer - Lock	2
19	70-4970	Gasket	1
†20	70-6250	Gasket	1
21	70-4960	Clamp - R	1

†Included in Gasket Set No. 70-6950

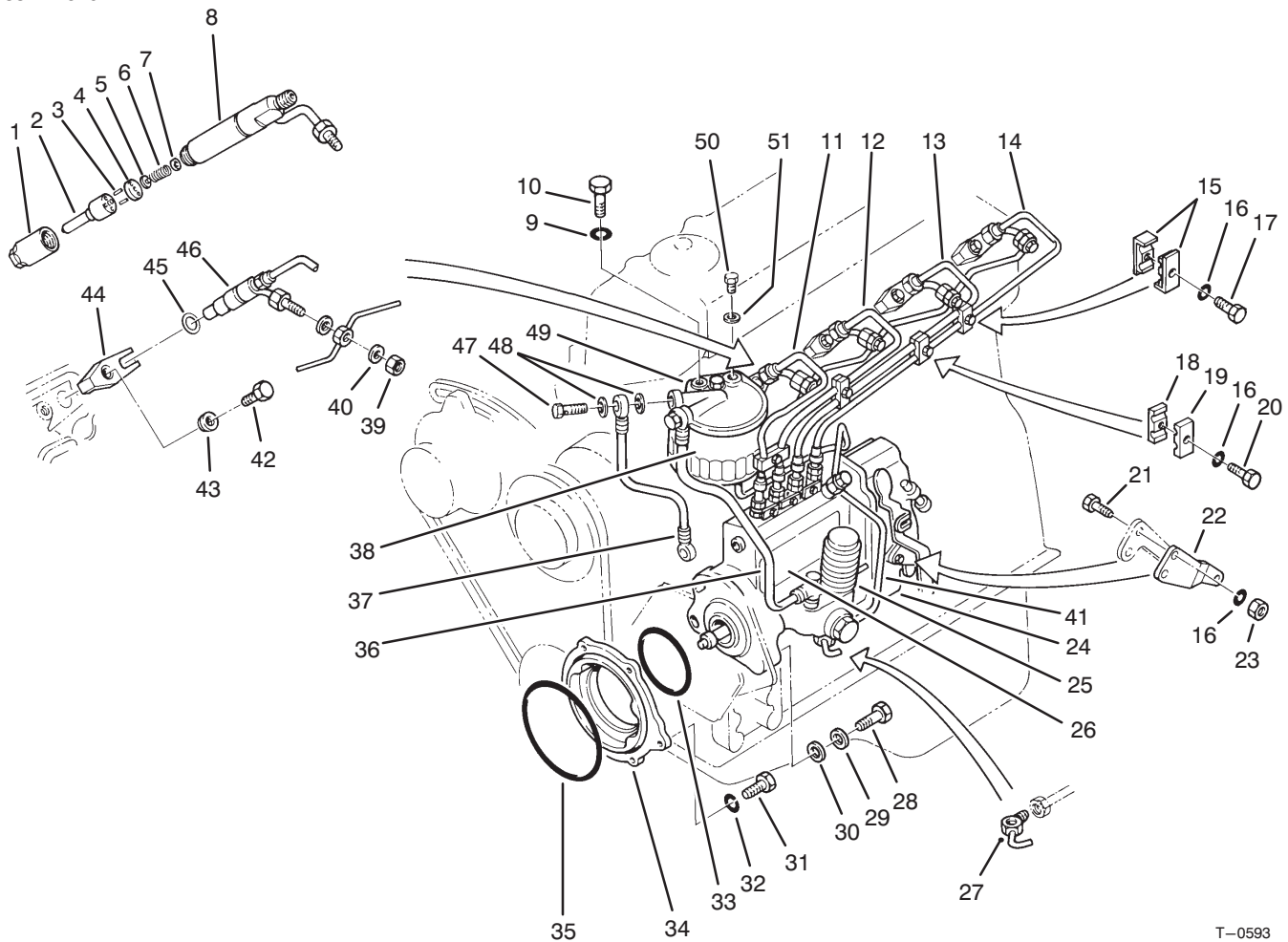

T-0593

FUEL SYSTEM ASSEMBLY

Ref. No.	Part No.	Description	No. Used
1	70-4840	Nut	4
2	70-6170	Nozzle Tip Assembly	4
3	70-6830	Pin	8
4	70-4930	Packing	4
5	70-4820	Pin	4
6	70-4830	Spring	4
7	70-4860	Washer 1.00 mm	A/R
*	70-4870	Washer 1.05 mm	A/R
*	70-4880	Washer 1.10 mm	A/R
*	70-4850	Washer 2.15 mm	A/R
*	70-4890	Washer 1.275 mm	A/R
*	70-4900	Washer 1.325 mm	A/R
*	70-4910	Washer 1.775 mm	A/R
*	70-4920	Washer 0.95 mm	A/R
8	70-4810	Body Assembly	4
9	51-6390	Washer - Lock	2
10	60-7480	Bolt	2
11	70-6190	Pipe - No. 1	1
12	70-6100	Pipe - No. 2	1
13	70-6200	Pipe - No. 3	1
14	70-6110	Pipe - No. 4	1
15	60-5210	Clamp	2
16	51-7400	Washer - Lock	6
17	70-2840	Bolt	1

Ref. No.	Part No.	Description	No. Used
18	70-3180	Clamp	3
19	70-3190	Clamp	3
20	70-2830	Bolt	3
21	70-2820	Bolt	2
22	70-5770	Lever	1
23	70-2960	Nut	2
24		Governor	1
25	70-5700	Fuel Feed Pump	1
26	70-6180	Injection Pump (Incl. Ref. #24 & 25)	1
27	70-5060	Joint	1
28	51-4910	Bolt	4
29	51-6390	Washer	4
30	70-2990	Washer	4
31	60-7280	Bolt	2
32	51-7250	Washer - Lock	2
†33	70-6130	O-Ring	1
34	70-6210	Flange	1
†35	70-5070	O-Ring	1
36	70-3140	Pipe	1
37	70-3150	Pipe	1
38	70-5730	Filter Element Assembly	1
39	70-2980	Nut	4
†40	70-3460	Washer	8

*Not Illustrated

†Included in Gasket Set No. 70-6950

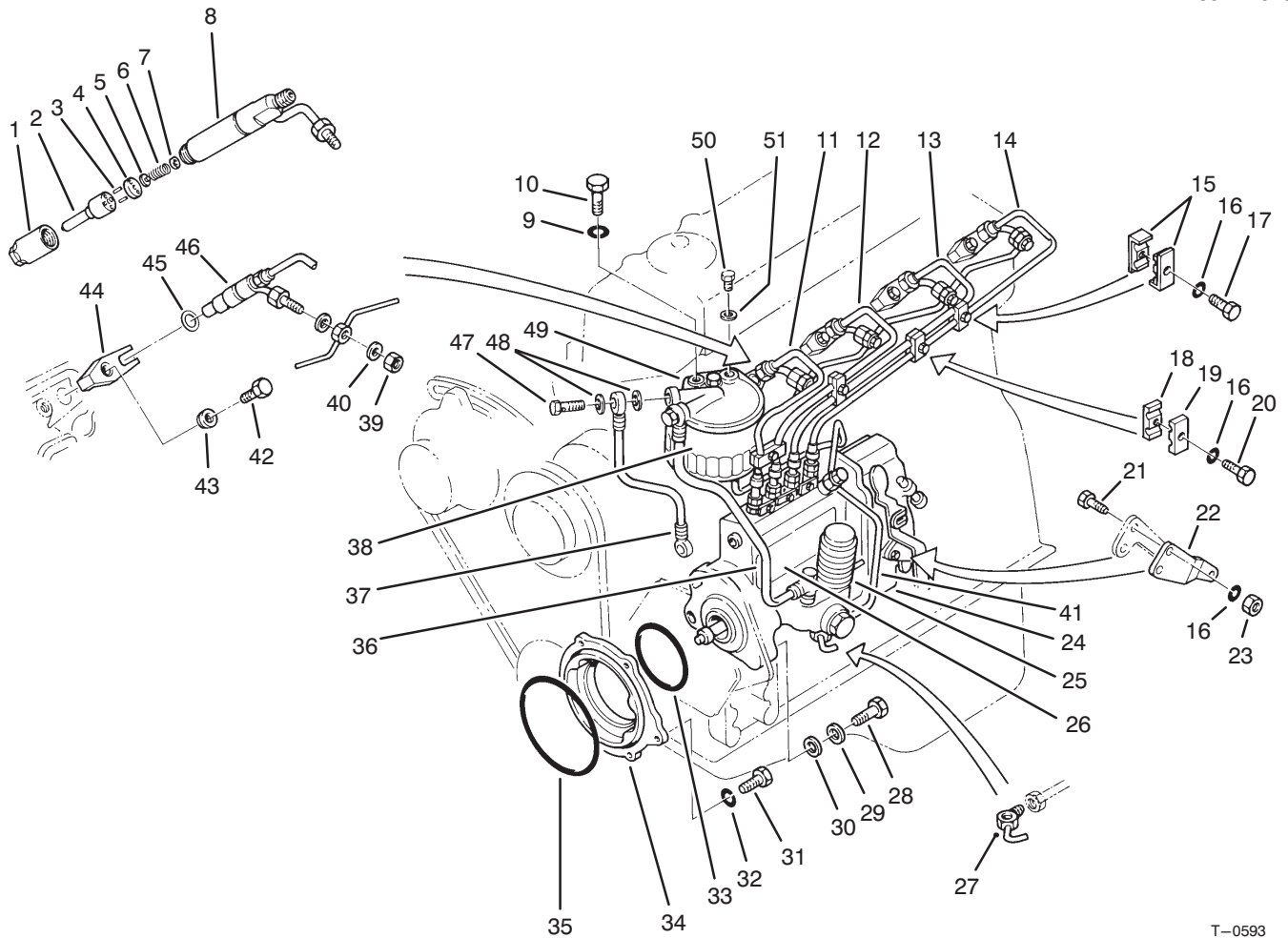

T-0593

FUEL SYSTEM ASSEMBLY (Continued)

Ref. No.	Part No.	Description	No. Used	Ref. No.	Part No.	Description	No. Used
41	70-6120	Pipe	1	47	70-3250	Bolt	2
42	70-2850	Bolt	4	48	70-3210	Packing	4
43	70-6140	Washer	4	49	70-5720	Bracket	1
44	70-6220	Gland	4	50	70-3200	Washer	1
†45	70-6150	Gasket	4	51	70-3240	Plug	1
46	70-6160	Nozzle Assembly (Incl. Ref. #1-8)	4	*	70-5710	Fuel Filter Assembly (Incl. Ref. #38 & 47-51)	1

*Not Illustrated

†Included in Gasket Set No. 70-6950

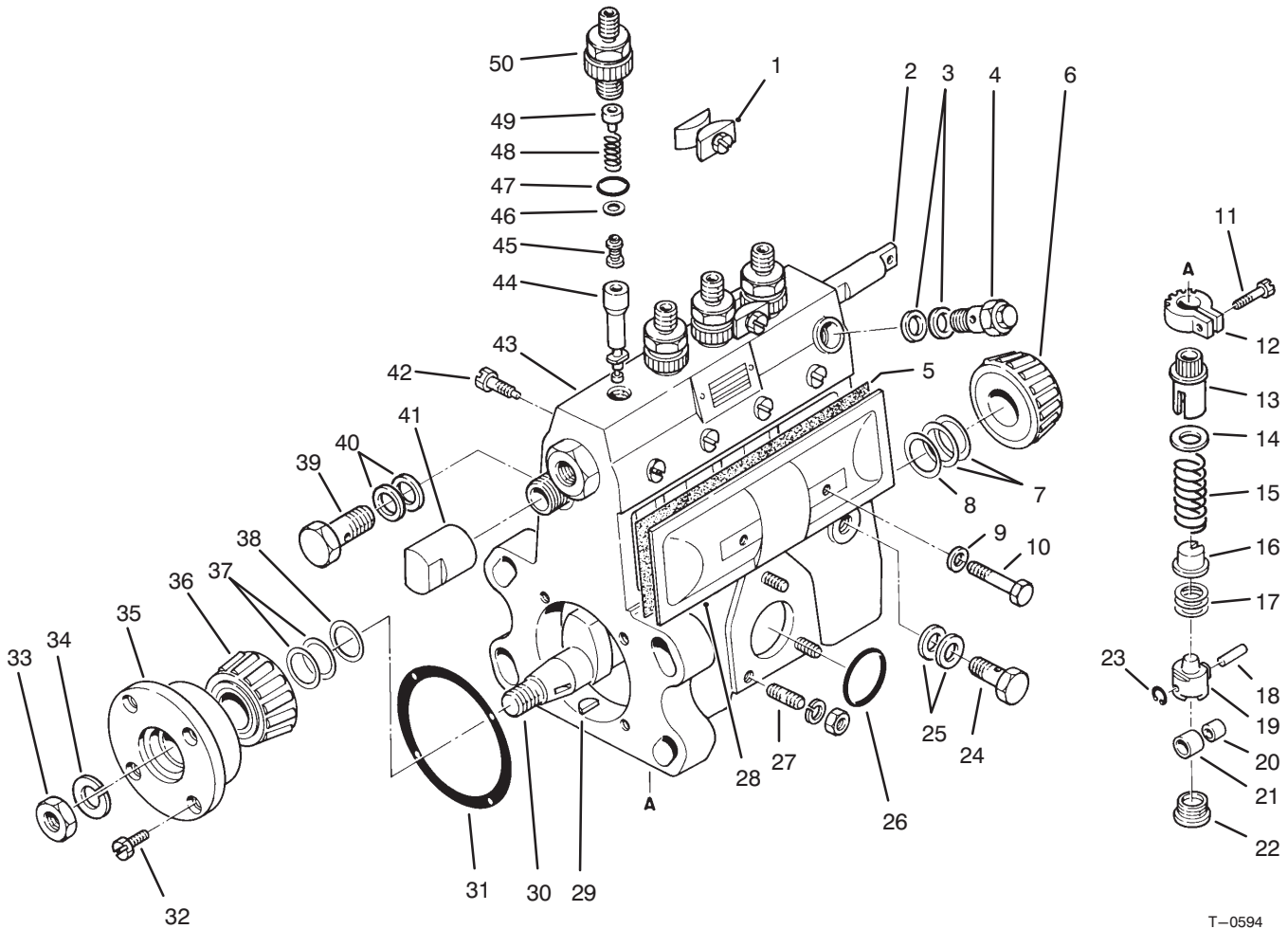

T-0594

FUEL INJECTION PUMP ASSEMBLY

Ref. No.	Part No.	Description	No. Used
1	70-3880	Plate	2
2	70-3840	Rack	1
3	70-3860	Washer	2
4	70-3960	Valve	1
5	70-3930	Gasket	1
6	70-6850	Bearing	2
7	70-3710	Plate - 0.10	A/R
*	70-3720	Plate - 0.12	A/R
*	70-3730	Plate - 0.14	A/R
*	70-3740	Plate - 0.16	A/R
*	70-3750	Plate - 0.18	A/R
*	70-3760	Plate - 0.50	A/R
*	70-3770	Plate - 0.30	A/R
8	70-3690	Ring	1
9	70-3900	Packing	2
10	70-3950	Screw	2
11	70-3570	Screw	4
12	70-3560	Pinion	4
13	70-3580	Sleeve	4
14	70-3590	Seat	4
15	70-3600	Spring	4
16	70-3610	Seat	4

Ref. No.	Part No.	Description	No. Used
17	70-3970	Plate - 0.6	A/R
*	70-3980	Plate - 0.7	A/R
*	70-3990	Plate - 0.8	A/R
*	70-4000	Plate - 0.9	A/R
*	70-4010	Plate - 1.0	A/R
*	70-4020	Plate - 1.1	A/R
*	70-4030	Plate - 1.2	A/R
*	70-4040	Plate - 1.3	A/R
*	70-4050	Plate - 1.4	A/R
*	70-4060	Plate - 0.1	A/R
*	70-4070	Plate - 0.2	A/R
*	70-4080	Plate - 0.3	A/R
*	70-4090	Plate - 0.4	A/R
*	70-4100	Plate - 0.5	A/R
*	70-4110	Plate - 0.15	A/R
18	70-3640	Pin	4
19	70-3620	Body	4
20	70-3650	Bushing	4
21	70-3660	Roller	4
22	70-3670	Plug	4
23	70-6800	E-Ring	4
24	70-6930	Screw	1

*Not Illustrated

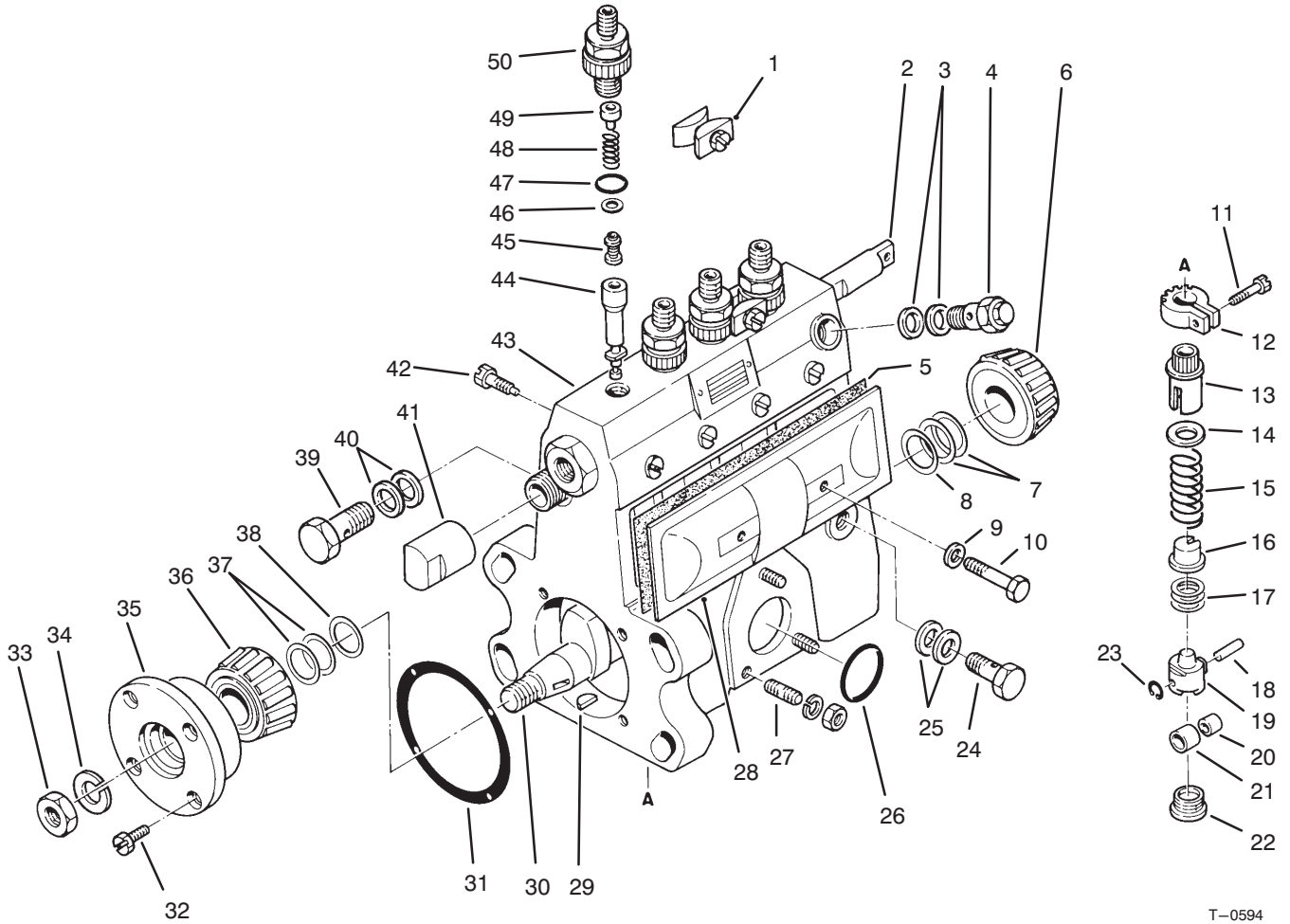

T-0594

FUEL INJECTION PUMP ASSEMBLY (Continued)

Ref. No.	Part No.	Description	No. Used
25	70-3910	Washer	2
26	70-6900	O-Ring	1
27	70-6720	Stud	3
28	70-3940	Plate	2
29	70-6880	Key	1
30	70-3680	Camshaft	1
31	70-3830	Gasket	1
32	70-6540	Bolt	4
33	70-6780	Nut	1
34	70-6680	Washer	1
35	70-3820	Cover	1
36	70-6840	Bearing	1
37	70-3780	Plate - 0.1	A/R
*	70-3790	Plate - 0.15	A/R
*	70-3800	Plate - 0.3	A/R
*	70-3810	Plate - 0.5	A/R
38	70-3700	Ring	1

Ref. No.	Part No.	Description	No. Used
39	70-6940	Screw	1
†40	70-3870	Washer	2
41	70-3490	Cover	1
42	70-3850	Screw	1
43	70-4940	Housing Assembly (Incl. Ref. #27)	1
44	70-3550	Element Assembly	4
45	70-3540	Valve Assembly	4
46	70-3530	Gasket	4
47	70-6910	O-Ring	4
48	70-3520	Spring	4
49	70-3510	Stopper	4
50	70-3500	Holder	4
*	70-3920	Cover Assembly (Incl. Ref. #5, 9-10 & 28)	1
*	70-3630	Tappet Assembly (Incl. Ref. #18-21 & 23)	1

*Not Illustrated

†Included in Gasket Set No. 70-6950

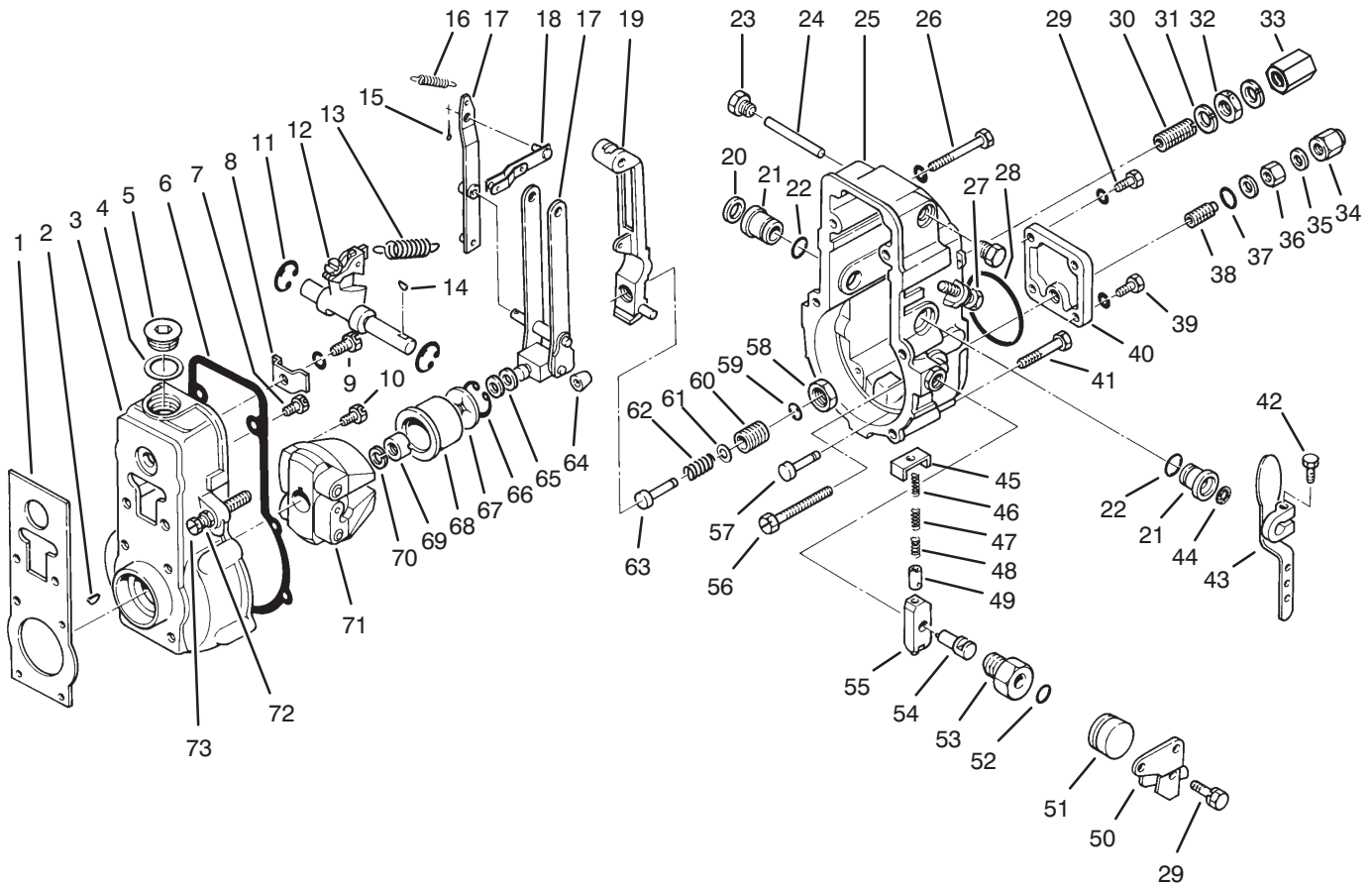

T-0595

GOVERNOR ASSEMBLY

Ref. No.	Part No.	Description	No. Used
1	70-4160	Gasket	1
2	70-6870	Key	1
3	70-4130	Housing	1
4	70-6710	Washer	1
5	70-4590	Plug	1
6	70-4150	Gasket	1
7	70-6530	Bolt	5
8	70-4210	Plate	1
9	70-6550	Bolt	1
10	70-6520	Bolt	1
11	70-6810	E-Ring	2
12	70-4220	Swiveling Lever Assembly	1
13	70-4370	Spring	1
14	70-6860	Key	1
15	70-6480	Pin	1
16	70-4380	Spring	1
17	70-4320	Lever Assembly	1
18	70-4340	Shackle Assembly	1
19	70-4250	Tension Lever Assembly	1
20	70-4580	Cap	1
21	70-4230	Bushing	2
22	70-6510	O-Ring	2
23	70-4360	Plug	2
24	70-4350	Shaft	1
25	70-4400	Cover	1
26	70-6740	Bolt	2

Ref. No.	Part No.	Description	No. Used
27	70-4140	Stopper	1
28	70-6790	Packing	1
29	70-6520	Bolt & Washer	3
30	70-4120	Capsule	1
31	70-3890	Washer	2
32	70-4310	Nut	1
33	70-4440	Nut	1
34	70-4450	Nut	1
35	70-6690	Washer	2
36	70-6770	Nut	1
37	70-6500	O-Ring	1
38	70-4330	Bushing	1
39	70-6760	Bolt & Washer	2
40	70-4550	Plate	1
41	70-6750	Bolt	4
42	70-6730	Bolt	1
43	70-4560	Adjusting Lever Assembly	1
44	70-6920	Seal	1
45	70-4460	Plate	1
46	70-4500	Spring	1
47	70-4520	Spring	1
48	70-4510	Spring	1
49	70-4490	Cup	1
50	70-4570	Stop Lever Assembly	1
51	70-4530	Cover	1
52	70-6890	O-Ring	1

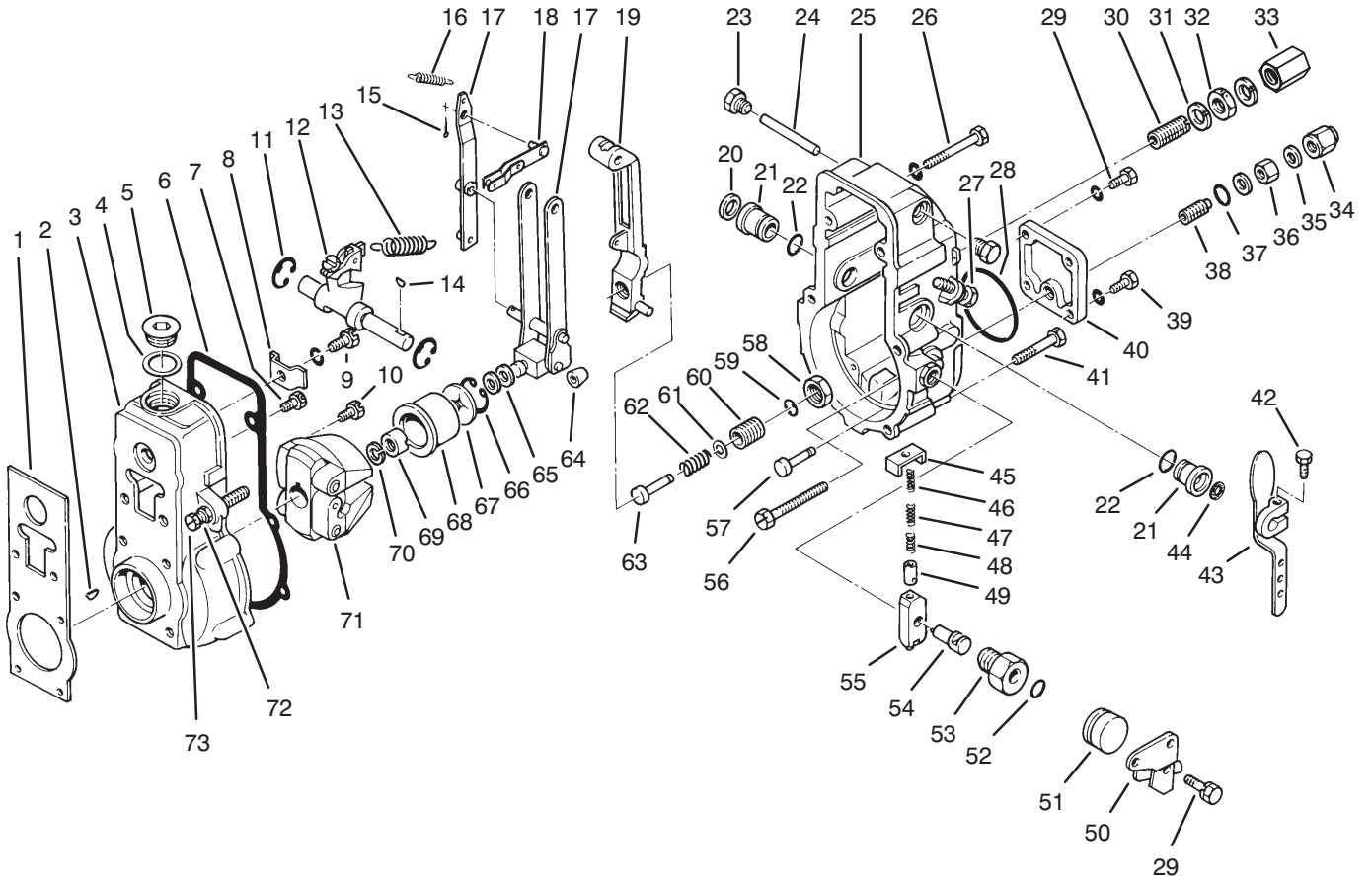

T-0595

GOVERNOR ASSEMBLY (Continued)

Ref. No.	Part No.	Description	No. Used
53	70-4420	Bushing	1
54	70-4480	Shaft	1
55	70-4470	Lever	1
56	70-4390	Screw	1
57	70-4410	Pin	1
58	70-4300	Nut	1
59	70-4240	E-Ring	1
60	70-4270	Screw	1
61	70-6570	Washer - 0.1	A/R
*	70-6600	Washer - 0.2	A/R
*	70-6580	Washer - 0.25	A/R
*	70-6590	Washer - 0.5	A/R
*	70-6660	Washer - 1.0	A/R
62	70-4280	Spring	1
63	70-4290	Adapter	1
64	70-4540	Slider	1

Ref. No.	Part No.	Description	No. Used
65	70-6610	Washer - 0.2	A/R
*	70-6620	Washer - 0.3	A/R
*	70-6630	Washer - 0.4	A/R
*	70-6640	Washer - 0.1	A/R
*	70-6650	Washer - 1.0	A/R
66	70-6490	Ring	1
67	70-4200	Plate	1
68	70-4190	Sleeve	1
69	70-4180	Nut	1
70	70-6670	Washer	1
71	70-4170	Flyweight Assembly	1
72	70-6560	Nut	2
73	70-4430	Screw	1
*	70-4260	Adapter Assembly (Incl. Ref. #59-63)	1

*Not Illustrated

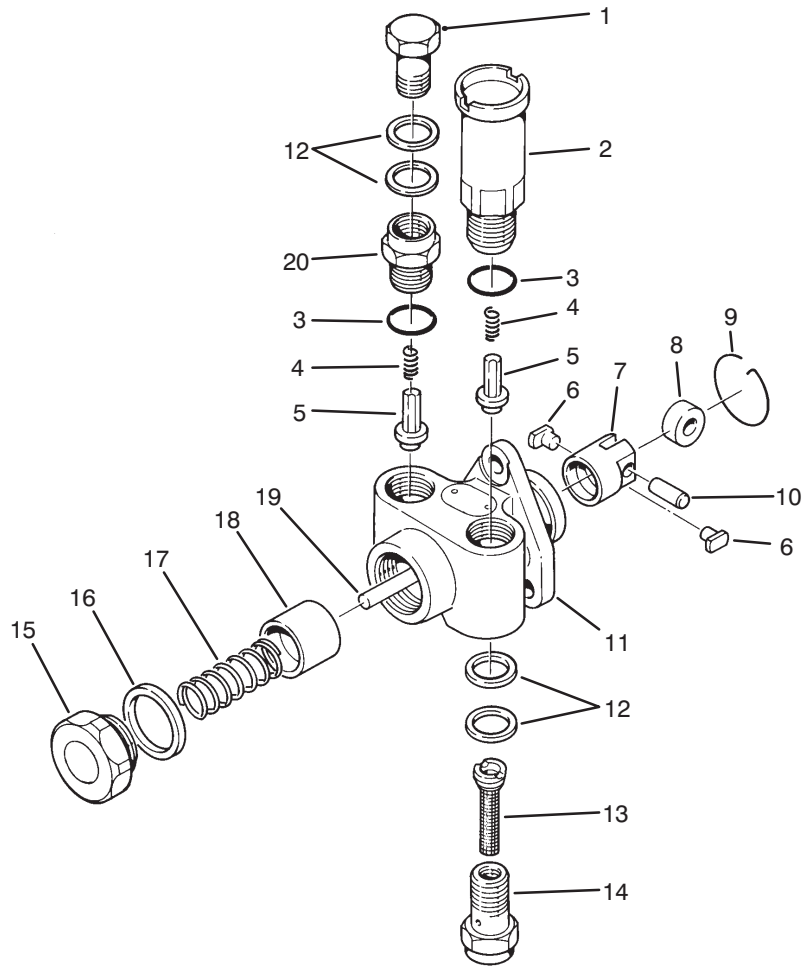

T-0596

FUEL FEED PUMP ASSEMBLY NO. 70-5700

Ref. No.	Part No.	Description	No. Used
1	70-6940	Screw	1
2	70-4650	Pump Assembly	1
3	70-4630	Gasket	2
4	70-4620	Spring	2
5	70-4610	Valve	2
6	70-4760	Block	2
7	70-4730	Tappet	1
8	70-4740	Roller	1
9	70-6820	Ring	1
10	70-4750	Pin	1
11	70-4600	Housing Assembly	1
†12	70-3870	Washer	4
13	70-4790	Filter	1

Ref. No.	Part No.	Description	No. Used
14	70-4800	Screw	1
15	70-4780	Plug	1
16	70-6700	Washer	1
17	70-4770	Spring	1
18	70-4720	Piston	1
19	70-4660	Rod, Blue Small Dia.	A/R
*	70-4670	Rod, Red Small Dia.	A/R
*	70-4680	Rod, Yellow Small Dia.	A/R
*	70-4690	Rod, Green Small Dia.	A/R
*	70-4700	Rod, White Small Dia.	A/R
*	70-4710	Rod, Brown Big Dia.	A/R
20	70-4640	Support	1

*Not Illustrated

†Included in Gasket Set No. 70-6950

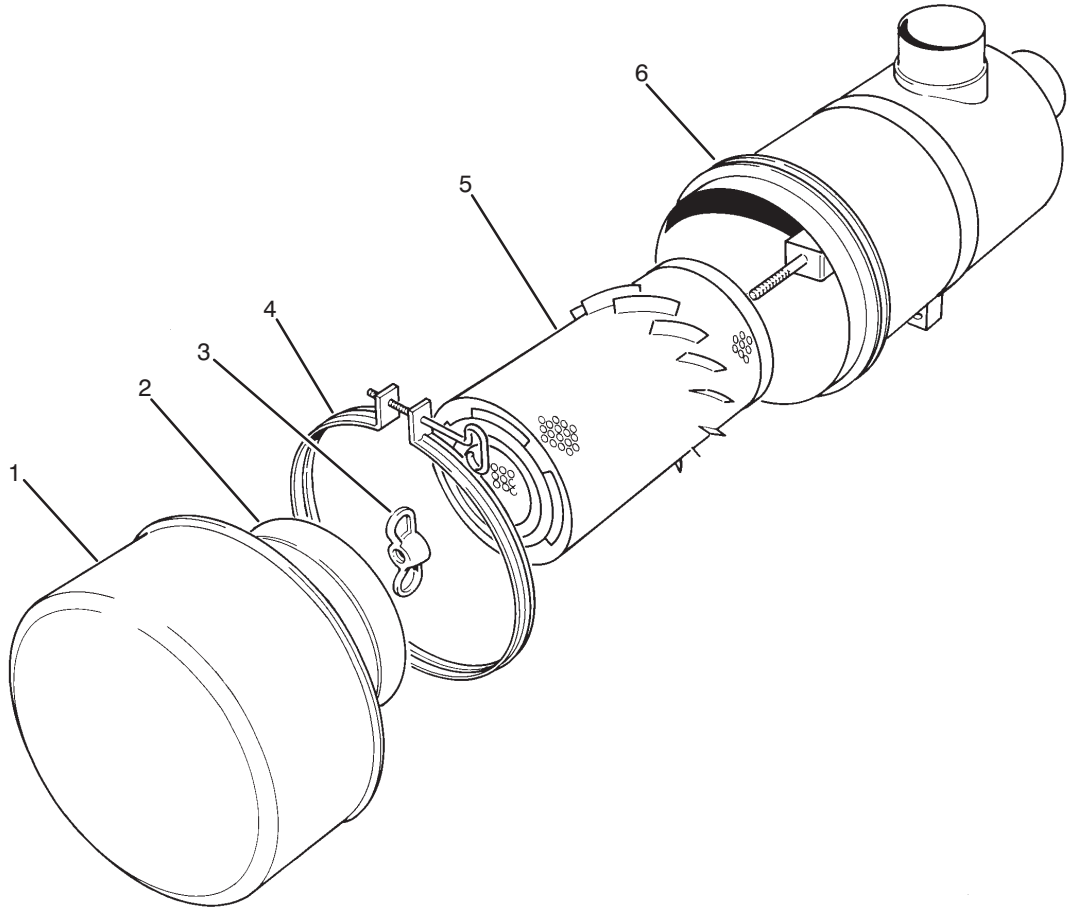

T-0387

AIR CLEANER ASSEMBLY NO. 69-1890

Ref. No.	Part No.	Description	No. Used
1	69-1930	Cup Assembly	1
2	69-1920	Baffle	1
3	27-7120	Nut	1
4	69-1910	Clamp Assembly	1

Ref. No.	Part No.	Description	No. Used
5	69-1900	Element Assembly	1
†6		Housing	1
*	27-7220	Detergent - Element	1

*Not Illustrated
 †Not Serviceable

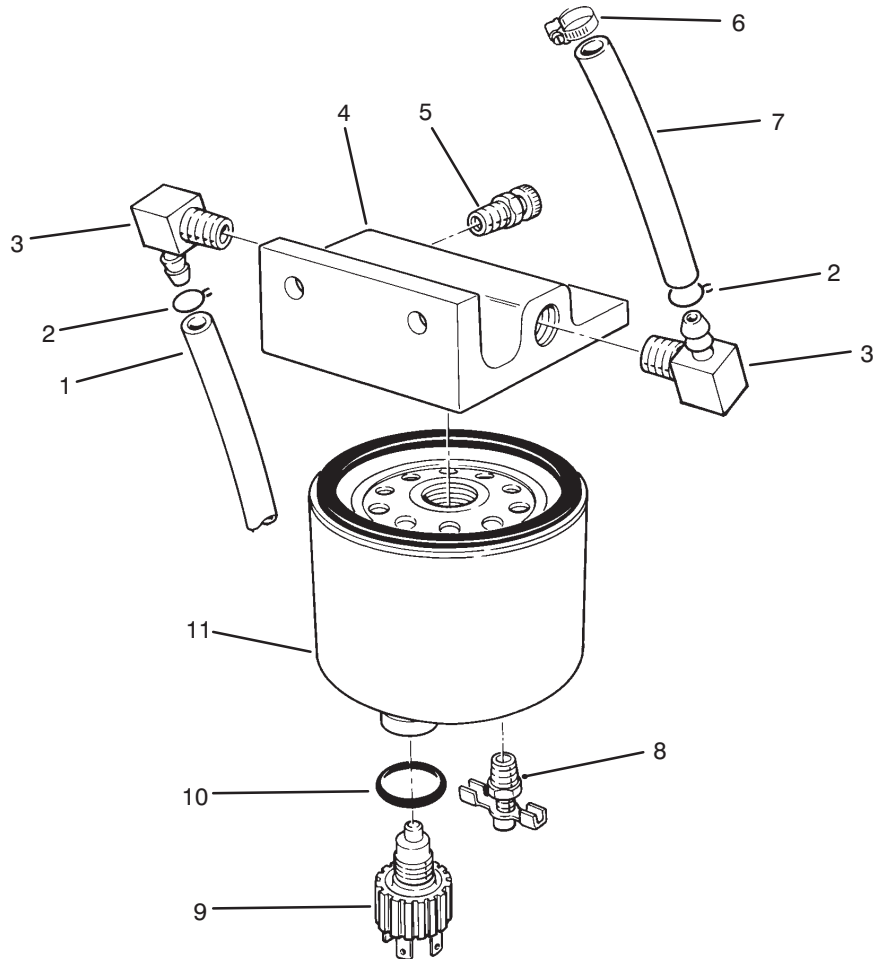

T-0376

FUEL FILTER ASSEMBLY

Ref. No.	Part No.	Description	No. Used	Ref. No.	Part No.	Description	No. Used
1	37-9560	Hose - Fuel	1	8	63-8310	Valve - Drain	1
2	2412-6	Clamp - Hose	2	9	69-1760	Sensor - Water	1
3	353-781	Fitting - Fuel Elbow	2	10	237-154	Seal - O-Ring	1
4	63-8280	Head - Fuel Filter (Incl. Ref. #5)	1	11	69-1770	Element - Spin-On (Incl. Ref. #6)	1
5	63-8290	Vent - Air	1	*	69-1750	Fuel Filter Assembly (Incl. Ref. #4, 5 & 8-11)	1
6	2412-108	Clamp - Hose	1				
7	71-2690	Hose - Fuel	1				

*Not Illustrated

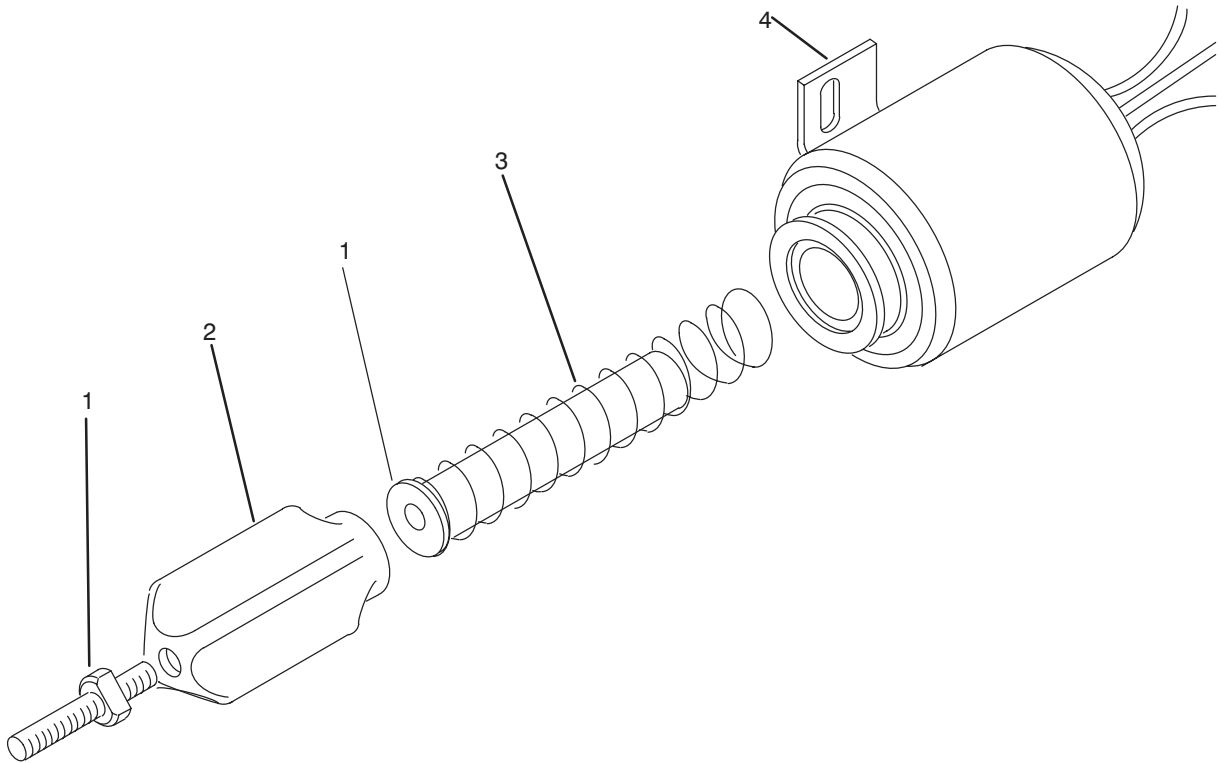

T-1758

SOLENOID VALVE NO. 85-6230

Ref. No.	Part No.	Description	No. Used
1	85-6300	Assembly - Plunger	1
2	85-6290	Boot - Rubber	1
3	85-6280	Spring - Return	1

Ref. No.	Part No.	Description	No. Used
4		Body - Solenoid	1
*	85-6230	Assembly - Solenoid Valve (Incl. Ref. #1-4)	1

*Not Illustrated

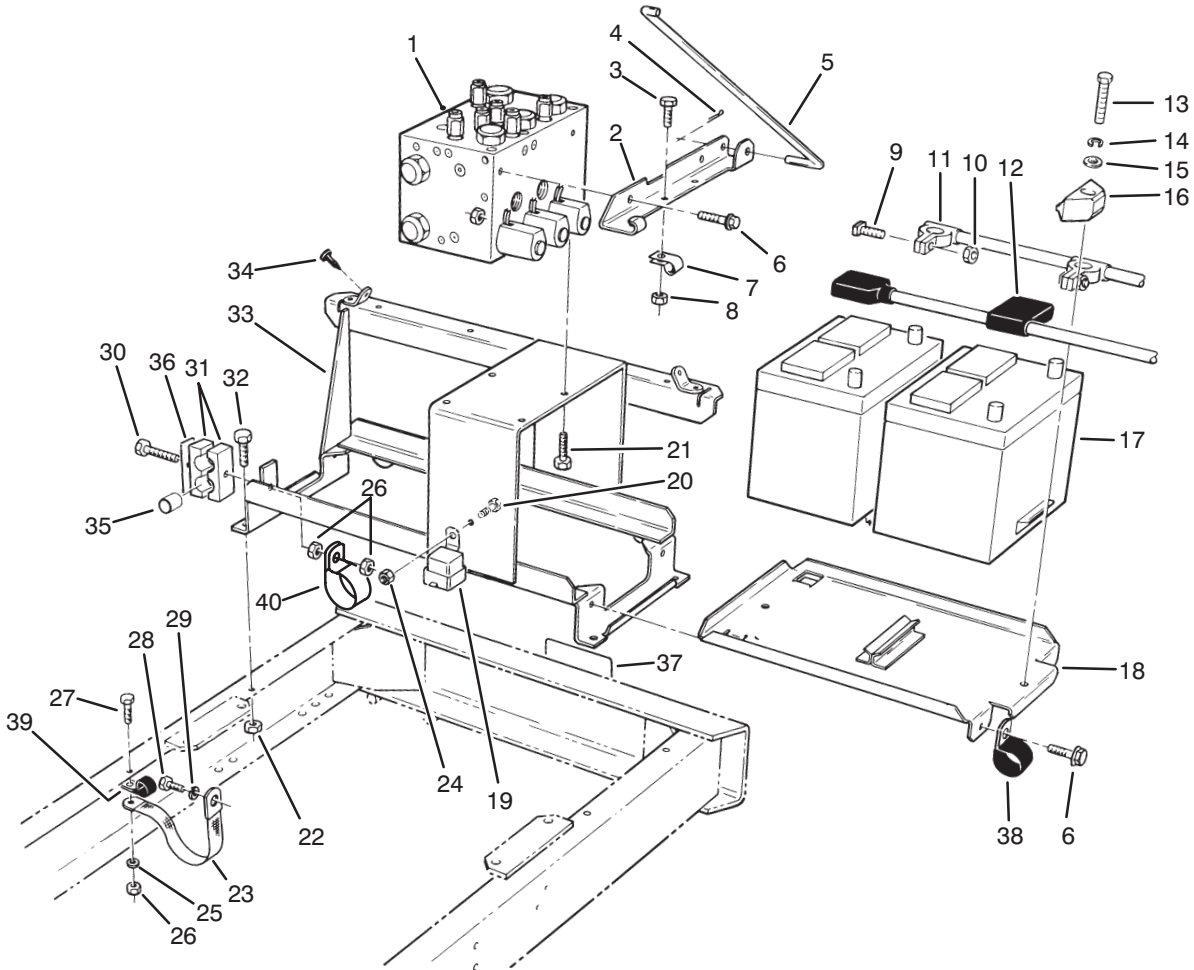

T-0346B

BATTERY FRAME ASSEMBLY

Ref. No.	Part No.	Description	No. Used
1	69-4150	PTO Manifold Assembly	1
2	69-9350	Bracket - Hood Prop Rod	1
3	321-3	Screw - Cap Hex. Hd.	3
4	3272-6	Pin - Cotter	1
5	69-9120	Rod - Hood Prop	1
6	3234-17	Screw - Hex. Flange Hd.	4
7	2412-73	Clamp - R	3
8	32149-2	Nut - Keps	3
†9		Bolt - Clamp	4
†10		Nut - Clamp	4
11	80-0130	Cable - Negative	1
12	92-4997	Cable - Positive	1
13	323-9	Screw - Cap Hex. Hd.	2
14	3253-21	Washer - Lock	2
15	3256-24	Washer - Flat	2
16	66-2490	Hold-Down - Battery	2
‡17		Battery (Type 24, LTV)	2
18	80-0160	Tray - Battery	1
19	63-7590	Relay	1
20	3290-321	Screw - Cap Hex. Hd.	1

Ref. No.	Part No.	Description	No. Used
21	323-4	Screw - Cap Hex. Hd.	4
22	32152-2	Nut - Lock	4
23	18-2770	Strap - Ground	1
24	3296-2	Nut - Flange Lock	1
25	3254-2	Washer - Lock	1
26	32152-1	Nut - Lock	3
27	322-5	Screw - Cap Hex Hd.	1
28	69-0060	Screw - Cap Hex. Hd.	1
29	48-8070	Washer - Lock	1
30	322-11	Screw - Cap Hex. Hd.	1
31	56-7974	Clamp - Hydraulic Lines	2
32	323-6	Screw - Cap Hex. Hd.	4
33	69-8290	Frame - Battery	1
34	237-37	Bumper - Rubber	4
35	23-7250	Spacer	1
36	69-9761	Plate - Clamp	1
37	72-4080	Decal - Danger	1
38	2412-41	Clamp	2
39	2412-39	Clamp	1
40	2412-104	Clamp-R	1

†Not serviceable separately.

‡Obtain Locally

PTO MANIFOLD ASSEMBLY

Ref. No.	Part No.	Description	No. Used	Ref. No.	Part No.	Description	No. Used
1	69-5590	Hose - Hydraulic	2	25	92-3071	Spool - Solenoid Valve (Incl. Ref. # 24, 26-28)	3
†2		Seal - O-Ring	6	†26		Seal - O-Ring	3
†4		Seal - O-Ring	6	†27		Seal - Washer	6
5	69-4170	Valve - Cartridge (600 lbs) (Incl. Ref. #2-4)	3	†28		Seal - O-Ring	6
6	353-989	Plug (Incl. Ref. #7)	1	†29		Manifold - PTO	1
7	237-42	Seal - O-Ring	1	30	237-156	Seal - O-Ring	30
8	69-4180	Valve - Cartridge (3000 lbs) (Incl. Ref. #2-4)	3	31	353-991	Plug (Incl. Ref. #30)	30
9	69-5600	Hose - Hydraulic	1	32	237-79	Seal - O-Ring	4
10	237-58	Seal - O-Ring	8	33	237-78	Seal - O-Ring	1
11	69-6160	Tube - Hydraulic	1	34	353-990	Plug (Incl. Ref. #33)	1
12	340-65	Seal - O-Ring	2	†35		Seal - O-Ring	6
13	340-129	Fitting - Hydraulic Elbow (Incl. Ref. #12 & 14)	1	†36		Seal - O-Ring	6
14	237-146	Seal - O-Ring	1	†37		Seal - O-Ring	6
15	340-142	Fitting - Hydraulic Elbow (Incl. Ref. #10 & 16)	1	38	69-4200	Valve - Cartridge (75 lbs) (Incl. Ref. #35-37)	3
17	69-5610	Hose - Hydraulic	1	39	353-988	Plug (Incl. Ref. #32)	4
18	340-9	Fitting - Hydraulic Straight (Incl. Ref. #10 & 19)	7	40	69-4190	Valve - Cartridge (20 lbs) (Incl. Ref. #35-37)	3
19	237-81	Seal - O-Ring	8	41	237-78	Seal - O-Ring	2
20	69-6180	Tube - Hydraulic	1	42	353-431	Fitting - Hydraulic 45° (Incl. Ref. #41 & 43)	2
21	69-6170	Tube - Hydraulic	1	44	93-7423	Hose - Diagnostic	2
23	88-9190	Solenoid Coil Assembly	3	45	69-6140	Tube - Hydraulic	1
24	3219-10	Nut - Jam	3	46	69-6150	Tube - Hydraulic	1

†Not serviceable separately.

PTO MANIFOLD ASSEMBLY (Continued)

Ref. No.	Part No.	Description	No. Used
47	69-4220	Plug - Orifice	1
*	69-4230	Cartridge Valve Seal Kit (Incl. Ref. #2 & 4)	6
*	69-4270	Cartridge Valve Seal Kit (Incl. Ref. #35-37)	6

Ref. No.	Part No.	Description	No. Used
*	69-4260	Solenoid Valve Seal Kit (Incl. Ref. #26-28)	3
*	69-4150	PTO Manifold Assembly (Incl. Ref. #2, 4-8, 22-40 & 47)	1

*Not Illustrated

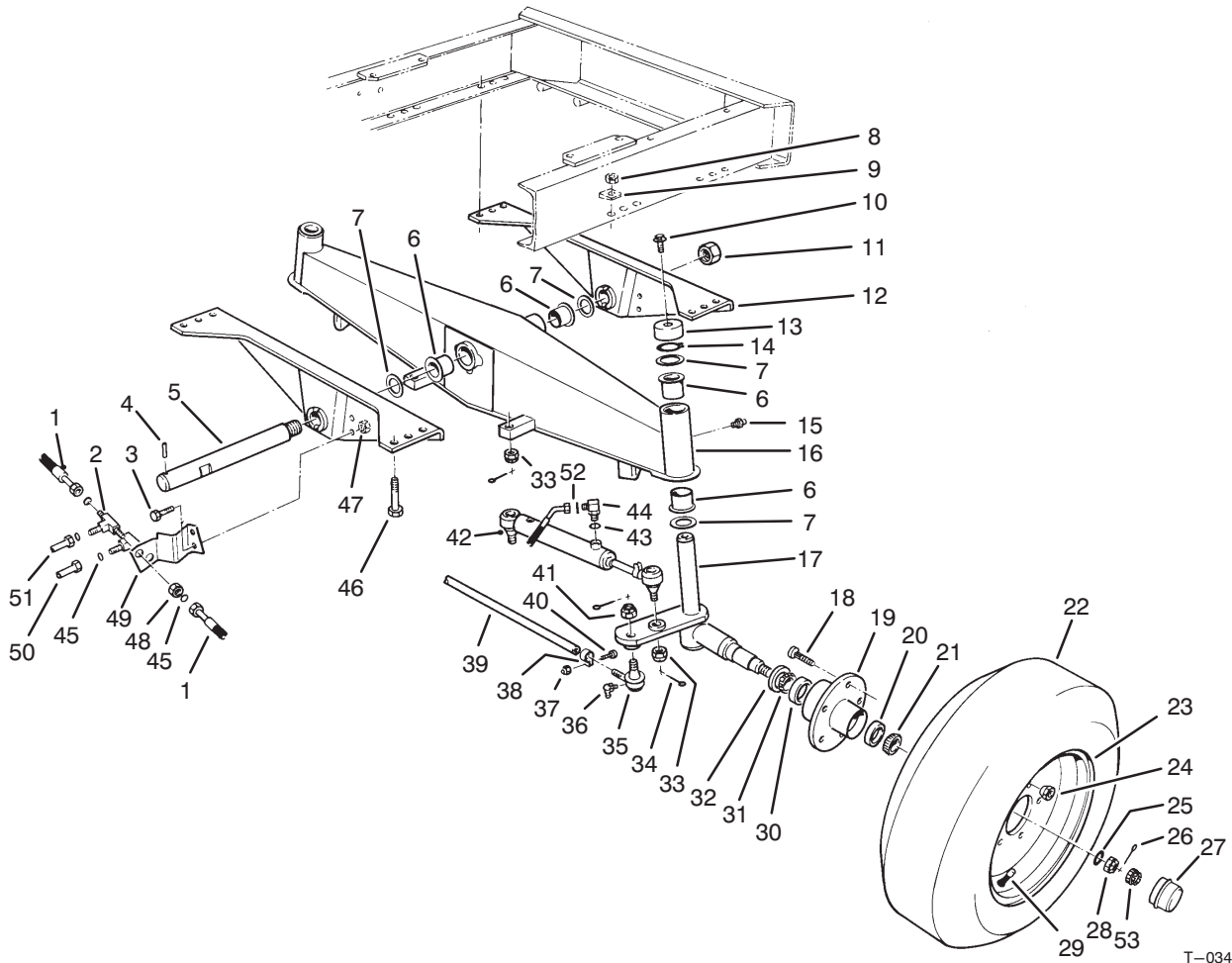

T-0345

REAR AXLE ASSEMBLY

Ref. No.	Part No.	Description	No. Used	Ref. No.	Part No.	Description	No. Used
1	69-5510	Hose - Hydraulic	4	24	23-7270	Nut - Lug	10
2	340-68	Fitting - Hydraulic Bulkhead Tee (Incl. Ref. #45)	2	25	93-0309	Washer	2
3	323-6	Screw - Cap Hex. Hd.	2	26	3272-13	Pin - Cotter	2
4	32121-110	Pin - Roll	1	27	69-2970	Cap - Hub	2
5	71-2590	Shaft - Pivot	1	28	3220-7	Nut - Jam	2
6	69-6470	Bushing - Flange	6	29	232-27	Stem - Valve	2
7	256-304	Washer - Thrust	6	30	254-107	Cup - Bearing Inner	2
8	32128-23	Nut - Lock	12	31	254-106	Cone - Bearing Inner	2
9	3290-216	Washer - Bevel	12	32	69-2980	Seal - Inner	2
10	3234-12	Screw - Hex. Flange Hd.	2	33	32136-13	Nut - Castle	4
11	3296-68	Nut - Lock	1	34	3272-12	Pin - Cotter	6
12	69-7960	Support - Axle	2	35	2116-4	Joint - Ball R.H.	1
13	69-8890	Cap - Spindle	2	*	2116-3	Joint - Ball L.H.	1
14	32151-10	Ring - Retaining	2	36	302-33	Fitting - Grease	2
15	302-5	Fitting - Grease	3	†37		Nut - Lock	2
16	69-7420	Axle - Rear		38	2412-7	Clamp Assembly (Incl. Ref. #37 & 40)	2
17	93-0311	Spindle - Wheel L.H.	1	39	3-3710	Tie Rod Assembly (Incl. Ref. #35-41)	1
*	93-0310	Spindle - Wheel R.H.	1	†40		Screw - Cap Hex. Hd.	2
18	69-2990	Screw - Drive	10	41	32136-2	Nut - Castle	2
19	69-2960	Hub - Rear Wheel (Incl. Ref. #18, 20 & 30)	2	42	69-1960	Hydraulic Cylinder Assembly	2
20	254-72	Cup - Bearing Outer	2	43	237-78	Seal - O-Ring	4
21	254-92	Cone - Bearing Outer	2	44	340-132	Fitting - Hydraulic Elbow (Incl. Ref. #43 & 52)	4
22	69-9880	Tire	2	45	237-22	Seal - O-Ring	6
23	217-116	Rim	2	46	325-6	Screw - Cap Hex. Hd.	12

*Not Illustrated

†Not serviceable separately.

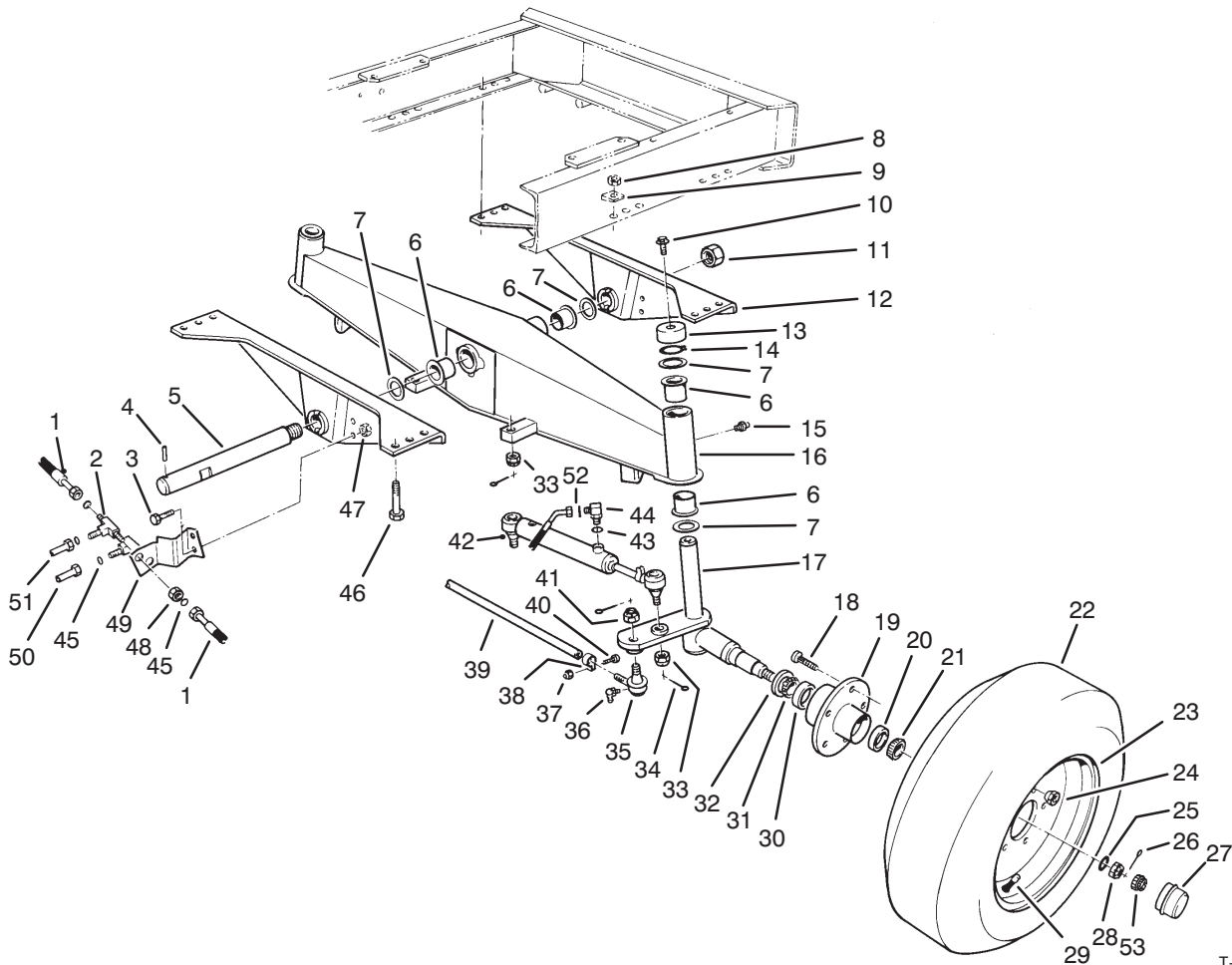

T-0345

REAR AXLE ASSEMBLY (Continued)

Ref. No.	Part No.	Description	No. Used
47	32152-2	Nut - Lock	2
48	340-70	Nut - Bulkhead	2
49	69-9400	Bracket - Hose Support	1
50	69-6010	Tube - Hydraulic	1

Ref. No.	Part No.	Description	No. Used
51	69-6020	Tube - Hydraulic	1
52	237-21	Seal - O-Ring	4
53	93-0307	Nut - Retainer	2

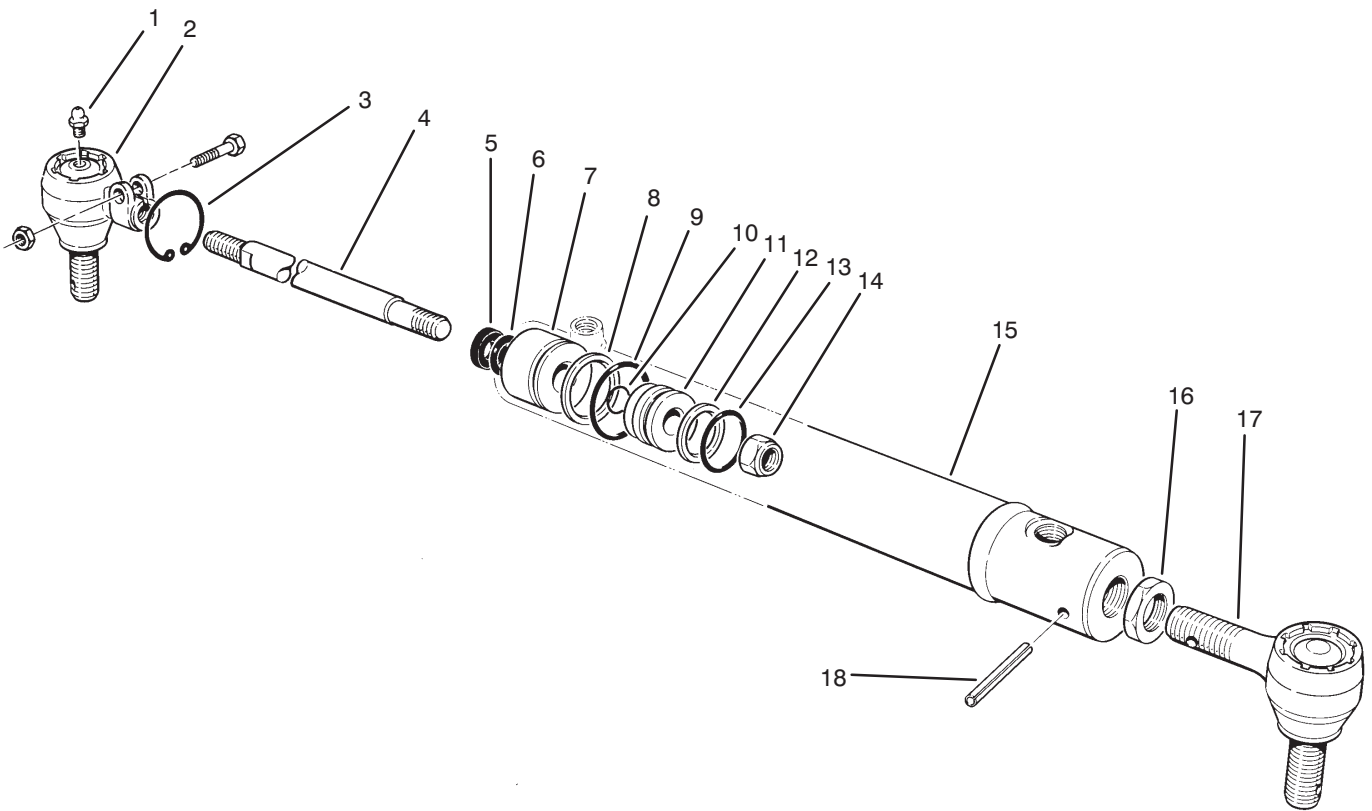

T-0378

HYDRAULIC CYLINDER ASSEMBLY NO. 69-1960

Ref. No.	Part No.	Description	No. Used
1	302-5	Fitting - Grease	1
2	69-9810	Joint - Ball	1
3		Ring - Retaining	1
4	69-2020	Rod - Piston	1
5		Wiper - Rod	1
6		Seal - U-Cup	1
7	69-2030	Ring - Head	1
8		Ring - Back-Up	1
9		Seal - O-Ring	1
10		Seal - O-Ring	1
11	69-2000	Piston	1

Ref. No.	Part No.	Description	No. Used
12		Ring - Piston	1
13		Seal - O-Ring	1
14	69-1990	Nut - Lock	1
15		Barrel - Cylinder	1
16	69-1980	Nut - Jam	1
17	69-1970	Joint - Ball	1
18	32121-34	Pin - Roll	1
*	92-1792	Repair Kit (Incl. Ref. #3, 5, 6, 8-10 & 12-13)	1
*	69-1960	Steering Cylinder (Complete) (Incl. Ref. #3-18)	2

*Not Illustrated

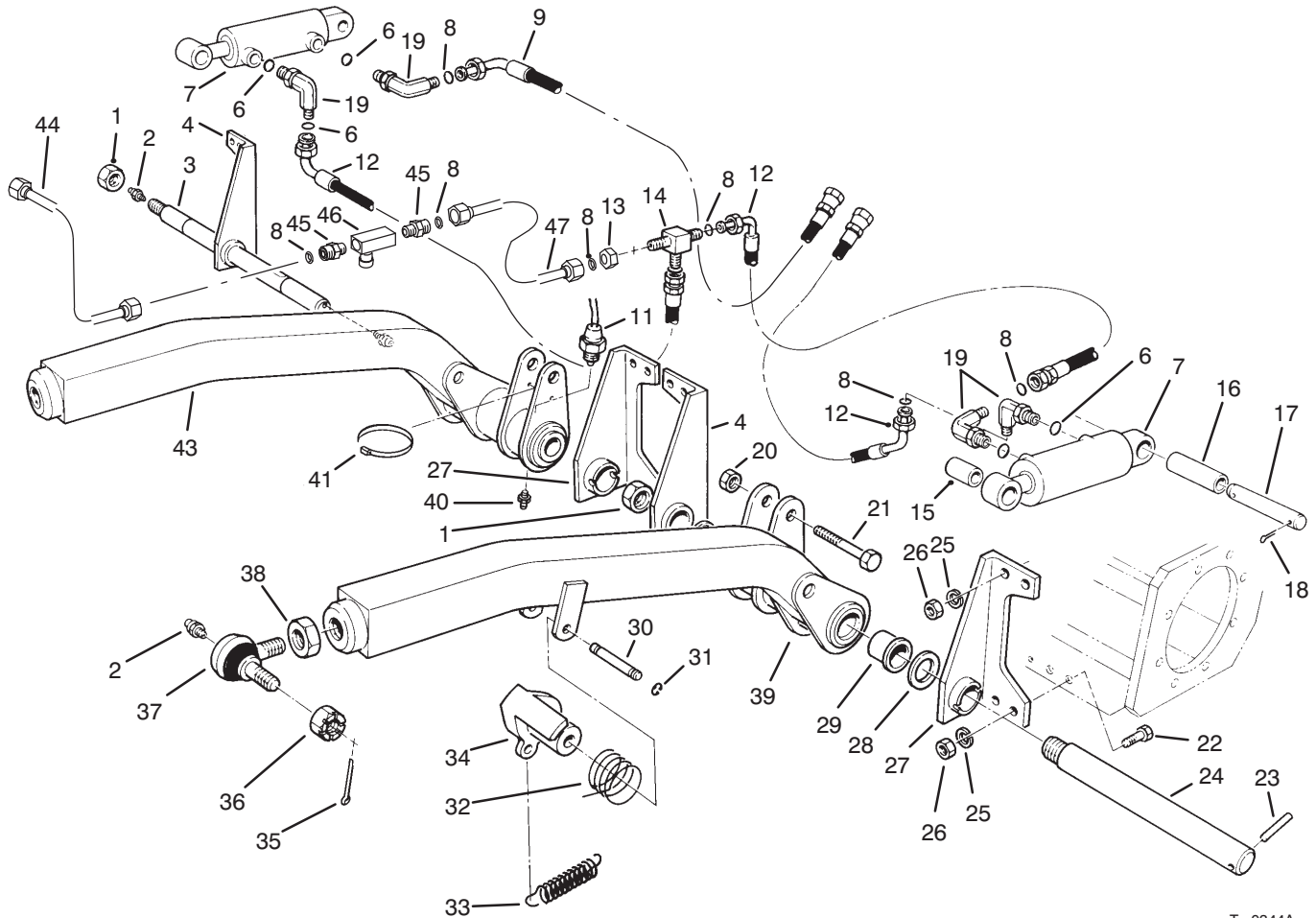

T-0344A

FRONT LIFT ARM ASSEMBLY

Ref. No.	Part No.	Description	No. Used
1	3296-68	Nut - Lock	2
2	302-2	Fitting - Grease	4
3	71-2570	Shaft - Pivot	1
4	69-7940	Support - Lift Arm R.H.	2
6	237-42	Seal - O-Ring	4
7	92-4971	Hydraulic Cylinder Assembly	2
8	237-22	Seal - O-Ring	9
9	69-8440	Hose - Hydraulic	1
11	72-4310	Switch - Ball	1
12	69-5440	Hose - Hydraulic	3
13	340-70	Nut - Bulkhead	1
14	340-68	Fitting - Hydraulic Bulk. Tee (Incl. Ref. #8)	1
15	69-9190	Tube - Cylinder Bushing	2
16	20-4360	Tube - Spacer	2
17	69-9180	Pin - Cylinder	2
18	3272-23	Pin - Cotter	4
19	340-77	Fitting - Hydraulic Elbow (Incl. Ref. #6 & 8)	4
20	32153-6	Nut - Lock	2
21	328-10	Screw - Cap Hex. Hd.	2
22	325-6	Screw - Cap Hex. Hd.	12
23	32121-110	Pin - Roll	2
24	71-2590	Shaft - Pivot	1
25	3253-7	Washer - Lock	16

Ref. No.	Part No.	Description	No. Used
26	3217-9	Nut - Hex.	16
27	69-7920	Support - Lift Arm L.H.	2
28	256-304	Washer - Thrust	2
29	69-6470	Bushing - Flange	4
30	92-4806	Pin - Latch	1
31	32120-47	Ring - Retaining	2
32	69-8470	Spring - Torsion	1
33	76-1670	Spring - Extension	1
34	69-1540	Pivot - Spring	1
35	3272-12	Pin - Cotter	2
36	32136-2	Nut - Slotted	2
37	86-8100	Joint - Ball (Incl. Ref. #2 & 36)	2
38	21-3000	Nut - Jam	2
39	69-9580	Front Lift Arm Assy. L.H. (Incl. Ref. #29 & 40)	1
40	302-5	Fitting - Grease	2
41	3290-378	Tie - Cable	1
43	69-9570	Front Lift Arm Assy. R.H. (Incl. Ref. #29 & 40)	1
44	93-7426	Tube - Hydraulic	1
45	340-57	Fitting - Hydraulic Straight (Incl. Ref. #8)	2
46	93-1397	Valve - Flow Control	1
47	93-7427	Tube - Hydraulic	1

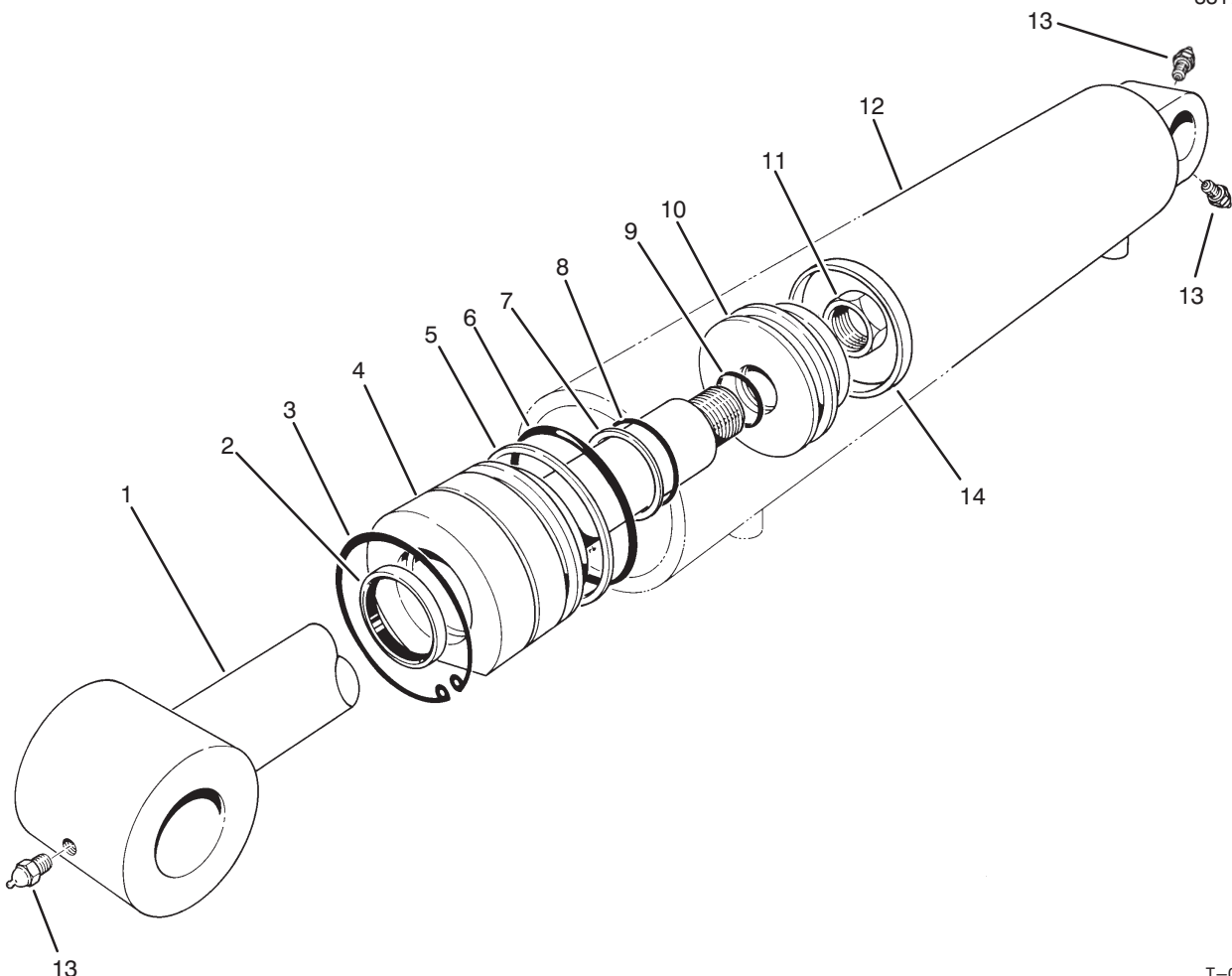

T-0380A

HYDRAULIC CYLINDER ASSEMBLY NO. 92-4971

Ref. No.	Part No.	Description	No. Used
1	69-2580	Shaft w/clevis	1
†2		Seal - Dust	1
3	61-4990	Ring - Retaining	1
4	69-2570	Head	1
†5		Ring - Back-Up	1
†6		Seal - O-Ring	1
†7		Ring - Back-Up	1
†8		Seal - O-Ring	1

Ref. No.	Part No.	Description	No. Used
†9		Uni-Ring	1
10	60-9770	Piston	1
11	60-9760	Nut - Lock	1
†12		Barrel	1
13	302-5	Fitting - Grease	3
14		Seal - Uni-Ring	1
*	86-7350	Seal Repair Kit (Incl. Ref. #2 & 5-9)	1

*Not Illustrated

†Not serviceable separately.

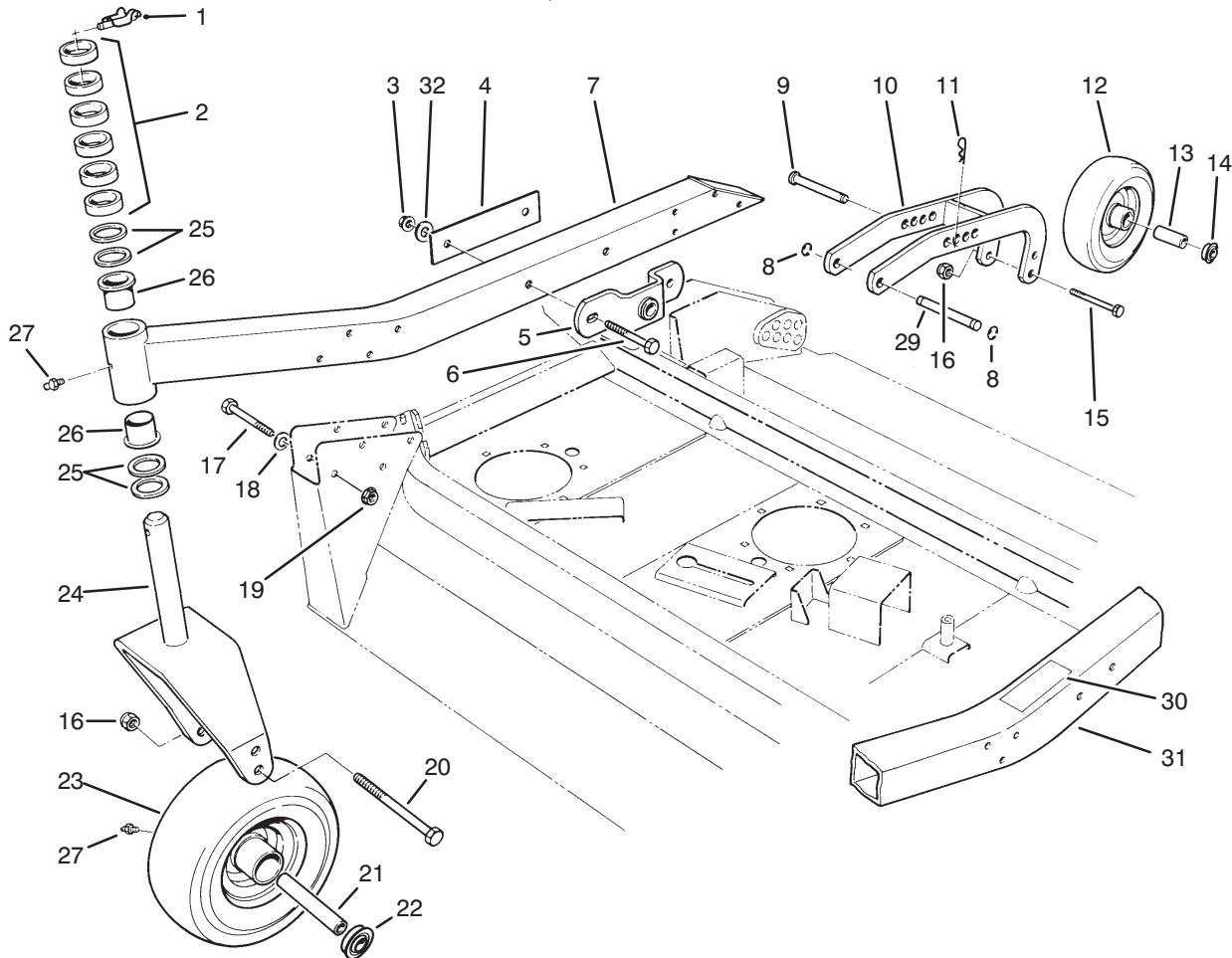

T-0362B

CENTER DECK MODEL NO. 30592 CARRIER FRAME ASSEMBLY

Ref. No.	Part No.	Description	No. Used
1	3290-384	Pin - Lynch	2
2	69-1510	Spacer - Caster	12
3	32128-23	Nut - Flange Lock	4
4	69-8790	Plate - Reinforcing	2
5	69-7290	Mount - Ball Joint	2
6	325-15	Screw - Cap Hex. Hd.	4
7	69-8860	Arm - Castor R.H. (Incl. Ref. #26-27)	1
8	32151-48	Ring - Retaining	4
9	283-70	Pin - Hitch (Incl. Ref. #11)	2
10	75-9790	Arm - Pivot	2
11	3290-343	Pin - Cotter Hair	2
12	93-4240	10" Wheel - Pneumatic (Incl. Ref. #13-14)	2
13	93-4241	Spacer	2
14	93-4237	Bearing	4
15	327-24	Screw Cap Hex. Hd.	2
16	3296-53	Nut - Lock	4

Ref. No.	Part No.	Description	No. Used
17	323-15	Screw - Cap Hex. Hd.	16
18	5-0838	Washer - Flat	16
19	32128-43	Nut - Lock	16
20	327-25	Screw - Cap Hex. Hd.	2
21	251-333	Spacer - Bearing	2
22	251-321	Bearing - Castor	4
23	92-2362	Castor Wheel Assembly (Incl. Ref. #21-22, & 27)	2
24	69-6270	Fork - Castor	2
25	69-6860	Washer - Castor	8
26	69-6470	Bushing - Flange	4
27	302-5	Fitting - Grease	4
29	69-9260	Pin - Clevis	2
30	69-0880	Decal - Torque	1
31	13-5069	Arm - Castor L.H. (Incl. Ref. #26-27, & 30)	1
32	30-8770	Washer - Flat	4

CENTER DECK MODEL NO. 30592

Ref. No.	Part No.	Description	No. Used
1	76-2760	Hydraulic Hose Assembly	1
2	76-2750	Hydraulic Hose Assembly	1
3	237-58	Seal - O-Ring	2
4	340-142	Fitting - Hydraulic Elbow (Incl. Ref #3 & 5)	2
5	237-81	Seal - O-Ring	2
6	76-2770	Hydraulic Hose Assembly	1
7	237-22	Seal - O-Ring	1
8	69-4320	Fitting - Hydraulic 90° (Incl. Ref. #7 & 9)	1
9	237-42	Seal O-Ring	1
10	32128-21	Nut - Flange Lock	6
11	93-4363	Motor - Hydraulic	1
12	3231-28	Bolt - Carriage	2
13	19-1470	Bolt - Shoulder	4
14	69-6960	Spacer - Idler	4
15	63-1540	Pulley - Idler	3
16	325-7	Screw - Cap Hex. Hd.	1
17	69-9290	Pad - Bumper	2
18	32108-103	Screw - Flat Hd.	4
19	32128 -20	Nut - Lock	4
20	302-2	Fitting - Grease	1
21	32120-72	Ring - Retaining	1
22	256-188	Bushing - Sleeve	1
23	69-6610	Arm - Idler (Incl. Ref. #22)	1
24	325-8	Screw - Cap Hex. Hd.	1
25	69-5430	Pulley-Idler	1

Ref. No.	Part No.	Description	No. Used
26	69-6970	Spacer - Idler	1
27	32105-1	Screw - Machine	8
28	256-117	Bushing - Flange	4
29	3269-25	Rivet - Pop	8
30	69-6780	Cover - Center Left	1
31	69-6870	Plate - Magnet	4
32	69-6260	Magnet - Cover	4
33	302-5	Fitting - Grease	4
34	3296-2	Nut - Lock	8
35	32128-23	Nut - Flange Lock	4
36	76-1670	Spring - Extension	1
37	3217-9	Nut - Jam	2
38	69-6550	Arm - Tension	1
39	82-2560	Decal - Belt Routing	1
40	43-8480	Decal - Danger	1
41	13-4969	Deck - Center (Incl. Ref. #20, 28, 33, 39, 40 & 57)	1
42	3233-27	Bolt - Carriage	1
43	69-6490	Plate - Tension	1
44	77-2830	Rod - Spring	1
45	3272-7	Pin - Cotter	1
47	69-6890	Spacer - Spring	1
48	86-7480	Spring - Compression	1
49		Screw - Set	2
50	23-1640	Bushing - Taper Lock (Incl. Ref. #49)	1

CENTER DECK MODEL NO. 30592 (Continued)

Ref. No.	Part No.	Description	No. Used
51	63-0660	Pulley - Drive	1
52	69-6390	Plate - Gearbox	1
53	3234-12	Screw - Hex. Flange Hd.	4
54	69-6790	Cover - Center Right	1
56	71-4260	Decal - H.O.C.	1
57	69-0820	Decal - H.O.C.	1

Ref. No.	Part No.	Description	No. Used
58	3-6498	Washer - Flat	1
59	3233-30	Bolt - Carriage	1
60	66-1340	Decal - Danger	1
61	93-9324	Pivot - Idler	1
*	93-8457	Hex.-Belt - Deck Drive	1
*	3290-378	Tie - Cable	2

*Not Illustrated

T-0366A

CENTER DECK MODEL NO. 30592 LEFT WING ASSEMBLY

Ref. No.	Part No.	Description	No. Used
1	3269-25	Rivet - Pop	4
2	3296-2	Nut - Lock	6
3	40-9520	Spacer - Split	2
4	40-0330	Cushion - Rubber	1
5	3250-27	Screw - Truss Hd.	2
6	323-6	Screw - Cap Hex. Hd.	3
7	69-6730	Skid	1
8	32128-23	Nut - Flange Lock	3
9	3233-9	Bolt - Carriage	3
10	32128-21	Nut - Flange Lock	6
11	32105-1	Screw - Machine	4
12	13-4989	Deck - Left Wing (Incl. Ref. #23-25)	1
13	69-6640	Hinge - Left Front	1
14	69-6900	Shaft - Hinge	1
15	69-6260	Magnet - Cover	2
16	256-305	Washer - Thrust	2

Ref. No.	Part No.	Description	No. Used
17	69-6670	Hinge - Left Rear	1
18	32121-6	Pin - Roll	2
19	69-6910	Bracket - Support	1
20	3231-25	Bolt - Carriage	2
21	69-6870	Plate - Magnet	2
22	69-6850	Cover - Left Wing	1
23	66-1340	Decal - Danger	1
24	43-8480	Decal - Danger	1
25	67-5360	Decal - Danger	1
26	3256-69	Washer	2
27	82-4910	Roller	1
28	32121-4	Pin - Roll	2
29	88-9270	Bracket - Roller LH	1
30	5-0838	Washer - Flat	3
31	323-7	Screw - Cap Hex. Hd.	3
*	76-2060	V-Belt	1
*	42-6200	Shim - Cushion	A/R

*Not Illustrated

CENTER DECK MODEL NO. 30592 RIGHT WING ASSY.

Ref. No.	Part No.	Description	No. Used
1	3269-25	Rivet - Pop	4
2	69-6840	Cover - Right Wing	1
3	69-6870	Plate - Magnet	2
4	302-2	Fitting - Grease	1
5	32120-72	Ring - Retaining	1
6	256-188	Bushing - Sleeve	1
7	69-5430	Pulley - Idler	1
8	325-8	Screw - Cap Hex. Hd.	1
9	3231-25	Bolt - Carriage	2
10	3296-2	Nut - Lock	6
11	69-6910	Bracket - Support	1
12	40-9520	Spacer - Split	2
13	40-0330	Cushion - Rubber	1
14	3250-27	Screw - Truss Hd.	2
15	69-6260	Magnet - Cover	2
16	32105-1	Screw - Machine	4
17	69-6970	Spacer - Idler	1
18	13-4979	Right Wing Deck Assembly (Incl. Ref. #4, 32 & 33)	1
19	323-6	Screw - Cap Hex. Hd.	3
20	69-6900	Shaft - Hinge	1
21	32121-6	Pin - Roll	2
22	32128-21	Nut - Flange Lock	6

Ref. No.	Part No.	Description	No. Used
23	69-6710	Hinge - Right Rear	1
24	256-305	Washer - Thrust	2
25	76-1670	Spring - Extension	1
26	32128-23	Nut - Flange Lock	4
27	69-6610	Idler Arm Assembly (Incl. Ref. #6)	1
28	69-6690	Hinge - Right Front	1
29	69-6730	Skid	1
30	3233-9	Bolt - Carriage	3
31	67-5360	Decal - Danger	1
32	43-8480	Decal - Danger	1
33	66-1340	Decal - Danger	1
34	3-6498	Washer	1
35	3256-69	Washer	2
36	82-4910	Roller	1
37	32121-4	Pin - Roll	2
38	88-9260	Bracket - Roller RH	1
39	323-7	Screw - Cap Hex. Hd.	3
40	5-0838	Washer - Flat	3
41	93-9324	Pivot - Idler	1
*	76-2060	V-Belt	1
*	42-6200	Shim - Cushion	A/R

*Not Illustrated

WING DECK LIFT ASSEMBLY

Ref. No.	Part No.	Description	No. Used	Ref. No.	Part No.	Description	No. Used
1	322-11	Screw - Cap Hex. Hd.	1	22	69-6180	Tube - Hydraulic L.H.	1
2	56-7974	Clamp Half - Hydraulic Line	2			(Incl. Ref. #20)	1
3	32152-1	Nut - Lock	5	*	69-6150	Tube - Hydraulic R.H.	1
4	32153-6	Nut - Lock	22			(Incl. Ref. #20)	1
5	32152-2	Nut - Lock	6	23	32152-4	Nut Lock	3
6	69-6170	Tube - Hydraulic L.H.	1	24	3272-33	Pin - Cotter	2
		(Incl. Ref. #20)	1	25	32108-103	Screw - Machine Flat Hd.	4
*	69-6140	Tube - Hydraulic R.H.	1	26	71-2580	Shaft - Lift Arm Pivot	2
		(Incl. Ref. # 20)	1	27	32121-110	Pin - Roll	2
7	69-9450	Bracket - Wing Hose L.H.	1	28	328-26	Screw - Cap Hex. Hd.	12
*	69-9460	Bracket - Wing Hose R.H.	1	29	256-304	Washer - Thrust	4
8	240-3	Grommet	4	30	69-6470	Bushing - Flange	4
9	69-9000	Spacer	4	31	302-2	Fitting - Grease	4
10	69-9010	Washer	8	32	72-4310	Switch - Lift	2
11	340-74	Nut - Bulkhead	4	33	92-8664	Lift Arm Assembly L.H.	1
12	323-6	Screw - Cap Hex. Hd.	4			(Incl. Ref. #30-31)	1
13	69-9761	Plate - Cover	1	*	92-8665	Lift Arm Assembly R.H.	1
15	340-70	Nut - Bulkhead	10			(Incl. Ref. #30-31)	1
16	69-8940	Washer	20	34	69-9300	Cushion - Rubber	2
17	69-8970	Spacer	10	35	3296-68	Nut Lock	2
18	240-4	Grommet	10	36	328-8	Screw - Cap Hex. Hd.	4
19	237-22	Seal - O-Ring	14	37	328-8	Screw - Cap Hex. Hd.	2
20	237-65	Seal - O-Ring	4	38	69-9190	Bushing - Cylinder	2
21	69-5980	Tube - Hydraulic L.H.	1	39	69-5490	Hose - Cylinder	4
		(Incl. Ref. #19)	1	40	3256-56	Washer - Flat	3
*	69-5970	Tube - Hydraulic R.H.	1	41	340-77	Fitting - Hydraulic Elbow	4
		(Incl. Ref #19)	1			(Incl. Ref. #19 & 42)	4

*Not Illustrated

WING DECK LIFT ASSEMBLY (Continued)

Ref. No.	Part No.	Description	No. Used
42	237-42	Seal - O-Ring	4
43	74-2170	Cylinder - Lift	2
44	323-15	Screw - Cap Hex. Hd.	2
45	74-2680	Bracket - Bulkhead	1
46	69-6030	Tube - Hydraulic (Incl. Ref. #19)	1
47	69-6060	Tube - Hydraulic (Incl. Ref. #19)	1
48	69-6070	Tube - Hydraulic (Incl. Ref. #19)	1
49	69-6000	Tube - Hydraulic (Incl. Ref. #19)	1
50	69-6040	Tube - Hydraulic (Incl. Ref. #19)	1
51	69-6050	Tube - Hydraulic (Incl. Ref. #19)	1

Ref. No.	Part No.	Description	No. Used
52	69-6080	Tube - Hydraulic (Incl. Ref. #19)	1
53	69-5990	Tube - Hydraulic (Incl. Ref. #19)	1
54	69-4400	Carrier - Wing Deck	1
55	69-1580	Anchor - Latch L.H.	1
*	69-1600	Anchor - Latch R.H.	1
56	321-9	Screw - Cap Hex. Hd.	3
57	56-7973	Clamp Half - Hydraulic Line	6
58	328-24	Screw - Cap Hex. Hd.	4
59	39-7650	Plate - Cover	2
60	32144-11	Screw - Thread Forming	4
61	93-9922	Spacer	2
*	3290-378	Tie - Cable	3

*Not Illustrated

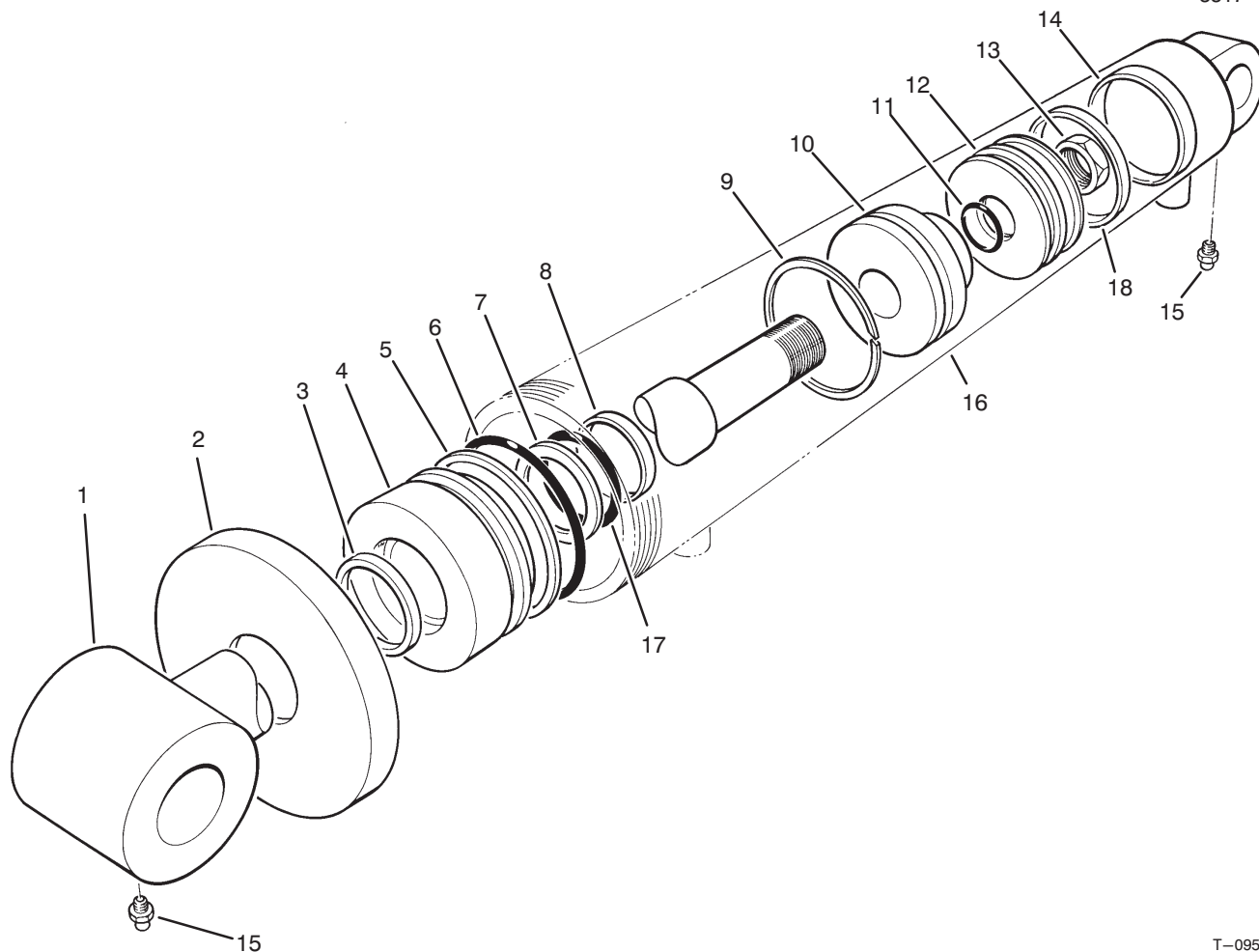

T-0959A

HYDRAULIC CYLINDER ASSEMBLY NO. 74-2170

Ref. No.	Part No.	Description	No. Used
1	74-2230	Shaft/Clevis	1
2	74-2220	Collar	1
†3		Seal - Dust	1
4	74-2200	Head	1
†5		Ring - Back-Up	1
†6		Seal - O-Ring	1
†7		Ring - Back-Up	1
†8		Ring - Wear	1
9	74-2180	Ring - Steel	1
10	74-2190	Cushion	1
†11		Uni-Ring	1

Ref. No.	Part No.	Description	No. Used
12	74-2210	Piston	1
13	60-9760	Nut - Lock	1
†14		Ring - Wear	1
15	302-5	Fitting - Grease	2
†16		Barrel/Clevis	1
†17		Seal - O-Ring	1
18		Seal - Uni-Ring	1
*	86-7350	Seal Repair Kit (Incl. Ref. #3, 5-8, 11, 14 & 17)	1

*Not Illustrated

†Not serviceable separately.

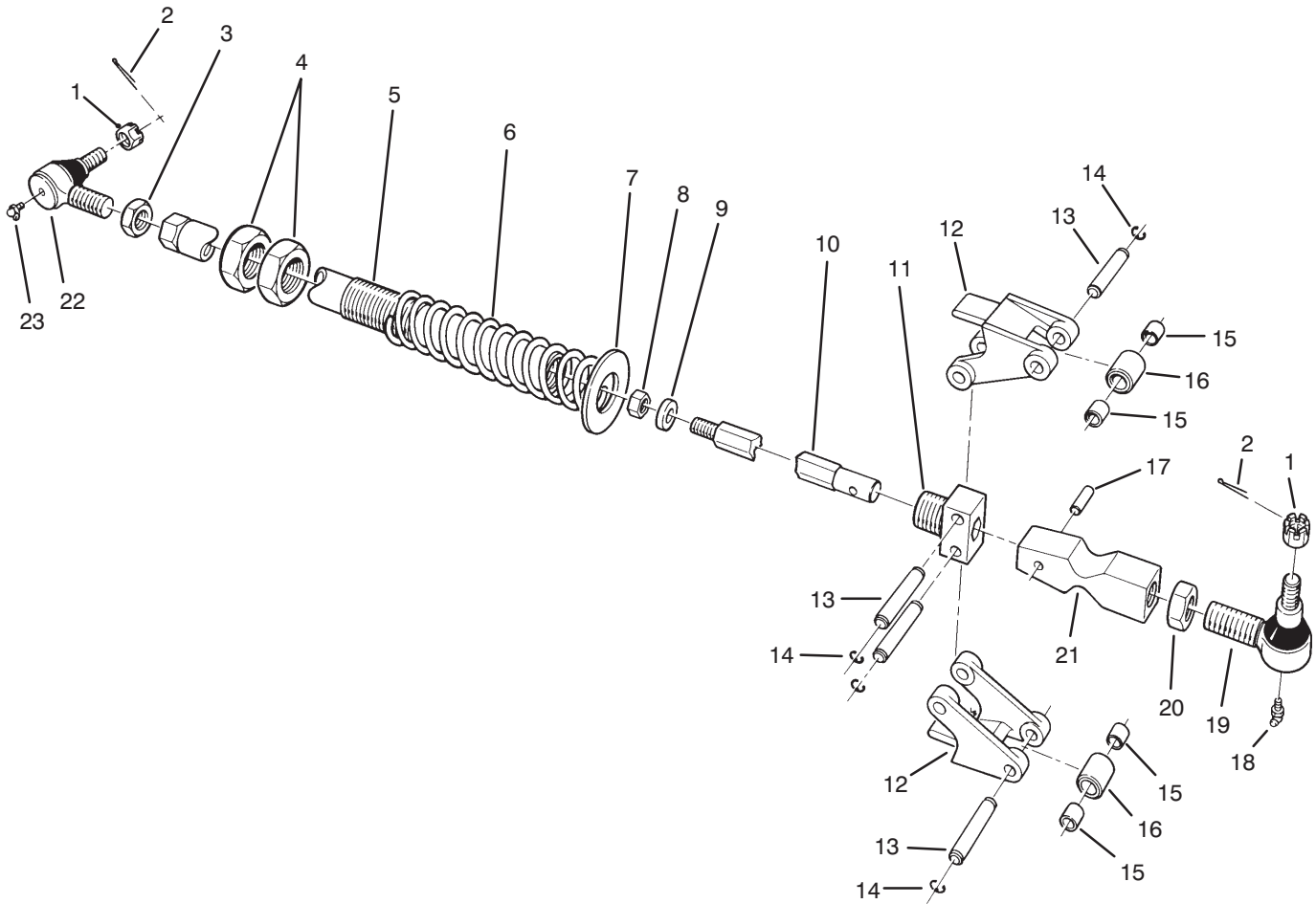

T-0369

WING DECK LATCH ASSEMBLY

Ref. No.	Part No.	Description	No. Used
1	32136-2	Nut - Castle	4
2	3272-12	Pin - Cotter	4
3	21-3001	Nut - Jam L.H. Thread	2
4	3220-22	Nut - Jam	4
5	69-7210	Tube - Latch	2
6	69-8480	Spring - Compression	2
7	69-9100	Washer - Latch	2
8	3296-41	Nut - Lock	2
9	71-2550	Washer - Latch Shaft	2
10	69-9680	Shaft - Latch	2
11	92-4804	Block - Latch Pivot	2
12	69-1630	Arm - Latch Pivot	4
13	92-4806	Pin - Latch	8

Ref. No.	Part No.	Description	No. Used
14	32120-47	Ring - Retaining	16
15	256-172	Bearing - Sleeve	8
16	92-4094	Roller - Latch	4
17	32121-49	Pin - Roll	2
18	302-5	Fitting - Grease	2
19	86-8100	Joint - Ball (Incl. Ref. #1 & 18)	2
20	21-3000	Nut - Jam	2
21	92-4805	Cam - Spring Trip	2
22	86-8101	Joint - Ball (Incl. Ref. #1 & 23)	2
23	302-40	Fitting - Grease	2

WING DECK LIFT ARM ASSEMBLY

Ref. No.	Part No.	Description	No. Used
1	32152-4	Nut - Lock	4
2	74-2710	Clamp Half - Hydraulic Line	4
3	321-15	Screw - Cap Hex. Hd.	4
4	302-2	Fitting - Grease	4
5	69-6470	Bushing - Flange	8
6	256-304	Washer - Thrust	8
7	32152-1	Nut - Lock	4
8	69-9300	Cushion - Rubber	2
9	32108-103	Screw - Machine Flat Hd.	4
10	93-9942	Arm - Outer Lift L.H. (Incl. Ref. #5)	1
*	93-9941	Arm - Outer Lift R.H. (Incl. Ref. #5)	1
11	71-2600	Tube - Anti - Sway	2
12	3220-7	Nut - Jam	4
13	2411-40	Joint - Ball	4
14	82-7930	Arm - Anti-Sway L.H.	1
*	82-7940	Arm - Anti-Sway R.H.	1
15	256-76	Bushing - Sleeve	4
16	69-9240	Roller - Cam	2

Ref. No.	Part No.	Description	No. Used
17	32121-34	Pin - Roll	2
18	69-9250	Shaft - Roller	2
19	3219-7	Nut - Lock	4
20	3253-9	Washer - Lock	4
21	32151-10	Ring - Retaining	2
22	302-5	Fitting - Grease	2
23	71-2620	Shaft - Lift Arm Elbow	2
24	32121-110	Pin Roll	4
25	93-9926	Lift Arm Assembly L.H. (Incl. Ref. #5)	1
*	93-9925	Lift Arm Assembly R.H. (Incl. Ref. #5)	1
26	3254-2	Washer	4
27	322-3	Screw - HH	4
28	93-9928	Clamp - Hose	2
30	93-9912	Grommet	2
31	74-2730	Tube - Clamp	4
32	74-2750	Retainer - Clamp	2
34	82-7900	Shaft - Arm	2

*Not Illustrated

WING DECK MODEL NO 30591 L.H. & 30593 R.H.

Ref. No.	Part No.	Description	No. Used
1	69-8830	Arm - Inside Castor (Incl. Ref. #16 & 34)	2
2	3290-384	Pin - Lynch	8
3	325-20	Screw - Cap Hex. Hd.	8
4	69-8790	Plate - Reinforcing	2
5	69-9700	Mount - Rubber (Incl. Ref. #6)	8
6		Spacer	8
7	32128-23	Nut - Flange Lock	20
8	32128-45	Nut - Lock	8
9	30-8770	Washer - Flat	8
10	69-7170	Clevis - Deck	2
11	3233-29	Bolt - Carriage	2
12	3233-28	Bolt - Carriage	6
13	302-2	Fitting - Grease	2
14	3296-68	Nut - Lock	2
15	71-2610	Shaft - Deck Pivot	2
16	69-6470	Bushing - Flange	20
17	32121-110	Pin - Roll	2
18	69-6420	Bar - Lift L.H. (Incl. Ref. #16)	1
*	69-6480	Bar - Lift R.H. (Incl. Ref. #16)	1
19	13-5059	Arm - Outside Castor (Incl. Ref. #16, 34 & 38)	2

Ref. No.	Part No.	Description	No. Used
20	13-5009	Deck - Wing L.H. (Incl. Ref. #27, 36, 37 & 39)	1
*	13-4999	Deck - Wing R.H. (Incl. Ref. #27, 36, 37 & 39)	1
21	69-6730	Skid	4
22	3233-9	Bolt - Carriage	12
23	323-15	Screw - Cap Hex. Hd.	32
24	5-0838	Washer - Flat	32
25	32128-43	Nut - Lock	32
26	327-17	Screw Cap Hex. Hd.	8
27	43-8480	Decal - Danger	2
28	93-4241	Spacer	8
29	93-4237	Bearing	16
30	93-4240	10" Wheel - Pneumatic (Incl. Ref. #28, 29)	8
31	3296-53	Nut - Lock	8
32	75-9670	Fork - Castor	8
33	69-6860	Washer - Thrust	28
34	302-5	Fitting - Grease	8
35	69-1510	Spacer - Castor	48
36	69-0890	Decal - Belt Routing L.H.	1
*	69-0900	Decal - Belt Routing R.H.	1
37	66-1340	Decal - Danger	2
38	69-0880	Decal - Torque	2
39	67-5360	Decal - Danger	4
40	256-304	Washer - Thrust	4
41	77-0950	Washer - Castor	8

*Not Illustrated

WING DECK MODEL NO. 30591 L.H. & 30593 R.H. DRIVE ASSEMBLY

Ref. No.	Part No.	Description	No. Used	Ref. No.	Part No.	Description	No. Used
1	69-6800	Cover - Inner L.H.	1	16	69-6810	Cover - Outer L.H.	1
*	69-6820	Cover - Inner R.H.	1	*	69-6830	Cover - Outer R.H.	1
2	3234-12	Screw - Hex. Washer Hd.	8	17	3269-25	Rivet - Pop	16
3	69-6360	Plate - Motor Mounting L.H.	1	18	69-6870	Plate - Magnet	8
*	69-6340	Plate - Motor Mounting R.H.	1	19	3296-2	Nut - Lock	16
4	32128-21	Nut - Flange Lock	12	20	69-6260	Magnet - Cover	8
5	237-81	Seal - O-Ring	4	21	32105-1	Screw - Pan Hd.	16
6	340-8	Fitting - Hydraulic Straight (Incl. Ref. #5 & 7)	4	22	3233-30	Bolt - Carriage	6
7	237-65	Seal - O-Ring	4	23	69-6960	Spacer - Idler	6
8	93-9918	Asm. - Hose, Hydraulic	2	24	63-1540	Pulley - Idler	6
9	93-9917	Asm. - Hose, Hydraulic	2	25	32128-23	Nut - Flange Lock	6
10	237-22	Seal - O-Ring	2	26		Screw - Set	4
11	340-2	Fitting - Hydraulic Straight (Incl. Ref. # 10 & 12)	2	27	3231-28	Bolt - Carriage	4
12	237-42	Seal - O-Ring	2	28	71-4260	Decal - H.O.C.	2
13	93-4363	Motor - Hydraulic	2	29	93-9919	Asm. - Hose, Hydraulic	2
14	63-0660	Pulley - Wing Deck Drive	2	*	76-2060	V-Belt	6
15	23-1640	Bushing - Taper Lock (Incl. Ref. #26)	2	*	3290-378	Tie - Cable	24

*Not Illustrated

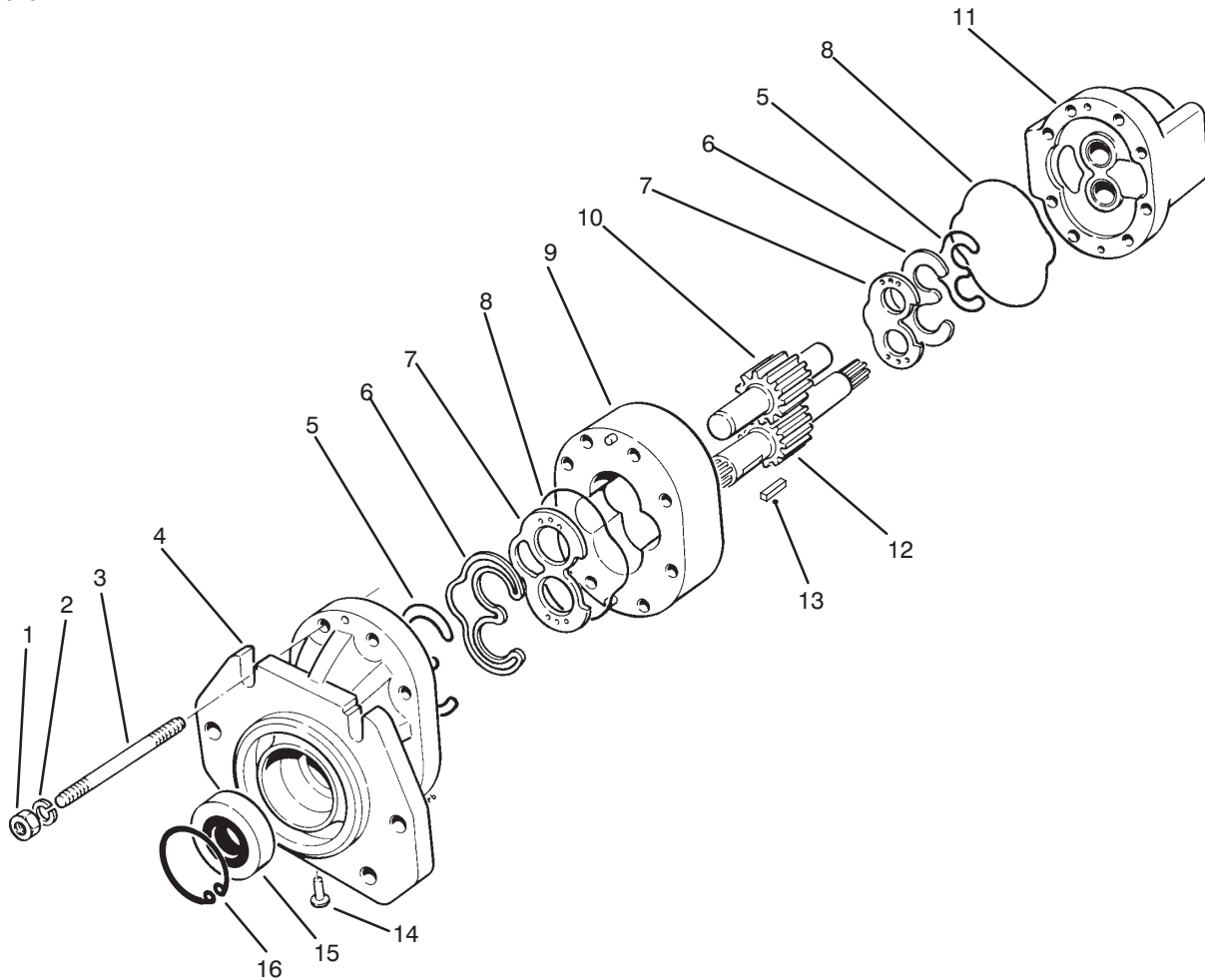

T-1972A

HYDRAULIC MOTOR ASSEMBLY NO. 93-4363

Ref. No.	Part No.	Description	No. Used
1	59-7580	Nut	8
2	59-7590	Washer - Lock	8
3	59-7970	Stud	8
4	93-7634	Cover - Front	1
5		Seal - Gland	2
6		Retainer - Seal	2
7	69-2070	Plate - Flex	2
8		O-Ring, Square	2
9	93-7640	Section - Center	1

Ref. No.	Part No.	Description	No. Used
10	93-7642	Gear - Driven	1
11	93-7639	Cover - Rear	1
12	93-7641	Gear - Drive	1
13	93-7637	Key - Square	1
14	69-2130	Plug	1
15		Seal - Shaft	1
16		Ring - Retaining	1
*	93-8493	Kit - Seal (Incl. Ref. #5, 6, 8, 15 & 16)	1

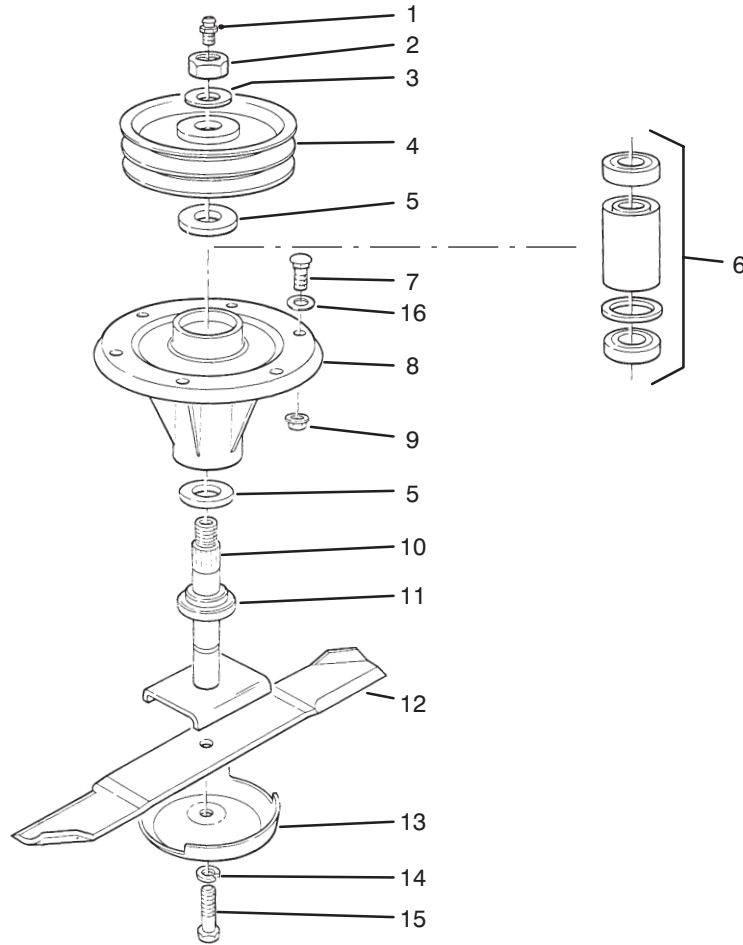

T-0337

SPINDLE ASSEMBLY

Ref. No.	Part No.	Description	No. Used	Ref. No.	Part No.	Description	No. Used
1	302-2	Fitting - Grease Str.	1	8	69-1530	Housing - Spindle	1
*	302-10	Fitting - Grease 45° (Used only on wing deck center & inside spindles)	1	9	32128-21	Nut - Flange Lock	6
2	3296-49	Nut - Lock	1	10	69-6760	Shaft - Spindle	1
3	3-8514	Washer	1	11	92-9800	Spacer - Spindle	1
4	69-8390	Pulley - Spindle	1	12	69-6920	Blade - 20"	1
5	253-154	Seal - Wave	2	13	67-7561	Cup - Anti Scalp	1
6	71-2530	Bearing Assembly	1	14	3253-8	Washer - Lock	1
7	3231-22	Bolt - Carriage	6	15	51-4060	Bolt - Blade	1
				16	3256-24	Washer - Flat	A/R

*Not Illustrated

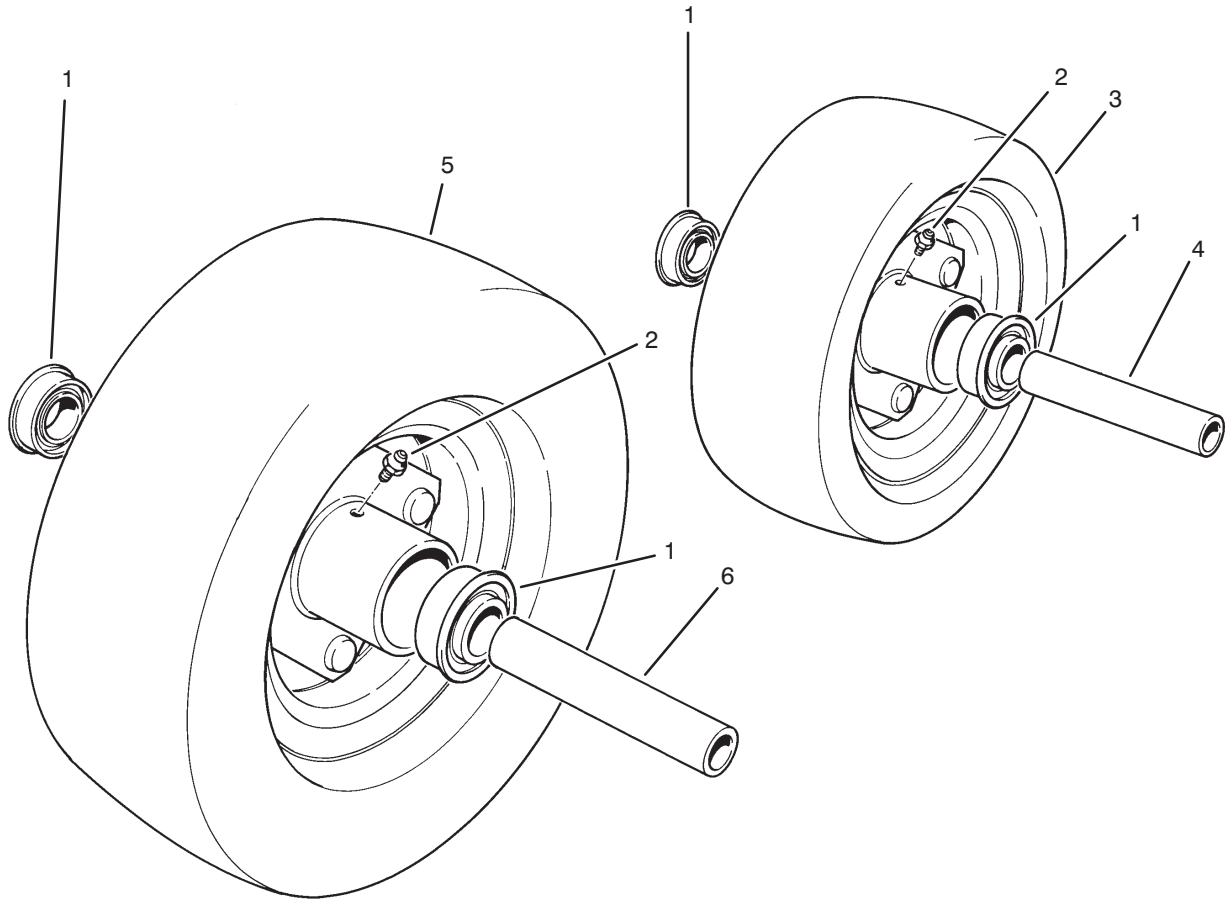

T-0992

10" & 13" SEGMENTED TIRE ASSEMBLIES (Optional)

Ref. No.	Part No.	Description	No. Used
1	251-321	Bearing - Ball	2
2	302-5	Fitting - Grease	1
3	76-1880	10" Segmented Tire Assy. (Incl. Ref. #1, 2 & 4)	1

Ref. No.	Part No.	Description	No. Used
4	251-332	Spacer - Inner	1
5	76-1890	13" Segmented Tire Assy. (Incl. Ref. #1, 2 & 6)	1
6	251-333	Spacer - Inner	1

TORO PART NUMBER INDEX

3317-640

Part No.	Description	Pg. No.	Ref. No.	Qty.	Part No.	Description	Pg. No.	Ref. No.	Qty.
3-2858	Disc - Friction	18	2	1	40-4150	Roller	3	11	1
3-3251	Spring - Compression	4	45	1	40-4160	Guide - Sleeve	3	12	1
3-3710	Tie Rod Assembly	75	39	1	40-4230	Plug	3	17	1
3-6498	Washer	84	34	1	40-4310	Bearing - Thrust Needle	3	25	1
3-6498	Washer - Flat	82	58	1	40-4340	Spring - Extension	3	28	1
3-8514	Washer	93	3	1	40-4350	Spring - Extension	3	29	2
3-8596	Spring - Compression	18	12	1	40-4360	Plate	3	30	1
5-0838	Washer - Flat	80	18	16	40-4370	Bolt	3	31	1
5-0838	Washer - Flat	90	24	32	40-4380	Bracket - Release	3	32	2
5-0838	Washer - Flat	83	30	3	40-9520	Spacer - Split	84	12	2
5-0838	Washer - Flat	84	40	3	40-9520	Spacer - Split	83	3	2
5-3177	Washer - Flat	23	7	4	41-8760	Gasket - Pump	37	49	1
5-3637	Spacer - Terminal	22	4	1	42-1720	Field Core Coil Assembly	9	5	1
5-3637	Washer - Flat	48	13	1	42-6200	Shim - Cushion	83	*	A/R
12-8900	Bolt - Shoulder	36	32	2	42-6200	Shim - Cushion	84	*	A/R
13-4239	Shroud - Fan	44	9	1	43-4000	Breaker - Circuit 40A	11	10	1
13-4969	Deck - Center	81	41	1	43-5920	Washer - Lock	48	14	1
13-4979	Right Wing Deck Assembly	84	18	1	43-5970	Nut - Hex.	48	15	1
13-4989	Deck - Left Wing	83	12	1	43-6110	Plate - Clutch	9	9	1
13-4999	Deck - Wing R.H.	90	*	1	43-6200	Spring - Compression	9	27	1
13-5009	Deck - Wing L.H.	90	20	1	43-6280	Button	13	10	2
13-5059	Arm - Outside Castor	90	19	2	43-6280	Button	14	12	2
13-5069	Arm - Castor L.H.	80	31	1	43-6320	Collar - Locking	9	10	1
17-7190	Spacer	46	23	4	43-6420	Bezel	13	11	2
18-2770	Strap - Ground	72	23	1	43-6420	Bezel	14	13	2
19-1470	Bolt - Shoulder	81	13	4	43-8480	Decal - Danger	83	24	1
20-4360	Tube - Spacer	78	16	2	43-8480	Decal - Danger	90	27	2
20-4840	Clamp - Exhaust	46	12	2	43-8480	Decal - Danger	84	32	1
20-4840	Clamp - Tube	25	15	2	43-8480	Decal - Danger	81	40	1
20-9500	Spacer	4	14	2	44-2210	Body - Indicator Light	4	5	1
21-0141	Joint - Ball	9	20	1	44-2212	Body - Indicator Light	4	12	2
21-1830	Spring - Extension	7	23	1	46-1600	Spacer	4	26	4
21-2070	Yoke - End	36	8	2	46-3380	Bolt - Shoulder	44	23	2
21-3000	Nut - Jam	88	20	2	47-6990	Nut - Hex.	4	9	1
21-3000	Nut - Jam	78	38	2	48-7630	Screw	47	72	1
21-3001	Nut - Jam L.H. Thread	88	3	2	48-7710	Screw - Cap Hex. Hd.	37	10	8
23-1640	Bushing - Taper Lock	81	50	1	48-7780	Screw - Cap Hex. Hd.	2	15	2
23-1640	Bushing - Taper Lock	91	15	2	48-7780	Screw - Cap Hex. Hd.	46	32	6
23-2140	Hose - Radiator Vent	44	7	1	48-7890	Nut - Hex.	47	73	1
23-2270	Bushing - Rubber	9	15	1	48-7930	Nut - Lock	46	6	3
23-7250	Spacer	72	35	1	48-8070	Washer - Lock	46	2	16
23-7270	Nut - Lug	75	24	10	48-8070	Washer - Lock	72	29	1
25-2630	Ring - Back Up	41	63	1	48-9470	Screw - Cap Hex. Hd.	46	25	8
25-2630	Ring Back Up	40	47	1	48-9480	Screw - Cap Hex. Hd.	46	21	4
27-2360	Switch - Ignition	14	16	1	48-9570	Washer - Lock	46	7	3
27-4720	Pin - Pivot Seat	1	14	1	48-9570	Washer - Lock	37	9	8
27-4720	Pin - Pivot, Seat	2	19	1	48-9590	Washer - Lock	46	22	22
27-7120	Nut	69	3	1	49-2500	Element Assembly	57	21	1
27-7220	Detergent - Element	69	*	1	49-6170	Pad - Brake	7	4	1
28-0380	Spacer	4	35	3	49-6171	Pad - Brake Pedal L.H.	6	19	1
28-3580	Ring - Back Up	40	44	1	49-6172	Pad - Brake Pedal R.H.	6	*	1
28-3590	Seal O-Ring	40	43	1	51-3150	Shim - Spring	38	60	A/R
29-6150	Spring - Leaf	37	43	1	51-4060	Bolt - Blade	93	15	1
29-6163	Switch - Micro	6	13	1	51-4910	Bolt	51	24	2
29-6170	Leaf Spring Assembly	37	38	1	51-4910	Bolt	62	28	4
30-8770	Washer - Flat	90	9	8	51-4920	Bolt	52	1	1
30-8770	Washer - Flat	80	32	4	51-4950	Guide	53	18	8
31-0390	Washer - Friction	4	15	3	51-5090	Plug	54	9	1
37-9560	Hose - Fuel	70	1	1	51-5260	Ring - Retaining	54	30	2
39-5710	Plug	2	13	21	51-5280	Cap	54	12	8
39-7591	Thermo Switch Assembly	47	66	1	51-5290	Cotter	54	13	16
39-7592	Switch - Temperature	46	5	1	51-5300	Retainer	54	14	8
39-7593	Temperature Sending Unit	24	15	1	51-5310	Seal	54	15	8
39-7650	Plate - Cover	86	59	2	51-5460	Key	56	16	1
40-0330	Cushion - Rubber	83	4	1	51-5460	Key	54	26	1
40-0330	Cushion - Rubber	84	13	1	51-5470	Plate	54	25	1
40-3890	Trim	2	14	2	51-5500	Bushing No. 1	55	5	1
40-4010	Roller	3	1	4	51-5510	Bushing - No. 2	55	26	1
40-4060	Washer - Rubber	3	26	1	51-5520	Bushing - No. 3	55	27	1
40-4070	Washer	3	24	3	51-5580	Hanger	55	2	1
40-4080	Track - U	3	6	1	51-5600	Cap	55	3	11
40-4090	Rivet - Pop	3	5	2	51-5640	Idler Shaft Assembly	55	36	1
40-4120	Plate - Rubber	3	7	1	51-5650	Pin	56	15	1

*Not Illustrated

TORO PART NUMBER INDEX (Cont.)

Part No.	Description	Pg. No.	Ref. No.	Qty.	Part No.	Description	Pg. No.	Ref. No.	Qty.
51-5650	Pin	55	21	6	51-7830	Cover - Rear	49	16	1
51-5650	Pin	55	35	1	51-7840	Ring - Rubber	49	15	2
51-5840	Washer	53	12	1	51-7850	Nut Assembly	50	1	1
51-5850	Cover	52	15	1	51-7870	Screw Set	50	4	1
51-5860	Gasket	52	14	1	51-7890	Screw Set	50	5	1
51-5890	Oil Seal Assembly	58	17	1	51-7910	Rotor Assembly	50	10	1
51-5950	Stud	58	2	2	51-7930	Stator	50	18	1
51-5970	Nut	58	4	2	51-7950	Terminal Assembly	50	17	1
51-6350	Gear	56	3	1	51-7960	Regulator Assembly	50	16	1
51-6390	Washer	62	29	4	51-7970	Brush	50	15	2
51-6390	Washer	55	33	1	51-8270	Washer	55	29	1
51-6390	Washer - Lock	52	2	11	51-8280	Bolt	55	28	1
51-6390	Washer - Lock	58	3	13	51-8590	Washer	48	3	1
51-6390	Washer - Lock	48	9	2	51-8610	Washer - Lock	56	5	4
51-6390	Washer - Lock	62	9	2	51-8610	Washer - Lock	48	11	2
51-6390	Washer - Lock	51	14	2	51-8640	Bolt	48	8	2
51-6390	Washer - Lock	51	18	4	52-9230	Ring - Retaining	5	3	1
51-6390	Washer - Lock	51	23	4	52-9240	Bushing - Gland Seal	5	4	1
51-6390	Washer - Lock	57	27	4	52-9250	Needle Bearing Kit	5	*	1
51-6400	Plate	52	7	1	52-9260	Screw - Set	5	1	1
51-6430	Bushing	52	10	1	52-9270	Seat - Check Ball	5	24	1
51-6480	Cover	55	9	1	52-9280	Ball - Check	5	22	1
51-6490	Gasket	55	10	1	52-9290	Retainer - Check Ball	5	21	1
51-6820	Washer	57	24	1	52-9320	Drive	5	15	1
51-6830	Relief Valve Assembly	57	25	1	56-7971	Clamp Half - Hydraulic Line	30	26	2
51-6890	Gasket	53	14	1	56-7972	Clamp Half - Hydraulic Line	30	20	4
51-6890	Gasket - Plug	58	15	1	56-7973	Clamp Half - Hydraulic Line	30	19	20
51-6910	Nut	51	32	1	56-7973	Clamp Half - Hydraulic Line	28	44	4
51-6920	Washer - Lock	51	21	2	56-7973	Clamp Half - Hydraulic Line	86	57	6
51-6920	Washer - Lock	51	31	1	56-7974	Clamp - Hydraulic Lines	72	31	2
51-6940	Ring	51	28	1	56-7974	Clamp Half - Hydraulic Line	85	2	2
51-6950	Bearing	51	27	1	56-7974	Clamp Half - Hydraulic Line	30	17	2
51-6960	Key	51	3	1	56-7974	Clamp Half - Hydraulic Line	47	77	2
51-6980	Bearing	51	25	1	56-7978	Clamp Half - Hydraulic Line	30	25	8
51-7020	Nipple	51	6	1	56-7978	Clamp Half - Hydraulic Line	24	42	6
51-7030	Seal	51	10	1	58-3590	Pin - Flywheel	46	24	2
51-7170	Pipe	51	8	1	58-4250	Magnet	42	1	6
51-7200	Clamp	51	42	2	58-5620	Tube - Inner	32	*	2
51-7210	Gasket	51	2	2	58-6290	Poppet Assembly	20	34	3
51-7220	Gasket	51	38	1	58-6310	Spacer	20	28	3
51-7230	Thermostat	51	37	1	58-6320	Wiper - Seal	20	24	3
51-7250	Washer	59	1	4	58-6330	Seat Assy.	20	35	3
51-7250	Washer	59	6	16	58-6340	Seal - O-Ring	20	36	3
51-7250	Washer	55	8	2	58-6350	Plug Assembly	20	11	3
51-7250	Washer	57	9	3	58-6370	Washer - Back-Up	20	10	6
51-7250	Washer	55	38	1	58-6400	Bushing	20	25	3
51-7250	Washer - Lock	54	3	8	58-6420	Cap Assembly	20	30	3
51-7250	Washer - Lock	48	4	1	58-6440	Poppet	20	22	1
51-7250	Washer - Lock	53	4	2	58-6450	Seal - O-Ring	20	12	6
51-7250	Washer - Lock	58	8	28	58-6460	Ring - Retaining	20	29	3
51-7250	Washer - Lock	52	16	5	58-6470	Washer	20	18	A/R
51-7250	Washer - Lock	54	24	2	58-6480	Washer	20	19	A/R
51-7250	Washer - Lock	62	32	2	58-6490	Washer	20	20	A/R
51-7250	Washer - Lock	51	34	4	58-6700	Washer	20	26	3
51-7400	Washer	57	30	4	58-6710	Plug Assy.	20	6	1
51-7400	Washer - Lock	62	16	6	58-6720	Seal - O-Ring	20	7	1
51-7400	Washer - Lock	61	18	2	58-6730	Spring	20	27	3
51-7600	Screw Set	49	4	1	58-6750	Seal - O-Ring	20	17	1
51-7610	Packing	49	5	2	58-6760	Spring	20	3	3
51-7630	Seal - Oil	49	24	1	58-6770	Plunger - Detent	20	4	3
51-7640	Lever Assembly	49	7	1	58-6780	Plug Assy.	20	1	3
51-7650	Spring Assembly	49	8	1	58-6790	Seal - O-Ring	20	5	3
51-7660	Bracket Assembly Center	49	9	1	59-6730	Race - Bearing	5	7	2
51-7670	Solenoid	49	10	1	59-6740	Bearing - Needle Thrust	5	8	1
51-7690	Bearing	49	11	1	59-6820	Centering Spring Kit	5	11	1
51-7720	Clutch Assy.	49	*	1	59-6830	Kit - Centering Pin	5	20	1
51-7730	Gear Pinion Assembly	49	2	1	59-6910	Connector	48	6	1
51-7740	Retaining Ring Assembly	49	1	1	59-7580	Nut	92	1	8
51-7750	Gear Assembly	49	*	1	59-7580	Nut - Hex.	26	24	8
51-7760	Shaft Assembly	49	23	1	59-7590	Washer - Lock	92	2	8
51-7770	Gear - Pinion	49	22	1	59-7590	Washer - Lock	26	12	16
51-7780	Cover Assembly	49	21	1	59-7970	Stud	92	3	8
51-7790	Packing	49	20	2	59-7970	Stud - Threaded	26	23	8

*Not Illustrated

TORO PART NUMBER INDEX (Cont.)

3317-640

Part No.	Description	Pg. Ref. No. No. Qty.	Part No.	Description	Pg. Ref. No. No. Qty.
59-7990	Seal - Gland	26 3 4	63-1540	Pulley - Idler	81 15 3
59-8470	Retainer - Seal	26 4 4	63-1540	Pulley - Idler	91 24 6
59-8500	Gear/Shaft - Front Drive	26 17 1	63-4740	Bolt	53 7 17
59-8570	Seal - Shaft	26 22 1	63-7430	Gauge - Temperature	13 8 1
59-8580	Ring - Retaining	26 21 1	63-7590	Relay	72 19 1
59-8590	Seal - Shaft	26 20 1	63-8280	Head - Fuel Filter	70 4 1
59-8600	Gear - Driven	26 9 2	63-8290	Vent - Air	70 5 1
59-8610	Repair Kit	26 * 1	63-8310	Valve - Drain	70 8 1
60-3780	Seal Kit	20 *	63-8360	Key - Ignition	14 11 1
60-3810	Shaft - Input	35 2 1	66-1340	Decal - Danger	83 23 1
60-3830	Seal - Oil	35 4 1	66-1340	Decal - Danger	84 33 1
60-3840	Cone - Bearing	35 5 1	66-1340	Decal - Danger	90 37 2
60-3850	Cup - Bearing	35 6 2	66-1340	Decal - Danger	82 60 1
60-3860	Bolt - Wheel	35 7 9	66-2490	Hold-Down - Battery	72 16 2
60-3870	Hub	35 8 1	66-2940	Gauge - Fuel	13 25 1
60-3880	Cone - Bearing	35 9 1	66-2950	Hourmeter	13 26 1
60-3890	Bolt - Hex. Hd.	35 10 6	66-3241	Cap - Radiator	44 5 1
60-3900	Gear - Ring	35 24 1	66-6140	Decal - TORO	43 27 1
60-3910	Washer - Flat	35 11 6	66-8530	Track - Adjustment	2 3 1
60-3930	Ring - Retaining	35 25 2	67-4510	Sending Unit - Temperature	46 4 1
60-3940	Washer	35 26 2	67-5360	Decal - Danger	83 25 1
60-3950	Spring - Disengage	35 27 1	67-5360	Decal - Danger	84 31 1
60-3960	Primary Carrier Assembly	35 15 1	67-5360	Decal - Danger	90 39 4
60-3970	Gear - Primary Sun	35 13 1	67-7160	Block - Fuse	11 24 4
60-3980	Washer - Thrust	35 12 1	67-7561	Cup - Anti Scalp	93 13 1
60-3990	Washer - Thrust	35 23 1	67-9560	Shell - Seat	1 2 1
60-4000	Secondary Carrier Assy.	35 20 1	68-6150	Breather	44 50 1
60-4010	Plunger - Disengage	35 22 1	68-7571	Strip - Sealing	23 24 1
60-4020	Seal - O-Ring	35 21 1	68-7572	Strip - Sealing	22 18 1
60-4030	Bolt - Hex. Hd.	35 17 8	68-8080	Wheel - Steering	4 10 1
60-4040	Plug - Pipe	35 16 1	69-0030	Spring - Compression	36 30 2
60-4050	Cover - Large	35 19 1	69-0040	Foam - Lower Grille	42 20 1
60-4060	Cover - Disengage	35 18 1	69-0060	Screw - Cap Hex. Hd.	72 28 1
60-4070	Bolt - Hex. Hd.	35 14 2	69-0060	Screw - Cap Hex. Hd.	46 39 16
60-5210	Clamp	62 15 2	69-0090	Pin - Clevis Engine End	18 * 1
60-5340	Cover Assembly - Front	50 7 1	69-0100	Frame - Assembly	28 49 1
60-5360	Bearing	50 11 1	69-0760	Bracket - Arm Rest L.H.	1 * 1
60-5370	Rectifier Assembly	50 13 1	69-0770	Bracket - Arm Rest R.H.	1 18 1
60-5380	Cover Assembly - Rear	50 12 1	69-0820	Decal - H.O.C.	82 57 1
60-5720	Seal - O-Ring	20 9 6	69-0880	Decal - Torque	80 30 1
60-6450	Disc	20 2 A/R	69-0880	Decal - Torque	90 38 2
60-7040	Bolt	51 40 2	69-0890	Decal - Belt Routing L.H.	90 36 1
60-7110	Bolt	57 10 3	69-0900	Decal - Belt Routing R.H.	90 * 1
60-7110	Bolt	52 18 1	69-0920	Decal - Hydraulic Oil	30 8 1
60-7110	Bolt	54 23 2	69-0930	Decal - Warning	22 12 1
60-7110	Bolt	55 37 1	69-0940	Decal - Caution	30 39 1
60-7120	Nut - Hex.	61 3 12	69-0950	Decal - 580D	43 26 2
60-7160	Rivet	60 1 2	69-0960	Panel - Diagnostic	29 4 1
60-7210	Bolt	52 6 1	69-0970	Panel - Control	4 46 1
60-7280	Bolt	54 2 4	69-0980	Panel - Lever	14 1 1
60-7280	Bolt	53 3 2	69-0990	Panel - Control	14 6 1
60-7280	Bolt	55 7 2	69-1130	Louver - Middle	42 8 1
60-7280	Bolt	58 9 23	69-1140	Louver - Lower	42 31 1
60-7280	Bolt	62 31 2	69-1170	Gauge - Sight	23 2 1
60-7280	Bolt	51 35 1	69-1180	Armrest	1 20 2
60-7290	Bolt	57 29 4	69-1380	Panel - Side R.H.	43 * 1
60-7370	Bolt	59 2 4	69-1390	Panel - Side L.H.	43 12 1
60-7370	Bolt	48 5 1	69-1510	Spacer - Caster	80 2 12
60-7370	Bolt	59 7 16	69-1510	Spacer - Castor	90 35 48
60-7370	Bolt	58 12 5	69-1530	Housing - Spindle	93 8 1
60-7480	Bolt	62 10 2	69-1540	Pivot - Spring	78 34 1
60-7480	Bolt	57 26 4	69-1560	Lever - Lock	4 1 1
60-9760	Nut - Lock	79 11 1	69-1580	Anchor - Latch L.H.	86 55 1
60-9760	Nut - Lock	87 13 1	69-1600	Anchor - Latch R.H.	86 * 1
60-9770	Piston	79 10 1	69-1610	Adapter - Suction Hose	23 8 1
61-2790	Filler - Screen	23 34 1	69-1630	Arm - Latch Pivot	88 12 4
61-4990	Ring - Retaining	79 3 1	69-1640	Radiator	44 12 1
62-5550	Decal	4 47 1	69-1650	Screen - Suction	23 17 1
62-6450	Kit - Retaining Ring	35 28 1	69-1660	Mount - Engine	46 40 4
62-6460	Sealant - RTV (Tube)	35 * 1	69-1670	Cooler - Oil	44 32 1
62-7650	Gasket - Level Sensing Unit	22 1 1	69-1680	Fan	47 62 1
63-0660	Pulley - Drive	82 51 1	69-1690	Clutch - Fan	47 64 1
63-0660	Pulley - Wing Deck Drive	91 14 2	69-1700	Hydraulic Filter Assembly	24 19 1

*Not Illustrated

TORO PART NUMBER INDEX (Cont.)

Part No.	Description	Pg. No.	Ref. No.	Qty.	Part No.	Description	Pg. No.	Ref. No.	Qty.
69-1710	Indicator - Filter	24	25	1	69-2460	Cap	39	6	1
69-1720	Element - Filter	24	21		69-2470	Gasket - Cap	39	7	1
69-1730	Planetary Gear Drive Assy.	32	32	2	69-2480	Screw - Set	39	8	1
69-1740	Spindle	35	3	1	69-2490	Spring - Compression	39	9	1
69-1750	Fuel Filter Assembly	46	44	1	69-2500	Poppet	39	10	1
69-1750	Fuel Filter Assembly	70	*	1	69-2510	Seat	39	11	1
69-1760	Sensor - Water	70	9	1	69-2520	Plug - Pipe	39	31	1
69-1770	Element - Spin-On	70	11	1	69-2530	Seal - O-Ring	39	12	1
69-1780	Lift Valve Assembly	19	2	1	69-2540	Cover Assembly	39	13	1
69-1790	Plunger	20	37	2	69-2550	Repair Kit - Pump	39	*	1
69-1800	Plug Assembly	20	32	3	69-2560	Repair Kit - Pump & Divider	39	*	1
69-1810	Spring	20	33	3	69-2570	Head	79	4	1
69-1820	Spring - Black	20	21	1	69-2580	Shaft w/clevis	79	1	1
69-1830	Plug Assembly	20	16	1	69-2640	Master Cylinder Assembly	7	9	1
69-1840	Plunger	20	31	1	69-2650	Boot - Rod	8	1	1
69-1860	Gerotor	5	16	1	69-2660	Ring - Retaining	8	2	1
69-1880	Spacer	5	17	1	69-2730	Piston Assembly	8	*	1
69-1890	Air Cleaner Assembly	46	15	1	69-2740	Bail - Cover	8	12	1
69-1900	Element Assembly	69	5	1	69-2750	Cover - Reservoir	8	9	1
69-1910	Clamp Assembly	69	4	1	69-2760	Gasket - Diaphragm	8	10	1
69-1920	Baffle	69	2	1	69-2770	Seat - Tube	8	11	1
69-1930	Cup Assembly	69	1	1	69-2960	Hub - Rear Wheel	75	19	2
69-1940	Indicator - Electrical	47	71	1	69-2970	Cap - Hub	75	27	2
69-1950	Band - Air Cleaner	46	28	2	69-2980	Seal - Inner	75	32	2
69-1960	Hydraulic Cylinder Assembly	75	42	2	69-2990	Screw - Drive	75	18	10
69-1960	Steering Cylinder (Complete)	77	*	2	69-3010	Strap - Hold Down	43	6	4
69-1970	Joint - Ball	77	17	1	69-3020	Handle - Latch	42	16	2
69-1980	Nut - Jam	77	16	1	69-3020	Latch	44	20	8
69-1990	Nut - Lock	77	14	1	69-3030	Strike - Latch	42	13	8
69-2000	Piston	77	11	1	69-3050	Motor - Hydraulic Wheel	32	44	2
69-2020	Rod - Piston	77	4	1	69-3070	Washer - Lock	41	62	10
69-2030	Ring - Head	77	7	1	69-3070	Washer - Plain	34	2	10
69-2050	Hydraulic Pump Assembly	25	8	1	69-3080	Plug	41	60	6
69-2060	Shaft End Cover Assembly	26	18	1	69-3090	Adapter - Suction	41	79	1
69-2070	Plate - Flex	26	5	4	69-3100	Screw	41	82	1
69-2070	Plate - Flex	92	7	2	69-3110	Screw	41	73	2
69-2080	Center Section Assembly	26	7	2	69-3120	Plug	41	95	1
69-2090	Gear/Shaft - Rear Drive	26	8	1	69-3130	Plug	40	9	1
69-2100	Rear Cover Assembly	26	11	1	69-3130	Plug - Hole	34	33	1
69-2110	Coupling	26	1	1	69-3140	Bracket - Lifting	41	58	1
69-2120	Seal - O-Ring	26	10	2	69-3150	Screw - Hex. Hd.	41	61	10
69-2130	Plug	92	14	1	69-3150	Screw Hex. Hd.	34	1	10
69-2130	Plug	26	19	1	69-3160	Seal - O-Ring	41	74	3
69-2140	Screw - Cap Hex. Hd.	26	14	4	69-3170	Ring - Retaining	34	19	2
69-2150	Screw - Cap Hex. Hd.	26	13	4	69-3170	Ring - Retaining	40	31	2
69-2160	Port Section Assembly	26	16	1	69-3180	Shaft Pump	40	37	1
69-2170	Adapter Section Assembly	26	2	1	69-3190	Seal - Lip	34	18	1
69-2200	Seal - O-Ring	26	6	2	69-3190	Seal - Lip	40	30	1
69-2210	Seal - O-Ring	26	15	1	69-3200	Ring - Retaining	34	17	2
69-2220	Pump/Valve	37	52	1	69-3200	Ring - Retaining	40	29	2
69-2230	Flow Divider Assembly	39	30	1	69-3210	Bearing - Ball	34	20	1
69-2240	Screw	39	32	4	69-3210	Bearing - Ball	40	32	1
69-2250	Bearing - Sleeve	39	20	4	69-3220	Screw	40	28	1
69-2260	Seal - Load	39	17	1	69-3230	Pin - Spring	40	12	1
69-2270	Seal - Pre-Load	39	18	1	69-3230	Pin - Spring	34	32	1
69-2280	Shaft/Gear - Idler	39	15	1	69-3240	Bearing - Journal	40	25	2
69-2290	Shaft/Gear - Drive	39	28	1	69-3250	Swashplate - Variable	40	24	1
69-2300	Ring - Retaining	39	26	1	69-3370	Bearing - Needle	40	13	1
69-2310	Seal - Shaft	39	27	1	69-3370	Bearing - Needle	34	31	1
69-2320	Plate - Wear	39	16	1	69-3390	Gerotor Assembly	41	89	1
69-2330	Body Assembly	39	21	1	69-3400	Screw Hex. Hd.	41	83	3
69-2340	Pin - Dowel	39	14	2	69-3410	Adapter - A Flange	41	85	1
69-2350	Ring - Sealing	39	19	1	69-3420	Ring - Temper Load	41	86	1
69-2360	Screw	39	23	4	69-3430	Key - Woodruff	41	84	1
69-2370	Washer	39	22	4	69-3440	Seal - O-Ring	41	87	1
69-2380	Screw	39	24	4	69-3450	Pin	34	30	1
69-2390	Washer	39	25	4	69-3450	Pin	40	41	1
69-2400	Seal - O-Ring	39	29	1	69-3460	Plug Expansion	41	80	1
69-2410	Plug	39	1	2	69-3470	Pin	40	36	1
69-2420	Seal - O-Ring	39	2	2	69-3500	Bearing - Sleeve	34	13	1
69-2430	Spring - Compression	39	5	1	69-3500	Sleeve - Bearing	40	34	1
69-2440	Orifice	39	4	1	69-3510	Pin	34	14	1
69-2450	Piston	39	3	1	69-3510	Pin	40	35	1

*Not Illustrated

TORO PART NUMBER INDEX (Cont.)

3317-640

Part No.	Description	Pg. No.	Ref. No.	Qty.	Part No.	Description	Pg. No.	Ref. No.	Qty.
69-3520	Pin	40	26	2	69-4250	Kit - Seal	21	29	3
69-3520	Pin - Spring	34	23	2	69-4260	Solenoid Valve Seal Kit	74	*	3
69-3540	Cover - Gerotor	41	88	1	69-4270	Cartridge Valve Seal Kit	74	*	6
69-3550	Pin	41	81	1	69-4280	Tube - Hydraulic Vent	23	33	1
69-3560	Seal - O-Ring	34	38	2	69-4320	Fitting - Hydraulic 90°	81	8	1
69-3560	Seal - O-Ring	41	55	2	69-4400	Carrier - Wing Deck	86	54	1
69-3570	Ring - Piston	34	39	2	69-4780	Clamp - Gauge	13	23	2
69-3570	Ring - Piston	41	56	2	69-5350	Hose - Air Cleaner Inlet	46	13	1
69-3580	Guide - Spring	40	8	1	69-5360	Hose - Air Cleaner	46	17	1
69-3590	Ring - Retaining	40	7	1	69-5370	Hose - Auxiliary Suction	23	14	1
69-3600	Nut - Hex.	40	6	1	69-5380	Hose - Upper Radiator	44	4	1
69-3610	Nut - Jam	40	5	1	69-5390	Hose - Lower Radiator	44	10	1
69-3620	Cover - Servo Adjustment	40	1	1	69-5410	Manifold - Return	24	10	1
69-3630	Nut Special	40	2	1	69-5430	Pulley - Idler	84	7	1
69-3640	Cover - Servo	40	3	1	69-5430	Pulley - Idler	81	25	1
69-3650	Piston - Servo	40	53	1	69-5440	Hose - Hydraulic	78	12	3
69-3660	Screw - Special	41	91	1	69-5440	Hose - Hydraulic	24	30	1
69-3670	Spring - Compression	41	93	1	69-5440	Hose - Hydraulic	38	58	1
69-3680	Stop - Servo	41	92	1	69-5450	Hose - Hydraulic	38	56	1
69-3690	Bearing	41	54	2	69-5460	Hose - Hydraulic	37	18	1
69-3700	Guide - Spring	41	90	1	69-5460	Hose - Hydraulic	24	14	1
69-3710	Gasket - Servo	40	4	2	69-5470	Hose - Hydraulic	27	16	1
69-3710	Gasket - Servo Cover	34	41	2	69-5470	Hose - Hydraulic	38	57	1
69-3720	Cover - Servo	34	43	2	69-5480	Hose - Hydraulic	27	17	1
69-3720	Cover Servo	41	57	1	69-5480	Hose - Hydraulic	38	59	1
69-3730	Valve - Relief	41	78	2	69-5490	Hose - Cylinder	85	39	4
69-3740	Spring - Compression	41	72	2	69-5500	Hose - Hydraulic	4	33	4
69-3750	Seal - O-Ring	41	77	2	69-5510	Hose - Hydraulic	75	1	4
69-3760	Plug Special	41	71	2	69-5590	Hose - Hydraulic	73	1	2
69-3770	Shim	41	69	1	69-5590	Hydraulic Hose Assembly	25	1	2
69-3780	Plug	41	67	1	69-5600	Hose - Hydraulic	73	9	1
69-3790	Spring Compression	41	70	1	69-5610	Hose - Hydraulic	73	17	1
69-3800	Valve	41	65	1	69-5620	Hose - Hydraulic	44	29	1
69-3810	Valve - By Pass	41	66	1	69-5640	Hose - Hydraulic	25	12	1
69-3820	Sleeve - Control Valve	40	42	1	69-5640	Hose - Suction	23	12	1
69-3830	Spool - Rotary Valve	40	46	1	69-5650	Hose - Hydraulic	24	18	1
69-3840	Seal - O-Ring	40	52	1	69-5650	Hose - Hydraulic	37	22	1
69-3860	Screw - Flange Hd.	40	49	1	69-5670	Cable - Brake	6	22	2
69-3870	Handle - Control Valve	40	50	1	69-5680	Tube - Hydraulic	19	20	1
69-3880	Spring - Neutral Return	40	45	1	69-5680	Tube - Hydraulic	21	9	1
69-3890	Bracket - Neutral Return	40	48	1	69-5700	Tube - Hydraulic	19	18	1
69-3900	Washer	40	51	1	69-5710	Tube - Hydraulic	21	20	1
69-3910	Cylinder Block Assembly	40	39	1	69-5720	Tube - Hydraulic	19	17	1
69-3910	Cylinder Block Kit	34	27	1	69-5730	Tube - Hydraulic	21	33	1
69-3920	Piston Ring & O-Ring Kit	34	*	1	69-5740	Tube - Hydraulic	19	19	1
69-3940	Plug	34	29	1	69-5790	Tube - Hydraulic	27	37	1
69-3950	Shaft - Motor	34	25	1	69-5800	Tube - Hydraulic	23	20	1
69-3960	Screw	34	21	1	69-5800	Tube - Hydraulic	30	28	1
69-3970	Bearing - Journal	34	22	2	69-5810	Tube - Hydraulic Return	28	*	1
69-3980	Washplate - Variable	34	24	1	69-5820	Tube - Hydraulic	21	31	1
69-3990	Plate - Motor Valve	34	28	1	69-5830	Tube - Hydraulic	21	32	1
69-4020	Piston - Servo	34	37	1	69-5850	Tube - Hydraulic	21	18	1
69-4030	Spring - Servo	34	40	1	69-5860	Tube - Hydraulic	19	16	1
69-4040	Stop - Servo Piston	34	42	1	69-5860	Tube - Hydraulic	21	34	1
69-4060	Counterbalance Manifold	21	*	1	69-5870	Tube - Hydraulic	19	22	1
69-4060	Counterbalance Manifold	19	26	1	69-5870	Tube - Hydraulic	21	28	1
69-4070	Manifold - Counter Balance	21	14	1	69-5890	Tube - Hydraulic	21	5	1
69-4080	Valve - Hydraulic Cartridge	21	1	1	69-5890	Tube - Hydraulic	19	21	1
69-4090	Valve - Hydraulic Cartridge	21	36	1	69-5900	Tube - Hydraulic	44	31	1
69-4100	Valve - Hydraulic Cartridge	21	15	1	69-5910	Tube - Hydraulic	21	19	1
69-4110	Valve - Hydraulic Cartridge	21	30	2	69-5910	Tube - Hydraulic Diagnostic	29	6	1
69-4120	Valve - Hydraulic Cartridge	21	10	1	69-5920	Tube - Diagnostic	29	8	1
69-4130	Plug - Orifice .047	21	39	2	69-5920	Tube - Hydraulic	21	37	1
69-4140	Plug - Orifice .120	21	38	1	69-5930	Tube - Hydraulic R.H.	32	*	1
69-4150	PTO Manifold Assembly	74	*	1	69-5940	Tube - Hydraulic L.H.	32	2	1
69-4150	PTO Manifold Assembly	72	1	1	69-5950	Tube - Hydraulic	24	32	1
69-4170	Valve - Cartridge (600 lbs)	73	5	3	69-5950	Tube - Hydraulic	28	57	1
69-4180	Valve - Cartridge (3000 lbs)	73	8	3	69-5970	Tube - Hydraulic R.H.	85	*	1
69-4190	Valve - Cartridge (20 lbs)	73	40	3	69-5980	Tube - Hydraulic L.H.	85	21	1
69-4200	Valve - Cartridge (75 lbs)	73	38	3	69-5990	Tube - Hydraulic	24	12	1
69-4220	Plug - Orifice	74	47	1	69-5990	Tube - Hydraulic	86	53	1
69-4230	Cartridge Valve Seal Kit	74	*	6	69-6000	Tube - Hydraulic	24	11	1
69-4240	Kit - Seal	21	11	1	69-6000	Tube - Hydraulic	86	49	1

*Not Illustrated

TORO PART NUMBER INDEX (Cont.)

Part No.	Description	Pg. No.	Ref. No.	Qty.	Part No.	Description	Pg. No.	Ref. No.	Qty.
69-6010	Tube - Hydraulic	76	50	1	69-6870	Plate - Magnet	81	31	4
69-6020	Tube - Hydraulic	76	51	1	69-6890	Spacer - Spring	81	47	1
69-6030	Tube - Hydraulic	27	35	1	69-6900	Shaft - Hinge	83	14	1
69-6030	Tube - Hydraulic	86	46	1	69-6900	Shaft - Hinge	84	20	1
69-6040	Tube - Hydraulic	27	34	1	69-6910	Bracket - Support	84	11	1
69-6040	Tube - Hydraulic	86	50	1	69-6910	Bracket - Support	83	19	1
69-6050	Tube - Hydraulic	27	33	1	69-6920	Blade - 20	93	12	1
69-6050	Tube - Hydraulic	86	51	1	69-6960	Spacer - Idler	81	14	4
69-6060	Tube - Hydraulic	27	38	1	69-6960	Spacer - Idler	91	23	6
69-6060	Tube - Hydraulic	86	47	1	69-6970	Spacer - Idler	84	17	1
69-6070	Tube - Hydraulic	30	36	1	69-6970	Spacer - Idler	81	26	1
69-6070	Tube - Hydraulic	86	48	1	69-6980	Valve - Check	4	38	1
69-6080	Tube - Hydraulic	30	35	1	69-6990	Lever - Valve Mid.	19	*	1
69-6080	Tube - Hydraulic	86	52	1	69-7000	Lever - Valve R.H.	19	*	1
69-6100	Tube - Hydraulic Pressure	28	50	1	69-7010	Lever - Valve L.H.	19	5	1
69-6110	Hydraulic Tube Assembly	25	13	1	69-7040	Holder - Cup	11	13	1
69-6120	Tube - Hydraulic	30	16	1	69-7100	Support - Radiator Lower	44	24	1
69-6130	Tube - Hydraulic	30	15	1	69-7120	Grille - Upper	42	27	1
69-6140	Tube - Hydraulic	73	45	1	69-7150	Grille - Lower	42	23	1
69-6140	Tube - Hydraulic R.H.	85	*	1	69-7170	Clevis - Deck	90	10	2
69-6150	Tube - Hydraulic	73	46	1	69-7200	Tube - Vent	22	14	1
69-6150	Tube - Hydraulic R.H.	85	*	1	69-7210	Tube - Latch	88	5	2
69-6160	Tube - Hydraulic	73	11	1	69-7290	Mount - Ball Joint	80	5	2
69-6170	Tube - Hydraulic	73	21	1	69-7420	Axle - Rear	75	16	1
69-6170	Tube - Hydraulic L.H.	85	6	1	69-7570	Bracket - Front Engine	46	*	1
69-6180	Tube - Hydraulic	73	20	1	69-7580	Bracket - Front Engine	46	42	1
69-6180	Tube - Hydraulic L.H.	85	22	1	69-7650	Pedal - Traction	9	24	1
69-6190	Tube - Hydraulic	27	23	1	69-7700	Pedal - Brake	7	3	1
69-6200	Tube - Hydraulic	27	22	1	69-7700	Pedal - Brake	6	20	2
69-6240	Fitting - Hydraulic 90°	25	3	2	69-7720	Pawl - Brake	6	7	1
69-6250	Engine - Assembly	46	9	1	69-7740	Support - Steering Gear	4	21	1
69-6260	Magnet	11	6	1	69-7760	Link - Steering Gear	4	19	1
69-6260	Magnet - Cover	83	15	2	69-7790	Pin - Brake Arm	6	11	1
69-6260	Magnet - Cover	84	15	2	69-7810	Bracket - Valve	19	11	1
69-6260	Magnet - Cover	81	32	4	69-7840	Mount - Brake Arm	6	16	1
69-6260	Magnet - Cover	91	20	8	69-7880	Arm - Brake L.H.	6	23	1
69-6270	Fork - Castor	80	24	2	69-7890	Arm - Brake R.H.	6	2	1
69-6340	Plate - Motor Mounting R.H.	91	*	1	69-7920	Support - Lift Arm L.H.	78	27	2
69-6360	Plate - Motor Mounting L.H.	91	3	1	69-7940	Support - Lift Arm R.H.	78	4	2
69-6390	Plate - Gearbox	82	52	1	69-7960	Support - Axle	75	12	2
69-6420	Bar - Lift L.H.	90	18	1	69-8040	Arm - Throttle	18	4	1
69-6470	Bushing - Flange	89	5	8	69-8080	Cover - Tool Box	10	3	1
69-6470	Bushing - Flange	75	6	6	69-8110	Box - Tool	10	1	1
69-6470	Bushing - Flange	90	16	20	69-8160	Tower - Steering	4	31	1
69-6470	Bushing - Flange	80	26	4	69-8210	Support - Cover	11	26	1
69-6470	Bushing - Flange	78	29	4	69-8230	Bracket - Trim L.H.	43	17	1
69-6470	Bushing - Flange	85	30	4	69-8250	Bracket - Trim R.H.	43	20	1
69-6480	Bar - Lift R.H.	90	*	1	69-8290	Frame - Battery	72	33	1
69-6490	Plate - Tension	81	43	1	69-8390	Pulley - Spindle	93	4	1
69-6550	Arm - Tension	81	38	1	69-8410	Screw - Cap Hex. Hd.	46	34	4
69-6610	Arm - Idler	81	23	1	69-8420	Washer - Lock	46	35	4
69-6610	Idler Arm Assembly	84	27	1	69-8430	Hose - Hydraulic	44	18	2
69-6640	Hinge - Left Front	83	13	1	69-8440	Hose - Hydraulic	78	9	1
69-6670	Hinge - Left Rear	83	17	1	69-8440	Hose - Hydraulic	24	31	1
69-6690	Hinge - Right Front	84	28	1	69-8450	Hose - Hydraulic	44	30	1
69-6710	Hinge - Right Rear	84	23	1	69-8460	Fitting - Hydraulic Straight	47	55	2
69-6730	Skid	83	7	1	69-8470	Spring - Torsion	78	32	1
69-6730	Skid	90	21	4	69-8480	Spring - Compression	88	6	2
69-6730	Skid	84	29	1	69-8490	Bracket - Throttle Cable	46	36	1
69-6760	Shaft - Spindle	93	10	1	69-8500	Shim - Hinge Bracket	43	21	6
69-6780	Cover - Center Left	81	30	1	69-8510	Cover - Steering Tower	4	41	1
69-6790	Cover - Center Right	82	54	1	69-8520	Bracket - Hinge	43	28	2
69-6800	Cover - Inner L.H.	91	1	1	69-8590	Support - Radiator Upper	44	2	1
69-6810	Cover - Outer L.H.	91	16	1	69-8650	Cowl - Radiator	42	10	1
69-6820	Cover - Inner R.H.	91	*	1	69-8690	Support - Grille	42	15	1
69-6830	Cover - Outer R.H.	91	*	1	69-8750	Arm - Brake	7	1	1
69-6840	Cover - Right Wing	84	2	1	69-8790	Plate - Reinforcing	80	4	2
69-6850	Cover - Left Wing	83	22	1	69-8790	Plate - Reinforcing	90	4	2
69-6860	Washer - Castor	80	25	8	69-8830	Arm - Inside Castor	90	1	2
69-6860	Washer - Thrust	90	33	28	69-8860	Arm - Castor R.H.	80	7	1
69-6870	Plate - Magnet	84	3	2	69-8890	Cap - Spindle	75	13	2
69-6870	Plate - Magnet	91	18	8	69-8900	Spacer	28	52	2
69-6870	Plate - Magnet	83	21	2	69-8910	Washer	36	3	2

*Not Illustrated

TORO PART NUMBER INDEX (Cont.)

3317-640

Part No.	Description	Pg. Ref.		Part No.	Description	Pg. Ref.			
		No.	Qty.			No.	Qty.		
69-8910	Washer	28	51	4	69-9761	Plate - Cover	85	13	1
69-8920	Washer	30	4	4	69-9761	Plate - Cover	30	14	5
69-8930	Washer	27	26	4	69-9761	Plate - Cover	24	43	3
69-8940	Washer	27	5	12	69-9761	Plate - Cover	47	78	1
69-8940	Washer	85	16	20	69-9800	Tire	32	28	2
69-8950	Spacer	30	5	2	69-9810	Joint - Ball	77	2	1
69-8960	Spacer	27	27	2	69-9880	Tire	75	22	2
69-8970	Spacer	85	17	10	69-9940	Nut - Jam	32	40	4
69-8970	Spacer	27	31	6	69-9950	Spring - Extension	32	37	4
69-8980	Washer	30	30	8	69-9960	Link	32	36	4
69-8990	Spacer	30	33	4	69-9970	Stud	32	35	4
69-9000	Spacer	85	9	4	69-9980	Ball	32	39	6
69-9010	Washer	85	10	8	69-9990	Disc - Actuating	32	38	4
69-9020	Nut - Special	37	26	1	70-2800	Pulley Assembly	50	2	1
69-9030	Post - Neutral Device	9	14	1	70-2810	Spring - Return	50	14	2
69-9040	Cam - Neutral Device	37	31	1	70-2820	Bolt	62	21	2
69-9050	Bar - Neutral Device	37	45	1	70-2830	Bolt	62	20	3
69-9070	Bracket - Clamp	47	58	1	70-2830	Bolt - Cap Hex. Hd.	61	17	2
69-9100	Washer - Latch	88	7	2	70-2840	Bolt	62	17	1
69-9110	Rod - Engine Run Solenoid	46	49	1	70-2850	Bolt	51	22	2
69-9120	Rod - Hood Prop	72	5	1	70-2850	Bolt	63	42	4
69-9130	Bracket - Throttle	18	11	1	70-2860	Bolt	52	17	4
69-9140	Link - Valve Lever	19	6	3	70-2860	Bolt	51	33	1
69-9150	Shaft - Valve Lever	19	9	1	70-2870	Bolt	54	1	4
69-9180	Pin - Cylinder	78	17	2	70-2880	Bolt	56	6	4
69-9190	Bushing - Cylinder	85	38	2	70-2890	Bolt	51	15	2
69-9190	Tube - Cylinder Bushing	78	15	2	70-2890	Bolt	55	34	1
69-9200	Pin - Brake Pawl	6	8	1	70-2900	Bolt	58	18	11
69-9210	Lever - Brake Latch	6	4	1	70-2900	Bolt	51	19	1
69-9220	Support - Tube Clamp	25	17	2	70-2910	Bolt	51	4	1
69-9230	Shaft - Steering Pivot	4	2	1	70-2920	Bolt	51	20	3
69-9240	Roller - Cam	89	16	2	70-2930	Bolt	52	19	9
69-9250	Shaft - Roller	89	18	2	70-2930	Bolt	53	22	4
69-9260	Pin - Clevis	80	29	2	70-2940	Bolt	48	12	2
69-9290	Pad - Bumper	81	17	2	70-2950	Stud	51	30	4
69-9300	Cushion - Rubber	89	8	2	70-2960	Nut	62	23	2
69-9300	Cushion - Rubber	85	34	2	70-2970	Nut	54	4	8
69-9300	Cushion - Rubber	28	41	2	70-2980	Nut	62	39	4
69-9310	Plate - Lever	14	20	1	70-2990	Washer	52	3	1
69-9330	Cover	30	1	1	70-2990	Washer	51	16	1
69-9340	Rod - Brake	7	15	1	70-2990	Washer	57	28	4
69-9350	Bracket - Hood Prop Rod	72	2	1	70-2990	Washer	62	30	4
69-9360	Bracket - Fuel Filter	46	53	1	70-3000	Pin	55	4	2
69-9370	Louver - Top	42	6	2	70-3010	O-Ring	60	23	1
69-9390	Shaft - Pedal	9	11	1	70-3020	Ring	56	20	8
69-9400	Bracket - Hose Support	76	49	1	70-3030	Tube	57	4	1
69-9420	Muffler	46	11	1	70-3040	Hose	61	14	1
69-9430	Foam - Tool Box	10	2	1	70-3050	Bolt	54	28	1
69-9440	Panel - Steering Tower	4	4	1	70-3060	Gasket	61	1	2
69-9450	Bracket - Wing Hose L.H.	85	7	1	70-3070	Gasket	57	33	1
69-9460	Bracket - Wing Hose R.H.	85	*	1	70-3080	Gasket	55	23	1
69-9470	Cover - Access	28	63	1	70-3090	Clamp	57	3	1
69-9480	Bracket - Neutral Device	37	28	1	70-3090	Clamp - Hose	61	13	2
69-9520	Panel - Rear	43	9	1	70-3100	Plug	53	13	1
69-9530	Bracket - Air Cleaner	46	29	1	70-3110	Plug - Drain	58	11	1
69-9540	Bracket - Steering Gear	4	18	1	70-3120	Plug	55	22	1
69-9550	Plate - Adapter	46	31	1	70-3130	Gasket	59	4	1
69-9560	Housing - Control	11	1	1	70-3140	Pipe	62	36	1
69-9570	Front Lift Arm Assy. R.H.	78	43	1	70-3150	Pipe	62	37	1
69-9580	Front Lift Arm Assy. L.H.	78	39	1	70-3160	Screw	54	5	8
69-9650	Screen - Cowl	42	9	2	70-3170	Nut	56	11	1
69-9680	Shaft - Latch	88	10	2	70-3180	Clamp	62	18	3
69-9700	Mount - Rubber	90	5	8	70-3190	Clamp	62	19	3
69-9710	Nut - Lock	47	63	4	70-3200	Washer	63	50	1
69-9720	Strip - Sealing	42	28	2	70-3210	Packing	63	48	4
69-9721	Strip - Sealing	42	18	3	70-3220	O-Ring	57	2	1
69-9722	Trim - Sealing	42	35	1	70-3230	Plug	58	14	1
69-9723	Seal - Hood Bottom	43	15	2	70-3230	Plug	53	15	1
69-9724	Seal - Hood Front	43	29	1	70-3240	Plug	63	51	1
69-9730	Switch - Toggle	14	18	1	70-3250	Bolt	63	47	2
69-9740	Switch - Toggle	14	14	1	70-3260	Armature Assembly	49	12	1
69-9760	Plate - Cover	30	10	3	70-3270	Spring - Brush	49	18	4
69-9761	Plate - Clamp	72	36	1	70-3280	Cover Assembly Front	49	6	1

*Not Illustrated

TORO PART NUMBER INDEX (Cont.)

Part No.	Description	Pg. Ref. No. No. Qty.	Part No.	Description	Pg. Ref. No. No. Qty.
70-3290	Brush Holder Assembly	49 17 1	70-4000	Plate - 0.9	64 * A/R
70-3300	Yoke Assembly	49 19 1	70-4010	Plate - 1.0	64 * A/R
70-3310	Bolt Set	49 14 1	70-4020	Plate - 1.1	64 * A/R
70-3320	Bearing	50 8 1	70-4030	Plate - 1.2	64 * A/R
70-3330	Bearing	49 13 1	70-4040	Plate - 1.3	64 * A/R
70-3340	Connector	61 11 1	70-4050	Plate - 1.4	64 * A/R
70-3340	Connector	57 34 1	70-4060	Plate - 0.1	64 * A/R
70-3350	Cap	55 11 6	70-4070	Plate - 0.2	64 * A/R
70-3360	Cap	53 16 4	70-4080	Plate - 0.3	64 * A/R
70-3370	Cap	55 25 3	70-4090	Plate - 0.4	64 * A/R
70-3380	Cap	53 19 15	70-4100	Plate - 0.5	64 * A/R
70-3390	Plug	53 17 4	70-4110	Plate - 0.15	64 * A/R
70-3400	Plug	55 6 6	70-4120	Capsule	66 30 1
70-3410	Plug	55 13 1	70-4130	Housing	66 3 1
70-3420	Clip	57 5 1	70-4140	Stopper	66 27 1
70-3430	Clamp - Hose	61 5 3	70-4150	Gasket	66 6 1
70-3440	Clamp - Hose	61 9 1	70-4160	Gasket	66 1 1
70-3450	V-Belt	51 1 1	70-4170	Flyweight Assembly	67 71 1
70-3460	Washer	62 40 8	70-4180	Nut	67 69 1
70-3470	Washer - Drain Plug	58 10 1	70-4190	Sleeve	67 68 1
70-3480	Stud	61 4 6	70-4200	Plate	67 67 1
70-3490	Cover	65 41 1	70-4210	Plate	66 8 1
70-3500	Holder	65 50 4	70-4220	Swiveling Lever Assembly	66 12 1
70-3510	Stopper	65 49 4	70-4230	Bushing	66 21 2
70-3520	Spring	65 48 4	70-4240	E-Ring	67 59 1
70-3530	Gasket	65 46 4	70-4250	Tension Lever Assembly	66 19 1
70-3540	Valve Assembly	65 45 4	70-4260	Adapter Assembly	67 * 1
70-3550	Element Assembly	65 44 4	70-4270	Screw	67 60 1
70-3560	Pinion	64 12 4	70-4280	Spring	67 62 1
70-3570	Screw	64 11 4	70-4290	Adapter	67 63 1
70-3580	Sleeve	64 13 4	70-4300	Nut	67 58 1
70-3590	Seat	64 14 4	70-4310	Nut	66 32 1
70-3600	Spring	64 15 4	70-4320	Lever Assembly	66 17 1
70-3610	Seat	64 16 4	70-4330	Bushing	66 38 1
70-3620	Body	64 19 4	70-4340	Shackle Assembly	66 18 1
70-3630	Tappet Assembly	65 * 1	70-4350	Shaft	66 24 1
70-3640	Pin	64 18 4	70-4360	Plug	66 23 2
70-3650	Bushing	64 20 4	70-4370	Spring	66 13 1
70-3660	Roller	64 21 4	70-4380	Spring	66 16 1
70-3670	Plug	64 22 4	70-4390	Screw	67 56 1
70-3680	Camshaft	65 30 1	70-4400	Cover	66 25 1
70-3690	Ring	64 8 1	70-4410	Pin	67 57 1
70-3700	Ring	65 38 1	70-4420	Bushing	67 53 1
70-3710	Plate - 0.10	64 7 A/R	70-4430	Screw	67 73 1
70-3720	Plate - 0.12	64 * A/R	70-4440	Nut	66 33 1
70-3730	Plate - 0.14	64 * A/R	70-4450	Nut	66 34 1
70-3740	Plate - 0.16	64 * A/R	70-4460	Plate	66 45 1
70-3750	Plate - 0.18	64 * A/R	70-4470	Lever	67 55 1
70-3760	Plate - 0.50	64 * A/R	70-4480	Shaft	67 54 1
70-3770	Plate - 0.30	64 * A/R	70-4490	Cup	66 49 1
70-3780	Plate - 0.1	65 37 A/R	70-4500	Spring	66 46 1
70-3790	Plate - 0.15	65 * A/R	70-4510	Spring	66 48 1
70-3800	Plate - 0.3	65 * A/R	70-4520	Spring	66 47 1
70-3810	Plate - 0.5	65 * A/R	70-4530	Cover	66 51 1
70-3820	Cover	65 35 1	70-4540	Slider	67 64 1
70-3830	Gasket	65 31 1	70-4550	Plate	66 40 1
70-3840	Rack	64 2 1	70-4560	Adjusting Lever Assembly	66 43 1
70-3850	Screw	65 42 1	70-4570	Stop Lever Assembly	66 50 1
70-3860	Washer	64 3 2	70-4580	Cap	66 20 1
70-3870	Washer	65 40 2	70-4590	Plug	66 5 1
70-3870	Washer	68 12 4	70-4600	Housing Assembly	68 11 1
70-3880	Plate	64 1 2	70-4610	Valve	68 5 2
70-3890	Washer	66 31 2	70-4620	Spring	68 4 2
70-3900	Packing	64 9 2	70-4630	Gasket	68 3 2
70-3910	Washer	65 25 2	70-4640	Support	68 20 1
70-3920	Cover Assembly	65 * 1	70-4650	Pump Assembly	68 2 1
70-3930	Gasket	64 5 1	70-4660	Rod, Blue Small Dia.	68 19 A/R
70-3940	Plate	65 28 2	70-4670	Rod, Red Small Dia.	68 * A/R
70-3950	Screw	64 10 2	70-4680	Rod, Yellow Small Dia.	68 * A/R
70-3960	Valve	64 4 1	70-4690	Rod, Green Small Dia.	68 * A/R
70-3970	Plate - 0.6	64 17 A/R	70-4700	Rod, White Small Dia.	68 * A/R
70-3980	Plate - 0.7	64 * A/R	70-4710	Rod, Brown Big Dia.	68 * A/R
70-3990	Plate - 0.8	64 * A/R	70-4720	Piston	68 18 1

*Not Illustrated

TORO PART NUMBER INDEX (Cont.)

3317-640

Part No.	Description	Pg. Ref. No. No. Qty.	Part No.	Description	Pg. Ref. No. No. Qty.
70-4730	Tappet	68 7 1	70-5401	Ring Set - O.S. 0.25mm	56 * 4
70-4740	Roller	68 8 1	70-5402	Ring Set - O.S. 0.50mm	56 * 4
70-4750	Pin	68 10 1	70-5410	Pin	56 21 4
70-4760	Block	68 6 2	70-5420	Nut	56 10 8
70-4770	Spring	68 17 1	70-5430	Bearing - Rod (Std.)	56 8 8
70-4780	Plug	68 15 1	70-5431	Bearing - Rod U.S. 0.25mm	56 * 4
70-4790	Filter	68 13 1	70-5432	Bearing - Rod U.S. 0.50mm	56 * 4
70-4800	Screw	68 14 1	70-5433	Bearing - Rod U.S. 0.75mm	56 * 4
70-4810	Body Assembly	62 8 4	70-5440	Pulley	56 13 1
70-4820	Pin	62 5 4	70-5450	Idler Assembly	52 9 1
70-4830	Spring	62 6 4	70-5460	Gasket	59 9 1
70-4840	Nut	62 1 4	70-5470	Manifold	59 10 1
70-4850	Washer 2.15 mm	62 * A/R	70-5480	Pipe - Oil	61 16 1
70-4860	Washer 1.00 mm	62 7 A/R	70-5490	Pipe - Oil	61 15 1
70-4870	Washer 1.05 mm	62 * A/R	70-5500	Strainer	57 31 1
70-4880	Washer 1.10 mm	62 * A/R	70-5510	Gasket	57 19 1
70-4890	Washer 1.275 mm	62 * A/R	70-5520	Union	57 22 1
70-4900	Washer 1.325 mm	62 * A/R	70-5530	Bracket Assembly	57 23 1
70-4910	Washer 1.775 mm	62 * A/R	70-5540	Oil Filter Assembly	57 * 1
70-4920	Washer 0.95 mm	62 * A/R	70-5550	Gasket	57 20 1
70-4930	Packing	62 4 4	70-5560	Gage	58 13 1
70-4940	Housing Assembly	65 43 1	70-5570	Breather	57 1 1
70-4950	Hose - 90° Elbow	61 8 1	70-5570	Breather	53 21 1
70-4960	Clamp - R	61 21 1	70-5580	Stay	57 6 1
70-4970	Gasket	61 19 1	70-5590	Connector	51 41 1
70-4980	Bolt - Cap Hex Hd.	61 2 1	70-5600	Water Pump Assembly	51 5 1
70-4990	Spring	54 17 8	70-5610	Impeller	51 11 1
70-5000	Retainer	54 18 8	70-5620	Connector	51 9 1
70-5010	Tappet	54 11 8	70-5630	Shaft	51 26 1
70-5020	Gear - Camshaft	52 8 1	70-5640	Bracket	51 12 1
70-5020	Gear - Camshaft	54 22 1	70-5650	Gasket	51 7 1
70-5030	Pipe	57 35 1	70-5660	Gasket	51 17 1
70-5040	Hose	51 43 1	70-5670	Stay	51 13 1
70-5050	Cover	51 39 1	70-5680	Pulley	51 29 1
70-5060	Joint	62 27 1	70-5690	Elbow	51 36 1
70-5070	O-Ring	62 35 1	70-5700	Fuel Feed Pump	62 25 1
70-5080	Bushing	54 6 8	70-5710	Fuel Filter Assembly	63 * 1
70-5090	Gasket	53 20 1	70-5720	Bracket	63 49 1
70-5100	Gasket	57 7 1	70-5730	Filter Element Assembly	62 38 1
70-5110	Washer	54 31 2	70-5740	Plate	48 2 1
70-5120	Bolt	57 32 1	70-5750	Bracket	48 10 1
70-5130	Gasket	53 11 1	70-5760	Alternator Assembly	48 1 1
70-5140	Plug	53 5 1	70-5770	Lever	62 22 1
70-5150	Rocker Assembly - Intake	54 32 4	70-5780	Seal	52 13 1
70-5160	Rocker Assembly - Exhaust	54 27 4	70-5790	Case	52 4 1
70-5170	Pipe	54 29 1	70-5800	Pin	56 7 2
70-5180	Rocker Shaft Assembly	54 8 1	70-5810	Plate	56 14 1
70-5190	Spring	54 7 3	70-5820	Cone	56 12 1
70-5200	Bracket	54 33 4	70-5830	Gear - Crankshaft	52 12 1
70-5230	Rod - Push	54 10 8	70-5840	Oil Pump Assembly	57 14 1
70-5240	Seal	55 15 4	70-5850	Cover	57 18 1
70-5250	Plate	55 31 1	70-5860	Starter Assembly	48 7 1
70-5260	Gasket	55 39 1	70-5870	Insert - Exhaust	53 9 4
70-5270	Cover	57 8 1	70-5880	Insert - Inlet	53 10 4
70-5280	Sleeve	55 41 4	70-5890	Flange	53 6 1
70-5290	Hanger	55 40 1	70-5900	Cylinder Head Assembly	53 8 1
70-5300	Bolt	55 19 10	70-5910	Valve - Inlet	54 20 4
70-5310	Fitting - 90° Elbow	61 12 1	70-5920	Valve - Exhaust	54 19 4
70-5320	Pin	55 30 2	70-5930	Spring	54 16 8
70-5330	Gasket	58 5 1	70-5940	Camshaft	54 21 1
70-5340	Valve	55 32 4	70-5950	Connector	55 12 1
70-5350	Bearing - Main (Std.)	55 14 10	70-5960	Crankcase Assembly	55 1 1
70-5351	Bearing - Main U.S. 0.25mm	55 14 10	70-5970	Housing	58 1 1
70-5352	Bearing - Main U.S. 0.50mm	55 14 10	70-5980	Piston (Std.)	56 22 4
70-5353	Bearing - Main U.S. 0.75mm	55 14 10	70-5981	Piston - O.S. 0.25mm	56 * 4
70-5360	Plate - Thrust (Std.)	55 20 3	70-5982	Piston - O.S. 0.50mm	56 * 4
70-5361	Plate - Thrust O.S. 0.15mm	55 20 3	70-5990	Connecting Rod - Std.	56 1 4
70-5362	Plate - Thrust O.S. 0.30mm	55 20 3	70-6000	Bushing	56 2 4
70-5363	Plate - Thrust O.S. 0.45mm	55 20 3	70-6010	Bolt	56 19 8
70-5370	Gasket	52 5 1	70-6020	Crankshaft Assembly	56 18 1
70-5380	Pan - Oil	58 7 1	70-6030	Flywheel Assembly	56 4 1
70-5390	Gasket	58 6 1	70-6040	Gear - Injection Pump	52 11 1
70-5400	Ring Set - Std.	56 23 4	70-6050	Manifold	59 5 1

*Not Illustrated

TORO PART NUMBER INDEX (Cont.)

Part No.	Description	Pg. No.	Ref. No.	Qty.	Part No.	Description	Pg. No.	Ref. No.	Qty.
70-6060	Gasket	59	8	1	70-6770	Nut	66	36	1
70-6070	Pipe	61	7	1	70-6780	Nut	65	33	1
70-6080	Hose	61	6	1	70-6790	Packing	66	28	1
70-6090	Elbow	59	3	1	70-6800	E-Ring	64	23	4
70-6100	Pipe - No. 2	62	12	1	70-6810	E-Ring	66	11	2
70-6110	Pipe - No. 4	62	14	1	70-6820	Ring	68	9	1
70-6120	Pipe	63	41	1	70-6830	Pin	62	3	8
70-6130	O-Ring	62	33	1	70-6840	Bearing	65	36	1
70-6140	Washer	63	43	4	70-6850	Bearing	64	6	2
70-6150	Gasket	63	45	4	70-6860	Key	66	14	1
70-6160	Nozzle Assembly	63	46	4	70-6870	Key	66	2	1
70-6170	Nozzle Tip Assembly	62	2	4	70-6880	Key	65	29	1
70-6180	Injection Pump	62	26	1	70-6890	O-Ring	66	52	1
70-6190	Pipe - No. 1	62	11	1	70-6900	O-Ring	65	26	1
70-6200	Pipe - No. 3	62	13	1	70-6910	O-Ring	65	47	4
70-6210	Flange	62	34	1	70-6920	Seal	66	44	1
70-6220	Gland	63	44	4	70-6930	Screw	64	24	1
70-6230	Coupling Assembly	60	17	1	70-6940	Screw	68	1	1
70-6240	Gasket	61	10	1	70-6940	Screw	65	39	1
70-6250	Gasket	59	11	1	70-6990	Level Sensing Unit Assembly	22	2	1
70-6250	Gasket	61	20	1	71-0060	Support - Foam	43	8	1
70-6260	Plate	60	21	1	71-0210	Foam - Radiator Seal	44	13	1
70-6270	O-Ring	60	7	1	71-0220	Foam - Louver Lower	42	11	1
70-6280	Deflector	60	9	1	71-0230	Foam - Louver Middle	42	7	1
70-6290	Insert	60	8	1	71-0240	Foam - Louver Top	42	5	2
70-6300	Ring	60	6	1	71-0250	Foam - Hood Top	43	2	1
70-6310	Ring	60	10	1	71-0260	Foam - Hood Side L.H.	43	3	1
70-6320	Wheel	60	5	1	71-0270	Foam - Hood Side R.H.	43	1	1
70-6330	Nut	60	4	1	71-0280	Foam - Cowl Top	42	3	1
70-6340	Cover	60	3	1	71-0290	Foam - Cowl Bottom	42	29	1
70-6350	Ring	60	20	1	71-0300	Foam - Low Front Cowl L.H.	42	17	1
70-6360	Plate	60	2	1	71-0310	Foam - Low Front Cowl R.H.	42	*	1
70-6370	Bearing	60	14	2	71-0320	Foam - Low Rear Cowl R.H.	42	*	1
70-6380	Bearing	60	12	1	71-0330	Foam - Low Rear Cowl L.H.	42	30	1
70-6390	Ring	60	15	2	71-0340	Foam - Rad. Support L.H.	44	36	1
70-6400	Ring	60	18	1	71-0350	Foam - Rad. Support R.H.	44	1	1
70-6410	Sleeve	60	11	1	71-0360	Foam - Rad. Support Top	44	3	1
70-6420	Ring	60	13	1	71-0370	Foam - Lower Rad. Support	44	34	2
70-6430	Turbocharger Assembly	59	12	1	71-0380	Foam - Rad. Support Front	44	42	1
70-6440	Cartridge Assembly	60	*	1	71-0390	Foam - Rad. Support Rear	44	44	1
70-6450	Housing	60	16	1	71-0400	Foam - Side Panel	43	14	2
70-6460	Bearing Housing Assembly	60	22	1	71-0410	Cover - Abrasive	10	4	1
70-6470	Shaft & Turbine Wheel Assy.	60	19	1	71-0420	Floor - Abrasive	28	66	1
70-6480	Pin	66	15	1	71-0430	Cover - Abrasive	28	64	1
70-6490	Ring	67	66	1	71-0440	Abrasive - Pedal Front	9	25	1
70-6500	O-Ring	66	37	1	71-0450	Abrasive - Pedal Rear	9	29	1
70-6510	O-Ring	66	22	2	71-0470	Disc - Middle	32	19	4
70-6520	Bolt	66	10	1	71-0480	Suspension Assembly	3	*	1
70-6520	Bolt & Washer	66	29	3	71-0540	Column - Steering	4	27	1
70-6530	Bolt	66	7	5	71-2170	Pin	3	22	1
70-6540	Bolt	65	32	4	71-2180	Bearing	3	2	4
70-6550	Bolt	66	9	1	71-2190	Pin	3	3	1
70-6560	Nut	67	72	2	71-2200	Bracket - Swing Arm	3	33	1
70-6570	Washer - 0.1	67	61	A/R	71-2210	Pin	3	13	1
70-6580	Washer - 0.25	67	*	A/R	71-2220	Pin	3	16	1
70-6590	Washer - 0.5	67	*	A/R	71-2230	Ring - Snap	3	14	1
70-6600	Washer - 0.2	67	*	A/R	71-2240	Knob Assembly	3	15	1
70-6610	Washer - 0.2	67	65	A/R	71-2250	Bracket - Spring	3	18	1
70-6620	Washer - 0.3	67	*	A/R	71-2260	Spring	3	27	2
70-6630	Washer - 0.4	67	*	A/R	71-2270	Nut - Special	3	23	1
70-6640	Washer - 0.1	67	*	A/R	71-2280	Band - Weight Indicator	3	10	1
70-6650	Washer - 1.0	67	*	A/R	71-2290	Bearing - Triple	3	4	1
70-6660	Washer - 1.0	67	*	A/R	71-2300	Bumper	3	9	2
70-6670	Washer	67	70	1	71-2310	Plate - Lower Suspension	3	8	1
70-6680	Washer	65	34	1	71-2320	Pin	3	21	2
70-6690	Washer	66	35	2	71-2330	Ring - Snap	3	19	2
70-6700	Washer	68	16	1	71-2340	Absorber - Shock	3	20	1
70-6710	Washer	66	4	1	71-2380	Washer	2	7	2
70-6720	Stud	65	27	3	71-2390	Rivet - Pop	2	8	2
70-6730	Bolt	66	42	1	71-2400	Assembly - Bumper	2	6	2
70-6740	Bolt	66	26	2	71-2410	Plate - Upper Suspension	2	5	1
70-6750	Bolt	66	41	4	71-2420	Bellows - Rubber	2	12	1
70-6760	Bolt & Washer	66	39	2	71-2430	Plate - Rear	11	16	1

*Not Illustrated

TORO PART NUMBER INDEX (Cont.)

3317-640

Part No.	Description	Pg. No.	Ref. No.	Qty.	Part No.	Description	Pg. No.	Ref. No.	Qty.
71-2450	Cover - Access	27	24	1	76-1670	Spring - Extension	78	33	1
71-2460	Plate - Control	14	5	1	76-1670	Spring - Extension	81	36	1
71-2470	Rim	32	29	2	76-1880	10 Segmented Tire Assy.	94	3	1
71-2530	Bearing Assembly	93	6	1	76-1890	13 Segmented Tire Assy.	94	5	1
71-2550	Washer - Latch Shaft	88	9	2	76-2060	V-Belt	83	*	1
71-2560	Support - Bulkhead	30	38	2	76-2060	V-Belt	84	*	1
71-2570	Shaft - Pivot	78	3	1	76-2060	V-Belt	91	*	6
71-2580	Shaft - Lift Arm Pivot	85	26	2	76-2750	Hydraulic Hose Assembly	81	2	1
71-2590	Shaft - Pivot	75	5	1	76-2760	Hydraulic Hose Assembly	81	1	1
71-2590	Shaft - Pivot	78	24	1	76-2770	Hydraulic Hose Assembly	81	6	1
71-2600	Tube - Anti - Sway	89	11	2	76-4590	Screw	34	16	6
71-2610	Shaft - Deck Pivot	90	15	2	76-4590	Screw	40	27	6
71-2620	Shaft - Lift Arm Elbow	89	23	2	76-4600	Gasket - Cover	40	38	1
71-2630	Solenoid Valve Assembly	28	*	1	76-4600	Gasket - Front Cover	34	26	1
71-2680	Hose - Vent	23	31	1	76-4610	Cover	40	33	1
71-2680	Hose - Vent	45	53	1	76-4610	Cover - Front	34	15	1
71-2690	Hose - Fuel	70	7	1	76-8750	Plate - Caution	44	45	2
71-3810	Coupling - Hydraulic Motor	32	34	2	77-0950	Washer - Castor	90	41	8
71-3830	Bellcrank - Brake	36	21	2	77-2830	Rod - Spring	81	44	1
71-3850	Cover - Housing	36	15	2	77-2990	Cable - Throttle	18	8	1
71-3860	Clevis	36	28	2	77-5390	Tank - Hydraulic	23	4	1
71-3870	Gasket	36	14	2	80-0010	Tank - Fuel	22	11	1
71-3880	Clevis - Brake Cable	32	15	2	80-0130	Cable - Negative	72	11	1
71-3880	Clevis - Brake Cable	36	23	2	80-0160	Tray - Battery	72	18	1
71-3900	Gasket	36	25	2	80-4890	Decal - Service	11	32	1
71-3910	Collar	36	34	2	80-9330	Alarm - Audio	11	3	1
71-3990	Cap - Brake Housing	32	20	2	82-2560	Decal - Belt Routing	81	39	1
71-4010	Housing - Brake	32	13	2	82-4910	Roller	83	27	1
71-4060	Rod - Brake Latch	4	40	1	82-4910	Roller	84	36	1
71-4130	Support - Control	11	17	1	82-6330	Cowl - Radiator, Optional	42	*	1
71-4170	Switch - Toggle	14	19	1	82-7820	Seat - Brake, Tube	36	13	2
71-4200	Cluster - Warning Light	13	6	1	82-7830	Screw - Bleed, Brake	36	11	2
71-4210	Cluster - Warning Light	13	4	1	82-7840	Piston - Brake	36	7	2
71-4230	Panel	13	3	1	82-7850	Spring - Compression	36	4	2
71-4250	Spacer	13	20	2	82-7900	Shaft - Arm	89	34	2
71-4260	Decal - H.O.C.	91	28	2	82-7930	Arm - Anti-Sway L.H.	89	14	1
71-4260	Decal - H.O.C.	82	56	1	82-7940	Arm - Anti-Sway R.H.	89	*	1
71-4280	Sending Unit - Oil Pressure	47	61	1	82-9060	Track & Latch - Adjustment	2	4	1
72-4070	Decal - Danger	33	47	2	83-4330	Assy. - Tube, Traction LH	28	82	1
72-4080	Decal - Danger	72	37	1	83-4330	Tube - Hydraulic L.H.	32	8	1
72-4080	Decal - Danger	28	71	2	83-4340	Assy. - Tube, Traction RH	28	83	1
72-4310	Switch - Ball	78	11	1	83-4340	Tube - Hydraulic R.H.	32	*	1
72-4310	Switch - Lift	85	32	2	83-6630	Shim - Switch	1	5	1
72-9550	Stud - Fuel Tank	22	17	1	83-6640	Sensor - Switch	1	8	1
72-9760	Switch	14	15	2	83-6660	Support - Seat	2	11	1
74-0720	Tube - Manual	2	1	1	83-6690	Plate - Seat	1	15	1
74-2170	Cylinder - Lift	86	43	2	83-6700	Plate - Suspension	1	9	1
74-2180	Ring - Steel	87	9	1	83-8350	Fitting - Traction, L.H.	27	20	1
74-2190	Cushion	87	10	1	83-8360	Fitting - Traction, R.H.	28	73	1
74-2200	Head	87	4	1	83-8370	Plate - Clamp	28	74	1
74-2210	Piston	87	12	1	85-4750	Display - Diagnostic	12	2	1
74-2220	Collar	87	2	1	85-6140	Spring	1	16	1
74-2230	Shaft/Clevis	87	1	1	85-6150	Tube - Hyd. R.H. Branch	32	*	1
74-2270	Fitting - Suction	25	23	1	85-6150	Tube - Hydraulic	27	30	1
74-2340	Decal - Fuse	14	22	1	85-6160	Pin - Spring	1	10	1
74-2510	Tube - Hydraulic L.H.	7	13	1	85-6190	Link - Deck Tilt	27	1	1
74-2520	Tube - Hydraulic R.H.	7	14	1	85-6210	Bracket - Rear Eng. Mount	46	37	2
74-2530	Tube - Hydraulic	7	11	1	85-6230	Assembly - Solenoid Valve	71	*	1
74-2660	Hose - Hydraulic Return	24	34	1	85-6230	Solenoid - Engine Run	46	45	1
74-2680	Bracket - Bulkhead	86	45	1	85-6260	Level Sensing Unit	23	3	1
74-2700	Rod - Control	9	16	1	85-6280	Spring - Return	71	3	1
74-2710	Clamp Half - Hydraulic Line	89	2	4	85-6290	Boot - Rubber	71	2	1
74-2730	Tube - Clamp	89	31	4	85-6300	Assembly - Plunger	71	1	1
74-2750	Retainer - Clamp	89	32	2	86-7350	Seal Repair Kit	87	*	1
75-0540	Tether - Cap, Reservoir	23	27	1	86-7350	Seal Repair Kit	79	*	1
75-2080	Kit - Seal	21	2	2	86-7410	Plate - Gage	13	5	1
75-9460	Bracket - Sealing L.H.	42	19	1	86-7480	Spring - Compression	81	48	1
75-9470	Bracket - Sealing R.H.	42	25	1	86-8100	Joint - Ball	88	19	2
75-9480	Bracket - Sealing Bottom	42	22	1	86-8100	Joint - Ball	78	37	2
75-9670	Fork - Castor	90	32	8	86-8101	Joint - Ball	88	22	2
75-9790	Arm - Pivot	80	10	2	88-6760	Spring - Gas	43	19	2
76-0980	Pipe - Exhaust	46	10	1	88-6770	Stud - Ball	43	18	2
76-1670	Spring - Extension	84	25	1	88-6770	Stud - Ball	45	56	2

*Not Illustrated

TORO PART NUMBER INDEX (Cont.)

Part No.	Description	Pg. No.	Ref. No.	Qty.	Part No.	Description	Pg. No.	Ref. No.	Qty.
88-9190	Solenoid Coil Assembly	73	23	3	93-7039	Bracket - Service Brake	7	21	1
88-9260	Bracket - Roller RH	84	38	1	93-7176	Fitting - 45° ORFS	33	48	2
88-9270	Bracket - Roller LH	83	29	1	93-7177	Assy. - Tube, Traction L.H.	27	19	1
88-9420	Wire Harness Assembly	11	*	1	93-7177	Tube - Hydraulic, LH	33	50	1
88-9430	Decal - Fuse	11	5	1	93-7178	Assy. - Tube, Traction R.H.	27	21	1
88-9450	Bracket - Hood Cylinder	44	37	2	93-7178	Tube - Hydraulic, RH	33	*	1
92-1179	Cushion - Seat	1	17	1	93-7179	Tube - Hydraulic	30	27	1
92-1180	Assembly - Seat	1	1	1	93-7187	Yoke - Engine End	37	8	1
92-1741	Tube - Hydraulic	32	42	1	93-7188	Shaft - Slip Yoke	37	6	1
92-1742	Tube - Hydraulic	24	40	1	93-7189	Yoke - Pump End	37	3	1
92-1742	Tube - Hydraulic L.H.	32	12	1	93-7190	Kit - Universal Joint	37	7	2
92-1753	Coupling - Spring Centering	46	26	1	93-7191	Tube - Slip Yoke	37	4	1
92-1771	Board - Instrument	13	16	1	93-7192	Hose - Diagnostic	28	81	1
92-1772	Hood Assembly	43	4	1	93-7192	Hose - Hydraulic Diagnostic	21	25	1
92-1792	Repair Kit	77	*	1	93-7193	Hose - Diagnostic	28	70	1
92-2351	Fitting - Tank Return	24	36	1	93-7193	Hose - Hydraulic Diagnostic	29	7	1
92-2352	Hose - Hydraulic	24	35	1	93-7417	Gasket	36	33	2
92-2362	Castor Wheel Assembly	80	23	2	93-7418	Cap - Actuator	36	36	2
92-3047	Valve - Solenoid	28	62	1	93-7422	Hose - Hydraulic	27	11	1
92-3048	Solenoid Coil Kit	28	54	3	93-7422	Hose - Hydraulic Diagnostic	29	5	1
92-3049	Valve Seal Kit	28	*	1	93-7423	Hose - Diagnostic	73	44	2
92-3071	Spool - Solenoid Valve	73	25	3	93-7423	Hose - Hydraulic Diagnostic	29	9	2
92-4087	Decal - Diagnostic V2.0	12	1	1	93-7424	Hose - Diagnostic	28	69	1
92-4094	Roller - Latch	88	16	4	93-7424	Hose - Hydraulic	37	50	1
92-4804	Block - Latch Pivot	88	11	2	93-7425	Hose - Hydraulic Diagnostic	29	10	1
92-4805	Cam - Spring Trip	88	21	2	93-7426	Tube - Hydraulic	27	39	1
92-4806	Pin - Latch	78	30	1	93-7426	Tube - Hydraulic	78	44	1
92-4806	Pin - Latch	88	13	8	93-7427	Tube - Hydraulic	78	47	1
92-4807	Tube - Hyd. R.H. Run	32	*	1	93-7634	Cover - Front	92	4	1
92-4807	Tube - Hydraulic	24	4	1	93-7637	Key - Square	92	13	1
92-4967	Tube - Hydraulic	27	9	1	93-7639	Cover - Rear	92	11	1
92-4967	Tube - Hydraulic	21	17	1	93-7640	Section - Center	92	9	1
92-4970	Hose - Hydraulic	23	37	1	93-7641	Gear - Drive	92	12	1
92-4970	Hose - Hydraulic	28	80	1	93-7642	Gear - Driven	92	10	1
92-4971	Hydraulic Cylinder Assembly	78	7	2	93-8457	Hex.-Belt - Deck Drive	82	*	1
92-4997	Cable - Positive	72	12	1	93-8493	Kit - Seal	92	*	1
92-5720	Controller	11	22	1	93-9320	Plate - Valve L.H.	40	40	1
92-7301	Spacer	1	19	2	93-9321	Plug - Orifice	41	75	1
92-8003	Housing - Actuator, R.H.	36	12	1	93-9322	Variable Displacement Pump	37	1	1
92-8004	Housing - Actuator, L.H.	36	*	1	93-9324	Pivot - Idler	84	41	1
92-8661	Tab	11	34	3	93-9324	Pivot - Idler	82	61	1
92-8664	Lift Arm Assembly L.H.	85	33	1	93-9337	Bracket - Switch	7	28	1
92-8665	Lift Arm Assembly R.H.	85	*	1	93-9337	Bracket - Switch	37	35	1
92-8753	Catch - Magnetic	1	6	1	93-9912	Grommet	89	30	2
92-9701	Shaft - Cruise Control	9	3	1	93-9917	Asm. - Hose, Hydraulic	91	9	2
92-9730	Cap - End	5	18	1	93-9918	Asm. - Hose, Hydraulic	91	8	2
92-9732	Plate - Wear	5	14	1	93-9919	Asm. - Hose, Hydraulic	91	29	2
92-9735	Screw - Cap	5	19	7	93-9922	Spacer	86	61	2
92-9748	Valve - Power Steering	4	28	1	93-9925	Lift Arm Assembly R.H.	89	*	1
92-9749	Seal Kit	5	*	1	93-9926	Lift Arm Assembly L.H.	89	25	1
92-9800	Spacer - Spindle	93	11	1	93-9928	Clamp - Hose	89	28	2
93-0307	Nut - Retainer	76	53	2	93-9941	Arm - Outer Lift R.H.	89	*	1
93-0309	Washer	75	25	2	93-9942	Arm - Outer Lift L.H.	89	10	1
93-0310	Spindle - Wheel R.H.	75	*	1	93-9988	Fitting - Hydraulic	28	61	1
93-0311	Spindle - Wheel L.H.	75	17	1	213-31	Cover - Steering Wheel	4	8	1
93-1397	Valve - Flow Control	78	46	1	217-116	Rim	75	23	2
93-3102	Cap - Fuel	22	10	1	218-242	Switch - Brake	7	25	1
93-3103	Cap - Hydraulic	23	36	1	218-243	Fitting - Tee	7	12	1
93-3219	Pump Drive Shaft Assembly	38	*	1	218-446	Nut - Hex	14	9	1
93-3681	Cover	53	1	1	218-447	Washer - Lock	14	8	1
93-3682	Gasket	53	2	1	218-498	Nut	13	18	2
93-4237	Bearing	80	14	4	218-498	Nut - Hex	14	7	10
93-4237	Bearing	90	29	16	218-533	Lens - Indicator Light (Red)	4	7	1
93-4240	10" Wheel - Pneumatic	90	30	8	218-535	Nut - Hex.	4	24	3
93-4240	10" Wheel - Pneumatic	80	12	2	218-536	Washer - Lock	4	23	3
93-4241	Spacer	80	13	2	218-562	Lens - Indicator Light	4	11	2
93-4241	Spacer	90	28	8	218-573	Fuse - 5A	11	*	1
93-4363	Motor - Hydraulic	81	11	1	218-581	Fuse - 15A	11	33	6
93-4363	Motor - Hydraulic	91	13	2	219-17	Bulb - Light	13	9	8
93-4382	Bracket - Muffler	46	18	1	2116-3	Joint - Ball L.H.	75	*	1
93-7037	Switch	7	22	1	2116-4	Joint - Ball R.H.	75	35	1
93-7037	Switch	38	61	1	231-140	Tire - (Optional)	32	*	2
93-7038	Switch	28	77	1	232-27	Stem - Valve	75	29	2

*Not Illustrated

TORO PART NUMBER INDEX (Cont.)

3317-640

Part No.	Description	Pg. Ref.		Part No.	Description	Pg. Ref.	
		No.	Qty.			No.	Qty.
233-17	Knob	4	3 1	237-146	Seal - O-Ring	37	19 3
233-42	Knob	19	3 3	237-154	Seal - O-Ring	70	10 1
233-48	Knob	18	3 1	237-155	Seal - O-Ring	24	20 1
233-66	Knob	14	10 1	237-156	Seal - O-Ring	21	13 8
237-21	Seal - O-Ring	32	3 2	237-156	Seal - O-Ring	73	30 30
237-21	Seal - O-Ring	21	6 2	237-157	Seal - O-Ring	23	16 1
237-21	Seal - O-Ring	30	29 4	237-158	Seal - O-Ring	32	21 4
237-21	Seal - O-Ring	76	52 4	237-164	Grommet	30	7 1
237-21	Seal - O-Ring	28	58 3	237-174	O-Ring	36	9 2
237-22	Seal - O-Ring	27	32 7	237-175	O-Ring	36	6 2
237-22	Seal - O-Ring	81	7 1	240-2	Grommet	30	6 2
237-22	Seal - O-Ring	78	8 9	240-3	Grommet	85	8 4
237-22	Seal - O-Ring	91	10 2	240-4	Grommet	27	6 6
237-22	Seal - O-Ring	19	14 9	240-4	Grommet	85	18 10
237-22	Seal - O-Ring	44	17 2	240-5	Grommet	27	28 2
237-22	Seal - O-Ring	85	19 14	240-6	Grommet	30	31 4
237-22	Seal - O-Ring	21	21 7	240-7	Grommet	30	32 1
237-22	Seal - O-Ring	23	21 2	240-7	Grommet	28	47 4
237-22	Seal - O-Ring	4	37 4	2410-10	Plug - Button	28	72 1
237-22	Seal - O-Ring	75	45 6	2410-73	Pin - Tether	23	35 1
237-22	Seal - O-Ring	47	56 2	2411-40	Joint - Ball	89	13 4
237-22	Seal - O-Ring	41	64 1	2411-41	End - Rod	46	52 2
237-22	Seal - O-Ring	24	5 3	2412-3	Clamp - Hose	23	15 1
237-30	Seal - O-Ring	27	8 3	2412-6	Clamp - Hose	70	2 2
237-30	Seal - O-Ring	24	13 2	2412-6	Clamp - Hose	44	6 1
237-30	Seal - O-Ring	37	17 2	2412-6	Clamp - Hose	22	15 1
237-30	Seal - O-Ring	21	22 2	2412-7	Clamp Assembly	75	38 2
237-37	Bumper - Rubber	72	34 4	2412-34	Clamp - Hose	23	11 1
237-42	Seal - O-Ring	32	1 2	2412-39	Clamp	72	39 1
237-42	Seal - O-Ring	78	6 4	2412-39	Clamp - R	47	68 1
237-42	Seal - O-Ring	73	7 1	2412-41	Clamp	72	38 2
237-42	Seal - O-Ring	91	12 2	2412-41	Clamp - R	44	38 1
237-42	Seal - O-Ring	37	23 1	2412-41	Clamp - R	47	59 2
237-42	Seal - O-Ring	19	24 5	2412-42	Clamp - Hose	25	11 4
237-42	Seal - O-Ring	21	27 6	2412-42	Clamp - Hose	23	13 4
237-42	Seal - O-Ring	86	42 4	2412-42	Clamp - Hose	46	19 1
237-42	Seal O-Ring	81	9 1	2412-70	Clamp - R	46	3 1
237-58	Seal - O-Ring	27	14 4	2412-73	Clamp - R	72	7 3
237-58	Seal - O-Ring	25	2 2	2412-73	Clamp - R	47	69 1
237-58	Seal - O-Ring	81	3 2	2412-89	Clamp - R	22	9 1
237-58	Seal - O-Ring	24	7 1	2412-92	Clamp - Hose	24	9 4
237-58	Seal - O-Ring	32	7 7	2412-92	Clamp - Hose	44	11 4
237-58	Seal - O-Ring	73	10 8	2412-104	Clamp-R	72	40 1
237-58	Seal - O-Ring	37	21 3	2412-108	Clamp - Hose	70	6 1
237-65	O-Ring	33	49 2	2412-108	Clamp - Hose	23	32 2
237-65	Seal - O-Ring	24	3 2	2412-108	Clamp - Hose	45	52 2
237-65	Seal - O-Ring	91	7 4	2412-110	Clamp - Hose	46	16 3
237-65	Seal - O-Ring	27	18 6	2412-129	Clamp - Hose	24	39 1
237-65	Seal - O-Ring	85	20 4	2412-133	Clamp	2	2 2
237-78	Seal - O-Ring	27	13 5	2412-147	Clamp - R	44	48 1
237-78	Seal - O-Ring	21	8 3	250-5	Tie - Cable	42	34 16
237-78	Seal - O-Ring	73	33 1	251-259	Bearing - Neutral Detent	37	41 1
237-78	Seal - O-Ring	73	41 2	251-321	Bearing - Ball	94	1 2
237-78	Seal - O-Ring	75	43 4	251-321	Bearing - Castor	80	22 4
237-78	Seal - O-Ring	21	4 2	251-332	Spacer - Inner	94	4 1
237-79	Seal - O-Ring	19	12 2	251-333	Spacer - Bearing	80	21 2
237-79	Seal - O-Ring	23	23 1	251-333	Spacer - Inner	94	6 1
237-79	Seal - O-Ring	21	24 2	251-340	Bearing - Ball	32	23 2
237-79	Seal - O-Ring	73	32 4	253-154	Seal - Wave	93	5 2
237-79	Seal - O-Ring	4	39 4	253-156	Seal - Oil	32	22 2
237-80	Seal - O-Ring	24	1 1	253-157	Ring - Cup	32	41 8
237-80	Seal - O-Ring	23	19 3	254-72	Cup - Bearing Outer	75	20 2
237-80	Seal - O-Ring	41	68 1	254-92	Cone - Bearing Outer	75	21 2
237-81	Seal - O-Ring	23	1 1	254-106	Cone - Bearing Inner	75	31 2
237-81	Seal - O-Ring	81	5 2	254-107	Cup - Bearing Inner	75	30 2
237-81	Seal - O-Ring	91	5 4	256-76	Bushing - Sleeve	89	15 4
237-81	Seal - O-Ring	32	9 4	256-117	Bushing - Flange	81	28 4
237-81	Seal - O-Ring	37	15 1	256-156	Bushing - Flange	9	30 2
237-81	Seal - O-Ring	73	19 8	256-172	Bearing - Sleeve	88	15 8
237-101	Seal - O-Ring	24	24 2	256-188	Bushing - Sleeve	84	6 1
237-116	Seal - O-Ring	25	9 1	256-188	Bushing - Sleeve	81	22 1
237-146	Seal - O-Ring	32	5 4	256-247	Bushing - Flange	6	1 4
237-146	Seal - O-Ring	73	14 1	256-247	Bushing - Flange	28	46 2

*Not Illustrated

TORO PART NUMBER INDEX (Cont.)

Part No.	Description	Pg. No.	Ref. No.	Qty.	Part No.	Description	Pg. No.	Ref. No.	Qty.
256-273	Bushing - Flange	9	28	1	322-6	Screw - Cap Hex. Hd.	44	40	4
256-304	Washer - Thrust	89	6	8	322-11	Screw - Cap Hex. Hd.	85	1	1
256-304	Washer - Thrust	75	7	6	322-11	Screw - Cap Hex. Hd.	72	30	1
256-304	Washer - Thrust	78	28	2	322-12	Screw - Cap Hex. Hd.	30	9	4
256-304	Washer - Thrust	85	29	4	322-12	Screw - Cap Hex. Hd.	24	44	3
256-304	Washer - Thrust	90	40	4	322-13	Screw - Cap Hex. Hd.	47	76	1
256-305	Washer - Thrust	83	16	2	322-17	Screw - Cap Hex. Hd.	37	39	1
256-305	Washer - Thrust	84	24	2	322-21	Screw - Cap Hex. Hd.	30	23	3
282-2	Clevis - Brake Rod	7	18	1	323-4	Screw - Cap Hex. Hd.	11	4	4
282-28	Clevis - Adjustable	18	6	2	323-4	Screw - Cap Hex. Hd.	6	21	4
283-1	Pin - Clevis	6	24	2	323-4	Screw - Cap Hex. Hd.	72	21	4
283-1	Pin - Clevis	7	24	1	323-4	Screw - Cap Hex. Hd.	43	25	2
283-2	Pin - Clevis	32	16	2	323-4	Screw - Cap Hex. Hd.	24	28	3
283-2	Pin - Clevis	36	24	2	323-4	Screw - Cap Hex. Hd.	47	70	4
283-15	Pin - Clevis	36	31	2	323-6	Screw - Cap Hex. Hd.	75	3	2
283-67	Pin - Clevis Arm End	18	5	1	323-6	Screw - Cap Hex. Hd.	83	6	3
283-70	Pin - Hitch	80	9	2	323-6	Screw - Cap Hex. Hd.	2	9	2
283-72	Pin - Lynch	1	3	1	323-6	Screw - Cap Hex. Hd.	85	12	4
285-17	Plug - Pipe	41	76	2	323-6	Screw - Cap Hex. Hd.	25	18	4
2812-4	Fitting - Reducer	44	15	2	323-6	Screw - Cap Hex. Hd.	32	18	14
302-2	Fitting - Grease	85	31	4	323-6	Screw - Cap Hex. Hd.	84	19	3
302-2	Fitting - Grease	78	2	4	323-6	Screw - Cap Hex. Hd.	43	23	4
302-2	Fitting - Grease	84	4	1	323-6	Screw - Cap Hex. Hd.	9	31	1
302-2	Fitting - Grease	89	4	4	323-6	Screw - Cap Hex. Hd.	72	32	4
302-2	Fitting - Grease	37	5	1	323-6	Screw - Cap Hex. Hd.	47	60	1
302-2	Fitting - Grease	90	13	2	323-7	Screw - Cap Hex. Hd.	37	51	2
302-2	Fitting - Grease	81	20	1	323-7	Screw - Cap Hex. Hd.	25	4	8
302-2	Fitting - Grease Str.	93	1	1	323-7	Screw - Cap Hex. Hd.	7	7	3
302-5	Fitting - Grease	77	1	1	323-7	Screw - Cap Hex. Hd.	4	16	4
302-5	Fitting - Grease	94	2	1	323-7	Screw - Cap Hex. Hd.	83	31	3
302-5	Fitting - Grease	6	3	2	323-7	Screw - Cap Hex. Hd.	84	39	3
302-5	Fitting - Grease	79	13	3	323-7	Screw - Cap Hex. Hd.	44	41	4
302-5	Fitting - Grease	75	15	3	323-9	Screw - Cap Hex. Hd.	72	13	2
302-5	Fitting - Grease	87	15	2	323-9	Screw - Cap Hex. Hd.	1	22	2
302-5	Fitting - Grease	88	18	2	323-10	Screw - Cap Hex. Hd.	23	5	4
302-5	Fitting - Grease	89	22	2	323-15	Screw - Cap Hex. Hd.	80	17	16
302-5	Fitting - Grease	80	27	4	323-15	Screw - Cap Hex. Hd.	90	23	32
302-5	Fitting - Grease	81	33	4	323-15	Screw - Cap Hex. Hd.	86	44	2
302-5	Fitting - Grease	90	34	8	323-21	Screw - Cap Hex. Hd.	22	6	1
302-5	Fitting - Grease	78	40	2	323-34	Screw - Cap Hex. Hd.	44	8	7
302-5	Fitting - Grease	28	48	1	325-4	Screw - Cap Hex. Hd.	46	46	4
302-10	Fitting - Grease 45°	93	*	1	325-5	Screw - Cap Hex. Hd.	4	30	3
302-33	Fitting - Grease	75	36	2	325-6	Screw - Cap Hex. Hd.	25	20	4
302-39	Vent	32	25	2	325-6	Screw - Cap Hex. Hd.	78	22	12
302-40	Fitting - Grease	88	23	2	325-6	Screw - Cap Hex. Hd.	44	43	2
304-46	Drain - Fuel Tank	22	13	1	325-6	Screw - Cap Hex. Hd.	75	46	12
304-46	Valve - Drain	44	14	1	325-7	Screw - Cap Hex. Hd.	37	12	2
321-2	Screw - Cap Hex. Hd.	42	4	16	325-7	Screw - Cap Hex. Hd.	81	16	1
321-2	Screw - Cap Hex. Hd.	6	10	1	325-7	Screw - Cap Hex. Hd.	33	46	4
321-2	Screw - Cap Hex. Hd.	36	17	8	325-8	Screw - Cap Hex. Hd.	84	8	1
321-2	Screw - Cap, Hex. Hd.	23	26	1	325-8	Screw - Cap Hex. Hd.	81	24	1
321-3	Screw - Cap Hex. Hd.	72	3	3	325-15	Screw - Cap Hex. Hd.	80	6	4
321-3	Screw - Cap Hex. Hd.	9	6	4	325-17	Screw - Cap Hex. Hd.	46	43	4
321-3	Screw - Cap Hex. Hd.	18	10	3	325-20	Screw - Cap Hex. Hd.	90	3	8
321-3	Screw - Cap Hex. Hd.	11	14	4	327-17	Screw Cap Hex. Hd.	90	26	8
321-4	Screw - Cap Hex. Hd.	6	5	1	327-22	Screw - Cap Hex. Hd.	32	27	16
321-4	Screw - Cap Hex. Hd.	37	42	2	327-24	Screw Cap Hex. Hd.	80	15	2
321-4	Screw - Cap Hex. Hd.	46	51	2	327-25	Screw - Cap Hex. Hd.	80	20	2
321-5	Screw - Cap Hex. Hd.	23	10	10	327-80	Seal - O-Ring	37	53	2
321-6	Screw - Cap Hex. Hd.	36	37	8	328-8	Screw - Cap Hex. Hd.	85	36	4
321-6	Screw - Cap Hex. Hd.	46	38	3	328-8	Screw - Cap Hex. Hd.	85	37	2
321-9	Screw - Cap Hex. Hd.	30	22	6	328-10	Screw - Cap Hex. Hd.	78	21	2
321-9	Screw - Cap Hex. Hd.	28	43	2	328-11	Screw - Cap Hex. Hd.	42	26	2
321-9	Screw - Cap Hex. Hd.	86	56	3	328-24	Screw - Cap Hex. Hd.	86	58	4
321-10	Screw - Cap Hex. Hd.	19	1	2	328-26	Screw - Cap Hex. Hd.	85	28	12
321-10	Screw - Cap Hex. Hd.	37	47	2	3210-7	Screw - Cap Hex. Hd.	37	40	1
321-11	Screw - Cap Hex. Hd.	28	65	2	3213-2	Screw - Cap Hex. Hd.	25	22	4
321-15	Screw - Cap Hex. Hd.	89	3	4	3217-7	Nut - Hex.	22	19	1
321-15	Screw - Cap Hex. Hd.	30	18	2	3217-7	Nut - Hex.	37	34	1
322-3	Screw - Cap Hex. Hd.	7	5	2	3217-7	Nut - Lock	9	1	1
322-3	Screw - HH	89	27	4	3217-9	Nut - Hex.	37	14	2
322-5	Screw - Cap Hex Hd.	72	27	1	3217-9	Nut - Hex.	78	26	16
322-5	Screw - Cap Hex. Hd.	44	39	1	3217-9	Nut - Jam	81	37	2

*Not Illustrated

TORO PART NUMBER INDEX (Cont.)

3317-640

Part No.	Description	Pg. No.	Ref. No.	Qty.	Part No.	Description	Pg. No.	Ref. No.	Qty.
3217-26	Nut - Lock	9	7	1	3253-9	Washer - Lock	89	20	4
3219-2	Nut - Hex.	37	29	1	3253-15	Washer - Lock	22	20	5
3219-5	Nut - Hex.	32	31	18	3253-15	Washer - Lock	14	21	A/R
3219-7	Nut - Lock	89	19	4	3253-21	Washer - Lock	9	2	2
3219-10	Nut - Jam	73	24	3	3253-21	Washer - Lock	22	5	2
3219-14	Nut - Hex.	46	1	2	3253-21	Washer - Lock	25	5	8
3219-14	Nut - Hex.	18	7	2	3253-21	Washer - Lock	23	6	4
3219-14	Nut - Hex.	24	17	1	3253-21	Washer - Lock	2	10	2
3220-1	Nut - Jam	46	50	2	3253-21	Washer - Lock	72	14	2
3220-2	Nut - Jam	7	17	1	3253-21	Washer - Lock	32	17	14
3220-3	Nut - Jam	9	21	2	3253-21	Washer - Lock	4	17	4
3220-4	Nut	28	53	1	3253-21	Washer - Lock	11	19	4
3220-4	Nut - Bulkhead	29	12	8	3253-21	Washer - Lock	36	19	8
3220-5	Nut - Jam	9	19	1	3253-21	Washer - Lock	43	22	6
3220-7	Nut - Jam	89	12	4	3253-21	Washer - Lock	24	29	3
3220-7	Nut - Jam	75	28	2	3253-21	Washer - Lock	37	32	3
3220-22	Nut - Jam	88	4	4	3253-21	Washer - Lock	44	35	12
3229-8	Bolt - Carriage	11	35	3	3253-21	Washer - Lock	47	75	4
3230-22	Bolt - Carriage	2	20	1	3254-2	Washer	89	26	4
3231-22	Bolt - Carriage	93	7	6	3254-2	Washer - Lock	72	25	1
3231-25	Bolt - Carriage	84	9	2	3254-6	Washer - Lock	19	25	1
3231-25	Bolt - Carriage	83	20	2	3256-1	Washer - Flat	46	48	1
3231-28	Bolt - Carriage	81	12	2	3256-3	Washer - Flat	47	67	3
3231-28	Bolt - Carriage	91	27	4	3256-5	Washer - Flat	22	7	2
3231-30	Bolt - Carriage	37	33	1	3256-6	Washer - Flat	9	17	1
3233-9	Bolt - Carriage	83	9	3	3256-7	Washer - Flat	1	26	1
3233-9	Bolt - Carriage	90	22	12	3256-22	Washer - Flat	14	2	8
3233-9	Bolt - Carriage	84	30	3	3256-22	Washer - Flat	30	11	2
3233-27	Bolt - Carriage	81	42	1	3256-22	Washer - Flat	11	12	4
3233-28	Bolt - Carriage	90	12	6	3256-22	Washer - Flat	4	44	1
3233-29	Bolt - Carriage	90	11	2	3256-23	Washer	13	2	4
3233-30	Bolt - Carriage	91	22	6	3256-23	Washer - Flat	2	16	4
3233-30	Bolt - Carriage	82	59	1	3256-23	Washer - Flat	30	24	1
3234-5	Screw - Cap Hex. Hd.	1	11	4	3256-23	Washer - Flat	28	68	2
3234-7	Screw - Hex. Washer Hd.	11	2	11	3256-24	Washer - Flat	72	15	2
3234-12	Screw - Hex. Flange Hd.	75	10	2	3256-24	Washer - Flat	93	16	A/R
3234-12	Screw - Hex. Flange Hd.	82	53	4	3256-24	Washer - Flat	43	24	6
3234-12	Screw - Hex. Washer Hd.	91	2	8	3256-24	Washer - Flat	1	27	2
3234-13	Screw - Hex. Flange Hd.	37	36	4	3256-24	Washer - Flat	36	27	4
3234-13	Screw - Hex. Washer Hd.	22	8	1	3256-26	Washer - Flat	18	13	1
3234-13	Screw - Hex. Washer Hd.	7	19	2	3256-26	Washer - Flat	4	29	3
3234-14	Screw - Cap Hex. Hd.	43	11	6	3256-26	Washer - Flat	32	45	4
3234-14	Screw - Cap Hex. Hd.	9	12	1	3256-26	Washer - Flat	47	54	8
3234-14	Screw - Cap Hex. Hd.	6	18	3	3256-27	Washer - Flat	1	24	1
3234-14	Screw - Cap Hex. Hd.	1	23	6	3256-56	Washer - Flat	30	21	8
3234-14	Screw - Cap Hex. Hd.	11	25	2	3256-56	Washer - Flat	85	40	3
3234-14	Screw - Hex. Flange Hd.	30	2	6	3256-56	Washer - Flat	44	47	2
3234-14	Screw - Hex. Flange Hd.	10	5	4	3256-56	Washer - Flat	28	67	2
3234-14	Screw - Hex. Flange Hd.	19	8	6	3256-69	Washer	83	26	2
3234-14	Screw - Hex. Flange Hd.	27	25	4	3256-69	Washer	84	35	2
3234-14	Screw - Hex. Washer Hd.	46	20	4	3258-19	Screw - Machine	46	14	2
3234-14	Screw - Hex. Washer Hd.	4	25	8	3269-6	Washer - Backup	42	33	22
3234-17	Screw - Hex. Flange Hd.	72	6	4	3269-15	Rivet - Pop	42	32	22
3234-28	Screw - Hex. Flange Hd.	27	10	2	3269-25	Rivet - Pop	29	1	4
3245-31	Screw - Set	9	8	1	3269-25	Rivet - Pop	83	1	4
3245-32	Screw - Set	9	26	1	3269-25	Rivet - Pop	84	1	4
3249-11	Screw - Machine	6	26	2	3269-25	Rivet - Pop	91	17	16
3250-27	Screw - Truss Hd.	83	5	2	3269-25	Rivet - Pop	81	29	8
3250-27	Screw - Truss Hd.	84	14	2	3272-1	Pin - Cotter	19	4	6
3253-2	Washer - Lock	24	16	1	3272-1	Pin - Cotter	18	9	3
3253-2	Washer - Lock	44	21	16	3272-5	Pin - Cotter	6	6	1
3253-2	Washer - Lock	47	65	2	3272-5	Pin - Cotter	4	43	1
3253-3	Washer - Lock	23	9	10	3272-6	Pin - Cotter	72	4	1
3253-3	Washer - Lock	11	15	4	3272-6	Pin - Cotter	6	9	2
3253-3	Washer - Lock	36	16	8	3272-6	Pin - Cotter	19	10	2
3253-3	Washer - Lock	37	46	2	3272-6	Pin - Cotter	32	14	2
3253-3	Washer - Lock	47	74	1	3272-6	Pin - Cotter	36	22	2
3253-7	Washer - Lock	37	13	2	3272-6	Pin - Cotter	46	47	1
3253-7	Washer - Lock	25	21	8	3272-7	Pin - Cotter	9	23	2
3253-7	Washer - Lock	78	25	16	3272-7	Pin - Cotter	81	45	1
3253-7	Washer - Lock	32	30	22	3272-10	Pin - Cotter	7	16	1
3253-8	Washer - Lock	93	14	1	3272-10	Pin - Cotter	9	18	1
3253-8	Washer - Lock	32	26	16	3272-10	Pin - Cotter	36	26	2

*Not Illustrated

TORO PART NUMBER INDEX (Cont.)

Part No.	Description	Pg. Ref. No. No. Qty.	Part No.	Description	Pg. Ref. No. No. Qty.
3272-12	Pin - Cotter	88 2 4	32108-103	Screw - Machine Flat Hd.	89 9 4
3272-12	Pin - Cotter	7 6 1	32108-103	Screw - Machine Flat Hd.	85 25 4
3272-12	Pin - Cotter	75 34 6	32108-103	Screw - Machine Flat Hd.	28 40 4
3272-12	Pin - Cotter	78 35 2	32120-22	Ring - Retaining Internal	32 24 2
3272-13	Pin - Cotter	75 26 2	32120-47	Ring - Retaining	78 31 2
3272-23	Pin - Cotter	78 18 4	32120-47	Ring - Retaining	88 14 16
3272-33	Pin - Cotter	85 24 2	32120-64	Ring - Retaining	1 25 2
3274-7	Screw - Cap Socket Hd.	36 18 8	32120-72	Ring - Retaining	84 5 1
3274-20	Screw - Hex. Socket Hd.	37 11 2	32120-72	Ring - Retaining	81 21 1
3274-86	Screw - Cap Socket Hd.	27 15 1	32120-84	Ring - Retaining External	32 33 2
3290-133	Screw - Round Hd.	13 1 4	32121-4	Pin - Roll	1 13 1
3290-133	Screw - Round Hd.	14 3 8	32121-4	Pin - Roll	2 18 1
3290-133	Screw - Round Hd.	11 11 4	32121-4	Pin - Roll	83 28 2
3290-134	Screw - Cap Hex. Hd.	43 13 4	32121-4	Pin - Roll	84 37 2
3290-216	Washer - Bevel	75 9 12	32121-6	Pin - Roll	83 18 2
3290-216	Washer - Bevel	44 25 4	32121-6	Pin - Roll	84 21 2
3290-271	Rivet - Pop	44 46 4	32121-34	Pin - Roll	89 17 2
3290-307	Pin - Cotter, Hair	6 25 2	32121-34	Pin - Roll	77 18 1
3290-321	Screw - Cap Hex. Hd.	43 5 12	32121-49	Pin - Roll	88 17 2
3290-321	Screw - Cap Hex. Hd.	72 20 1	32121-110	Pin - Roll	75 4 1
3290-321	Screw - Cap Hex. Hd.	44 22 16	32121-110	Pin - Roll	90 17 2
3290-321	Screw - Hex. Washer Hd.	42 14 20	32121-110	Pin - Roll	78 23 2
3290-343	Pin - Cotter Hair	80 11 2	32121-110	Pin - Roll	85 27 2
3290-378	Tie - Cable	11 * 25	32121-110	Pin Roll	89 24 4
3290-378	Tie - Cable	6 * 3	32122-24	Screw - Cap Hex. Hd.	22 3 5
3290-378	Tie - Cable	82 * 2	32122-53	Screw - Pan Head	1 7 4
3290-378	Tie - Cable	86 * 3	32122-53	Screw - Phil. Truss Hd.	11 9 2
3290-378	Tie - Cable	91 * 24	32127-11	Nut - Flexlok	7 27 2
3290-378	Tie - Cable	11 18 2	32127-11	Nut - Flexlok	37 37 2
3290-378	Tie - Cable	78 41 1	32128-19	Nut - Lock Flange Hd.	1 21 2
3290-378	Tie - Cable	4 36 5	32128-20	Nut - Flange Lock	44 19 5
3290-384	Pin - Lynch	80 1 2	32128-20	Nut - Flange Lock	4 22 2
3290-384	Pin - Lynch	90 2 8	32128-20	Nut - Flange Lock	11 27 2
3290-392	Screw - HH	14 17 1	32128-20	Nut - Flange Lock	46 30 4
3290-495	Pin - Lynch	27 2 2	32128-20	Nut - Lock	9 13 1
3296-2	Nut - Flange Lock	43 7 12	32128-20	Nut - Lock	6 17 3
3296-2	Nut - Flange Lock	42 12 20	32128-20	Nut - Lock	81 19 4
3296-2	Nut - Flange Lock	72 24 1	32128-20	Nut - Lock	30 37 4
3296-2	Nut - Lock	83 2 6	32128-21	Nut - Flange Lock	37 2 2
3296-2	Nut - Lock	84 10 6	32128-21	Nut - Flange Lock	91 4 12
3296-2	Nut - Lock	13 15 2	32128-21	Nut - Flange Lock	93 9 6
3296-2	Nut - Lock	91 19 16	32128-21	Nut - Flange Lock	81 10 6
3296-2	Nut - Lock	11 21 6	32128-21	Nut - Flange Lock	83 10 6
3296-2	Nut - Lock	81 34 8	32128-21	Nut - Flange Lock	84 22 6
3296-3	Nut - Lock	36 29 2	32128-21	Nut - Lock	7 8 3
3296-9	Nut - Lock	6 14 2	32128-23	Nut - Flange Lock	80 3 4
3296-23	Nut - Lock	18 14 1	32128-23	Nut - Flange Lock	90 7 20
3296-29	Nut - Lock	1 12 4	32128-23	Nut - Flange Lock	83 8 3
3296-29	Nut - Lock	2 17 4	32128-23	Nut - Flange Lock	91 25 6
3296-41	Nut - Lock	88 8 2	32128-23	Nut - Flange Lock	84 26 4
3296-42	Nut - Keps	18 1 3	32128-23	Nut - Flange Lock	4 34 3
3296-42	Nut - Lock	14 4 4	32128-23	Nut - Flange Lock	81 35 4
3296-49	Nut - Lock	93 2 1	32128-23	Nut - Lock	75 8 12
3296-49	Nut - Lock	4 20 1	32128-25	Nut - Lock	25 19 4
3296-53	Nut - Lock	80 16 4	32128-25	Nut - Lock	36 20 2
3296-53	Nut - Lock	90 31 8	32128-43	Nut - Lock	80 19 16
3296-54	Nut - Lock	1 4 4	32128-43	Nut - Lock	90 25 32
3296-59	Nut - Lock	36 35 2	32128-45	Nut - Lock	90 8 8
3296-68	Nut - Lock	78 1 2	32136-2	Nut - Castle	88 1 4
3296-68	Nut - Lock	75 11 1	32136-2	Nut - Castle	75 41 2
3296-68	Nut - Lock	90 14 2	32136-2	Nut - Slotted	78 36 2
3296-68	Nut Lock	85 35 2	32136-13	Nut - Castle	75 33 4
32103-3	Nut - Wing	44 33 2	32144-1	Screw - Hex. Hd.	7 26 2
32104-16	Screw - Tapping	13 7 4	32144-1	Screw - Hex. Hd.	37 30 2
32105-1	Screw - Cap Hex. Hd.	13 17 2	32144-11	Screw - Hex. Flange Hd.	42 21 8
32105-1	Screw - Machine	83 11 4	32144-11	Screw - Thread Forming	86 60 4
32105-1	Screw - Machine	84 16 4	32144-19	Screw - Round Hd.	13 24 4
32105-1	Screw - Machine	81 27 8	32144-64	Screw - Hex. Washer Hd.	4 13 4
32105-1	Screw - Pan Hd.	91 21 16	32144-69	Screw - Cap, Hex. Hd.	45 54 6
32105-12	Screw - Hex. Socket Hd.	11 7 2	32144-96	Screw - Mach. Round Hd.	4 42 3
32105-13	Screw - Hex. Hd.	11 8 4	32149-2	Nut - Keps	42 2 16
32107-11	Nut - Square	46 27 2	32149-2	Nut - Keps	9 4 4
32108-103	Screw - Flat Hd.	81 18 4	32149-2	Nut - Keps	19 7 2

*Not Illustrated

TORO PART NUMBER INDEX (Cont.)

3317-640

Part No.	Description	Pg. No.	Ref. No.	Qty.	Part No.	Description	Pg. No.	Ref. No.	Qty.
32149-2	Nut - Keps	72	8	3	340-65	Seal - O-Ring	44	28	3
32149-2	Nut - Keps	43	16	16	340-68	Fitting - Hydraulic Bulk Tee	78	14	1
32149-2	Nut - Keps	7	20	2	340-68	Fitting - Hydraulic Bulkhead	75	2	2
32149-2	Nut - Keps	46	33	5	340-70	Nut - Bulkhead	27	4	6
32149-2	Nut - Keps	11	36	3	340-70	Nut - Bulkhead	78	13	1
32149-2	Nut - Keps	28	55	2	340-70	Nut - Bulkhead	85	15	10
32149-7	Nut	43	30	4	340-70	Nut - Bulkhead	76	48	2
32149-7	Nut - Keps	11	23	3	340-71	Fitting - Hydraulic Bulkhead	27	7	1
32151-10	Ring - Retaining	75	14	2	340-74	Nut - Bulkhead	85	11	4
32151-10	Ring - Retaining	89	21	2	340-77	Fitting - Hydraulic Elbow	78	19	4
32151-48	Ring - Retaining	80	8	4	340-77	Fitting - Hydraulic Elbow	85	41	4
32151-100	Ring - Retaining	36	2	2	340-78	Nut - Bulkhead	30	34	4
32152-1	Nut	43	31	2	340-79	Fitting - Hydraulic 90°	24	23	1
32152-1	Nut - Lock	7	2	2	340-82	Fitting - Hydraulic Elbow	32	4	2
32152-1	Nut - Lock	85	3	5	340-86	Fitting - Hydraulic Tee	19	15	2
32152-1	Nut - Lock	89	7	4	340-91	Fitting - Hydraulic Straight	32	6	2
32152-1	Nut - Lock	6	12	4	340-92	Fitting - Hydraulic Straight	21	7	2
32152-1	Nut - Lock	30	13	8	340-92	Fitting - Hydraulic	28	56	1
32152-1	Nut - Lock	72	26	3	340-94	Tee - Hydraulic	21	35	1
32152-1	Nut - Lock	27	36	1	340-105	Fitting - Hydraulic Elbow	38	55	1
32152-1	Nut - Lock	24	41	3	340-124	Fitting - Hydraulic Straight	44	16	2
32152-1	Nut - Lock	28	42	4	340-125	Fitting - Hydraulic	28	59	1
32152-1	Nut - Lock	45	57	2	340-126	Nut - Bulkhead	27	3	2
32152-1	Nut - Lock	47	57	2	340-127	Nut - Bulkhead	27	29	2
32152-2	Nut - Lock	85	5	6	340-128	Nut - Bulkhead	30	3	2
32152-2	Nut - Lock	25	16	4	340-129	Fitting - Hydraulic Elbow	73	13	1
32152-2	Nut - Lock	72	22	4	340-130	Fitting - Hydraulic 90°	23	18	1
32152-2	Nut - Lock	44	27	7	340-130	Fitting - Hydraulic Elbow	38	54	1
32152-2	Nut - Lock	76	47	2	340-131	Fitting - Hydraulic Elbow	37	16	1
32152-4	Nut - Lock	89	1	4	340-132	Fitting - Hydraulic Elbow	75	44	4
32152-4	Nut - Lock	30	12	6	340-133	Fitting - Hydraulic Straight	4	32	3
32152-4	Nut - Lock	6	15	2	340-134	Fitting - Hydraulic Elbow	37	48	1
32152-4	Nut - Lock	37	27	2	340-135	Seal - O-Ring	25	7	2
32152-4	Nut - Lock	28	45	2	340-136	Seal - O-Ring	24	37	1
32152-4	Nut Lock	85	23	3	340-142	Fitting - Hydraulic Elbow	81	4	2
32153-3	Nut - Lock	37	44	1	340-142	Fitting - Hydraulic Elbow	73	15	1
32153-5	Nut - Lock	44	26	2	340-142	Fitting - Hydraulic Elbow	32	43	2
32153-5	Nut - Lock	46	41	8	340-148	Fitting - Hydraulic Tee R.H.	32	*	1
32153-6	Nut - Lock	85	4	22	340-150	Cap - Hydraulic	24	38	1
32153-6	Nut - Lock	78	20	2	353-375	Fitting - Hydraulic 90°	27	12	2
32153-6	Nut Lock	42	24	2	353-431	Fitting - Hydraulic 45°	73	42	2
33004-00	Nut - HWH	2	23	2	353-536	Fitting - Fuel 90° Elbow	22	16	1
33015-00	Nut	2	22	2	353-566	Tee - Hydraulic	21	16	1
33104-025	Screw - HHF	2	21	2	353-781	Fitting - Fuel Elbow	70	3	2
340-2	Fitting - Hydraulic Straight	19	23	3	353-947	Cap - Fitting	29	2	8
340-2	Fitting - Hydraulic Straight	21	26	5	353-988	Plug	73	39	4
340-2	Fitting - Hydraulic Straight	91	11	2	353-989	Plug	73	6	1
340-3	Fitting - Hydraulic Straight	19	13	2	353-990	Plug	73	34	1
340-3	Fitting - Hydraulic Straight	23	22	1	353-990	Plug - Hose	21	3	2
340-4	Fitting - Hydraulic Straight	21	23	2	353-991	Plug	73	31	30
340-8	Fitting - Hydraulic Straight	91	6	4	353-991	Plug - Hole	21	12	8
340-9	Fitting - Hydraulic St. L.H.	32	10	1	353-992	Flange - Fitting	25	6	4
340-9	Fitting - Hydraulic Straight	73	18	7	353-994	Adapter	7	10	1
340-15	Fitting - Hydraulic Elbow	37	20	3	353-997	Fitting - Hydraulic Bulkhead	29	3	8
340-22	Fitting - Hydraulic Tee	24	2	1	354-42	Flange - Half	25	10	2
340-57	Fitting - Hydraulic Straight	78	45	2	354-95	Fitting	45	51	1
340-65	Seal - O-Ring	73	12	2	354-104	Ring - Backup	36	5	2
340-65	Seal - O-Ring	24	22	1	354-105	Ring - Backup	36	10	2

*Not Illustrated

TABLE OF CONTENTS

Description	Page	Description	Page
Seat Assembly	1	Water Pump Assembly	51
Seat Pivot & Bellows Assembly	2	Timing Gear Case Assembly	52
Seat Suspension Assembly	3	Rocker Cover & Cylinder Head Assembly	53
Steering Tower Assembly	4	Valve & Camshaft Assembly	54
Power Steering Valve Assembly No. 92–9748	5	Crankcase Assembly	55
Steering Brake Assembly	6	Piston, Connecting Rod, Crankshaft & Flywheel	56
Service Brake Assembly	7	Oil Pump, Breather & Filter	57
Brake System Master Cylinder No. 69–2640	8	Flywheel Housing & Oil Pan Assembly	58
Traction Pedal & Cruise Control Assembly	9	Intake & Exhaust Manifold Assembly	59
Tool Box Assembly	10	Turbocharger Assembly No. 70–6430	60
Control Box Assembly	11	Turbocharger Oil Pipe Assembly	61
Diagnostic Display Assembly	12	Fuel System Assembly	62–63
Upper Control Panel Assembly	13	Fuel Injection Pump Assembly	64–65
Lower Control Panel Assembly	14	Governor Assembly	66–67
Electrical Schematic	15	Fuel Feed Pump Assembly No. 70–5700	68
Controller Electrical Schematic	16	Air Cleaner Assembly No. 69–1890	69
Operators Control Panel Electrical Schematic	17	Fuel Filter Assembly	70
Throttle Assembly	18	Solenoid Valve Assembly No. 85–6230	71
Lift Valve Installation Assembly	19	Battery Frame Assembly	72
Lift Valve Assembly No. 69–1780	20	PTO Manifold Assembly	73–74
Counterbalance Manifold Assembly	21	Rear Axle Assembly	75–76
Fuel Tank Assembly	22	Hydraulic Cylinder Assembly No. 69–1960	77
Hydraulic Tank Assembly	23	Front Lift Arm Assembly	78
Hydraulic Filter Assembly	24	Hydraulic Cylinder Assembly No. 92–4971	79
Hydraulic Pump Installation Assembly	25	Center Deck Model No. 30592	
Double Gear Pump No. 69–2050	26	Carrier Frame Assembly	80
Frame Assembly	27–28	Center Deck Model No. 30592	81–82
Hydraulic System Diagnostic Panel Assembly	29	Center Deck Model No. 30592	
Hydraulic Line Clamps Assembly	30	Left Wing Assembly	83
Hydraulic Schematic	31	Center Deck Model No. 30592	
Front Wheel Assembly	32–33	Ring Wing Assembly	84
Wheel Motor No. 69–3050	34	Wing Deck Lift Assembly	85–86
Planetary Gear Drive Assembly No. 69–1730	35	Hydraulic Cylinder Assembly No. 74–2170	87
Wheel Brake Assembly	36	Wing Deck Latch Assembly	88
Variable Displacement Pump Installation	37–38	Wing Deck Lift Arm Assembly	89
Gear Pump & Flow Divider No. 69–2220	39	Wing Deck Model No. 30591 L.H. & 30593 R.H.	90
Variable Displacement Pump No. 93–9322	40–41	Wing Deck Model No. 30591 L.H. & 30593 R.H.	
Cowl Assembly	42	Drive Assembly	91
Hood Assembly	43	Hydraulic Motor Assembly No. 93–4363	92
Radiator & Oil Cooler Assembly	44–45	Spindle Assembly	93
Engine Installation Assembly	46–47	10" & 13" Segmented Tire Assemblies (Optional)	94
Starter & Alternator Installation Assembly	48	TORO Part Number Index	95–111
Starter Motor Assembly No. 70–5860	49		
Alternator Assembly No. 70–5760	50		