



Count on it.

Parts Catalog

**TITAN ZX5420 Zero-Turn-Radius
Riding Mower**

Model No. 74842—Serial No. 312000001 and Up

Ordering Replacement Parts

To order replacement parts, please supply the part number, the quantity, and the description of each part desired.

Understanding Reference Numbers

Each identified part in an illustration has a reference number. The reference number for a part also appears in the parts list, along with other information about the part.

This catalog uses two special reference number formats, one to indicate parts in a service assembly and another to indicate the quantity of a given part in an illustration.

Service Assembly Reference Numbers

Parts in service assemblies have reference numbers in the form a:b. The a represents the reference number of the entire service assembly and the b represents a sequential number unique to each part within the service assembly.

For example, a wheel assembly might be identified by reference number 6, the tire by 6:1, the valve by 6:2, and the wheel by 6:3. When you order the assembly identified by reference number 6, you receive all parts identified by reference numbers 6:1, 6:2, and 6:3. However, you may also order any part individually. Reference numbers of this type appear in illustration and in parts lists.

Reference Numbers Indicating Quantity

In an illustration, if a reference number indicates more than one part, the reference number has the form nX y. The n represents the quantity of the part, the X is the multiplication symbol, and the y represents the reference number.

For example, in an illustration, the reference number 2X 37 means that two of the parts identified by reference number 37 are indicated.

List of Abbreviations

AR: as required

ASM: assembly

BBC: blade brake control

BHTF: button head thread forming

CARR: carriage

CCW: counter clockwise

CW: clockwise

DEG: degrees

DPA: Dual Point Adjustment

ECM: electronic control module

EXT: external

FH: flat head

GA: gauge

HD: heavy-duty

HF: hex flange

HH: hex head

HHF: hex head flange

HHFTF: hex head flange thread forming

HJ: hex jam

HLH: hex lag head

HOC: height-of-cut

HSBH: hex socket button head

HSFH: hex socket flat head

HSH: hex socket head

HWH: hex washer head

HWTF: hex washer head thread forming

HYD: hydraulic

LH: left hand

LPG: Liquid Propane Gas

NI: nylon insert

NPTF: national pipe thread fine

PFH: phillips flat head

PPH: phillips pan head

PPHTF: phillips pan head thread forming

PRH: phillips round head

PTH: phillips truss head

PTO: power-take-off

RH: right hand

ROPS: roll-over protection system

RRB: rear roller brush

SFH: slotted fillister head

SHH: slotted hex head

SHWH: slotted hex washer head

SPH: slotted pan head

SQH: square head

SRH: slotted round head

STD: standard

TAP: self tapping

TTH: torx truss head

Contents

Main Frame and Caster Wheel Assembly	4
Wheel and Tire Assembly No. 115-2554	5
Control Panel and Body Styling Pod Assembly	6
Deck Lift Assembly	7
Seat Assembly	8
Traction Drive Assembly	9
RH Hydro Assembly No. 115-2550	10
LH Hydro Assembly No. 115-2551	12
Motion Control Assembly	14
Brake Link Assembly	16
Engine, Muffler and Clutch Assembly	17
Fuel Delivery Assembly	18
Multi Layer Fuel Tank Assembly No. 117-7352	19
Roll-Over Protection System Assembly	20
Electrical Assembly	21
54 Inch Deck Assembly	22
54 Inch Deck and Decal Assembly No. 117-5374	23
54 Inch Deck Belt and Hi-Flo Blade Assembly	24
Attachments and Accessories	25

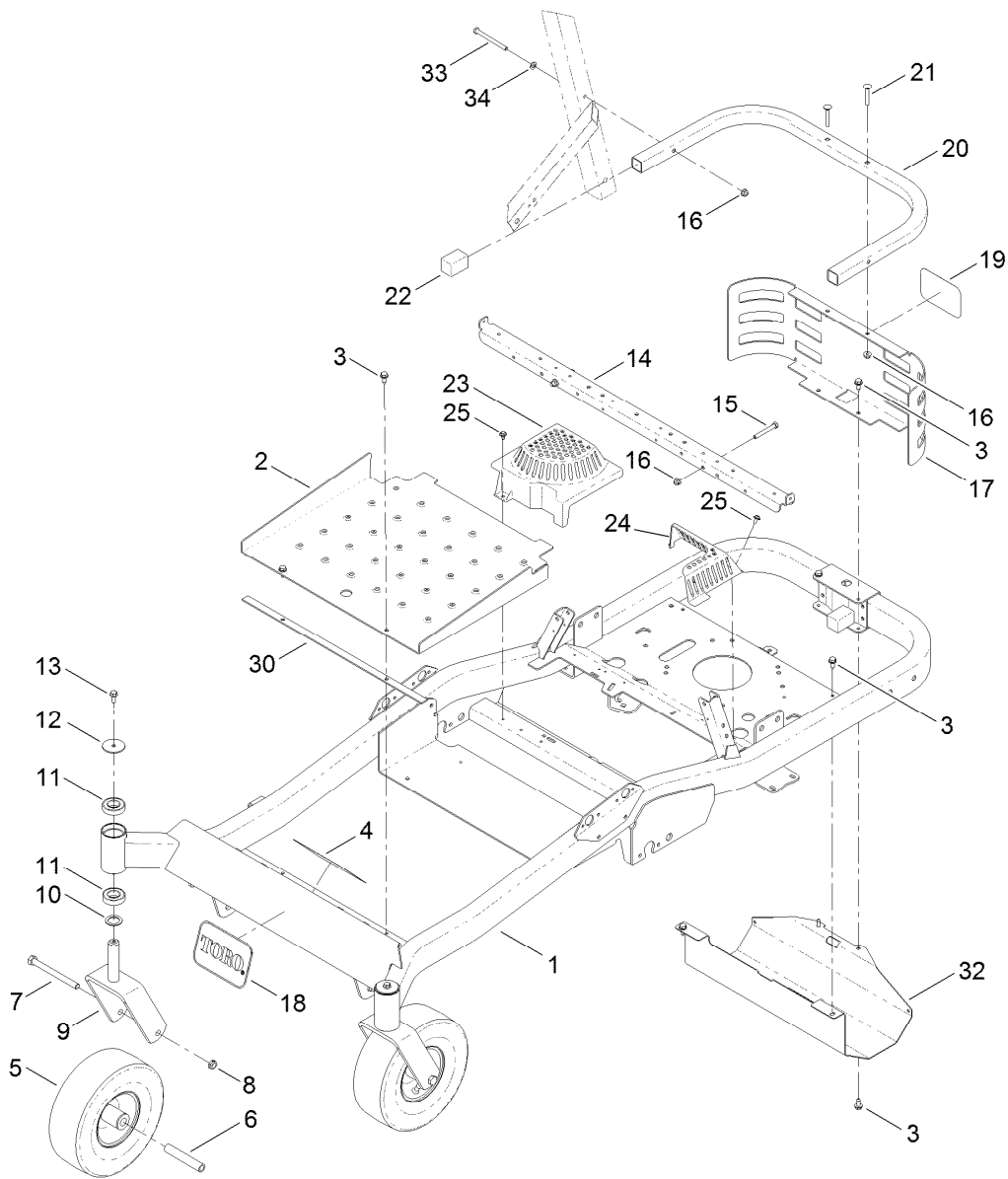

Main Frame and Caster Wheel Assembly

Ref.	Part Number	Qty.	Description	Ref.	Part Number	Qty.	Description
1	117-7356-01	1	Frame ASM	16	104-8300	6	Nut-Flange, NI
2	115-2531-05	1	Pan-Floor	17	120-2248-03	1	Guard-Rear
3	32144-70	8	Screw-HWHTF	18	62-5550	1	Decal
4	120-5466	1	Decal-Safety	19	105-8278	1	Decal
5	115-2554	2	Wheel And Tire ASM	20	121-0704-01	1	Tube-Guard
6	104-3667	2	Spanner-Wheel	21	3230-6	2	Screw-CARR
7	325-22	2	Screw-HH	22	121-2980	2	Cap
8	3296-45	2	Nut-Lock, NI	23	117-1241	1	Cover-Fan, RH
9	110-6634-01	2	Caster Fork ASM	24	117-1242	1	Cover-Fan, LH
10	10-8110	2	Washer-Thrust	25	46-8560	2	Screw-HHFTF
11	109-3678	4	Bearing-Ball	30	117-7238	1	Strip-Vibration, Anti
12	109-3724	2	Washer	32	120-2247-03	1	Guard-Muffer
13	3234-47	2	Screw-HHF	33	322-23	2	Screw-HH
14	119-8997-03	1	Support-Seat	34	3256-23	2	Washer-Flat
15	322-12	2	Screw-HH				

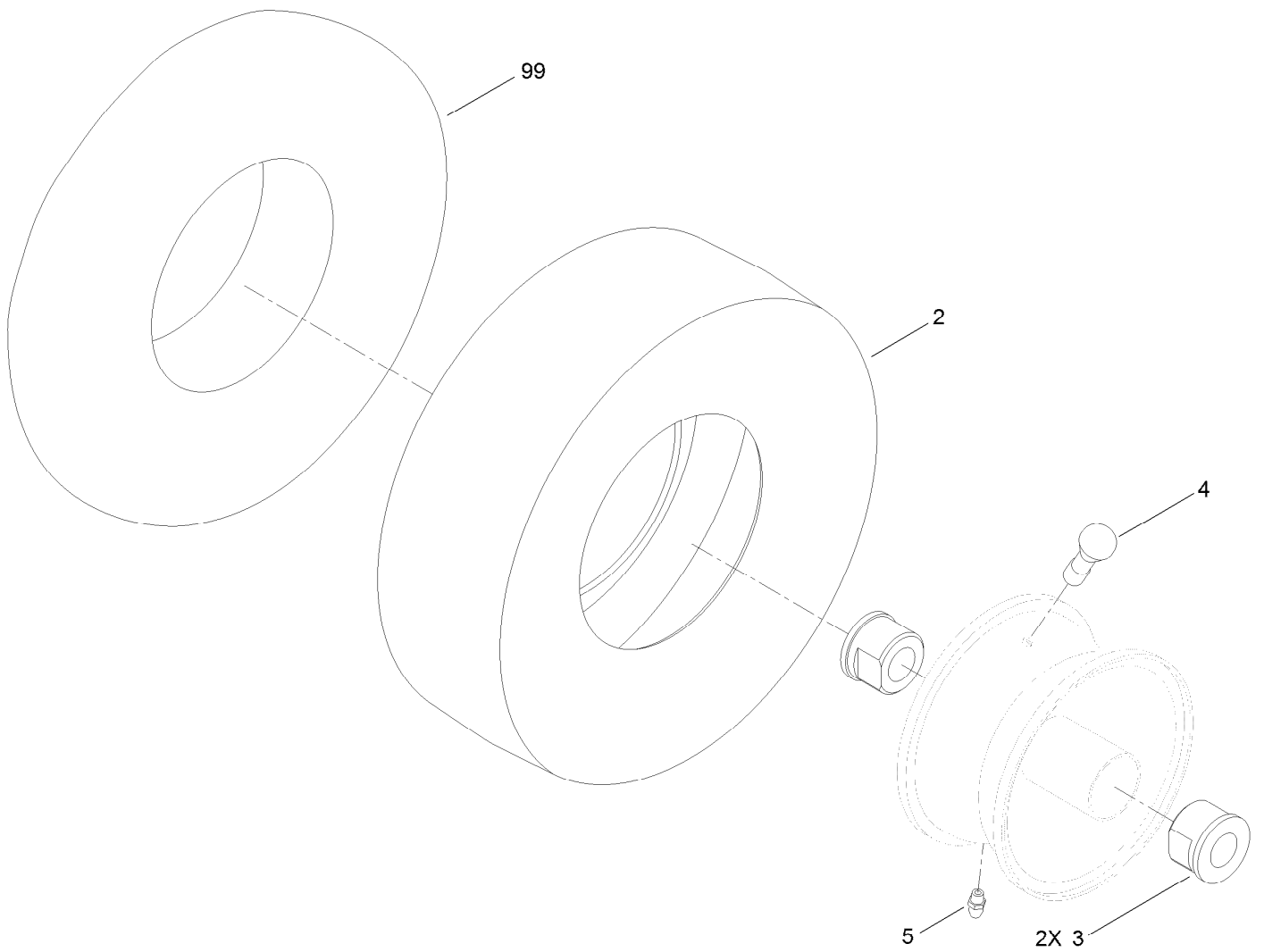

Wheel and Tire Assembly No. 115-2554

<i>Ref.</i>	<i>Part Number</i>	<i>Qty.</i>	<i>Description</i>
2	115-2557	1	Tire-Smooth
3	114-1640	2	Bushing-Flange
4	232-27	1	Stem-Valve
5	302-5	1	Fitting-Grease
99	117-1234	1	Tube-Inner

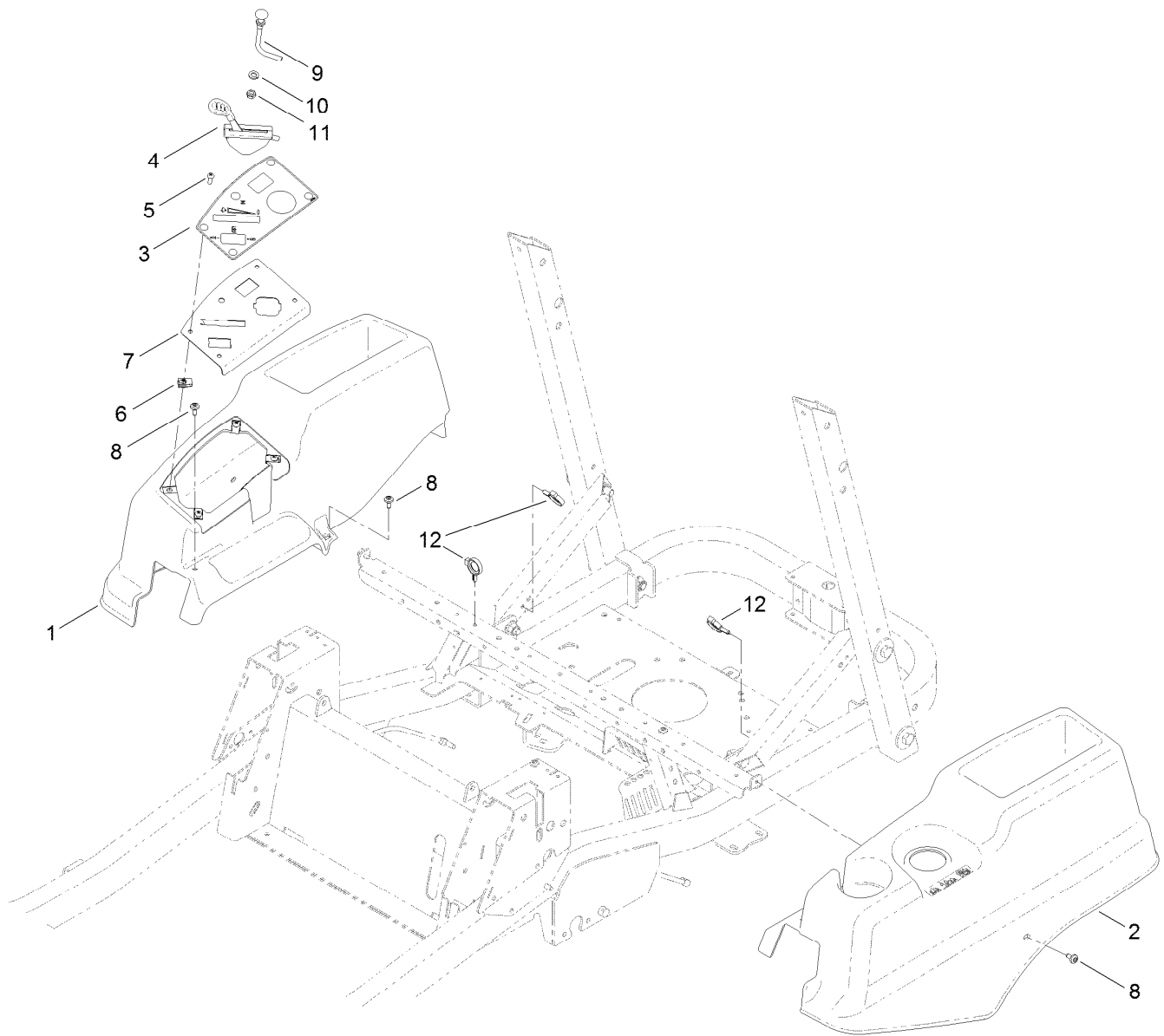

Control Panel and Body Styling Pod Assembly

<i>Ref.</i>	<i>Part Number</i>	<i>Qty.</i>	<i>Description</i>
1	115-2581	1	Pod-RH
2	115-2582	1	Pod-LH
3	115-9632	1	Decal-Panel, Control
4	121-0770	1	Cable-Throttle
5	3258-166	4	Screw-PRH
6	107069	4	Clip
7	115-2591-03	1	Panel-Control
8	112-4004	6	Screw-Shoulder
9	120-2291	1	Cable-Choke
10	3253-21	1	Washer-Lock
11	3220-3	1	Nut-HJ
12	105-1853	2	Clamp-Hose

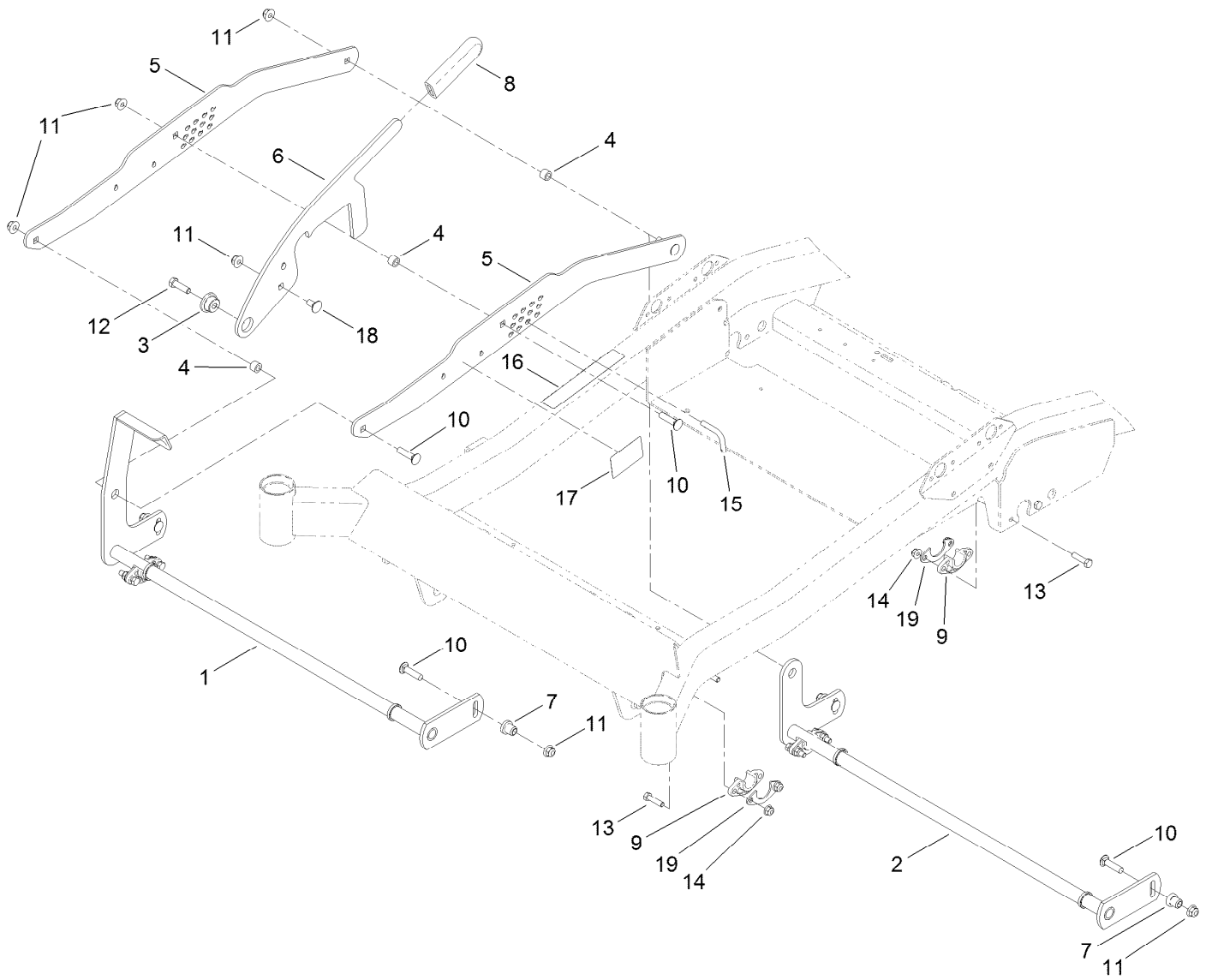

Deck Lift Assembly

<i>Ref.</i>	<i>Part Number</i>	<i>Qty.</i>	<i>Description</i>	<i>Ref.</i>	<i>Part Number</i>	<i>Qty.</i>	<i>Description</i>
1	115-2495-03	1	Pivot-Front	11	104-8301	8	Nut-Flange, NI
2	115-2498-03	1	Pivot-Rear	12	323-7	1	Screw-HH
3	117-1281	1	Bushing-Mount, HOC	13	322-6	8	Screw-HH
4	115-4986	3	Spacer	14	104-8300	8	Nut-Flange, NI
5	115-2503-03	2	Plate-Lift, Foot	15	117-1280	1	Pin-Keyed
6	115-2504	1	Plate-Stop, HOC	16	115-9644	1	Decal-HOC
7	65-5950	4	Bushing-Pulley	17	117-5344	1	Decal-Lock, Deck
8	1-633268	1	Grip-Lever	18	3231-1	1	Screw-CARR
9	115-5065	4	Bushing-Flange	19	116-2887	4	Gusset-Deck Lift
10	3231-4	7	Screw-CARR				

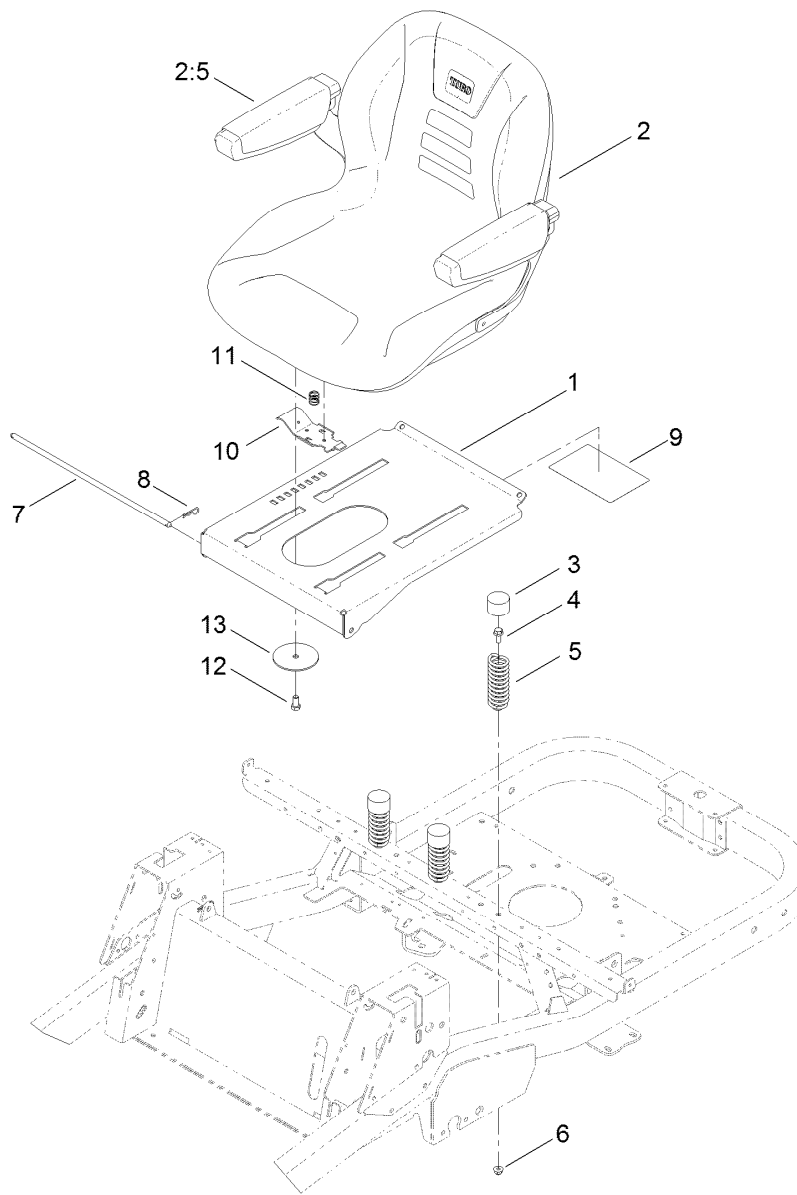

Seat Assembly

Ref.	Part Number	Qty.	Description
1	117-5320-03	1	Pan-Seat
2	115-5053	1	18 Inch Seat ASM
2:5	119-3307	1	Armrest Kit
3	701178	3	Cap-Protector
4	3234-47	3	Screw-HHF
5	92-7054	3	Spring-Compression
6	104-8300	3	Nut-Flange, NI
7	115-4966	1	Rod-Stop
8	3290-250	2	Pin-Hair
9	115-9630	1	Decal-Maintenance
10	115-9623	1	Latch-Seat
11	115-9624	1	Spring-Compression
12	323-4	1	Screw-HH
13	117-5307	1	Washer-Seat

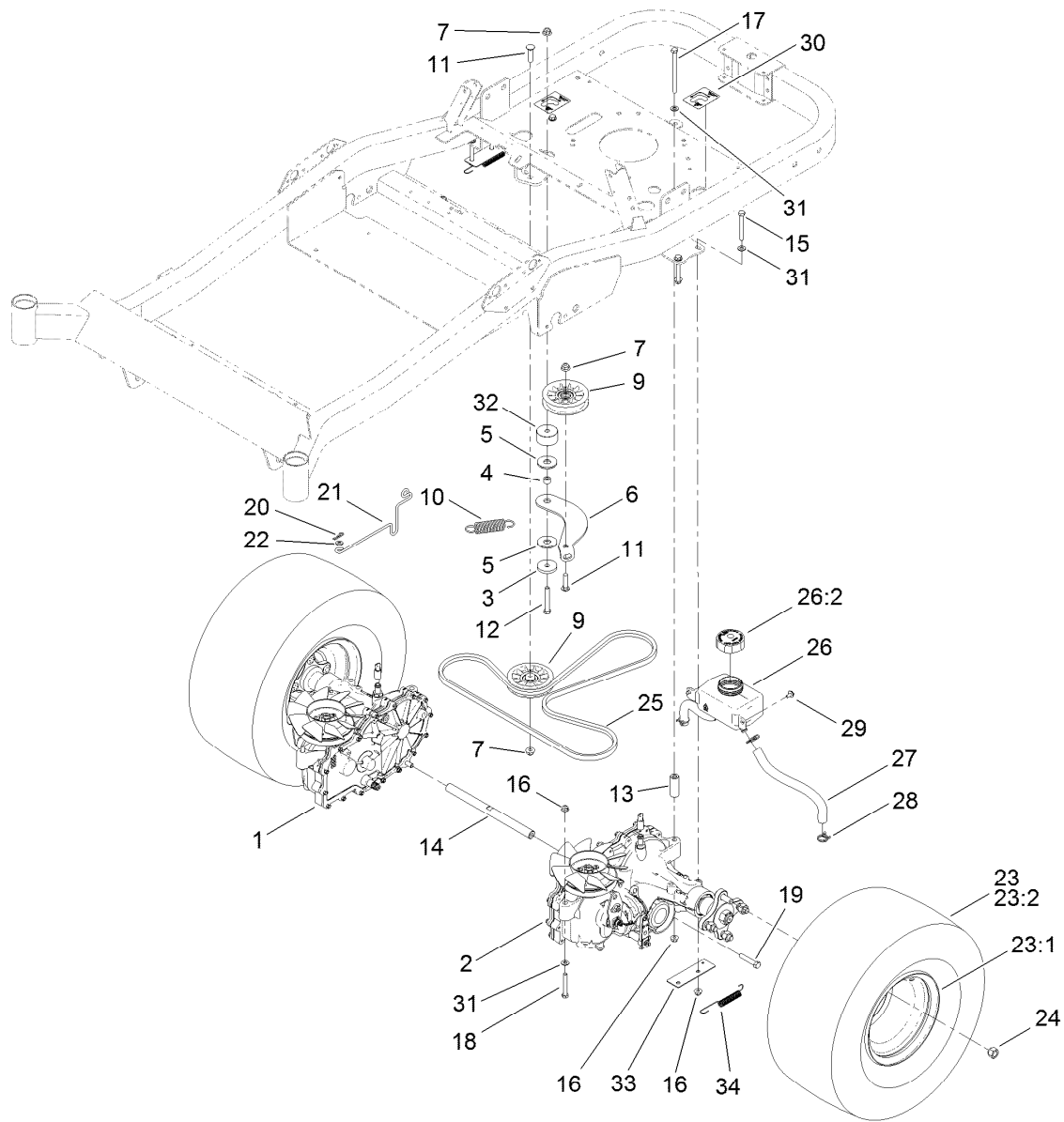

Traction Drive Assembly

Ref.	Part Number	Qty.	Description	Ref.	Part Number	Qty.	Description
1	115-2550	1	RH Hydro Transmission ASM	19	323-10	2	Screw-HH
2	115-2551	1	LH Hydro Transmission ASM	20	1-806003	2	Pin-Cotter, Hair
3	110-9981	1	Washer-Plain	21	115-4990	2	Rod-Bypass
4	115-4986	1	Spacer	22	3256-22	2	Washer-Flat
5	114-0463	2	Washer-Friction, Composite	23	109-5268	2	Wheel And Tire ASM
6	117-5350	1	Arm-Idler	23:1	109-5270	1	Wheel
7	104-8301	3	Nut-Flange, NI	23:2	109-5269	1	Tire
9	109-3397	2	Pulley-Idler, Flat	24	242-50	8	Nut-Lug
10	1-603402	1	Spring-Extension	25	115-9613	1	V-Belt
11	3231-4	2	Screw-CARR	26	115-9618	1	HYD Reservoir ASM
12	323-12	1	Screw-HH	26:2	109-3320	1	Cap-Reservoir, HYD
13	109-3652	2	Spacer-Hydro	27	115-4969	2	Hose-Overflow
14	115-2559	1	Shaft-Cross, Hydro	28	117-1193	4	Clamp-Hose
15	322-13	4	Screw-HH	29	46-8560	2	Screw-HHFTF
16	104-8300	8	Nut-Flange, NI	30	117-1158	2	Decal-Bypass
17	322-38	2	Screw-HH	31	3256-23	8	Washer-Flat
18	322-11	2	Screw-HH	32	117-5351	1	Spacer
				33	117-7248-03	2	Plate-Spring
				34	110769	2	Spring-Extension

RH Hydro Assembly No. 115-2550

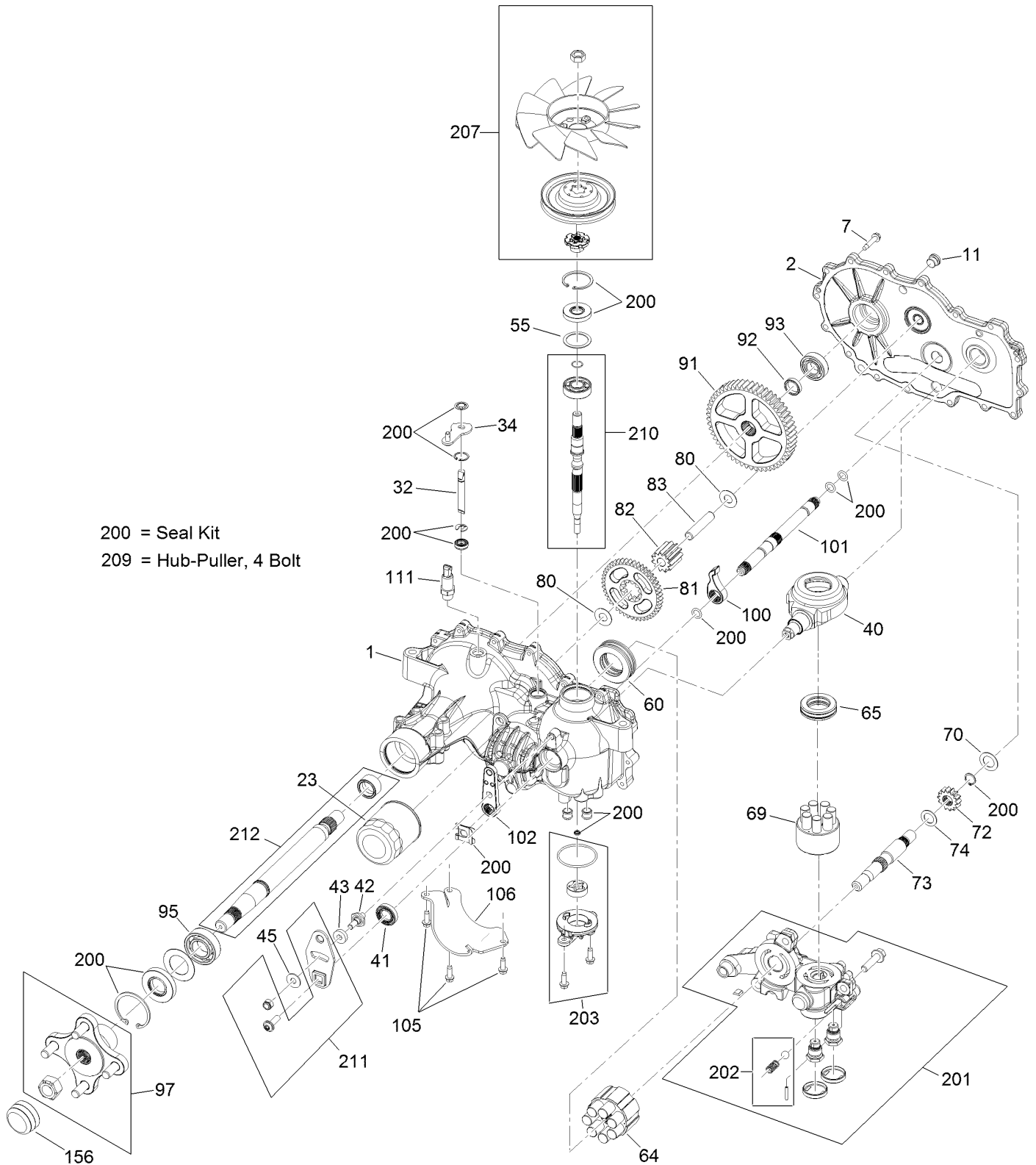

RH Hydro Assembly No. 115-2550 (continued)

<i>Ref.</i>	<i>Part Number</i>	<i>Qty.</i>	<i>Description</i>	<i>Ref.</i>	<i>Part Number</i>	<i>Qty.</i>	<i>Description</i>
1	117-5357	1	RH Main Housing Kit	82	114-1693	1	Gear-11T
2	117-5358	1	Housing Side Kit	83	104-5329	1	Pin-Jackshaft
7	117-5359	16	Screw-HHF	91	114-1694	1	Gear-54T
11	104-2189	1	Plug-Thread, Straight	92	120-7975	1	Spacer
23	109-3321	1	Element-Oil Filter, HYD	93	114-1696	1	Bearing-Ball
32	114-1685	1	Rod-Bypass	95	120-7976	1	Bearing-Ball
34	107-2490	1	Arm-Bypass	97	109-5939	1	Hub Kit
40	104-5304	1	Swashplate-Trunnion	100	114-1697	1	Pawl-Brake
41	104-5313	1	Seal-Lip	101	120-7977	1	Brake Shaft Kit
42	104-2116	1	Stud	102	125-0021	1	Handle, Brake
43	112-9853	1	Puck-Friction	105	104-2120	3	Screw
45	114-8491	1	Washer	106	120-7981	1	Guard-Filter, RH
55	104-5308	1	Spacer	111	109-3278	1	Adapter-Straight
60	112-4154	1	Bearing-Thrust	156	115-5057	1	Cover-Nut, Axle
64	114-1689	1	Motor Cylinder Block Kit	200	109-3537	1	Complete Seal Kit
65	94-6922	1	Bearing-Thrust	201	114-8463	1	RH Center Section Kit
69	110-8561	1	Pump Block ASM	202	114-8464	1	Charge Relief Kit
70	104-5339	1	Washer-Flat	203	114-8465	1	Charge Kit
72	114-1690	1	Gear-14T	207	125-0059	1	Kit, Fan And Pulley
73	114-1691	1	Shaft-Motor	209	114-8467	1	Hub-Puller, 4 Bolt
74	104-5360	1	Washer	210	117-5361	1	Shaft Input Kit
80	94-1933	1	Washer	211	117-5362	1	Arm Control Kit
81	114-1692	1	Gear-45T	212	114-8470	1	Axle Shaft Kit

LH Hydro Assembly No. 115-2551

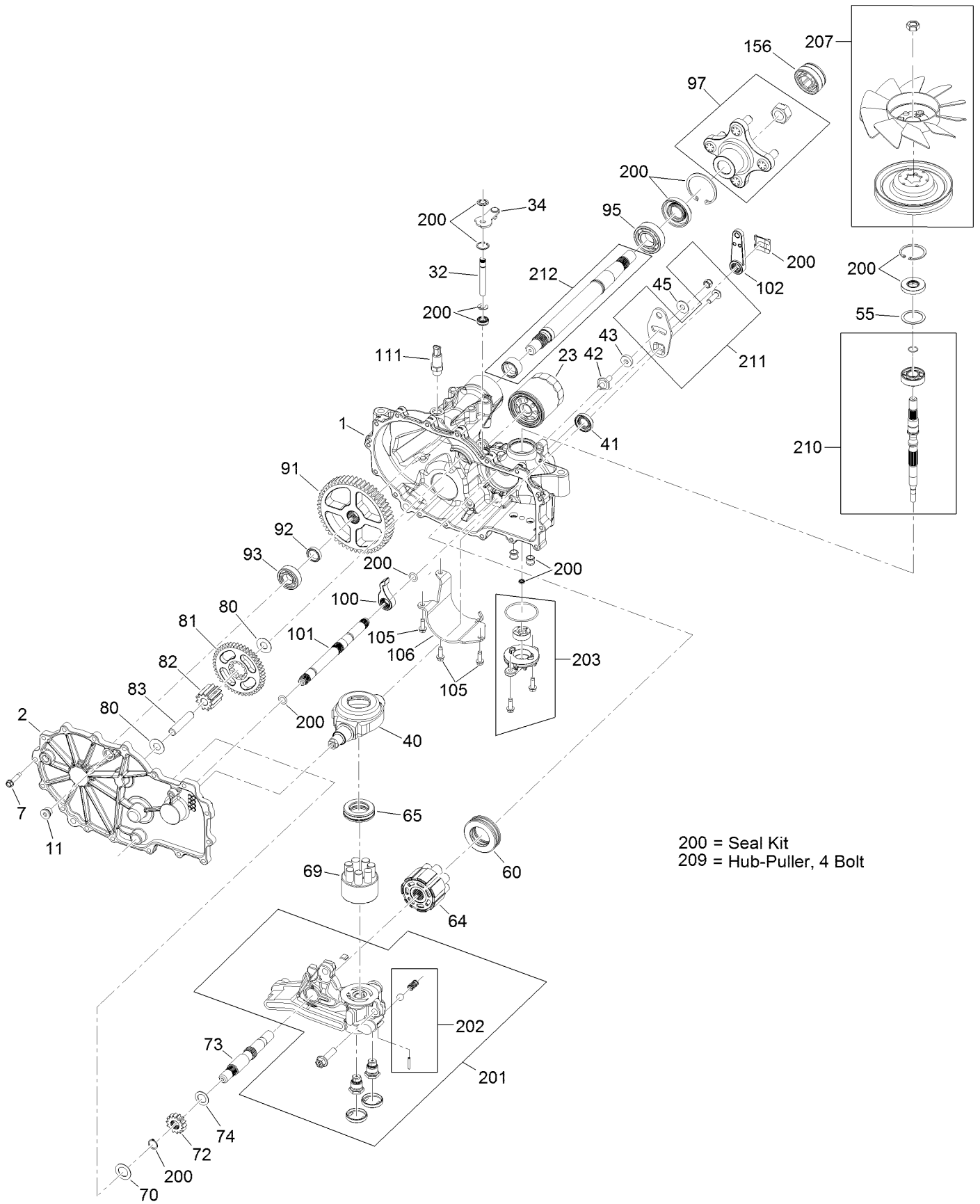

LH Hydro Assembly No. 115-2551 (continued)

<i>Ref.</i>	<i>Part Number</i>	<i>Qty.</i>	<i>Description</i>	<i>Ref.</i>	<i>Part Number</i>	<i>Qty.</i>	<i>Description</i>
1	114-8471	1	Main Housing Kit	82	114-1693	1	Gear-11T
2	114-8472	1	Side Cover Kit	83	104-5329	1	Pin-Jackshaft
7	117-5359	16	Screw-HHF	91	114-1694	1	Gear-54T
11	104-2189	1	Plug-Thread, Straight	92	120-7975	1	Spacer
23	109-3321	1	Element-Oil Filter, HYD	93	114-1696	1	Bearing-Ball
32	114-1685	1	Rod-Bypass	95	120-7976	1	Bearing-Ball
34	107-2490	1	Arm-Bypass	97	109-5939	1	Hub Kit
40	104-5304	1	Swashplate-Trunnion	100	114-1697	1	Pawl-Brake
41	104-5313	1	Seal-Lip	101	120-7977	1	Brake Shaft Kit
42	104-2116	1	Stud	102	125-0021	1	Handle, Brake
43	112-9853	1	Puck-Friction	105	104-2120	3	Screw
45	114-8491	1	Washer	106	120-7979	1	Guard-Filter, LH
55	104-5308	1	Spacer	111	109-3278	1	Adapter-Straight
60	114-1688	1	Bearing-Thrust	156	115-5057	1	Cover-Nut, Axle
64	114-1689	1	Motor Cylinder Block Kit	200	109-3537	1	Complete Seal Kit
65	94-6922	1	Bearing-Thrust	201	114-8476	1	LH Center Section Kit
69	110-8561	1	Pump Block ASM	202	114-8464	1	Charge Relief Kit
70	104-5339	1	Washer-Flat	203	114-8465	1	Charge Kit
72	114-1690	1	Gear-14T	207	125-0059	1	Kit, Fan And Pulley
73	114-1691	1	Shaft-Motor	209	114-8467	1	Hub-Puller, 4 Bolt
74	104-5360	1	Washer	210	117-5361	1	Shaft Input Kit
80	94-1933	2	Washer	211	117-5362	1	Arm Control Kit
81	114-1692	1	Gear-45T	212	114-8470	1	Axle Shaft Kit

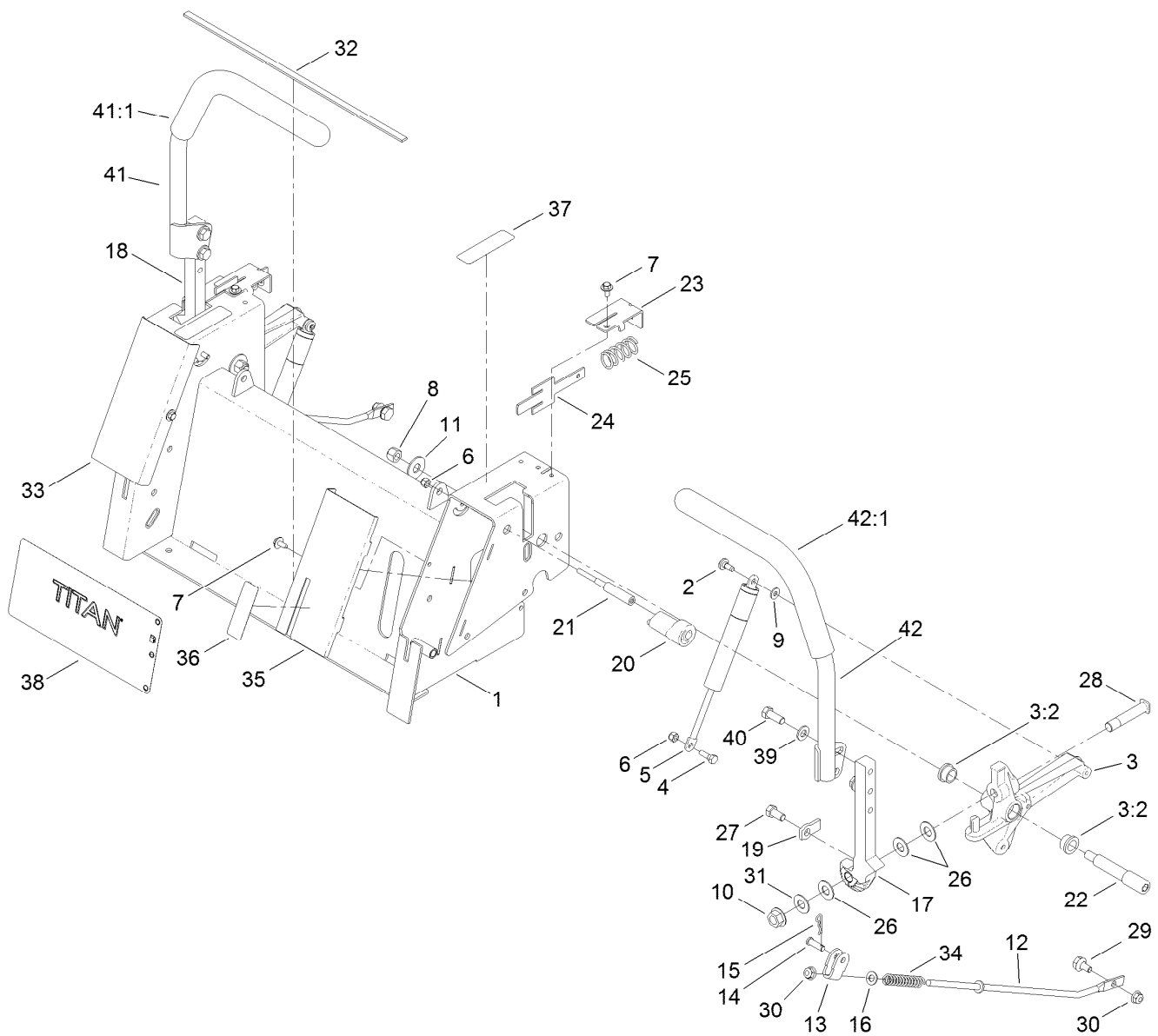

Motion Control Assembly

Ref.	Part Number	Qty.	Description	Ref.	Part Number	Qty.	Description
1	115-2546-03	1	Box-Control	21	110-6874	2	Screw-Eccentric
2	112-4004	2	Screw-Shoulder	22	110-6875	2	Bolt-Shoulder
3	110-6828	2	Activator Arm ASM	23	110-6751	2	Bracket-Return
3:2	105-3455	2	Bushing	24	110-6750	2	Plate-Return
4	106-2214	2	Bolt-Shoulder	25	110-6752	2	Spring-Compression
5	109-2339	2	Damper-Control, Motion	26	110-6894	6	Washer-Pivot
6	3296-42	4	Nut-Lock, NI	27	323-4	2	Screw-HH
7	46-8560	4	Screw-HHFTF	28	110-6784	2	Bolt-Shoulder
8	3296-48	2	Nut-Lock, NI	29	37-8771	2	Bolt-Shoulder
9	119-8952	2	Washer	30	104-8300	4	Nut-Flange, NI
10	32128-23	2	Nut-HF	31	112-9771	2	Washer-Teflon
11	3256-5	2	Washer-Flat	32	117-7237	1	Strip-Vibration, Anti
12	117-7422	2	Rod-Control	33	117-1255-03	1	Cover-Control, RH
13	117-7423	2	Bracket-Control	34	1-603807	2	Spring-Return, Neutral
14	1-808280	2	Pin-Clevis	35	115-2561-03	1	Cover-Control, LH
15	1-806003	2	Pin-Cotter, Hair	36	115-9625	1	Decal
16	3256-23	2	Washer-Flat	37	99-8936	2	Decal-Control, Motion
17	110-6783-05	1	Arm-Actuator, LH	38	119-8986	1	Decal
18	110-6782-05	1	Arm-Actuator, RH	39	3256-24	4	Washer-Flat
19	115-5023	2	Tab-Stop	40	323-6	4	Screw-HH
20	110-6873	2	Eccentric	41	121-0731	1	Handle-Control, RH

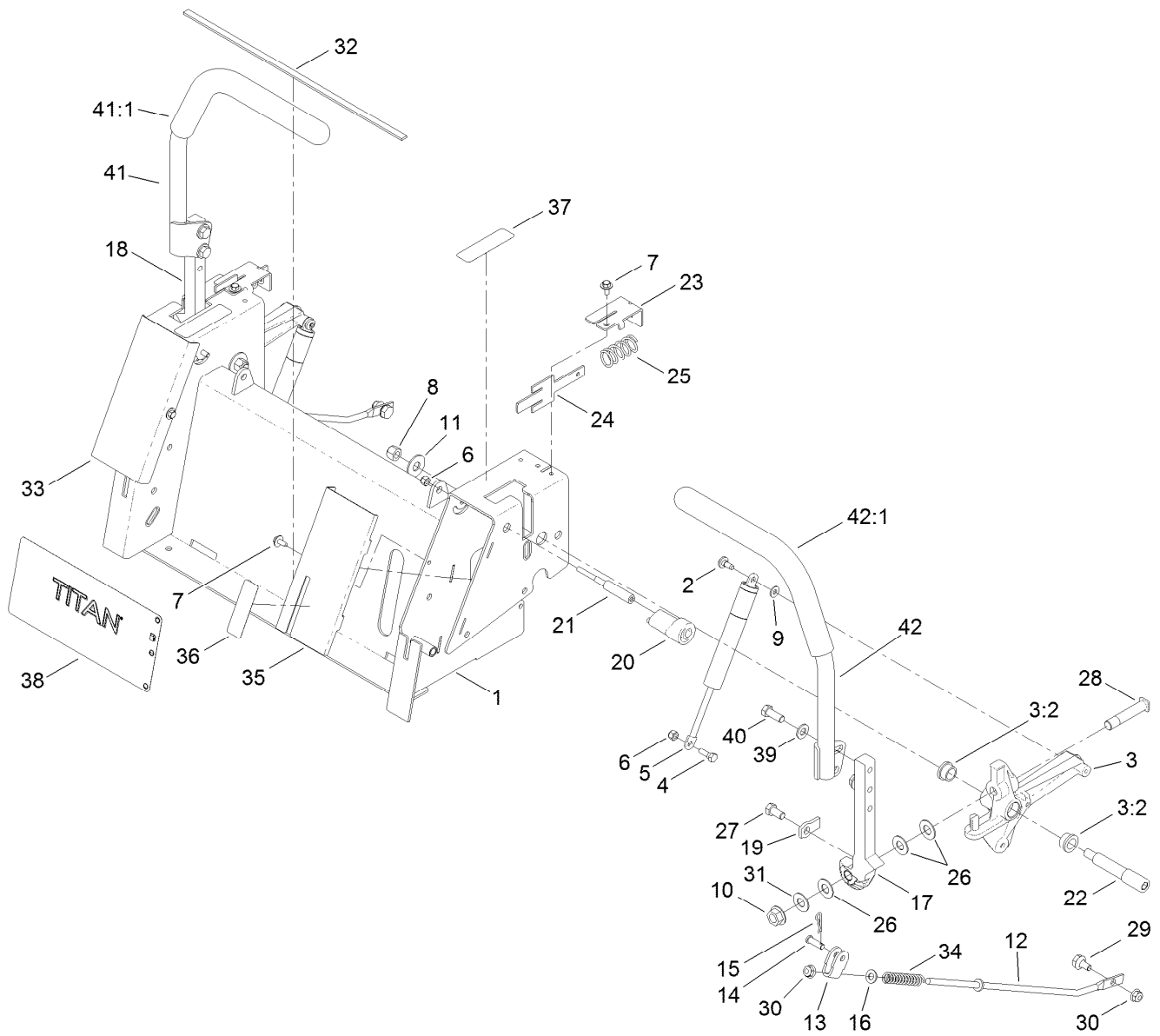

Motion Control Assembly (continued)

<i>Ref.</i>	<i>Part Number</i>	<i>Qty.</i>	<i>Description</i>
41:1	121-0726	1	Grip

<i>Ref.</i>	<i>Part Number</i>	<i>Qty.</i>	<i>Description</i>
42	121-0730	1	Handle-Control, LH
42:1	121-0726	1	Grip

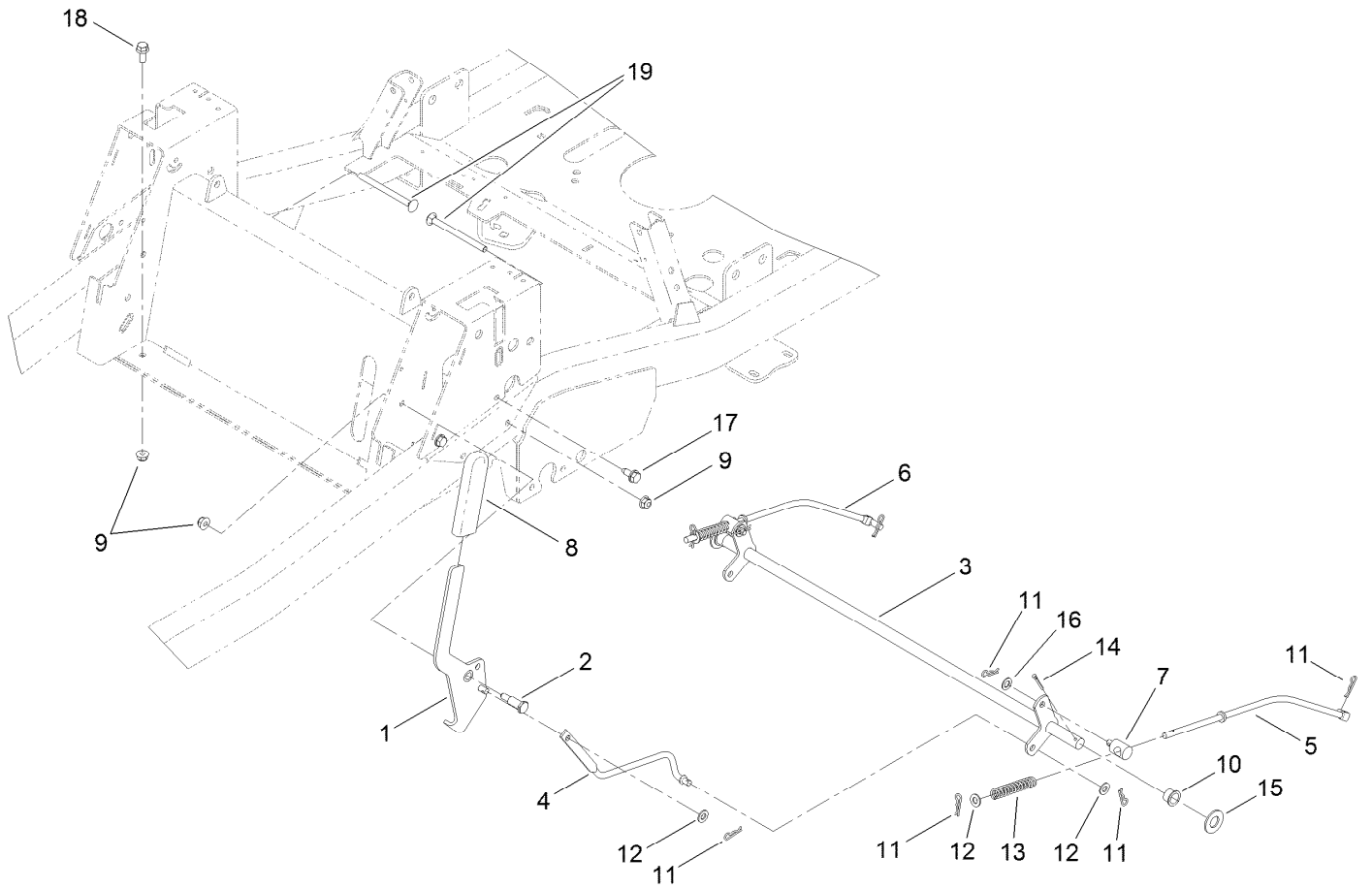

Brake Link Assembly

<i>Ref.</i>	<i>Part Number</i>	<i>Qty.</i>	<i>Description</i>	<i>Ref.</i>	<i>Part Number</i>	<i>Qty.</i>	<i>Description</i>
1	119-3460	1	Handle-Brake	11	1-806003	8	Pin-Cotter, Hair
2	63-2650	1	Screw-Shoulder	12	3256-23	4	Washer-Flat
3	115-5071-03	1	Brake-Bellcrank	13	1-603807	2	Spring-Return, Neutral
4	115-5074	1	Link-Brake	14	3272-11	2	Pin-Cotter
5	117-7322	1	Rod-Brake, LH	15	3256-27	2	Washer-Flat
6	117-7323	1	Rod-Brake, RH	16	40-1940	2	Washer
7	115-9681	2	Fitting-Rod	17	32144-70	4	Screw-HWHTF
8	1-633268	1	Grip-Lever	18	3234-47	2	Screw-HHF
9	104-8300	5	Nut-Flange, NI	19	106-9758	2	Screw-CARR
10	256-292	2	Bushing-Flange, NI				

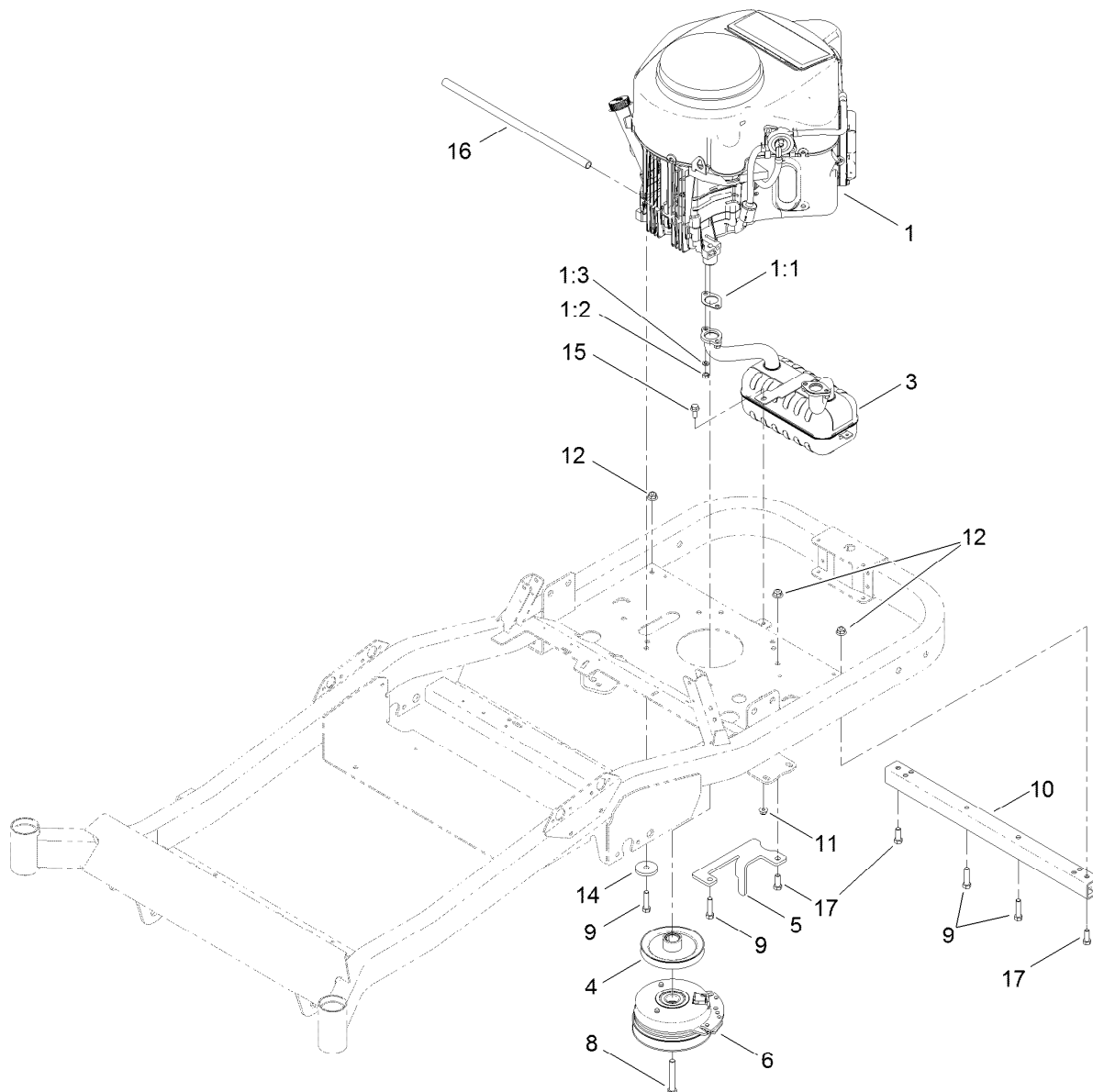

Engine, Muffler and Clutch Assembly

Ref.	Part Number	Qty.	Description
1		1	Engine-Kawasaki, Fr691V-S12-R●■
1:1	1-653313	2	Gasket-Exhaust
1:2	114-3549	4	Nut
1:3	114-3550	4	Washer-Lock, Spring
3	117-7465	1	Muffler-Kawasaki Twin
4	115-2568	1	Pulley-Engine
5	117-7344-03	1	Bracket-Stop, PTO
6	117-1252	1	Clutch-PTO

Ref.	Part Number	Qty.	Description
8	3212-11	1	Screw-HH
9	323-50	4	Bolt-HH
10	117-7335-03	1	Tube-Stiffener
11	104-8300	1	Nut-Flange, NI
12	104-8301	3	Nut-Flange, NI
14	110-9981	1	Washer-Plain
15	3234-47	1	Screw-HHF
16	106-7022	1	Tube-Drain, Oil
17	323-6	3	Screw-HH

● Not serviced separately

■ Obtain parts from www.kawpowerpc.com

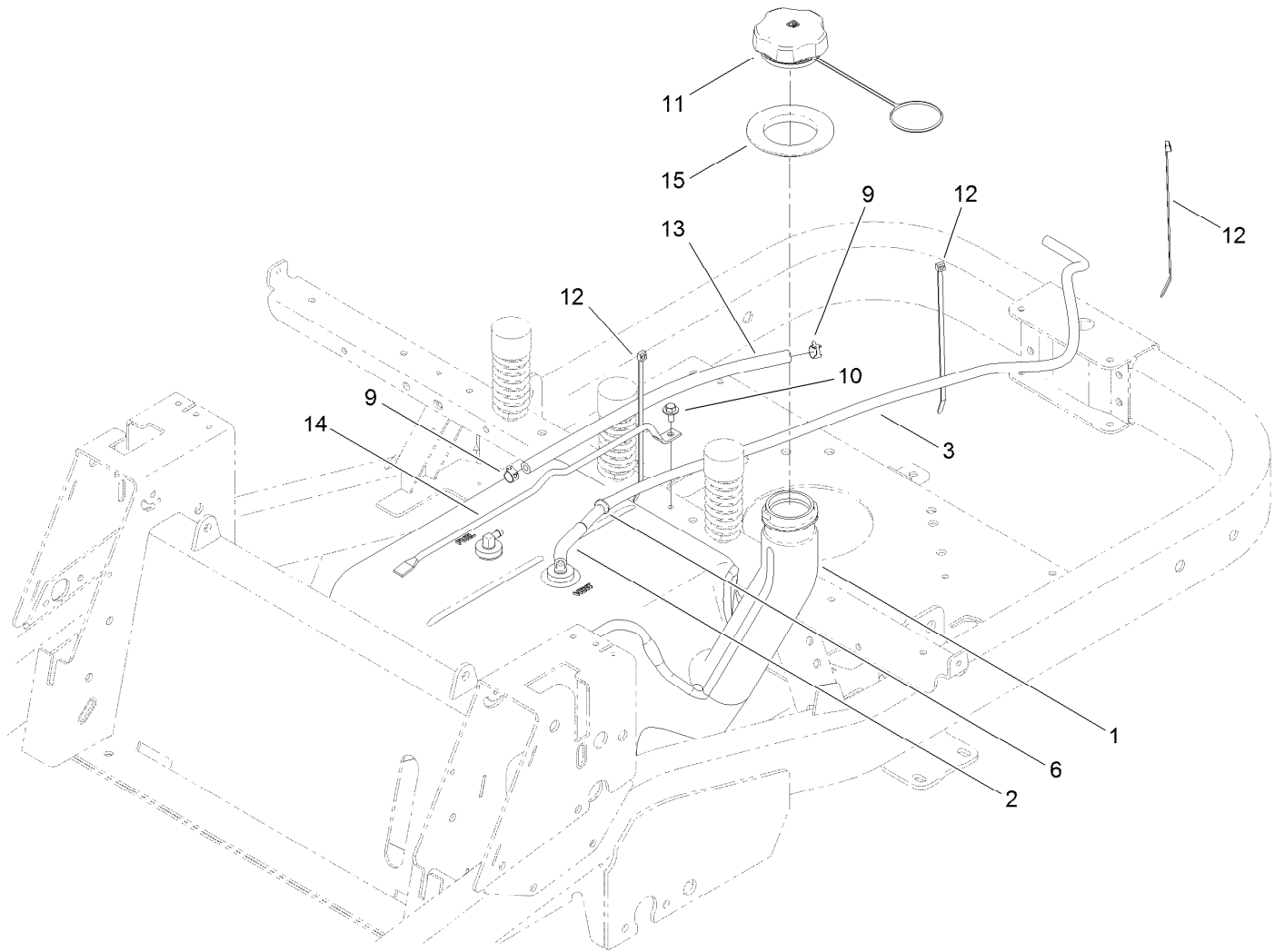

Fuel Delivery Assembly

<i>Ref.</i>	<i>Part Number</i>	<i>Qty.</i>	<i>Description</i>
1	117-7352	1	Multi Layer Fuel Tank ASM
2	114-3765	1	Hose-Fuel
3	51-3212	1	Hose-Fuel
6	121-0743	1	Adapter-Orifice
9	2412-98	2	Clamp-Hose
10	46-8560	1	Screw-HHFTF
11	114-0294	1	Cap-Fuel, Racheting
12	614249	3	Tie-Cable
13	107-0589	1	Hose-Fuel
14	115-2620	1	Rod-Tank, Gas
15	117-1298	1	Seal-Tank

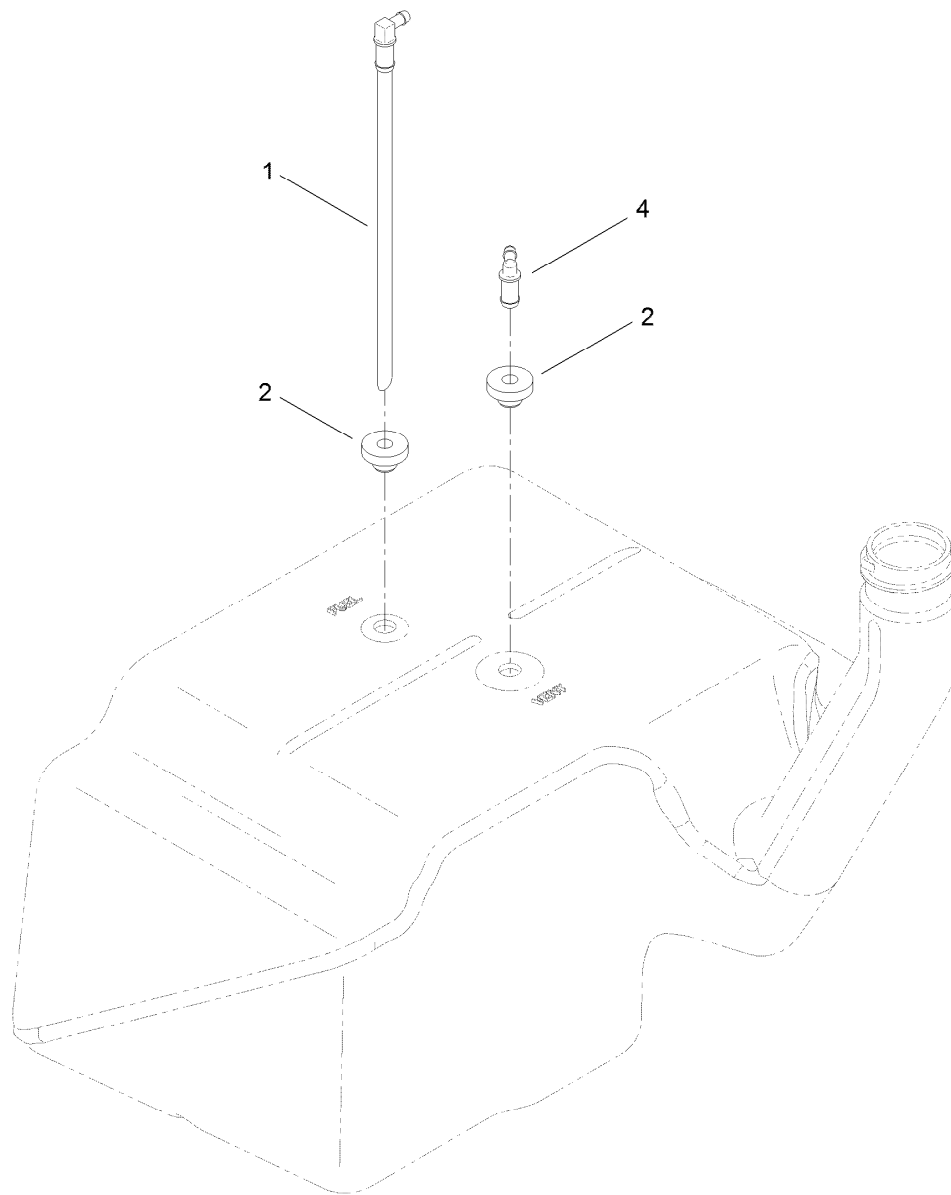

Multi Layer Fuel Tank Assembly No. 117-7352

<i>Ref.</i>	<i>Part Number</i>	<i>Qty.</i>	<i>Description</i>
1	121-0793	1	Connector-Elbow, 90 DEG
2	46-6560	2	Bushing
4	117-7400	1	Fitting-Plastic

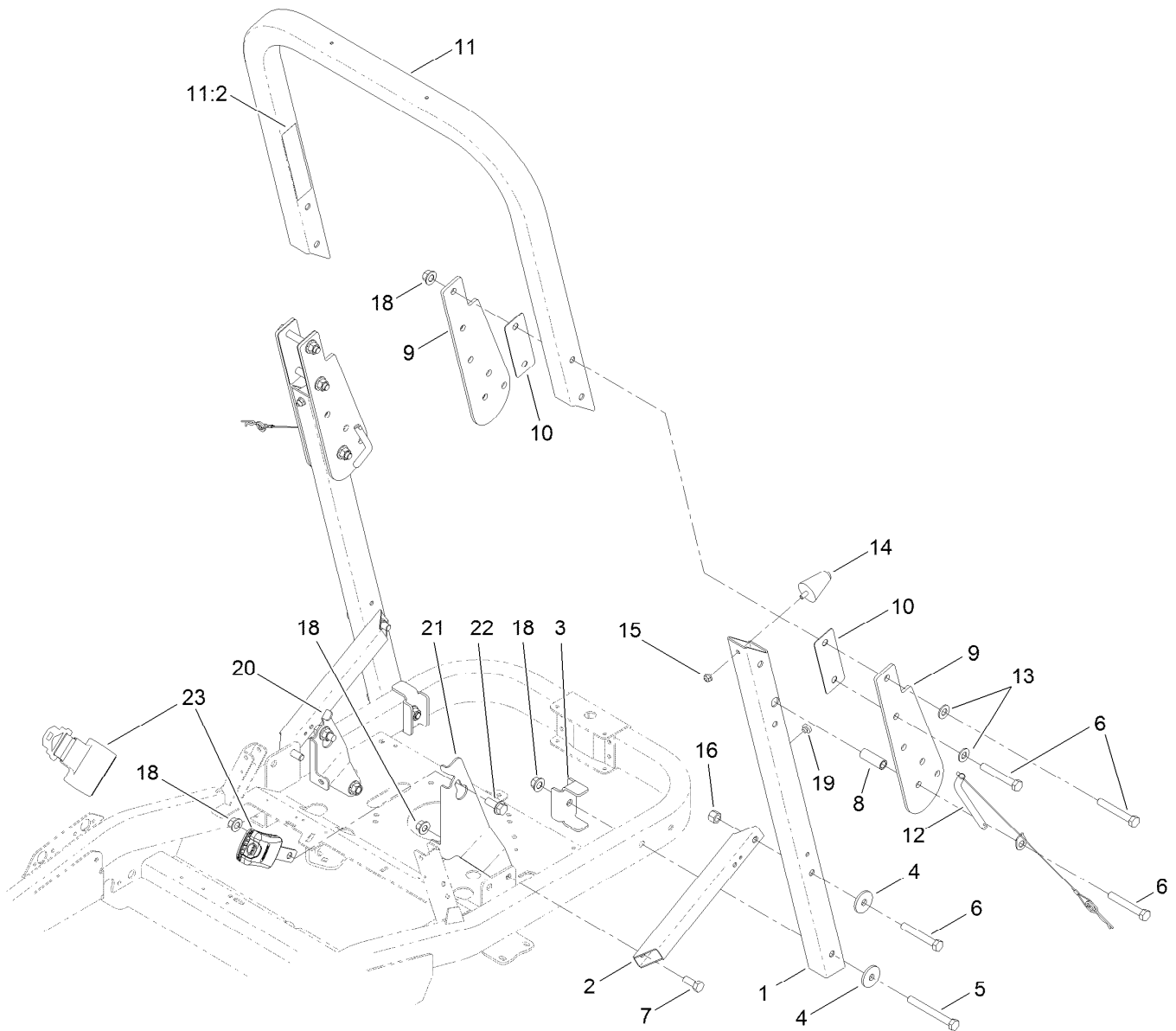

Roll-Over Protection System Assembly

Ref.	Part Number	Qty.	Description
1	121-2986-03	2	Tube-ROPS, Lower
2	115-4962-03	2	Tube-Support, ROPS
3	115-4963-03	2	Bracket-Reinforcing
4	84-1560	4	Washer-Thrust
5	325-18	2	Screw-HH
6	325-14	8	Screw-HH
7	325-5	2	Screw-HH
8	109-6653	2	Spacer
9	119-8911-03	4	Bracket-Pivot, ROPS
10	119-8926-03	4	Spacer-ROPS
11	119-8991	1	Upper ROPS ASM
11:2	107-3069	1	Decal-Warning, Folding ROPS

Ref.	Part Number	Qty.	Description
12	119-8970	2	Pin-ROPS
13	3256-26	4	Washer-Flat
14	114-1925	2	Bumper-Rubber
15	104-8300	2	Nut-Flange, NI
16	119-8969	2	Nut-Hex
18	99-5107	10	Nut-Lock
19	1-513658	2	Bumper
20	115-5038-03	1	Bracket-Seat Belt
21	115-5060-03	1	Bracket-Seat Belt
22	3234-38	2	Screw-HHF
23	109-9805	1	Seat Belt Kit

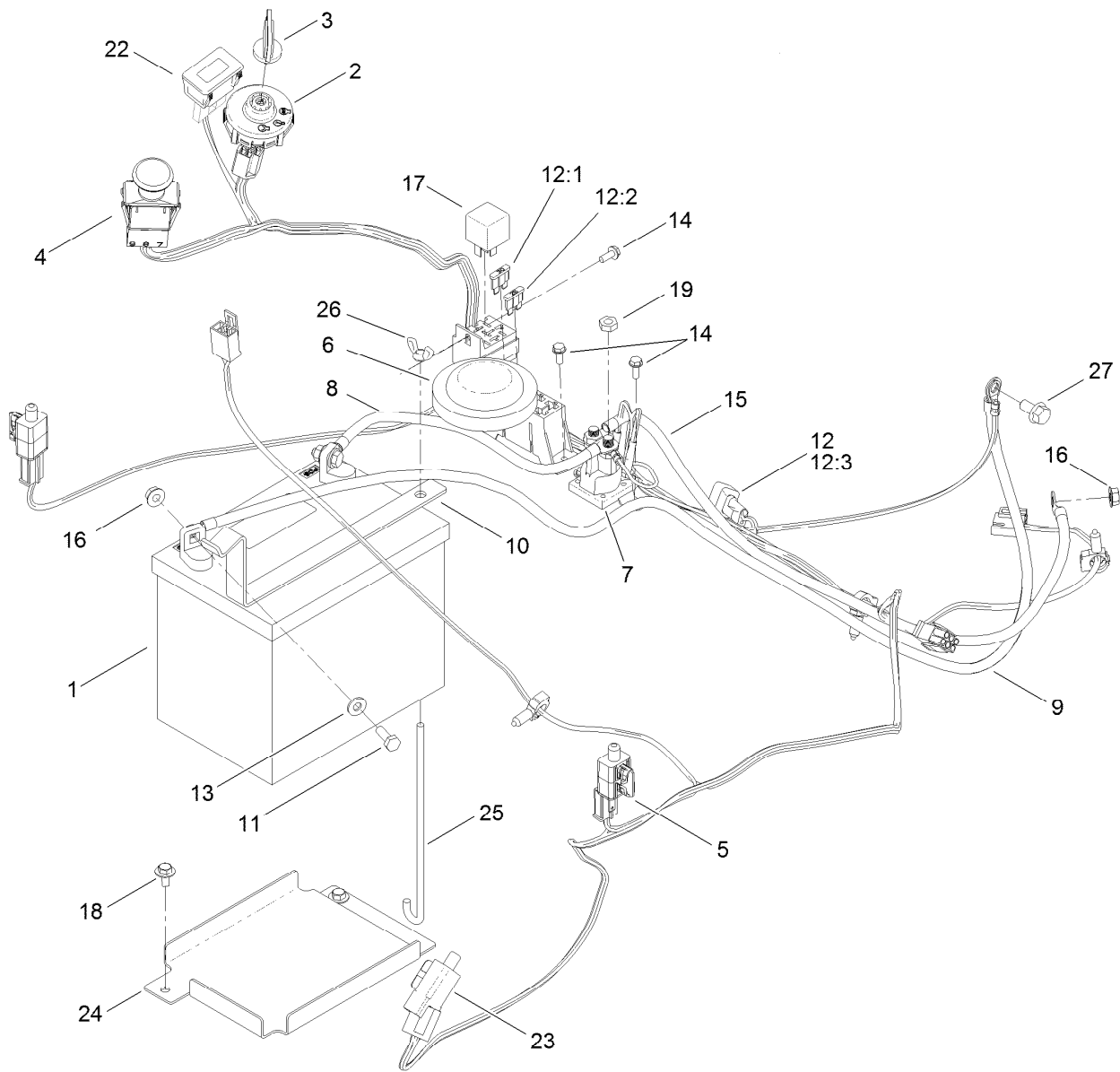

Electrical Assembly

<i>Ref.</i>	<i>Part Number</i>	<i>Qty.</i>	<i>Description</i>
1	105-1692	1	Battery
2	117-2221	1	Switch-Ignition
3	63-8360	1	Key-Ignition
4	103-5221	1	Switch-PTO
5	110-6765	2	Switch-Single Pole No
6	100-3524	1	Switch-Seat
7	117-1197	1	Solenoid
8	117-5342	1	Cable-Battery, Positive
9	117-7240	1	Cable-Battery, Negative
10	117-7313-01	1	Strap-Battery
11	321-4	2	Screw-HH
12	121-3015	1	Harness-Wire
12:1	109103	1	Fuse-Blade, 30 Amp
12:2	109102	1	Fuse-Blade, 25 Amp

<i>Ref.</i>	<i>Part Number</i>	<i>Qty.</i>	<i>Description</i>
12:3	100-4918	1	Diode
13	3256-22	2	Washer-Flat
14	32144-1	5	Screw-Taptite
15	92-6989	1	Wire-21 Inch
16	32128-33	3	Nut-HF
17	98-7249	1	Relay
18	46-8560	2	Screw-HHFTF
19	3220-2	2	Nut-Jam
22	120-2244	1	Hourmeter
23	99-7408	1	Switch-Reverse
24	117-1283-03	1	Tray-Battery
25	1-633651	1	Bolt-Holddown
26	1-543792	1	Wingnut
27	33104-016	1	Screw-HHF

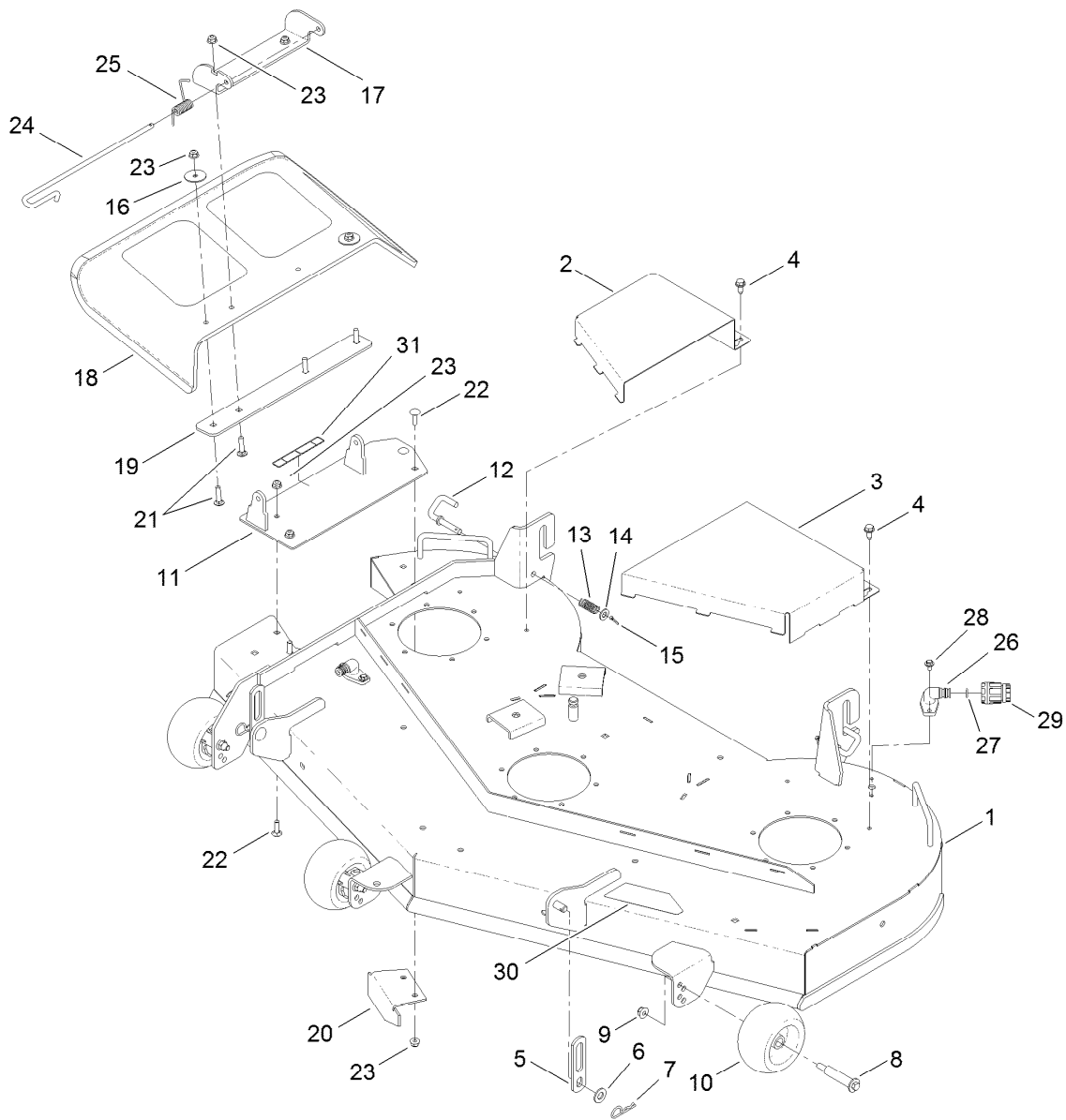

54 Inch Deck Assembly

Ref.	Part Number	Qty.	Description	Ref.	Part Number	Qty.	Description
1	117-5374	1	54 Inch Deck ASM	17	114-1648-03	1	Bracket-Deflector, Upper
2	117-7404-03	1	Cover-Belt, RH	18	117-1270	1	Deflector-Molded
3	117-7405-03	1	Cover-Belt, LH	19	115-5048-03	1	Plate-Deflector
4	32144-70	4	Screw-HWHTF	20	115-9653-03	1	Baffle-Cutoff
5	115-2622	2	Link-Lift	21	3230-3	4	Screw-CARR
6	3256-26	2	Washer-Flat	22	3230-22	4	Screw-CARR
7	1-806005	2	Pin-Hair	23	104-8300	8	Nut-Flange, NI
8	112-3977	3	Bolt-Shoulder	24	109-8854	1	Pin-Chute
9	104-8301	3	Nut-Flange, NI	25	121-2983	1	Spring-Torsion
10	1-603299	3	Roller-Scalp, Anti	26	95-2747	2	Fitting-Washout
11	117-1282-03	1	Plate-Cover	27	46-6290	2	O-Ring, Seal
12	115-2470	2	Pin-Latch	28	46-8560	4	Screw-HHFTF
13	101853	2	Spring-Compression	29	95-3270	1	Connector-Hose
14	3256-24	2	Washer-Flat	30	117-5302	1	Decal
15	3272-10	2	Pin-Cotter	31	93-7009	1	Decal-Danger, Deflector
16	3256-68	2	Washer-Flat				

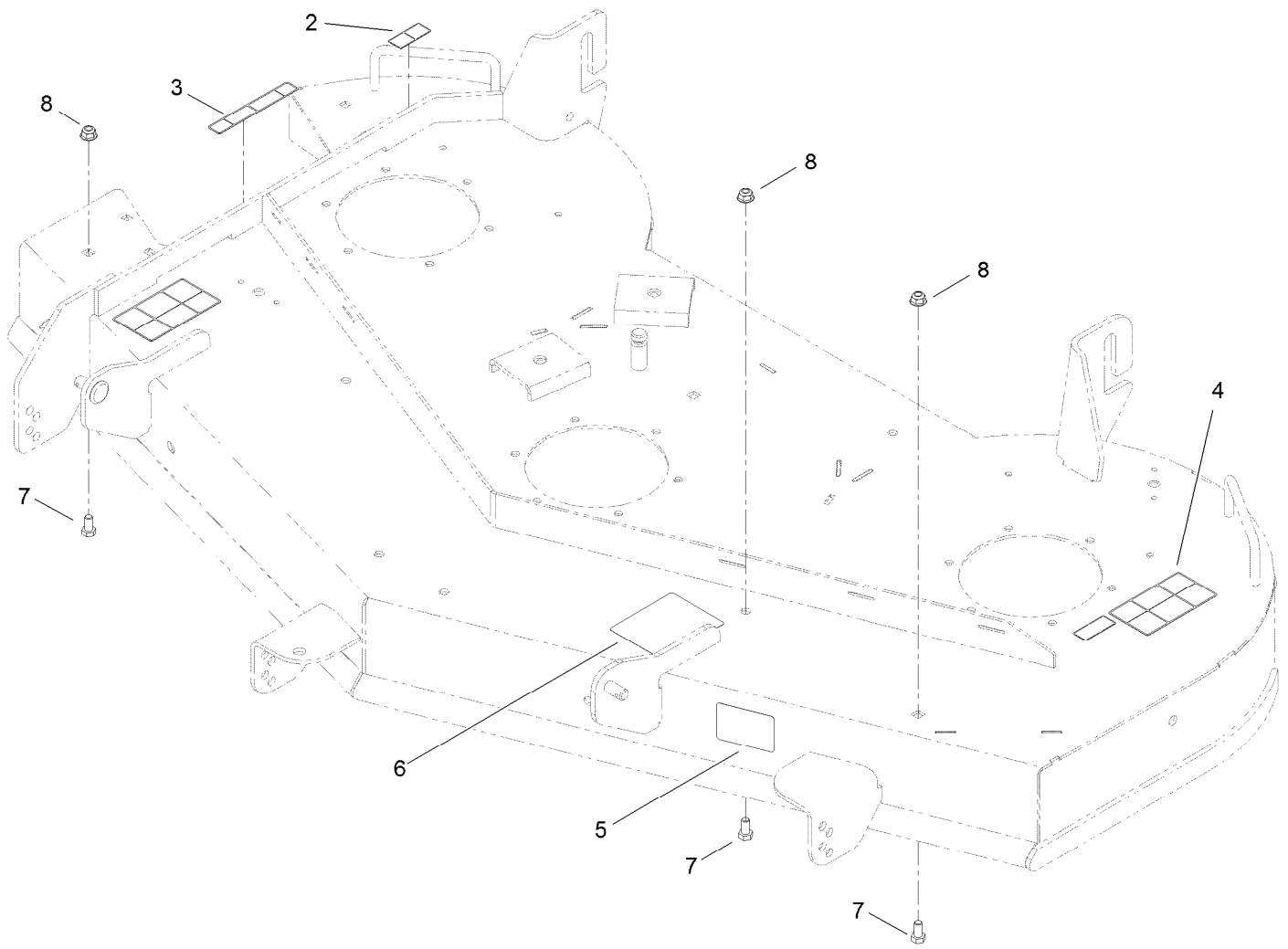

54 Inch Deck and Decal Assembly No. 117-5374

<i>Ref.</i>	<i>Part Number</i>	<i>Qty.</i>	<i>Description</i>
2	114-1606	2	Decal-Danger, Pulley
3	93-7009	1	Decal-Danger, Deflector
4	110-6691	2	Decal-Danger
5	112-9840	1	Decal-Scalp, Anti
6	117-1194	1	Decal-Routing, Belt
7	322-2	3	Screw-HH
8	104-8300	3	Nut-Flange, NI

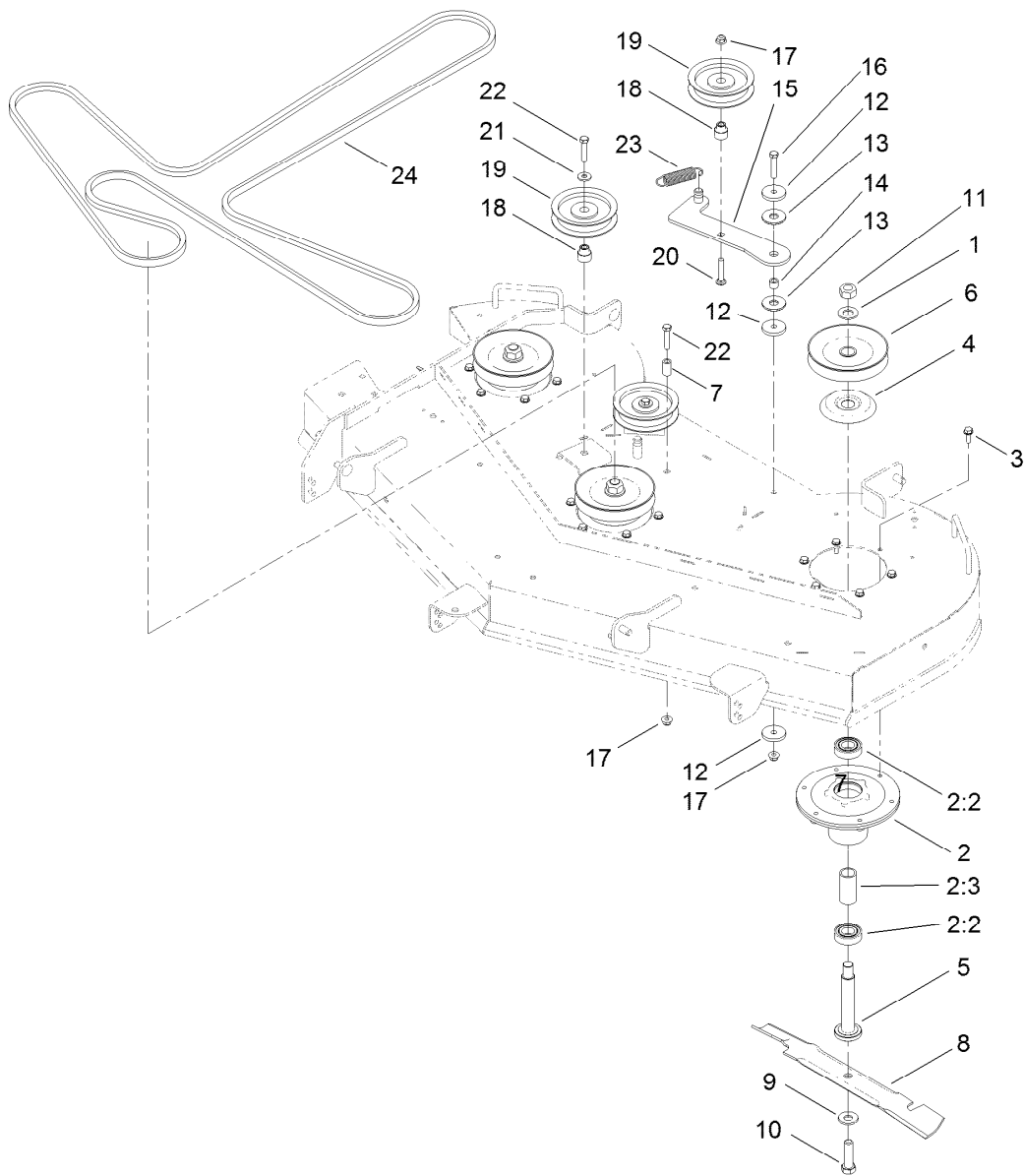

54 Inch Deck Belt and Hi-Flo Blade Assembly

Ref.	Part Number	Qty.	Description	Ref.	Part Number	Qty.	Description
1	7-4150	3	Washer	12	110-9981	3	Washer-Plain
2	120-5477	3	Spindle ASM	13	114-0463	2	Washer-Friction, Composite
2:2	116-0720	2	Bearing-Ball	14	1-413088	1	Bushing-Lever, Lift
2:3	115-2641	1	Spacer-Bearing	15	115-5054	1	Idler Arm ASM
3	32144-41	18	Screw-Taptite	16	323-10	1	Screw-HH
4	117-7210	3	Shield-Bearing	17	104-8301	3	Nut-Flange, NI
5	115-2642	3	Shaft-Spindle	18	115-2577	3	Bushing-Idler
6	115-5018	3	Pulley	19	116-3626	3	Pulley-Idler
7	1-603401	1	Spacer-Fender	20	3231-6	1	Screw-CARR
8	115-9650-03	3	Blade-Hi Flo, 18.75 Inch	21	80-6990	2	Washer-Hardened
9	22-8520	3	Washer-Belleville	22	323-9	3	Screw-HH
10	51-4060	3	Screw-Blade	23	108-4056	1	Spring-Extension
11	3219-7	3	Nut-Hex	24	115-4971	1	V-Belt

Attachments and Accessories

For 74842 TITAN ZX5420 Zero-Turn-Radius Riding Mower

Product Name	Model/Part
54in Recycler Kit.....	117-5313
Step Kit.....	117-5316
Light Kit.....	117-5317
54in/60in Striping Kit.....	117-5319
Leaf Bagging Enhancement Kit	117-7202
Transport Seat Hold Down Kit.....	117-7251
54in Bagger Finishing Kit, 2012 and After TITAN and TimeCutter MX Series Riding Mower.....	121-5663
Hitch Kit	79014
Bagger	79328
10 cu. ft. Poly Dump Cart.....	79991

Notes:

Notes:



Count on it.