



**Count on it.**

**Parts Catalog**

**Commercial Walk-Behind Mower  
Floating Deck, Split Lever, Hydro Drive with  
48in TURBO FORCE® Cutting Unit**

**Model No. 30488—Serial No. 31200001 and Up**

# Ordering Replacement Parts

To order replacement parts, please supply the part number, the quantity, and the description of each part desired.

## Understanding Reference Numbers

Each identified part in an illustration has a reference number. The reference number for a part also appears in the parts list, along with other information about the part.

This catalog uses two special reference number formats, one to indicate parts in a service assembly and another to indicate the quantity of a given part in an illustration.

## Service Assembly Reference Numbers

Parts in service assemblies have reference numbers in the form a:b. The a represents the reference number of the entire service assembly and the b represents a sequential number unique to each part within the service assembly.

For example, a wheel assembly might be identified by reference number 6, the tire by 6:1, the valve by 6:2, and the wheel by 6:3. When you order the assembly identified by reference number 6, you receive all parts identified by reference numbers 6:1, 6:2, and 6:3. However, you may also order any part individually. Reference numbers of this type appear in illustration and in parts lists.

## Reference Numbers Indicating Quantity

In an illustration, if a reference number indicates more than one part, the reference number has the form nX y. The n represents the quantity of the part, the X is the multiplication symbol, and the y represents the reference number.

For example, in an illustration, the reference number 2X 37 means that two of the parts identified by reference number 37 are indicated.

# List of Abbreviations

**AR:** as required

**ASM:** assembly

**BBC:** blade brake control

**BHTF:** button head thread forming

**CARR:** carriage

**CCW:** counter clockwise

**CW:** clockwise

**DEG:** degrees

**DPA:** Dual Point Adjustment

**ECM:** electronic control module

**EXT:** external

**FH:** flat head

**GA:** gauge

**HD:** heavy-duty

**HF:** hex flange

**HH:** hex head

**HHF:** hex head flange

**HHFTF:** hex head flange thread forming

**HJ:** hex jam

**HLH:** hex lag head

**HOC:** height-of-cut

**HSBH:** hex socket button head

**HSFH:** hex socket flat head

**HSH:** hex socket head

**HWH:** hex washer head

**HWTF:** hex washer head thread forming

**HYD:** hydraulic

**LH:** left hand

**LPG:** Liquid Propane Gas

**NI:** nylon insert

**NPTF:** national pipe thread fine

**PFH:** phillips flat head

**PPH:** phillips pan head

**PPHTF:** phillips pan head thread forming

**PRH:** phillips round head

**PTH:** phillips truss head

**PTO:** power-take-off

**RH:** right hand

**ROPS:** roll-over protection system

**RRB:** rear roller brush

**SFH:** slotted fillister head

**SHH:** slotted hex head

**SHWH:** slotted hex washer head

**SPH:** slotted pan head

**SQH:** square head

**SRH:** slotted round head

**STD:** standard

**TAP:** self tapping

**TTH:** torx truss head

# Contents

Engine and Clutch Assembly .....	4
Fuel System Assembly .....	5
Ground Drive Assembly .....	6
Hydraulic Motor Assembly No. 104-1171 .....	7
Hydraulic System Assembly .....	8
Hydraulic Pump Assembly No. 115-4480 .....	9
Hydraulic Pump Assembly No. 115-4481 .....	10
Hydraulic Hose Assembly .....	11
Upper Control Assembly .....	12
Control Panel Assembly .....	13
Electrical System Assembly .....	14
Parking Brake Assembly .....	15
Power-Take-Off Idler and Weight Assembly .....	16
Carrier Frame Assembly .....	17
Deck Drive and Baffle Assembly .....	18
Deck Decal Assembly No. 112-7082 .....	19
Spindle Assembly No. 110-0728 .....	20
Spindle Assembly No. 110-0729 .....	21
Deck Assembly .....	22
Deflector Assembly No. 110-0758 .....	23
Attachments and Accessories .....	24

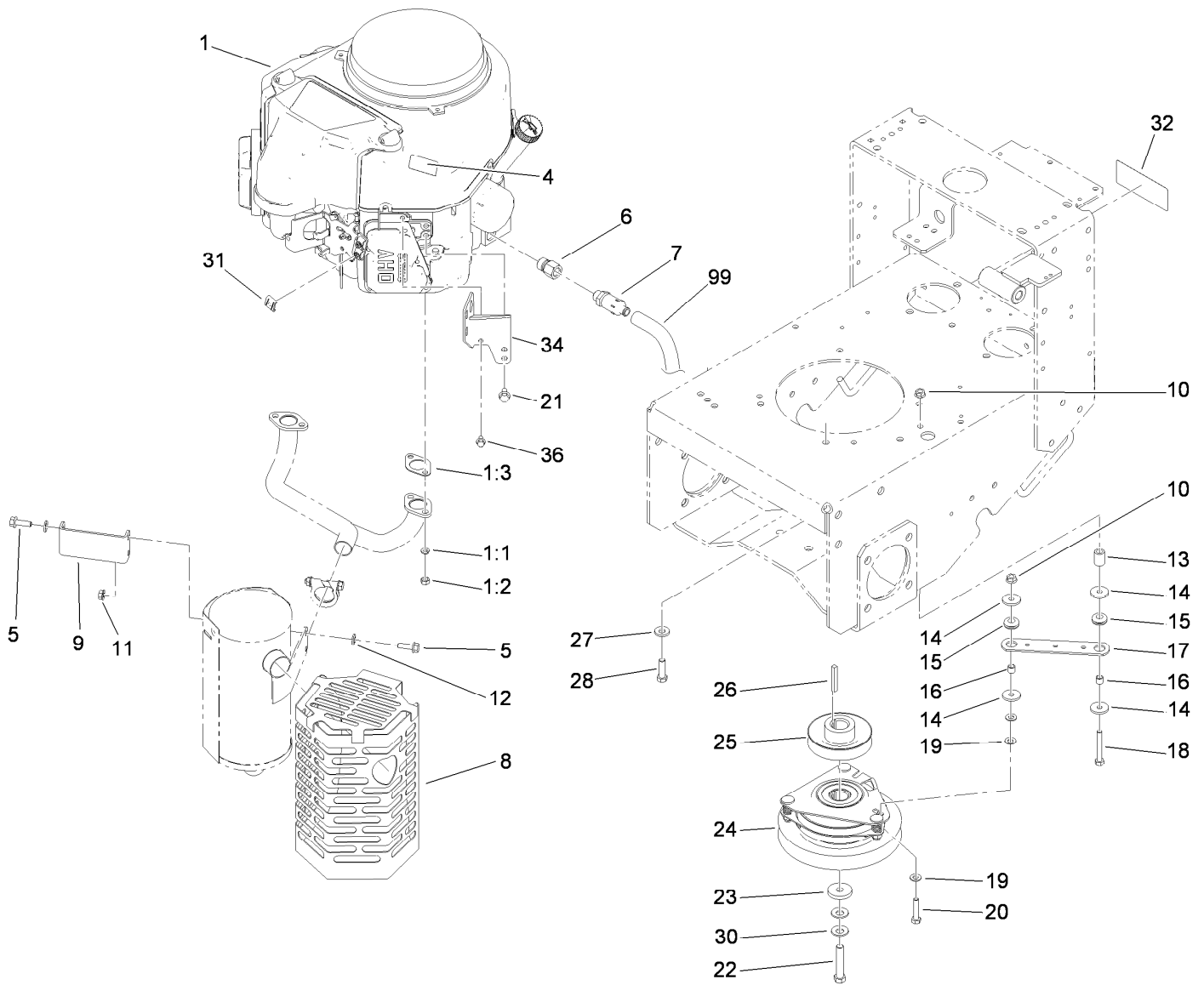

## Engine and Clutch Assembly

Ref.	Part Number	Qty.	Description
1		1	Engine-Kawasaki, Fs600V ● ■
1:1	114-3550	4	Washer-Lock, Spring
1:2	114-3549	4	Nut
1:3	1-653313	2	Gasket-Exhaust
4	106-0699	1	Decal-Warning
5	33104-025	4	Screw-HHF
6	103-1966	1	Adapter
7	92-6877	1	Valve-Drain, Oil
8	119-3629-03	1	Muffler Shield ASM
9	119-3635-03	1	Bracket-Shield, Muffler
10	32128-20	2	Nut-HF
11	117-1350	4	Nut-HF, Lock
12	1-303334	4	Washer-Spring
13	104-6373	1	Tube-Retainer
14	1-613235	4	Washer
15	1-633630	2	Grommet
16	1-633545	2	Spacer

Ref.	Part Number	Qty.	Description
17	1-633543-03	1	Strap-Clutch, Brake
18	322-11	1	Screw-HH
19	3256-23	3	Washer-Flat
20	322-7	1	Screw-HH
21	33104-016	2	Screw-HHF
22	3212-9	1	Screw-HH
23	107-4136	1	Washer
24	105-2635	1	Clutch / Brake ASM
25	44-5940	1	Pulley
26	608006	1	Key-Square
27	98-5975	4	Washer-Belleville
28	323-7	4	Screw-HH
30	1-603610	2	Washer-Spring
31	81-1690	1	Clamp-Cable
32	98-0776	1	Decal-Caution
34	117-8561-03	1	Bracket-Muffler
36	33103-012	1	Screw-HHF
99	103-1964	1	Hose-Drain, Oil

● Not serviced separately

■ Obtain parts from [www.kawpowerpc.com](http://www.kawpowerpc.com)

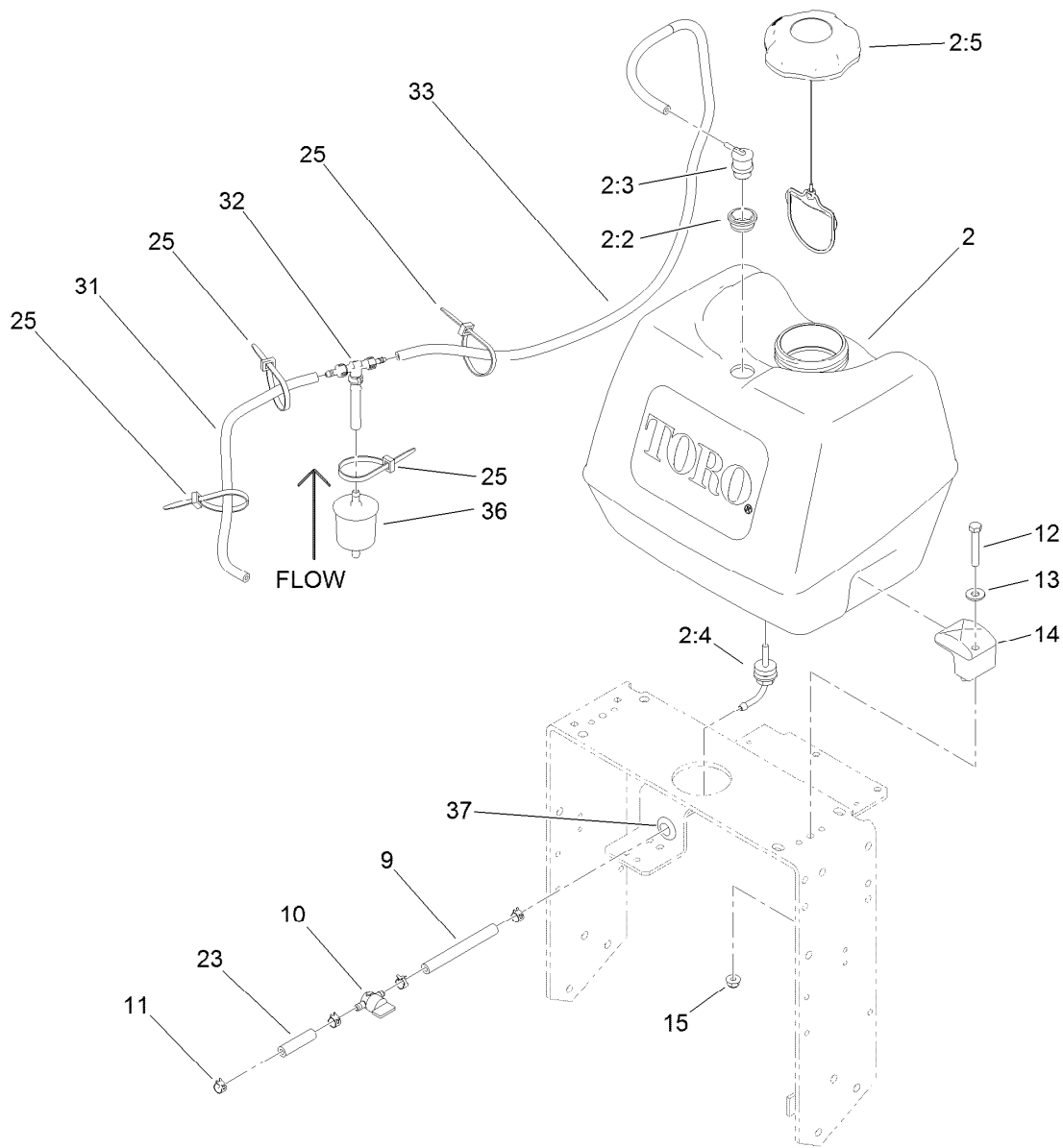

## Fuel System Assembly

<i>Ref.</i>	<i>Part Number</i>	<i>Qty.</i>	<i>Description</i>	<i>Ref.</i>	<i>Part Number</i>	<i>Qty.</i>	<i>Description</i>
2	119-7899	1	Fuel Tank ASM	14	107-4543	2	Clamp
2:2	114-0284	1	Grommet	15	104-8300	2	Nut-Flange, NI
2:3	114-0285	1	Valve-Rollover	23	99-9415	1	Hose-Fuel
2:4	103-2605	1	Fitting-Fuel, Bulkhead	25	3290-378	4	Tie-Cable
2:5	120-5461	1	Cap-Fuel, Ratcheting	31	115-7872	1	Hose-Fuel
9	109-0650	1	Hose-Fuel	32	116-5464	1	Tee And Check ASM
10	1-603770	1	Valve-Fuel	33	116-4346	1	Hose-Emissions
11	2412-98	4	Clamp-Hose	36	120-2235	1	Filter-Air
12	322-10	2	Screw-HH	37	112-7069	1	Grommet
13	3256-3	2	Washer-Flat				

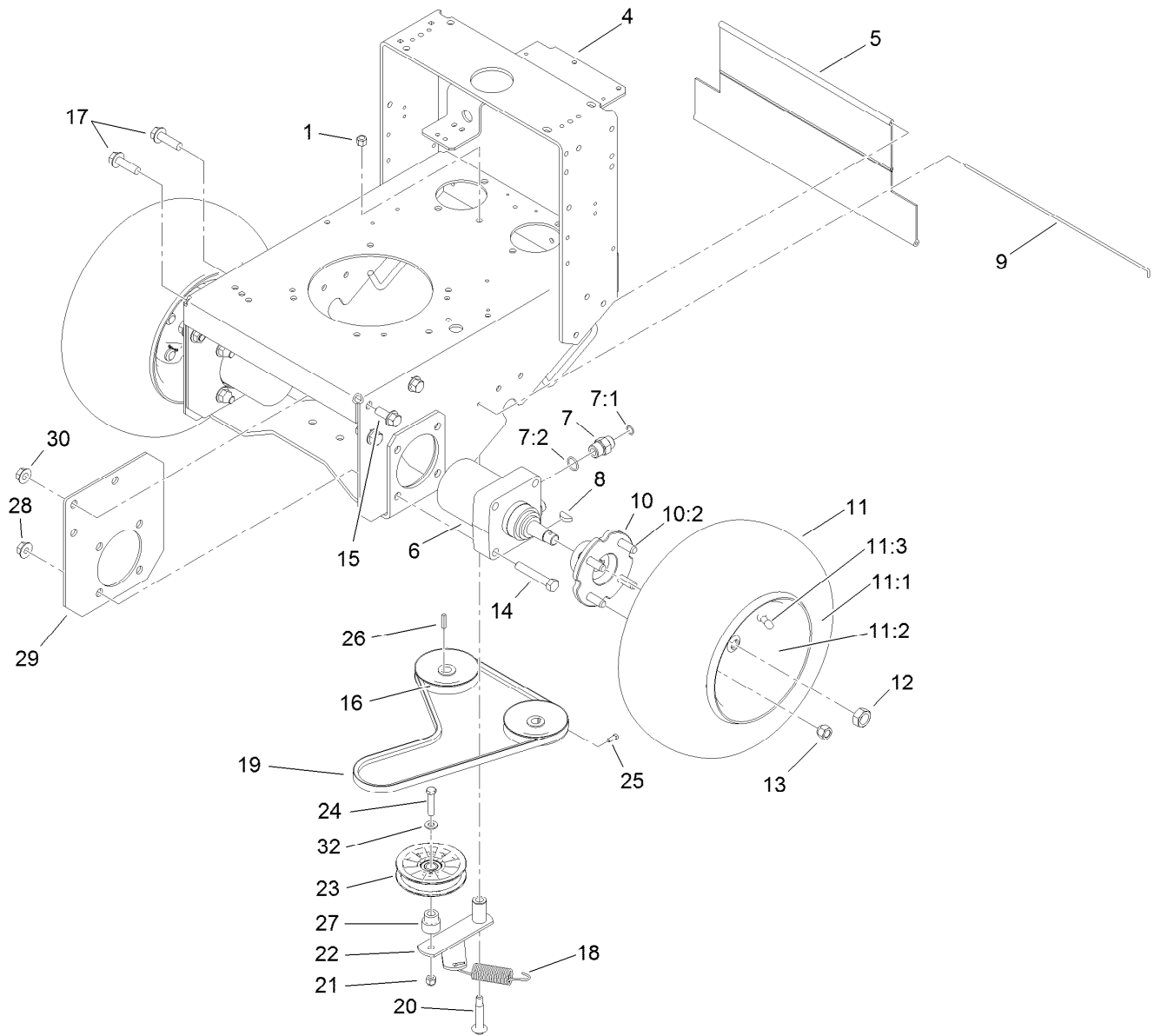

## Ground Drive Assembly

Ref.	Part Number	Qty.	Description	Ref.	Part Number	Qty.	Description
1	3296-6	1	Nut-Lock	15	3234-32	4	Screw-HHF
4	117-3527-01	1	Hydro Frame ASM	16	105-5648	2	Pulley-Pump
5	95-1526	1	Shield-Trailing	17	3234-22	2	Screw-HHF
6	104-1171	2	HYD Motor ASM	18	68-9950	1	Spring-Traction
7	340-6	4	Fitting-HYD, Straight	19	110-5049	1	Belt-V
7:1	237-30	1	O-Ring	20	27-6230	1	Bolt-Wheel
7:2	237-80	1	O-Ring	21	3296-39	1	Nut-Lock, NI
8	3257-8	2	Key-Woodruff	22	86-4770	1	Idler Lever ASM
9	95-1529	1	Rod-Shield	23	109-4077	1	Pulley-Idler, Flat
10	105-0800	2	Wheel Hub ASM	24	323-9	1	Screw-HH
10:2	10-6830	4	Stud-Type, Drive	25	3241-5	4	Screw-Set
11	104-1198	2	Wheel And Tire ASM	26	1-807272	2	Key
11:1	104-6320	1	Tire	27	1-603496	1	Bushing-Idler
11:2	104-1199	1	Wheel	28	32128-49	8	Nut-HHF
11:3	232-27	1	Stem-Valve	29	108-6657-01	2	Plate-Frame
12	85-7310	2	Nut-Motor, Wheel	30	32128-23	6	Nut-HF
13	242-50	8	Nut-Lug	32	3256-24	1	Washer-Flat
14	325-12	8	Screw-HH				

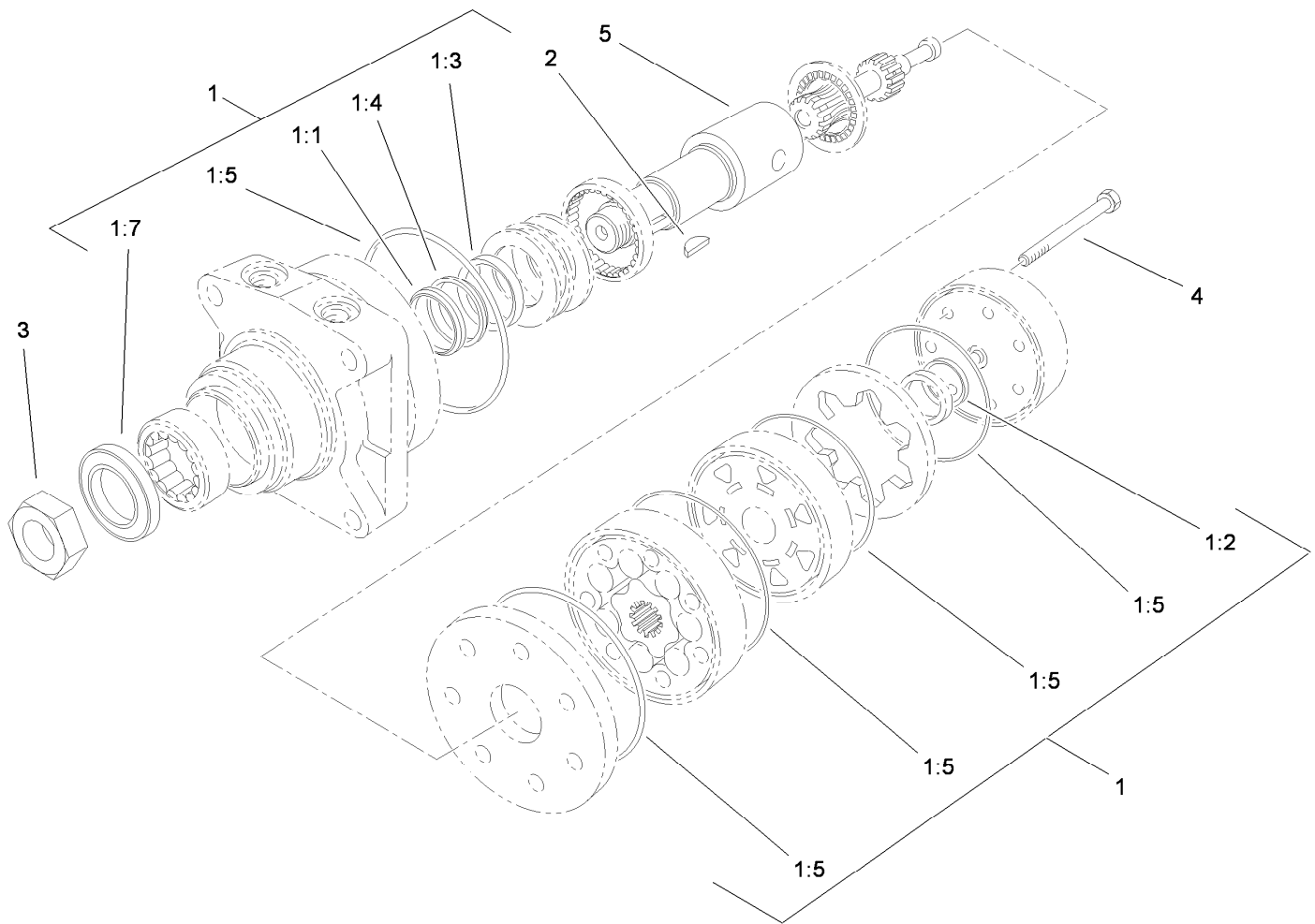

## Hydraulic Motor Assembly No. 104-1171

Ref.	Part Number	Qty.	Description
1	1-000119	1	Seal Kit
1:1		1	Ring-Back Up ●
1:2		1	Seal-Commutator ●
1:3		1	Seal-Shaft (Viton) ●
1:4		1	Washer-Back Up, Steel ●
1:5		5	Ring-Seal (Viton) ●
1:7		1	Seal-Dirt And Water ●
2	3257-8	1	Key-Woodruff
3	85-7310	1	Nut-Motor, Wheel
4	106-5549	6	Bolt-Special
5	106-8764	1	Shaft-Coupling

● Not serviced separately

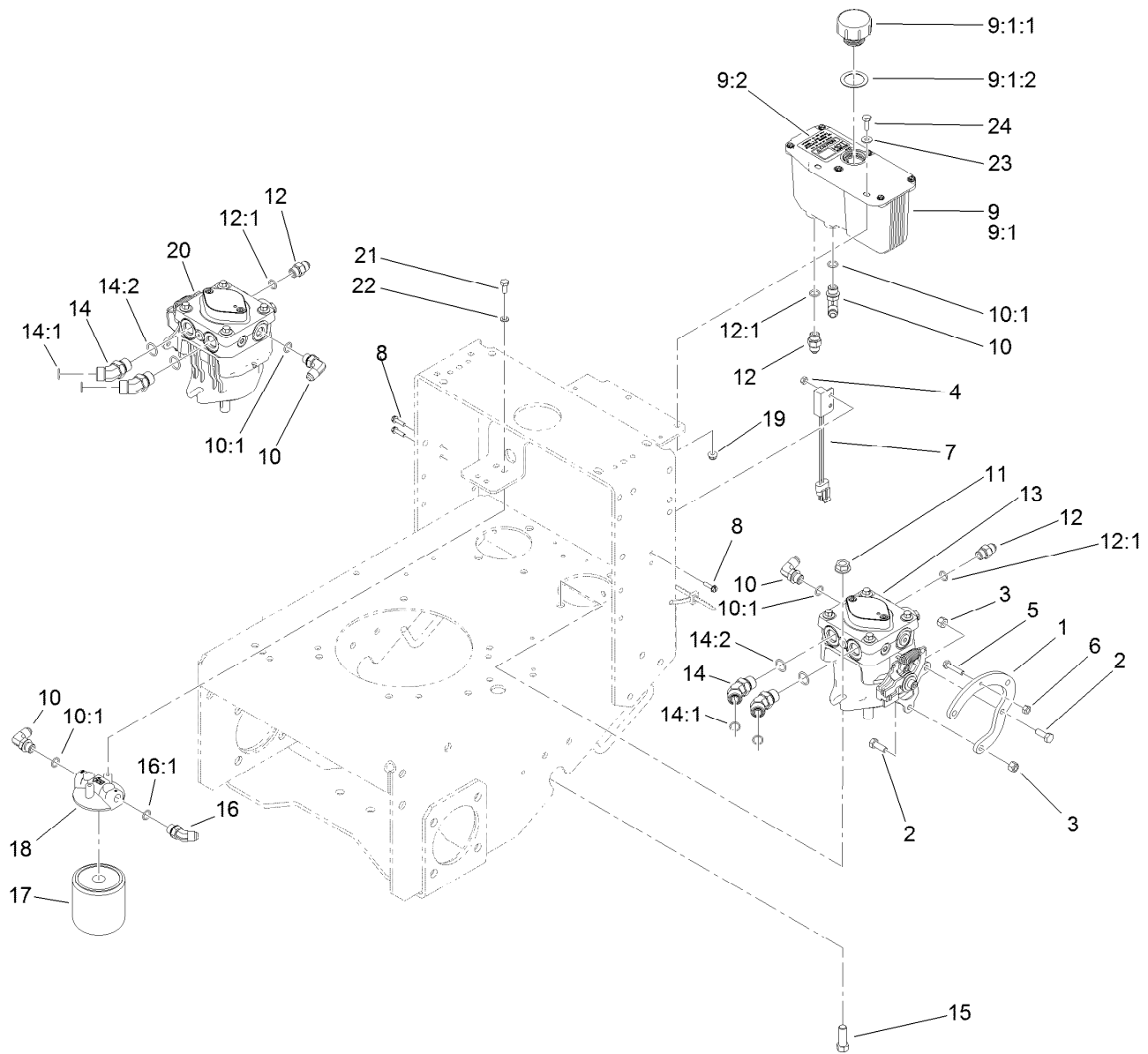

## Hydraulic System Assembly

Ref.	Part Number	Qty.	Description	Ref.	Part Number	Qty.	Description
1	114-0227	2	Bracket-Adapter, Pump	12:1	237-42	1	O-Ring
2	322-4	4	Screw-HH	13	115-4480	1	HYD Pump ASM
3	3296-29	4	Nut-Lock, NI	14	340-101	4	Fitting-HYD, 45 DEG
4	3296-2	4	Nut-Lock, NI	14:1	237-30	1	O-Ring
5	114-0282	2	Screw-HH	14:2	237-79	1	O-Ring
6	3217-5	2	Nut-Hex	15	324-5	4	Screw-HH
7	105-0023	2	Switch-Proximity	16	353-212	1	Fitting-HYD, 45 DEG
8	32105-13	4	Screw-HWH	16:1	237-42	1	O-Ring
9	107-8433	1	HYD Reservoir ASM	17	1-633750	1	Filter-Oil, HYD
9:1		1	Reservoir-HYD ●	17	1-633752	1	Filter-Oil, HYD (Winter)
9:1:1	103-1948	1	Cap-Reservoir, HYD	18	104-7836	1	Head-Filter
9:1:2	103-1949	1	Gasket-Cap	19	104-7201	2	Nut-HF
9:2	115-4212	1	Decal-Warning	20	115-4481	1	HYD Pump ASM
10	353-374	4	Elbow-90 DEG	21	321-3	2	Screw-HH
10:1	237-42	1	O-Ring	22	3253-3	2	Washer-Lock
	32128-42	4	Nut-HF	23	3256-22	2	Washer-Flat
12	353-384	3	Fitting-Straight	24	321-6	2	Screw-HH

● Not serviced separately

99-Seal Overhaul Kit

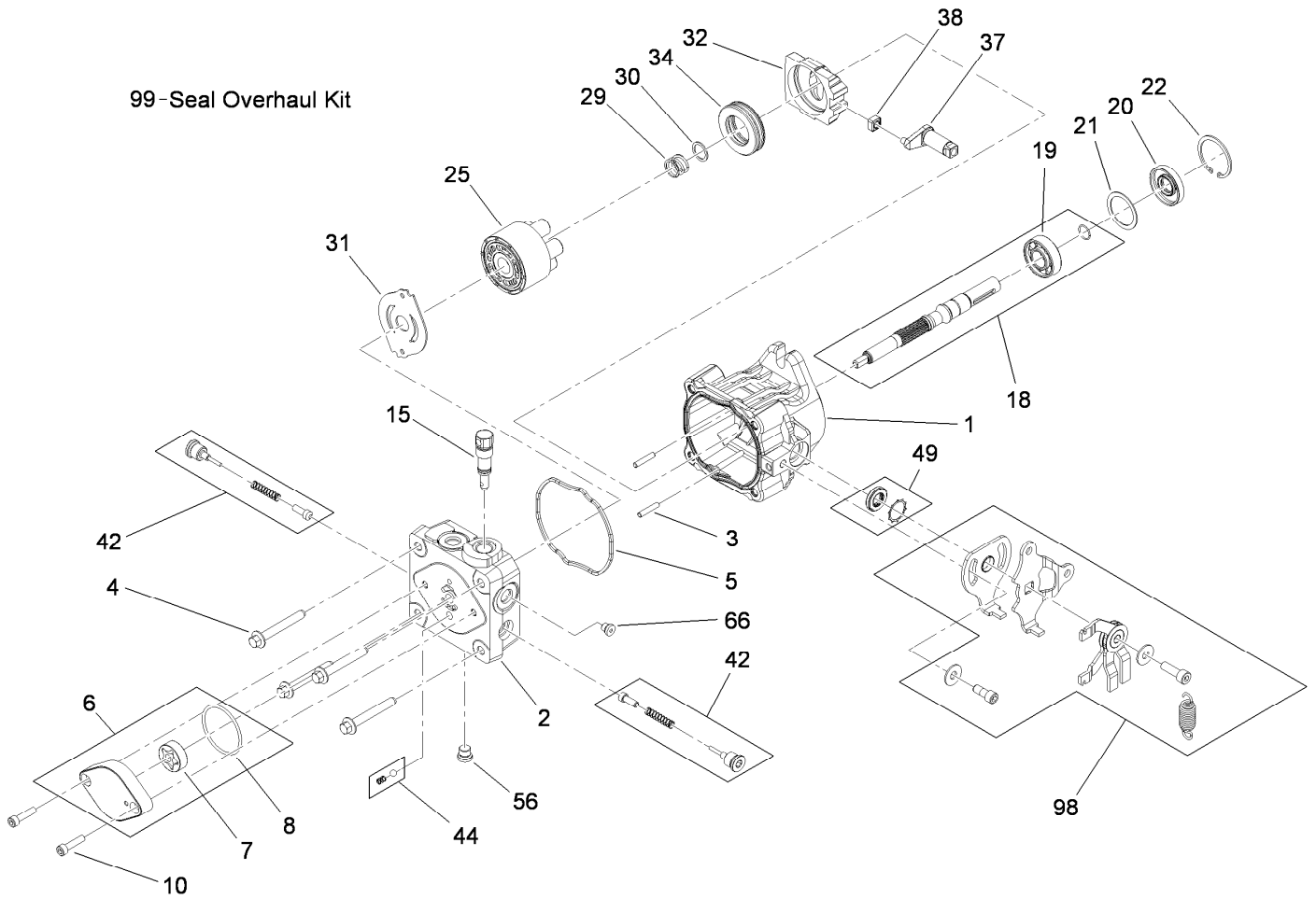

## Hydraulic Pump Assembly No. 115-4480

Ref.	Part Number	Qty.	Description	Ref.	Part Number	Qty.	Description
1	115-4464	1	Housing Kit	29	94-1936	1	Spring-Block
2	106-8752	1	End Cap Kit (W/Poppets)	30	94-1937	1	Washer-Thrust, Block
3	106-8753	2	Pin-Headless, Straight	31	105-6185	1	Plate-Valve
4	106-8754	4	Bolt-HF	32	94-1907	1	Swashplate-Variable
5	106-8755	1	O-Ring	34	94-6922	1	Bearing-Thrust
6	106-8756	1	Charge Pump Kit	37	115-4458	1	Arm-Trunnion, Tapered Square
7	104-2122	1	Gerotor ASM	38	94-1910	1	Guide-Slot
8	106-8757	1	O-Ring	42	98-3252	2	Valve-Check (W/Poppet)
10	104-2111	2	Capscrew	44	106-8760	1	Charge Relief Valve Kit
15	106-8759	1	Bypass Valve Kit	49	114-8155	1	Trunnion Seal Kit
18	103-2664	1	Input Shaft Kit	56	106-8762	1	Plug-HSH
19	104-5311	1	Bearing-Ball	66	106-8763	1	Plug-HSH
20	104-5310	1	Seal-Lip	98	115-4459	1	Kit-Return
21	104-5308	1	Spacer	99	105-6184	1	Seal Overhaul Kit
22	104-5309	1	Ring-Retaining				
25	103-2666	1	Cylinder Block Kit				

99-Seal Overhaul Kit

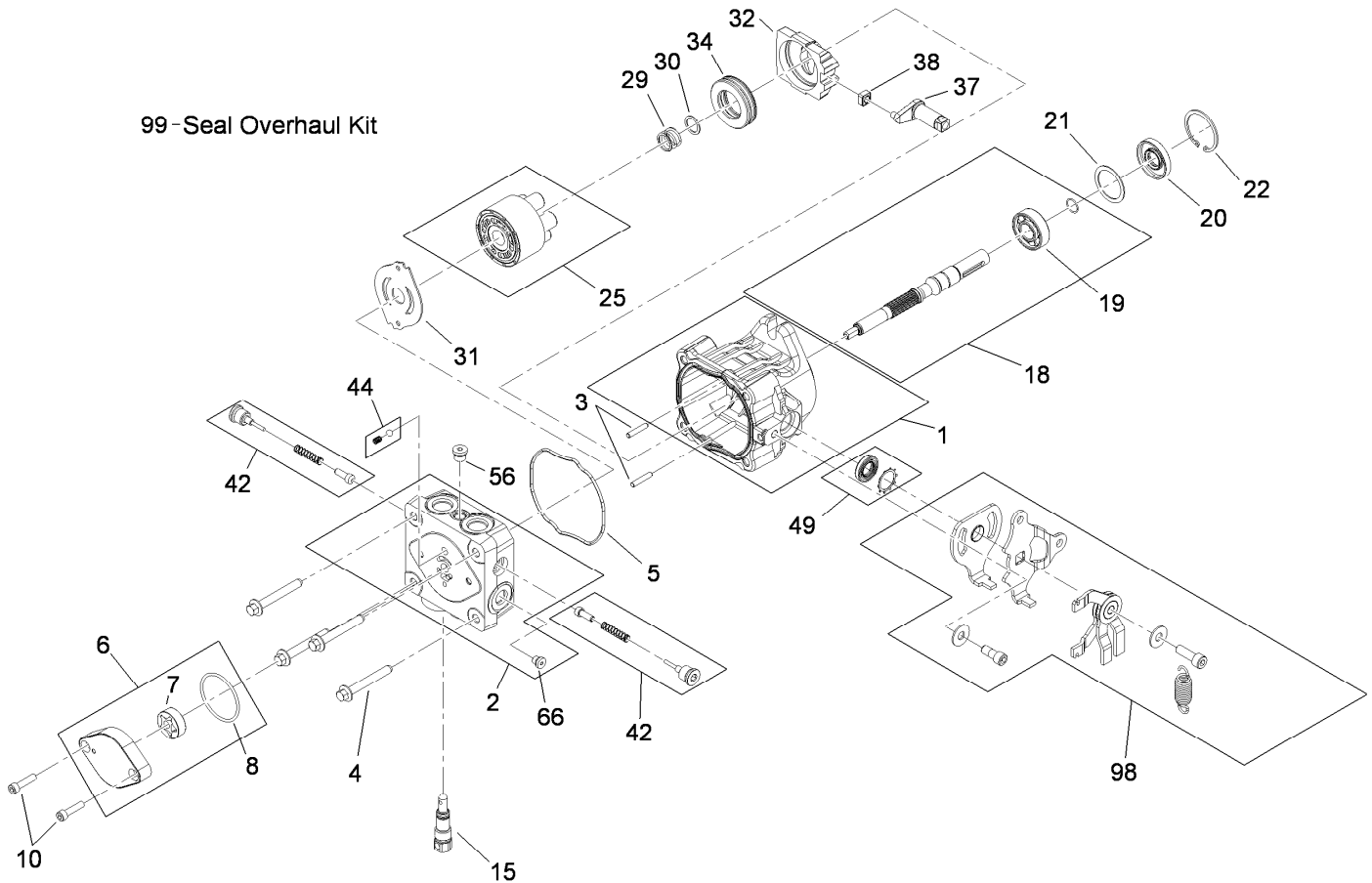

## Hydraulic Pump Assembly No. 115-4481

Ref.	Part Number	Qty.	Description	Ref.	Part Number	Qty.	Description
1	115-4464	1	Housing Kit	29	94-1936	1	Spring-Block
2	106-8752	1	End Cap Kit (W/Poppets)	30	94-1937	1	Washer-Thrust, Block
3	106-8753	2	Pin-Headless, Straight	31	105-6185	1	Plate-Valve
4	106-8754	4	Bolt-HF	32	94-1907	1	Swashplate-Variable
5	106-8755	1	O-Ring	34	94-6922	1	Bearing-Thrust
6	106-8756	1	Charge Pump Kit	37	115-4458	1	Arm-Trunnion, Tapered Square
7	104-2122	1	Gerotor ASM	38	94-1910	1	Guide-Slot
8	106-8757	1	O-Ring	42	98-3252	2	Valve-Check (W/Poppet)
10	104-2111	2	Capscrew	44	106-8760	1	Charge Relief Valve Kit
15	106-8759	1	Bypass Valve Kit	49	114-8155	1	Trunnion Seal Kit
18	103-2664	1	Input Shaft Kit	56	106-8762	1	Plug-HSH
19	104-5311	1	Bearing-Ball	66	106-8763	1	Plug-HSH
20	104-5310	1	Seal-Lip	98	115-4459	1	Kit-Return
21	104-5308	1	Spacer	99	105-6184	1	Seal Overhaul Kit
22	104-5309	1	Ring-Retaining				
25	103-2666	1	Cylinder Block Kit				

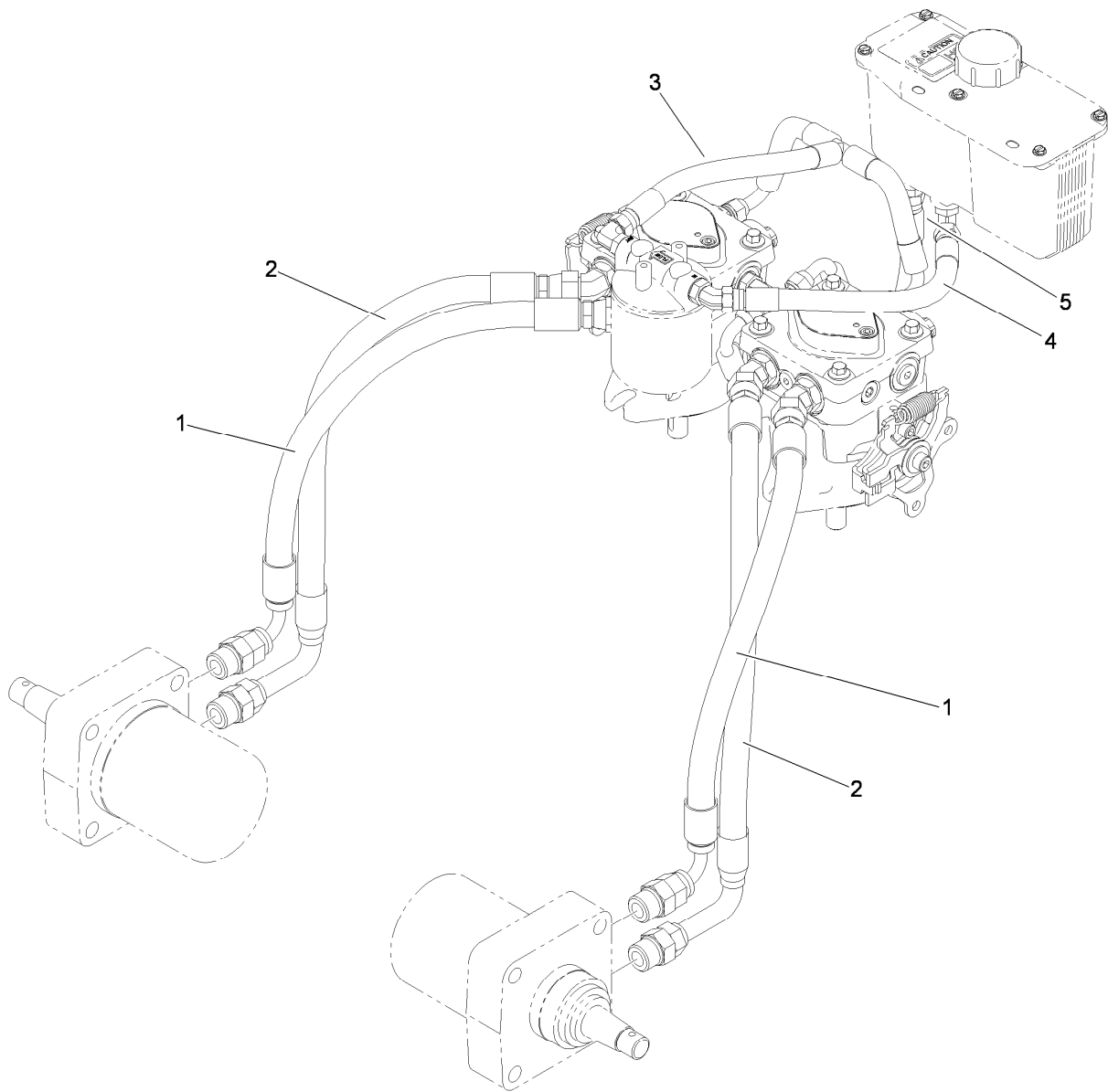

## Hydraulic Hose Assembly

<i>Ref.</i>	<i>Part Number</i>	<i>Qty.</i>	<i>Description</i>
1	112-9704	2	HYD Hose ASM
2	114-3430	2	HYD Hose ASM
3	105-5697	1	HYD Hose ASM
4	105-5699	1	HYD Hose ASM
5	114-3434	1	HYD Hose ASM

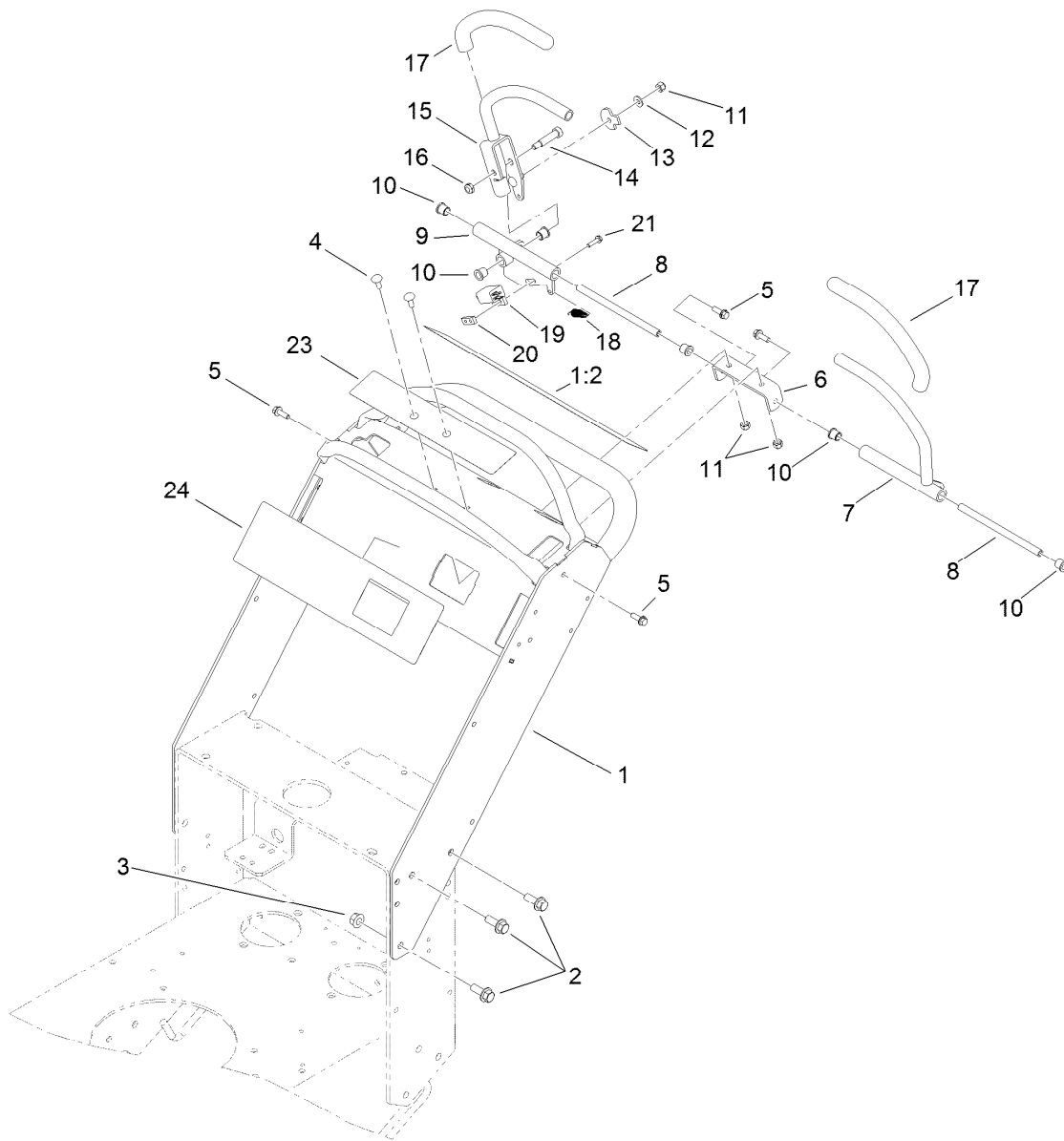

## Upper Control Assembly

<i>Ref.</i>	<i>Part Number</i>	<i>Qty.</i>	<i>Description</i>	<i>Ref.</i>	<i>Part Number</i>	<i>Qty.</i>	<i>Description</i>
1	115-4200	1	T-Bar Handle ASM	12	3256-22	1	Washer-Flat
1:2	115-4179	1	Decal-Warning, Control	13	114-0268	1	Cam-Lever
2	3234-11	6	Screw-HHF	14	114-0239	1	Screw-HSH
3	32128-21	6	Nut-HF	15	114-0238-03	1	Lever ASM
4	3229-1	2	Screw-CARR	16	3296-47	1	Nut-Lock, NI
5	3234-4	4	Screw-HHF	17	119-0222	2	Grip
6	114-0235	1	Bracket-Support	18	114-0249	1	Spring-Extension
7	114-0272-03	1	Control Lever ASM	19	1-513152	1	Switch-Closed, Normally
8	119-1885	2	Shaft-Pivot, Motion Control	20	1-633181	1	Plate-Tapped
9	114-0234	1	Motion Control ASM	21	32105-13	2	Screw-HWH
10	103-9928	6	Bearing	23	114-3424	1	Decal-Control
11	3296-42	3	Nut-Lock, NI	24	115-4189	1	Decal-Panel, Control

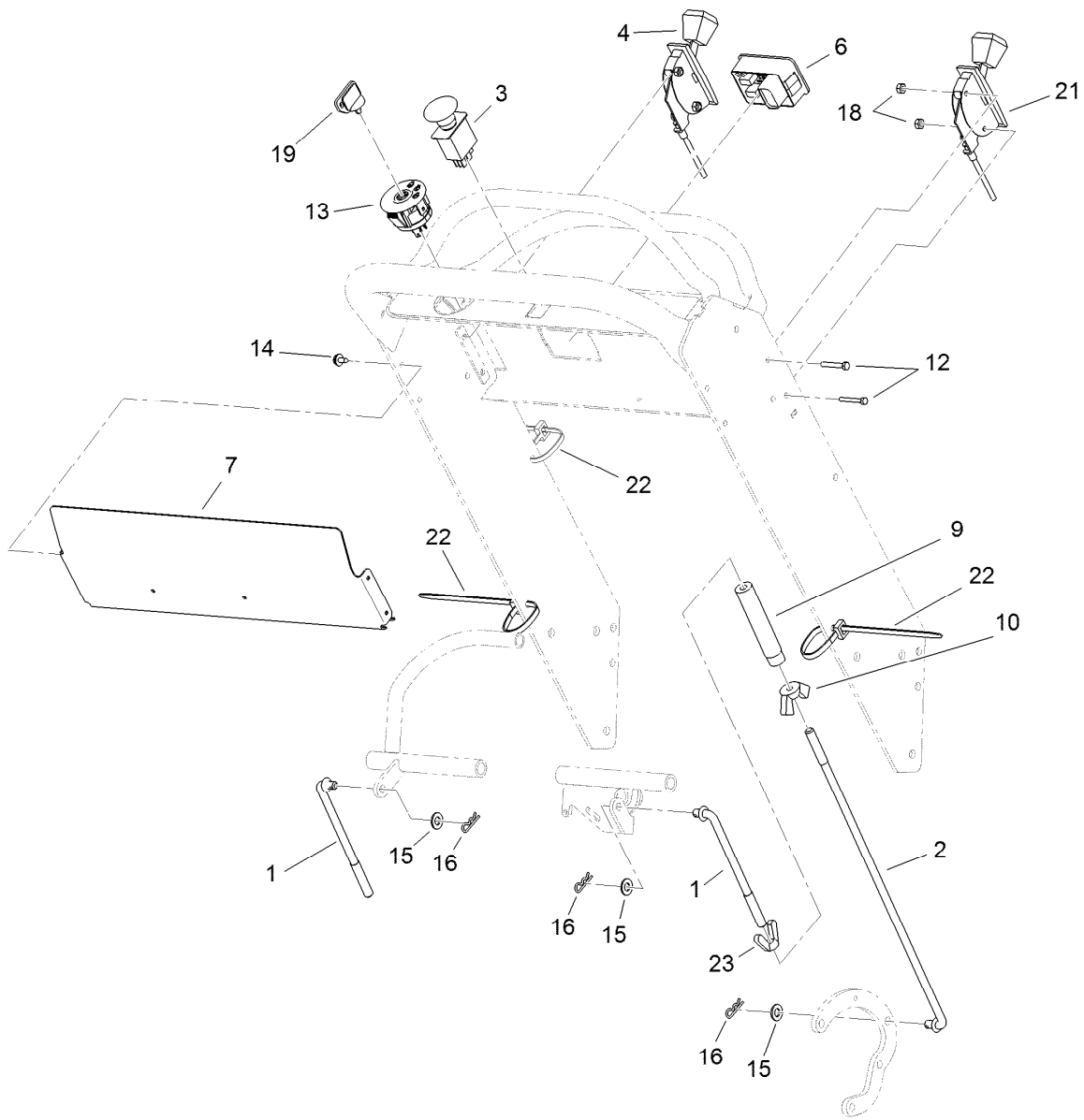

## Control Panel Assembly

<i>Ref.</i>	<i>Part Number</i>	<i>Qty.</i>	<i>Description</i>	<i>Ref.</i>	<i>Part Number</i>	<i>Qty.</i>	<i>Description</i>
1	114-0275	2	Rod-Control, Upper	13	116-0050	1	Switch-Ignition
2	114-0276	2	Rod-Control, Lower	14	32104-76	4	Screw
3	114-0279	1	Switch-PTO	15	3256-23	4	Washer-Flat
4	119-6539	1	Cable-Throttle	16	3290-307	4	Pin-Hair
6	117-3886	1	Module-Hour Meter	18	3296-2	4	Nut-Lock, NI
7	114-0270-03	1	Cover-Panel, Control	19	63-8360	1	Key-Ignition
9	95-1504	2	Turnbuckle	21	110-4995	1	Cable-Choke
10	32103-3	2	Nut-Wing	22	3290-378	3	Tie-Cable
12	3290-360	4	Screw-HH	23	114-0281	2	Nut-Wing, LH

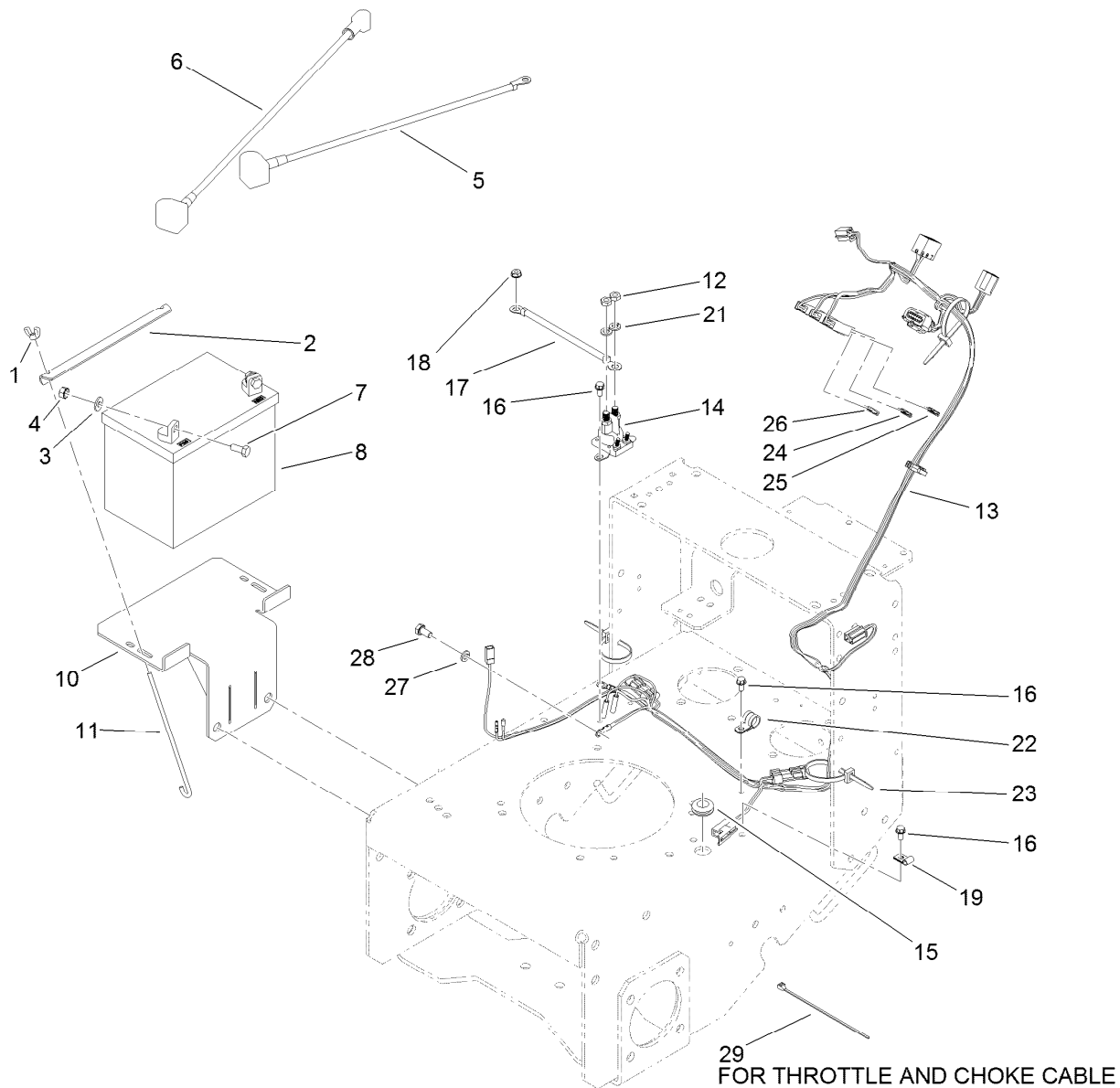

## Electrical System Assembly

<i>Ref.</i>	<i>Part Number</i>	<i>Qty.</i>	<i>Description</i>	<i>Ref.</i>	<i>Part Number</i>	<i>Qty.</i>	<i>Description</i>
1	1-543792	2	Wingnut	15	112-7069	1	Grommet
2	103-9944-03	1	Angle-Battery	16	32144-4	4	Screw-HWH
3	3256-2	2	Washer-Flat	17	112-9707	1	Cable-Battery, Pos
4	32149-1	2	Nut-Keps	18	32149-2	1	Nut-Keps
5	112-9709	1	Cable-Battery, Black	19	2412-72	1	Clip-Closed, Insulated
6	112-9708	1	Cable-Battery, Red	21	3253-4	2	Washer-Lock
7	322-3	2	Screw-HH	22	2412-134	1	Clamp-R
8	104-8162	1	Battery	23	3290-378	3	Tie-Cable
10	117-5216-01	1	Battery Tray ASM	24	109102	1	Fuse-Blade, 25 Amp
11	1-633651	2	Bolt-Holddown	25	109103	1	Fuse-Blade, 30 Amp
12	3220-2	2	Nut-Jam	26	218-578	1	Fuse-Blade, 10 Amp
13	115-4191	1	Harness-Wire, Es Twin Lever	27	3253-4	1	Washer-Lock
14	1-513075	1	Switch-Solenoid	28	33114-016	1	Screw-HH
				29	1-303287	1	Tie-Cable

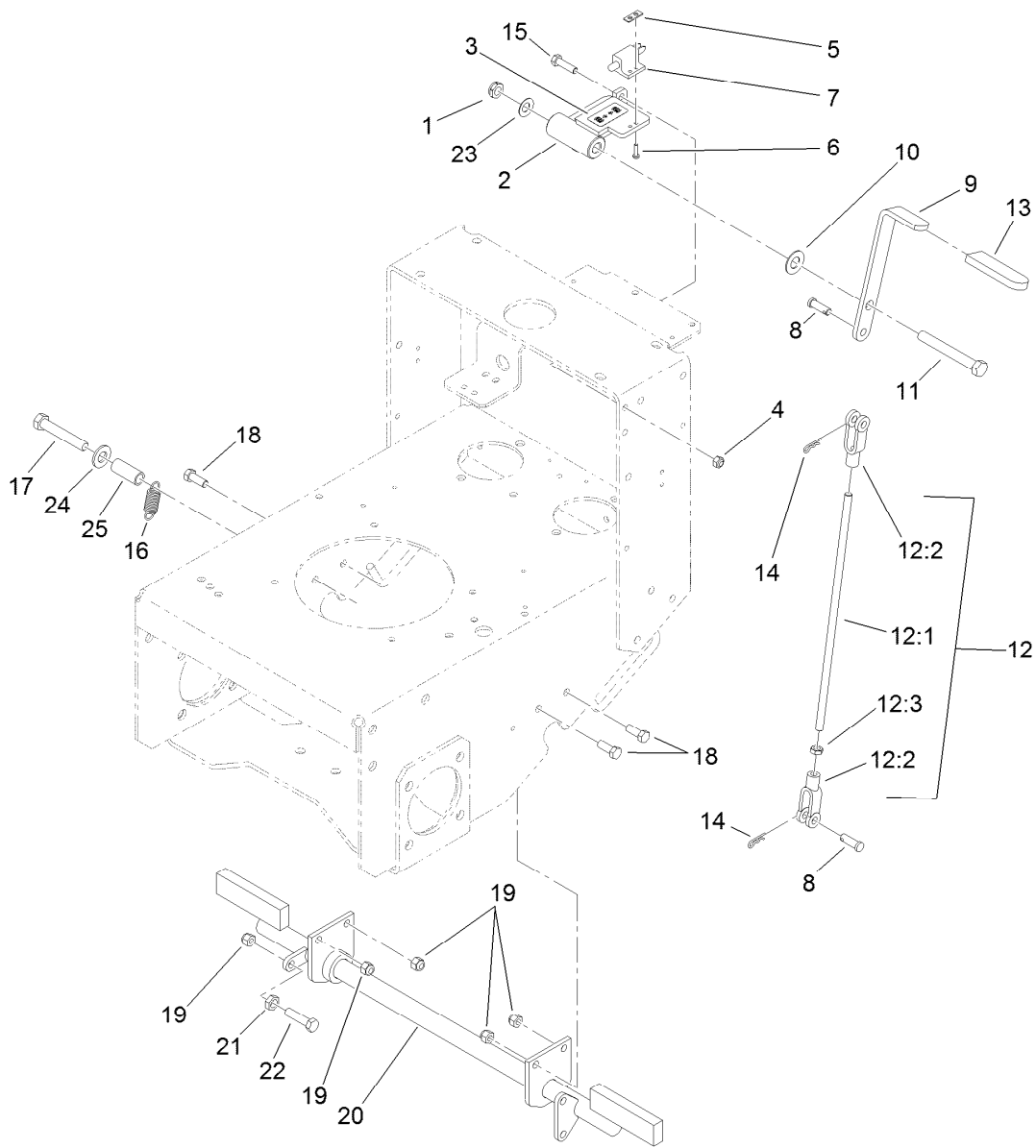

## Parking Brake Assembly

Ref.	Part Number	Qty.	Description	Ref.	Part Number	Qty.	Description
1	3296-45	1	Nut-Lock, NI	12:3	3219-3	1	Nut-Hex
2	112-8716-01	1	Support-Handle	13	1-303020	1	Grip-Lever
3	112-8720	1	Decal-Brake	14	3290-307	2	Pin-Hair
4	3296-29	2	Nut-Lock, NI	15	322-6	2	Screw-HH
5	1-633181	1	Plate-Tapped	16	613386	1	Spring-Brake
6	32105-13	2	Screw-HWH	17	323-11	1	Screw-HH
7	1-513152	1	Switch-Closed, Normally	18	323-6	3	Screw-HH
8	1-808285	2	Pin-Clevis	19	3296-39	5	Nut-Lock, NI
9	106-0671-01	1	Handle-Brake	20	110-4976-01	1	Parking Brake ASM
10	257-7	1	Bearing-Thrust	21	3218-3	1	Nut-Jam
11	325-17	1	Screw-HH	22	323-8	1	Screw-HH
12	115-1465	1	Brake Rod ASM	23	112-9972	1	Washer-Conical, Spring
12:1	108-2747	1	Rod-Brake	24	3256-24	1	Washer-Flat
12:2	1-633131	2	Yoke-Linkage, Brake	25	114-1337	1	Spacer-Spring

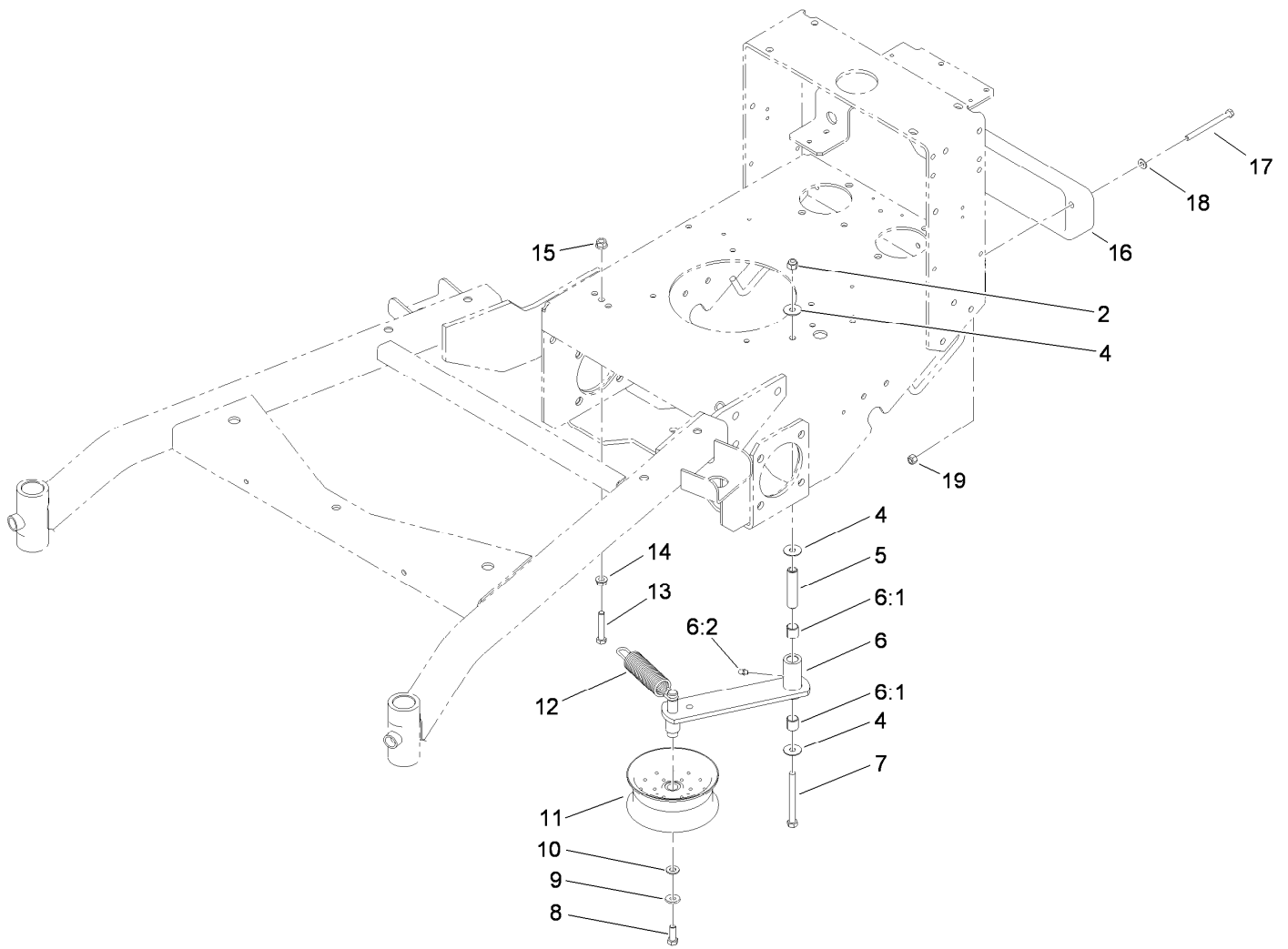

## Power-Take-Off Idler and Weight Assembly

<i>Ref.</i>	<i>Part Number</i>	<i>Qty.</i>	<i>Description</i>	<i>Ref.</i>	<i>Part Number</i>	<i>Qty.</i>	<i>Description</i>
2	3296-39	1	Nut-Lock, NI	11	116-4666	1	Idler-Pulley, Flat
4	52-2860	3	Washer	12	105-8443	1	Spring-Extension
5	104-6377	1	Tube-Idler	13	323-10	1	Screw-HH
6	108-2734	1	Idler Arm ASM	14	3290-357	1	Nut-HHF, Whiz
6:1	1-513034	2	Sleeve-Bearing	15	32128-21	1	Nut-HF
6:2	302-5	1	Fitting-Grease	16	112-7059-01	1	Weight-Cast
7	323-42	1	Screw-HH	17	322-9	2	Screw-HH
8	323-6	1	Screw-HH	18	3256-23	2	Washer-Flat
9	98-5975	1	Washer-Belleville	19	3296-29	2	Nut-Lock, NI
10	3256-24	1	Washer-Flat				

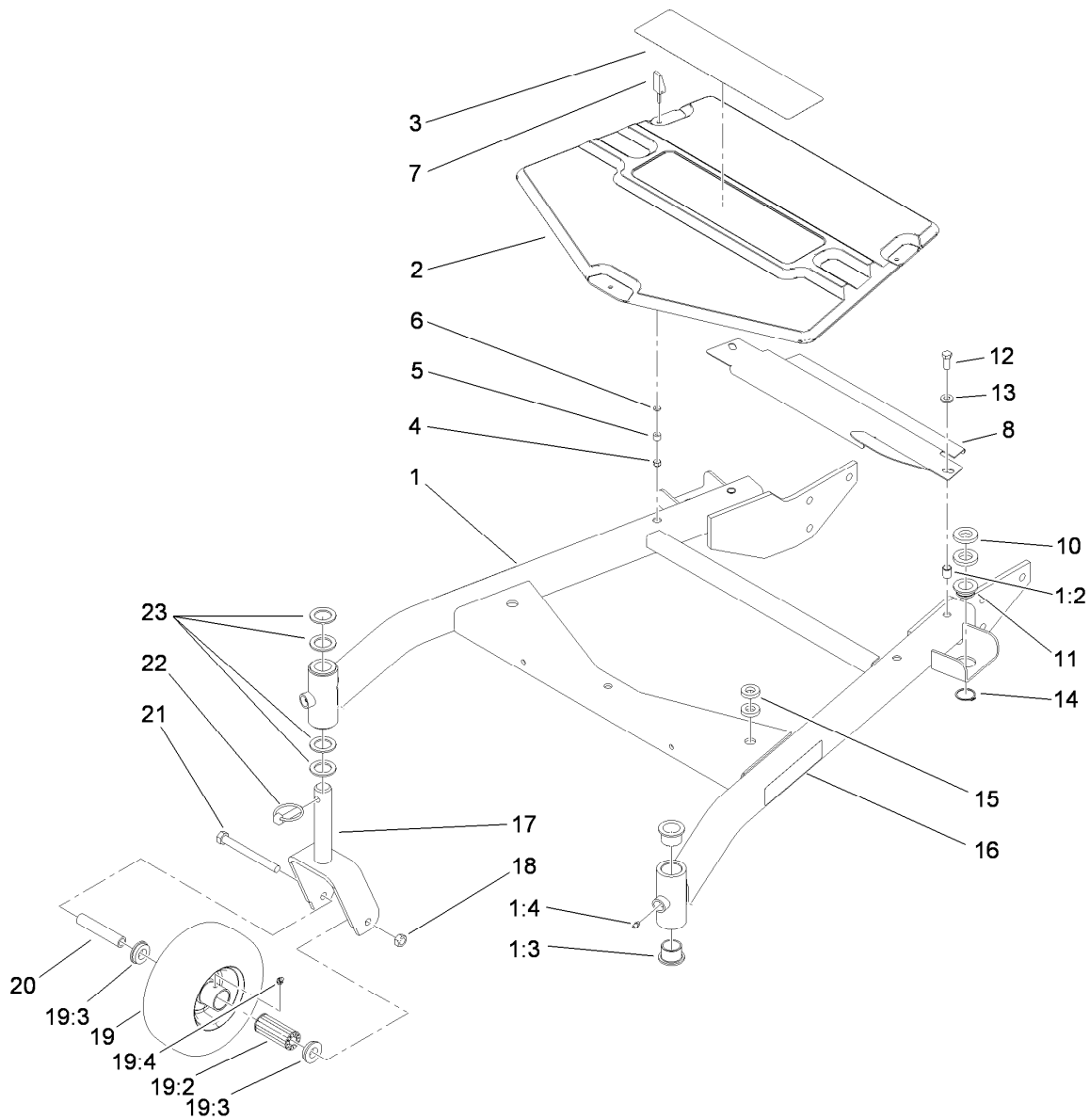

## Carrier Frame Assembly

<i>Ref.</i>	<i>Part Number</i>	<i>Qty.</i>	<i>Description</i>	<i>Ref.</i>	<i>Part Number</i>	<i>Qty.</i>	<i>Description</i>
1	108-2665	1	Carrier Frame ASM	13	3256-24	2	Washer-Flat
1:2	32148-9	2	Insert-Nut	14	32120-33	2	Ring-Retaining
1:3	94-1291	4	Bushing	15	1-323539	4	Spacer
1:4	302-5	2	Fitting-Grease	16	106-0635	2	Decal-HOC
2	108-6625	1	Cover-Frame, Carrier	17	105-3159-01	2	Castor Fork ASM
3	112-9712	1	Decal	18	32153-5	2	Nut-Hex
4	1-804254	3	Nut-Lock, HH	19	110-5024	2	Wheel And Tire ASM
5	106-6778	3	Bushing-Latch, Swell	19:2	112-7066	1	Bearing-Roller
6	99-3058	3	Washer	19:3	1-513810	2	Bushing
7	106-6777	3	Handle-Latch, Swell	19:4	302-61	1	Fitting-Grease
8	119-6534-01	1	Shield-Belt	20	100-6453	2	Bushing-Spanner
10	104-1105	4	Spacer-Support, Deck	21	325-19	2	Screw-HH
11	1-513336	2	Bushing-Deck	22	283-71	2	Pin-Lynch
12	323-6	2	Screw-HH	23	3-6781	8	Washer-Thrust

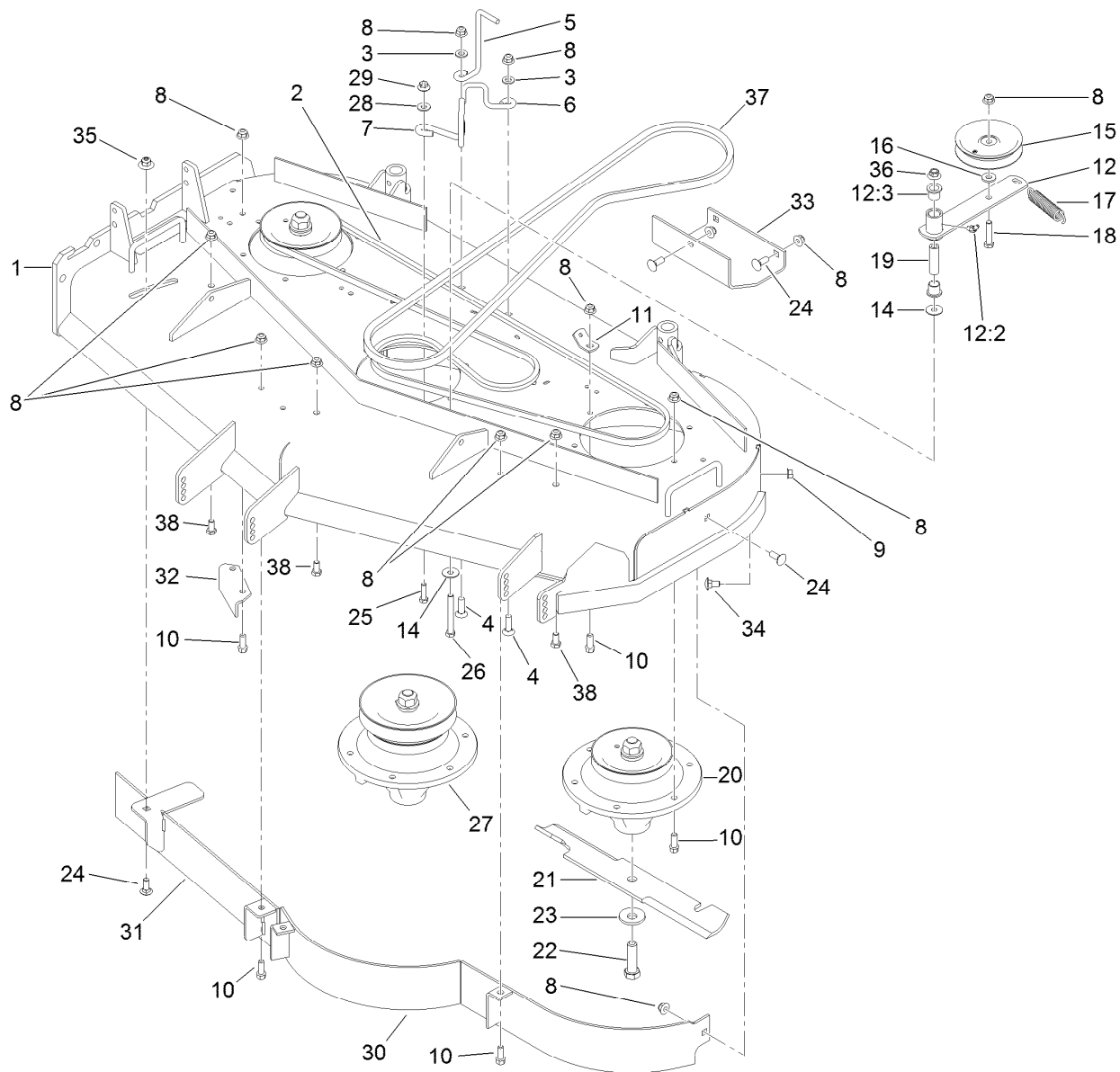

## Deck Drive and Baffle Assembly

Ref.	Part Number	Qty.	Description	Ref.	Part Number	Qty.	Description
1	112-7082	1	Deck ASM	20	110-0728	2	Spindle ASM
2	108-2716	1	Belt-V	21	107-3192-03	3	Blade-16.5 Inch (High Flow)
3	3256-24	2	Washer-Flat	22	51-4060	3	Screw-Blade
4	3231-28	2	Screw-CARR	23	103-0865	3	Washer-Blade Bolt, Heavy
5	98-5980	1	Guide-Belt	24	3231-2	5	Screw-CARR
6	110-6975	1	Guide-Belt	25	322-6	1	Screw-HH
7	105-0850	1	Guide-Belt	26	323-14	1	Screw-HH
8	104-8301	35	Nut-Flange, NI	27	110-0729	1	Spindle ASM
9	32128-21	3	Nut-HF	28	3256-3	1	Washer-Flat
10	92-1624	22	Screw-HWH	29	32128-13	1	Nut-HHF
11	104-6374	1	Plate-Spring	30	110-0735-03	1	Baffle ASM
12	108-2728	1	Idler Arm ASM	31	121-1792-03	1	Baffle ASM
12:2	302-11	1	Fitting-Lube, 45 DEG	32	110-0744-01	1	Baffle-Discharge
12:3	256-90	2	Bushing-Flange	33	107-3166-01	1	Skid
14	52-2860	2	Washer	34	3231-1	3	Screw-CARR
15	93-1622	1	Pulley-Idler	35	109-6658	1	Nut-Flange, NI
16	9202414	1	Washer-Spacer	36	32128-19	1	Nut-HF
17	51-3650	1	Spring-Extension	37	108-2715	1	Belt-V
18	323-9	1	Screw-HH	38	323-4	3	Screw-HH
19	112-7091	1	Spacer				

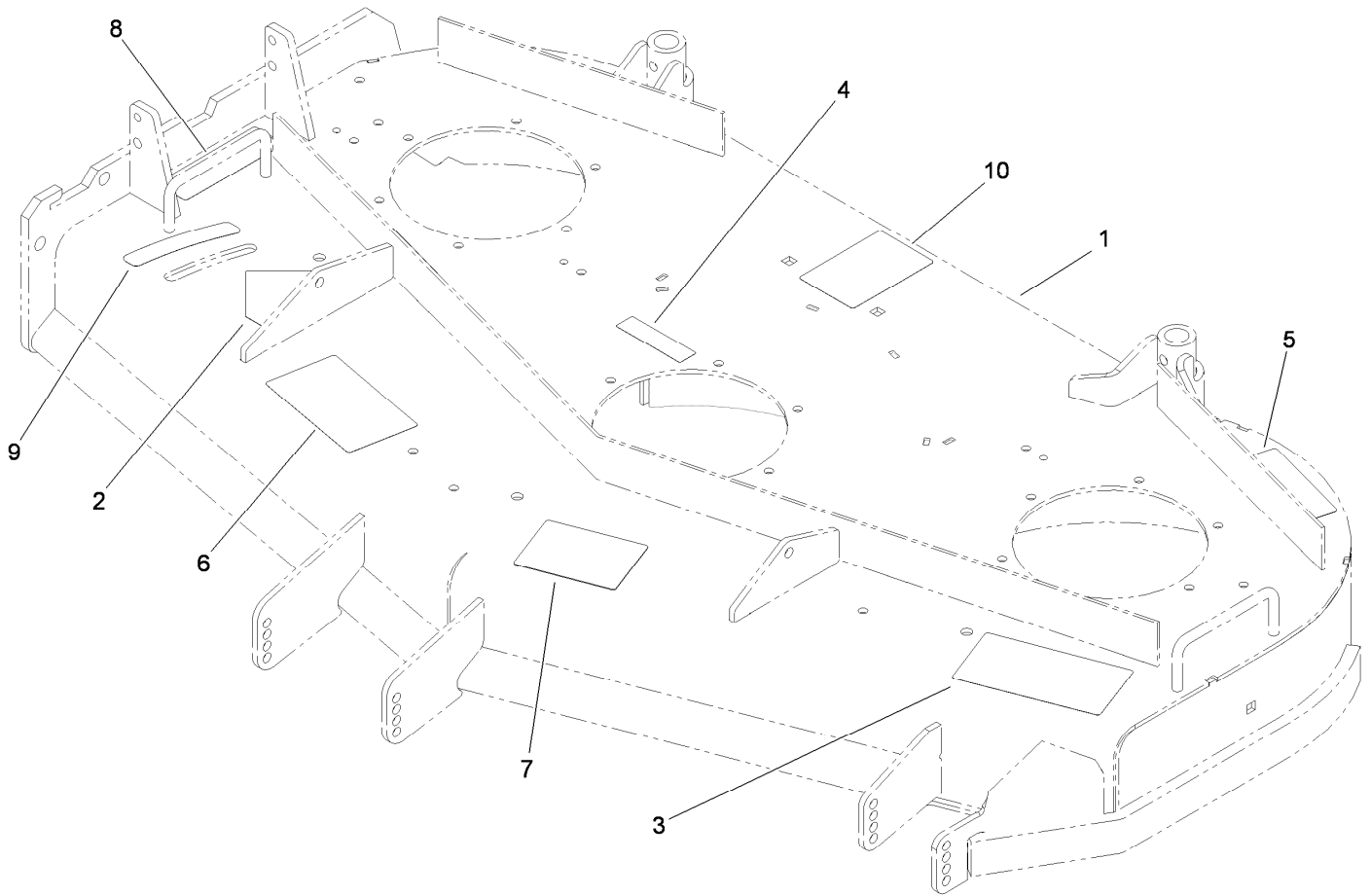

## Deck Decal Assembly No. 112-7082

<i>Ref.</i>	<i>Part Number</i>	<i>Qty.</i>	<i>Description</i>
1		1	48 Inch Deck ASM ●
2	1-403005	1	Decal-Danger
3	66-1340	1	Decal-Danger, Thrown Object
4	98-5954	3	Decal-Cover, Missing
5	68-8340	1	Decal-Torque
6	110-2068	1	Decal-Adjustment, Baffle
7	105-7798	1	Decal-Scalp, Anti
8	104-8569	1	Decal-Warning
9	110-2067	1	Decal-Setting, Baffle
10	104-8186	1	Decal-Routing, Belt

● Not serviced separately

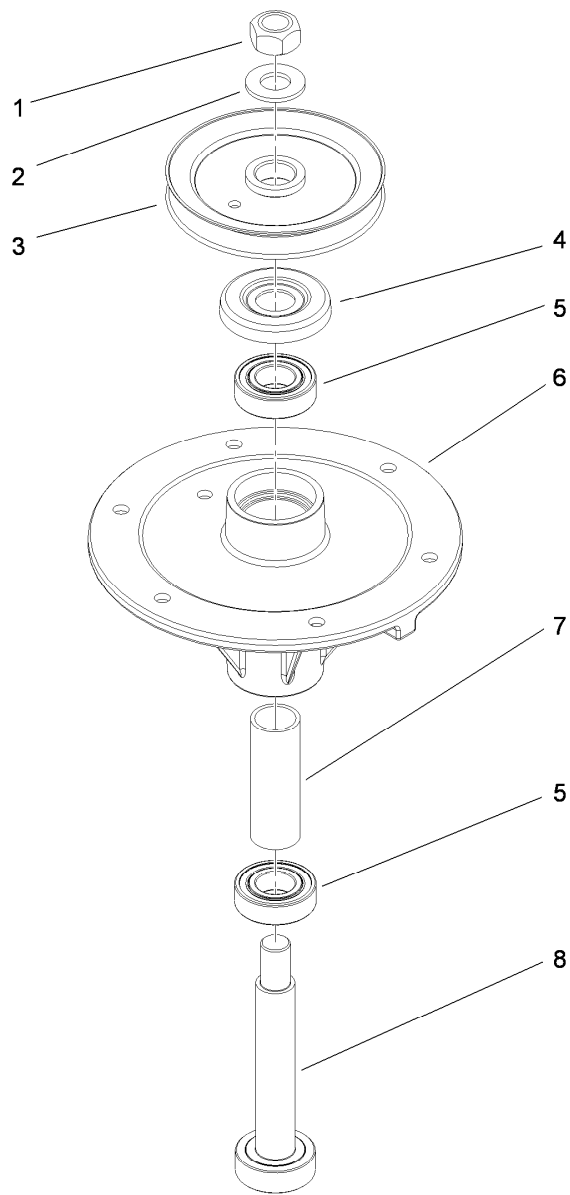

## Spindle Assembly No. 110-0728

<i>Ref.</i>	<i>Part Number</i>	<i>Qty.</i>	<i>Description</i>
1	3219-7	1	Nut-Hex
2	7-4150	1	Washer
3	104-1181	1	Pulley ASM
4	106-0873	1	Shield-Bearing
5	116-0720	2	Bearing-Ball
6	108-6696	1	Housing-Spindle
7	110-0727	1	Spacer-Bearing
8	110-0726	1	Shaft-Spindle

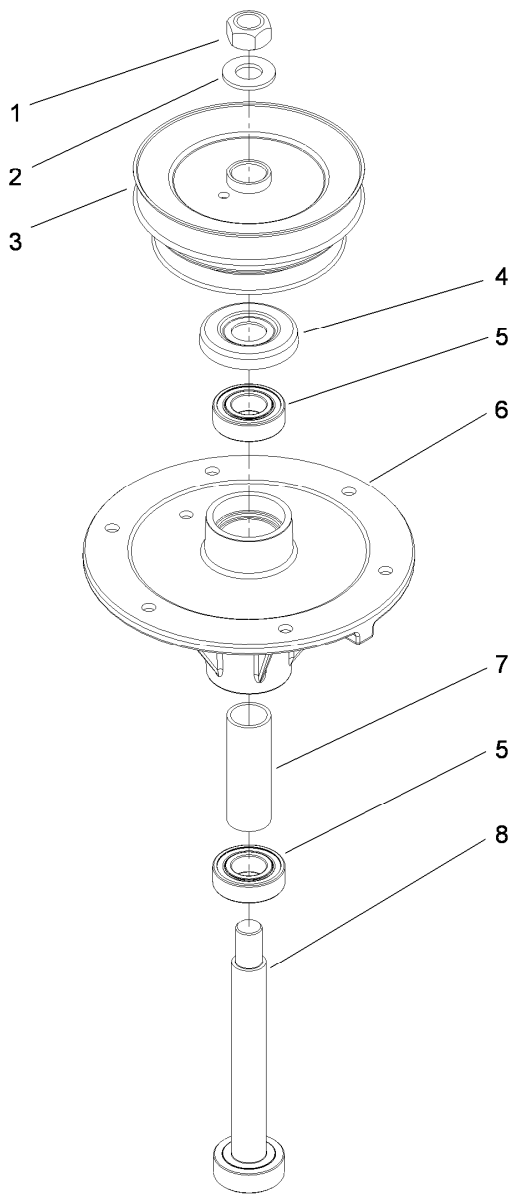

## Spindle Assembly No. 110-0729

<i>Ref.</i>	<i>Part Number</i>	<i>Qty.</i>	<i>Description</i>
1	3219-7	1	Nut-Hex
2	7-4150	1	Washer
3	108-2713	1	Pulley And Hub ASM
4	106-0873	1	Shield-Bearing
5	116-0720	2	Bearing-Ball
6	108-6696	1	Housing-Spindle
7	110-0727	1	Spacer-Bearing
8	110-0725	1	Shaft-Spindle

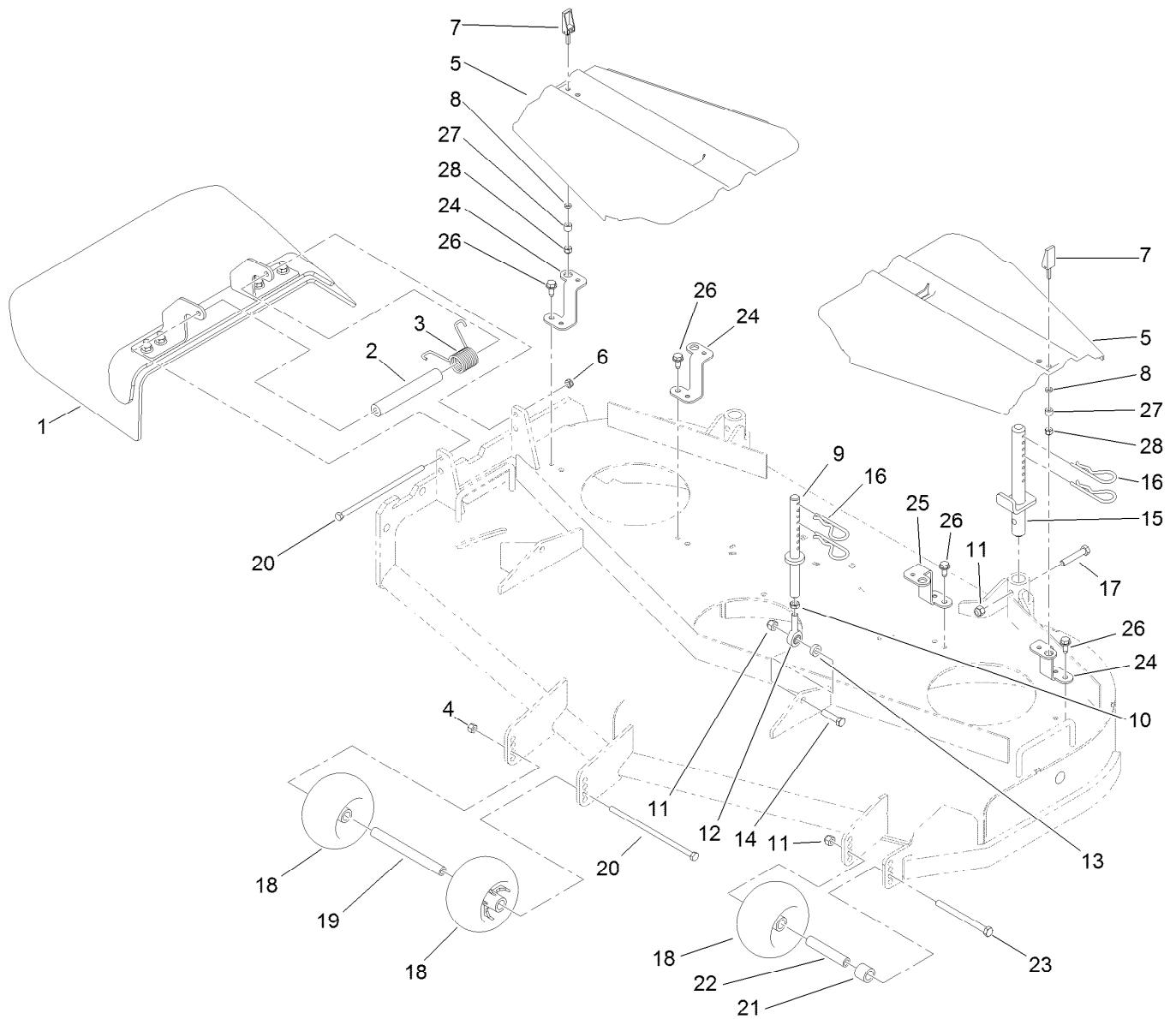

## Deck Assembly

Ref.	Part Number	Qty.	Description	Ref.	Part Number	Qty.	Description
1	110-0758	1	Deflector ASM	15	110-2086	2	Rear Pin ASM
2	105-4622	1	Spacer	16	3290-256	6	Pin-Hair
3	108-4052	1	Spring-Torsion	17	323-10	2	Screw-HH
4	3296-29	1	Nut-Lock, NI	18	1-603299	3	Roller-Scalp, Anti
5	107-8536	2	Cover-Belt	19	98-5967	1	Spacer-Wheel
6	3296-47	1	Nut-Lock, NI	20	322-50	2	Screw-HH
7	106-6777	2	Handle-Latch, Swell	21	98-7913	1	Tube-Spacer
8	99-3058	2	Washer	22	98-7912	1	Tube-Spanner
9	108-2674	2	Front Pin ASM	23	323-23	1	Screw-HH
10	3220-3	2	Nut-HJ	24	108-2698-01	3	Bracket-Cover
11	3296-39	5	Nut-Lock, NI	25	108-2699-01	1	Bracket-Cover
12	1-613204	2	Balljoint	26	32144-70	4	Screw-HWHTF
13	104-1156	2	Spacer	27	106-6778	2	Bushing-Latch, Swell
14	323-8	2	Screw-HH	28	1-804254	2	Nut-Lock, HH

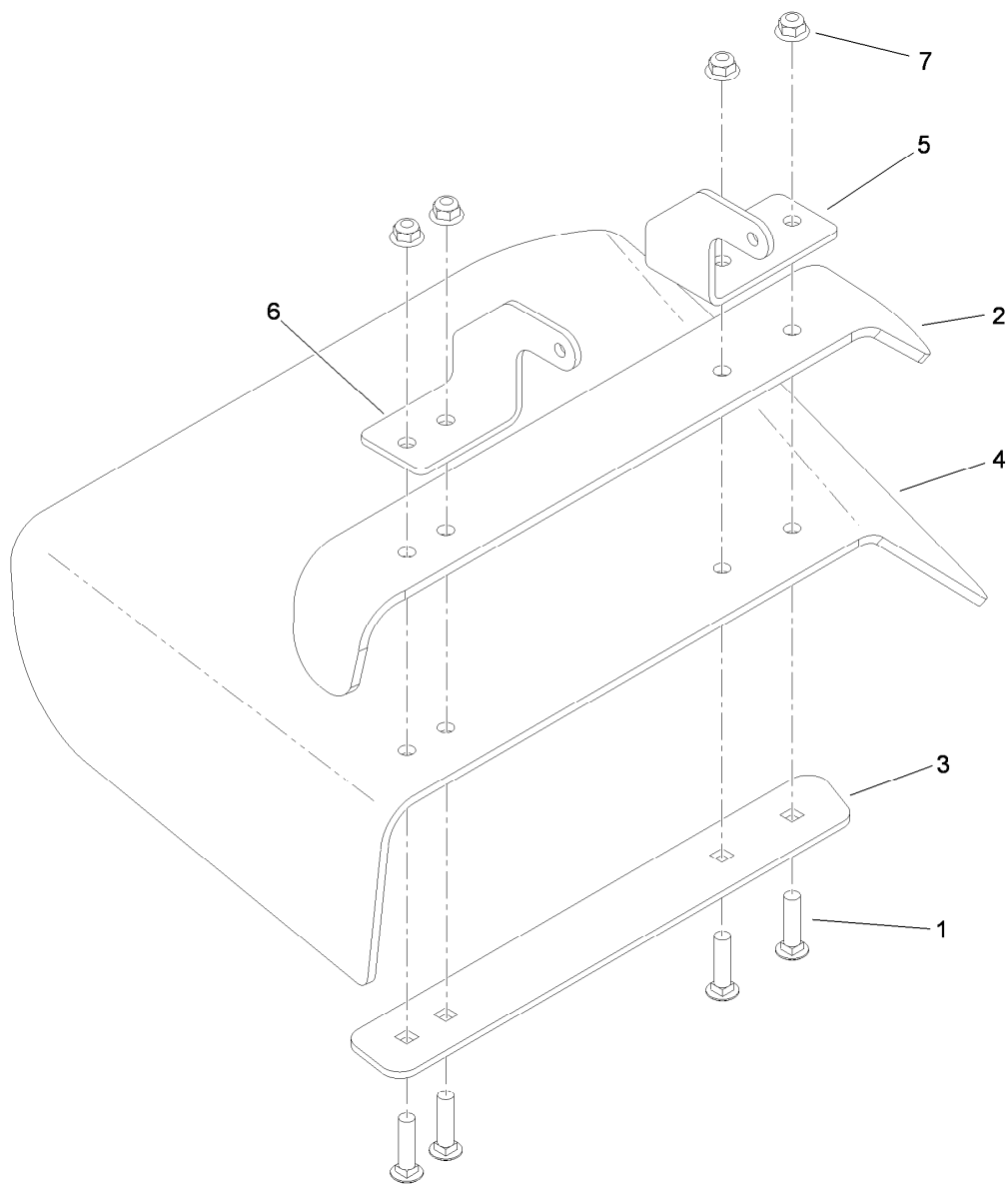

## Deflector Assembly No. 110-0758

<i>Ref.</i>	<i>Part Number</i>	<i>Qty.</i>	<i>Description</i>
1	3231-4	4	Screw-CARR
2	106-3246-01	1	Deflector
3	106-3248-03	1	Strap-Discharge
4	110-0759	1	Deflector-Rubber
5	107-4197-01	1	Bracket-Hinge, Rear
6	107-4196-01	1	Bracket-Hinge, Front
7	104-8301	4	Nut-Flange, NI

# Attachments and Accessories

## For 30488 Commercial Walk-Behind Mower Floating Deck, Split Lever, Hydro Drive with 48in TURBO FORCE Cutting Unit

<b>Product Name</b>	<b>Model/Part</b>
Blade-Low Flow, 16.5in.....	107-3193-03
Blade-Mid Flow, 16.5in .....	107-3194-03
Blade-Atomic, 16.5in .....	107-3195-03
Blade-Recycling, 16.5in.....	107-3196-03
Bagging Enhancement Kit .....	108-4091
Blade-Hi Flow, 16.5in (6 Pack).....	110-0414
Blade-Lo Flow, 16.5in (6 Pack) .....	110-0415
Blade-Recycler, 16.5in (6 Pack).....	110-0416
Blade-Atomic, 16.5in (6 Pack) .....	110-0417
Blade-Mid Flow, 16.5in (6 Pack) .....	110-0418
48in Recycler Kit.....	110-2060
Weight-Cast.....	112-7059-01
Weight Kit .....	112-9971
Trim Side Anti-Scalp Roller Kit.....	115-1015
Discharge Side Anti-Scalp Roller Kit.....	115-1016
Operator Controlled Discharge Chute Kit.....	115-4195
Soft Bag (3 Bushel).....	30104
Tru Trak Sulky.....	30110

**Notes:**

**Notes:**

**Notes:**



**Count on it.**