

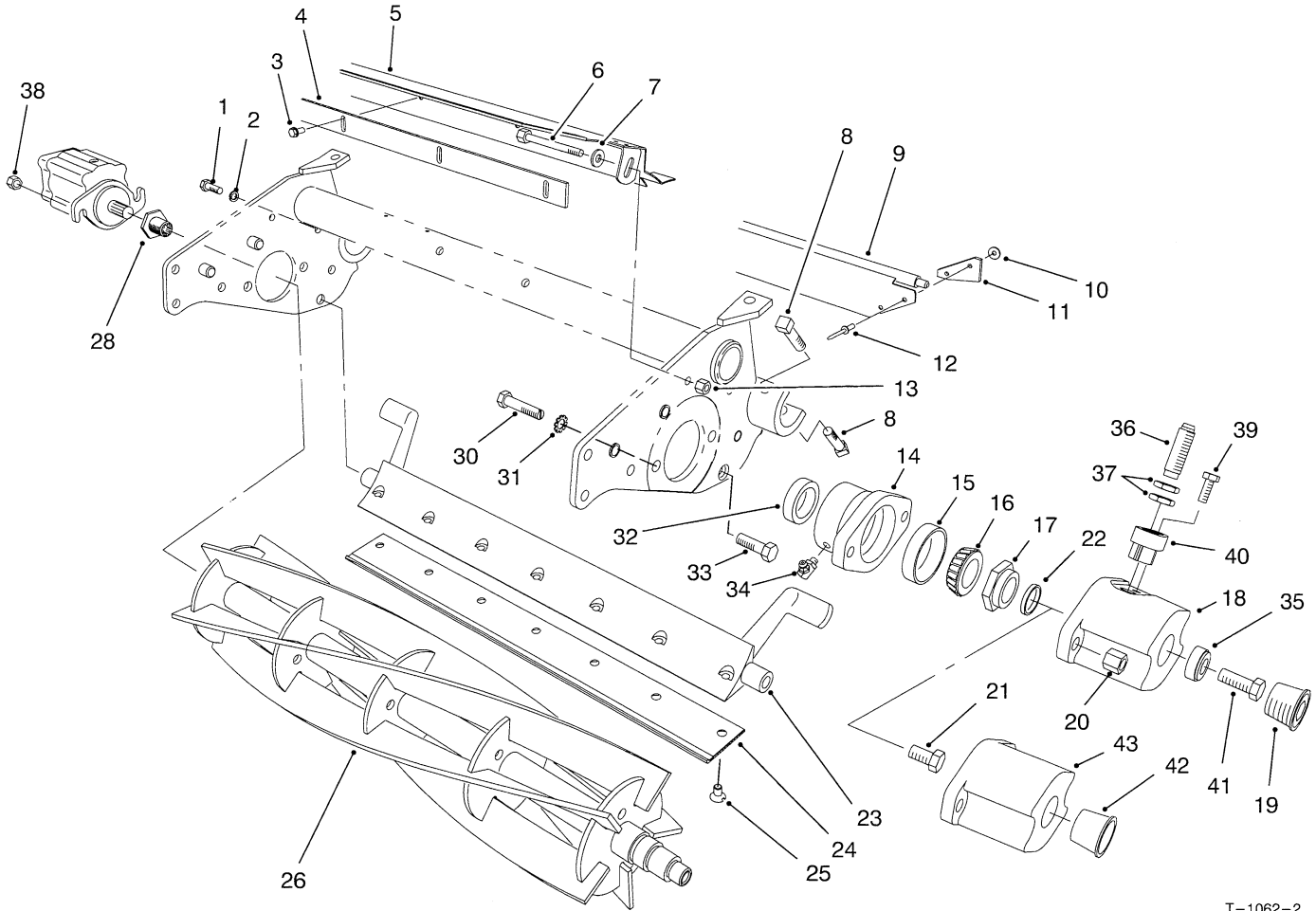

MODEL NO. 03505-60001 & UP
MODEL NO. 03508-60001 & UP

**PARTS
CATALOG**

**5 BLADE & 8 BLADE CUTTING UNITS
For Reelmaster® 5100D/5300D Traction Units**



T-1062-2

REEL ASSEMBLY

Ref. No.	Part No.	Description	No. Used
1	322-5	Screw - Cap Hex. Hd.	1
2	3253-4	Washer - Lock	1
3	32144-73	Screw - Self Tapping	5
4	36-7260	Bar - Cutoff	1
5	75-1840	Shield - Grass	1
6	321-23	Screw - Cap Hex. Hd.	2
7	3256-1	Washer - Flat	2
8	3243-13	Screw - Sq. Hd. Set	4
9	75-1560	Deflector - Rear	1
10	3256-49	Washer - Flat	4
11	75-1720	Flap - Rear Shield	2
12	3290-409	Rivet - Pop	4
13	3296-42	Nut - Lock	2
14	10-5120	Housing - Bearing	2
15	254-72	Cup - Bearing	2
16	254-94	Cone - Bearing	2

Ref. No.	Part No.	Description	No. Used
17	3296-60	Nut - Reel	1
†18	93-8732	Cap - End	1
†19	93-8717	Plug - Hole	1
20	3296-39	Nut - Lock L.H.	2
21	323-2	Screw - Cap Hex. Hd.	1
22	253-61	Seal - Oil	1
23	10-4930	Bedbar	1
24	63-8610	Bedknife	1
25	57-4910	Screw - Bedknife	7
26	14-0659	Reel - 5 Blade	1
*	14-0649	Reel - 8 Blade	1
28	93-1394	Nut - Spline	1
30	57-3210	Screw - Special	4
31	3255-9	Washer - E.T.L.W.	4
32	253-96	Seal - Oil	2
33	217-74	Bolt - Bedbar	2

*Not Illustrated

†Cutting Unit with Speed Sensor

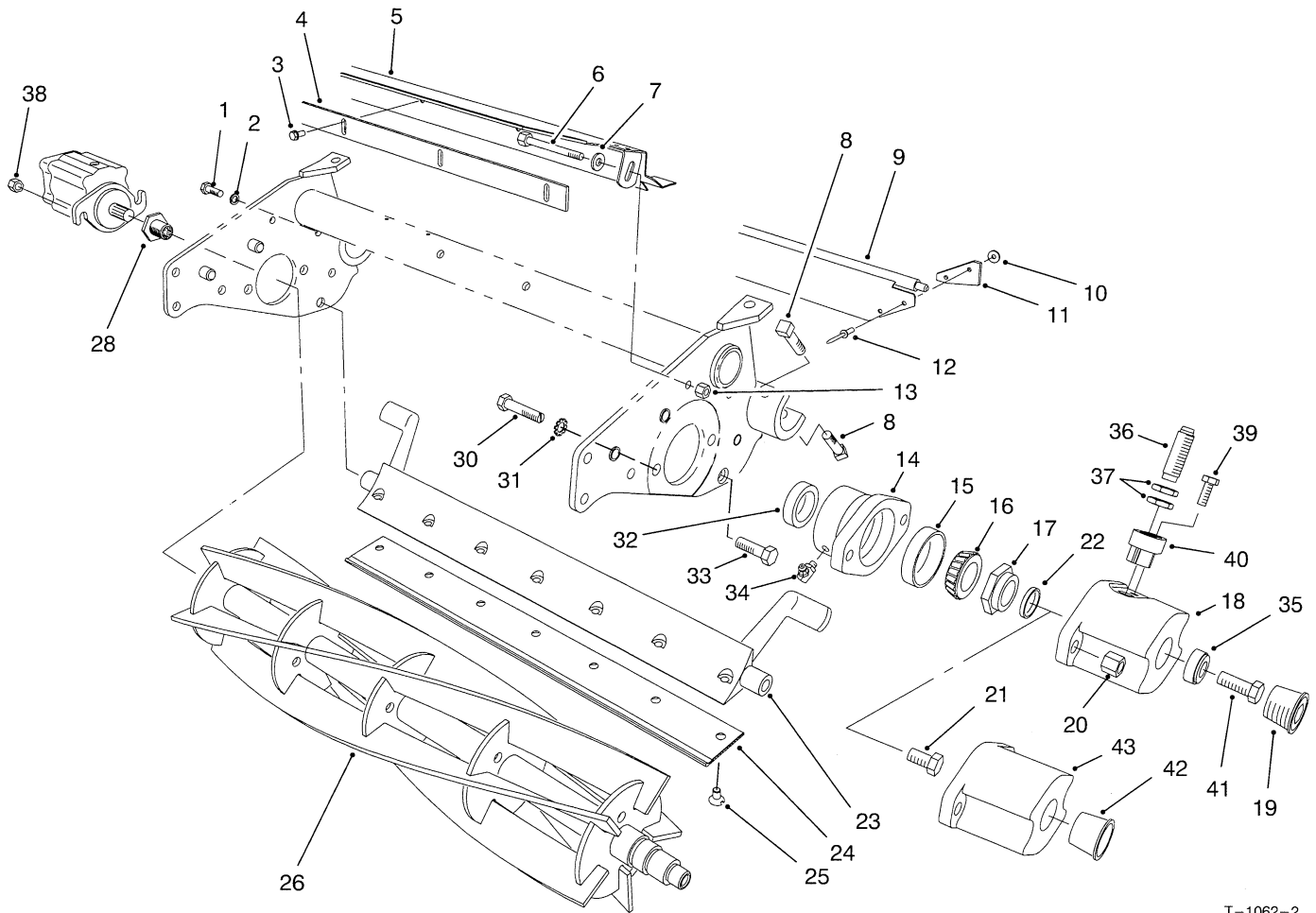

T-1062-2

REEL ASSEMBLY (Continued)

Ref. No.	Part No.	Description	No. Used
34	302-60	Fitting - Grease L.H. 90°	1
*	302-11	Fitting - Grease R.H. 45°	1
†35	85-4380	Magnet	2
†36	85-4390	Sensor Assembly (Incl. Ref. #37)	2
†37		Nut - Jam	4
38	32128-36	Nut - Flange Lock R.H.	2

Ref. No.	Part No.	Description	No. Used
†39	3235-20	Screw - Cap Hex. Hd.	1
†40	92-4079	Housing - Sensor	1
†41	30-2120	Screw - Cap Hex. Hd.	1
42	12-0460	Plug - Hole	1
43	10-5080	Cap - End	1

*Not Illustrated
 †Cutting Unit with Speed Sensor

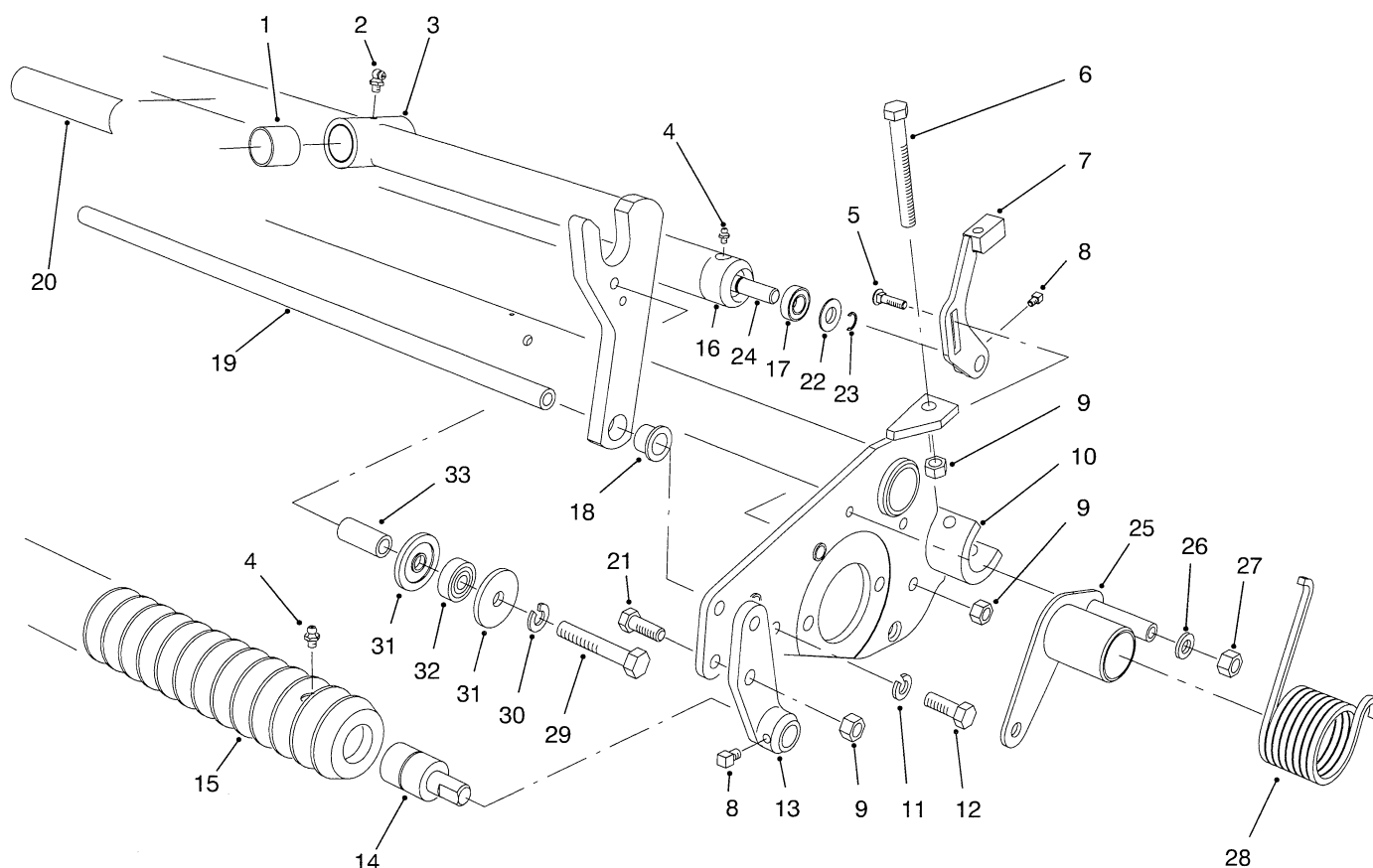

T-1439-1

ROLLER ASSEMBLY

Ref. No.	Part No.	Description	No. Used	Ref. No.	Part No.	Description	No. Used
1	67-1750	Bushing - Sleeve	2	20	67-7960	Decal - Warning (English)	1
2	302-60	Fitting - Grease	1	*	84-4220	Decal - Warning (Japanese)	1
3	75-1600	Carrier Frame Assembly (Incl. Ref. #1, 2 & 18)	1	*	84-4210	Decal - Warning (Danish)	1
4	302-5	Fitting - Grease	4	*	84-4200	Decal - Warning (Dutch)	1
5	3231-2	Bolt - Carriage	2	*	84-4190	Decal - Warning (Italian)	1
6	323-49	Screw - Cap Hex. Hd.	2	*	84-4180	Decal - Warning (Spanish)	1
7	75-1620	Bracket - HOC Rear L.H.	1	*	84-4170	Decal - Warning (German)	1
*	75-1610	Bracket - HOC Rear R.H.	1	*	84-4160	Decal - Warning (French)	1
8	3242-2	Screw - Sq. Hd. Set	4	*	84-4150	Decal - Warning (Swedish)	1
9	3296-39	Nut - Lock	8	21	323-7	Screw - Cap Hex. Hd.	4
10	75-6660	Cutting Unit Frame Assy. (Incl. Ref. #11, 12 & 19)	1	22	85-7190	Washer - Shield	2
11	3253-21	Washer - Lock	2	23	32151-12	Ring - Retaining	2
12	323-6	Screw - Cap Hex. Hd.	2	24	85-7180	Shaft - Roller	1
13	75-1980	Bracket - HOC Front L.H.	1	25	83-4710	Plate - Spring, LH	1
*	75-1960	Bracket - HOC Front R.H.	1	*	83-4700	Plate - Spring, RH	1
14	75-1290	Bearing Assembly	2	26	3256-78	Washer - Plain	2
15	75-1520	Wiehle Roller Assembly (Incl. Ref. #4 & 14)	1	27	3296-42	Nut - Lock	2
16	85-7220	Rear Roller Assembly (Incl. Ref. #4, 17 & 22-24)	1	28	83-4730	Spring - Torsion, LH	1
17	85-9970	Bearing Assembly	2	*	83-4720	Spring - Torsion, RH	1
18	75-2160	Bearing - Flange	2	29	322-9	Screw - Cap Hex. Hd.	2
19	75-1710	Support - Cutting Unit	1	30	3253-4	Washer - Spring Lock	2
				31	82-6890	Washer - Special	4
				32	251-259	Bearing - Ball	2
				33	82-6840	Spacer	2

*Not Illustrated

