



Count on it.

Parts Catalog

Commercial Walk-Behind Mower
Fixed Deck, T-Bar, Gear Drive with 32in
Cutting Unit

Model No. 30672—Serial No. 312000001 and Up

Ordering Replacement Parts

To order replacement parts, please supply the part number, the quantity, and the description of each part desired.

Understanding Reference Numbers

Each identified part in an illustration has a reference number. The reference number for a part also appears in the parts list, along with other information about the part.

This catalog uses two special reference number formats, one to indicate parts in a service assembly and another to indicate the quantity of a given part in an illustration.

Service Assembly Reference Numbers

Parts in service assemblies have reference numbers in the form a:b. The a represents the reference number of the entire service assembly and the b represents a sequential number unique to each part within the service assembly.

For example, a wheel assembly might be identified by reference number 6, the tire by 6:1, the valve by 6:2, and the wheel by 6:3. When you order the assembly identified by reference number 6, you receive all parts identified by reference numbers 6:1, 6:2, and 6:3. However, you may also order any part individually. Reference numbers of this type appear in illustration and in parts lists.

Reference Numbers Indicating Quantity

In an illustration, if a reference number indicates more than one part, the reference number has the form nX y. The n represents the quantity of the part, the X is the multiplication symbol, and the y represents the reference number.

For example, in an illustration, the reference number 2X 37 means that two of the parts identified by reference number 37 are indicated.

List of Abbreviations

AR: as required

ASM: assembly

BBC: blade brake control

BHTF: button head thread forming

CARR: carriage

CCW: counter clockwise

CW: clockwise

DEG: degrees

DPA: Dual Point Adjustment

ECM: electronic control module

EXT: external

FH: flat head

GA: gauge

HD: heavy-duty

HF: hex flange

HH: hex head

HHF: hex head flange

HHFTF: hex head flange thread forming

HJ: hex jam

HLH: hex lag head

HOC: height-of-cut

HSBH: hex socket button head

HSFH: hex socket flat head

HSH: hex socket head

HWH: hex washer head

HWHTF: hex washer head thread forming

HYD: hydraulic

LH: left hand

LP: Liquid Propane

NI: nylon insert

NPTF: national pipe thread fine

PFH: phillips flat head

PPH: phillips pan head

PPHTF: phillips pan head thread forming

PRH: phillips round head

PTH: phillips truss head

PTO: power-take-off

RH: right hand

ROPS: roll-over protection system

RRB: rear roller brush

SFH: slotted fillister head

SHH: slotted hex head

SHWH: slotted hex washer head

SPH: slotted pan head

SQH: square head

SRH: slotted round head

STD: standard

TAP: self tapping

TTH: torx truss head

Contents

Engine and Exhaust Assembly.....	4
Fuel System Assembly	6
Frame and Transmission Assembly	7
Drive Wheel and Brake Assembly	8
Handle and Control Assembly	10
Wire Harness Assembly	11
Deck and Shield Assembly	12
Deck Decal Assembly No. 110-6901.....	13
Deflector Assembly No. 119-6529.....	14
Idler Arm and Caster Wheel Assembly.....	15
Spindle and Blade Assembly	17
Cutter Housing Assembly No. 107-4065	18
Attachments and Accessories	19

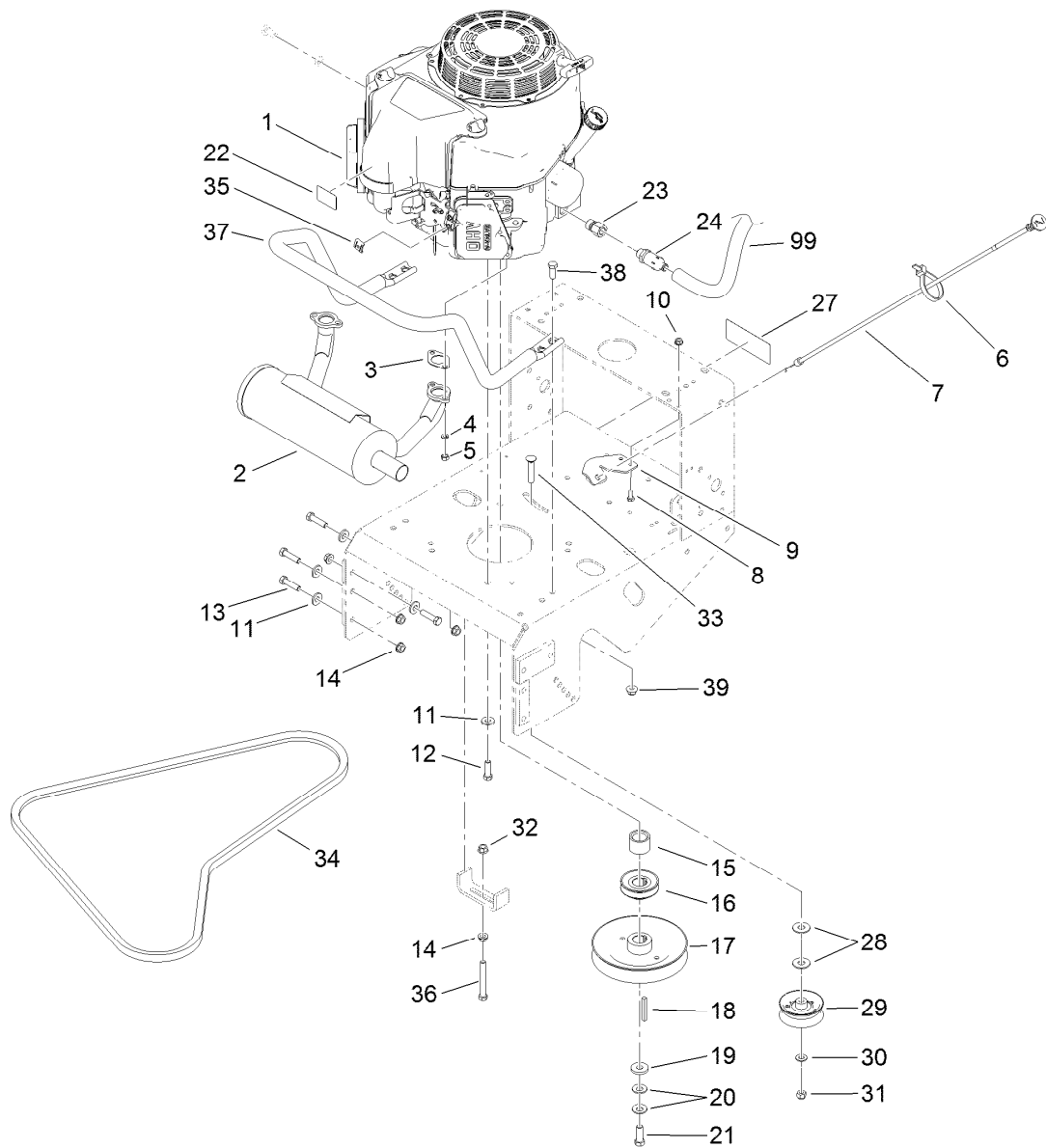

Engine and Exhaust Assembly

Ref.	Part Number	Qty.	Description	Ref.	Part Number	Qty.	Description
1		1	Engine-Kawasaki, Fs481V-As06 ●■	18	103-4177	1	Key
2	116-3734	1	Muffler-Horizontal, Offset	19	1-373034	1	Washer
3	1-653313	2	Gasket-Exhaust	20	1-603610	2	Washer-Spring
4	114-3550	4	Washer-Lock, Spring	21	116-3702	1	Screw-HH
5	114-3549	4	Nut	22	103-2076	1	Decal-Caution
6	1-303287	1	Tie-Cable	23	103-1966	1	Adapter
7	103-1796	1	Cable-Choke	24	92-6877	1	Valve-Drain, Oil
8	321-3	2	Screw-HH	27	98-0776	1	Decal-Caution
9	103-1797-01	1	Bracket-Cable, Choke	28	3256-5	2	Washer-Flat
10	32128-33	2	Nut-HF	29	1-323285	1	Pulley-Idler, Flat
11	98-5975	12	Washer-Belleville	30	3256-24	1	Washer-Flat
12	323-7	4	Screw-HH	31	3296-39	1	Nut-Lock, NI
13	323-8	8	Screw-HH	32	32128-21	1	Nut-HF
14	3290-357	9	Nut-HHF, Whiz	33	3231-6	1	Screw-CARR
15	1-633453	1	Spacer-Clutch	34	1-323745	1	Belt-V
16	103-1666	1	Sheave-Transmission	35	81-1690	1	Clamp-Cable
17	103-1667	1	Sheave	36	323-14	1	Screw-HH
				37	116-6278-03	1	Guard-Muffler

● Not serviced separately

■ Obtain parts from www.kawpowerpc.com

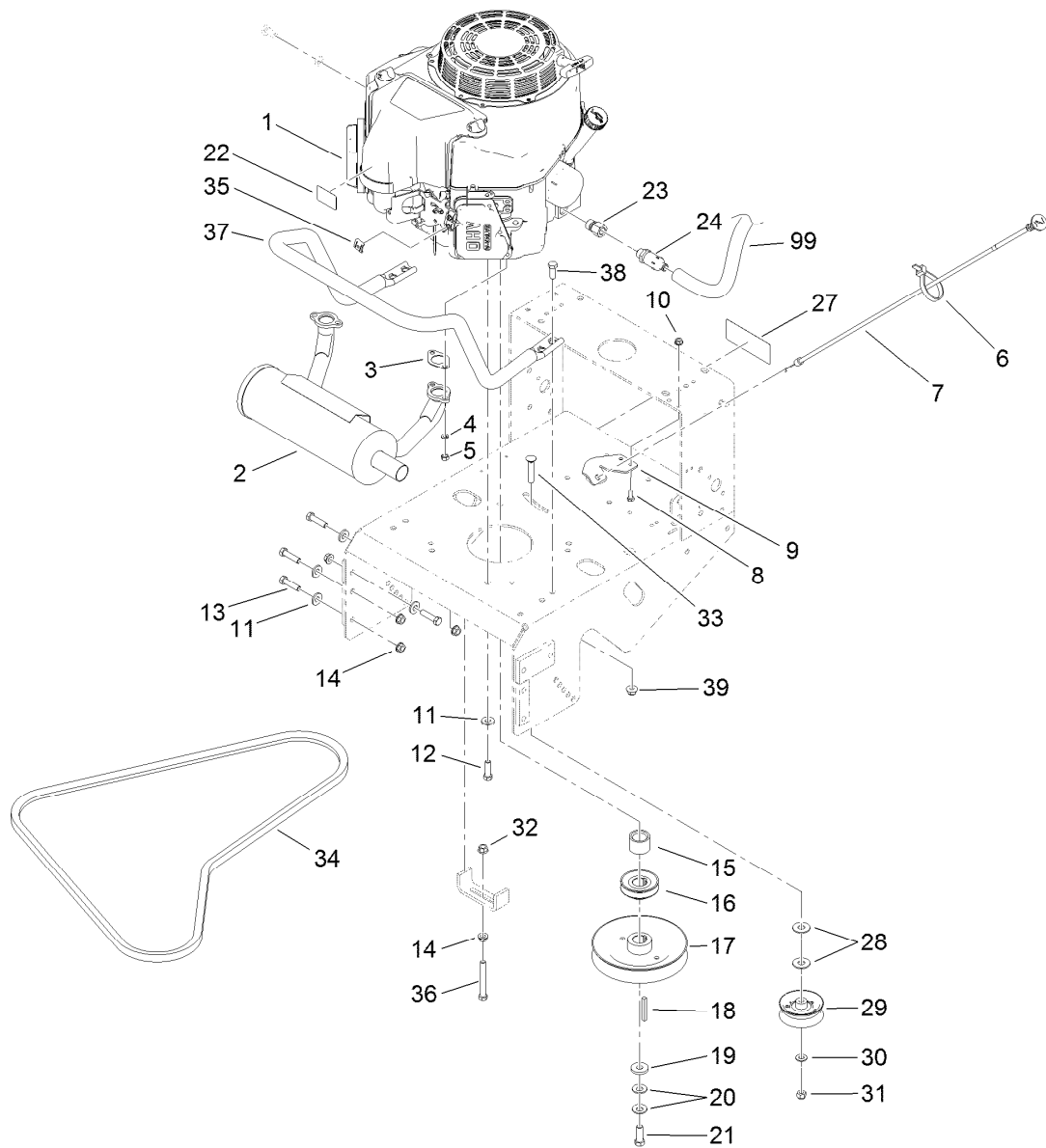

Engine and Exhaust Assembly (continued)

Ref.	Part Number	Qty.	Description
38	323-6	4	Screw-HH

Ref.	Part Number	Qty.	Description
39	104-8301	4	Nut-Flange, NI
99	103-1964	1	Hose-Drain, Oil

● Not serviced separately

■ Obtain parts from www.kawpowerpc.com

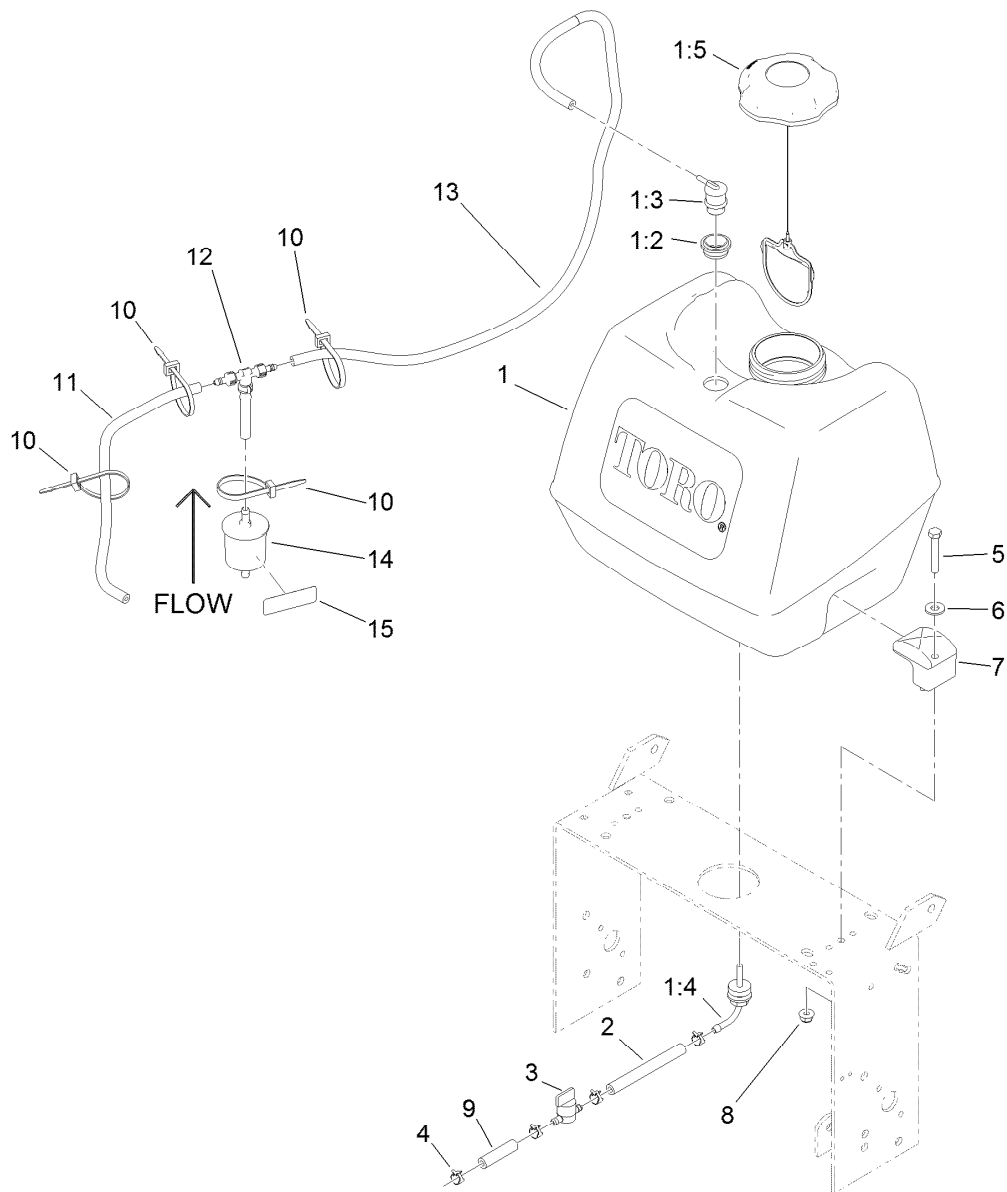

Fuel System Assembly

Ref.	Part Number	Qty.	Description	Ref.	Part Number	Qty.	Description
1	119-7899	1	Fuel Tank ASM	7	107-4543	2	Clamp
1:2	114-0284	1	Grommet	8	104-8300	2	Nut-Flange, NI
1:3	114-0285	1	Valve-Rollover	9	99-9415	1	Hose-Fuel
1:4	103-2605	1	Fitting-Fuel, Bulkhead	10	3290-378	4	Tie-Cable
1:5	120-5461	1	Cap-Fuel, Ratcheting	11	115-7872	1	Hose-Fuel
2	109-0650	1	Hose-Fuel	12	116-5464	1	Tee And Check ASM
3	1-603770	1	Valve-Fuel	13	116-4346	1	Hose-Emissions
4	2412-98	4	Clamp-Hose	14	120-2235	1	Filter-Air
5	322-10	2	Screw-HH	15	116-4769	1	Decal-Filter, Emissions
6	3256-3	2	Washer-Flat				

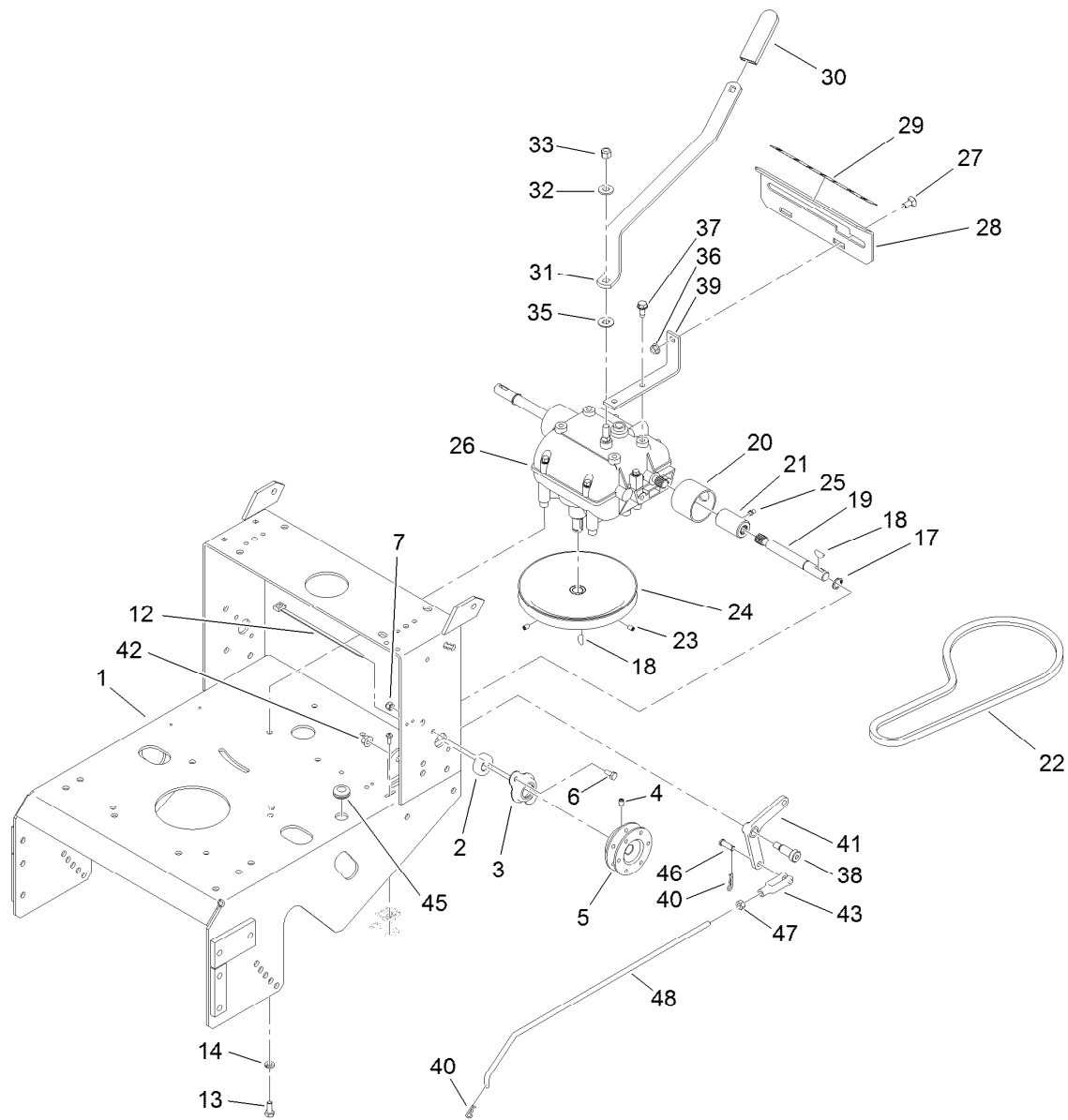

Frame and Transmission Assembly

Ref.	Part Number	Qty.	Description	Ref.	Part Number	Qty.	Description
1	116-6084-01	1	Gear Frame ASM	27	3230-1	2	Bolt-CARR
2	1-323252	2	Bearing-Shaft	28	1-323387-03	1	Plate-Shift
3	1-323254	2	Flange-Output	29	98-3256	1	Decal-Speed, Ground
4	1-803310	2	Screw-Set	30	1-303020	1	Grip-Lever
5	103-6512	2	Sheave-Transmission	31	98-3274-03	1	Lever-Shift
6	321-3	4	Screw-HH	32	98-5975	1	Washer-Belleville
7	3296-42	4	Nut-Lock, NI	33	3296-6	1	Nut-Lock
12	1-303287	1	Tie-Cable	35	1-323379	1	Washer
13	322-3	4	Screw-HH	36	32128-20	2	Nut-HF
14	1-805005	4	Washer-Lock	37	9264964	4	Screw-HWH, Thread Cut
17	32151-62	2	Ring-Retaining	38	1-603403	1	Bolt-Shoulder
18	3257-5	3	Key-Woodruff	39	1-323389-03	2	Bracket-Plate, Shift
19	1-323502	2	Shaft-Transmission	40	1-806003	2	Pin-Cotter, Hair
20	51-4220	2	Guard-Coupler	41	1-303186	1	Bellcrank
21	1-323680	2	Coupler	42	32128-21	1	Nut-HF
22	1-323630	1	V-Belt	43	1-303105	1	Yoke-Adjustable
23	3245-41	2	Screw-HSH	45	1-543296	1	Grommet
24	1-323278	1	Sheave-Transmission	46	1-808280	1	Pin-Clevis
25	302-19	2	Fitting-Grease	47	3219-2	1	Nut-Hex
26	1-323500	1	Transmission	48	1-323303	1	Linkage-Arm

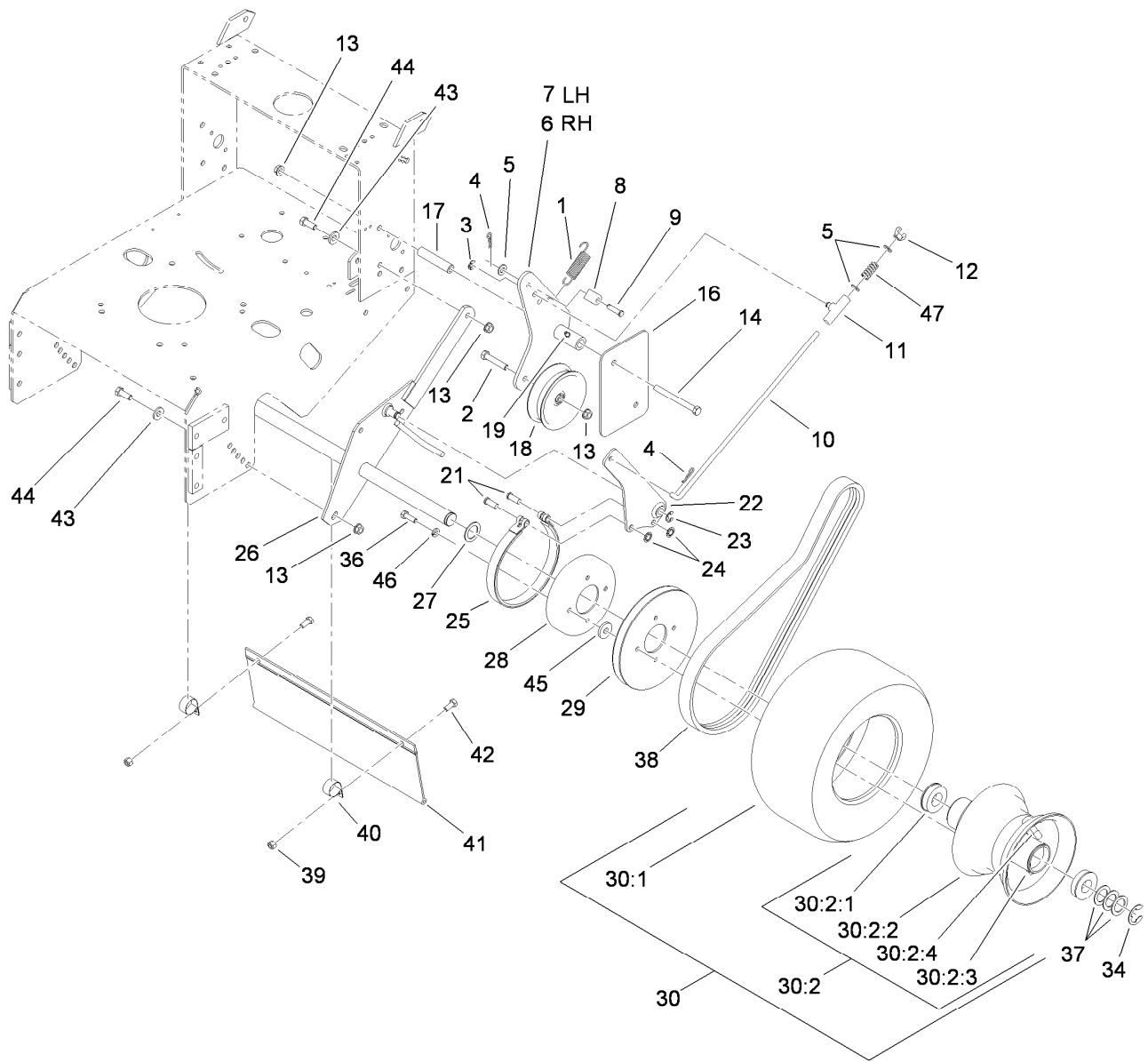

Drive Wheel and Brake Assembly

Ref.	Part Number	Qty.	Description	Ref.	Part Number	Qty.	Description
1	98-3273	2	Spring-Extension	21	1-323307	4	Pin-Clevis
2	323-10	2	Screw-HH	22	1-322209-03	2	Brake Arm ASM
3	32151-47	2	Ring-Retaining	23	32120-47	2	Ring-Retaining, External
4	1-806003	4	Pin-Cotter, Hair	24	1-803051	4	Nut-Push
5	3256-23	4	Washer-Flat	25	1-323595	2	Band-Brake
6	110-4925-03	1	RH Idler Arm ASM	26	1-322232-03	1	Axle ASM
7	110-4926-03	1	LH Idler Arm ASM	27	1-543436	2	Washer-Spacer
8	74-0521	2	Fitting-Rod	28	1-323261	2	Drum-Brake
9	283-6	2	Pin-Clevis	29	1-323349	2	Sheave-Wheel, Drive
10	1-323296	2	Rod-Brake	30	1-323346	2	Wheel And Tire ASM
11	110-5866	2	Swivel-Brake	30:1	1-323361	1	Tire
12	1-513959	2	Wingnut-Nylock	30:2	1-323360	1	Wheel And Hub ASM
13	3290-357	10	Nut-HHF, Whiz	30:2:1	1-323329	2	Bearing-Flanged
14	323-16	4	Screw-HH	30:2:2		1	Rim ASM ●
16	98-5131-01	2	Shield-Wheel, Drive	30:2:3		1	Fitting-Grease ●
17	1-323694	4	Spacer-Shield	30:2:4		1	Valve Stem And Cap ●
18	1-323634	2	Idler-Drive, Wheel	34	1-808519	2	Ring-Snap
19	302-19	2	Fitting-Grease	36	322-5	8	Screw-HH

● Not serviced separately

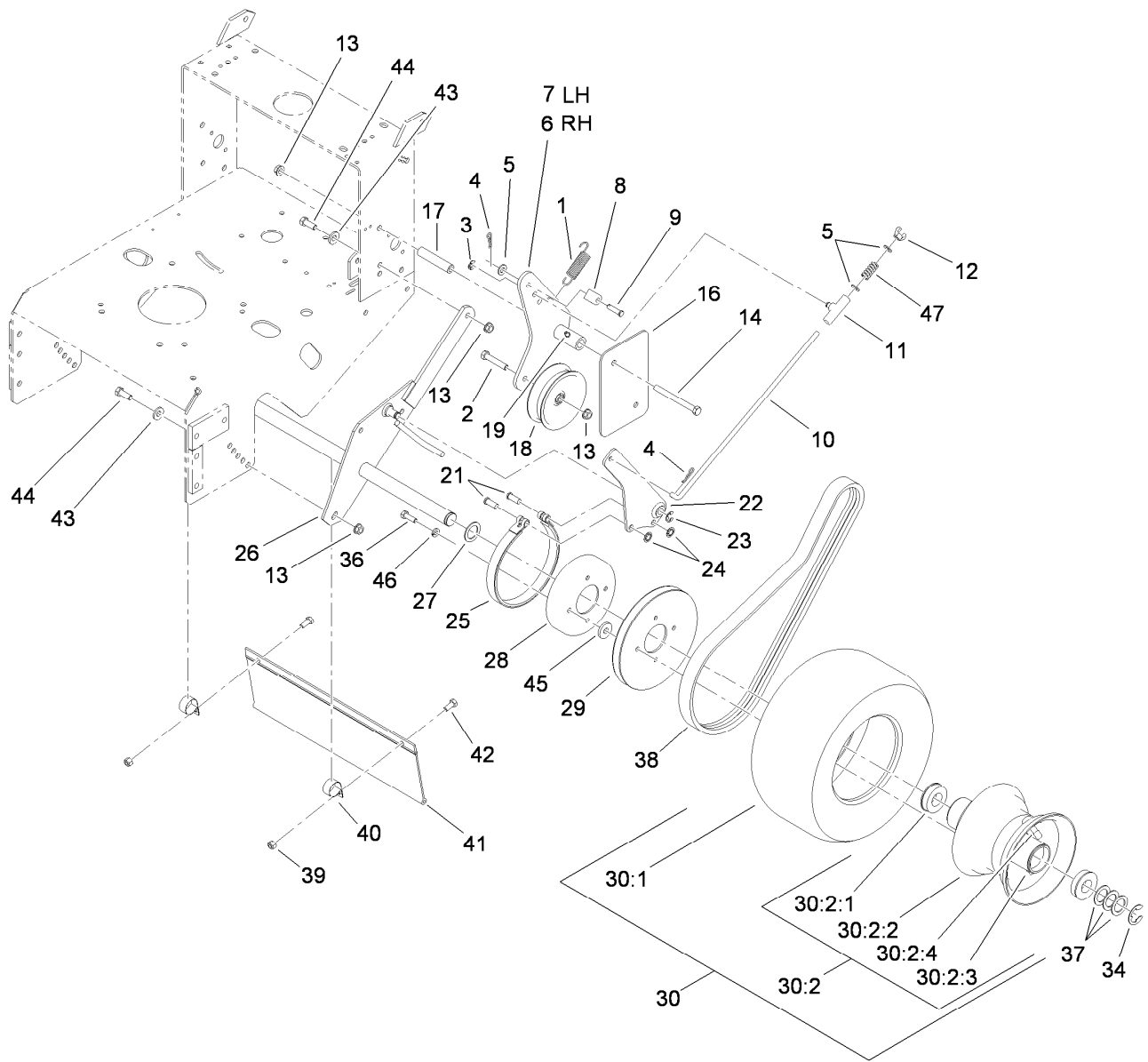

Drive Wheel and Brake Assembly (continued)

Ref.	Part Number	Qty.	Description	Ref.	Part Number	Qty.	Description
37	1-523157	6	Washer-Spacer	43	98-5975	4	Washer-Belleville
38	1-323744	2	Belt-Drive, Wheel	44	323-6	4	Screw-HH
39	3296-29	2	Nut-Lock, NI	45	1-373034	8	Washer
40	2412-104	2	Clamp-R	46	1-805005	8	Washer-Lock
41	98-3259	1	Shield-Trailing	47	1-323245	2	Spring-Compression
42	322-3	2	Screw-HH				

● Not serviced separately

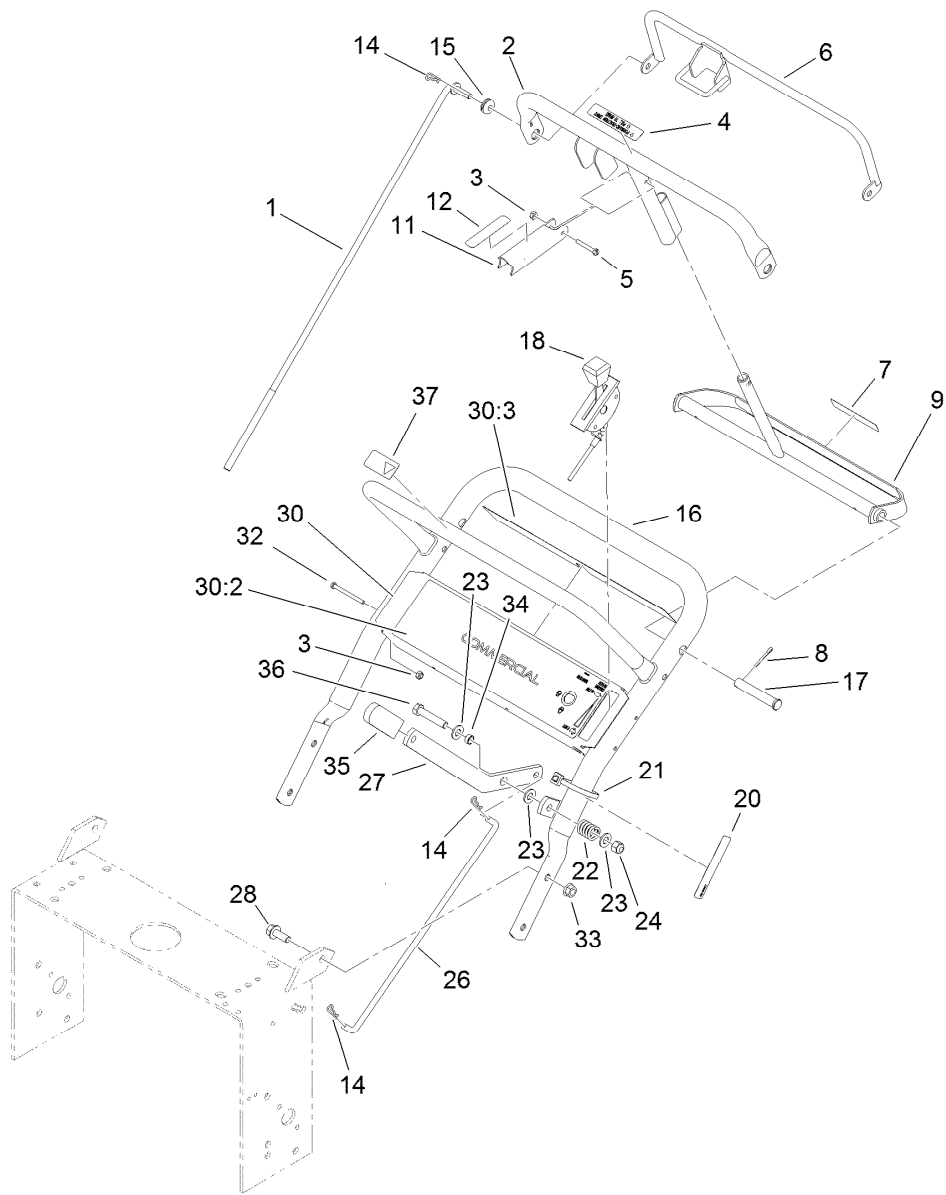

Handle and Control Assembly

Ref.	Part Number	Qty.	Description	Ref.	Part Number	Qty.	Description
1	98-3282	2	Rod-Control	21	1-303335	2	Tie-Plastic
2	95-5522-03	1	Control Bar ASM	22	1-303160	1	Spring-Compression
3	3296-2	5	Nut-Lock, NI	23	3256-24	3	Washer-Flat
4	82-2290	1	Decal	24	3296-39	1	Nut-Lock, NI
5	32105-1	1	Screw-SHH	26	98-3279	1	Linkage-Drive, Blade
6	82-7680-03	1	Bail ASM	27	98-3287-03	1	Lever-Engagement, Blade
7	82-2280	1	Decal	28	3234-11	4	Screw-HHF
8	3272-11	2	Pin-Cotter	30	110-6905	1	Control Panel ASM
9	99-8501-03	1	Control-Pivot	30:2	110-6916	1	Decal-Panel, Control
11	98-3261-03	1	Lever-Brake, Parking	30:3	105-0884	1	Decal-Danger
12	98-3266	1	Decal	32	32105-14	4	Screw-SHH
14	1-806003	3	Pin-Cotter, Hair	33	32128-21	4	Nut-HF
15	237-141	2	Grommet-Rubber	34	99-8509	1	Spacer
16	98-3267-03	1	Upper Handle ASM	35	1-303020	1	Grip-Lever
17	283-55	2	Pin-Clevis	36	323-10	1	Screw-HH
18	119-6539	1	Cable-Throttle	37	98-4387	1	Decal-Protection, Ear
20	95-5537	1	Decal-Engage, Deck				

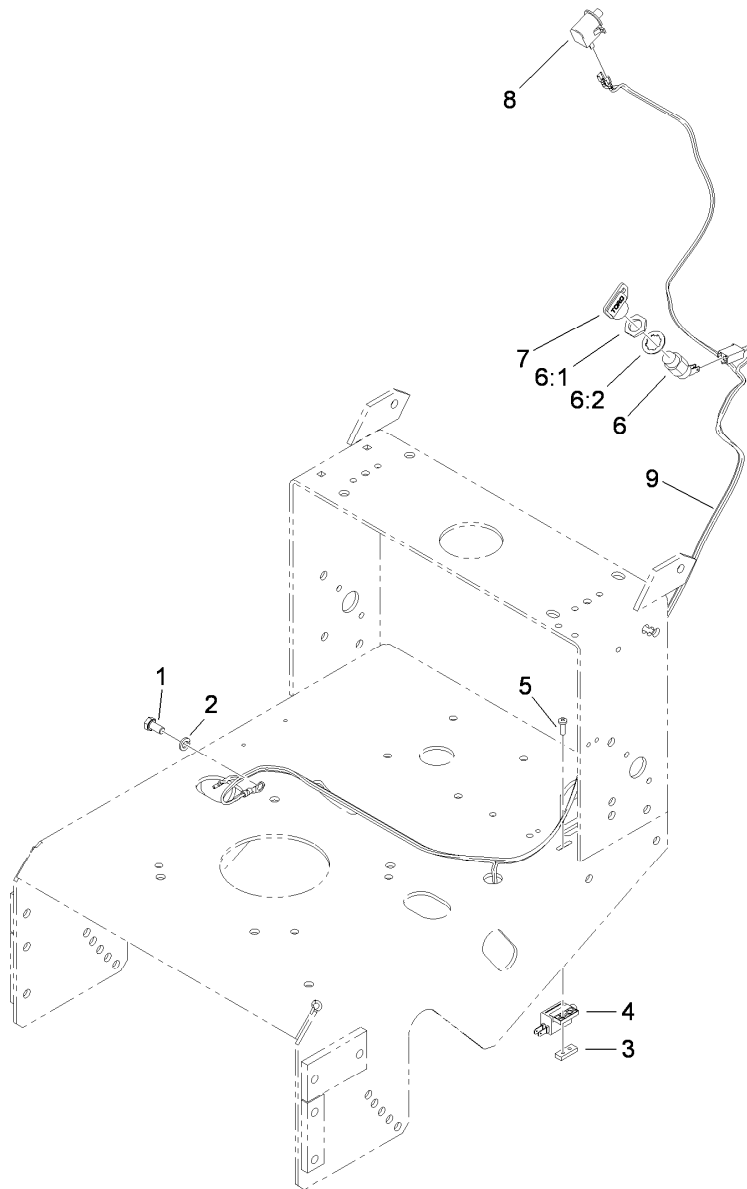

Wire Harness Assembly

<i>Ref.</i>	<i>Part Number</i>	<i>Qty.</i>	<i>Description</i>
1	33114-016	1	Screw-HH
2	3253-4	1	Washer-Lock
3	1-633181	1	Plate-Tapped
4	1-513152	1	Switch-Closed, Normally
5	3290-500	2	Screw-PPH
6	29-5560	1	Switch-On / Off
6:1	218-461	1	Nut-HH
6:2	3254-5	1	Washer-Tooth, Internal
7	63-8360	1	Key-Ignition
8	740275	1	Switch-Seat
9	119-6535	1	Harness-Wire

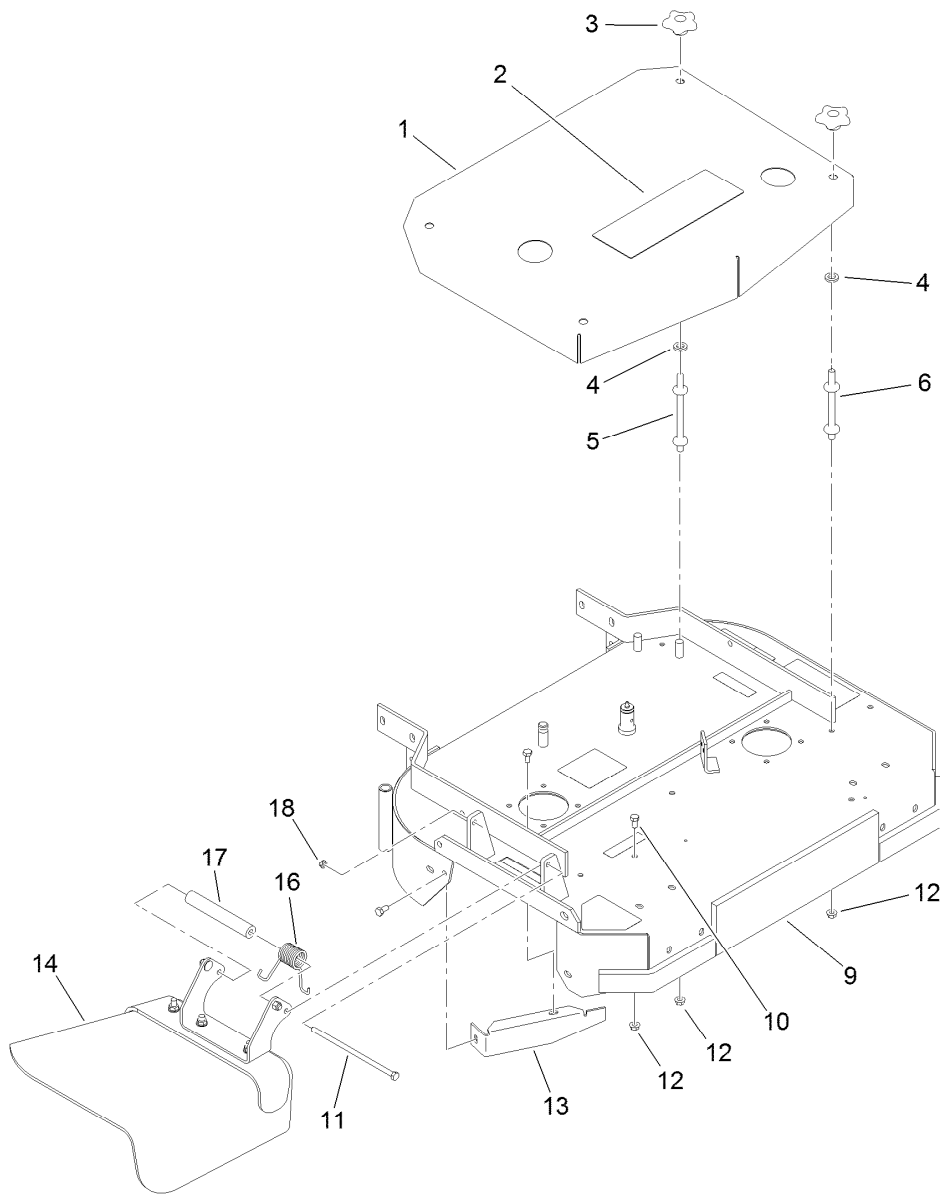

Deck and Shield Assembly

Ref.	Part Number	Qty.	Description
1	1-322149-01	1	Shield ASM
2	106-0710	1	Decal
3	106-4161	4	Knob-Handle
4	1-323417	4	Washer
5	1-303536	2	Stud-Shield, Belt (Long)
6	1-303537	2	Stud-Shield, Belt (Short)
9	110-6901	1	32 Inch Deck ASM
10	322-2	7	Screw-HH
11	322-50	1	Screw-HH
12	32128-20	11	Nut-HF
13	116-1730-01	1	Baffle-Dogleg
14	119-6529	1	Deflector ASM
16	108-4052	1	Spring-Torsion
17	105-4622	1	Spacer
18	3296-47	1	Nut-Lock, NI

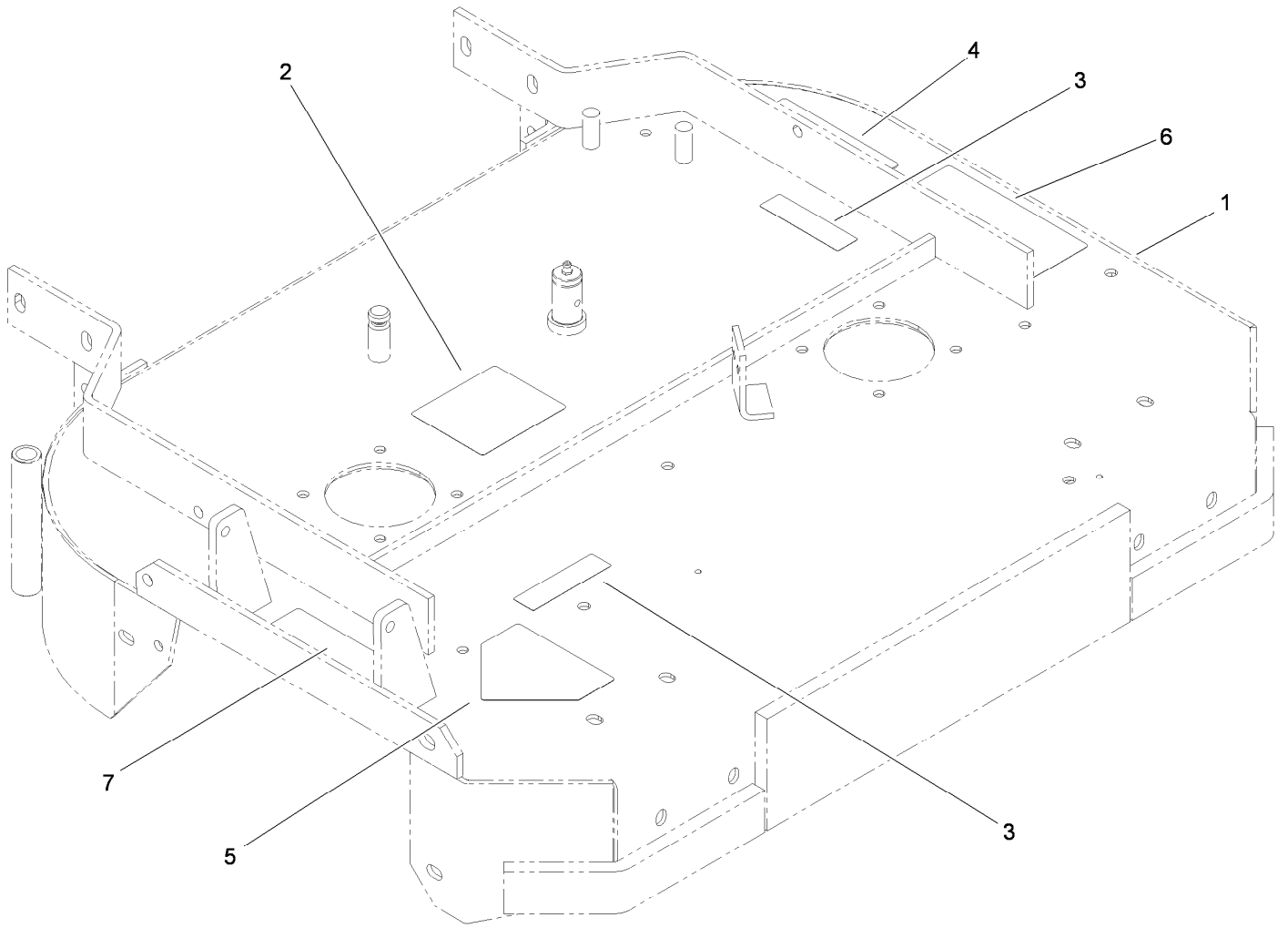

Deck Decal Assembly No. 110-6901

<i>Ref.</i>	<i>Part Number</i>	<i>Qty.</i>	<i>Description</i>
1		1	Deck ●
2	98-3296	1	Decal-Routing, Belt
3	98-5954	2	Decal-Cover, Missing
4	98-5130	1	Decal-Torque, Bolt
5	1-403005	1	Decal-Danger
6	66-1340	1	Decal-Danger, Thrown Object
7	104-8569	1	Decal-Warning

● Not serviced separately

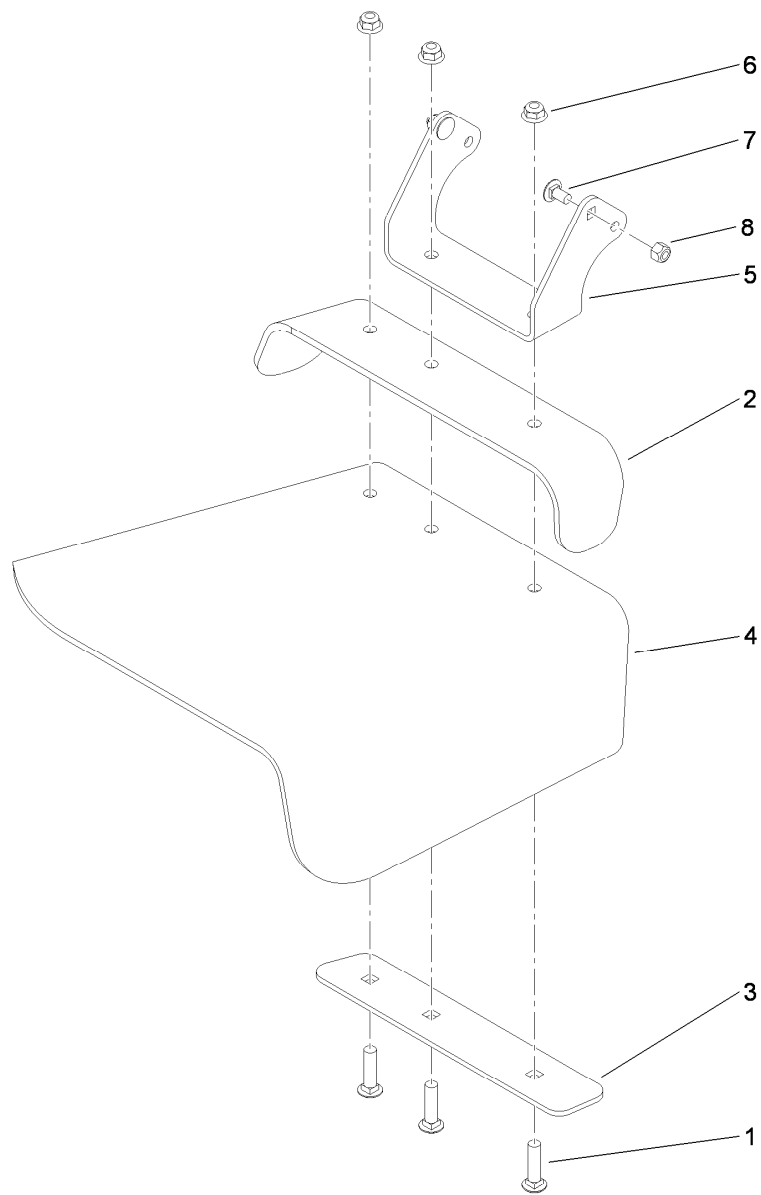

Deflector Assembly No. 119-6529

<i>Ref.</i>	<i>Part Number</i>	<i>Qty.</i>	<i>Description</i>
1	3231-4	3	Screw-CARR
2	107-4138-01	1	Strap-Deflector, Top
3	107-4139-01	1	Strap-Discharge
4	107-4137	1	Deflector-Rubber
5	119-6532-01	1	Bracket-Mounting, Deflector
6	104-8301	3	Nut-Flange, NI
7	3230-18	2	Screw-CARR
8	3296-29	2	Nut-Lock, NI

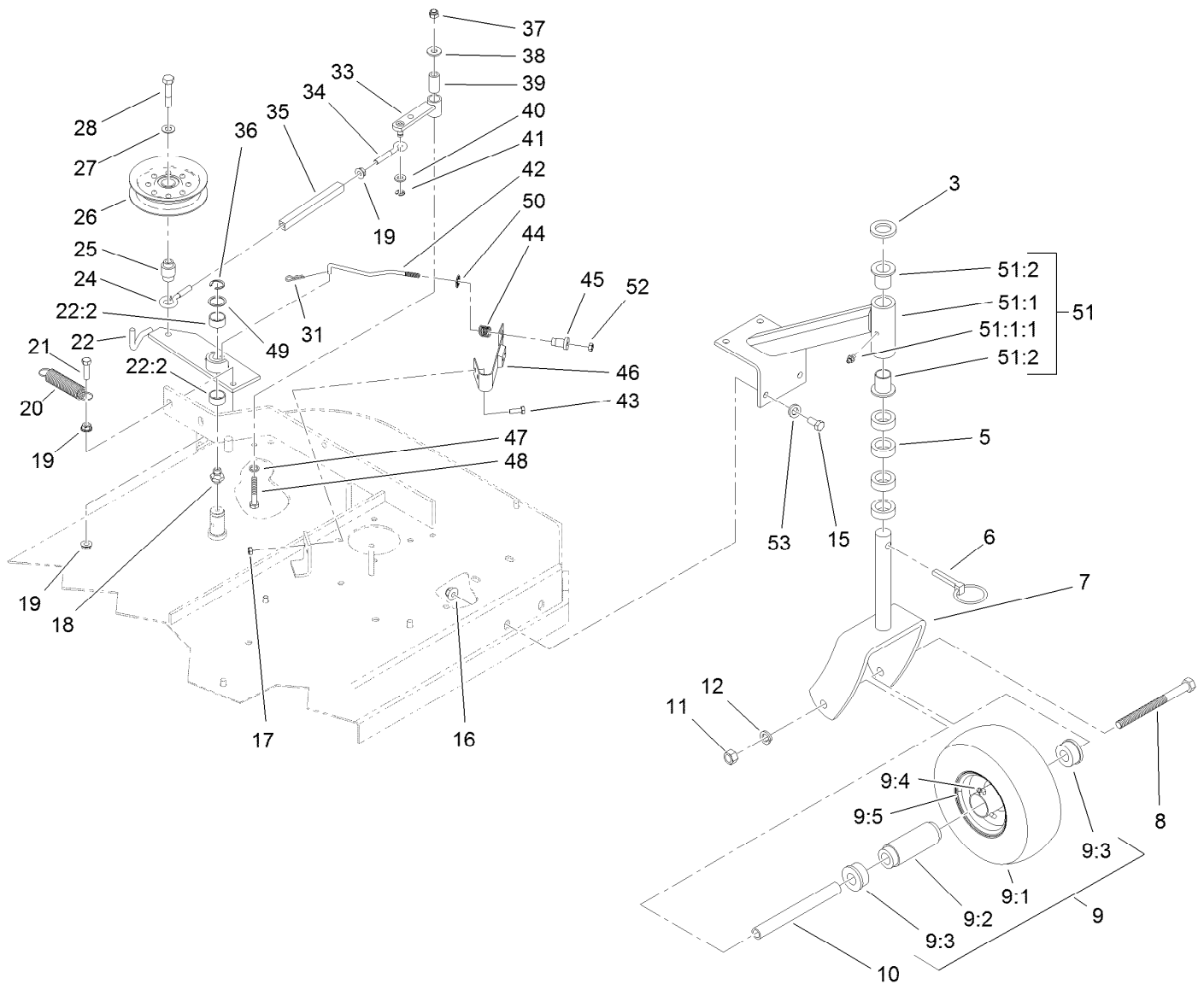

Idler Arm and Caster Wheel Assembly

Ref.	Part Number	Qty.	Description	Ref.	Part Number	Qty.	Description
3	1-513338	2	Washer-Flat	19	32128-20	3	Nut-HF
5	1-303314	8	Spacer-Caster	20	1-323071	1	Spring-Extension
6	1-809020	2	Pin	21	116-3515	1	Screw-HH, Special
7	1-322145-01	2	Fork	22	103-3600	1	Idler Arm ASM
8	325-20	2	Screw-HH	22:2	1-323729	2	Sleeve-Bearing
9	110-5023	2	Wheel And Tire ASM	24	1-303348	1	Eyebolt-Thread, LH
9:1		1	Tire ●	25	1-303434	1	Bushing-Engagement
9:2	1-513809	1	Bearing	26	116-3626	1	Pulley-Idler
9:3	1-513810	2	Bushing	27	98-5975	1	Washer-Belleville
9:4	302-61	1	Fitting-Grease	28	702809	1	Screw-HH
9:5		1	Wheel ●	31	1-806003	1	Pin-Cotter, Hair
10	1-513547	2	Spacer	33	1-322235	1	Arm-Assist
11	3217-9	2	Nut-HH	34	1-303238	1	Eyebolt-Thread, RH
12	3253-7	2	Washer-Lock	35	1-303236	1	Body-Turnbuckle
15	323-6	8	Screw-HH	36	32151-103	1	Ring-Retaining, EXT
16	104-8301	8	Nut-Flange, NI	37	3296-29	1	Nut-Lock, NI
17	3296-42	2	Nut-Lock, NI	38	3256-3	1	Washer-Flat
18	302-40	1	Fitting-Grease	39	1-403179	1	Tube-Pivot

● Not serviced separately

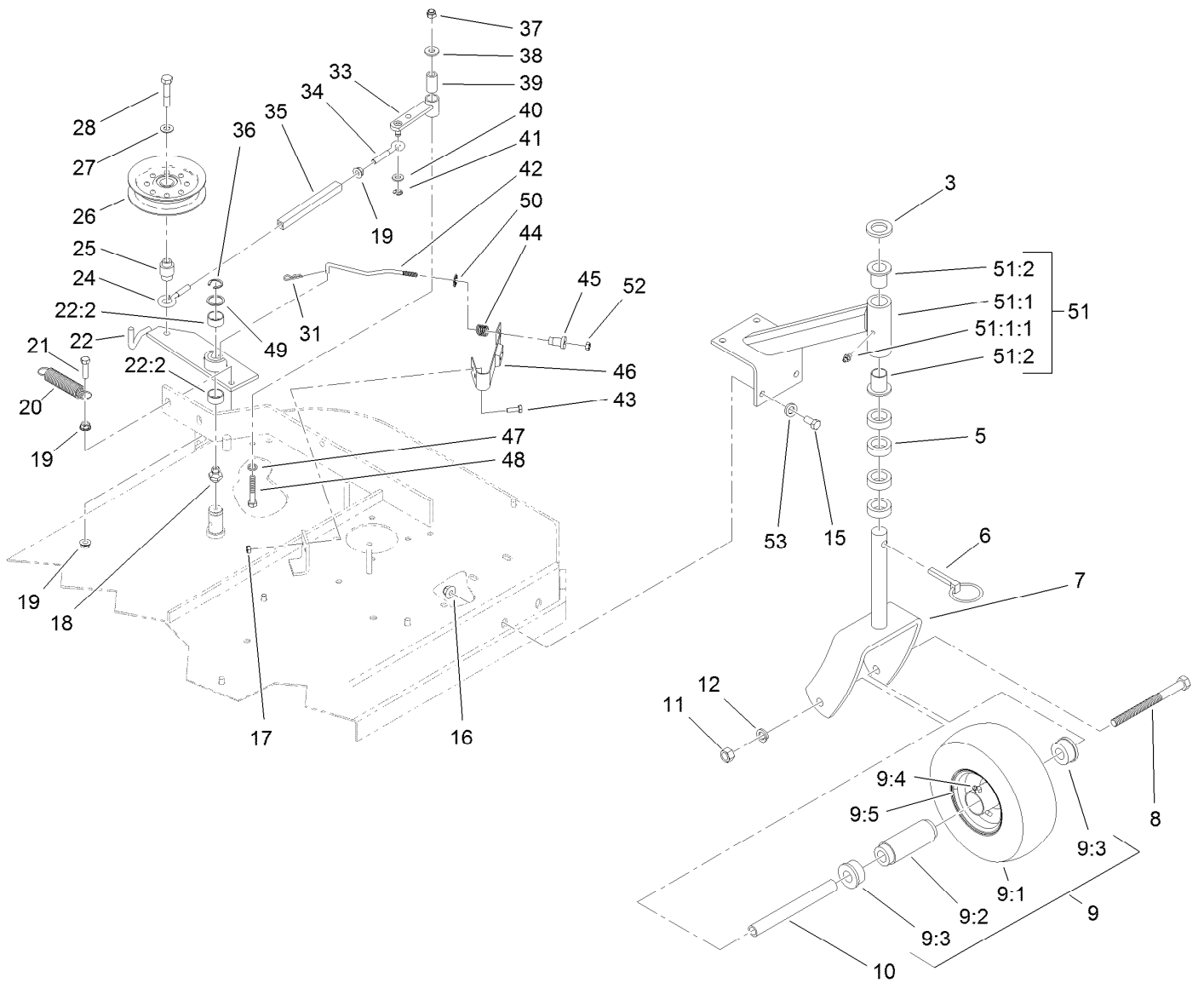

Idler Arm and Caster Wheel Assembly (continued)

Ref.	Part Number	Qty.	Description	Ref.	Part Number	Qty.	Description
40	3256-23	1	Washer-Flat	49	1-303352	1	Washer-Spindle
41	32120-35	1	Ring-Retaining, EXT	50	1-323748	1	Ring-Push On
42	1-323718	1	Rod-Brake	51	1-302203	2	Support ASM
43	321-4	2	Screw-HH	51:1		1	Support-Caster ●
44	1-323747	1	Spring-Compression	51:1:1	302-52	1	Fitting-Grease
45	1-323746	1	Spacer-Flanged	51:2	1-303514	2	Bearing-Flanged
46	1-324372	1	Pad And Spring ASM	52	3296-56	1	Nut-Lock, NI
47	1-303334	1	Washer-Spring	53	3256-24	8	Washer-Flat
48	322-10	1	Screw-HH				

● Not serviced separately

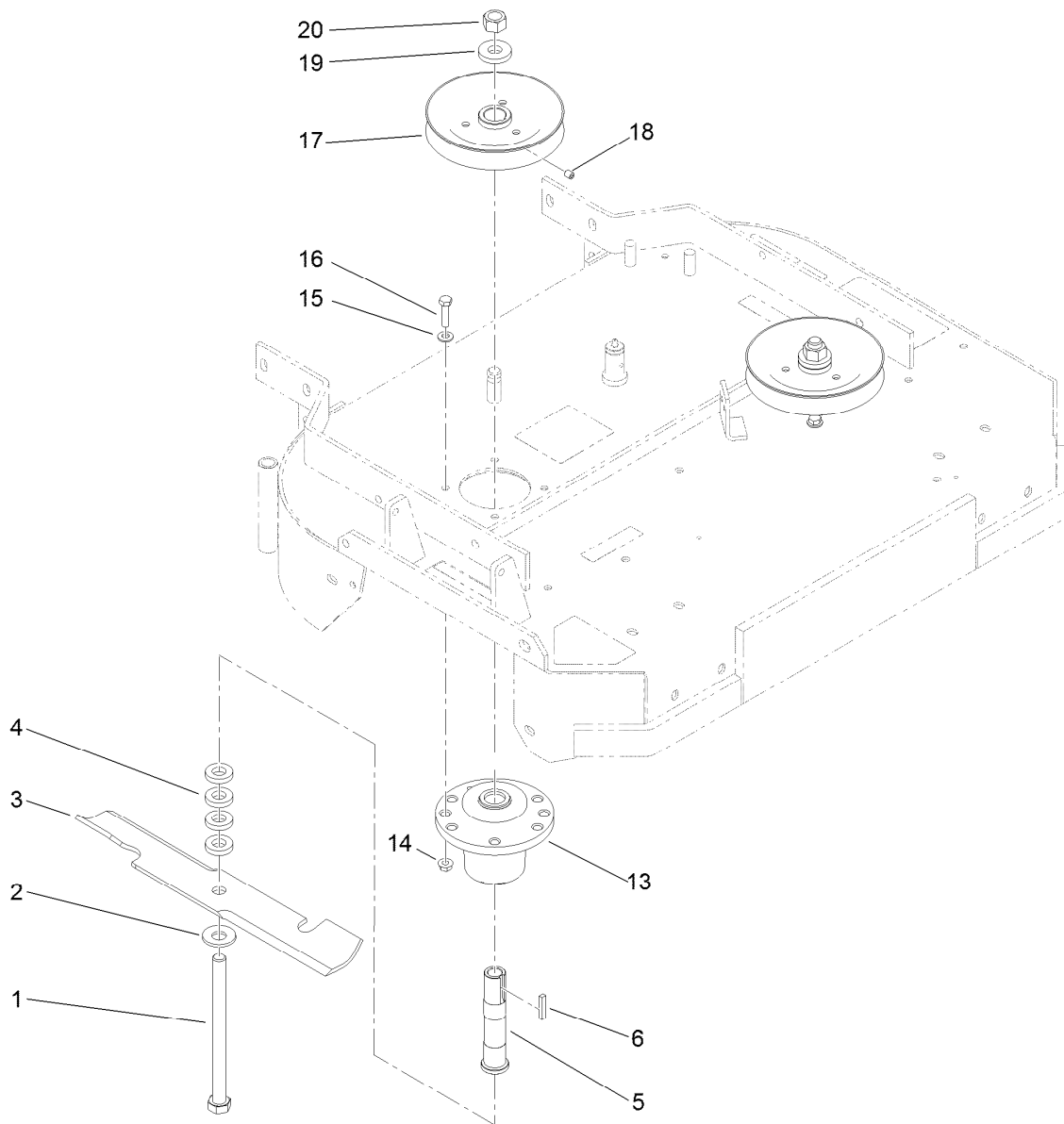

Spindle and Blade Assembly

<i>Ref.</i>	<i>Part Number</i>	<i>Qty.</i>	<i>Description</i>
1	1-800861	2	Screw-Cap, HH
2	1-513208	2	Washer-Spring
3	103-2527	2	Blade-Notched
4	1-323539	8	Spacer
5	1-323529	2	Tube-Spindle, Short
6	1-807267	2	Key
13	107-4065	2	Cutter Housing ASM
14	32128-20	8	Nut-HF
15	1-303334	8	Washer-Spring
16	322-6	8	Screw-HH
17	1-403183	2	Sheave
18	3246-18	2	Setscrew
19	1-323339	2	Washer-Retainer, Sheave
20	3219-6	2	Nut-Hex

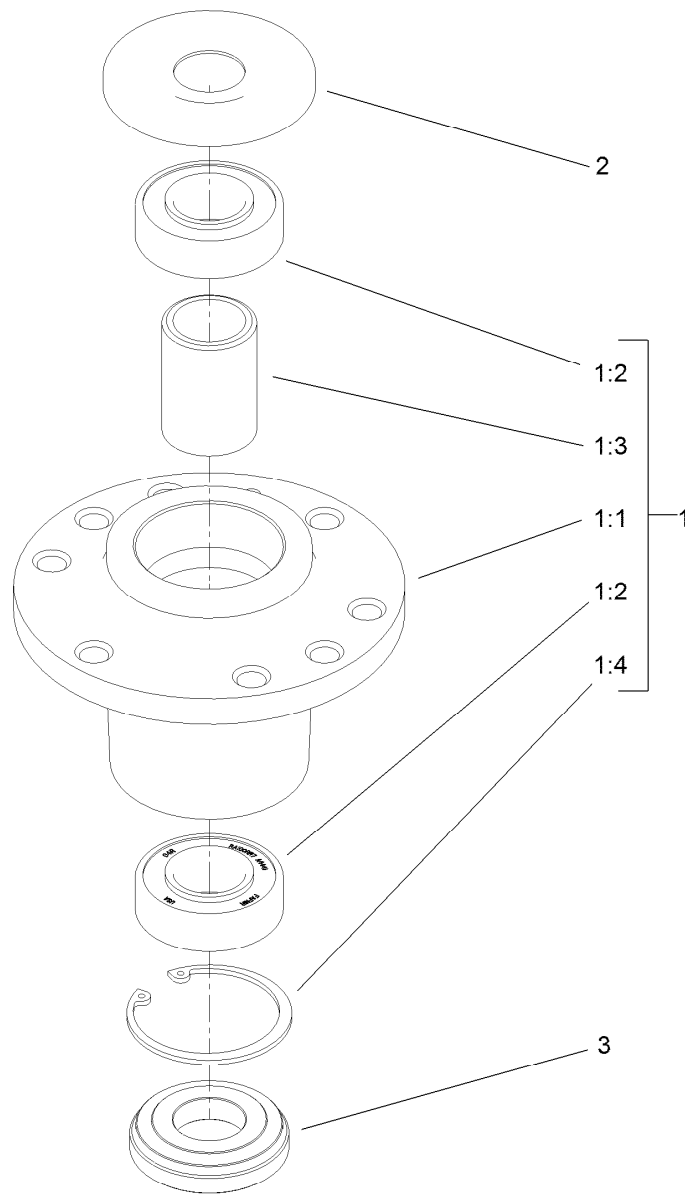

Cutter Housing Assembly No. 107-4065

<i>Ref.</i>	<i>Part Number</i>	<i>Qty.</i>	<i>Description</i>
1		1	Cutter Housing ASM ●
1:1	103-7975	1	Housing-Spindle
1:2	103-2477	2	Bearing-Jackshaft
1:3	103-2534	1	Spacer-Bearing
1:4	32120-8	1	Ring-Snap
2	103-1330	1	Guard-Bearing, Top
3	103-2535	1	Spacer-Guard, Bottom

● Not serviced separately

Attachments and Accessories

For 30672 Commercial Walk-Behind Mower Fixed Deck, T-Bar, Gear Drive with 32in Cutting Unit

Product Name	Model/Part
32in and 48in Fixed Deck Low Lift Blades.....	103-2507
Blade-Notched.....	103-2527
Atomic Blade and Decal Assembly	104-8595
Blade-Atomic, 16.25in (6 Pack)	110-0407
Spring-Extension	110-1119
32in Recycler Kit.....	110-4915
Soft Bag (3 Bushel).....	30198



Count on it.