



Count on it.

Parts Catalog

SGR-6 Stump Grinder

Model No. 22601—Serial No. 31000001 and Up

Model No. 22610—Serial No. 31100001 and Up

Model No. 22610G—Serial No. 31100001 and Up

Ordering Replacement Parts

To order replacement parts, please supply the part number, the quantity, and the description of each part desired.

Understanding Reference Numbers

Each identified part in an illustration has a reference number. The reference number for a part also appears in the parts list, along with other information about the part.

This catalog uses two special reference number formats, one to indicate parts in a service assembly and another to indicate the quantity of a given part in an illustration.

Service Assembly Reference Numbers

Parts in service assemblies have reference numbers in the form a:b. The a represents the reference number of the entire service assembly and the b represents a sequential number unique to each part within the service assembly.

For example, a wheel assembly might be identified by reference number 6, the tire by 6:1, the valve by 6:2, and the wheel by 6:3. When you order the assembly identified by reference number 6, you receive all parts identified by reference numbers 6:1, 6:2, and 6:3. However, you may also order any part individually. Reference numbers of this type appear in illustration and in parts lists.

Reference Numbers Indicating Quantity

In an illustration, if a reference number indicates more than one part, the reference number has the form nX y. The n represents the quantity of the part, the X is the multiplication symbol, and the y represents the reference number.

For example, in an illustration, the reference number 2X 37 means that two of the parts identified by reference number 37 are indicated.

List of Abbreviations

AR: as required

ASM: assembly

BBC: blade brake control

BHTF: button head thread forming

CARR: carriage

CCW: counter clockwise

CW: clockwise

DEG: degrees

DPA: Dual Point Adjustment

ECM: electronic control module

EXT: external

FH: flat head

GA: gauge

HD: heavy-duty

HF: hex flange

HH: hex head

HHF: hex head flange

HHFTF: hex head flange thread forming

HJ: hex jam

HLH: hex lag head

HOC: height-of-cut

HSBH: hex socket button head

HSFH: hex socket flat head

HSH: hex socket head

HWH: hex washer head

HWHTF: hex washer head thread forming

HYD: hydraulic

LH: left hand

LP: Liquid Propane

NI: nylon insert

NPTF: national pipe thread fine

PFH: phillips flat head

PPH: phillips pan head

PPHTF: phillips pan head thread forming

PRH: phillips round head

PTH: phillips truss head

PTO: power-take-off

RH: right hand

ROPS: roll-over protection system

RRB: rear roller brush

SFH: slotted fillister head

SHH: slotted hex head

SHWH: slotted hex washer head

SPH: slotted pan head

SQH: square head

SRH: slotted round head

STD: standard

TAP: self tapping

TTH: torx truss head

Contents

Engine and Frame Assembly	4
Handle Assembly	5
Cutter Wheel Assembly	6
Brake and Wheel Assembly	7
Flap Assembly	8
Belt Drive Assembly	9
Attachments and Accessories	10

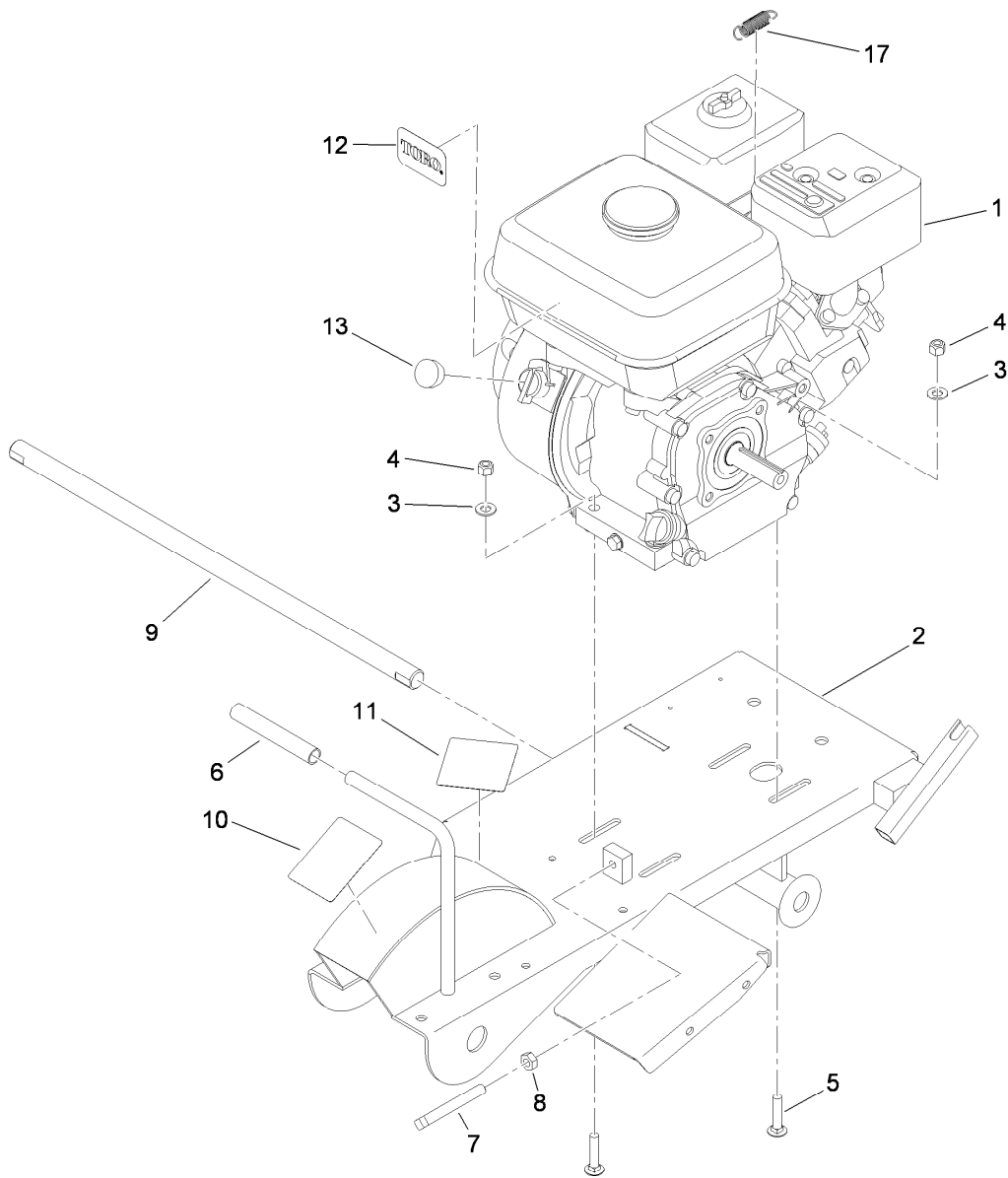

Engine and Frame Assembly

Ref.	Part Number	Qty.	Description
1		1	Engine-Honda, Gx200Ut Qxc9 ●■
2	120-1317-01	1	Frame ASM
3	3256-45	4	Washer-Flat
4	3296-29	4	Nut-Lock, NI
5	3230-4	4	Screw-CARR
6	112-2605	1	Grip-Rubber
7	119-4729	1	Screw-Set, SQH
8	3217-7	1	Nut-Hex
9	120-1795	1	Bar-Axle, Wheel
10	119-4690	1	Decal-Danger
11	119-4693	1	Decal-Caution
12	98-3206	1	Decal
13	120-1887	1	Plug-Engine
17	112228	1	Spring-Extension

● Not serviced separately

■ Obtain parts from www.honda-engines.com

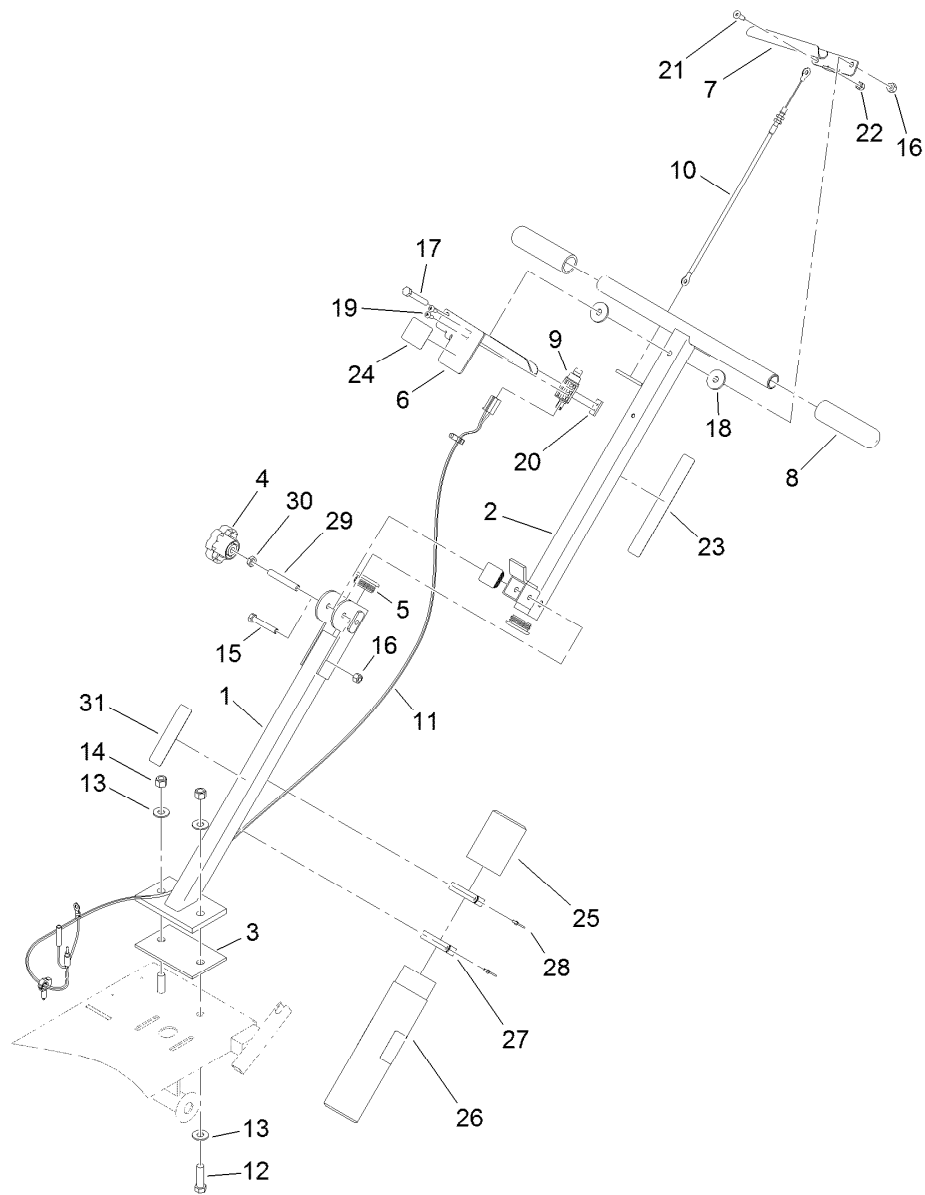

Handle Assembly

Ref.	Part Number	Qty.	Description	Ref.	Part Number	Qty.	Description
1	120-1323-01	1	Lower Handle ASM	16	3296-29	2	Nut-Lock, NI
2	120-1322-01	1	Upper Handle ASM	17	322-11	1	Screw-HH
3	120-1324	1	Gasket-Handle	18	107675	2	Washer
4	109-1092	1	Knob	19	1-803071	2	Screw
5	120-1302	3	Plug-Tube	20	1-633181	1	Plate-Tapped
6	120-1355-03	1	Plunger Handle ASM	21	116-0606	1	Screw-Torx
7	120-1359-03	1	Throttle Handle ASM	22	3296-42	1	Nut-Lock, NI
8	120-1333	2	Handle-Grip	23	119-4691	1	Decal-Caution
9	120-1292	1	Switch-Plunger, Nc (W/Cover)	24	119-4722	1	Decal-Engage
10	120-1375	1	Cable-Throttle	25	104-7048	1	Cap-Housing
11	120-1369	1	Harness-Wire	26	104-7050	1	Tube-Manual
12	324-6	2	Screw-HH	27	2412-120	2	R-Clamp
13	3256-4	4	Washer-Flat	28	3269-17	2	Rivet-Pop
14	3296-48	2	Nut-Lock, NI	29	120-0909	1	Screw-HSH
15	322-10	1	Screw-HH	30	3218-3	1	Nut-Jam
				31	117-2718	1	Decal-Arrester, Spark

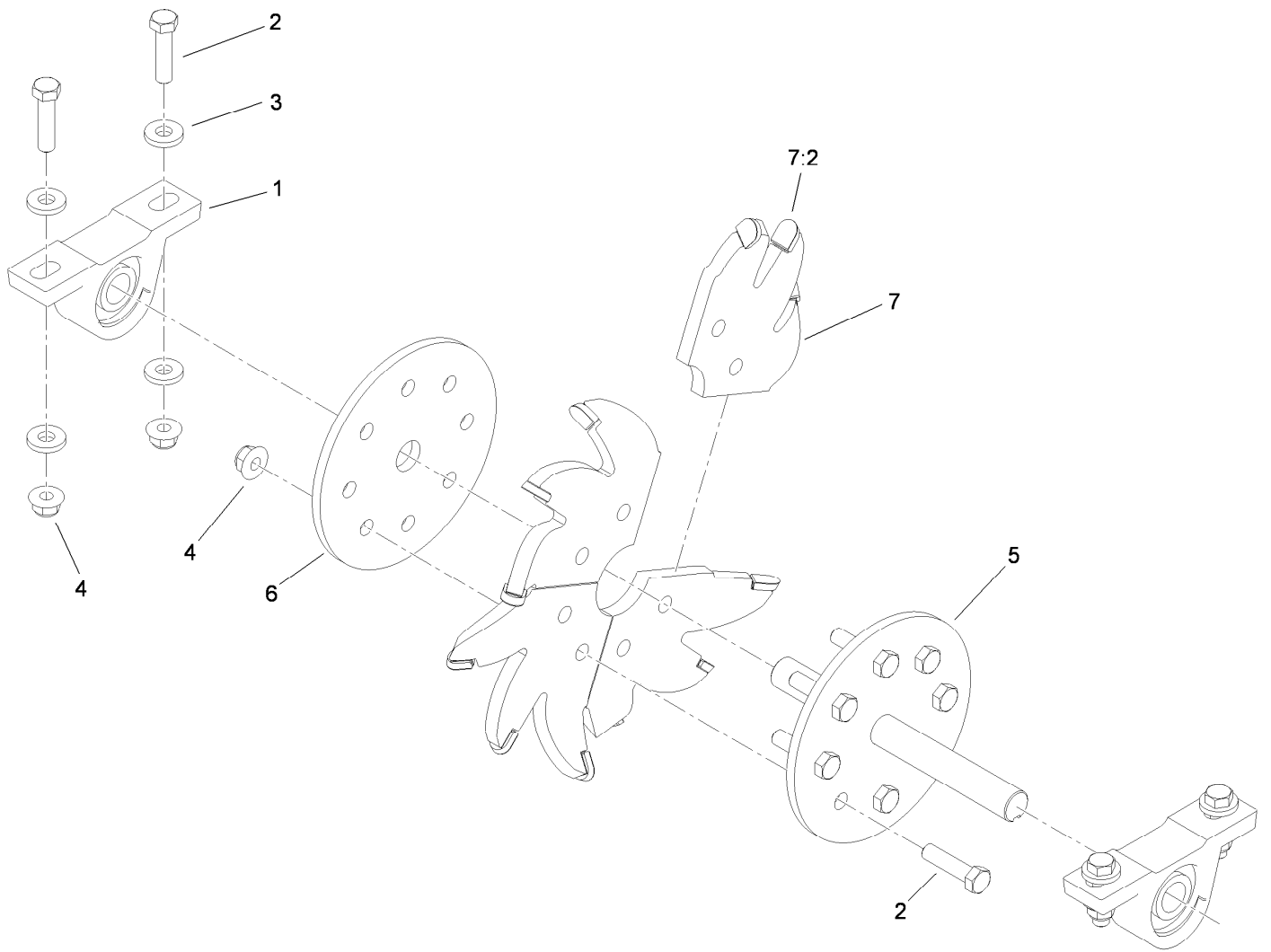

Cutter Wheel Assembly

<i>Ref.</i>	<i>Part Number</i>	<i>Qty.</i>	<i>Description</i>
1	120-1373	2	Bearing ASM
2	323-8	12	Screw-HH
3	71-9310	8	Spacer
4	104-8301	12	Nut-Flange, NI
5	120-1372	1	Blade Shaft ASM
6	120-1370-03	1	Plate-Flange, Shaft
7	119-4702-03	4	Blade-Grinder
7:2	119-4705	3	Tip-Carbide

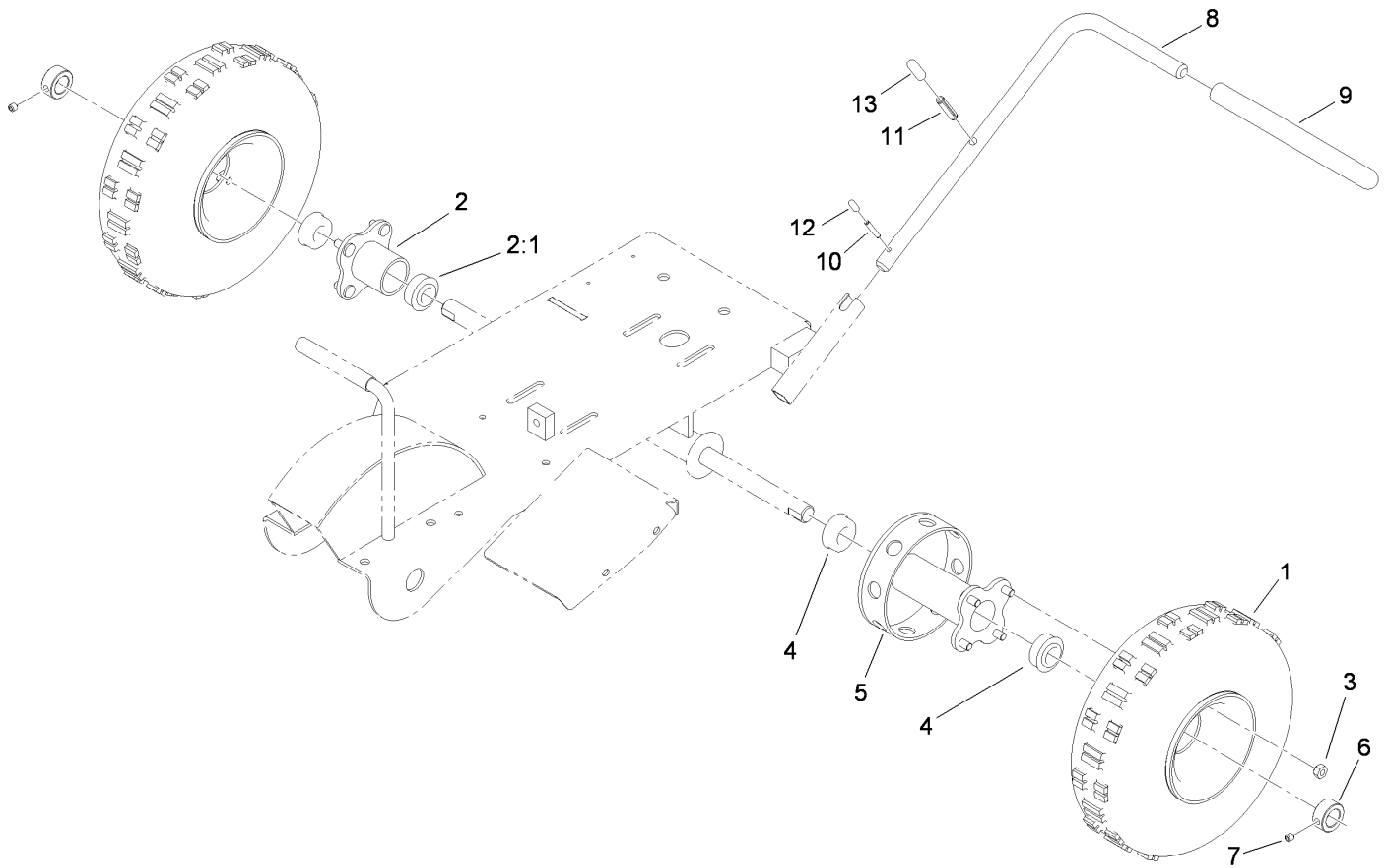

Brake and Wheel Assembly

<i>Ref.</i>	<i>Part Number</i>	<i>Qty.</i>	<i>Description</i>
1	120-1288	2	Tire ASM
2	120-1295	1	Hub
2:1	120-1296	2	Bearing-Wheel
3	120-1304	8	Nut-Wheel
4	120-1296	2	Bearing-Wheel
5	120-1325-03	1	Brake Hub ASM
6	120-1294	2	Collar-Set
7	3246-2	2	Screw-Set, HSH
8	120-1309-01	1	Handle-Brake
9	119-0222	1	Grip
10	32121-6	1	Pin-Roll, Slotted
11	32121-25	1	Pin-Roll
12	119-4741	1	Cap-Lower
13	119-4742	1	Cap-Upper

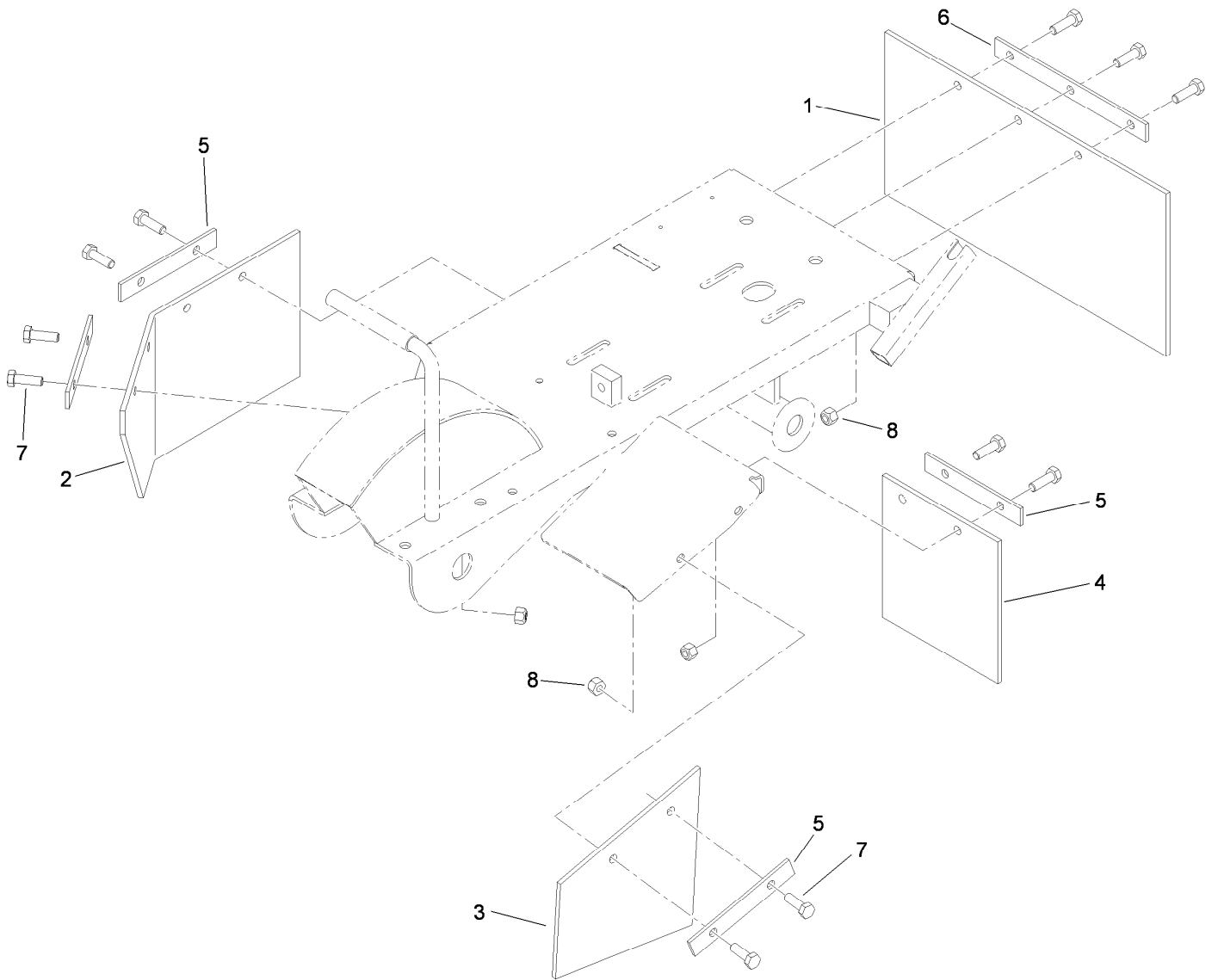

Flap Assembly

<i>Ref.</i>	<i>Part Number</i>	<i>Qty.</i>	<i>Description</i>
1	120-1311	1	Flap-Rear
2	120-1312	1	Flap-Right
3	120-1313	1	Flap-Wing
4	120-1314	1	Flap-Wing, Rear
5	120-1315-01	4	Plate-Mounting, Flap
6	120-1316-01	1	Plate-Mounting, Flap (Rear)
7	322-5	11	Screw-HH
8	3296-29	11	Nut-Lock, NI

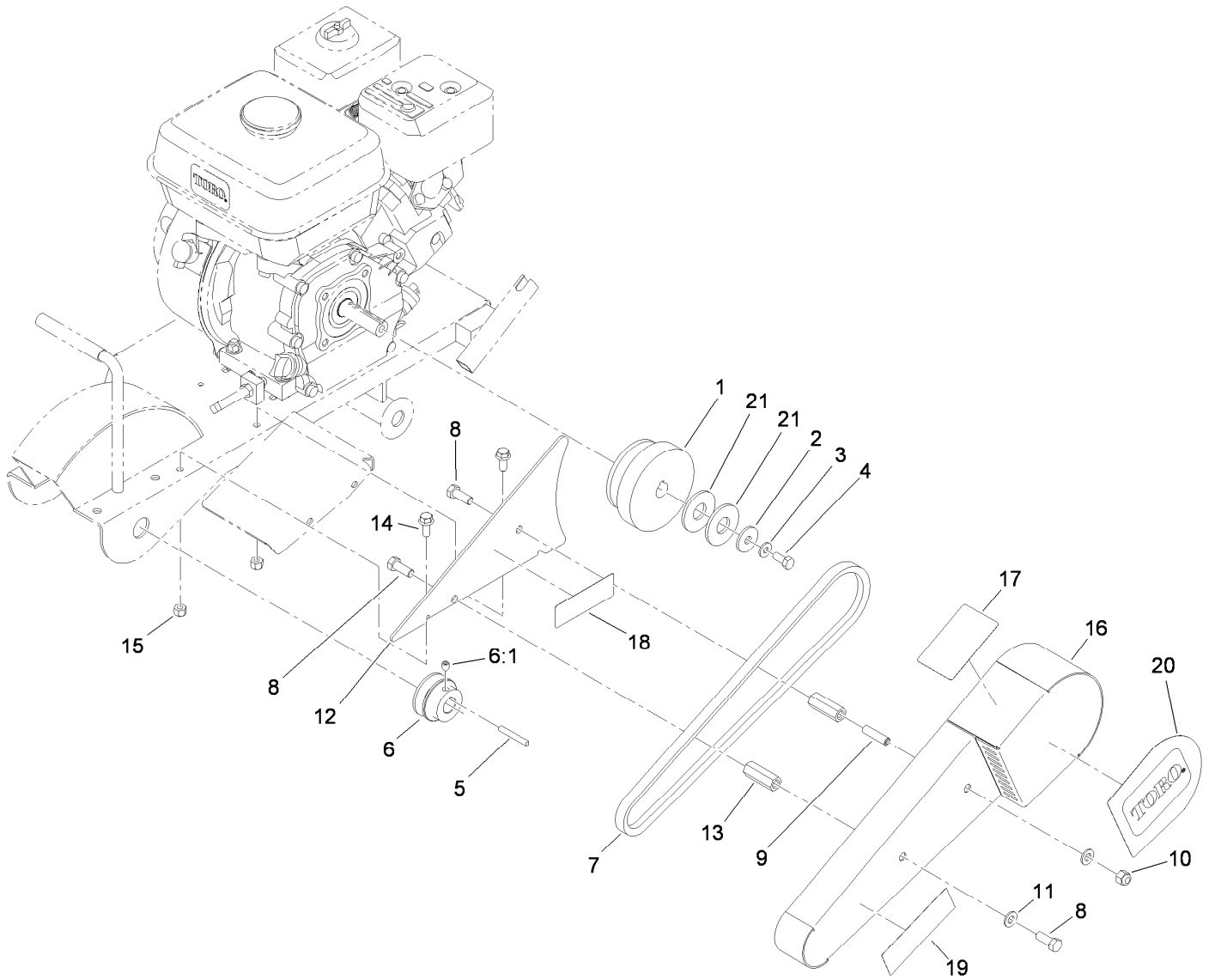

Belt Drive Assembly

Ref.	Part Number	Qty.	Description	Ref.	Part Number	Qty.	Description
1	120-1215	1	Clutch-Centrifugal	11	3256-38	2	Washer-Flat
2	63-8410	1	Washer	12	120-1326-01	1	Plate-Guard, Inner
3	3256-2	1	Washer-Flat	13	120-1332	2	Spacer-Guard, Belt
4	3210-3	1	Screw-HH	14	3234-47	2	Screw-HHF
5	7-0036	2	Key-Square	15	3296-29	2	Nut-Lock, NI
6	120-1303	1	Pulley-Front	16	120-1344-01	1	Outer Belt Guard ASM
6:1	3246-3	1	Screw-HSH	17	119-4692	1	Decal-Caution
7	120-1374	1	Belt-Drive	18	117-4979	1	Decal-Warning, Shields (Ce)
8	323-6	3	Screw-HH	19	120-1815	1	Decal
9	3247-8	1	Screw-Set, HSH	20	119-4723	1	Decal
10	3296-39	1	Nut-Lock, NI	21	3256-8	2	Washer-Flat

Attachments and Accessories

For 22610 SGR-6 Stump Grinder

Product Name

Model/Part

Stump Grinder Blade Tote.....	22607
Blade Tote (Set of 6, Sharpened).....	22607-SH

Notes:



Count on it.