



Count on it.

Operator's Manual

DH 220 Lawn Tractor

Model No. 74596—Serial No. 312000001 and Up

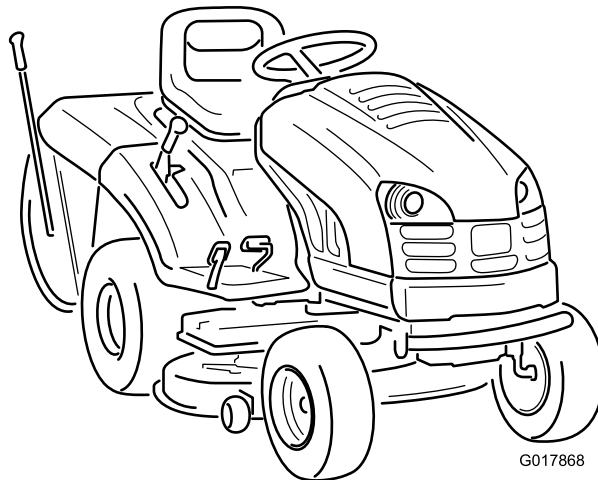

G017868



This product complies with all relevant European directives. For details, see the separate product specific Declaration of Conformity (DOC) sheet.

Introduction

This rotary-blade, riding lawn mower is intended to be used by residential homeowners. It is designed primarily for cutting grass on well-maintained lawns on residential properties. It is not designed for cutting brush or for agricultural uses.

Read this information carefully to learn how to operate and maintain your product properly and to avoid injury and product damage. You are responsible for operating the product properly and safely.

You may contact Toro directly at www.Toro.com for product and accessory information, help finding a dealer, or to register your product.

Whenever you need service, genuine Toro parts, or additional information, contact an Authorized Service Dealer or Toro Customer Service and have the model and serial numbers of your product ready. Figure 1 identifies the location of the model and serial numbers on the product. Write the numbers in the space provided.

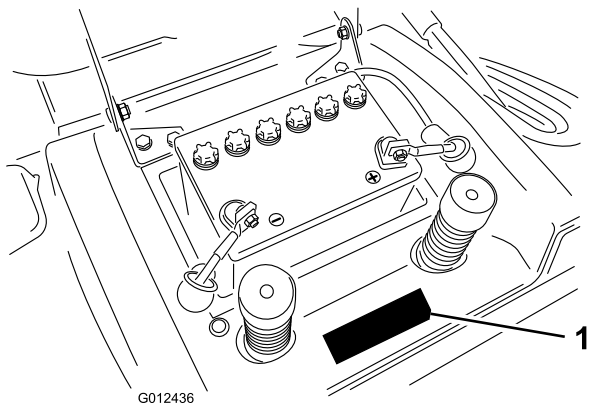

Figure 1

1. Model and serial number location

Model No. _____
Serial No. _____

This manual identifies potential hazards and has safety messages identified by the safety alert symbol (Figure 2), which signals a hazard that may cause serious injury

or death if you do not follow the recommended precautions.



Figure 2

1. Safety alert symbol

This manual uses 2 other words to highlight information. **Important** calls attention to special mechanical information and **Note** emphasizes general information worthy of special attention.

Contents

Introduction.....	2	Servicing the Battery.....	26
Safety.....	4	Drive System Maintenance	28
Safe Operation Practices for Riding Rotary		Checking the Tire Pressure	28
Lawn Mowers.....	4	Servicing the Brake.....	28
Toro Riding Mower Safety	5	Servicing the Grass Collector.....	29
Sound Pressure.....	6	Removing the Grass Collector	29
Sound Power.....	6	Installing the Grass Collector.....	29
Vibration.....	6	Cleaning the Grass Collector and Tunnel.....	29
Slope Indicator.....	7	Mower Deck Maintenance	30
Safety and Instructional Decals	8	Servicing the Blades.....	30
Product Overview	10	Removing the Mower	31
Controls.....	10	Installing the Mower.....	31
Specifications	10	Storage.....	32
Operation.....	10	Troubleshooting.....	33
Adding Fuel	10	Schematics	35
Using Stabilizer/Conditioner.....	11		
Filling the Fuel Tank.....	11		
Checking the Engine Oil Level.....	11		
Using the Parking Brake.....	11		
Positioning the Seat	11		
Operating the Headlights.....	12		
Hour Meter	12		
Using the Blade Control (PTO).....	12		
Setting the Height of Cut	12		
Starting the Engine.....	12		
Stopping the Engine.....	13		
Using the Safety Interlock System	13		
Testing the Safety Interlock System	15		
Pushing the Machine Manually.....	15		
Driving the Machine Forward or			
Backward	15		
Stopping the Machine.....	16		
Using the Recycle on Demand	16		
Emptying the Grass Collector.....	16		
Rear-discharging the Grass Clippings	17		
Using the Optional Towing Hitch	18		
Operating Tips	18		
Maintenance.....	19		
Recommended Maintenance Schedule(s)	19		
Lubrication.....	19		
Greasing and Lubricating the Machine	19		
Engine Maintenance.....	20		
Servicing the Air Cleaner	20		
Servicing the Engine Oil.....	21		
Servicing the Spark Plug	23		
Fuel System Maintenance	24		
Draining the Fuel Tank.....	24		
Replacing the Fuel Filter	25		
Electrical System Maintenance.....	25		
Replacing the Headlight Bulbs	25		
Replacing the Fuses	26		

Safety

Safe Operation Practices for Riding Rotary Lawn Mowers

Read and understand the contents of this manual before operating the machine.

The safety alert symbol (Figure 2) is used to alert you to potential personal injury hazards. Obey all safety messages that follow this symbol to avoid possible injury or death.

The following instructions are from the CEN standard EN 836:1997.

This product is capable of amputating hands and feet and of throwing objects. Always follow all safety instructions to avoid serious injury or death.

Training

- Read the instructions carefully. Be familiar with the controls and the proper use of the equipment.
- Never allow children or people unfamiliar with these instructions to use the lawn mower. Local regulations can restrict the age of the operator.
- Never mow while people, especially children, or pets are nearby.
- Keep in mind that the operator or user is responsible for accidents or hazards occurring to other people or their property.
- Do not carry passengers.
- All drivers should seek and obtain professional and practical instruction. Such instruction should emphasize:
 - the need for care and concentration when working with ride-on machines;
 - control of a ride-on machine sliding on a slope will not be regained by the application of the brake. The main reasons for loss of control are:
 - ◇ insufficient wheel grip;
 - ◇ being driven too fast;
 - ◇ inadequate braking;
 - ◇ the type of machine is unsuitable for its task;
 - ◇ lack of awareness of the effect of ground conditions, especially slopes;
 - ◇ incorrect hitching and load distribution.

Preparation

- While mowing, always wear substantial footwear and long trousers. Do not operate the equipment when barefoot or wearing open sandals.
- Thoroughly inspect the area where the equipment is to be used and remove all objects which may be thrown by the machine.
- **Warning**—Fuel is highly flammable.
 - Store fuel in containers specifically designed for this purpose.
 - Refuel outdoors only and do not smoke while refuelling.
 - Add fuel before starting the engine. Never remove the cap of the fuel tank or add fuel while the engine is running or when the engine is hot.
 - If fuel is spilled, do not attempt to start the engine but move the machine away from the area of spillage and avoid creating any source of ignition until fuel vapors have dissipated.
 - Replace all fuel tanks and container caps securely.
- Replace faulty silencers.
- Before using, always visually inspect to see that the blades, blade bolts and cutter assembly are not worn or damaged. Replace worn or damaged blades and bolts in sets to preserve balance.
- On multi-bladed machines, take care as rotating one blade can cause other blades to rotate.

Operation

- Do not operate the engine in a confined space where dangerous carbon monoxide fumes can collect.
- Mow only in daylight or in good artificial light.
- Before attempting to start the engine, disengage all blade attachment clutches and shift into neutral.
- Do not use on slopes of more than
 - 10° when mowing on side hills;
 - 15° when mowing uphill or downhill.
- Remember there is no such thing as a safe slope. Travel on grass slopes requires particular care. To guard against overturning:
 - do not stop or start suddenly when going up or downhill;
 - machine speeds should be kept low on slopes and during tight turns;

- stay alert for humps and hollows and other hidden hazards;
- never mow across the face of the slope, unless the lawn mower is designed for this purpose.
- Use care when pulling loads or using heavy equipment.
 - Use only approved drawbar hitch points.
 - Limit loads to those you can safely control.
 - Do not turn sharply. Use care when reversing.
 - Use counterweight(s) or wheel weights when suggested in the instruction handbook.
- Lightning can cause severe injury or death. If you see lightning or hear thunder in the area, do not operate the machine; seek shelter.
- Watch out for traffic when crossing or near roadways.
- Stop the blades rotating before crossing surfaces other than grass.
- When using any attachments, never direct discharge of material toward bystanders nor allow anyone near the machine while in operation.
- Never operate the machine with damaged guards or without safety protective devices in place.
- Do not change the engine governor settings or overspeed the engine. Operating the engine at excessive speed can increase the hazard of personal injury.
- Before leaving the operator's position:
 - disengage the power take-off and lower the attachments;
 - change into neutral and set the parking brake;
 - stop the engine and remove the key.
- Disengage drive to attachments, stop the engine, and disconnect the spark plug wire(s) or remove the ignition key
 - before clearing blockages or unclogging chute;
 - before checking, cleaning or working on the lawn mower;
 - after striking a foreign object. Inspect the lawn mower for damage and make repairs before restarting and operating the equipment;
 - if the machine starts to vibrate abnormally (check immediately).
- Disengage drive to attachments when transporting or not in use.
- Stop the engine and disengage drive to attachment
 - before refuelling;
 - before removing the grass catcher;
 - before making height adjustment unless adjustment can be made from the operator's position.
- Reduce the throttle setting during engine run-out and, if the engine is provided with a shut-off valve, turn the fuel off at the conclusion of mowing.

Maintenance and Storage

- Keep all nuts, bolts and screws tight to be sure the equipment is in safe working condition.
- Never store the equipment with fuel in the tank inside a building where fumes can reach an open flame or spark.
- Allow the engine to cool before storing in any enclosure.
- To reduce the fire hazard, keep the engine, silencer, battery compartment and fuel storage area free of grass, leaves, or excessive grease.
- Check the grass catcher frequently for wear or deterioration.
- Replace worn or damaged parts for safety.
- If the fuel tank has to be drained, this should be done outdoors.
- On multi-bladed machines, take care as rotating one blade can cause other blades to rotate.
- When machine is to be parked, stored, or left unattended, lower the cutting means unless a positive mechanical lock is used.

Toro Riding Mower Safety

The following paragraph contains safety information specific to Toro products that is not included in the CEN standard.

Use only Toro-approved attachments. The warranty may be voided if you use the machine with unapproved attachments.

Sound Pressure

This unit has a sound pressure level at the operator's ear of 82 dBA, which includes an Uncertainty Value (K) of 1 dBA. The sound pressure level was determined according to the procedures outlined in EN 836.

Sound Power

This unit has a guaranteed sound power level of 100 dBA, which includes an Uncertainty Value (K) of 1 dBA. The sound power level was determined according to the procedures outlined in ISO 11094.

Vibration

Hand-Arm

- Measured vibration level for right hand = 2.8 m/s²
- Measured vibration level for left hand = 2.8 m/s²
- Uncertainty Value (K) = 1.4 m/s²

Measured values were determined according to the procedures outlined in EN 836.

Whole Body

- Measured vibration level = 0.3 m/s²
- Uncertainty Value (K) = 0.15 m/s²

Measured values were determined according to the procedures outlined in EN 836.

Slope Indicator



2

G011841

Figure 3

This page may be copied for personal use.

1. The maximum slope you can safely operate the machine on is **15 degrees**. Use the slope chart to determine the degree of slope of hills before operating. **Do not operate this machine on a slope greater than 15 degrees**. Fold along the appropriate line to match the recommended slope.
2. Align this edge with a vertical surface, a tree, building, fence pole, etc.
3. Example of how to compare slope with folded edge.

Safety and Instructional Decals



Safety decals and instructions are easily visible to the operator and are located near any area of potential danger. Replace any decal that is damaged or lost.

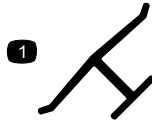

Manufacturer's Mark

1. Indicates the blade is identified as a part from the original machine manufacturer.

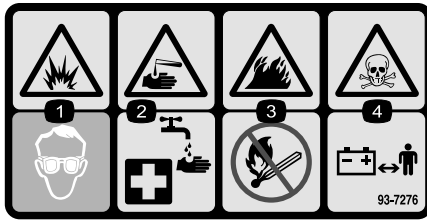

93-7276

- | | |
|--|--|
| 1. Explosion hazard—wear eye protection. | 3. Fire hazard—no fire, open flames, or smoking. |
| 2. Caustic liquid/chemical burn hazard—to perform first aid, flush with water. | 4. Poison hazard—keep children a safe distance from the battery. |

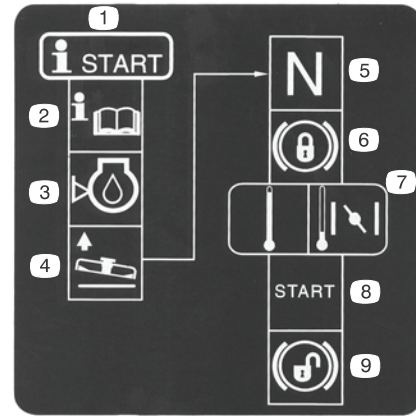

104-3238

- | | |
|--|---|
| 1. Starting procedure | 6. Lock the parking brake. |
| 2. Read the <i>Operator's Manual</i> . | 7. If the engine is cold, move the throttle control lever to Choke. |
| 3. Check the engine oil level. | 8. Start the engine. |
| 4. Raise the mower. | 9. Unlock the parking brake. |
| 5. Put the tractor in neutral. | |

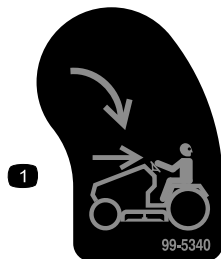

99-5340

1. KeyChoice—turn to enable reverse mowing.



104-3243

- | | |
|---|---|
| 1. To drive the machine, push the lever in. | 2. To push the machine, pull the lever out. |
|---|---|



104-3237

1. Parking brake

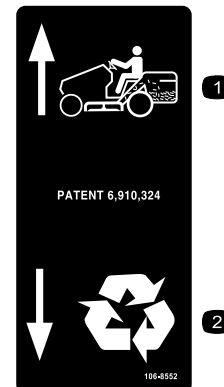

106-8552

- | | |
|------------------|------------|
| 1. Collect grass | 2. Recycle |
|------------------|------------|

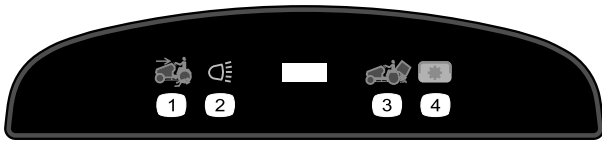

111-5630

1. Moving in reverse enabled
2. Lights
3. Empty the grass collector
4. Power Take-off (PTO)

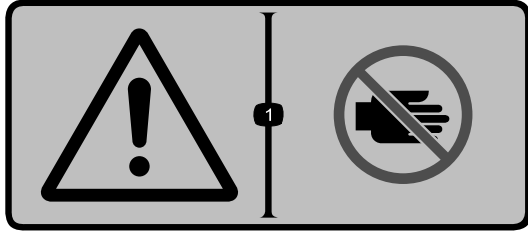

111-5941

1. Warning—keep hands away from moving parts.



111-5942

1. Height-of-cut settings

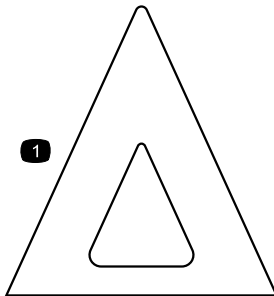

111-5953

1. Height-of-cut indicator

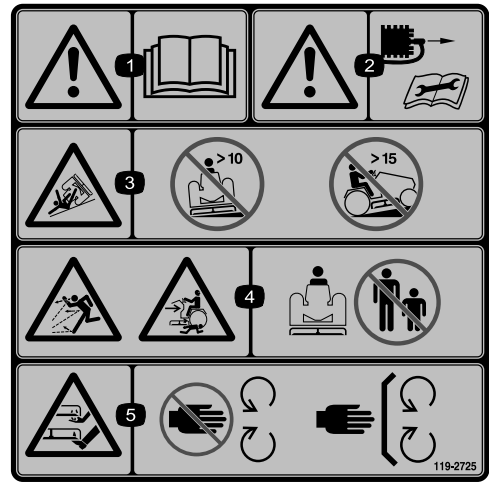

119-2725

1. Warning—read the *Operator's Manual*.
2. Warning—remove the spark plug wire before performing any maintenance on the machine.
3. Tipping hazard—do not operate on slopes greater than 10 degrees.
4. Thrown object hazard; crushing hazard, bystanders—keep bystanders a safe distance from the machine.
5. Cutting hazard of hand or foot—stay away moving parts, keep all guards and shields in place.



119-2726

1. Thrown object hazard—keep bystanders a safe distance from the machine.
2. Cutting hazard of hand or foot—stay away moving parts, keep all guards and shields in place.



119-2730

1. Crushing/dismemberment hazard of bystanders—do not turn the key while children are present; keep children a safe distance from the machine.

Product Overview

Controls

Become familiar with the controls (Figure 4) before you start the engine and operate the machine.

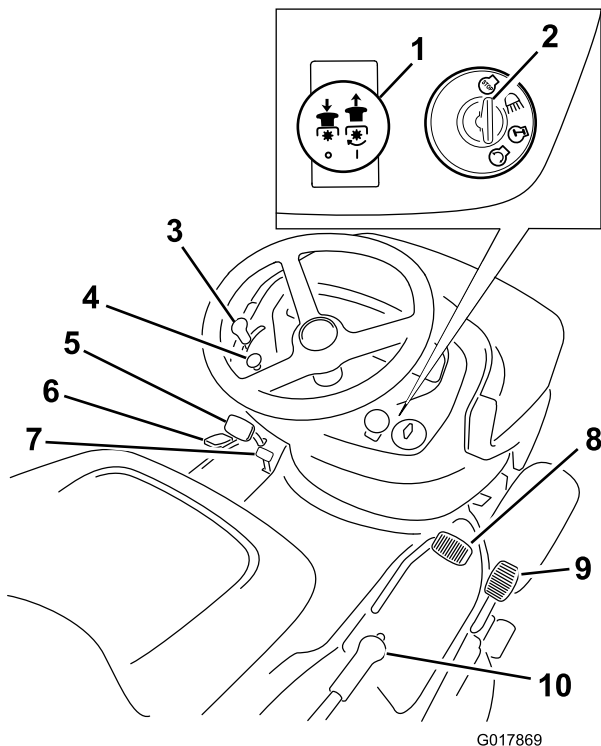

Figure 4

- | | |
|-----------------------------|----------------------------|
| 1. Blade control (PTO) knob | 6. Recycle-on-demand lever |
| 2. Ignition switch | 7. Parking brake |
| 3. Throttle control lever | 8. Forward speed pedal |
| 4. Choke knob | 9. Reverse speed pedal |
| 5. Brake pedal | 10. Height-of-cut lever |

Specifications

Weight	Length	Width	Height
256 kg	260 cm	110 cm	119 cm

Operation

Note: Determine the left and right sides of the machine from the normal operating position.

Adding Fuel

Use unleaded regular gasoline suitable for automotive use (87 pump octane minimum). You may use leaded, regular gasoline if unleaded gasoline is not available.

Important: Never use methanol, gasoline containing methanol, or gasohol containing more than 10% ethanol because the fuel system could be damaged. Do not mix oil with gasoline.

⚠ DANGER

In certain conditions, gasoline is extremely flammable and highly explosive. A fire or explosion from gasoline can burn you and others and can damage property.

- Fill the fuel tank outdoors, in an open area, when the engine is cold. Wipe up any gasoline that spills.
- Do not fill the fuel tank completely full. Add gasoline to the fuel tank until the level is 1/4 to 1/2 inch (6 to 13 mm) below the bottom of the filler neck. This empty space in the tank allows gasoline to expand.
- Never smoke when handling gasoline, and stay away from an open flame or where gasoline fumes may be ignited by a spark.
- Store gasoline in an approved container and keep it out of the reach of children. Never buy more than a 30-day supply of gasoline.
- Always place gasoline containers on the ground away from your vehicle before filling.
- Do not fill gasoline containers inside a vehicle or on a truck or trailer bed because interior carpets or plastic truck bed liners may insulate the container and slow the loss of any static charge.
- When practical, remove gas-powered equipment from the truck or trailer and refuel the equipment with its wheels on the ground.
- If this is not possible, refuel such equipment on a truck or trailer from a portable container, not from a gasoline dispenser nozzle.
- If you must use a gasoline dispenser, keep the nozzle in contact with the rim of the fuel tank or container opening at all times until fueling is complete.

Using Stabilizer/Conditioner

Use a fuel stabilizer/conditioner in the traction unit to provide the following benefits:

- It keeps gasoline fresh during storage of 90 days or less. For longer storage it is recommended that the fuel tank be drained.
- It cleans the engine while it runs
- It eliminates gum-like varnish buildup in the fuel system, which causes hard starting

Important: Do not use fuel additives containing methanol or ethanol.

Add the correct amount of gas stabilizer/conditioner to the gasoline.

Note: A fuel stabilizer/conditioner is most effective when mixed with fresh gasoline. To minimize the chance of varnish deposits in the fuel system, use a fuel stabilizer/conditioner at all times.

Filling the Fuel Tank

1. Stop the engine and wait for all moving parts to stop.
2. Clean around the fuel tank cap and remove it.
3. Add unleaded regular gasoline to the fuel tank until the level is 1/4 to 1/2 inch (6 to 13 mm) below the bottom of the filler neck. Do not fill the fuel tank completely full. **Do not fill the fuel tank completely full.**

Note: This space in the tank allows gasoline to expand.

4. Install the fuel tank cap securely.
5. Wipe up any gasoline that may have spilled.

Checking the Engine Oil Level

Before you start the engine and use the machine, check the oil level in the engine crankcase; refer to Checking the Engine Oil Level in Servicing the Engine Oil in the Maintenance section.

Using the Parking Brake

Always set the parking brake whenever you stop the machine or leave it unattended.

Setting the Parking Brake

1. Push the brake pedal (Figure 4) down and hold it.
2. Set the parking brake.

Slide the parking brake switch over (Figure 5) and gradually take your foot off the brake pedal.

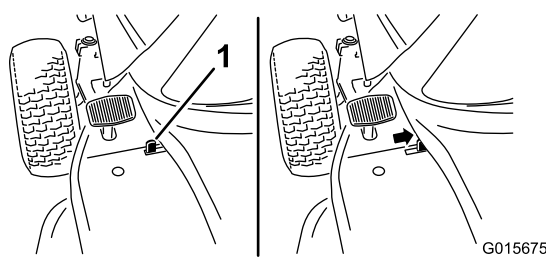

Figure 5

1. Parking brake switch

Note: The clutch/brake pedal should stay in the depressed (locked) position.

Releasing the Parking Brake

1. Push down on the brake pedal (Figure 4).

Note: The parking brake lever should release.

2. Gradually release the brake pedal.

Positioning the Seat

The seat can move forward and backward. Position the seat where you have the best control of the machine and are most comfortable.

1. Raise the seat and loosen the adjustment knobs (Figure 6).

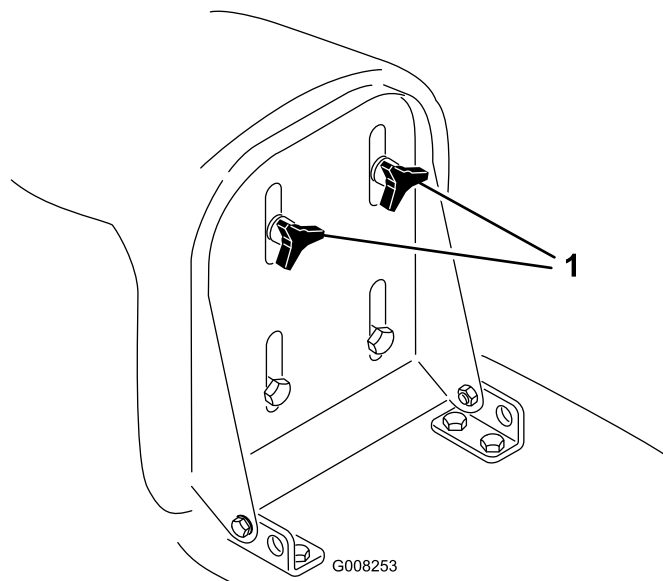

Figure 6

1. Adjustment knobs
2. Move the seat to the desired position and tighten the knobs.

Operating the Headlights

The headlights are an integral function of the ignition switch. Turn the ignition key clockwise to the Lights position.

Hour Meter

The hour meter is located on the instrument panel (Figure 4) and shows the total operating hours of the machine.

Using the Blade Control (PTO)

The blade control (PTO) knob engages and disengages power to the blades.

Engaging the Blades

1. Depress the brake pedal to stop the machine.
2. Pull the blade control (PTO) knob out to the Engaged position (Figure 4).

Disengaging the Blades

1. Depress the brake pedal to stop the machine.
2. Push the blade control (PTO) knob into the Disengaged position (Figure 4).

Setting the Height of Cut

Use the height-of-cut lever to raise and lower the mower to the desired cutting height. You can set the cutting height to 7 different positions from approximately 30 to 80 mm (1-1/4 to 3-1/8 inches).

Important: You must set the height-of-cut lever to the highest position (7) when you transport the machine off the lawn to prevent damaging the blades.

1. Push and hold in the button on the height-of-cut lever (Figure 7).

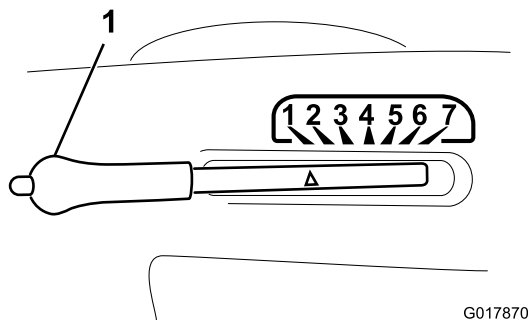

Figure 7

1. Height-of-cut lever

2. Shift the height-of-cut lever to the desired position.
3. Release the button.

Starting the Engine

1. Open the fuel shut-off valve located between the fuel tank and the engine (Figure 8).

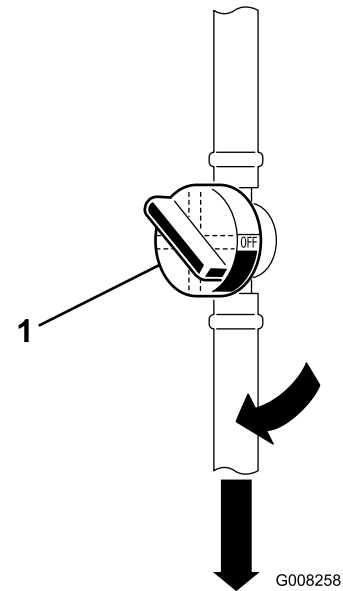

Figure 8

1. Fuel shut-off valve

Note: The valve handle should align with the fuel hose.

2. Sit down on the seat.
3. Set the parking brake; refer to Setting the Parking Brake.
4. Disengage the blades (PTO); refer to Figure 4.

Note: The engine will not start if the blades (PTO) are engaged.

5. When starting a cold engine, pull out the choke knob (Figure 9).

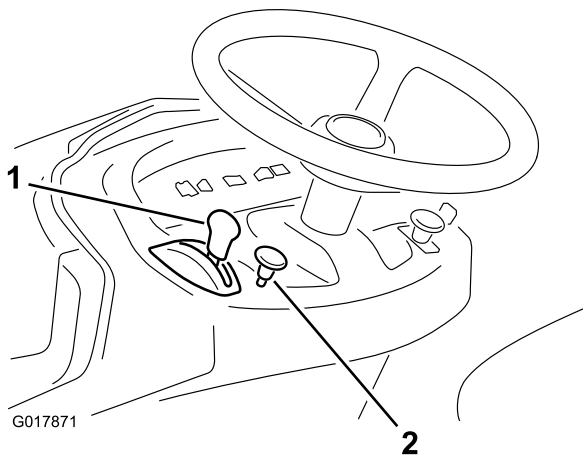

Figure 9

1. Throttle control lever
2. Choke knob

Note: To start a warm engine, push in the choke knob.

6. Turn the ignition key clockwise and hold it in the Start position (Figure 10).

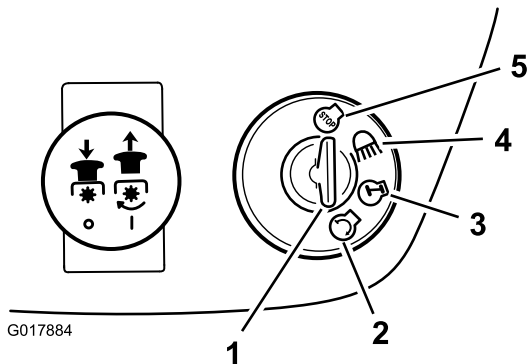

Figure 10

1. Ignition key
2. Start
3. On
4. Lights
5. Off

Note: When the engine starts, release the key.

Important: If the engine does not start after 15 seconds of continuous cranking, turn the ignition key to Off and let the starter motor cool for 2 minutes; refer to Troubleshooting.

7. After the engine starts, slowly shift the throttle control lever to the Fast position (Figure 9).

Stopping the Engine

1. Move the throttle control lever to the Slow position (Figure 9).

Note: If the engine backfires, shift the throttle control lever to the Fast position before stopping the engine.

2. Turn the ignition key to the Off position (Figure 10).

Note: If the engine has been working hard or is hot, let it idle for a minute before turning the ignition key to the Off position. This allows the engine to cool the engine before you stop it. You may stop the engine in an emergency by turning the ignition key to the Off position.

Using the Safety Interlock System

Service Interval: Before each use or daily

⚠ CAUTION

If the safety interlock switches are disconnected or damaged, the machine could operate unexpectedly, causing personal injury.

- Do not tamper with the interlock switches.
- Check the operation of the interlock switches daily and replace any damaged switches before operating the machine.
- Replace switches every 2 years regardless of whether they are operating properly or not.

Understanding the Safety Interlock System

The safety interlock system is designed to prevent the engine from starting unless:

- You are sitting on the seat.
- The brake pedal is depressed.
- The blade control (PTO) knob is in the Disengaged position.
- The traction control pedal is in the Neutral position.

The safety interlock system stops the engine if you rise from the seat and the traction control pedal is not in the Neutral position, the parking brake is not set, or the blade control (PTO) knob is in the Engaged position.

The safety interlock system is designed to stop the mower if:

- You shift into Reverse with the blades (PTO) engaged.
- You remove the bag or dump the grass.

Setting the KeyChoice® Switch to Operate in Reverse

The interlock feature on the machine prevents the power take-off (PTO) from operating when you back up the machine. If you operate the machine in reverse with the blades (PTO) engaged (i.e., with the mower blades or other attachment running), the engine will stop. **Do not mow in reverse unless it is absolutely necessary.**

If you need to use the blades (PTO) while backing up, turn off the interlock feature using the KeyChoice switch located near the seat bracket (Figure 11).

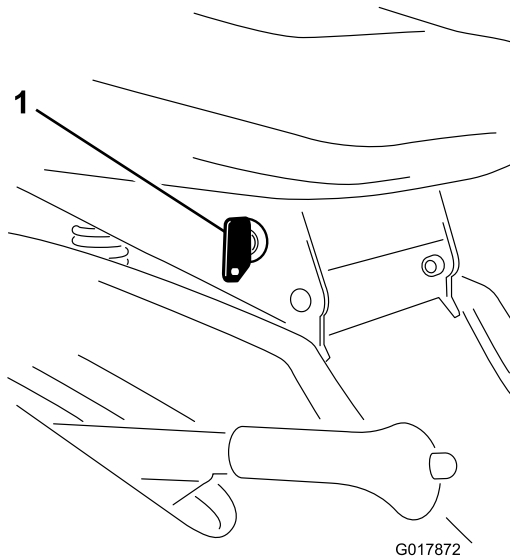

Figure 11

1. KeyChoice switch

⚠ DANGER

You could back over a child or bystander while the mower blades or other attachment is engaged and cause serious injury or death.

- **Do not mow in reverse unless it is absolutely necessary.**
- **Do not insert the KeyChoice key unless it is absolutely necessary.**
- **Always look backward and down before backing up the machine.**
- **Use the KeyChoice switch only if you are certain that no children or other bystanders will enter the mowing area.**
- **Be very observant after deactivating the interlock because the sound of the engine may prevent you from noticing that a child or bystander has entered the work area.**
- **Always remove both the ignition and KeyChoice keys and put them in a safe place out of the reach of children or unauthorized users when you leave the machine unattended.**

1. Engage the blades (PTO).
2. Insert the KeyChoice key into the switch (Figure 11).
3. Turn the KeyChoice key.

Note: The operating-in-reverse light on the front console (Figure 12) turns on, indicating that the interlock is disabled.



Figure 12

1. Operating-in-reverse light

4. Operate the machine in reverse and complete your task.
5. Disengage the blades (PTO) to activate the interlock.
6. Remove the KeyChoice key and put it in a safe place out of the reach of children.

Testing the Safety Interlock System

⚠ CAUTION

If the safety interlock switches are disconnected or damaged, the machine could operate unexpectedly, causing personal injury.

- Do not tamper with the interlock switches.
- Check the operation of the interlock switches daily and replace any damaged switches before operating the machine.

Test the safety interlock system before you use the machine each time. If the safety interlock system does not operate as described below, have an Authorized Service Dealer repair the safety interlock system immediately. While sitting in the seat, perform the following checks:

1. Set the parking brake, shift the blade control (PTO) knob to the Engage position, and turn the ignition key to Start: The engine should not crank.
2. Shift the blade control (PTO) knob to the Disengage position, release the parking brake, and turn the ignition key to Start: The engine should not crank.
3. Set the parking brake, shift the blade control (PTO) knob to Disengage, and start the engine. While the engine is running, release the parking brake and rise slightly from the seat: The engine should stop.
4. Shift the blade control (PTO) knob into the Disengage position, put the traction control pedal in the Neutral position, and start the engine. While the engine is running, shift the blade control (PTO) knob into the Engage position and put the traction control pedal in the Reverse position: The engine should stop.
5. Shift the blade control (PTO) knob into the Disengage position and put the traction control pedal in the Neutral position. Start the engine, shift the blade control (PTO) knob into the Engage position, and turn the KeyChoice key and release it: The operating-in-reverse warning light should illuminate.
6. Shift the blade control (PTO) knob to the Disengage position: The operating-in-reverse warning light should turn off.

Pushing the Machine Manually

Important: Always push the machine manually. Never tow the machine because it may damage the transaxle.

To Push the Machine

1. Park the machine on a level surface.
2. Disengage the blades (PTO).
3. Set the parking brake.
4. Stop the engine and wait for all moving parts to stop.
5. Remove the ignition key.
6. Remove the grass collector; refer to Removing the Grass Collector.
7. Pull the drive control (located at the rear of the machine), out to the Push position.
8. Release the parking brake.

Note: This disengages the drive system and allows the wheels to turn freely (Figure 13).

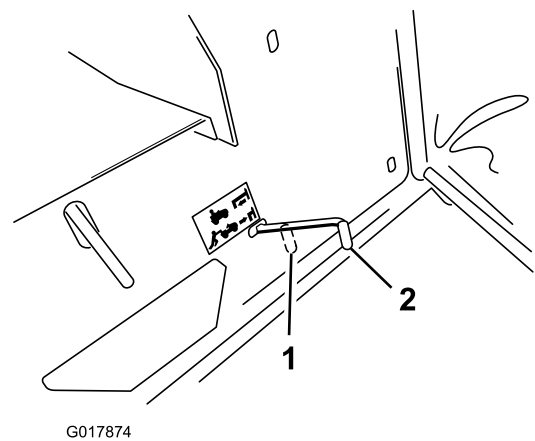

Figure 13

1. Operate position
2. Push position

To Operate the Machine

1. Set the parking brake.
2. Push the drive control into the Operate position (Figure 13) to engage the drive system.

Note: The machine will not drive unless the drive control is in the Operate position.

3. Install the grass collector; refer to Installing the Grass Collector.

Driving the Machine Forward or Backward

The throttle control regulates the engine speed as measured in RPM (revolutions per minute). Place the throttle control in the Fast position for best performance.

To go forward:

1. Release the parking brake; refer to Releasing the Parking Brake.
2. Place your foot on the forward speed pedal and slowly press on the pedal to move forward (Figure 14).

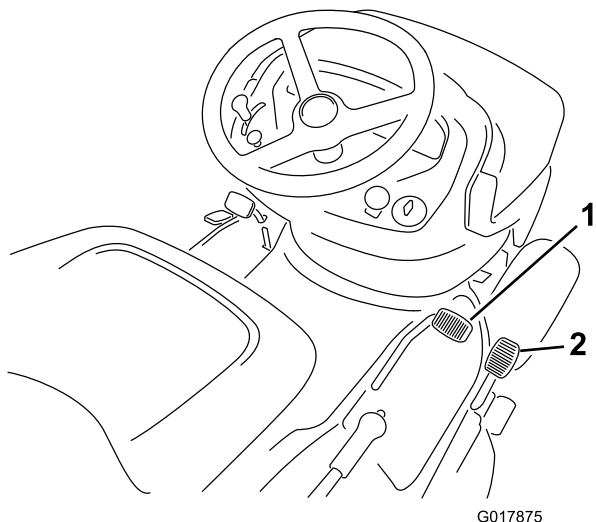

Figure 14

1. Forward speed pedal
2. Reverse speed pedal

Note: To increase the speed, push the forward speed pedal down. To decrease the speed, release the pressure on the traction control pedal.

To go backward:

1. Release the parking brake; refer to Releasing the Parking Brake.
2. Place your foot on the reverse speed pedal and slowly press on the pedal to move backward (Figure 14).

Note: To increase the speed, push the reverse speed pedal down. To decrease the speed, release the pressure on the reverse speed pedal.

Important: To avoid transmission damage, always release the parking brake before moving the traction control pedal or the reverse speed pedal.

Important: To prevent damage to the mower, always set the mower to the highest cutting position when you drive the machine off the lawn.

Stopping the Machine

1. Release the traction control pedal or reverse speed pedal.
2. Disengage the blades (PTO).

3. Turn the ignition key to the Off position.
4. Set the parking brake if you leave the machine unattended; refer to Setting the Parking Brake.

Note: Remove the keys from the ignition and KeyChoice switches.

⚠ CAUTION

Children or bystanders may be injured if they move or attempt to operate the machine while it is unattended.

Always remove the ignition and KeyChoice keys and set the parking brake when leaving the machine unattended, even if it is just for a few minutes.

Using the Recycle on Demand

You can activate or deactivate the recycle-on-demand feature while the machine is mowing or is stopped. If you are bagging grass that is tall and thick, raise the height-of-cut and mow at a slower speed.

1. Move the recycle-on-demand lever (Figure 4) forward to collect the grass clippings.
2. Move the recycle-on-demand lever rearward to stop collecting the grass clippings and recycle them.

Emptying the Grass Collector

When the grass collector is full, a buzzer sounds and the grass collector must be emptied.

Important: To prevent the discharge tunnel from getting clogged, disengage the blades (PTO) when the buzzer sounds.

1. Disengage the locking latch (Figure 15).

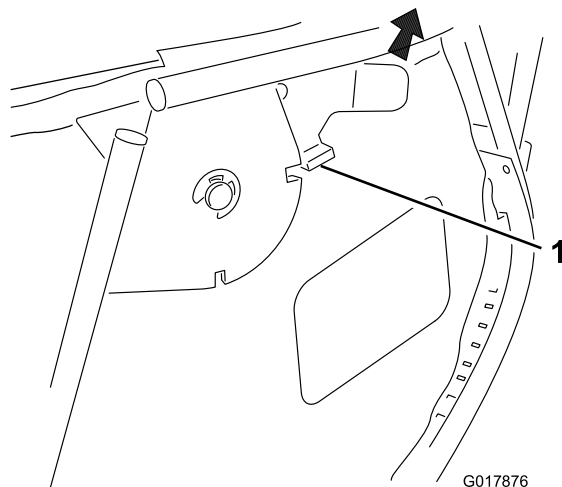

Figure 15

1. Locking latch

2. Disengage the blades (PTO) and move the throttle to the Slow position.
3. Pull the grass collector dump lever forward and tilt the grass collector (Figure 16).

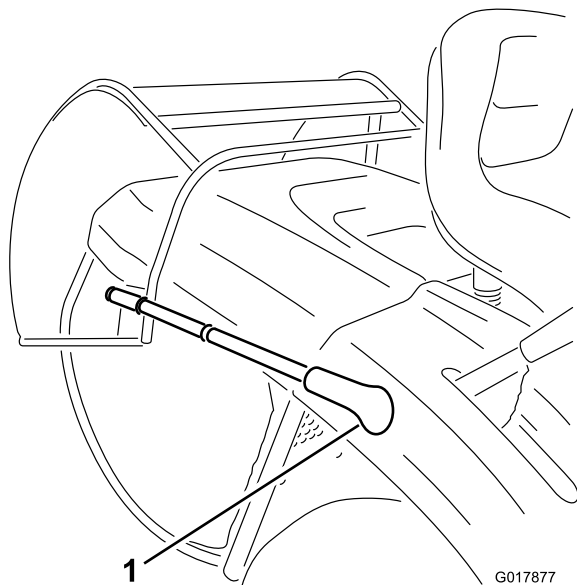

Figure 16

1. Grass collector dump lever

4. Empty the grass collector.
5. Before returning the grass collector to the operating position, move the machine forward to clear the grass collector of the deposited grass.
6. Slowly lower the telescoping dump lever to return the grass collector to the operating position.

Rear-discharging the Grass Clippings

Occasionally, you may need to cut the lawn without the grass collector when the grass is too long for collecting.

1. Disengage the locking latch (Figure 17).

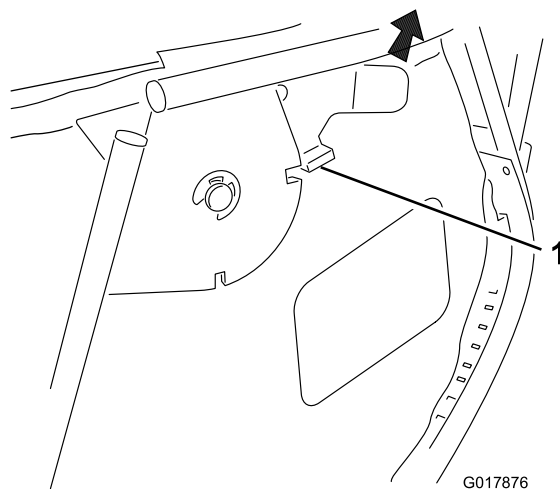

Figure 17

1. Locking latch
-
2. Disengage the blades (PTO) and move the throttle to the Slow position.
 3. Pull the grass collector dump lever forward and tilt the grass collector (Figure 18) until the locking latch engages to lock the grass collector in the open position (Figure 19).

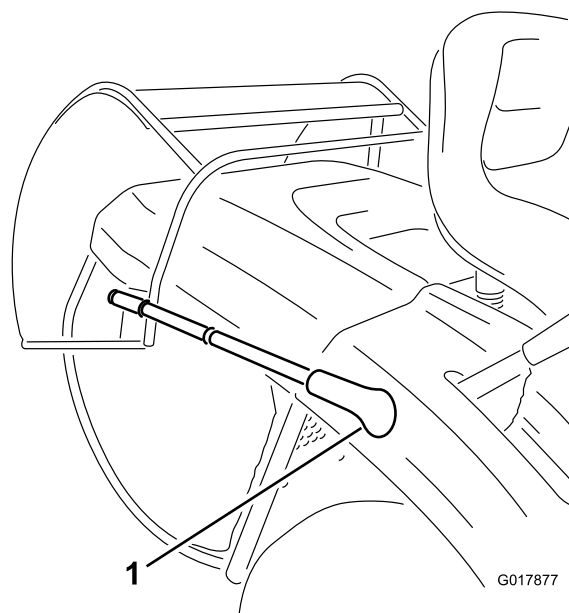

Figure 18

1. Grass collector dump lever

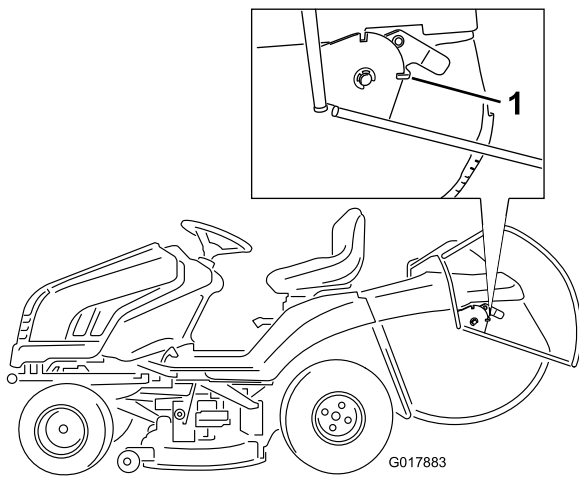

Figure 19

1. Locking latch

4. Mow the grass with the grass collector in the open position as desired.
5. Before returning the grass collector to the operating position, move the machine forward to clear the grass collector of the deposited grass.
6. Slowly lower the dump lever to return the grass collector to the operating position.

Using the Optional Towing Hitch

The machine is capable of towing non-ground-engaging attachments with a maximum weight of 150 kg (331 lb).

1. Remove the grass collector; refer to Removing the Grass Collector.
2. Install the attachment to the towing hitch located at the lower rear part of the machine (Figure 20).

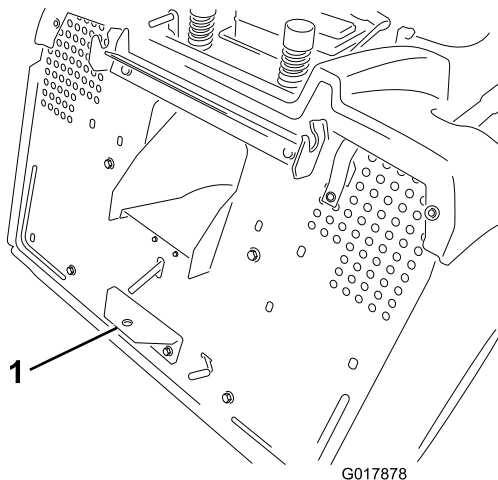

Figure 20

1. Towing hitch

Operating Tips

- For the best performance, operate the engine at the maximum speed. The mower requires air to thoroughly cut grass clippings, so do not set the height-of-cut too low or completely surround the mower in uncut grass. Always leave one side of the mower free from uncut grass to allow the air to be drawn into the mower.
- Cut the grass slightly longer than normal to ensure that the cutting height of the mower does not scalp any uneven ground. When cutting grass longer than 6 inches (15 cm) tall, cut the lawn twice to ensure an acceptable appearance.
- It is best to cut only about 1/3 of the grass blade. Do not cut more than that unless the grass is sparse or it is late fall when grass grows more slowly.
- Alternate the mowing direction to keep the grass standing straight. This also helps disperse clippings and enhances decomposition and fertilization.
- Grass grows at different rates at different times of the season. To maintain the same cutting height, which is a good practice, mow more often in early spring. As the grass growth rate slows in mid summer, mow less frequently.
- If the grass is longer than normal, or if it contains a high degree of moisture, raise the cutting height higher than usual, cut the grass at that setting, and then cut the grass again at the lower, normal setting.
- If you must stop the machine while mowing, you may leave a clump of grass clippings on your lawn. To avoid this, do the following:
 - Engage the blades and move to a previously cut area.
 - Disperse the clippings evenly by raising the mower 1 or 2 height-of-cut settings while driving forward with the blades engaged.
- Use the washout ports to clean clippings and dirt from the underside of the mower after each use. If grass and dirt build up inside the mower, the cutting quality will eventually become unsatisfactory.
- Maintain sharp blades throughout the season. Sharp blades cut grass cleanly without tearing or shredding the grass blades. Tearing and shredding the grass turns it brown at the edges, which slows its growth and increases the chance of disease. Every 30 days, check the blades for sharpness and file down any nicks.

Maintenance

Note: Determine the left and right sides of the machine from the normal operating position.

Recommended Maintenance Schedule(s)

Maintenance Service Interval	Maintenance Procedure
After the first 5 hours	<ul style="list-style-type: none">• Change the engine oil.
Before each use or daily	<ul style="list-style-type: none">• Check the safety interlock system.• Check the engine oil level.• Check the battery electrolyte level.• Check the brake.• Check the blades.• Clean the mower housing.
Every 25 hours	<ul style="list-style-type: none">• Grease and lubricate the machine. (Grease and lubricate it more frequently when operating it in dusty or sandy conditions.)• Clean and oil the air cleaner foam element.• Check the spark plug.• Check the tire pressure.• Clean the outside of the engine.
Every 50 hours	<ul style="list-style-type: none">• Change the engine oil. (Change the engine oil more frequently when operating the machine in extremely dusty or sandy conditions.)
Every 100 hours	<ul style="list-style-type: none">• Replace the air cleaner paper element. (Replace the air cleaner more frequently if the operating conditions are extremely dusty or sandy.)• Change the engine oil filter. (Change it more frequently when operating the machine in dusty or dirty conditions.)• Replace the spark plug.• Replace the fuel filter.
Yearly or before storage	<ul style="list-style-type: none">• Perform all the maintenance procedures listed above.• Drain the fuel tank.• Paint chipped surfaces.• Charge the battery and disconnect the cables.

Important: Refer to your engine operator's manual for additional maintenance procedures.

▲ CAUTION

If you leave the key in the ignition switch, someone could accidentally start the engine and seriously injure you or other bystanders.

Remove the key from the ignition and disconnect the wire from the spark plug before you do any maintenance. Set the wire aside so that it does not accidentally contact the spark plug.

Lubrication

Greasing and Lubricating the Machine

Service Interval: Every 25 hours/Yearly (whichever comes first)—Grease and lubricate the machine. (Grease and lubricate it more frequently when operating it in dusty or sandy conditions.)

How to Grease the Machine

Note: Grease the machine with a general-purpose grease.

1. Disengage the blades (PTO).
2. Set the parking brake.
3. Stop the engine and wait for all moving parts to stop.
4. Remove the ignition key.
5. Clean the grease fittings with a rag, and scrape any paint off the front of the fittings.

6. Connect a grease gun to each fitting and pump grease into it.

7. Wipe up any excess grease.

Where to Add Grease

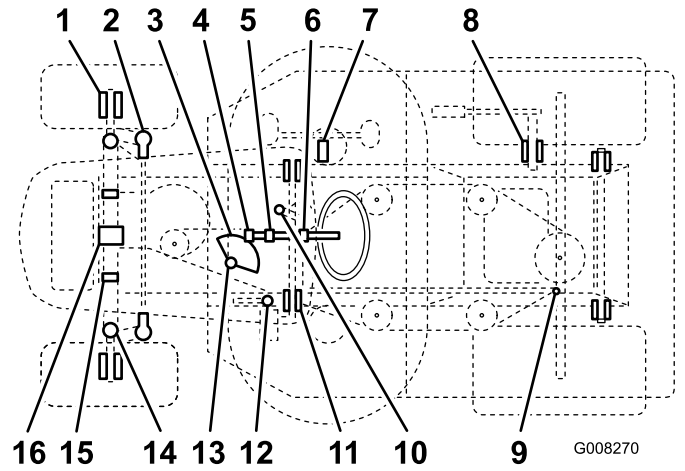

Figure 21

G008270

Grease Locations

Item	Name	Quantity (pumps)	Interval (hours)	Lubricant
1	Front wheel—grease fittings	2	25	Grease
2	Steering ball joints	4	50	Oil
3	Steering sector gear	1	50	Grease
4	Steering pinion gear	1	25	Grease
5	Steering shaft bearing	1	50	Oil
6	Steering shaft bearing	1	50	Oil
7	Motion lever	1	50	Grease
8	Shaft hub for lifting the mower housing	1	50	Oil
9	Motion link ball joints	4	50	Oil
10	Traction idler pulley belt—grease fitting	1	50	Grease
11	Brake pedal shaft pivot points	2	50	Oil
12	Parking brake ring	1	50	Oil
13	Steering bearing	1	25	Grease
14	Left and Right Spindle—grease fittings	2	25	Grease
15	Mower housing hinged pins	6	When removed	Grease
16	Front axle pivot pins	2	When removed	Grease

Engine Maintenance

Servicing the Air Cleaner

Service Interval: Every 25 hours—Clean and oil the air cleaner foam element.

Every 100 hours/Yearly (whichever comes first)—Replace the air cleaner paper element. (Replace the air cleaner more frequently if the

operating conditions are extremely dusty or sandy.)

1. Disengage the blades (PTO).
2. Set the parking brake.
3. Stop the engine and wait for all moving parts to stop.
4. Remove the ignition key.
5. Open the hood.

Removing the Foam and Paper Elements

1. Clean around the air cleaner to prevent dirt from getting into the engine and causing damage.
2. Unscrew the knobs and remove the air cleaner cover (Figure 22).

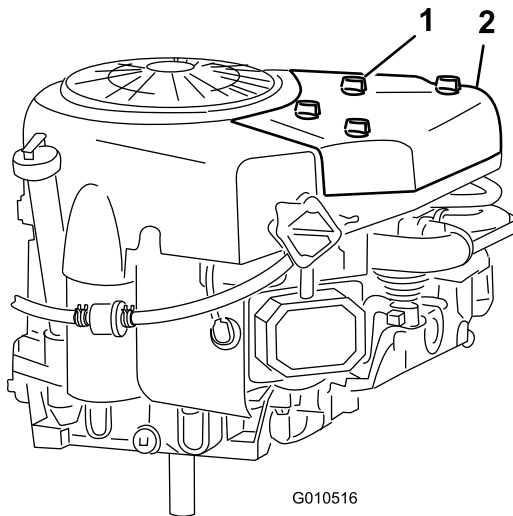

Figure 22

1. Knob (4)
2. Air cleaner cover

3. Lift out the paper cartridge and the foam element (Figure 23)

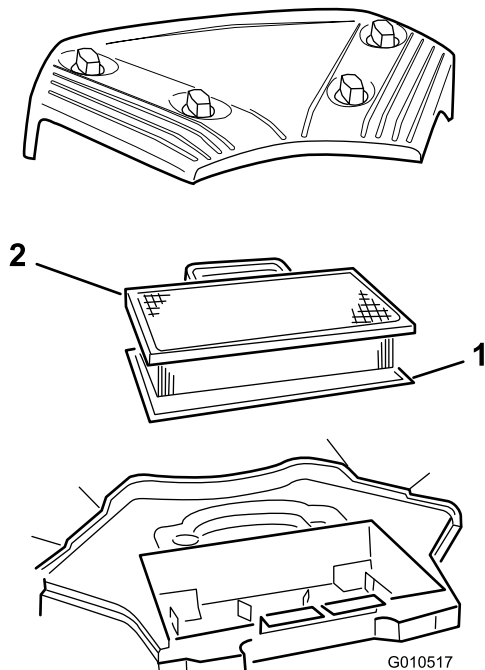

Figure 23

1. Foam element
2. Paper element

Cleaning the Foam and Paper Elements

Foam Element

1. Wash the foam element in liquid soap and warm water, and rinse it thoroughly.
2. Dry the element by squeezing it in a clean cloth.
3. Saturate the element in engine oil.
4. Squeeze the element in a clean, absorbent cloth to remove the excess oil.

Important: Replace the foam element if it is torn or worn.

Paper Element

1. Lightly tap the paper element on a flat surface to remove dust and dirt.
2. Inspect the element for tears, an oily film, and damage to the rubber seal.

Important: Never clean the paper element with pressurized air or liquids such as solvents, gasoline, or kerosene. Replace the paper element if it is damaged or cannot be cleaned thoroughly.

Installing the Foam and Paper Elements

Important: To prevent engine damage, always operate the engine with the complete foam and paper air cleaner assembly installed.

1. Install the foam element with the mesh side up.

Note: Ensure that the rubber seal is flat against the air cleaner base.

2. Position the paper element on the foam element in the air cleaner base.
3. Install the air cleaner cover and knobs (Figure 22).
4. Tighten the knobs snugly.
5. Close the hood.

Servicing the Engine Oil

Oil Type: Detergent oil (API service SF, SG, SH, SJ, or higher)

Crankcase capacity: 1.9 liters (64 oz.)

Viscosity: See the oil table (Figure 24).

USE THESE SAE VISCOSITY OILS

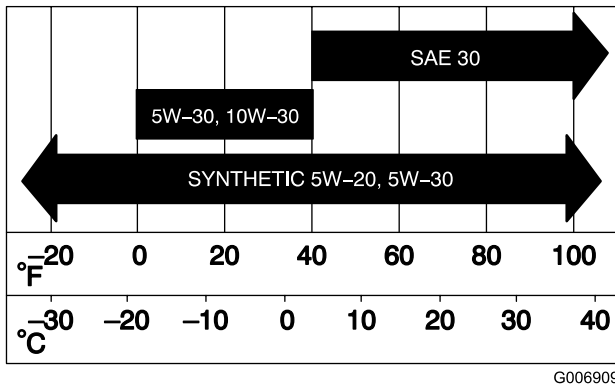

Figure 24

G006909

Checking the Engine Oil Level

Service Interval: Before each use or daily

1. Park the machine on a level surface.
2. Disengage the blades (PTO).
3. Set the parking brake.
4. Stop the engine and wait for all moving parts to stop.
5. Remove the ignition key.
6. Open the hood.
7. Clean around the dipstick (Figure 25) so that dirt cannot fall into the filler hole and damage the engine.

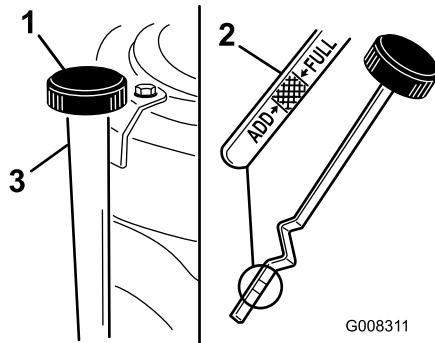

Figure 25

G008311

1. Dipstick/fill hole
2. Metal end
3. Filler tube

8. Unscrew the dipstick and wipe the metal end clean (Figure 25).
9. Screw the dipstick fully onto the filler tube (Figure 25).
10. Unscrew the dipstick again and look at the metal end. If the engine oil level is low, slowly pour only enough oil into the filler tube to raise the level to the Full mark on the dipstick.
11. Start the engine and let it idle for 30 seconds.

12. Stop the engine and wait for 30 seconds.
13. Check the oil level again and add oil if necessary.

Important: Do not overfill the crankcase with engine oil and run the engine; engine damage may result.

Changing the Engine Oil

Service Interval: After the first 5 hours

Every 50 hours (Change the engine oil more frequently when operating the machine in extremely dusty or sandy conditions.)

1. Start the engine and let it run for 5 minutes.
 - Note:** This warms the oil so that it drains better.
2. Park the machine so that the drain side is slightly lower than the other side to ensure that the oil drains completely.
3. Disengage the blades (PTO).
4. Set the parking brake.
5. Stop the engine and wait for all moving parts to stop.
6. Remove the ignition key.
7. Open the hood.
8. Place a pan below the oil drain plug.
9. Remove the oil drain plug to allow oil to drain (Figure 26).

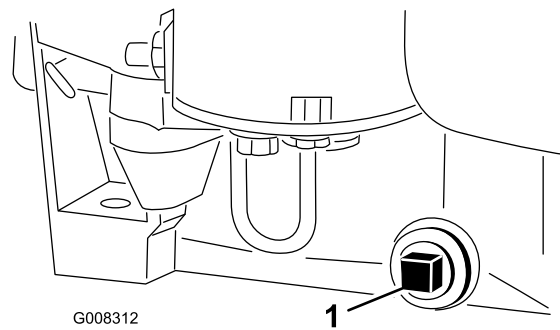

Figure 26

G008312

1. Drain plug

10. When oil has drained completely, insert the drain plug and tighten it securely.

Note: Note: Recycle the used engine oil properly.

11. Clean around the dipstick and unscrew the cap (Figure 25).
12. Slowly pour approximately 80% of the engine oil into the filler tube (Figure 25). Refer to Servicing the Engine Oil.
13. Check the engine oil level; refer to Checking the Engine Oil Level.

Changing the Engine Oil Filter

Service Interval: Every 100 hours (Change it more frequently when operating the machine in dusty or dirty conditions.)

1. Drain the oil from the engine; refer to Changing the Engine Oil.
2. Remove the old filter and wipe off the adapter gasket surface (Figure 27).

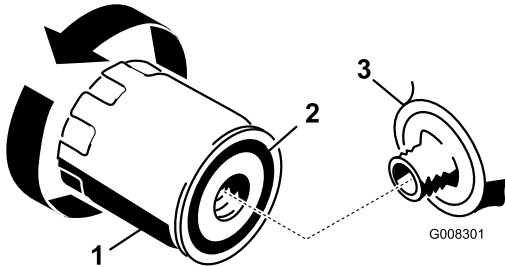

Figure 27

1. Engine oil filter
2. Gasket
3. Adapter

3. Apply a thin coat of new engine oil to the rubber gasket on the new filter (Figure 27).
4. Install the new filter to the filter adapter by turning it clockwise until the gasket contacts the filter adapter.
5. Tighten the filter an additional 1/2 to 3/4 turn (Figure 27).
6. Fill the crankcase with the proper type of new engine oil; refer to Checking the Engine Oil Level.

Servicing the Spark Plug

Service Interval: Every 25 hours—Check the spark plug.
Every 100 hours—Replace the spark plug.

Use a Champion RC12YC or equivalent spark plug. Ensure that the air gap between the center and side electrodes is 0.030 inch (0.76 mm) before installing the spark plug. Use a spark plug wrench for removing and installing the spark plug and a gapping tool or feeler gauge to check and adjust the air gap.

Removing the Spark Plug

1. Disengage the blades (PTO).
2. Set the parking brake.
3. Stop the engine and wait for all moving parts to stop.
4. Remove the ignition key.
5. Open the hood.
6. Disconnect the wire from the spark plug (Figure 28).

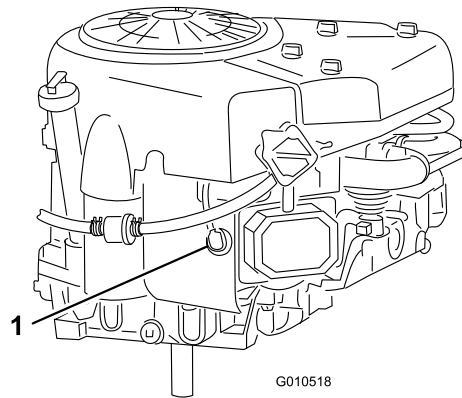

Figure 28

1. Spark plug wire

7. Clean around the spark plug to prevent dirt from falling into the engine and potentially causing damage.
8. Remove the spark plug and the metal washer (Figure 28).

Checking the Spark Plug

1. Look at the center of the spark plug (Figure 29). If you see light brown or gray on the insulator, the engine is operating properly. A black coating on the insulator usually means that the air cleaner is dirty.

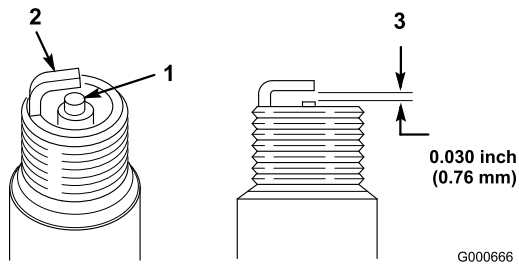

Figure 29

1. Center electrode insulator
2. Side electrode
3. Air gap (not to scale)

Important: *Do not clean the spark plug.* Always replace the spark plug when it has a black coating, worn electrodes, an oily film, or cracks.

2. Check the gap between the center and side electrodes (Figure 29) and bend the side electrode if the gap is not correct.

Installing the Spark Plug

1. Install the spark plug and metal washer. Ensure that the air gap is set correctly.
2. Tighten the spark plug to 15 ft-lb (20.4 N-m).
3. Connect the wire to the spark plug (Figure 28).
4. Close the hood.

Fuel System Maintenance

Draining the Fuel Tank

Drain the fuel tank when you will not be using the machine for more than 30 days.

⚠ DANGER

In certain conditions, gasoline is extremely flammable and highly explosive. A fire or explosion from gasoline can burn you and others and can damage property.

- Drain gasoline from the fuel tank when the engine is cold. Do this outdoors in an open area. Wipe up any gasoline that spills.
- Never smoke when draining gasoline, and stay away from an open flame or where a spark may ignite the gasoline fumes.

1. Park the machine so that the left front side is slightly lower than the right side to ensure that the fuel tank drains completely.
2. Disengage the blades (PTO).
3. Set the parking brake.
4. Stop the engine and wait for all moving parts to stop.
5. Remove the ignition key.
6. Open the hood.
7. Squeeze the ends of the hose clamp together and slide it up the fuel line toward the fuel tank (Figure 30).

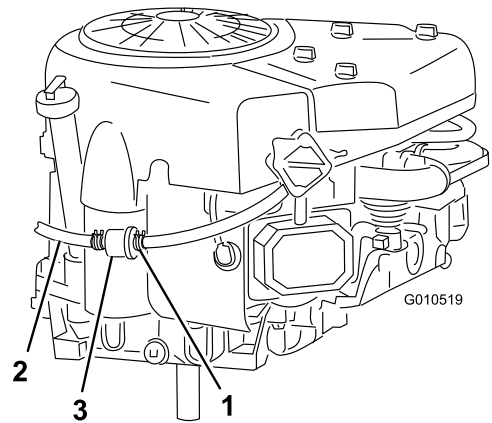

Figure 30

1. Hose clamp
2. Fuel line
3. Fuel filter

8. Pull the fuel line off the fuel filter (Figure 30) and allow the gasoline to drain into an approved fuel container or a drain pan.

Note: Now is the best time to install a new fuel filter because the fuel tank is empty.

9. Install the fuel line onto the fuel filter.
10. Slide the hose clamp close to the fuel filter to secure both the fuel line and the fuel filter (Figure 30).

Replacing the Fuel Filter

Service Interval: Every 100 hours/Yearly (whichever comes first)

The best time to replace the fuel filter (Figure 30) is when the fuel tank is empty. Never install a dirty fuel filter after it has been removed from the fuel line.

1. Disengage the blades (PTO).
2. Set the parking brake.
3. Stop the engine and wait for all moving parts to stop.
4. Remove the ignition key.
5. Close the fuel shut-off valve (Figure 31).

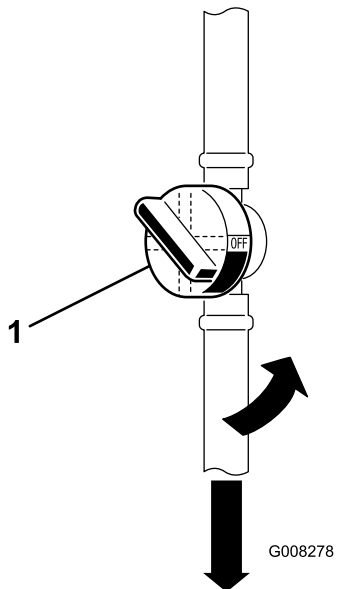

Figure 31

1. Fuel shut-off valve

6. Open the hood.
7. Squeeze the ends of the hose clamps together and slide them away from the old fuel filter (Figure 31).
8. Remove the old fuel filter from the fuel line.
9. Install a new fuel filter and move the hose clamps close to it.
10. Close the hood.

Electrical System Maintenance

Replacing the Headlight Bulbs

1. Disengage the blades (PTO).
2. Set the parking brake.
3. Stop the engine and wait for all moving parts to stop.
4. Remove the ignition key.
5. Open the hood.
6. Pull out the bulb socket (Figure 32).

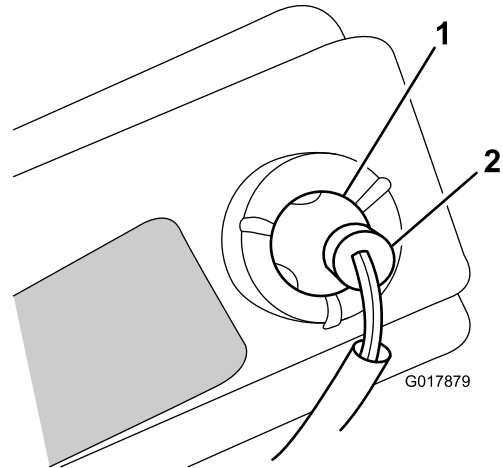

Figure 32

1. Bulb
2. Bulb socket

7. Bend the wire tabs in the metal sleeve (that hold the bulb in place) out of the way; refer to Figure 33.

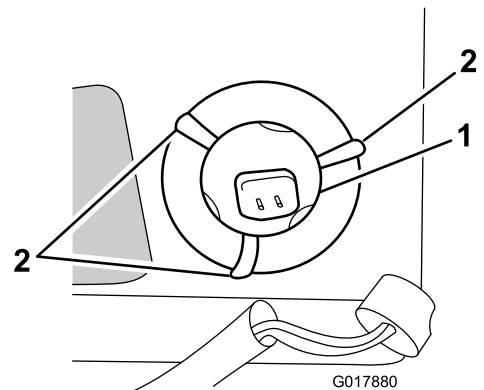

Figure 33

1. Bulb
2. Wire tabs (3)

8. Remove the old light bulb.
9. Install a new light bulb.
10. Bend the wire tabs in behind the bulb to hold it in place.
11. Install the bulb socket.

Replacing the Fuses

The electrical system is protected by fuses. They are located beneath the hood, near the fuel tank (Figure 34). If a fuse goes out, check the circuit wiring for a short.

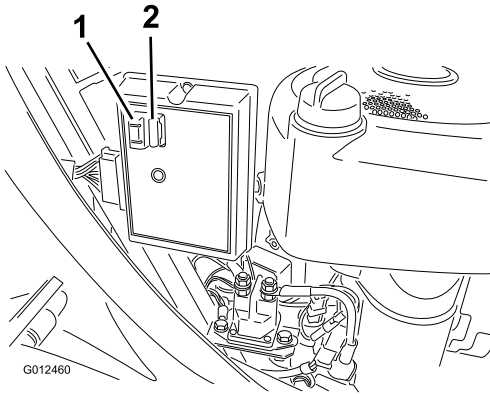

Figure 34

1. Fuses

To replace a fuse, pull up to remove the old fuse from the socket. Insert a new fuse by pushing it down into the socket.

Note: Ensure that the new fuse has the same amperage as the old fuse that you are replacing.

Servicing the Battery

Always keep the battery clean and fully charged. Use a paper towel to clean the battery and battery box. If the battery terminals are corroded, clean them with a solution of 4 parts water and 1 part baking soda. Apply a light coating of grease to the battery terminals to prevent them from corroding.

Battery voltage and amperage: 12 volts, 190 cold cranking amps

Removing the Battery

⚠ WARNING

Battery terminals or metal tools could short against metal machine components causing sparks. Sparks can cause the battery gasses to explode, resulting in personal injury.

- When removing or installing the battery, do not allow the battery terminals to touch any metal parts of the machine.
- Do not allow metal tools to short between the battery terminals and the metal parts of the machine.

1. Disengage the blades (PTO).
2. Set the parking brake.
3. Stop the engine and wait for all moving parts to stop.
4. Remove the ignition key.
5. Lift up the seat to see the battery.
6. Lift the rubber cover up off the negative (black) cable.
7. Disconnect the negative (black) ground cable from the battery post (Figure 35).

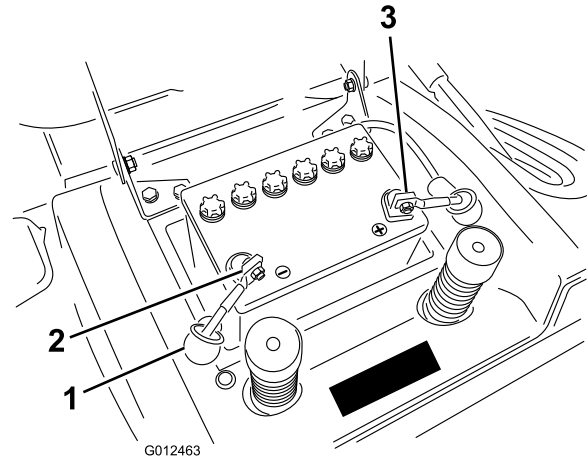

Figure 35

1. Rubber cover
2. Negative cable (black), boot not shown for clarity
3. Positive cable (red)

⚠ WARNING

Routing the battery cables improperly could damage the machine and cables, causing sparks. Sparks can cause the battery gasses to explode, resulting in personal injury.

- Always disconnect the negative (black) battery cable before disconnecting the positive (red) cable.
 - Always connect the positive (red) battery cable before connecting the negative (black) cable.
8. Lift the rubber cover up off the positive (red) cable.
 9. Disconnect the positive (red) cable from the battery post (Figure 35).
 10. Remove the battery hold down rod.
 11. Remove the battery from the chassis.

Installing the Battery

1. Place the battery into the chassis with the battery posts toward the rear of the machine (Figure 35).

2. Secure the battery in the chassis with the hold down rod.
3. Using the bolt and wing nut, connect the positive (red) cable to the positive (+) battery post (Figure 35). Slide the rubber cover over the battery post.
4. Using the bolt and wing nut, connect the negative (black) cable to the negative (-) battery post (Figure 35). Slide the rubber cover over the battery post.

Checking the Electrolyte Level

Service Interval: Before each use or daily

1. Tip the seat forward to see the battery.
2. Look at the side of the battery. The electrolyte must be up to the upper line (Figure 36).

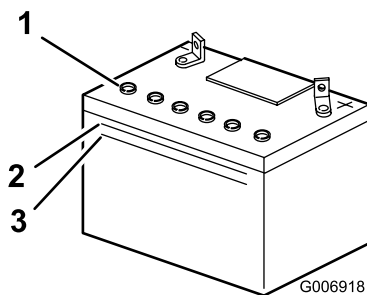

Figure 36

1. Filler caps
2. Upper line
3. Lower line

Note: do not allow the electrolyte to fall below the lower line (Figure 36).

3. If the electrolyte is low, add the required amount of distilled water; refer to Adding Water to the Battery.

⚠ DANGER

Battery electrolyte contains sulfuric acid which is a deadly poison and causes severe burns.

- Do not drink electrolyte and avoid contact with skin, eyes or clothing. Wear safety glasses to shield your eyes and rubber gloves to protect your hands.
- Fill the battery where clean water is always available for flushing the skin.

Adding Water to the Battery

The best time to add distilled water to the battery is just before you operate the machine. This lets the water mix thoroughly with the electrolyte solution.

1. Clean the top of the battery with a paper towel.

2. Remove the filler caps (Figure 36).
3. Slowly pour distilled water into each battery cell until the level is up to the lower part of the tube (Figure 36).

Important: Do not overfill the battery. Electrolyte (sulfuric acid) can severely corrode and damage the chassis.

4. Replace the filler caps.

Charging the Battery

⚠ WARNING

Charging the battery produces gasses that can explode. Never smoke near the battery and keep sparks and flames away from the battery.

Important: Always keep the battery fully charged (1.260 specific gravity), especially below 32°F (0°C) to prevent battery damage.

1. Remove the battery from the chassis; refer to Removing the Battery.
2. Check the electrolyte level; refer to Checking the Electrolyte Level.
3. Remove the filler caps from the battery and connect a 2-amp battery charger to the battery posts.
4. Charge the battery at a rate of 2 amps or less for 4 hours (12 volts). **Do not overcharge the battery.**
5. When the battery is fully charged, install the filler caps.
6. Install the battery in the chassis; refer to Installing the Battery.

Drive System Maintenance

Checking the Tire Pressure

Service Interval: Every 25 hours/Yearly (whichever comes first)

Maintain the air pressure in the front tires at 120 kPa and in the rear tires at 100 kPa. Check the pressure at the valve stem (Figure 37). Check the tires when they are cold to get the most accurate pressure reading.

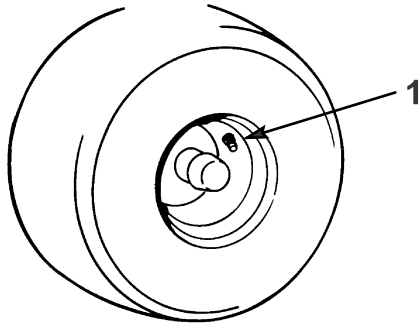

Figure 37

m-1872

1. Valve stem

Servicing the Brake

The brake is located on the right side of the rear axle, inside the rear tire (Figure 38).

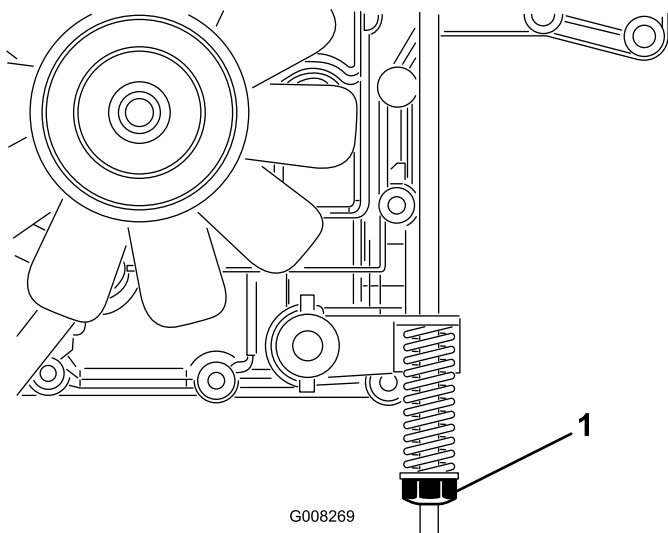

Figure 38

G008269

1. Brake adjusting nut

Checking the Brake

Service Interval: Before each use or daily

1. Park the machine on a level surface.
2. Disengage the blades (PTO).
3. Set the parking brake.
4. Stop the engine and wait for all moving parts to stop.
5. Remove the ignition key.
6. Pull the drive control out to the Push position (Figure 13).
7. If the rear wheels lock and skid when you push the machine forward, you do not need to adjust the brake. If the wheels turn and do not lock, adjust the brake; refer to Adjusting the Brake.

Adjusting the Brake

1. Check the brake before you adjust it; refer to Checking the Brake.
2. Ensure that the drive control is in the Operate position (Figure 13) and that the parking brake is on.
3. Turn the brake adjusting nut clockwise until you cannot push the machine (Figure 38).
4. Release the parking brake and ensure that the rear wheels rotate freely when you push the machine. If they do not, turn the brake adjusting nut counterclockwise just enough so that you can push the machine.
5. Check the brake operation again; refer to Checking the Brake.

Note: If the machine takes more than 1 m (3 ft.) to stop at high speed in the highest gear, adjust the brake.

Servicing the Grass Collector

Removing the Grass Collector

1. Lock the locking latch on the grass collector (Figure 39).

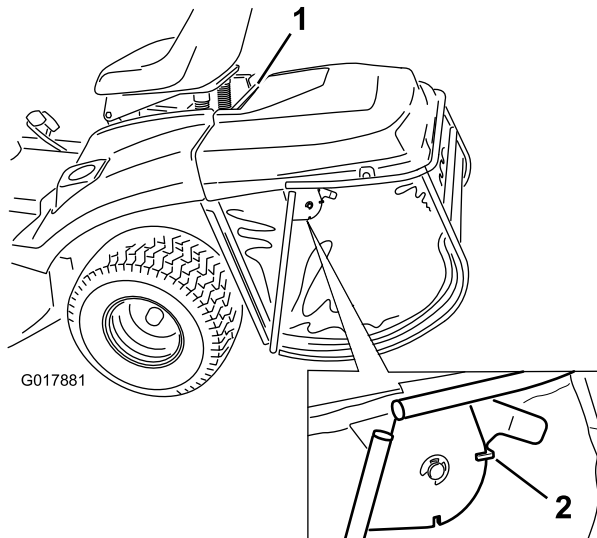

Figure 39

Cleaning the Grass Collector and Tunnel

1. Disengage the blades (PTO).
2. Set the parking brake.
3. Stop the engine and wait for all moving parts to stop.
4. Remove the ignition key.
5. Remove the grass collector; refer to Removing the Grass Collector.
6. Clean the collector bag with pressurized water.
7. Wipe the area around the full-bag sensor.
8. Clean the inside of the discharge tunnel all the way to the mower.
9. Install the grass collector; refer to Installing the Grass Collector.

Note: Allow the bag to dry thoroughly before installing it.

2. Lift up the collector using the top support bar.

Installing the Grass Collector

1. Hang the top support bar onto the 2 notches in the support bracket at the rear of the machine (Figure 40).

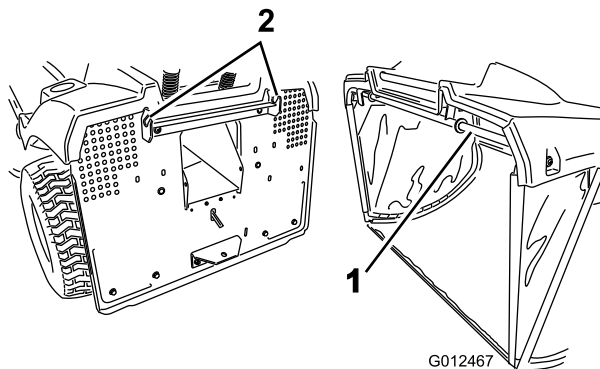

Figure 40

1. Top support bar
2. Notches in collector support bracket

Note: Ensure that the grass collector is properly seated on the mower. The mower will not function unless the grass collector is properly attached.

2. Unlock the locking pin to allow for emptying the grass collector.

Mower Deck Maintenance

Servicing the Blades

Service Interval: Before each use or daily

Note: Determine the left and right sides of the machine from the normal operating position.

To ensure a superior quality of cut, keep the blades sharp. For convenient sharpening and replacement, keep extra blades.

⚠ DANGER

Worn or damaged blades can break and a piece of the blade could be thrown into the operator's or bystander's area, resulting in serious personal injury or death.

- Inspect the blades periodically for wear or damage.
- Replace worn or damaged blades.

Inspecting the Blades

1. Remove the mower; refer to Removing the Mower.
2. Inspect the cutting edges (Figure 41). If the edges are not sharp or have nicks, remove the blades and sharpen them; refer to Sharpening the Blades.

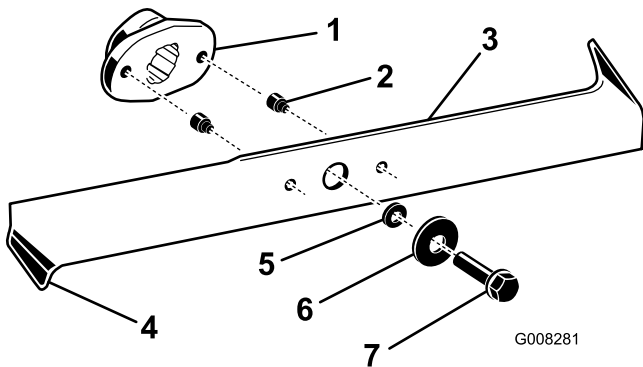

Figure 41

- | | |
|------------------|-----------|
| 1. Blade driver | 5. Spacer |
| 2. Shear pin (2) | 6. Washer |
| 3. Blade | 7. Bolt |
| 4. Bent edge | |

3. Inspect the blades, especially the bent edges (Figure 41). If you notice any wear or damage in this area, immediately install new blades.
4. If the shear pins are broken, replace them immediately (Figure 41).

Important: If the shear pins are broken, the mower belt may be damaged. Inspect the belt; refer to Adjusting the Blade Drive Belt.

Removing the Blades

1. Remove the mower; refer to Removing the Mower.
2. Carefully tip the mower over.
3. Remove the bolts, washers, and blades (Figure 41). Wedge a block of wood between each blade and the mower to lock the blade when you are removing each bolt.

Note: The right blade has a left-hand threaded bolt.

4. Inspect all parts; replace any that are worn or damaged.

Sharpening the Blades

1. Use a file to sharpen the cutting edge at both ends of each blade (Figure 42).

Note: Maintain the original angle. The blade retains its balance if you remove the same amount of material from both cutting edges.

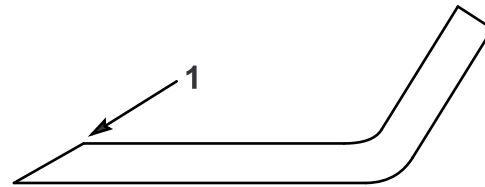

Figure 42

m-1854

1. Sharpen at original angle

2. Check the balance of each blade by putting it on a blade balancer (Figure 43).

Note: If the blade stays in a horizontal position, the blade is balanced and can be used. If the blade is not balanced, file some metal off the back side of the blade. Repeat this step until each blade is balanced.

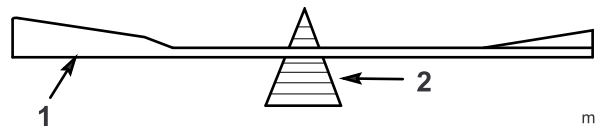

Figure 43

m-1855

1. Blade
2. Balancer

Installing the Blades

1. Install the blades, washers, and blade bolts (Figure 41).

Important: The bent edges of the blades must be pointing toward the top of the mower to ensure proper cutting.

2. Position the blades 90 degrees to each other (Figure 44).

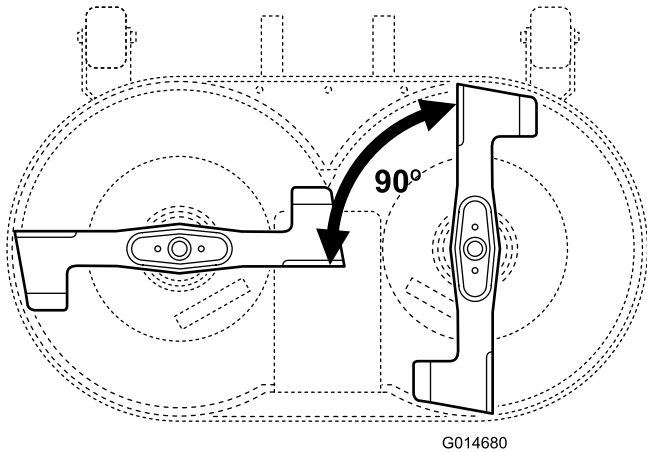

Figure 44

3. Tighten the blade bolts to 37 ft-lb (50 N-m).

Removing the Mower

1. Park the machine on a level surface.
2. Disengage the blades (PTO).
3. Set the parking brake.
4. Stop the engine and wait for all moving parts to stop.
5. Remove the ignition key.
6. Disconnect the wire from the spark plug.
7. Move the height-of-cut lever to the lowest position.
8. Remove the tunnel.
9. Pull the idler arm assembly inward and remove the V-belt from the pulley (Figure 45).

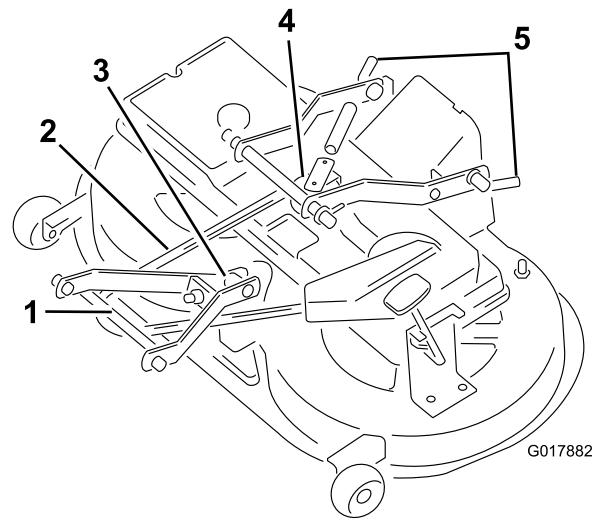

Figure 45

10. Remove both pins between the rear arm and the deck.

Important: The relief spring is very strong. Wedge the mower housing to ensure that it does not fly upward and cause damage.

11. Remove the pin between the front arm linkage and the mower housing (Figure 45).
12. Remove the V-belt from the engine pulley (Figure 45).
13. Slide the mower out from beneath the machine.

Installing the Mower

Reverse the procedure for Removing the Mower.

Storage

1. Disengage the blades (PTO).
2. Set the parking brake.
3. Stop the engine and wait for all moving parts to stop.
4. Remove the ignition key.
5. Remove the grass collector and clean it; refer to Grass Collector.
6. Remove grass clippings, dirt, and grime from the external parts of the entire machine, especially the engine. Clean the dirt and chaff from the outside of the engine cylinder head fins and blower housing.

Important: You can wash the machine with a mild detergent and water. Do not use pressurized liquids to wash the machine. Pressurized liquids may damage the electrical system or wash away necessary grease at the friction points. Avoid using water excessively, especially near the control panel, lights, engine, and battery.

7. Check the brake; refer to Checking the Brake.
8. Service the air cleaner; refer to Servicing the Air Cleaner.
9. Grease the chassis; refer to Greasing and Lubricating the Machine.
10. Change the engine oil and filter; refer to Servicing the Engine Oil.
11. Check the tire pressure; refer to Checking the Tire Pressure.
12. When storing the machine over 30 days, prepare it as follows:

- A. Add a petroleum-based stabilizer/conditioner to the fuel in the tank according to the instructions from the stabilizer manufacturer. **Do not use an alcohol-based stabilizer (ethanol or methanol).**

Note: A fuel stabilizer/conditioner is most effective when mixed with fresh gasoline and used at all times.

- B. Run the engine for 5 minutes to distribute the conditioned fuel through the fuel system.
- C. Stop the engine, allow it to cool, and drain the fuel tank; refer to Draining the Fuel Tank
- D. Start the engine and run it until it stops.
- E. Choke or prime the engine.

- F. Start and run the engine until it will not start again.

- G. Recycle the old fuel according to local codes.

- H. Close the fuel shut-off valve.

Important: Do not store stabilizer/conditioned gasoline over 90 days.

13. Remove and inspect the spark plug; refer to Servicing the Spark Plug. With the spark plug removed from the engine, pour 2 tablespoons of engine oil into the spark plug hole. Use the electric starter to crank the engine and distribute the oil inside the cylinder. Install the spark plug, but do not connect the wire to the spark plug.

14. Disconnect the negative battery cable. Clean the battery and battery terminals. Check the electrolyte level and charge it fully; refer to Servicing the Battery. Leave the negative battery cable disconnected from the battery during storage.

Important: The battery must be fully charged to prevent it from freezing and being damaged at temperatures below 32°F (0°C). You can store a fully charged battery during the winter without recharging.

15. Check and tighten all bolts, nuts, and screws. Repair or replace any part that is worn or damaged.
16. Paint all scratched or bare metal surfaces with paint available from an Authorized Service Dealer.
17. Store the machine in a clean, dry garage or storage area. Remove the ignition and KeyChoice keys from the mower and keep them in a memorable place. Cover the machine to protect it and keep it clean.

Troubleshooting

Problem	Possible Cause	Corrective Action
The starter does not crank.	<ol style="list-style-type: none"> 1. The blade control (PTO) knob is engaged. 2. The parking brake is not on. 3. The battery is dead. 4. The electrical connections are corroded or loose. 5. A fuse is blown. 6. A relay or switch is damaged. 	<ol style="list-style-type: none"> 1. Move the blade control (PTO) knob to the Disengaged position. 2. Set the parking brake. 3. Charge the battery. 4. Check the electrical connections for good contact. 5. Replace the fuse. 6. Contact an Authorized Service Dealer.
The engine overheats.	<ol style="list-style-type: none"> 1. The engine load is excessive. 2. The oil level in the crankcase is low. 3. The cooling fins and air passages under the engine blower housing are plugged. 	<ol style="list-style-type: none"> 1. Reduce the ground speed. 2. Add engine oil to the crankcase. 3. Remove the obstruction from the cooling fins and air passages.
The machine does not drive.	<ol style="list-style-type: none"> 1. The drive control is in the Push position. 2. The traction belt is worn, loose, or broken. 3. The traction belt is off the pulley. 	<ol style="list-style-type: none"> 1. Move the drive control to the Operate position. 2. Contact an Authorized Service Dealer. 3. Contact an Authorized Service Dealer.
The engine will not start, starts hard, or fails to keep running.	<ol style="list-style-type: none"> 1. The operator is not seated. 2. The fuel tank is empty. 3. The air cleaner is dirty. 4. The spark plug wire is loose or disconnected. 5. A spark plug is pitted, fouled, or the gap is incorrect. 6. The choke is not closing. 7. There is dirt in the fuel filter 8. The idle speed is too low or the mixture is incorrect. 9. Dirt, water, or stale fuel is in the fuel system. 10. The fuel shut-off valve is closed. 	<ol style="list-style-type: none"> 1. Sit on the seat. 2. Fill the fuel tank with gasoline. 3. Clean or replace the air cleaner element. 4. Install the wire on the spark plug. 5. Install a new, correctly-gapped spark plug. 6. Adjust the throttle cable. 7. Replace the fuel filter. 8. Contact an Authorized Service Dealer. 9. Contact an Authorized Service Dealer. 10. Open the fuel shut-off valve.
The engine loses power.	<ol style="list-style-type: none"> 1. The engine load is excessive. 2. The air cleaner is dirty. 3. The oil level in the crankcase is low. 4. The cooling fins and air passages under the engine blower housing are plugged. 5. The spark plug is pitted, fouled, or the gap is incorrect. 6. The vent hole in the fuel cap is plugged. 7. There is dirt in the fuel filter. 8. Dirt, water, or stale fuel is in the fuel system. 	<ol style="list-style-type: none"> 1. Reduce your ground speed. 2. Clean the air cleaner element. 3. Add engine oil to the crankcase. 4. Remove the obstruction from the cooling fins and air passages. 5. Install a new, correctly-gapped spark plug. 6. Clean or replace the fuel cap. 7. Replace the fuel filter. 8. Contact an Authorized Service Dealer.

Problem	Possible Cause	Corrective Action
There is abnormal vibration.	<ol style="list-style-type: none"> 1. The blades are bent or unbalanced. 2. The blade mounting screws are loose. 3. The engine mounting bolts are loose. 4. There is a loose engine pulley, idler pulley, or blade pulley. 5. The engine pulley is damaged. 6. The blade drive belt is damaged. 	<ol style="list-style-type: none"> 1. Install a new blades. 2. Tighten the blade mounting screws. 3. Tighten the engine mounting bolts. 4. Tighten the appropriate pulley. 5. Contact an Authorized Service Dealer. 6. Contact an Authorized Service Dealer.
The blades do not rotate.	<ol style="list-style-type: none"> 1. The grass collector is not in place. 2. The blade drive belt is worn, loose, or broken. 3. The blade drive belt is off the pulley. 	<ol style="list-style-type: none"> 1. Install the grass collector. 2. Contact an Authorized Service Dealer. 3. Contact an Authorized Service Dealer.
The cutting height is uneven.	<ol style="list-style-type: none"> 1. The tire pressure is incorrect. 2. The mower is not level. 3. The underside of the mower is dirty. 4. The blade mounting screws are loose. 5. The blade drive belt tension is incorrect. 	<ol style="list-style-type: none"> 1. Set the tire pressure. 2. Adjust the height adjustment cable rod assembly. 3. Clean the underside of the mower. 4. Tighten the blade mounting screws. 5. Contact an Authorized Service Dealer.

Notes:

Notes:

Notes:

Intl Dist List

Distributor:	Country:	Phone Number:
Atlantis Su ve Sulama Sisstemleri Lt	Turkey	90 216 344 86 74
Balama Prima Engineering Equip.	Hong Kong	852 2155 2163
B-Ray Corporation	Korea	82 32 551 2076
Casco Sales Company	Puerto Rico	787 788 8383
Ceres S.A.	Costa Rica	506 239 1138
CSSC Turf Equipment (pvt) Ltd.	Sri Lanka	94 11 2746100
Cyril Johnston & Co.	Northern Ireland	44 2890 813 121
Equiver	Mexico	52 55 539 95444
Femco S.A.	Guatemala	502 442 3277
G.Y.K. Company Ltd.	Japan	81 726 325 861
Geomechaniki of Athens	Greece	30 10 935 0054
Guandong Golden Star	China	86 20 876 51338
Hako Ground and Garden	Sweden	46 35 10 0000
Hako Ground and Garden	Norway	47 22 90 7760
Hayter Limited (U.K.)	United Kingdom	44 1279 723 444
Hydroturf Int. Co Dubai	United Arab Emirates	97 14 347 9479
Hydroturf Egypt LLC	Egypt	202 519 4308
Ibea S.P.A.	Italy	39 0331 853611
Irriamc	Portugal	351 21 238 8260
Irrigation Products Int'l Pvt Ltd.	India	86 22 83960789
Jean Heybroek b.v.	Netherlands	31 30 639 4611
Maquiver S.A.	Colombia	57 1 236 4079
Maruyama Mfg. Co. Inc.	Japan	81 3 3252 2285
Metra Kft	Hungary	36 1 326 3880
Mountfield a.s.	Czech Republic	420 255 704 220
Munditol S.A.	Argentina	54 11 4 821 9999
Oslinger Turf Equipment SA	Ecuador	593 4 239 6970
Oy Hako Ground and Garden Ab	Finland	358 987 00733
Parkland Products Ltd.	New Zealand	64 3 34 93760
Prochaska & Cie	Austria	43 1 278 5100
RT Cohen 2004 Ltd.	Israel	972 986 17979
Riversa	Spain	34 9 52 83 7500
Sc Svend Carlsen A/S	Denmark	45 66 109 200
Solvvert S.A.S.	France	33 1 30 81 77 00
Spypros Stavrinides Limited	Cyprus	357 22 434131
Surge Systems India Limited	India	91 1 292299901
T-Markt Logistics Ltd.	Hungary	36 26 525 500
Toro Australia	Australia	61 3 9580 7355
Toro Europe NV	Belgium	32 14 562 960



The Toro Warranty

Conditions and Products Covered

The Toro Company and its affiliate, Toro Warranty Company, pursuant to an agreement between them, jointly promise to the original purchaser* to repair the Toro Products listed below if defective in materials or workmanship.

The following time periods apply from the date of purchase:

Products	Warranty Period
Walk Power Mowers	
• Cast Deck	5 years Residential Use ² 45 Days Commercial Use
• Engine	5 years GTS Promise See engine manufacturer's warranty ¹
• Steel Deck	2 years Residential Use ² 45 Days Commercial Use
• Engine	2 years GTS Promise See engine manufacturer's warranty ¹
Electric Hand Held Products	2 year limited warranty
Snowthrowers	
• Single Stage	2 years Residential Use ² 45 Days Commercial Use
• Two Stage	2 years Residential Use ² 45 Days Commercial Use
• Electric	2 years Residential Use ²
All Ride-On Units Below	
• Engine	See engine manufacturer's warranty ¹ 1 year Parts only
• Attachments	1 year
Rear Engine Riders	2 years Residential Use ² 90 Days Commercial Use
Lawn & Garden Tractors	2 years Residential Use ² 90 Days Commercial Use
TimeCutter Z Mowers	3 years Residential Use ² 30 Days Commercial Use
TITAN Mowers	3 years or 240 hours ³
• Frame	Lifetime (original owner only) ⁴
TITAN MX Mowers	3 years or 400 hours ³
• Frame	Lifetime (original owner only) ⁴
Z Master Mowers — 2000 Series	5 years or 1200 hours ³
• Frame	Lifetime (original owner only) ⁴

*Original Purchaser means the person who originally purchased the Toro Product.

¹Some engines used on Toro Products are warranted by the engine manufacturer.

²Residential use means use of the product on the same lot as your home. Use at more than one location is considered commercial use and the commercial use warranty would apply.

³Whichever occurs first.

⁴Lifetime Frame Warranty - If the main frame, consisting of the parts welded together to form the tractor structure that other components such as the engine are secured to, cracks or breaks in normal use, it will be repaired or replaced, at Toro's option, under warranty at no cost for parts and labor. Frame failure due to misuse or abuse and failure or repair required due to rust or corrosion are not covered.

This warranty includes the cost of parts and labor, but you must pay transportation costs.

Warranty may be denied if the hour meter is disconnected, altered, or shows signs of being tampered with.

Owner Responsibilities

You must maintain your Toro Product by following the maintenance procedures described in the *Operator's Manual*. Such routine maintenance, whether performed by a dealer or by you, is at your expense.

Instructions for Obtaining Warranty Service

If you think that your Toro Product contains a defect in materials or workmanship, follow this procedure:

1. Contact your seller to arrange service of the product. If for any reason it is impossible for you to contact your seller, you may contact any Toro Authorized Distributor to arrange service.
2. Bring the product and your proof of purchase (sales receipt) to the Service Dealer. If for any reason you are dissatisfied with the Service Dealer's analysis or with the assistance provided, contact us at:

Customer Care Department, RLC Division
 The Toro Company
 8111 Lyndale Avenue South
 Bloomington, MN 55420-1196
 Manager: Technical Product Support: 001-952-887-8248

See attached Distributor List

Items and Conditions Not Covered

This express warranty does not cover the following:

- Cost of regular maintenance service or wear parts, such as blades, rotor blades (paddles), scraper blades, belts, fuel, lubricants, oil changes, spark plugs, cable/linkage or brake adjustments
- Any product or part which has been altered or misused and requires replacement or repair due to accidents or lack of proper maintenance
- Repairs necessary due to failure to use fresh fuel (less than one month old), or failure to properly prepare the unit prior to any period of non-use over one month
- Engine and transmission. These are covered by the appropriate manufacturer's guarantees with separate terms and conditions

All repairs covered by these warranties must be performed by an Authorized Toro Service Dealer using Toro approved replacement parts.

General Conditions

The purchaser is covered by the national laws of each country. The rights to which the purchaser is entitled with the support of these laws are not restricted by this warranty.