



Count on it.

Operator's Manual

Workman® MDX-D Utility Vehicle

Model No. 07359—Serial No. 312000001 and Up

Model No. 07359TC—Serial No. 312000001 and Up

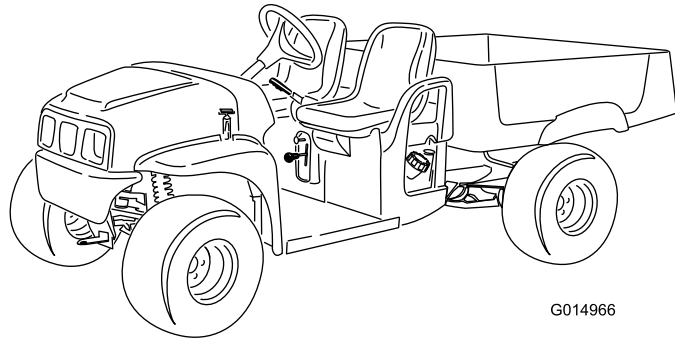

G014966



This machine is a utility vehicle intended to be used by professional, hired operators in commercial applications. It is primarily designed for the transport of implements used in such applications. This vehicle allows for the safe transport of an operator and one passenger in the identified seats. The bed of this vehicle is not suitable for any riders.

This product complies with all relevant European directives, for details please see the separate product specific Declaration of Conformity (DOC) sheet.

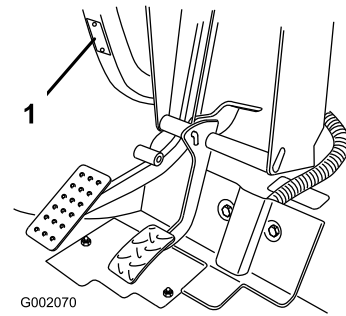

Figure 1

1. Model and serial number location

WARNING

CALIFORNIA Proposition 65 Warning

The engine exhaust from this product contains chemicals known to the State of California to cause cancer, birth defects, or other reproductive harm.

Important: This engine is not equipped with a spark arrester muffler. It is a violation of California Public Resource Code Section 4442 to use or operate the engine on any forest-covered, brush-covered, or grass-covered land. Other states or federal areas may have similar laws.

The enclosed *Engine Owner's Manual* is supplied for information regarding the US Environmental Protection Agency (EPA) and the California Emission Control Regulation of emission systems, maintenance, and warranty. Replacements may be ordered through the engine manufacturer.

Introduction

Read this information carefully to learn how to operate and maintain your product properly and to avoid injury and product damage. You are responsible for operating the product properly and safely.

You may contact Toro directly at www.Toro.com for product and accessory information, help finding a dealer, or to register your product.

Whenever you need service, genuine Toro parts, or additional information, contact an Authorized Service Dealer or Toro Customer Service and have the model and serial numbers of your product ready. [Figure 1](#) identifies the location of the model and serial numbers on the product. Write the numbers in the space provided.

Model No. _____
Serial No. _____

This manual identifies potential hazards and has safety messages identified by the safety alert symbol ([Figure 2](#)), which signals a hazard that may cause serious injury or death if you do not follow the recommended precautions.



Figure 2

1. Safety alert symbol

This manual uses 2 other words to highlight information. **Important** calls attention to special mechanical information and **Note** emphasizes general information worthy of special attention.

Contents

Safety	4	Drive System Maintenance	28
Safe Operating Practices	4	Checking and Adjusting Neutral	28
Supervisor's Responsibilities	4	Inspecting the Tires	29
Before Operating	4	Adjusting Front Wheel Toe-In and Camber	29
Operation	5	Inspecting the Primary Drive Clutch	30
Maintenance	6	Maintaining the Primary Drive Clutch	31
Sound Power	6	Changing the Transaxle Fluid	31
Sound Pressure	6	Cooling System Maintenance	32
Hand-Arm Vibration	6	Cleaning the Engine Cooling Areas	32
Whole Body Vibration	6	Filling the Radiator	32
Safety and Instructional Decals	7	Brake Maintenance	33
Setup	10	Inspecting the Brakes	33
1 Installing the Steering Wheel	10	Checking the Brake Fluid Level	33
2 Reading the Manual and Viewing the Safety		Adjusting the Parking Brake	33
Training Material	10	Belt Maintenance	34
Product Overview	12	Servicing the Drive Belt	34
Controls	12	Checking the Belt Pull Bumper	34
Specifications	14	Cleaning	35
Attachments/Accessories	14	Washing the Vehicle	35
Operation	15	Storage	35
Think Safety First	15	Schematics	36
Pre-Starting Checks	15		
Checking the Engine Oil	15		
Checking the Brake Fluid Level	15		
Checking the Tire Pressure	15		
Adding Fuel	16		
Checking the Transmission Oil Level	17		
Starting the Engine	17		
Stopping the Vehicle	17		
Parking the Vehicle	17		
Operating the Cargo Box	17		
Breaking in a New Vehicle	18		
Loading the Cargo Box	18		
Transporting the Vehicle	19		
Towing the Vehicle	19		
Towing a Trailer	19		
Maintenance	20		
Recommended Maintenance Schedule(s)	20		
Daily Maintenance Checklist	21		
Pre-maintenance Procedures	22		
Maintaining the Vehicle under Special Operating			
Conditions	22		
Jacking the Vehicle	22		
Accessing the Hood	22		
Lubrication	23		
Adding Grease	23		
Engine Maintenance	23		
Servicing the Air Cleaner	23		
Servicing the Engine Oil	24		
Fuel System Maintenance	25		
Inspecting Fuel Lines and Connections	25		
Replacing the Fuel Filter	25		
Electrical System Maintenance	25		
Replacing the Fuses	25		
Replacing the Headlights	25		
Servicing the Battery	26		

Safety

Improper use or maintenance by the operator or owner can result in injury. To reduce the potential for injury, comply with these safety instructions and always pay attention to the safety alert symbol, which means **Caution**, **Warning**, or **Danger**—“personal safety instruction.” Failure to comply with the instruction may result in personal injury or death.

The machine meets the requirements of SAE J2258.

Supervisors, operators, and service persons should be familiar with the following standards and publications (the material may be obtained from the address shown):

- Flammable and Combustible Liquids Code: ANSI/NFPA 30
- National Fire Protection Association:
ANSI/NFPA #505; Powered Industrial Trucks, National Fire Prevention Association, Barrymarch Park, Quincy, Massachusetts 02269 U.S.A.
- ANSI/ASME B56.8 Personal Burden Carriers
American National Standards Institute, Inc., 1430 Broadway, New York, New York 10018 U.S.A.
- SAE J2258 Light Utility Vehicle
SAE International, 400 Commonwealth Drive, Warrendale, PA 15096-0001 U.S.A.
- ANSI/UL 558; Internal Combustion Engine Powered Industrial Trucks
American National Standards Institute, Inc., 1430 Broadway, New York, New York 10018 U.S.A.
or
Underwriters Laboratories, 333 Pfingsten Road, Northbrook, Illinois 60062 U.S.A.

Safe Operating Practices

▲ WARNING

The Workman is an off-highway vehicle only, and is not designed, equipped, or manufactured for use on public streets, roads or highways.

The Workman was designed and tested to offer safe service when operated and maintained properly. Although hazard control and accident prevention partially are dependent upon the design and configuration of the machine, these factors are also dependent upon the awareness, concern, and proper training of the personnel involved in the operation, maintenance and storage of the machine. Improper use or maintenance of the machine can result in injury or death.

This is a specialized utility vehicle designed for off-road use only. Its ride and handling will have a different feel than what drivers experience with passenger cars or trucks. So take time to become familiar with your Workman.

Not all of the attachments that adapt to the Workman are covered in this manual. See the specific *Operator's Manual* provided with each attachment for additional safety instructions. **Read these manuals.**

To reduce the potential for injury or death, comply with the following safety instructions:

Supervisor's Responsibilities

- Make sure operators are thoroughly trained and familiar with the *Operator's Manual* and all labels on the vehicle.
- Be sure to establish your own special procedures and work rules for unusual operating conditions (e.g. slopes too steep for vehicle operation).

Before Operating

- Operate the machine only after reading and understanding the contents of this manual. A replacement manual is available by sending complete model and serial number to: The Toro Company, 8111 Lyndale Avenue South, Minneapolis, Minnesota 55420.
- **Never** allow children to operate the vehicle. **Never** allow adults to operate it without proper instructions. Only trained and authorized persons should operate this vehicle. Make sure all operators are physically and mentally capable of operating the vehicle.
- This vehicle is designed to carry **only you**, the operator, and **one passenger** in the seat provided by the manufacturer. **Never** carry any other passengers on the vehicle.
- **Never** operate the vehicle when under the influence of drugs or alcohol.
- Become familiar with the controls and know how to stop the engine quickly.
- Keep all shields, safety devices and decals in place. If a shield, safety device or decal is malfunctioning, illegible, or damaged, repair or replace it before operating the machine.
- Always wear substantial shoes. Do not operate the machine while wearing sandals, tennis shoes, or sneakers. Do not wear loose fitting clothing or jewelry which could get caught in moving parts and cause personal injury.
- Wearing safety glasses, safety shoes, long pants, and a helmet is advisable and required by some local safety and insurance regulations.
- Keep everyone, especially children and pets, away from the areas of operation.
- Before operating the vehicle, always check all parts of the vehicle and any attachments. If something is wrong, **stop using vehicle**. Make sure the problem is corrected before vehicle or attachment is operated again.
- Since diesel fuel is highly flammable, handle it carefully.

- Use an approved fuel container.
- Do not remove the cap from the fuel tank when the engine is hot or running.
- Do not smoke while handling fuel.
- Fill the fuel tank outdoors and to about one inch below the top of tank (bottom of filler neck). **Do not overfill.**
- Wipe up any spilled fuel.
- Operate the vehicle only outdoors or in a well ventilated area.
- Use only an approved nonmetal, portable fuel container. Static electric discharge can ignite fuel vapors in a ungrounded fuel container. Remove the fuel container from the bed of the vehicle and place it on the ground away from the vehicle before filling. Keep the nozzle in contact with the container while filling. Remove equipment from vehicle bed before filling.
- Check the safety interlock system daily for proper operation. If a switch should malfunction, replace the switch before operating machine.

Operation

- The operator should keep both hands on the steering wheel, whenever possible, and the passenger should use the hand holds provided. Keep arms and legs within the vehicle body at all times. Never carry passengers in the box or on attachments. Remember your passenger may not be expecting you to brake or turn and may not be ready.
- Never overload your vehicle. The name plate (located under the middle of the dash) shows the load limits for the vehicle. Never overfill attachments or exceed the vehicle maximum gross vehicle weight (GVW).
- When starting the engine:
 - Sit on operator’s seat and ensure that the parking brake is engaged.
 - Keep your foot on the brake.
 - Turn ignition switch to the On position. When the glow plug indicator goes off, the engine is ready to start.
 - Turn the ignition key to the Start position.
- Using the machine demands attention. Failure to operate vehicle safely may result in an accident, tip over of the vehicle, and serious injury or death. Drive carefully. To prevent tipping or loss of control, take the following precautions:
 - Use extreme caution, reduce speed, and maintain a safe distance around sand traps, ditches, creeks, ramps, any unfamiliar areas, or other hazards.
 - Watch for holes or other hidden hazards.
 - Use caution when operating the vehicle on a steep slope. Normally, travel straight up and down slopes. Reduce speed when making sharp turns or when turning on hillsides. Avoid turning on hillsides whenever possible.
- Use extra caution when operating the vehicle on wet surfaces, at higher speeds, or with a full load. Stopping time will increase with a full load. Shift into a lower gear before starting up or down a hill.
- When loading the bed, distribute the load evenly. Use extra caution if the load exceeds the dimensions of the vehicle/bed. Operate the vehicle with extra caution when handling off-center loads that cannot be centered. Keep loads balanced and secure to prevent them from shifting.
- Avoid sudden stops and starts. Do not go from reverse to forward or forward to reverse without first coming to a complete stop.
- Do not attempt sharp turns or abrupt maneuvers or other unsafe driving actions that may cause a loss of vehicle control.
- Do not pass another vehicle traveling in the same direction at intersections, blind spots, or at other dangerous locations.
- When dumping, do not let anyone stand behind vehicle and do not dump the load on any one’s feet. Release the tailgate latch from the side of box, not from behind.
- Keep all bystanders away. Before backing up, look to the rear and ensure that no one is behind the vehicle. Back up slowly.
- Watch out for traffic when near or crossing roads. Always yield the right of way to pedestrians and other vehicles. This vehicle is not designed for use on streets or highways. Always signal your turns or stop early enough so other persons know what you plan to do. Obey all traffic rules and regulations.
- Never operate the vehicle in or near an area where there is dust or fumes in the air which are explosive. The electrical and exhaust systems of the vehicle can produce sparks capable of igniting explosive materials.
- Always watch out for and avoid low overhangs such as tree limbs, door jambs, over head walkways, etc. Make sure there is enough room over head to easily clear the vehicle and your head.
- If ever unsure about safe operation, **stop work** and ask your supervisor.
- Do not touch engine, transaxle, radiator, muffler or muffler manifold while engine is running or soon after it has stopped because these areas may be hot enough to cause burns.
- If the machine ever vibrates abnormally, stop immediately, turn engine off, wait for all motion to stop and inspect for damage. Repair all damage before resuming operation.
- Before getting off the seat:
 - Stop movement of the machine.
 - Shut engine off and wait for all movement to stop.

- Set parking brake.
- Remove key from ignition.
- Lightning can cause severe injury or death. If lightning is seen or thunder is heard in the area, do not operate the machine; seek shelter.

Maintenance

- Before servicing or making adjustments to the machine, stop the engine, set the parking brake, and remove the key from ignition to prevent accidental starting of the engine.
- Never work under a raised bed without placing the bed on the fully extended prop rod.
- To make sure the entire machine is in good condition, keep all nuts, bolts, and screws properly tightened.
- To reduce the potential fire hazard, keep the engine area free of excessive grease, grass, leaves, and accumulation of dirt.
- If the engine must be running to perform a maintenance adjustment, keep hands, feet, clothing, and any parts of the body away from the engine and any moving parts. Keep everyone away.
- Do not overspeed the engine by changing the governor settings. The maximum engine speed is 3470 RPM. To ensure safety and accuracy, have an Authorized Toro Distributor check the maximum engine speed with a tachometer.
- If major repairs are ever needed or assistance is required, contact an Authorized Toro Distributor.
- To be sure of optimum performance and safety, always purchase genuine Toro replacement parts and accessories. Replacement parts and accessories made by other manufacturers could be dangerous. Altering this vehicle in any manner may affect the vehicle's operation, performance, durability or its use may result in injury or death. Such use could void the product warranty of The Toro® Company.
- This vehicle should not be modified without The Toro® Company's authorization. Direct any inquiries to The Toro® Company, Commercial Division, Vehicle Engineering Dept., 8111 Lyndale Ave. So., Bloomington, Minnesota 55420–1196. USA

Sound Power

This unit has a guaranteed sound power level of 98 dBA, which includes an Uncertainty Value (K) of 1 dBA.

Sound power level was determined according to the procedures outlined in EN ISO 11094.

Sound Pressure

This unit has a sound pressure level at the operator's ear of 85 dBA, which includes an Uncertainty Value (K) of 1 dBA.

Sound pressure level was determined according to the procedures outlined in EN ISO 11201.

Hand-Arm Vibration

Measured vibration level for right hand = 1.25 m/s²

Measured vibration level for left hand = 1.36 m/s²

Uncertainty Value (K) = 0.68 m/s²

Measured values were determined according to the procedures outlined in EN 1032.

Whole Body Vibration

Measured vibration level = 0.35 m/s²

Uncertainty Value (K) = 0.17 m/s²

Measured values were determined according to the procedures outlined in EN 1032.

Safety and Instructional Decals



Safety decals and instructions are easily visible to the operator and are located near any area of potential danger. Replace any decal that is damaged or lost.



104-6581

1. Warning—read the *Operator's Manual*.
2. Fire hazard—before fueling, stop the engine.
3. Warning—do not operate this machine unless you are trained.
4. Tipping hazard—use caution and drive slowly while on slopes; drive slowly when turning, keep the vehicle speed under 16 MPH (26 km/h) when carrying a full or heavy load and when driving on rough terrain.
5. Falling and arm/leg injury hazards—do not carry passengers in the cargo bed and keep arms and legs inside of the vehicle at all times.

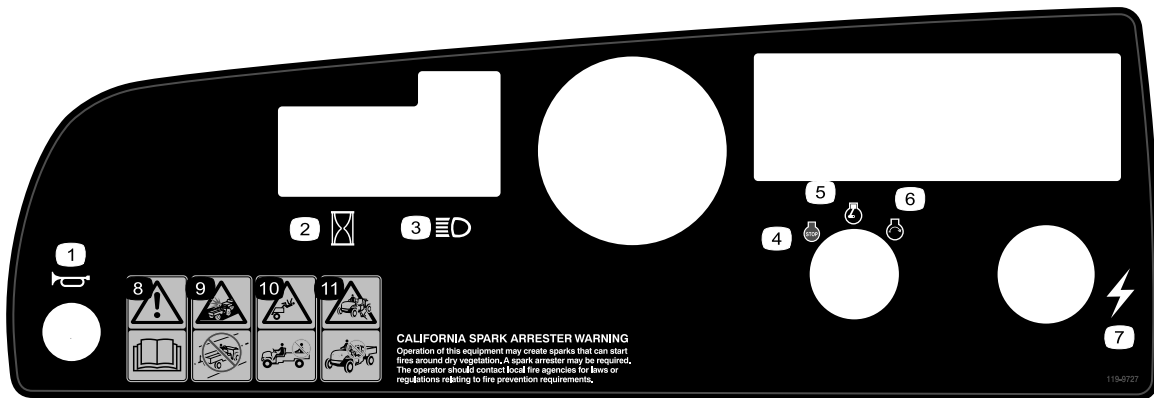

119-9727

- | | |
|--|--|
| <ol style="list-style-type: none"> 1. Horn 2. Hour meter 3. Headlights 4. Engine—stop 5. Engine—on 6. Engine—start | <ol style="list-style-type: none"> 7. Power point 8. Warning—read the <i>Operator's Manual</i>. 9. Collision hazard—do not operate the vehicle on public streets, roads, or highways. 10. Falling hazard—do not carry passengers in the cargo bed. 11. Falling hazard—do not allow children to operate the vehicle. |
|--|--|

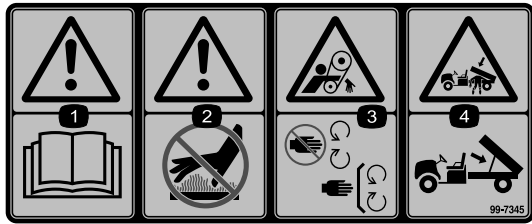

99-7345

1. Warning—read the *Operator's Manual*.
2. Hot surface/burn hazard—stay a safe distance from the hot surface.
3. Entanglement hazard, belt—stay away from moving parts; keep all guards in place.
4. Crushing hazard, cargo box—use the prop rod to support the cargo bed

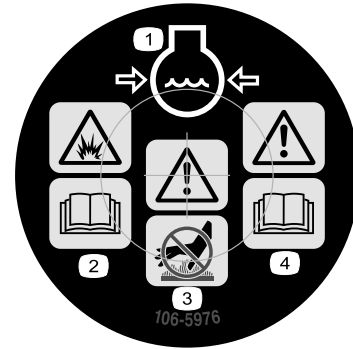

106-5976

1. Engine coolant under pressure
2. Explosion hazard—read the *Operator's Manual*.
3. Warning—do not touch the hot surface.
4. Warning—read the *Operator's Manual*.

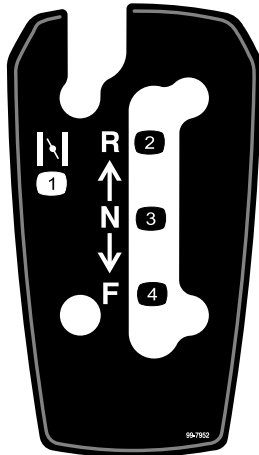

99-7952

1. Choke
2. Reverse
3. Neutral
4. Forward

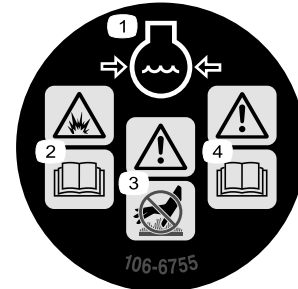

106-6755

1. Engine coolant under pressure.
2. Explosion hazard—read the *Operator's Manual*.
3. Warning—do not touch the hot surface.
4. Warning—read the *Operator's Manual*.

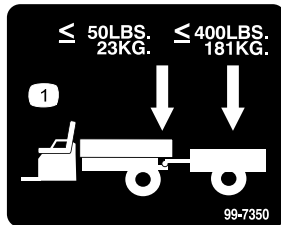

99-7350

1. Maximum tongue weight is 50 lb (23 kg); maximum trailer weight is 400 lb (181 kg).

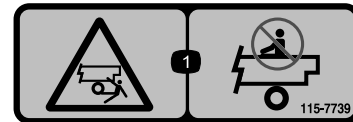

115-7739

1. Falling, crushing hazard, bystanders—no riders on machine.



117-4955

1. Warning—read the *Operator's Manual*; wear the seat belt when seated in the operator's position; avoid tipping the machine.
2. Warning—wear hearing protection.

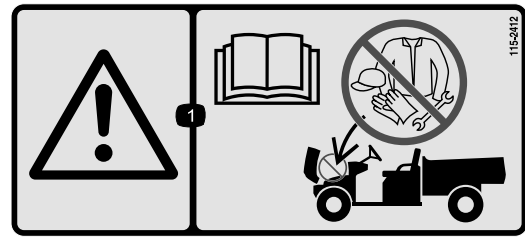

115-2412

1. Warning—read the *Operator's Manual*; no storage.

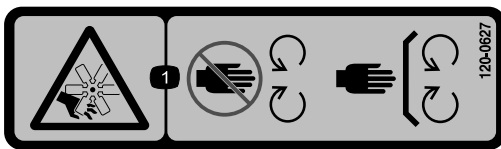

120-0627

1. Cutting/dismemberment hazard, fan—stay away from moving parts, keep all guards and shields in place.

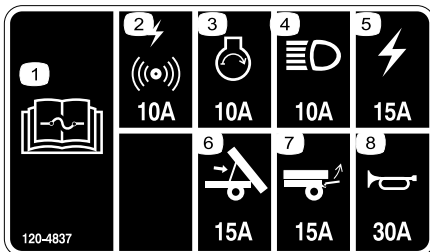

120-4837

- | | |
|--|----------------------|
| 1. Read the <i>Operator's Manual</i> for information on fuses. | 5. Machine fuse, 15A |
| 2. Alarm/power point, 10A | 6. Lift, 15A |
| 3. Engine, 10A | 7. Rear lift, 15A |
| 4. Headlights, 10A | 8. Horn, 30A |

Setup

Loose Parts

Use the chart below to verify that all parts have been shipped.

Procedure	Description	Qty.	Use
1	Steering wheel	1	Install the steering wheel (Model 07359TC only).
2	Operator's Manual Engine Operator's Manual Parts Catalog Safety Training material Registration Card Predelivery Inspection Form Certificate of Quality Key	1 1 1 1 1 1 1 2	Read the Operator's Manual and view the training material before operating the machine.

Note: Determine the left and right sides of the machine from the normal operating position.

1

Installing the Steering Wheel

Parts needed for this procedure:

1	Steering wheel
---	----------------

Procedure

Note: This procedure is only needed for Model No. 07359TC.

1. Release the tabs on the back of the steering wheel that hold the center cover in place. Remove the cover.
2. Remove the nut and washer from the steering shaft.
3. Slide the steering wheel and washer onto the shaft. Position the steering wheel on the shaft so that the cross beam is horizontal when the tires are pointed straight ahead and the thicker spoke of the steering wheel is downward.
4. Secure the steering wheel to the shaft with the nut (Figure 3). Torque the nut to 18-22 ft-lb (24-29 N-m).

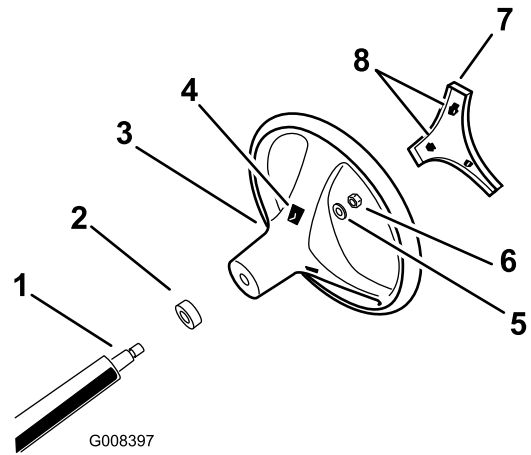

Figure 3

- | | |
|-----------------------|------------------|
| 1. Steering shaft | 5. Washer |
| 2. Foam seal | 6. Nut |
| 3. Steering wheel | 7. Cover |
| 4. Tab slots in wheel | 8. Tabs in cover |
-
5. Snap the center cover in place.

2

Reading the Manual and Viewing the Safety Training Material

Parts needed for this procedure:

1	<i>Operator's Manual</i>
1	<i>Engine Operator's Manual</i>
1	<i>Parts Catalog</i>
1	Safety Training material
1	Registration Card
1	<i>Predelivery Inspection Form</i>
1	Certificate of Quality
2	Key

Procedure

- Read the *Operator's Manual* and *Engine Operator's Manual*.
- View the safety training material.
- Fill out the registration card.
- Complete the *Predelivery Inspection Form*.
- Review the *Certificate of Quality*.

Product Overview

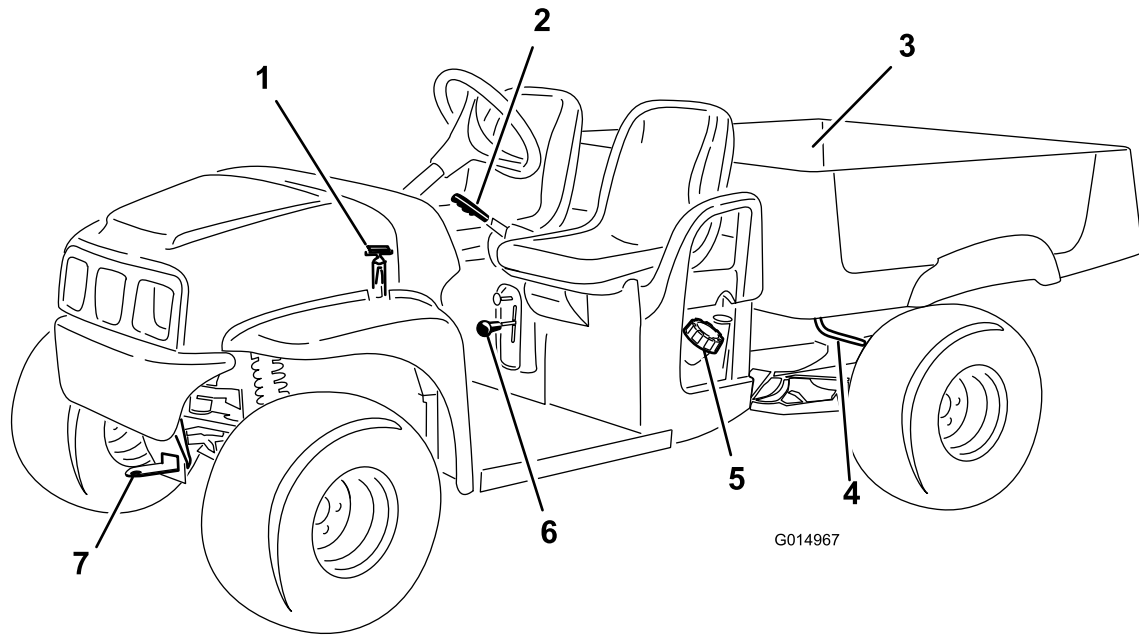

G014967

Figure 4

- | | | | |
|------------------|----------------------------|------------------------|------------------|
| 1. Hood strap | 3. Cargo box | 5. Fuel cap | 7. Towing tongue |
| 2. Parking brake | 4. Cargo box release lever | 6. Gear shift selector | |

Controls

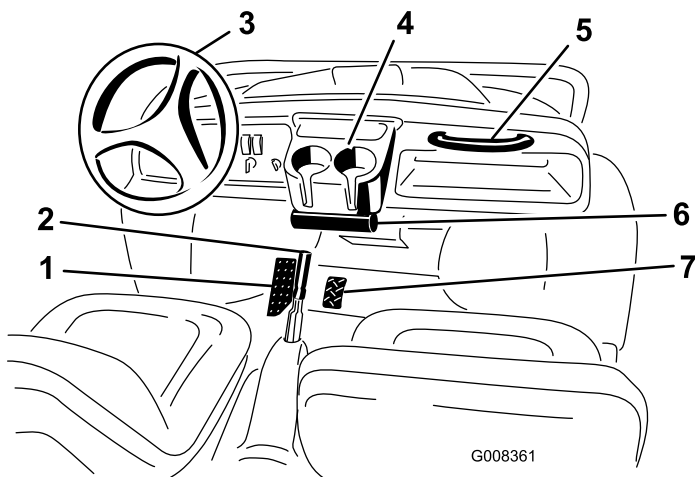

G008361

Figure 5

- | | |
|----------------------------------|-----------------------------------|
| 1. Brake pedal | 5. Passenger hand hold |
| 2. Parking brake, center console | 6. Operator's Manual tube console |
| 3. Steering wheel | 7. Accelerator pedal |
| 4. Cup holder | |

increases ground speed. Releasing the pedal will slow the vehicle. Maximum forward speed is 16 MPH (26 km/h).

Brake Pedal

The brake pedal is used to stop or slow the vehicle (Figure 5).

⚠ CAUTION

Brakes can become worn or can be incorrectly adjusted resulting in personal injury.

If brake pedal travels to within 1 inch (25 mm) of the vehicle floor board, the brakes must be adjusted or repaired.

Parking Brake

The parking brake is between the seats (Figure 5). Whenever the engine is shut off, the parking brake must be engaged to prevent accidental movement of the vehicle. To engage the parking brake, pull back on the lever. To disengage, push the lever forward. If the vehicle is parked on a steep grade, make sure that the parking brake is applied.

Accelerator Pedal

The accelerator pedal (Figure 5) gives the operator the ability to vary ground speed of the vehicle. Pressing the pedal

Gear Shift Selector

The gear shift selector has three positions: forward, reverse, and neutral. The engine will start and run in any of the three positions.

Important: Always stop the vehicle before changing gears.

Ignition Switch

The ignition switch (Figure 6), used to start and stop the engine, has 3 positions: Off, On, and Start. Rotate the key clockwise to the Start position to activate the glow plugs. When the Glow Plug Indicator light turns off, rotate the key counterclockwise to the On position. To shut off the engine, rotate the key counterclockwise to the Off position. Remove the key from the ignition when leaving the vehicle.

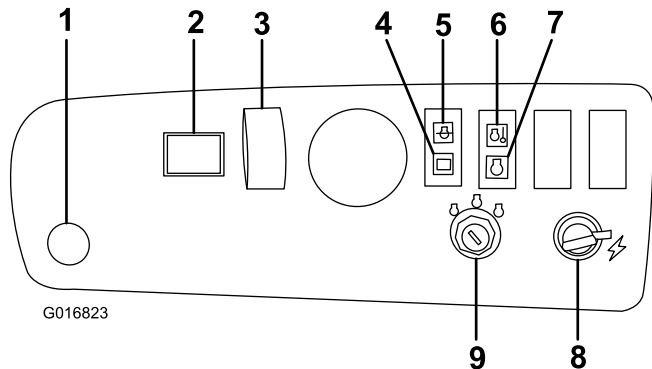

Figure 6

- | | |
|---------------------------------|-----------------------------|
| 1. Horn Button (TC Models Only) | 6. Engine temperature light |
| 2. Hour meter | 7. Glow plug Indicator |
| 3. Light switch | 8. Power point |
| 4. Battery light | 9. Ignition switch |
| 5. Oil light | |

Hour Meter

The hour meter (Figure 6) indicates the total number of hours the engine has run. The hour meter starts to function whenever the key switch is rotated to the On position or if the engine is running.

Battery Light

The battery light (Figure 6) turns on for several seconds when the engine is first started. If the light remains on while the engine is running, the alternator, battery, or electrical system is damaged.

Oil Light

The oil light warns the operator if the engine oil level drops below a safe level (Figure 6). If the light comes on and remains lit, the oil level should be checked and oil added if necessary; refer to Checking the Engine Oil in Operation.

Note: The oil light may flicker. This is normal and no action needs to be taken.

Engine Temperature Light

If the engine temperature light is on, the engine is overheating (Figure 6). Stop the engine and allow the unit to cool down. Check the coolant level and the belts to the fan and water pump. Fill the coolant as required and replace any worn or slipping belts. If the problem persists, contact your Authorized Toro Dealer for diagnostics and repair.

Glow Plug Indicator

Glow plug indicator (Figure 6) will glow red when the glow plugs are activated.

Light Switch

Toggle the switch to activate the headlights. Push to turn the lights on (Figure 6).

Power Point

Use the power point to power 12 volt optional electrical accessories (Figure 6).

Horn Button (TC Model Only)

Press the horn button to sound the horn (Figure 6).

Fuel Gauge

The fuel gauge (Figure 7) is on the fuel tank next to the filler cap on the operator's side of the vehicle. The gauge displays the amount of fuel in the tank.

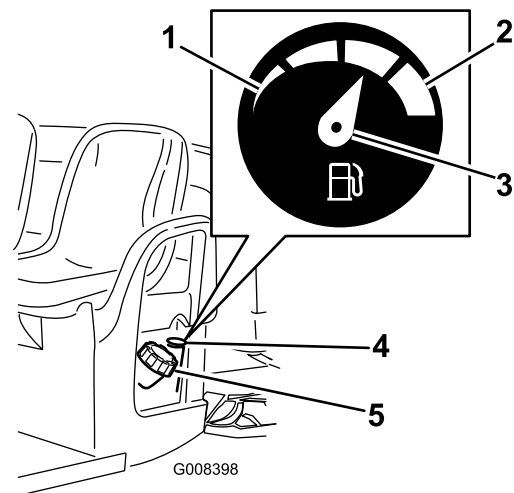

Figure 7

- | | |
|-----------|------------------|
| 1. Empty | 4. Fuel gauge |
| 2. Full | 5. Fuel tank cap |
| 3. Needle | |

Passenger Hand Holds

The passenger hand holds are located on the right side of the dash panel and at the outside of each seat (Figure 8).

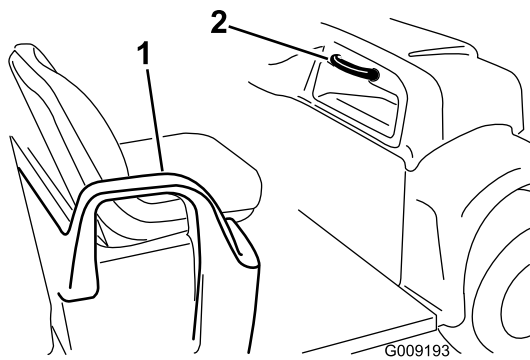

Figure 8

1. Hip restraint 2. Passenger hand hold

Specifications

Note: Specifications and design are subject to change without notice.

Base weight	Dry 1300 lb (590 kg)
Rated capacity (on level ground)	1650 lb (749 kg) total, including 200 lb (90.7 kg) operator and 200 lb (90.7 kg) passenger, load, trailer tongue weight, gross trailer weight, accessories, and attachments
Maximum gross vehicle weight (GVW) (on level ground)	2950 lb (1341 kg) total, including all of the weights listed above
Maximum cargo capacity (on level ground)	1250 lb (567 kg) total, including trailer tongue weight and gross trailer weight
Tow capacity:	
Standard Hitch	Tongue weight 50 lb (23 kg) Maximum trailer weight 400 lb (182 kg)
Heavy Duty Hitch	Tongue weight 100 lb (45 kg) Maximum trailer weight 800 lb (363 kg)
Overall width	59 inches (150 cm)
Overall length	117.75 inches (299 cm)
Ground clearance	10 inches (25.4 cm) at the front with no load or operator, 7 inches (18 cm) at the rear with no load or operator
Wheel base	81 inches (205.7 cm)
Wheel tread (center line to center line)	49 inches (124.5 cm) in the front, 47-1/4 inches (120 cm) in the rear
Cargo box length	46 inches (116.8 cm) inside, 52-1/4 inches (132.7 cm) outside
Cargo box width	49 inches (124.5 cm) inside, 59 inches (150 cm) at outside of the molded fenders
Cargo box height	10 inches (25.4 cm) inside
Maximum speed	16 MPH (26 km/h)
Engine RPM (non-adjustable)	Low idle –1250 ±50 RPM, High idle –3470 ±50 RPM

Attachments/Accessories

A selection of Toro approved attachments and accessories is available for use with the machine to enhance and expand its capabilities. Contact your Authorized Service Dealer or Distributor or go to www.Toro.com for a list of all approved attachments and accessories.

Operation

Note: Determine the left and right sides of the machine from the normal operating position.

Think Safety First

Please carefully read all of the safety instructions and decals in the safety section. Knowing this information could help you or bystanders avoid injury.

Pre-Starting Checks

Check the following items each time you begin using the vehicle for the day:

- Check the tire pressure.

Note: These tires are different than car tires; they require less pressure to minimize turf compaction and damage.

- Check all fluid levels and add the appropriate amount of specified fluids, if any are found to be low.
- Check the brake pedal operation.
- Ensure that the lights are working.
- Turn the steering wheel to the left and right to check steering response.
- Check for oil leaks, loose parts, and any other noticeable malfunctions. Make sure the engine is off and all moving parts have stopped before checking for oil leaks, loose parts, and other malfunctions.

If any of the above items are not correct, notify your mechanic or check with your supervisor before taking the vehicle out for the day. Your supervisor may want you to check other items on a daily basis, so ask what your responsibilities are.

Checking the Engine Oil

Service Interval: Before each use or daily

Note: The engine is shipped with oil in the crankcase; however, the level of the oil must be checked before and after the engine is first started.

Check the engine oil level before starting the engine each day.

1. Position the machine on a level surface.
2. Clean around the oil dipstick ([Figure 9](#)) so dirt cannot fall into the hole and damage the engine.

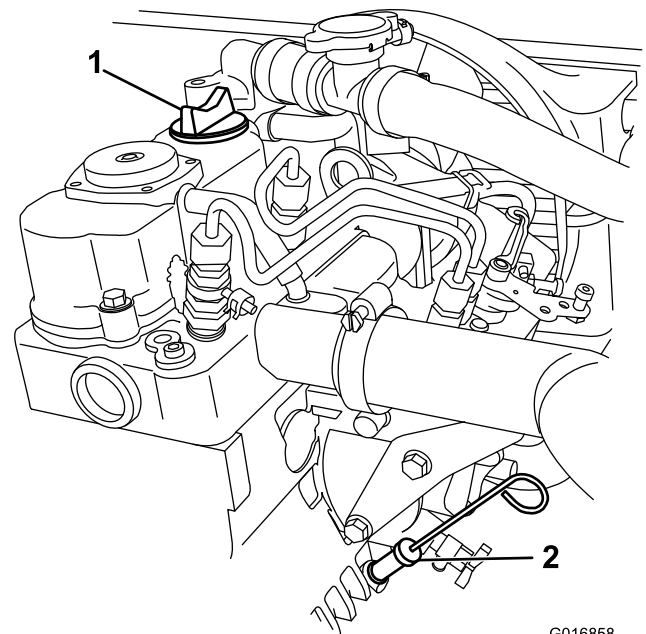

G016858

Figure 9

1. Fill cap
2. Oil dipstick

3. Remove the oil dipstick and wipe the end clean.
4. Slide the oil dipstick into the filler tube fully seating it. Pull the dipstick out and look at the end.

If the oil level is low, remove the filler cap and add oil of the proper type to raise the level to, but not over, the Full mark on the dipstick. Refer to Servicing the Engine Oil in the Engine Maintenance section in Maintenance, for the proper oil type and viscosity. Add the oil slowly and check the level often during this process. **Do not overfill.**
5. Install the oil dipstick firmly in place.

Checking the Brake Fluid Level

Check the brake fluid level before the engine is first started; refer to Checking the Brake Fluid Level in the Brake Maintenance section in Maintenance.

Checking the Tire Pressure

Service Interval: Before each use or daily

Check the tire pressure every 8 hours or daily to ensure proper levels.

The air pressure range in the front and rear tires is 8–22 psi (55–103 kPa).

The air pressure needed is determined by the payload carried. The lower the air pressure, the less the compaction, smoother the ride, and tire marks are minimized. Lower pressure should not be used for heavy payloads at high speeds.

Higher pressures should be used for heavier payloads at higher speeds. Do not exceed the maximum pressure.

Adding Fuel

The engine runs on clean, fresh diesel fuel with a minimum cetane rating of 40. Purchase fuel in quantities that can be used within 30 days to ensure fuel freshness.

Use summer grade diesel fuel (No. 2-D) at temperatures above 20 F (-7 C) and winter grade diesel fuel (No. 1-D or No. 1-D/2-D blend) below 20 F (-7 C). Use of winter grade diesel fuel at lower temperatures provides lower flash point and pour point characteristics, allowing easier starts and lessening the chances of chemical separation of the fuel due to lower temperatures.

Use of summer grade diesel fuel above 20 F (-7 C) will contribute toward longer life of the fuel pump components.

Important: Never use kerosene or gasoline in place of diesel fuel. Failure to observe this caution will damage the engine.

▲ DANGER

In certain conditions, fuel is extremely flammable and highly explosive. A fire or explosion from fuel can burn you and others and can damage property.

- Fill the fuel tank outdoors, in an open area, when the engine is cold. Wipe up any fuel that spills.
- Never fill the fuel tank inside an enclosed trailer.
- Do not fill the fuel tank completely full. Add fuel to the fuel tank until the level is 1 inch (25 mm) below the bottom of the filler neck. This empty space in the tank allows fuel to expand.
- Never smoke when handling fuel, and stay away from an open flame or where fuel fumes may be ignited by a spark.
- Store fuel in an approved container and keep it out of the reach of children. Never buy more than a 30-day supply of fuel.
- Do not operate without entire exhaust system in place and in proper working condition.

▲ DANGER

In certain conditions during fueling, static electricity can be released causing a spark which can ignite the fuel vapors. A fire or explosion from fuel can burn you and others and can damage property.

- Always place fuel containers on the ground away from your vehicle before filling.
- Do not fill fuel containers inside a vehicle or on a truck or trailer bed because interior carpets or plastic truck bed liners may insulate the container and slow the loss of any static charge.
- When practical, remove fuel-powered equipment from the truck or trailer and refuel the equipment with its wheels on the ground.
- If this is not possible, then refuel such equipment on a truck or trailer from a portable container, rather than from a fuel dispenser nozzle.
- If a fuel dispenser nozzle must be used, keep the nozzle in contact with the rim of the fuel tank or container opening at all times until fueling is complete.

Filling the Fuel Tank

The fuel tank capacity is approximately 6.5 gallons (24.5 l).

1. Shut the engine off and set the parking brake.
2. Clean the area around the fuel tank cap (Figure 10).

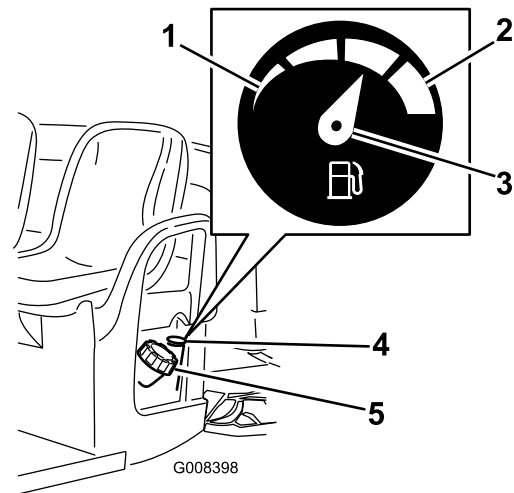

Figure 10

- | | |
|-----------|------------------|
| 1. Empty | 4. Fuel gauge |
| 2. Full | 5. Fuel tank cap |
| 3. Needle | |

3. Remove the fuel tank cap.
4. Fill the tank to about 1 inch (25 mm) below the top of tank, (bottom of the filler neck). This space in the tank allows fuel to expand. **Do not overfill.**

5. Install the fuel tank cap securely. Wipe up any fuel that may have spilled.

Checking the Transmission Oil Level

Service Interval: Before each use or daily

The transaxle fluid level should be at the bottom of the level indicator hole (Figure 11). If it is not, fill the reservoir with the appropriate fluid; refer to Changing the Transaxle Fluid in the Drive System Maintenance section in Maintenance.

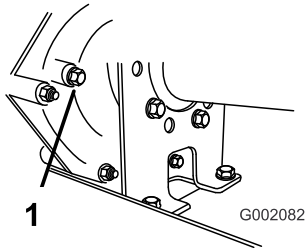

Figure 11

1. Level indicator hole

Starting the Engine

1. Sit in the operator's seat, insert the key into the ignition switch, press down on the brake, and rotate the key clockwise to the On position.

Note: If the back up alarm is installed and the gear shift selector is in Reverse, the buzzer will sound to warn the operator.

2. Release the parking brake.
3. Once the glow plug indicator light turns off, rotate the key counterclockwise to the Start position.

Important: Do not attempt to push or tow the vehicle to get it started.

Stopping the Vehicle

To stop the vehicle, remove your foot from the accelerator pedal and slowly press the brake pedal.

Note: Stopping distance may vary depending on the vehicle load and speed.

Parking the Vehicle

1. Engage the parking brake and rotate the ignition key to Off.
2. Remove the key from the ignition switch to prevent accidental starting.

Operating the Cargo Box

Raising the Box

⚠ WARNING

Driving the vehicle with the cargo box raised may cause the vehicle to tip or roll easier. The box structure may become damaged if you operate the vehicle with the box raised.

- Only operate the vehicle when the cargo box is down.
- After dumping a load, lower the cargo box.

⚠ CAUTION

If a load is concentrated near the back of the box when you release the latches, the box may unexpectedly tip open injuring you or bystanders.

- Center loads in the box if possible.
- Hold the box down and ensure that no one is leaning over the box or standing behind it when releasing the latches.
- Remove all cargo from the box before lifting the box to service the vehicle.

1. Lift the lever on either side of the box and lift the box up (Figure 12).

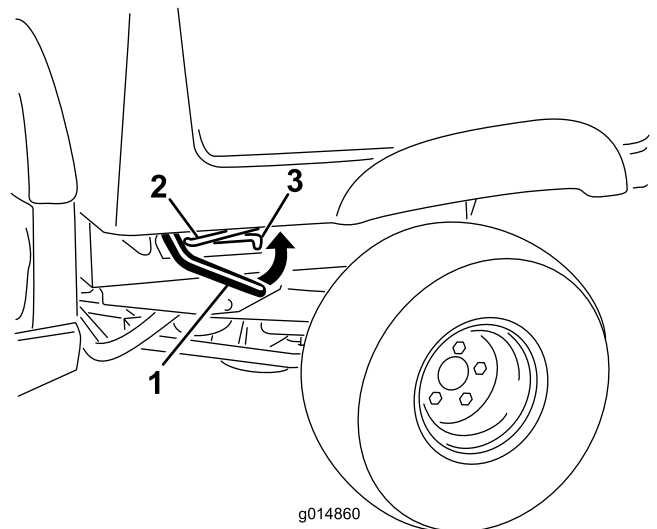

Figure 12

1. Lever
2. Prop rod
3. Detent slot

2. Pull the prop rod into the detent slot, securing the box (Figure 12).

Lowering the Box

⚠ WARNING

The weight of the box may be heavy. Hands or other body parts could be crushed.

Keep hands and other body parts clear when lowering the box.

Pull the prop rod out of the detent slot and lower the box until it latches into place.

Adjusting the Box Latches

If the box latch does not latch tightly, vibrating up and down as you drive the vehicle, you can adjust the latch posts to make the latches fit snugly.

1. Loosen the nut on the end of the latch post (Figure 13).

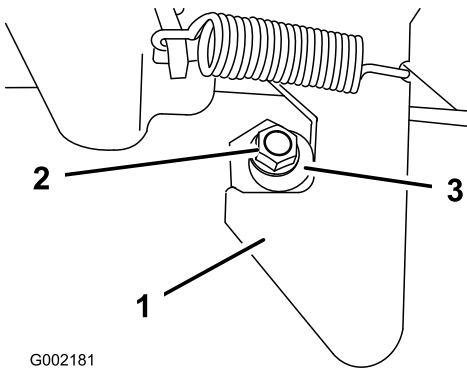

Figure 13

1. Latch
2. Nut
3. Latch post

2. Turn the latch post clockwise until it is snug against the latch and then tighten the nut (Figure 13).
3. Repeat this procedure for the latch on the other side of the vehicle.

Operating the Tailgate Latch

- To open the tailgate, pull outward and lift the latch up, then slowly lower the tailgate (Figure 14).

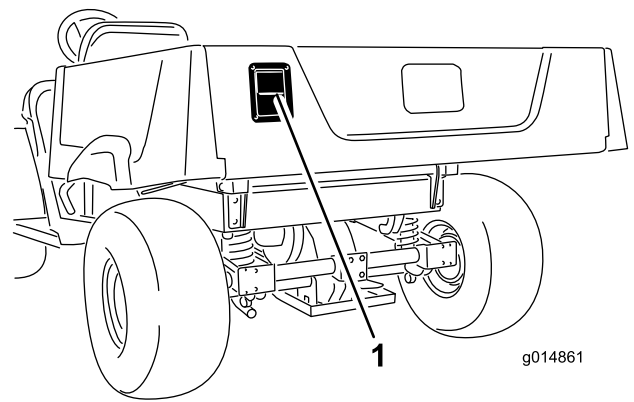

Figure 14

1. Tailgate latch

- To close the tailgate, lift the tailgate upward and push it closed until it locks in place.

Breaking in a New Vehicle

To provide proper performance and long vehicle life, follow these guidelines for the first 100 operating hours:

- Check the fluid and engine oil levels regularly and be alert for indications of overheating in any component of the vehicle.
- After starting a cold engine, let it warm up for about 15 seconds before accelerating.
- Avoid hard braking situations for the first several hours of new vehicle break-in operation. New brake linings may not be at optimum performance until several hours of use has caused the brakes to become burnished (broken-in).
- Vary the vehicle speed during operation. Avoid fast starts and quick stops.
- A break-in oil for engine is not required. Original engine oil is the same type specified for regular oil changes.
- Refer to the Maintenance section for any special low hour checks.
- Check the front suspension positioning and adjust it if necessary; refer to Adjusting the Front Suspension in the Drive System Maintenance section in Maintenance.

Loading the Cargo Box

The capacity of the cargo box is 13 ft³ (0.37 m³). The amount (volume) of material that can be placed in the box without exceeding the vehicle load ratings can vary greatly depending on the density of the material. For example, a level box of wet sand weighs 1500 lb (680 kg), which exceeds the load rating by 250 lb (113 kg). But a level box of wood weighs 650 lb (295 kg), which is under the load rating.

See the table below for load volume limits with various materials:

Material	Max. cargo box capacity (on level ground)
Gravel, dry	3/4 full (approx.)
Gravel, wet	1/2 full (approx.)
Sand, dry	3/4 full
Sand, wet	1/2 full
Wood	Full
Bark	Full
Earth, packed	3/4 full (approx.)

1. Remove the drive belt; refer to Replacing the Drive Belt in the Belt Maintenance section in Maintenance.
2. Affix a tow line to the tongue on the front of the frame (Figure 16).
3. Put the vehicle in neutral and release the parking brake.

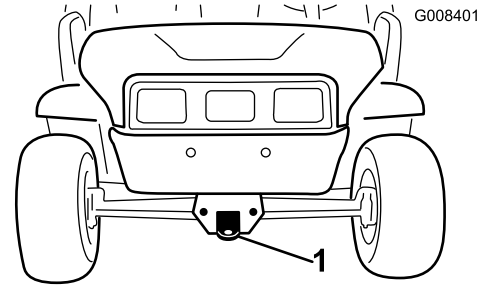

Figure 16

1. Towing tongue and tie down point

Transporting the Vehicle

For moving the vehicle long distances, a trailer should be used. Make sure that the vehicle is secured to the trailer. Refer to Figure 15 and Figure 16 for the location of the tie-down points.

⚠ CAUTION

Loose seats may fall off of the vehicle and trailer when transporting and land on another vehicle or become an obstruction on the road.

Remove the seats or make sure that the seats are securely fastened in the detents.

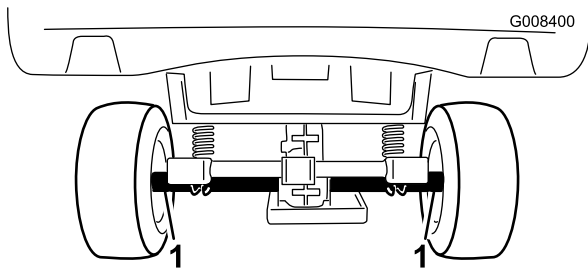

Figure 15

1. Tie down points

Towing a Trailer

The vehicle is capable of pulling trailers. Two types of tow hitches are available for the vehicle, depending on your application. Contact your Authorized Toro Distributor for details.

When hauling cargo or towing a trailer, do not overload your vehicle or trailer. Overloading can cause poor performance or damage to the brakes, axle, engine, transaxle, steering, suspension, body structure, or tires. Always load a trailer with 60% of the cargo weight in the front of the trailer. This places approximately 10% of the Gross Trailer Weight (GTW) on the tow hitch of the vehicle.

The maximum cargo load shall not exceed 1250 lb (567 kg), including the GTW. For example, if the GTW = 400 lb (181.5 kg) then the maximum cargo load = 850 lb (386 kg)

To provide adequate braking and traction, always load the cargo box when trailering. Do not exceed the GTW or GVW limits.

Avoid parking a vehicle with a trailer on a hill. If you must park on a hill, engage the parking brake and block the trailer tires.

Towing the Vehicle

In case of an emergency, the vehicle can be towed for a short distance. However, we do not recommend this as a standard procedure.

⚠ WARNING

Towing at excessive speeds could cause a loss of steering control, resulting in personal injury.

Never tow the vehicle faster than 5 mph (8 km/h).

Towing the vehicle is a two person job. If the machine must be moved a considerable distance, transport it on a truck or trailer; refer to Transporting the Vehicle.

Maintenance

Note: Determine the left and right sides of the machine from the normal operating position.

Recommended Maintenance Schedule(s)

Maintenance Service Interval	Maintenance Procedure
After the first 8 hours	<ul style="list-style-type: none"> • Check the condition of the drive belt.
After the first 50 hours	<ul style="list-style-type: none"> • Change the engine oil.
Before each use or daily	<ul style="list-style-type: none"> • Check the engine oil. • Check the tire pressure. • Check the transmission oil level. • Check gear shift operation. • Inspect the primary drive clutch. • Check the radiator coolant level. • Check the brake fluid level.
Every 50 hours	<ul style="list-style-type: none"> • Check the battery cable connections for wear or damage. • Check the battery electrolyte level.
Every 100 hours	<ul style="list-style-type: none"> • Grease the bearings and bushings. • Check the operation of the Neutral gear shift position. • Inspect the condition and wear of the tires. • Torque the wheel lug nuts to 80-90 ft-lb (108-122 N-m). • Check the front wheel toe-in and camber. • Clean the engine cooling areas (twice as often in special operating conditions; refer to Maintaining the Vehicle under Special Operating Conditions). • Inspect the brakes.
Every 150 hours	<ul style="list-style-type: none"> • Change the engine oil. (twice as often in special operating conditions; refer to Maintaining the Vehicle under Special Operating Conditions) • Change the oil filter. (twice as often in special operating conditions; refer to Maintaining the Vehicle under Special Operating Conditions)
Every 200 hours	<ul style="list-style-type: none"> • Replace the air filter element. • Clean the primary drive clutch (more often in dusty or muddy conditions). • Check the parking brake operation. • Check the condition and tension of the drive belt.
Every 400 hours	<ul style="list-style-type: none"> • Inspect the fuel lines and connections.
Every 800 hours	<ul style="list-style-type: none"> • Replace the fuel filter. • Change the transaxle fluid.
Every 1,000 hours	<ul style="list-style-type: none"> • Change the radiator coolant. • Change the brake fluid.
Yearly	<ul style="list-style-type: none"> • Complete all yearly maintenance procedures specified in the Engine Operator's Manual.

Important: Refer to your *Engine Operator's Manual* for additional maintenance procedures.

Daily Maintenance Checklist

Duplicate this page for routine use.

Maintenance Check Item	For the week of:						
	Mon.	Tues.	Wed.	Thurs.	Fri.	Sat.	Sun.
Check brake and parking brake operation.							
Check gear shift/neutral operation.							
Check fuel level.							
Check engine oil level.							
Check transaxle oil level.							
Inspect air filter.							
Inspect engine cooling fins.							
Check unusual engine noises.							
Check unusual operating noises.							
Check clutch operation.							
Check tire pressure.							
Check fluid leaks.							
Check instrument operation.							
Check accelerator operation.							
Lubricate all grease fittings.							
Touch up damaged paint.							

⚠ CAUTION

If you leave the key in the ignition switch, someone could accidentally start the engine and seriously injure you or other bystanders.

Remove the key from the ignition before you do any maintenance.

⚠ WARNING

The bed must be raised to perform some routine maintenance.

A raised bed can fall and injure persons that are underneath it.

- Always use the prop rod to hold the bed up before working under it.
- Remove any load material from the bed before working under it.

Premaintenance Procedures

Maintaining the Vehicle under Special Operating Conditions

If the vehicle is subjected to any of the conditions listed below, maintenance should be performed twice as frequently.

- Desert operation
- Cold climate operation (below 50° F [10 degrees C])
- Trailer towing
- Driving time typically less than 5 minutes
- Frequent operation in dusty conditions
- Construction work
- After extended operation in mud, sand, water, or similar dirty conditions, have your brakes inspected and cleaned as soon as possible. This will prevent any abrasive material from causing excessive wear.
- Under frequent heavy duty operating conditions, lubricate all grease fittings and inspect air cleaner daily to prevent excessive wear.

Jacking the Vehicle

Whenever the engine is run for routine maintenance and/or engine diagnostics, the rear wheels of the vehicle should be 1 inch (25 mm) off the ground with the rear axle supported on jack stands.

▲ DANGER

The vehicle may be unstable when using a jack. It could slip off the jack, injuring anyone beneath it.

- Do not start the engine while the vehicle is on a jack.
- Always remove the key from the ignition before getting off of the vehicle.
- Block the tires when the vehicle is on a jack.

The jacking point at the front of the vehicle is on the front of the frame behind the towing tongue (Figure 17) The jacking point at the rear of the vehicle is under the axle tubes (Figure 18).

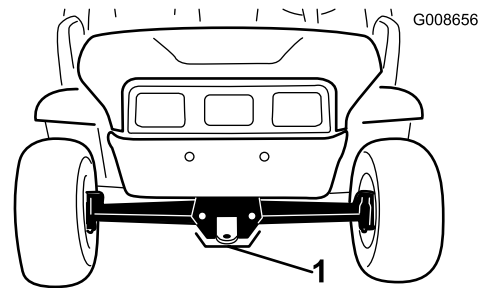

Figure 17

1. Front jacking point

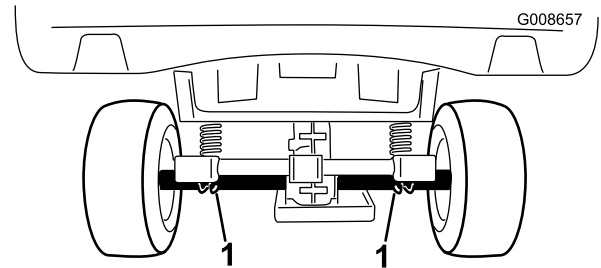

Figure 18

1. Rear jacking points

Accessing the Hood

1. Release the rubber straps on both sides of the hood (Figure 19).

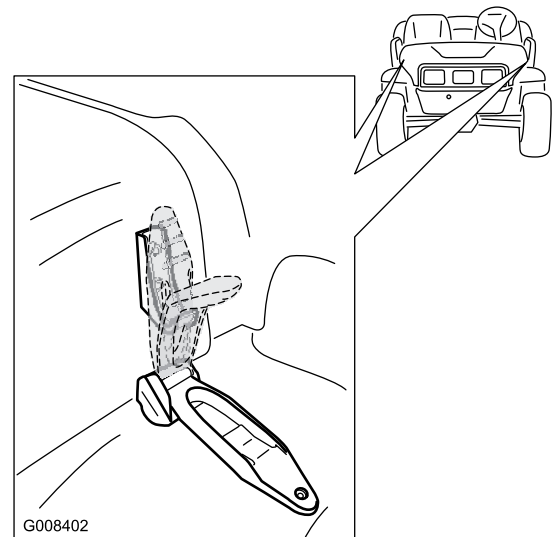

Figure 19

2. Raise the hood.
3. Lower the hood to close and use rubber retaining straps to secure the hood.

Lubrication

Lubricate all of the bearings and bushings every 100 hours or once a year, whichever occurs first. Grease them more frequently when using the vehicle for heavy-duty operations.

Grease Type: Number 2 General Purpose Lithium Base Grease

Adding Grease

Service Interval: Every 100 hours

1. Wipe the grease fitting clean so foreign matter cannot be forced into the bearing or bushing.
2. Pump grease into the bearing or bushing.
3. Wipe off excess grease.

The grease fittings are located at the four tie rod ends (Figure 20) and the two king pins (Figure 21).

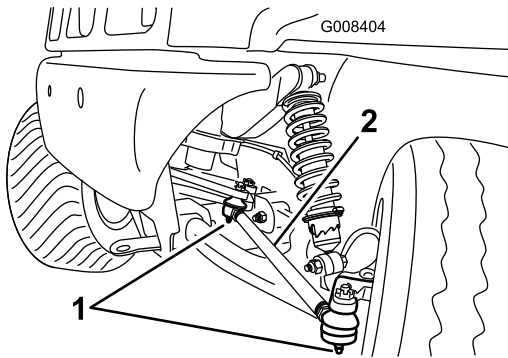

Figure 20
Left side shown

1. Grease fitting
2. Tie rod

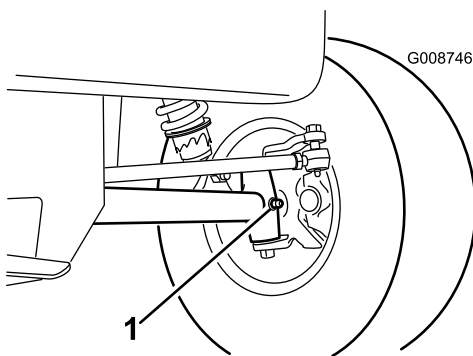

Figure 21
Left side shown

1. Grease fitting

Engine Maintenance

Servicing the Air Cleaner

Check the air cleaner body for damage which could possibly cause an air leak. Replace a damaged air cleaner body.

Ensure the cover is sealing around the air cleaner body.

Air Cleaner Filter: Inspect after every 100 operating hours; replace after every 200 hours or sooner if dirty or damaged.

Note: Service the air cleaner more frequently (every few hours) if operating conditions are extremely dusty or sandy.

Removing the Filter Element

1. Pull the latch outward and rotate the air cleaner cover counterclockwise (Figure 22).
2. Remove the cover from the air cleaner body.
3. Gently slide the filter out of the air cleaner body (Figure 22) to reduce the amount of dust dislodged. Avoid knocking the filter against the air cleaner body.

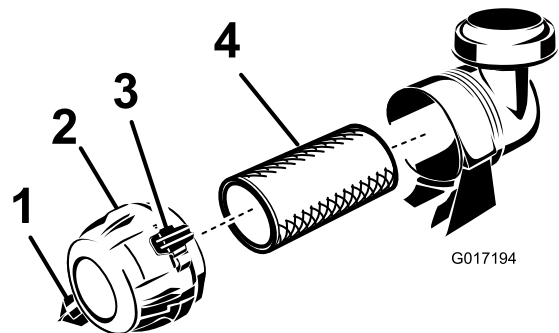

Figure 22

1. Dirt ejection port
2. Cover
3. Latch
4. Air filter

4. Inspect the filter and discard it if it is damaged.

Installing the Filter Element

Service Interval: Every 200 hours

Important: To prevent engine damage, always operate the engine with the complete air cleaner assembly installed.

Note: Cleaning of the used element is not recommended due to the possibility of damage to the filter media.

1. Inspect the new filter for shipping damage, checking the sealing end of the filter and the body. **Do not use a damaged element.**
2. Insert the new filter by applying pressure to the outer rim of the element to seat it in the canister. Do not apply pressure to the flexible center of the filter.

Fuel System Maintenance

Inspecting Fuel Lines and Connections

Service Interval: Every 400 hours

Check the fuel lines and connections every 400 operating hours or yearly, whichever occurs first. Inspect them for deterioration, damage, or loose connections.

Replacing the Fuel Filter

Service Interval: Every 800 hours

Replace the fuel filter every 800 operating hours or yearly, whichever occurs first.

1. Raise the box and support it with the prop rod.
2. Place a clean container under the fuel filter.
3. Unscrew the fuel filter from the bracket (Figure 25).

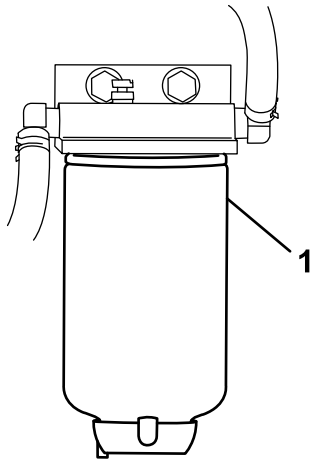

Figure 25

1. Fuel filter

Electrical System Maintenance

Replacing the Fuses

There are 7 fuses in the electrical system. They are located beneath the dash on the driver's side (Figure 26).

Alarm/Power Point	10 A
Engine	10 A
Headlights	10 A
Machine fuse	15 A
Lift	15 A
Rear lift	15 A
Horn	30 A

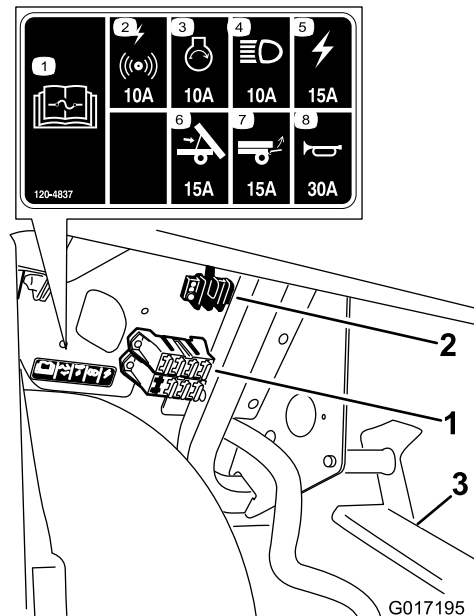

Figure 26

1. Fuse block
2. Ground block
3. Pedal assembly

4. Install the replacement filter by turning it until the filter contacts the top of the bracket, then tighten it an additional 3/4 of a turn.

Replacing the Headlights

Before performing any maintenance set the parking brake, turn the ignition off, and remove the key.

Release the retaining straps on the hood and raise the hood to access the headlights.

Replacing the Bulbs

⚠ CAUTION

The halogen bulbs become extremely hot when in operation. Handling a hot bulb can cause severe burns and personal injury.

Always allow enough time for the bulbs to cool before replacing them. Use care whenever handling the bulb.

⚠ CAUTION

Any surface contamination can damage the headlight bulb and lead to its failure or explosion creating a serious safety hazard.

Head light lamps should be handled without touching the clear quartz, either by using a clean paper towel or carefully holding the base.

Specification: See your *Parts Catalog*.

1. Disconnect the electrical harness from the bulb housing on the back of the lamp.
2. Remove the bulb assembly by turning it 1/4 turn counter clockwise and moving it rearward, out of the lamp housing.
3. Remove the bulb from the base taking care not to touch the halogen quartz.
4. Install a new bulb on the base. Use a paper towel to grasp the new bulb with handling it to avoid contaminating the surface.
5. Insert the new bulb and assembly into the headlight housing and secure by turning it 1/4 turn clockwise to lock it in place.
6. Connect the electrical harness.

Replacing the Headlight

When removing or replacing the headlight assembly, disconnect the wiring harness to the bulb assembly if the bulb is to be removed with the lamp.

1. Remove the speed clips and washers securing the headlight in place. Retain all parts.
2. Remove the headlight assembly by moving it forward through the opening in the front bumper (Figure 27).

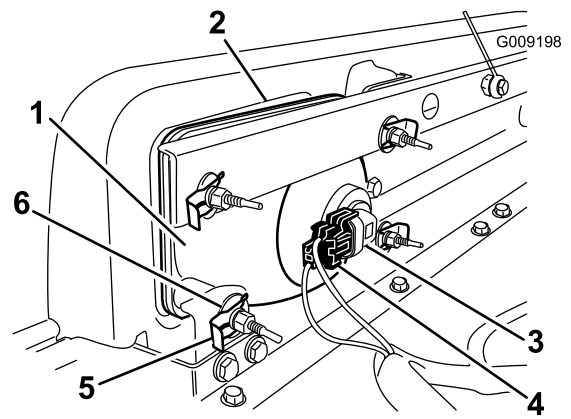

Figure 27

- | | |
|----------------------------|--------------------------------------|
| 1. Headlight | 4. Headlight bulb harness connection |
| 2. Opening in front end | 5. Speed clip |
| 3. Headlight bulb assembly | 6. Flat washer |

3. Install the new headlight through the opening in the bumper (Figure 27). Ensure the adjustment posts are lined up with the holes in the mounting bracket in the bumper.
4. Secure the headlight assembly with the washers and speed clips removed previously.
5. Attach the headlight to the wire harness removed previously.
6. Adjust the headlights to direct the beams to the desired position.

Adjusting the Headlights

Use the following procedure to adjust the headlight beam position whenever a headlight assembly is replaced or removed.

1. Turn the ignition key to the On position and turn on the headlights.
2. At the headlight assembly, use the fasteners to pivot the headlight assembly and affect the cast beam position.

Servicing the Battery

WARNING

CALIFORNIA Proposition 65 Warning

Battery posts, terminals, and related accessories contain lead and lead compounds, chemicals known to the State of California to cause cancer and reproductive harm.
Wash hands after handling.

Important: Do not jump start the vehicle.

Always keep the battery clean and fully charged. Use a paper towel to clean the battery and battery box. If the battery terminals are corroded, clean them with a solution of four parts water and one part baking soda. Apply a light coating of grease to the battery terminals to prevent corrosion.

Voltage: 12 volt with 540 cold cranking Amps @ 0 degrees F (-18 degrees C).

Removing the Battery

1. Position the vehicle on a level surface, set the parking brake, turn the ignition off, and remove the key.
2. Locate the battery on the right side of the machine, behind the passenger seat. Remove the battery cover.
3. Disconnect the negative (black) ground cable from the battery post.

⚠ WARNING

Incorrect battery cable routing could damage the vehicle and cables, causing sparks. Sparks can cause the battery gasses to explode, resulting in personal injury.

- Always disconnect the negative (black) battery cable before disconnecting the positive (red) cable.
- Always reconnect the positive (red) battery cable before reconnecting the negative (black) cable.
- Always keep the battery strap in place to protect and secure the battery.

⚠ WARNING

Battery terminals or metal tools could short against metal vehicle components, causing sparks. Sparks can cause the battery gasses to explode, resulting in personal injury.

- When removing or installing the battery, do not allow the battery terminals to touch any metal parts of the vehicle.
 - Do not allow metal tools to short between the battery terminals and metal parts of the vehicle.
4. Disconnect the positive (red) cable from the battery post.
 5. Remove the fasteners securing the battery hold down. Remove the hold down and retain all parts.
 6. Remove the battery from the holder box.

Installing the Battery

Service Interval: Every 50 hours

1. Set the battery into the battery holder box so the battery posts are away from the vehicle frame.
2. Install the battery hold down and secure it with fasteners removed previously.
3. Connect the positive (red) cable to the positive (+) battery post and the negative (black) cable to the negative (-) battery post. Slide the rubber boot over the positive battery post.
4. Install the battery cover.

Important: Always keep the battery hold-down in place to protect and secure the battery.

Checking the Electrolyte Level

Service Interval: Every 50 hours

Note: This procedure is only necessary for batteries in Model No. 07359TC.

Check the electrolyte level every 50 operating hours or, if the machine is in storage, every 30 days.

1. Locate the battery on the right side of the machine, behind the passenger seat. Remove the battery cover.
2. Remove the filler caps. If the electrolyte is not up to the fill line, add the required amount of distilled water; refer to Adding Water to the Battery.

⚠ DANGER

Battery electrolyte contains sulfuric acid which is a deadly poison and causes severe burns.

- Do not drink electrolyte or allow it to contact your skin, eyes or clothing. Wear safety glasses to shield your eyes and rubber gloves to protect your hands.
- Fill the battery where clean water is always available for flushing the skin.

Adding Water to the Battery

Note: This procedure is only necessary for batteries in Model No. 07359TC.

The best time to add distilled water to the battery is just before you operate the machine. This lets the water mix thoroughly with the electrolyte solution.

1. Clean the top of the battery with a paper towel.
2. Remove the filler caps from the battery and slowly fill each cell with distilled water until the level is up to the fill line. Replace the filler caps.

Important: Do not overfill the battery. Electrolyte will overflow onto other parts of the vehicle and severe corrosion and deterioration will result.

Charging the Battery

Important: Always keep the battery fully charged (1.260 specific gravity). This is especially important to prevent battery damage when the temperature is below 32 degreesF (0 degreesC).

1. Remove the battery from the machine; refer to Removing the Battery.
2. Connect a 3 to 4 amp battery charger to the battery posts. Charge the battery at a rate of 3 to 4 amp for 4 to 8 hours (12 volts). Do not overcharge the battery.

⚠ WARNING

Charging the battery produces gasses that can explode.

Never smoke near the battery and keep sparks and flames away from battery.

3. Install the battery in the chassis; refer to Installing the Battery.

Storing the Battery

If the machine will be stored for more than 30 days, remove the battery and charge it fully. Either store it on the shelf or on the machine. Leave the cables disconnected if it is stored on the machine. Store the battery in a cool atmosphere to avoid quick deterioration of the charge in the battery. To prevent the battery from freezing, make sure it is fully charged.

Drive System Maintenance

Checking and Adjusting Neutral

Service Interval: Every 100 hours

When performing routine maintenance and/or engine diagnostics, the transaxle must be shifted into neutral (Figure 28). The vehicle has a neutral position on the shift lever, which controls the neutral in the transaxle. The following steps should be taken to make sure that the neutral shift lever operates the transaxle neutral correctly:

1. Set the shift lever into the Neutral position.
2. Ensure that the neutral bracket is in the neutral position (level to the cable mounting bracket located below the shift bracket) by turning the driven clutch (Figure 28). The vehicle should not roll back and forth. If it does, manually move the neutral bracket to the neutral position.

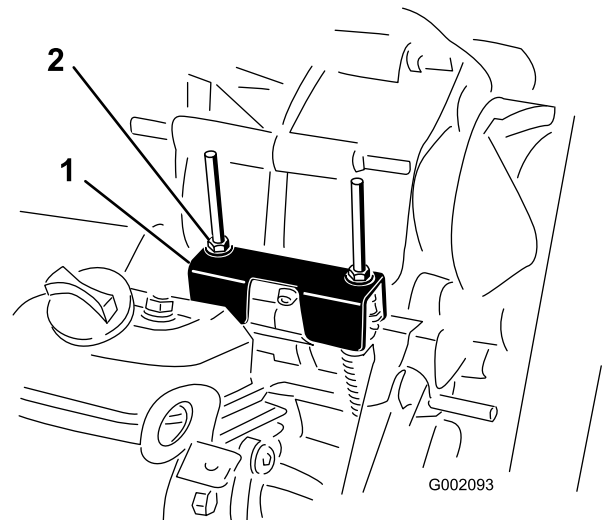

Figure 28

1. Neutral bracket 2. Locknuts

3. Tighten one of the locknuts (Figure 28) to achieve a gap of 0.03-0.06 inch (0.76-1.52 mm).

Note: You must hold the threaded shaft below the bracket to tighten the locknut on top.

4. Tighten the other locknut to achieve a gap of 0.03-0.06 inch (0.76-1.52 mm).
5. Pull up on each shift cable and ensure that there is a 0.03-0.06 inch (0.76-1.52 mm) gap between the nut/washer and the neutral bracket (Figure 29). If there is not a gap adjust the nuts to achieve a gap of 0.03-0.06 inch (0.76-1.52 mm).

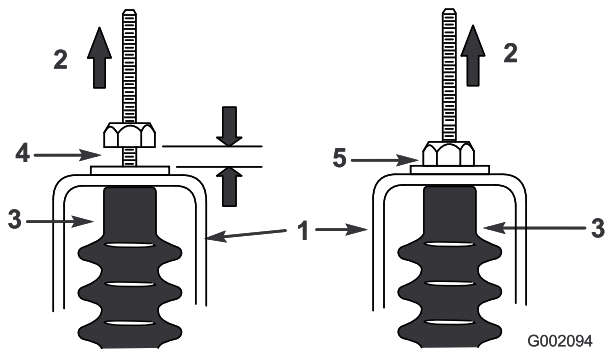

Figure 29

- | | |
|--------------------|--|
| 1. Neutral bracket | 4. 0.03-0.06 inch (0.76-1.52 mm) gap |
| 2. Pull up | 5. Wrong, adjust to achieve a gap of 0.03-0.06 inch (0.76-1.52 mm) |
| 3. Cable boot | |

- Start the engine and shift into Forward, Reverse, and Neutral several times to ensure that the neutral bracket is operating properly.

Inspecting the Tires

Service Interval: Every 100 hours—Inspect the condition and wear of the tires.

Every 100 hours—Torque the wheel lug nuts to 80-90 ft-lb (108-122 N-m).

Check the tire condition at least every 100 hours of operation. Operating accidents, such as hitting curbs, can damage a tire or rim and also disrupt wheel alignment, so inspect tire condition after an accident.

Check the wheels to ensure that they are mounted securely. Torque the lug nuts to 80-90 ft-lb (108-122 N-m).

Adjusting Front Wheel Toe-In and Camber

Service Interval: Every 100 hours/Yearly (whichever comes first)—Check the front wheel toe-in and camber.

Important: You will need to obtain tool number **TORO6010** from your Toro Distributor to perform this procedure

The toe-in should be 0-1/4 inch (0-6 mm) and the camber should be 0+1/2 degree, i.e., the bottom of the wheel rims angled in 0.09 inch (2.3 mm) more than the top, with the following parameters:

- Check the tire pressure to ensure that the front tires are inflated to 12 psi (82 kPa).
- Either, add weight to the driver's seat equal to the average operator who will run the machine or have an operator sit on the seat. The weight or operator must remain on the seat for the duration of the procedure.
- On a level surface, roll the vehicle straight back 6 to 10 ft (2 to 3 m) and then straight forward to the original starting position. This will allow the suspension to settle into the operating position.
- Measure the toe-in with the wheels facing straight ahead.
 - To check the camber, place a 90 degree square on the ground with the vertical edge touching the face of the tire (Figure 30).

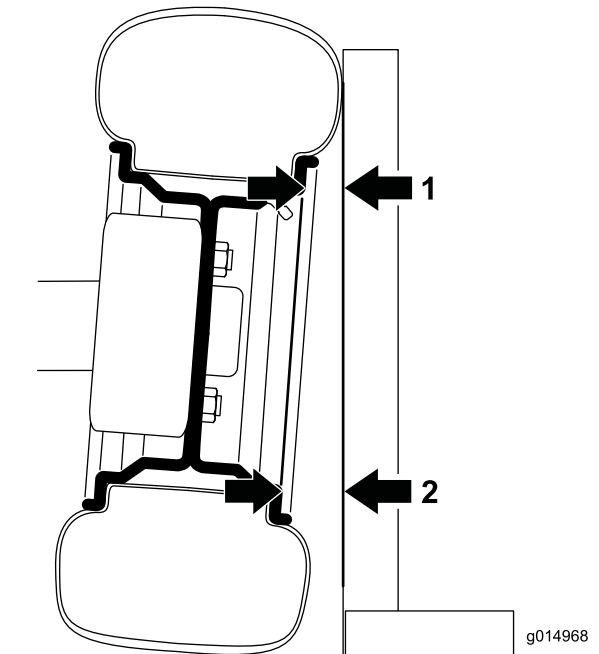

Figure 30

Left, front wheel shown from the front; the angle is exaggerated for illustrative purposes

- Measure here
- Measure here—should be 0.09 inch (2.3 mm) larger than the measurement at 1

- Measure from the same part of the rim on the top and bottom of the tire to the square (Figure 30). The distance of the bottom measurement should be 0.09 inch (2.3 mm) larger than the top measurement. Complete the measurement on both front tires before adjusting.

Complete the following procedure for each tire that needs adjusting:

- Using tool TORO6010, rotate the collar on the shock absorber to change the length of the spring (Figure 31).
 - If the bottom measurement was too short, reduce the length of the spring.
 - If the bottom measurement was too long, increase the length of the spring.

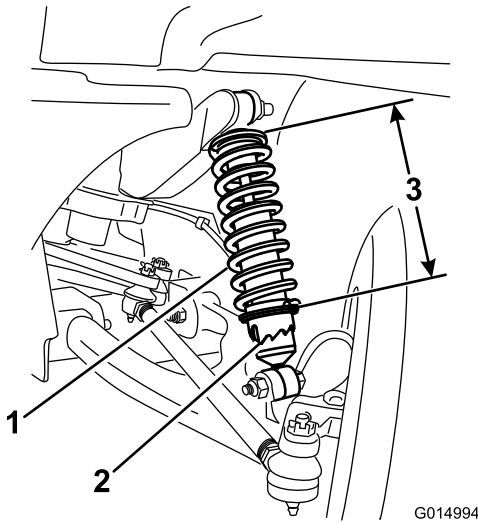

Figure 31

- Shock absorber spring
- Collar
- Spring length

- On a level surface, roll the vehicle straight back 6 to 10 ft (2 to 3 m) and then straight forward to the original starting position.

- Repeat this procedure, starting with step 1 until the camber is set correctly for both front wheels.

- Measure the distance between both of the front tires at the axle height at both the front and rear of the front tires (Figure 32).

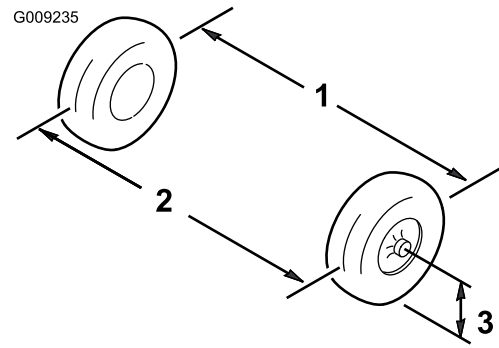

Figure 32

- Tire center line-back
- Tire center line-front
- Axle center line

- If the measurement does not fall within 0-1/4 inch (0-6 mm), loosen the jam nuts at both ends of the tie rods (Figure 33).

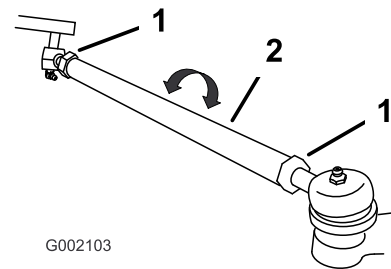

Figure 33

- Jam nut
- Tie rod

- Rotate both tie rods to move the front of the tire inward or outward.
- Tighten the tie rod jam nuts when the adjustment is correct.
- Ensure that there is full travel of the steering wheel in both directions.

Inspecting the Primary Drive Clutch

Service Interval: Before each use or daily

Clutch operation should be monitored daily for proper shifting. If shifting is sticky or sluggish, or the clutch does not return completely to neutral when idling, the clutch requires a simple cleaning.

Note: Focus debris removal in and around moving parts.

- Stop the engine, remove the key, and set the parking brake.
- Raise and latch the cargo box.
- Remove dirt and mud buildup with water and dry immediately with compressed air to remove excess water and debris.

Note: Remaining debris may be removed using a fast drying contact cleaner.

Maintaining the Primary Drive Clutch

Service Interval: Every 200 hours—Clean the primary drive clutch (more often in dusty or muddy conditions).

Note: Operating the vehicle with a dirty clutch can increase wear to internal components.

1. Stop the engine, remove the key, and set the parking brake.
2. Raise and latch the cargo box.
3. Remove the 6 flange-head bolts securing the clutch cover. Set aside the cover, spacer, and spring (Figure 34).

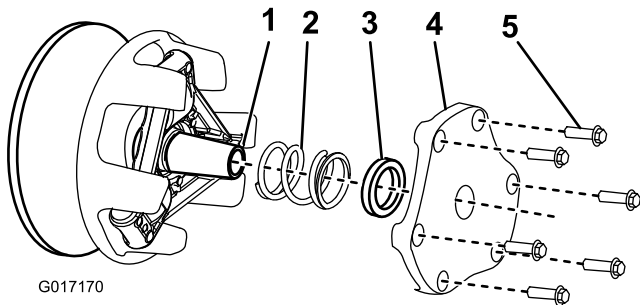

Figure 34

- | | |
|-----------------|---------------------|
| 1. Clutch shaft | 4. Clutch cover |
| 2. Spring | 5. Flange-head bolt |
| 3. Spacer | |

4. Remove dirt and mud buildup with water and dry immediately with compressed air to remove excess water and debris.

5. Remove any remaining debris using a fast drying contact cleaner or brake cleaner.

Note: Focus debris removal in and around moving parts.

6. If debris or buildup exists around the belt or along the clutch shaft, use a fine abrasive pad or similar product to remove it.

7. Install the spring, clutch cover, and flange-head bolts. Torque the bolts to 105-120 in-lb (12-13.5 N-m).

Changing the Transaxle Fluid

Service Interval: Every 800 hours

Change the transaxle fluid every 800 operating hours or yearly, whichever occurs first.

1. Position the vehicle on a level surface, set the parking brake, turn the ignition off, and remove the key.

2. Remove the drain plug from the right side of the reservoir (Figure 35) and let the fluid flow into a drain pan. Install and tighten the plug when the fluid stops draining.

Note: Dispose of the used oil at a certified recycling center.

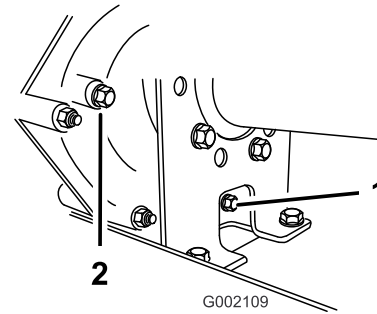

Figure 35

- | | |
|---------------|-------------------------|
| 1. Drain plug | 2. Level indicator hole |
|---------------|-------------------------|

3. Fill the reservoir (Figure 36) with approximately 1-1/2 qt. (1.4 liters) of SAE 10W30 motor oil or until the oil level is at the bottom of the level indicator hole (Figure 35).

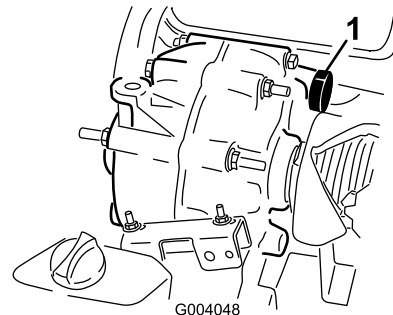

Figure 36

- | |
|-------------|
| 1. Oil fill |
|-------------|

4. Start the engine and operate it to fill the system. Recheck the oil level and replenish it, if required.

Cooling System Maintenance

Cleaning the Engine Cooling Areas

Service Interval: Every 100 hours

Clean the external surfaces of the engine every 100 operating hours or more often under extremely dusty and dirty conditions.

Important: Never clean the engine with pressurized water because water could contaminate the fuel system.

Filling the Radiator

Initial Fill/Filling after Flushing

Service Interval: Every 1,000 hours/Every 2 years (whichever comes first)

Note: Use a 50/50 mix of Ethylene Glycol and water for coolant.

1. Position the vehicle on a level surface, set the parking brake, turn the ignition off, and remove the key.

⚠ CAUTION

If the engine has been running, the pressurized, hot coolant can escape and cause burns.

- Do not open the radiator cap when the engine is running.
 - Allow engine to cool at least 15 minutes or until the radiator cap is cool enough to touch without burning your hand.
 - Use a rag when opening the radiator cap, and open the cap slowly to allow steam to escape.
2. Remove the fill cap (Figure 37) and fill with coolant.

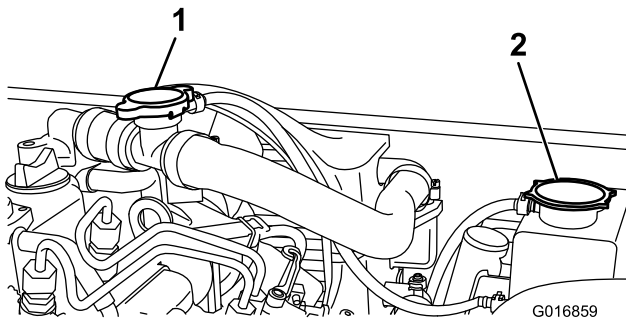

Figure 37

1. Fill cap
2. Radiator overflow tank cap

3. Replace the fill cap and remove the radiator overflow tank cap (Figure 37).

Note: Never leave both caps off at the same time. This will adversely affect the filling of the tank.

4. Fill with coolant to the bottom of the filler neck. **Do not overfill.** Replace the radiator overflow tank cap and clean any spills.

Checking and Refilling the Radiator

Service Interval: Before each use or daily

Note: Use a 50/50 mix of Ethylene Glycol and water for coolant.

1. Position the vehicle on a level surface, set the parking brake, turn the ignition off, and remove the key.

⚠ CAUTION

If the engine has been running, the pressurized, hot coolant can escape and cause burns.

- Do not open the radiator cap when the engine is running.
 - Allow engine to cool at least 15 minutes or until the radiator cap is cool enough to touch without burning your hand.
 - Use a rag when opening the radiator cap, and open the cap slowly to allow steam to escape.
2. Remove the radiator overflow tank cap (Figure 37).
 3. If the coolant level is low, fill the tank with coolant to the bottom of the filler neck. **Do not overfill.**
 4. Replace the radiator overflow tank cap and clean any spills.

Brake Maintenance

Inspecting the Brakes

Service Interval: Every 100 hours

Brakes are a critical safety component of the vehicle. As with all safety components, they should be closely inspected at regular intervals to ensure optimum performance and safety. The following inspections should be done every 100 hours:

- Inspect the brake shoes for wear or damage. If the lining (brake pad) thickness is less than 1/16 inch (1.6 mm), the brake shoes should be replaced.
- Inspect the backing plate and other components for signs of excessive wear or deformation. If any deformation is found, the appropriate components must be replaced.
- Check the brake fluid level; refer to Checking the Brake Fluid Level.

Checking the Brake Fluid Level

Service Interval: Before each use or daily

Every 1,000 hours

The brake fluid reservoir is filled and shipped from the factory with DOT 3 brake fluid. Check the level before the engine is first started and every 8 hours or daily, thereafter.

1. Park the machine on a level surface, set the parking brake, turn the ignition off, and remove the key.
2. Remove the rubber plug in the center and on top of the dash to gain access to the master brake cylinder and reservoir.
3. Look at the side of the reservoir. The level should be above the Minimum line (Figure 38). If the fluid level is low, clean the area around the cap, remove the cap, and fill the reservoir to above the Minimum line. Do not overfill.

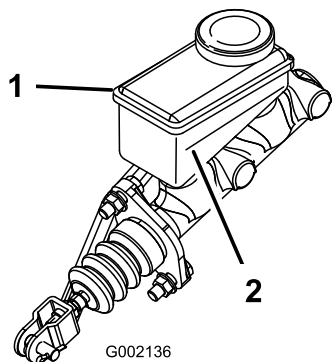

Figure 38

1. Brake fluid reservoir
2. Minimum line

Adjusting the Parking Brake

Check the parking brake adjustment every 200 hours.

1. Pry the rubber cover off of the parking brake.
2. Loosen the set screw securing the knob to the parking brake lever (Figure 39).

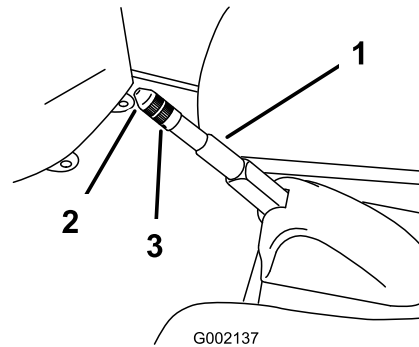

Figure 39

1. Parking brake lever
2. Knob
3. Set screw

3. Rotate the knob until a force of 30-35 lb (133-156 N) is required to actuate the lever.
4. Tighten the set screw and install the rubber cover.

Belt Maintenance

Servicing the Drive Belt

New belts must be broken-in before they will shift properly. A belt will brake-in within the first two hours of normal operation.

Checking the Drive Belt

Service Interval: After the first 8 hours
Every 200 hours

Note: If the unit continues to move when the engine is at low idle, the clutches may be dirty and require washing.

1. Park the machine on a level surface, shift into Neutral, set the parking brake, turn the ignition off, and remove the key.
2. Raise the bed and secure it with the prop rod.
3. Rotate and inspect the belt (Figure 40) for excessive wear or damage. Replace the belt if necessary.

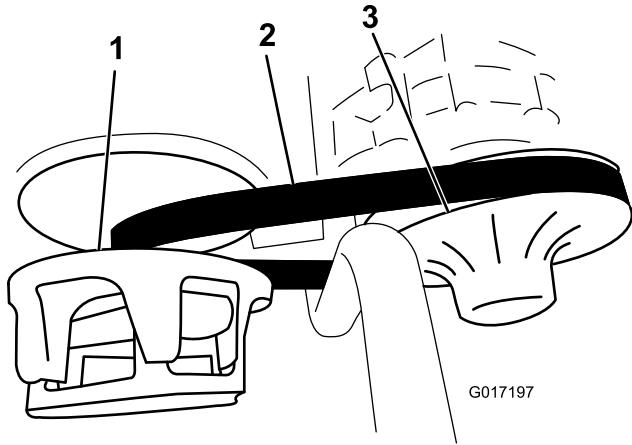

Figure 40

1. Primary clutch
2. Drive belt
3. Secondary clutch

Replacing the Drive Belt

1. Rotate and route the belt over the secondary clutch (Figure 40).
2. Remove the belt from the primary clutch (Figure 40).
3. To replace the belt, reverse the procedure.

Checking the Belt Pull Bumper

Note: The belt pull bumper only needs to be checked when troubleshooting vibration, performing a rebuild, or experiencing an engine mount failure.

The belt pull bumper (Figure 41) should maintain a gap of 0.09 inches (2.2 mm). If the bumper is too close to the engine

bracket, the belt will cause excessive vibration. If the bumper is too far from the engine bracket, the belt will cause harmful engine stress. To adjust the gap, loosen the 3 flange-head bolts securing the bracket to the frame and slide the bracket the appropriate distance. Once the gap is correct, tighten the 3 flange-head bolts.

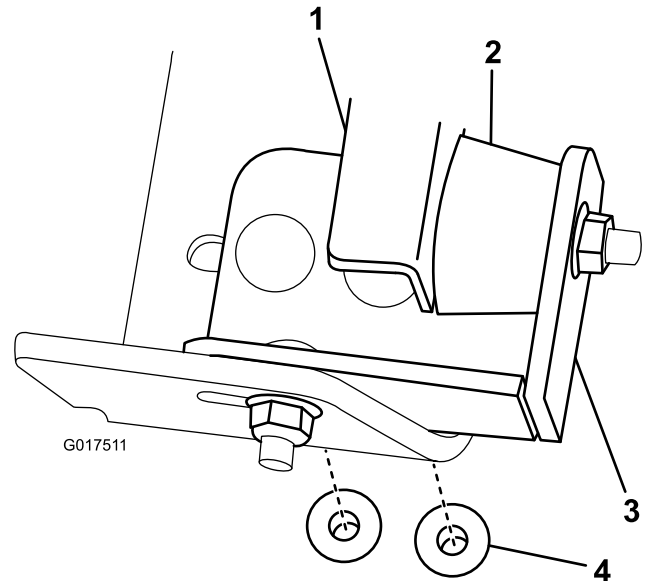

Figure 41

1. Engine bracket
2. Bumper
3. Bracket
4. Flange-head bolt

Cleaning

Washing the Vehicle

The vehicle should be washed as needed. Use water alone or with a mild detergent. A rag may be used, however the hood will lose some of its luster.

Important: Pressurized water is not recommended when washing the machine. It may damage the electrical system, loosen important decals, or wash away necessary grease at friction points. Avoid excessive use of water, especially near the control panel, engine, and battery.

Storage

1. Position the machine on a level surface, set the parking brake, stop the engine, and remove the ignition key.
2. Clean dirt and grime from the entire machine, including the outside of the engine's cylinder head fins and blower housing.

Important: You can wash the machine with mild detergent and water. Do not use high pressure water to wash the machine. Pressure washing may damage the electrical system or wash away necessary grease at friction points. Avoid excessive use of water, especially near the control panel, lights, engine, and the battery.

3. Inspect the brakes; refer to Inspecting the Brakes in the Brake Maintenance section in Maintenance.
4. Service the air cleaner; refer to Servicing the Air Cleaner in the Engine Maintenance section in Maintenance.
5. Grease the machine; refer to Lubrication section in Maintenance.
6. Change the engine oil; refer to Servicing Engine Oil in the Engine Maintenance section in Maintenance.
7. Check the tire pressure; refer to Checking the Tire Pressure.
8. Flush the fuel tank with fresh, clean diesel fuel.
9. Remove the battery from the chassis, check the electrolyte level, and charge it fully; refer to Servicing the Battery in the Electrical System Maintenance section in Maintenance.

Note: Do not connect the battery cables to the battery posts during storage.

Important: The battery must be fully charged to prevent it from freezing and being damaged at temperatures below 32 degreesF (0 degreesC). A fully charged battery maintains its charge for about 50 days at temperatures lower than 40 degreesF (4 degreesC). If the temperatures will be above 40 degreesF (4 degreesC), check the water level in the battery and charge it every 30 days.

10. Check and tighten all bolts, nuts, and screws. Repair or replace any part that is damaged.
11. Paint all scratched or bare metal surfaces.
Paint is available from your Authorized Service Dealer.
12. Store the machine in a clean, dry garage or storage area.
13. Remove the ignition key and put it in a safe place out of the reach of children.
14. Cover the machine to protect it and keep it clean.

Schematics

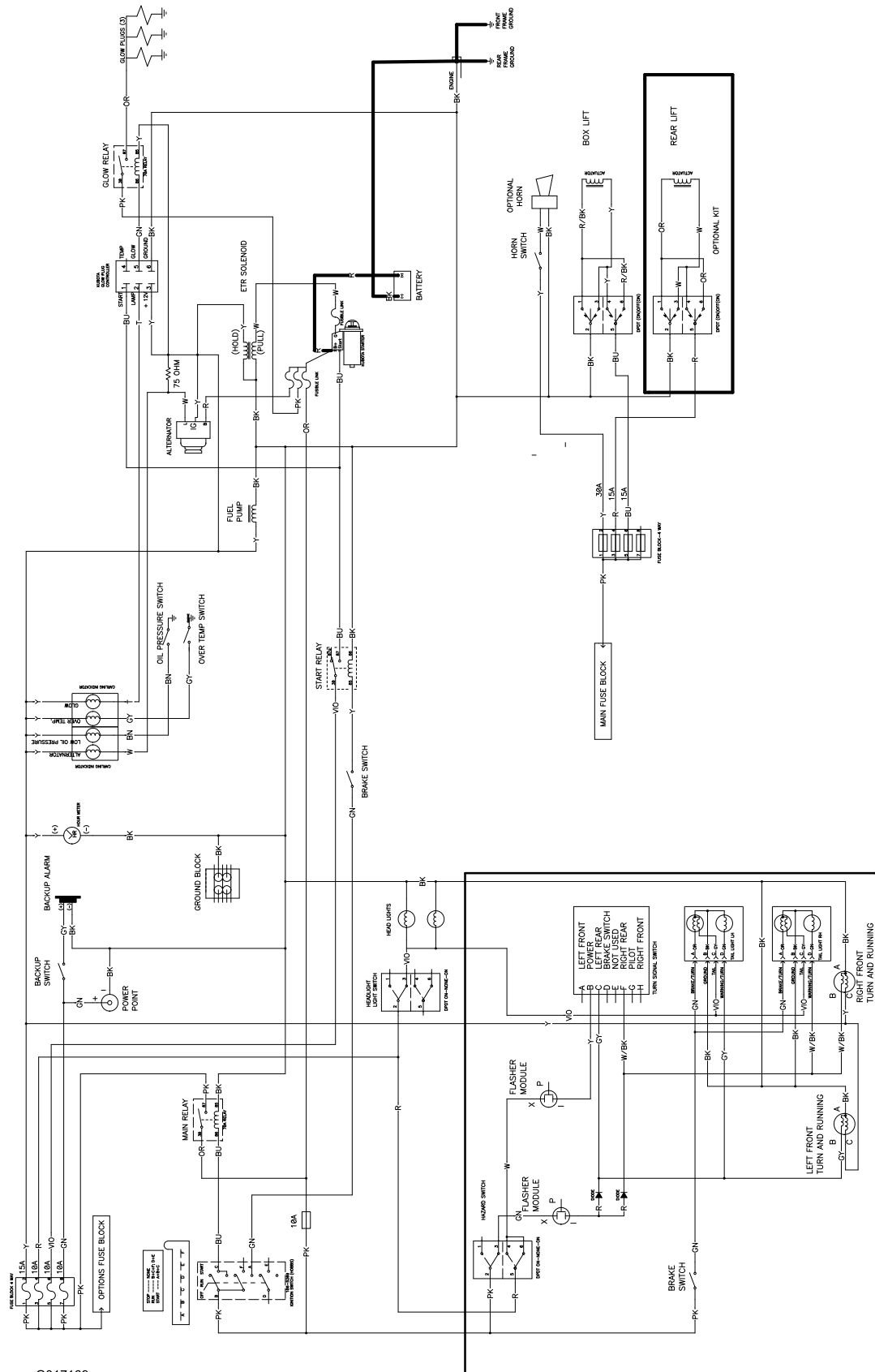

G017169

Electrical Schematic (Rev. A)

Notes:

Notes:

Notes:



The Toro Total Coverage Guarantee

A Limited Warranty

Conditions and Products Covered

The Toro® Company and its affiliate, Toro Warranty Company, pursuant to an agreement between them, jointly warrant your Toro Commercial product ("Product") to be free from defects in materials or workmanship for two years or 1500 operational hours*, whichever occurs first. This warranty is applicable to all products with the exception of Aerators (refer to separate warranty statements for these products). Where a warrantable condition exists, we will repair the Product at no cost to you including diagnostics, labor, parts, and transportation. This warranty begins on the date the Product is delivered to the original retail purchaser.

* Product equipped with an hour meter.

Instructions for Obtaining Warranty Service

You are responsible for notifying the Commercial Products Distributor or Authorized Commercial Products Dealer from whom you purchased the Product as soon as you believe a warrantable condition exists. If you need help locating a Commercial Products Distributor or Authorized Dealer, or if you have questions regarding your warranty rights or responsibilities, you may contact us at:

Commercial Products Service Department
Toro Warranty Company
8111 Lyndale Avenue South
Bloomington, MN 55420-1196
E-mail: commercial.warranty@toro.com

Owner Responsibilities

As the Product owner, you are responsible for required maintenance and adjustments stated in your Operator's Manual. Failure to perform required maintenance and adjustments can be grounds for disallowing a warranty claim.

Items and Conditions Not Covered

Not all product failures or malfunctions that occur during the warranty period are defects in materials or workmanship. This warranty does not cover the following:

- Product failures which result from the use of non-Toro replacement parts, or from installation and use of add-on, or modified non-Toro branded accessories and products. A separate warranty may be provided by the manufacturer of these items.
- Product failures which result from failure to perform recommended maintenance and/or adjustments. Failure to properly maintain your Toro product per the Recommended Maintenance listed in the *Operator's Manual* can result in claims for warranty being denied.
- Product failures which result from operating the Product in an abusive, negligent or reckless manner.
- Parts subject to consumption through use unless found to be defective. Examples of parts which are consumed, or used up, during normal Product operation include, but are not limited to, brakes pads and linings, clutch linings, blades, reels, bed knives, tines, spark plugs, castor wheels, tires, filters, belts, and certain sprayer components such as diaphragms, nozzles, and check valves, etc.
- Failures caused by outside influence. Items considered to be outside influence include, but are not limited to, weather, storage practices, contamination, use of unapproved coolants, lubricants, additives, fertilizers, water, or chemicals, etc.
- Normal noise, vibration, wear and tear, and deterioration.
- Normal "wear and tear" includes, but is not limited to, damage to seats due to wear or abrasion, worn painted surfaces, scratched decals or windows, etc.

Countries Other than the United States or Canada

Customers who have purchased Toro products exported from the United States or Canada should contact their Toro Distributor (Dealer) to obtain guarantee policies for your country, province, or state. If for any reason you are dissatisfied with your Distributor's service or have difficulty obtaining guarantee information, contact the Toro importer. If all other remedies fail, you may contact us at Toro Warranty Company.

Parts

Parts scheduled for replacement as required maintenance are warranted for the period of time up to the scheduled replacement time for that part. Parts replaced under this warranty are covered for the duration of the original product warranty and become the property of Toro. Toro will make the final decision whether to repair any existing part or assembly or replace it. Toro may use remanufactured parts for warranty repairs.

Note Regarding Deep Cycle Battery Warranty:

Deep cycle batteries have a specified total number of kilowatt-hours they can deliver during their lifetime. Operating, recharging, and maintenance techniques can extend or reduce total battery life. As the batteries in this product are consumed, the amount of useful work between charging intervals will slowly decrease until the battery is completely worn out. Replacement of worn out batteries, due to normal consumption, is the responsibility of the product owner. Battery replacement may be required during the normal product warranty period at owner's expense.

Maintenance is at Owner's Expense

Engine tune-up, lubrication cleaning and polishing, replacement of Items and Conditions Not Covered filters, coolant, and completing Recommended Maintenance are some of the normal services Toro products require that are at the owner's expense.

General Conditions

Repair by an Authorized Toro Distributor or Dealer is your sole remedy under this warranty.

Neither The Toro Company nor Toro Warranty Company is liable for indirect, incidental or consequential damages in connection with the use of the Toro Products covered by this warranty, including any cost or expense of providing substitute equipment or service during reasonable periods of malfunction or non-use pending completion of repairs under this warranty. Except for the Emissions warranty referenced below, if applicable, there is no other express warranty.

All implied warranties of merchantability and fitness for use are limited to the duration of this express warranty. Some states do not allow exclusions of incidental or consequential damages, or limitations on how long an implied warranty lasts, so the above exclusions and limitations may not apply to you.

This warranty gives you specific legal rights, and you may also have other rights which vary from state to state.

Note regarding engine warranty:

The Emissions Control System on your Product may be covered by a separate warranty meeting requirements established by the U.S. Environmental Protection Agency (EPA) and/or the California Air Resources Board (CARB). The hour limitations set forth above do not apply to the Emissions Control System Warranty. Refer to the Engine Emission Control Warranty Statement printed in your *Operator's Manual* or contained in the engine manufacturer's documentation for details