



Count on it.

Operator's Manual

SGR-6 Stump Grinder

Model No. 22610—Serial No. 311000001 and Up

Model No. 22610G—Serial No. 311000001 and Up

Model No. 32610—Serial No. 312000001 and Up

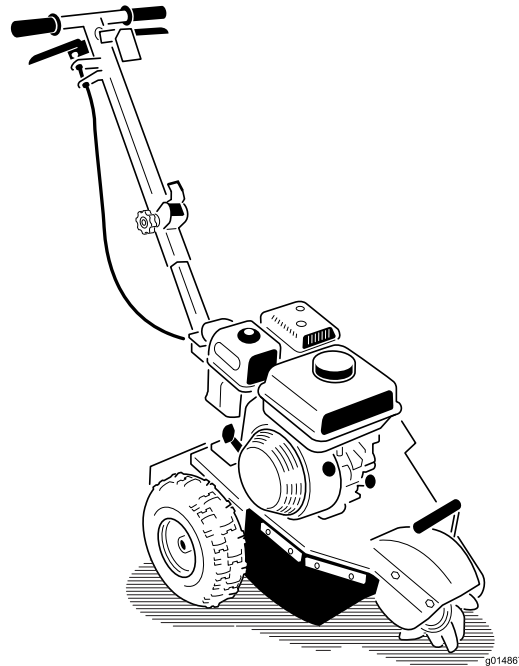

WARNING

CALIFORNIA Proposition 65 Warning

The engine exhaust from this product contains chemicals known to the State of California to cause cancer, birth defects, or other reproductive harm.

▲ DANGER

There may be buried power, gas, and/or telephone lines in the work area. Shock or explosion may occur if you dig into them.

Have the property or work area marked for buried lines and do not dig in marked areas. Contact your local marking service or utility company to have the property marked (for example, in the United States, call 811 for the nationwide marking service).

This spark ignition system complies with Canadian ICES-002.

Because in some areas there are local, state, or federal regulations requiring that a spark arrester be used on the engine of this machine, a spark arrester is available as an option. If you require a spark arrester, contact your Authorized Toro Service Dealer.

Genuine Toro spark arresters are approved by the USDA Forestry Service.

Important: It is a violation of California Public Resource Code Section 4442 to use or operate the engine on any forest-covered, brush-covered, or grass-covered land without a spark arrester muffler maintained in working order, or the engine constricted, equipped, and maintained for the prevention of fire. Other states or federal areas may have similar laws.

The enclosed *Engine Owner's Manual* is supplied for information regarding the US Environmental Protection Agency (EPA) and the California Emission Control Regulation of emission systems, maintenance, and warranty. Replacements may be ordered through the engine manufacturer.

Introduction

This machine is designed to grind and remove tree stumps and surface roots. It is not intended to cut rock or any other material other than wood and the soil around a stump.

Read this information carefully to learn how to operate and maintain your product properly and to avoid injury and product damage. You are responsible for operating the product properly and safely.

You may contact Toro directly at www.Toro.com for product and accessory information, help finding a dealer, or to register your product.

Whenever you need service, genuine Toro parts, or additional information, contact an Authorized Service Dealer or Toro Customer Service and have the model and serial numbers of your product ready. [Figure 1](#) illustrates the location of the model and serial numbers on the product. Write the numbers in the space provided.

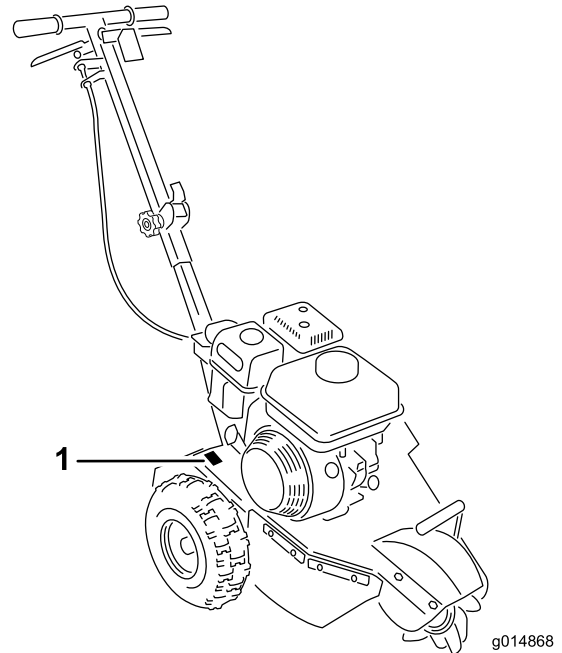

Figure 1

1. Model and serial number plate

Model No. _____

Serial No. _____

This manual identifies potential hazards and has safety messages identified by the safety alert symbol ([Figure 2](#)), which signals a hazard that may cause serious injury or death if you do not follow the recommended precautions.



Figure 2

1. Safety alert symbol

This manual uses 2 other words to highlight information. **Important** calls attention to special mechanical information and **Note** emphasizes general information worthy of special attention.

Contents

Safety	3
Safe Operating Practices	3
Safety and Instructional Decals	5
Product Overview	6
Controls	6
Specifications	7
Attachments/Accessories	7
Operation	8
Before you Start	8
Adding Fuel	8
Checking the Engine Oil Level	9
Starting and Stopping the Engine	10
Grinding a Stump	10
Maintenance	12
Recommended Maintenance Schedule(s)	12
Lubrication	12
Greasing the Machine	12
Engine Maintenance	13
Servicing the Air Cleaner	13
Servicing the Engine Oil	14
Servicing the Spark Plug	15
Belt Maintenance	16
Checking the Drive Belt Tension	16
Adjusting the Drive Belt	16
Grinder Maintenance	17
Checking the Cutting Wheel Blades	17
Replacing the Cutting Wheel Blades	17
Cleaning	18
Removing Debris from the Machine	18
Storage	18
.....	18
Troubleshooting	19

Safety

Improper use or maintenance by the operator or owner can result in injury. To reduce the potential for injury, comply with these safety instructions and always pay attention to the safety alert symbol , which means: **Caution**, **Warning**, or **Danger**—personal safety instruction. Failure to comply with the instruction may result in personal injury or death.

Safe Operating Practices

This product is capable of amputating hands and feet. Always follow all safety instructions to avoid serious injury or death.

WARNING

Engine exhaust contains carbon monoxide, an odorless, deadly poison that can kill you.

Do not run the engine indoors or in an enclosed area.

Training

- Read the *Operator's Manual* and other training material. If the operator(s) or mechanic(s) can not read English, it is the owner's responsibility to explain this material to them.
- Become familiar with the safe operation of the equipment, operator controls, and safety signs.
- All operators and mechanics should be trained. The owner is responsible for training the users.
- Never let children or untrained people operate or service the equipment. Local regulations may restrict the age of the operator.
- The owner/user can prevent and is responsible for accidents or injuries occurring to himself or herself, other people or property.

Preparation

- Evaluate the terrain to determine what accessories and attachments are needed to properly and safely perform the job. Only use accessories and attachments approved by the manufacturer.
- Wear appropriate clothing including hard hat, face shield, safety glasses, long pants, safety shoes, and hearing protection. Long hair, loose clothing or jewelry may get tangled in moving parts.
- Inspect the area where the equipment is to be used and remove all objects such as rocks, toys, and wire which can be thrown by the machine.
- Use extra care when handling gasoline and other fuels. They are flammable and vapors are explosive.
 - Use only an approved container
 - Never remove the gas cap or add fuel with the engine running. Allow the engine to cool before refueling. Do not smoke.

- Never refuel or drain the machine indoors.
- Check that the operator presence controls, safety switches, and shields are attached and functioning properly. Do not operate unless they are functioning properly.
- Check that the cutting wheel has stopped rotating when you reduce the throttle.

Operation

- Never run an engine in an enclosed area.
- Only operate in good light, keeping away from holes and hidden hazards.
- Be sure all drives are in neutral before starting the engine. Only start the engine from the operator's position.
- Never operate with the guards not securely in place. Be sure all interlocks are attached, adjusted properly, and functioning properly.
- Do not change the engine governor setting or overspeed the engine.
- Stop on level ground, lower the grinder, and shut off the engine before leaving the operator's position for any reason.
- Keep hands and feet away from the moving grinder wheel and teeth.
- Look behind and down before backing up to be sure of a clear path.
- Keep pets and bystanders away.
- Do not operate the machine under the influence of alcohol or drugs.
- Use care when loading or unloading the machine into a trailer or truck.
- Ensure that the area is clear of other people before operating the machine. Stop the machine if anyone enters the area.
- Never leave a running machine unattended. Always stop the engine and verify the cutting wheels has stopped rotating.
- Never jerk the controls; use a steady motion.
- Watch for traffic when operating near or crossing roadways.
- Do not touch parts which may be hot from operation. Allow them to cool before attempting to maintain, adjust, or service.
- Ensure that you operate the machine in areas where there are no obstacles in close proximity to the operator. Failure to maintain adequate distance from trees, walls, and other barriers may result in injury as the machine backs up during operation if the operator is not attentive to the surroundings. Only operate the unit in areas where there is sufficient clearance for the operator to safely maneuver the product.
- Before grinding, have the area marked for underground utilities, and do not grind in marked areas.

- Locate the pinch point areas marked on the machine and keep hands and feet away from these areas.
- Lightning can cause severe injury or death. If lightning is seen or thunder is heard in the area, do not operate the machine; seek shelter.

Maintenance and Storage

- Stop the engine. Wait for all movement to stop before adjusting, cleaning, or repairing.
- Clean debris from the grinder, drives, mufflers, and engine to help prevent fires. Clean up oil or fuel spillage.
- Let the engine cool before storing and do not store near flame.
- Do not store fuel near flames or drain indoors.
- Park the machine on level ground. Never allow untrained personnel to service the machine.
- Carefully release pressure from components with stored energy.
- Remove the spark plug wire before making any repairs.
- Keep hands and feet away from moving parts. If possible, do not make adjustments with the engine running.
- Keep all parts in good working condition and all hardware tightened. Replace all worn or damaged decals.
- Keep nuts and bolts tight. Keep equipment in good condition.
- Never tamper with safety devices.
- Keep the machine free of grass, leaves, or other debris build-up. Clean up oil or fuel spillage. Allow the machine to cool before storing.
- Use extra care when handling gasoline and other fuels. They are flammable and vapors are explosive.
 - Use only an approved container.
 - Never remove the gas cap or add fuel when the engine is running. Allow the engine to cool before refueling. Do not smoke.
 - Never refuel the machine indoors.
 - Never store the machine or fuel container inside where there is an open flame, such as near a water heater or furnace.
 - Never fill a container while it is inside a vehicle, trunk, pick-up bed, or any surface other than the ground.
 - Keep container nozzle in contact with the tank during filling.
- Stop and inspect the equipment if you strike an object. Make any necessary repairs before restarting.
- Use only genuine Toro replacement parts to ensure that original standards are maintained.

Safety and Instructional Decals



Safety decals and instructions are easily visible to the operator and are located near any area of potential danger. Replace any decal that is damaged or lost.

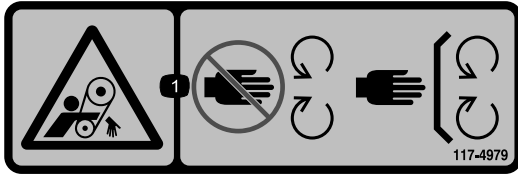

117-4979

1. Entanglement hazard, belt—stay away from moving parts, keep all guards and shields in place.



119-4693

1. Thrown object hazard—keep bystanders a safe distance from the machine.

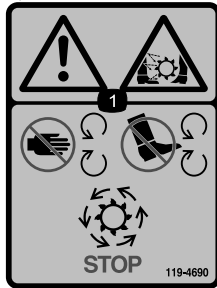

119-4690

1. Warning; cutting/dismemberment hazard, grinding blade—keep hands and feet away from all moving parts, keep all shields in place; wait for all moving parts to stop.

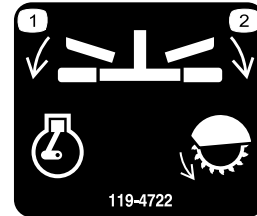

119-4722

1. Engine—run
2. Grinder blade—engage



119-4691

1. Warning—read the *Operator's Manual*; wait for grinder blade to stop, stop the engine and fold the handle.

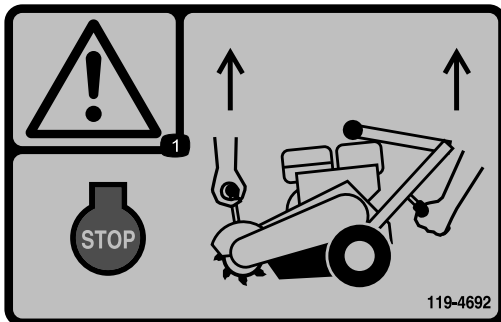

119-4692

1. Warning—stop the engine; use both hand holds to lift the grinder.

Product Overview

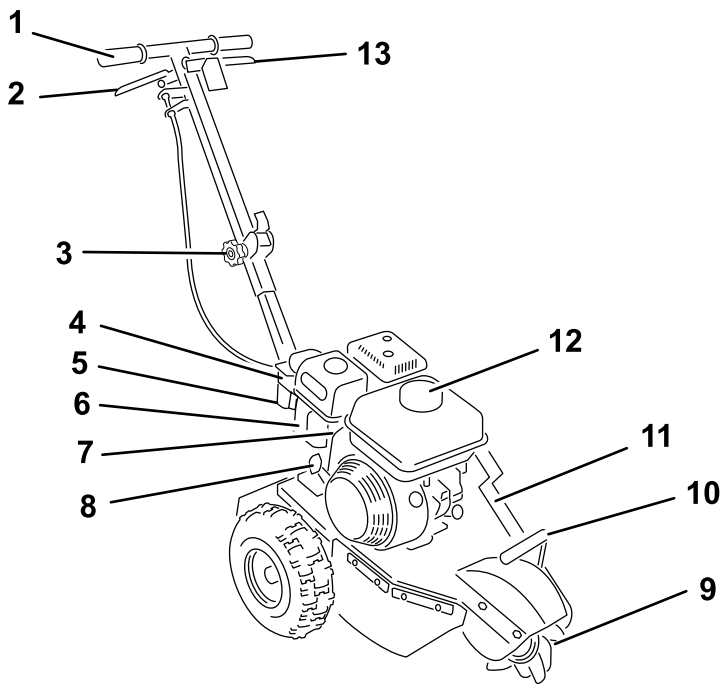

g014869

Figure 3

- | | |
|------------------------|------------------|
| 1. Handle | 8. Starter |
| 2. Throttle lever | 9. Cutting wheel |
| 3. Handle release knob | 10. Lift |
| 4. Air filter | 11. Belt cover |
| 5. Sediment cup | 12. Fuel cap |
| 6. Fuel valve | 13. Safety bail |
| 7. Choke | |

Controls

Become familiar with all the controls ([Figure 3](#) and [Figure 6](#)) before you start the engine and operate the machine.

Handle Release Knob

The handle on this machine has the capability to be folded down for easier transport. Unscrew the handle release knob from the machine ([Figure 4](#)).

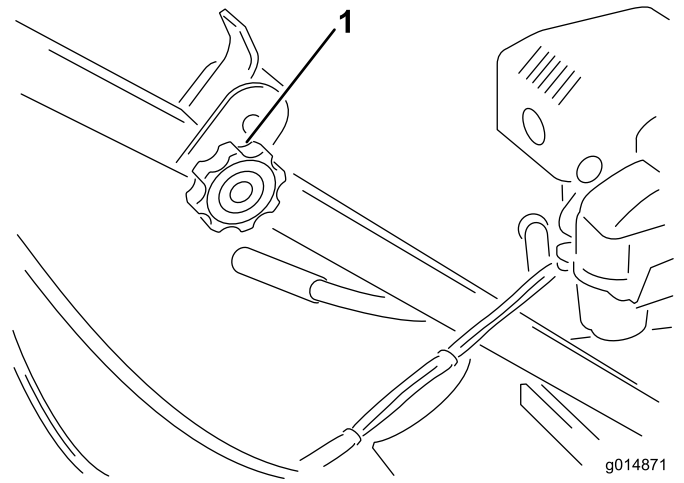

g014871

Figure 4

1. Handle Release Knob

Fold the handle down toward the machine and screw the knob back onto the handle ([Figure 5](#)).

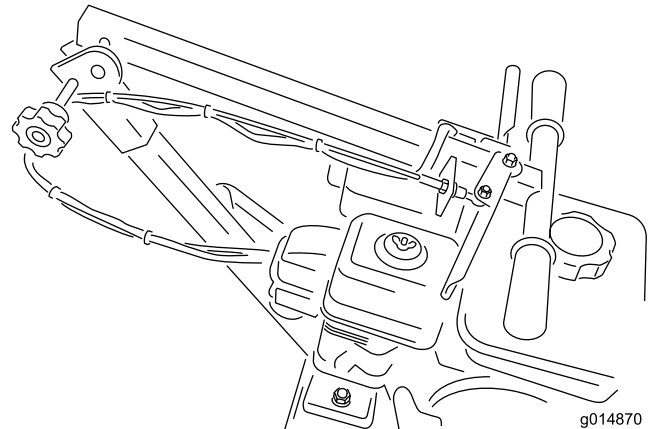

g014870

Figure 5

Throttle Lever and Safety Bail

The throttle lever controls the engine speed. With the lever released, in the disengaged position, the engine runs at idle. This is also the starting position. When you pull the lever to the handle, the engine speed increases, the centrifugal clutch engages, and the cutting wheel rotates.

The safety bail controls the engine. Hold the safety bail against the handle to deactivate the engine kill switch so that the engine will start. Release the safety bail to stop the engine.

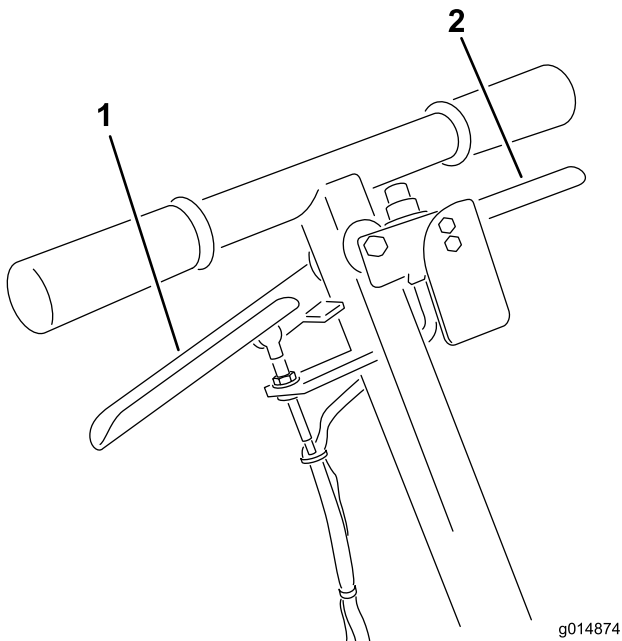
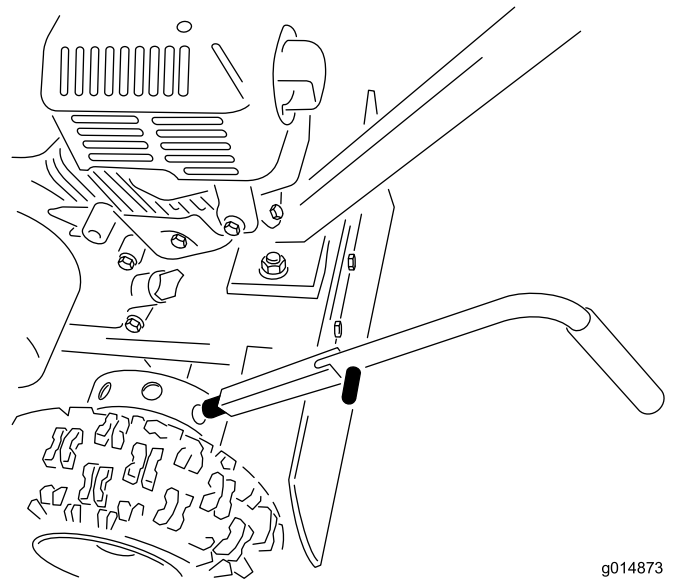

Figure 6

g014874

1. Throttle lever

2. Safety bail



g014873

Figure 8

1. Disengaged Brake

Parking Brake

The parking brake (Figure 6 and Figure 7) holds the left wheel from turning to secure the machine and for easy movement of the machine from side to side when grinding astump.

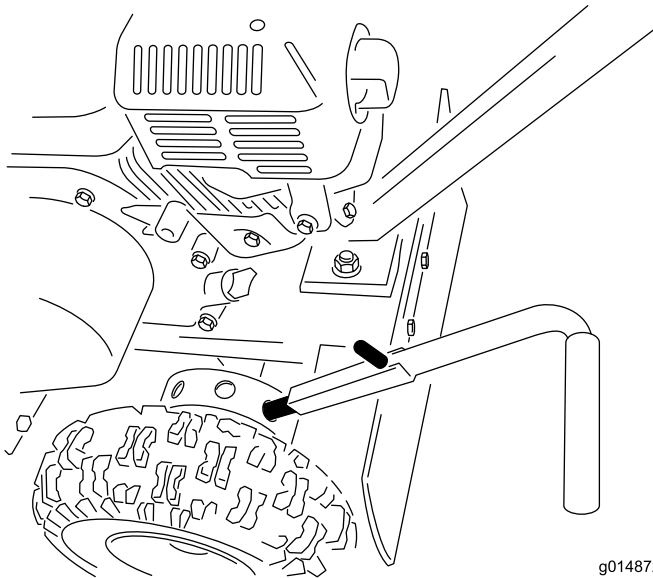

g014872

Figure 7

1. Engaged brake

Specifications

Note: Specifications and design are subject to change without notice.

Cutting Depth	Approx 12 inches (30.48 cm)
Length	50 inches (127 cm)
Width	22 inches (56 cm)
Height	42 inches (107 cm)
Weight	103 lbs (47 Kg)

Attachments/Accessories

A selection of Toro approved attachments and accessories is available for use with the machine to enhance and expand its capabilities. Contact your Authorized Service Dealer or Distributor or go to www.Toro.com for a list of all approved attachments and accessories.

Operation

Note: Determine the left and right sides of the machine from the normal operating position.

Important: Before operating, check the fuel and oil level, and remove debris from the machine. Also, ensure that the area is clear of people and debris. You should also know and have marked the locations of all utility lines.

Before you Start

- Dig away the earth and remove any stones near the tree stump that may interfere with your work. Check that the ground is free of foreign objects, such as electrical cables, barbed wire, etc.
- Cut or trim the stump using a power saw.
- Review all the machine's safety decals.
- Use a hard-hat, hearing, and eye protection. A mesh visor alone does not provide sufficient eye protection; supplement with protective glasses.
- Ensure that you are familiar with safety regulations and shutdown procedures described in the *Operator's Manual*.
- Ensure that all guards are in place and in good condition.
- Ensure that the blades and cutters are in place and in good condition.
- Ensure that the work area, cutter, and stump in particular are free from metallic objects such as wire, nails, etc. that could be thrown out and injure persons in the vicinity and damage the equipment.
- Ensure that everyone, including children and animals, maintain a distance of at least 50 feet (15 m) from the machine. Debris can be thrown out and injure people and animals.

Adding Fuel

Use unleaded gasoline (87 pump octane minimum). Leaded, regular gasoline may be used if unleaded is not available.

⚠ DANGER

In certain conditions, gasoline is extremely flammable and highly explosive. A fire or explosion from gasoline can burn you and others and can damage property.

- Fill the fuel tank outdoors, in an open area, when the engine is cold. Wipe up any gasoline that spills.
- Never fill the fuel tank inside an enclosed trailer.
- Do not fill the fuel tank completely full. Add gasoline to the fuel tank until the level is 1/4 to 1/2 inch (6 to 13 mm) below the bottom of the filler neck. This empty space in the tank allows gasoline to expand.
- Never smoke when handling gasoline, and stay away from an open flame or where gasoline fumes may be ignited by a spark.
- Store gasoline in an approved container and keep it out of the reach of children. Never buy more than a 30-day supply of gasoline.
- Do not operate without entire exhaust system in place and in proper working condition.

⚠ DANGER

In certain conditions during fueling, static electricity can be released causing a spark which can ignite the gasoline vapors. A fire or explosion from gasoline can burn you and others and can damage property.

- Always place gasoline containers on the ground away from your vehicle before filling.
- Do not fill gasoline containers inside a vehicle or on a truck or trailer bed because interior carpets or plastic truck bed liners may insulate the container and slow the loss of any static charge.
- When practical, remove gas-powered equipment from the truck or trailer and refuel the equipment with its wheels on the ground.
- If this is not possible, then refuel such equipment on a truck or trailer from a portable container, rather than from a gasoline dispenser nozzle.
- If a gasoline dispenser nozzle must be used, keep the nozzle in contact with the rim of the fuel tank or container opening at all times until fueling is complete.

Important: Do not use methanol, gasoline containing methanol, or gasohol containing more than 10% ethanol

because the fuel system could be damaged. Do not mix oil with gasoline.

Using Stabilizer/Conditioner

Use a fuel stabilizer/conditioner in the machine to provide the following benefits:

- Keeps gasoline fresh during storage of 90 days or less. For longer storage it is recommended that the fuel tank be drained.
- Cleans the engine while it runs.
- Eliminates gum-like varnish buildup in the fuel system, which causes hard starting.

Important: Do not use fuel additives containing methanol or ethanol.

Add the correct amount of gas stabilizer/conditioner to the gas.

Note: A fuel stabilizer/conditioner is most effective when mixed with fresh gasoline. To minimize the chance of varnish deposits in the fuel system, use fuel stabilizer at all times.

Filling the Fuel Tank

1. Park the machine on a level surface, lower the grinder, and stop the engine.
2. Allow the engine to cool.
3. Clean around the fuel tank cap and remove it (Figure 9).

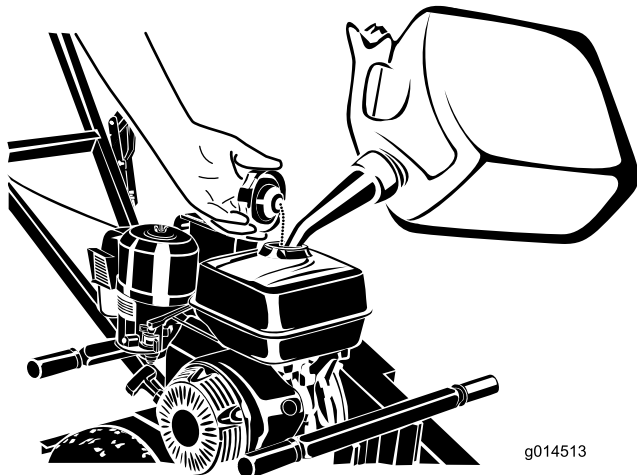

Figure 9

view may vary depending on model

1. Fuel tank cap

4. Add unleaded gasoline to the fuel tank, until the level is 1/4 to 1/2 inch below the bottom of the filler neck.

Important: This space in the tank allows gasoline to expand. Do not fill the fuel tank completely full.

5. Install the fuel tank cap securely.

6. Wipe up any gasoline that may have spilled.

Checking the Engine Oil Level

Service Interval: Before each use or daily

1. Tilt the machine so the engine is level, and stop the engine.
2. Allow the engine to cool.
3. Clean around the oil dipstick.
4. Remove the dipstick and wipe the end clean.
5. Slide the dipstick fully into the dipstick tube without threading it into the filler neck.
6. Pull the dipstick out and look at the end. The oil should be to the top of the upper limit range (Figure 10).

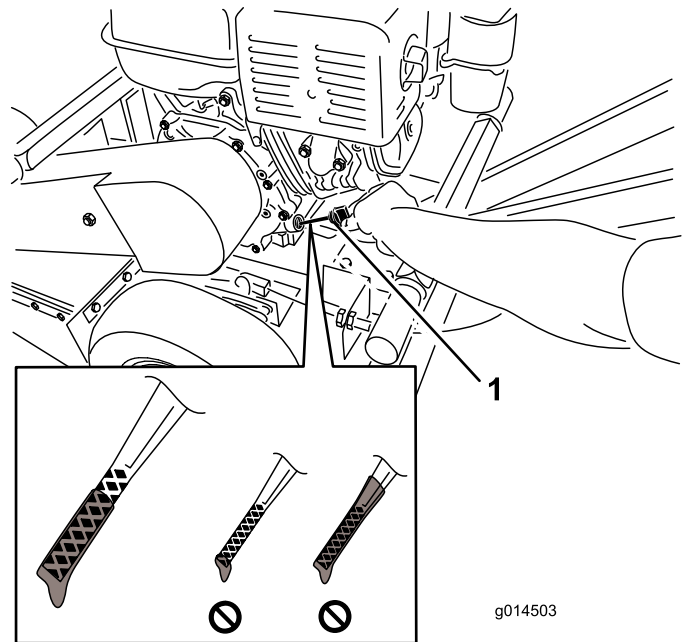

Figure 10

1. Oil dipstick

Important: Running the engine with low oil level can cause engine damage. This type of damage is not covered by warranty.

The engine is equipped with an oil alert system that will automatically stop the engine before the oil level falls below the safe limit.

7. If the oil level is low, slowly pour only enough oil into the crankcase to raise the level to the upper limit.

Important: Do not overfill the crankcase with oil because the engine may be damaged.

8. Replace the dipstick.

Starting and Stopping the Engine

Starting the Engine

1. Move the fuel valve to the Open position, all the way to the right (Figure 11).

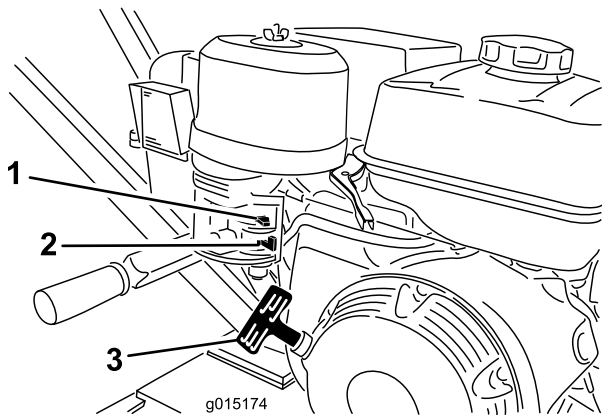

Figure 11

1. Choke
2. Fuel valve
3. Starter

2. Move the choke lever left to the On position if you are starting a cold engine.

Note: A warm or hot engine may not require choking.

3. Hold the safety bail against the handle and push the handle down enough to raise the cutting wheel off the ground.
4. Pull the starter handle lightly until you feel resistance, then pull the handle briskly. Return the starter handle gently (Figure 11).
5. After the engine starts, gradually move the choke lever back to the Off position. If the engine stalls or hesitates, move the choke back to On again until the engine warms up. Then move it to the Off position.
6. Hold the throttle lever against the handle to spin the cutting wheel.

Stopping the Engine

1. Release your hand from the throttle lever.

Note: If the engine has been working hard or is hot, let it run for a minute before releasing the safety bail. This helps to cool the engine before stopping. In an emergency, the engine may be stopped immediately.

2. Release the safety bail to stop the engine.
3. Move the fuel valve to the Closed position, all the way to the left.

Grinding a Stump

Place the machine into position with the cutting wheel near the front-top edge of the stump.

⚠ DANGER

The machine will cut and amputate hands and feet.

- Stay in the operator's position while the machine is running and keep away from the cutting wheel.
- Keep all bystanders a safe distance from the machine.
- Stop the machine immediately if any people or animals enter the work area.

⚠ WARNING

Grinding a stump will throw wood chips, soil, and other debris into the air which could injure you or bystanders.

- Always wear eye protection when using the machine.
 - Keep all bystanders a safe distance from the machine.
1. Release the throttle so that it is in Disengaged position.
 2. Start the engine; refer to [Starting the Engine \(page 10\)](#).
 3. Allow engine to warm up at idle for two minutes.
 4. Push the handle down enough to raise the cutting wheel off the ground.
 5. Hold the throttle against the handle so that it is in engaged position, this will engage the centrifugal clutch and the cutting wheel rotates.
 6. Move the machine to the front of the stump and set the parking brake.
 7. Swing the cutting wheel to one side, then lower it approximately 1/2 inch to 1 inch into the front-top corner of the stump. Swing the cutting wheel back and forth, lowering the cutting wheel approximately 1/2 inch to 1 inch before each sweep, until you have ground the front portion of the stump to ground level (Figure 12).

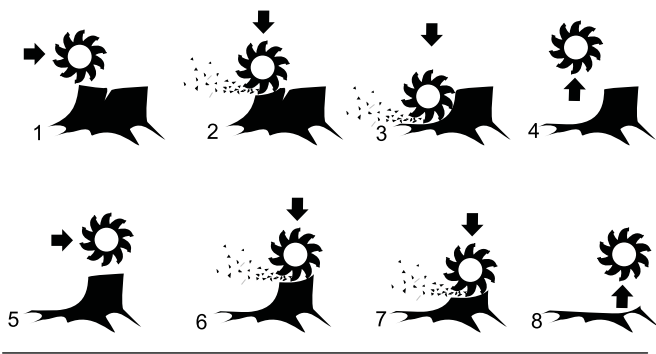

Figure 12

⚠ DANGER

A rotating cutting wheel is very dangerous and can cut and amputate hands and feet.

Stay at the operating position and be sure that the cutting wheel has come to a complete stop before doing anything else.

8. Raise the cutting wheel until center of cutting wheel is just above top of the stump.
9. With the cutting wheel off to one side, release the parking brake and advance the machine forward, reset the parking brake.
10. Continue sweeping and cutting wheel left and right across stump, advancing the machine before each sweep, cutting 1/2 inch to 1 inch depth of cut with each sweep.
11. Continue cutting until top level of stump is all removed, making sure not to cut stump deeper than ground level during this first stage.
12. Release the throttle so that it is in Disengaged position, push the handle down enough to raise the cutting wheel off the ground. Wait ten seconds for the cutting wheel to stop rotating then release the brake and pull the machine away from the stump.
13. Rake the chips away from the stump.
14. Move the machine to the front of the stump and set the parking brake.
15. Hold the throttle against the handle so that it is in engaged position, this will engage the centrifugal clutch and the cutting wheel rotates.
16. Continue cutting until the level of stump is deeper than ground level as desired.
17. Stop the machine; refer to [Stopping the Engine \(page 10\)](#).

Note: Do not let the front of the unit touch the ground until you are sure the cutting wheel has stopped turning.

Maintenance

Note: Determine the left and right sides of the machine from the normal operating position.

Important: The machine may be tipped backward or on its side to facilitate access for cleaning or service, but no longer than 2 minutes. If the machine is held in this position for too long, the engine can be damaged by gasoline draining into the crankcase. Should this happen, perform an extra oil change on the engine. Then turn the engine over a few revolutions with the starter handle before starting the engine again.

Recommended Maintenance Schedule(s)

Maintenance Service Interval	Maintenance Procedure
After the first 25 hours	<ul style="list-style-type: none">• Change the oil.
Before each use or daily	<ul style="list-style-type: none">• Check the engine oil level.• Grease the machine.• Check the air filter.• Check the cutting wheel blades.• Remove debris from the machine.
Every 25 hours	<ul style="list-style-type: none">• Check the drive belt tension.
Every 50 hours	<ul style="list-style-type: none">• Service the air filter.
Every 100 hours	<ul style="list-style-type: none">• Change the oil.• Clean the sediment cup.• Check the spark plugs.
Every 200 hours	<ul style="list-style-type: none">• Replace the air filter.
Yearly or before storage	<ul style="list-style-type: none">• Change the oil.• Clean the sediment cup.

Important: Refer to your *Engine Operator's Manual* for additional maintenance procedures.

Lubrication

Greasing the Machine

Service Interval: Before each use or daily

Grease Type: General-purpose grease.

1. Clean the grease fittings with a rag.
2. Connect a grease gun to each fitting.
3. Lubricate two fittings, one on each cutting wheel bearing.

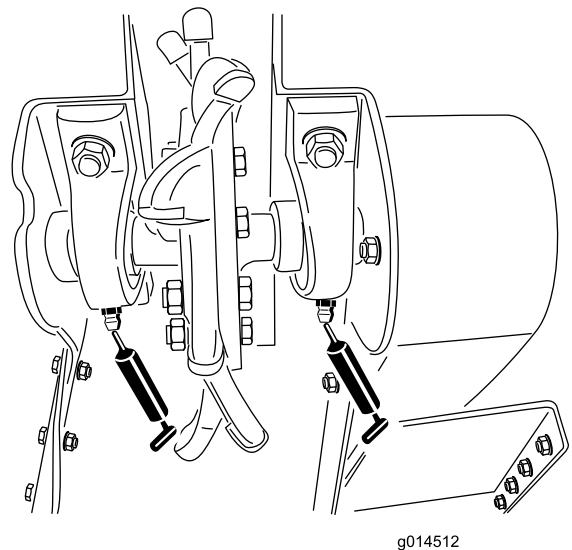

Figure 13

4. Pump grease into the fittings until grease begins to ooze out of the bearings (approximately 3 pumps).
5. Wipe up any excess grease.

Important: Pump grease in slowly and carefully to prevent damage to the bearing seals.

Engine Maintenance

Servicing the Air Cleaner

Service Interval: Before each use or daily

The cyclone air filter collects the largest contaminant particles, which collect in the container. When you can see a layer of dirt at the bottom of the container, clean the cyclone housing, air channels, and air intake screen.

Servicing the Cyclone Air Filter

Service Interval: Every 50 hours

1. Remove the 3 screws holding the cyclone housing.
2. Remove the housing with the air intake screen and remove the air channels.

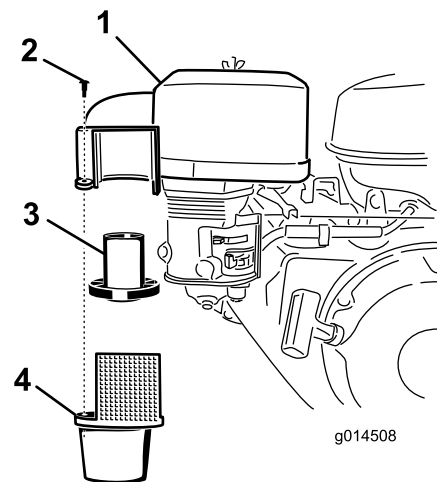

Figure 14

- | | |
|--------------------|---|
| 1. Cyclone housing | 3. Air channels |
| 2. Screw | 4. Cyclone housing with air intake screen |

Note: The air channels may remain in the upper portion or follow along with the housing when removed.

3. Clean the components. Use water, detergent and a brush. Dry carefully.
4. Place the air channels in the cyclone housing.
5. Insert cyclone housing into position and make sure it fits in the upper portion. **Do not** use force; align it in place before fitting the screws.

Replacing the Air Filter

Service Interval: Every 200 hours

If the engine is low on power, produces black smoke or runs unevenly, the air filter may be clogged.

1. Remove the wing nut and lift off the cyclone filter with the air filter cowling (Figure 15).

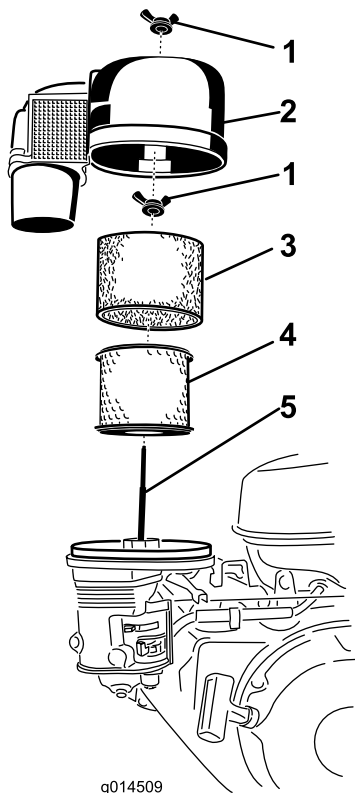

g014509

Figure 15

- | | |
|-----------------------|---------------|
| 1. Wing nut | 4. Air filter |
| 2. Cyclone air filter | 5. Stud |
| 3. Foam pre-filter | |

2. Remove the foam pre-filter and clean it as follows
 - A. Wash the pre-filter using a mild detergent and water.
 - B. Squeeze it dry with a clean cloth.
 - C. Soak it with new engine oil.
 - D. Gently wind the filter in an absorbent cloth and squeeze out excess oil.
3. Remove the wing nut on top of the air filter and remove the paper filter.
4. Tap the paper filter against a fixed surface to remove dust. If the paper filter is still dirty or damaged, replace it. The paper filter should be replaced every 200 hours.

Important: Do not use compressed air to blow out the paper element, this can damage it.

5. Mount the paper filter in the air filter housing and secure it with the wing nut.
6. Position the foam pre-filter over the paper filter.
7. Install the cyclone filter with the air filter cover and secure it with the wing nut.

Servicing the Engine Oil

Note: Change the oil more frequently when the operating conditions are extremely dusty or sandy.

Oil Type: Detergent oil with an API service of SJ or higher.

Crankcase Capacity: .63 qt (.6 liters)

Viscosity: SAE 10W-30 is recommended for general use.

Changing the Engine Oil

Service Interval: After the first 25 hours

Every 100 hours

Yearly or before storage

1. Start the engine and let it run five minutes. This warms the oil so it drains better.
2. Park the machine so that the drain side is slightly lower than the opposite side to ensure that the oil drains completely.
3. Set the parking brake and stop the engine.
4. Place a pan under the oil drain hole.
5. Remove the drain plug and drain the oil through the hole slot in the frame ([Figure 16](#)).

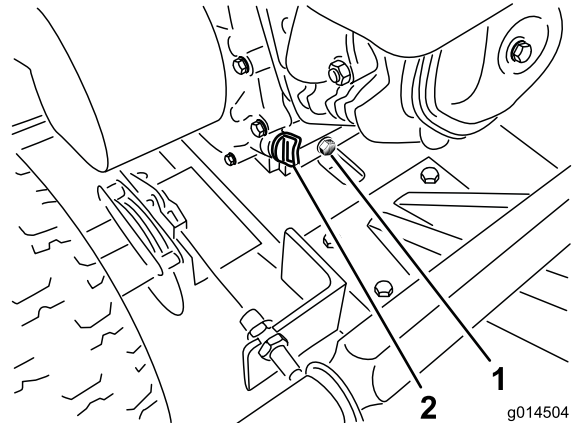

g014504

Figure 16

- | | |
|-------------------|-----------------|
| 1. Oil drain hole | 2. Oil fill cap |
|-------------------|-----------------|

6. When the oil has drained completely, install the plug and wipe up any spilled oil.

Note: Dispose of the used oil at a certified recycling center.

7. Remove the oil fill cap and slowly pour approximately 80 percent of the specified amount of oil into the engine ([Figure 16](#)).
8. Slowly add additional oil to bring the oil level to the upper limit mark on the dipstick. Refer to [Checking the Engine Oil Level](#) (page 9).
9. Install the oil fill cap.

Cleaning the Sediment Cup

Service Interval: Every 100 hours

Yearly or before storage

Underneath the fuel valve is a sediment cup to catch dirt in the fuel.

1. Move the fuel valve to the Off position, all the way to the left.
2. Unscrew the sediment cup. Make sure not to misplace the o-ring (Figure 17).

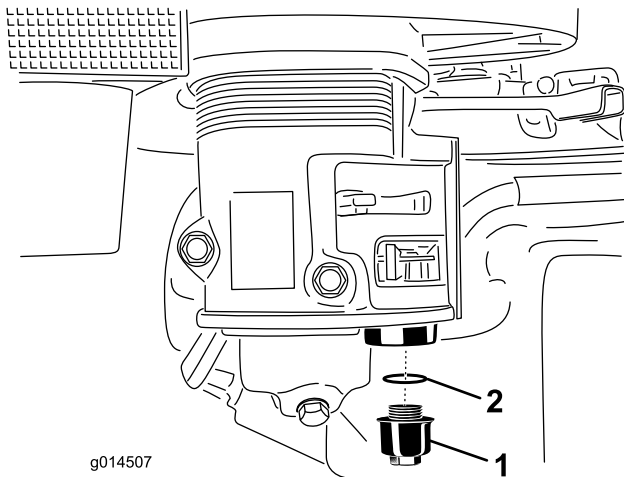

Figure 17

1. Sediment cup
2. O-Ring

3. Clean the reservoir and the o-ring using a cleaning solvent and dry carefully.

Note: Make sure not to misplace the o-ring.

4. Put the o-ring in place in the groove of the cup and replace the sediment cup.
5. Turn the fuel valve to the On position, all the way to the right, and check for leaks. If it leaks, replace the o-ring.

Servicing the Spark Plug

Service Interval: Every 100 hours—Check the spark plugs.

Ensure that the air gap between the center and side electrodes is correct before installing the spark plug. Use a spark plug wrench for removing and installing the spark plug and a gapping tool/feeler gauge to check and adjust the air gap. Install a new spark plug if necessary.

Type: BPR6ES (NKG) or equivalent

Air Gap: 0.28–0.031 inch (0.70-0.80 mm)

Removing the Spark Plug

1. Lower the grinder and stop the machine; Refer to [Stopping the Engine \(page 10\)](#).
2. Pull the wire off of the spark plug (Figure 18).

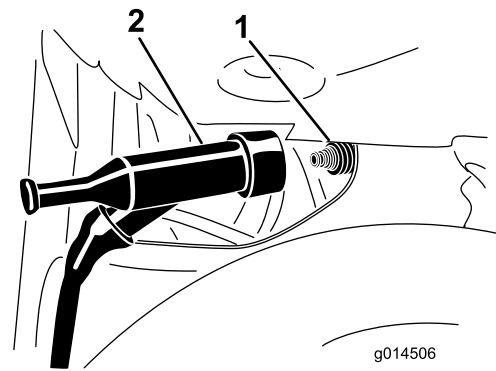

Figure 18

1. Spark plug
2. Wire

3. Clean around the spark plug.
4. Remove the spark plug and the metal washer.

Checking the Spark Plug

1. Look at the center of the spark plug (Figure 19). If you see light brown or gray on the insulator, the engine is operating properly. A black coating on the insulator usually means that the air cleaner is dirty.

Important: Do not clean the spark plug. Always replace the spark plug when it has a black coating, worn electrodes, an oily film, or cracks.

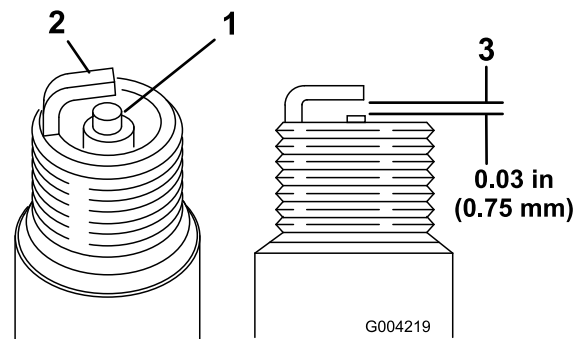

Figure 19

1. Center electrode insulator
2. Side electrode
3. Air gap (not to scale)

2. Check the gap between the center and side electrodes (Figure 19). Bend the side electrode (Figure 19) if the gap is not correct.

Installing the Spark Plug

1. Thread the spark plug into the spark plug hole.
2. Tighten the spark plug to 20 ft-lb (27 N-m).
3. Push the wire onto the spark plug.

Belt Maintenance

Checking the Drive Belt Tension

Service Interval: Every 25 hours

Note: Replace the belt if it shows any signs of wear, cracks, or damage.

1. Shut off the engine and wait for all rotating parts to stop.
2. Remove belt guard retaining screws (Figure 20).

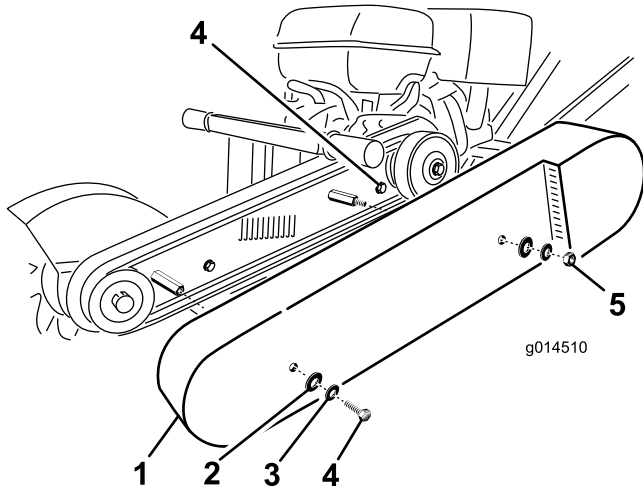

Figure 20

Your model may vary

- | | |
|----------------|---------|
| 1. Belt guard | 4. Bolt |
| 2. Lock washer | 5. Nut |
| 3. Washer | |

3. To check belt tension, gently squeeze the belt spans together. You should be able to push the belt down about 1/4–3/8 inch (6–10mm) from the original position.

Important: To extend the belt life, proper tension must be maintained. A loose belt will cause excessive cutting wheel slippage and early belt failure. A belt that is too tight can cause bearing and shaft failure, and rapid belt wear.

Adjusting the Drive Belt

1. Remove the belt guard.
2. Loosen the 4 engine mounting bolts, and jam nuts holding the adjustment bolt (Figure 21).

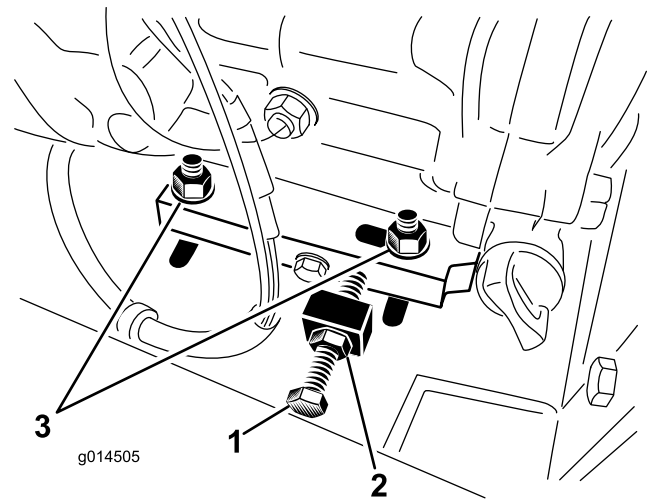

Figure 21

- | | |
|------------|----------------------|
| 1. Bolt | 3. Engine mount bolt |
| 2. Jam Nut | |

3. Turn square head adjusting bolt on the frame clockwise to tighten the belt, counter clockwise to loosen the belt

Important: Important: Make sure to tighten all engine bolts after proper belt adjustment is achieved.

4. Install the belt guard and secure with previously removed hardware.

Grinder Maintenance

Checking the Cutting Wheel Blades

Service Interval: Before each use or daily

Among the most critical elements of the machine is the cutting wheel blades. They are also the most subject to damage and wear. In the course of grinding stumps they not only make contact with the wood, but they also encounter numerous abrasives and objects, such as dirt, stones, and occasionally a large rock or buried scrap.

The wear and loss of cutting teeth can significantly impair the efficiency and performance of the machine. Therefore, it is important to make frequent checks of the condition of all of the cutting teeth and replace any damaged or worn blade sections (Figure 22).

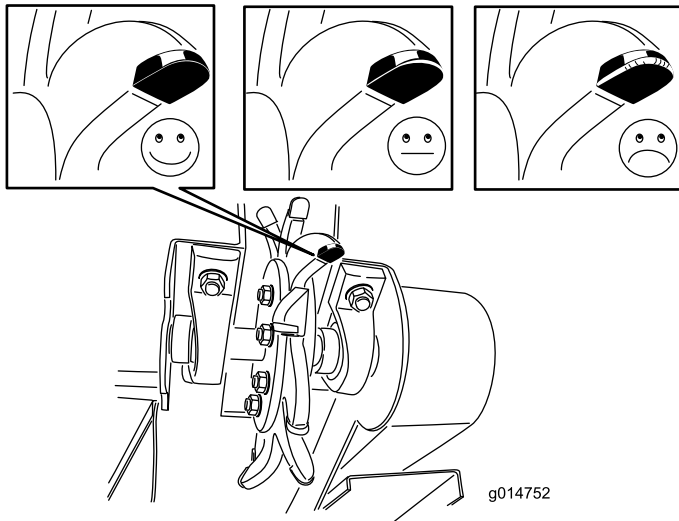

Figure 22

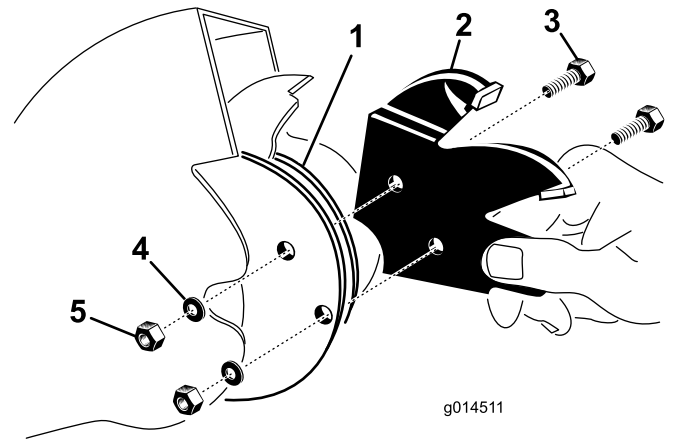

Figure 23

3. Check each section for cracks. Replace a blade section if it is cracked or has missing or worn teeth.

Note: When replacing cutting wheel blade sections, make sure blade section is placed in correct alignment with blade rotation.

4. Insert the blade section between the blade mounting flanges (Figure 23), and secure them with 2 bolts, lockwashers, and nuts.
5. Torque the fasteners to 27–33 ft-lb (37–45 N-m).

Replacing the Cutting Wheel Blades

1. Clean all dirt from the cutting wheel and mounting flanges.
2. Remove the two bolts that hold each cutting blade section. Use care not to let a section drop and chip when they become loose (Figure 23).

Cleaning

Removing Debris from the Machine

Regular cleaning and washing will increase the life span of the machine. Clean the machine directly after use, before the dirt hardens.

Check before cleaning that the fuel tank cap is properly in place to avoid getting water in the tank.

Use care when using a high-pressure sprayer because it can damage warning decals, instruction signs, and the engine

Important: Lubricate the cutting wheel blade bearings after cleaning.

Storage

For storage over 30 days, prepare the unit as follows:

1. Remove dirt and grime from the external parts of the entire unit, especially the engine. Clean dirt and sawdust chips from the outside of the engine cylinder head fins and blower housing.

Important: You can wash the unit with mild detergent and water.

2. Add a petroleum based stabilizer/conditioner to fuel in the tank. Follow mixing instructions from stabilizer manufacturer. (1 oz. per US gallon). **Do not** use an alcohol based stabilizer (ethanol or methanol).

Note: Fuel stabilizer/conditioner is most effective when mixed with fresh gasoline and used at all times.

Important: Do not store stabilizer/conditioned gasoline over 90 days.

3. Run the engine to distribute conditioned fuel through the fuel system (5 minutes).
4. Stop the engine, allow it to cool, and drain the fuel tank using a pump type siphon. Dispose of fuel properly; recycle as per local codes.
5. Start the engine and run it until it stops.
6. Choke the engine.
7. Start and run the engine until it will not start again.
8. Clean the sediment cup; refer to [Cleaning the Sediment Cup \(page 14\)](#).
9. Service the air cleaner; refer to [Servicing the Cyclone Air Filter \(page 13\)](#) and, [Replacing the Air Filter \(page 13\)](#).
10. Change the engine crankcase oil; refer to [Changing the Engine Oil \(page 14\)](#).
11. Remove the spark plug and check the condition; refer to [Servicing the Spark Plug \(page 15\)](#).
12. With the spark plug removed from the engine, pour two tablespoons of engine oil into the spark plug hole.
13. Pull the starter slowly to crank the engine and distribute the oil inside the cylinder.
14. Install the spark plug, but do not install the wire on the spark plug.
15. Grease the cutter wheel bearings; refer to [Greasing the Machine \(page 12\)](#).
16. Check and tighten all bolts, nuts, and screws. Repair or replace any part that is damaged.
17. Paint all scratched or bare metal surfaces. Paint is available from your Authorized Service Dealer.
18. Store the unit in a clean, dry garage or storage area.
19. Cover the unit to protect it and keep it clean.

Troubleshooting

Problem	Possible Cause	Corrective Action
The engine will not start.	<ol style="list-style-type: none"> 1. The engine switch is in the Off position. 2. The fuel shutoff valve is closed. 3. The choke is open. 4. The fuel tank is empty. 5. The spark plug wire is loose or disconnected. 	<ol style="list-style-type: none"> 1. Hold the safety bail against the handle. 2. Open the fuel valve. 3. Close the choke when starting a cold engine. 4. Fill tank with fresh fuel. 5. Check the electrode gap and clean or replace the spark plug.
The engine runs rough.	<ol style="list-style-type: none"> 1. The choke is left on. 2. The air filter is clogged. 3. The fuel line is clogged. 4. There is water or contaminants in the fuel. 5. The spark plugs are worn or have buildup on the electrodes. 	<ol style="list-style-type: none"> 1. Open the choke. 2. Clean or replace the air filter. 3. Clean the sediment cup. 4. Drain and fill the tank with fresh fuel. 5. Check the electrode gap and clean or replace the spark plug.
The belt slips or comes off the pulleys	<ol style="list-style-type: none"> 1. The belt tension is insufficient. 	<ol style="list-style-type: none"> 1. Adjust the belt tension. Reduce the cutting depth.
The cutting wheel does not rotate.	<ol style="list-style-type: none"> 1. The engine speed is insufficient to activate the centrifugal clutch. 2. The belt tension is insufficient. 3. The clutch shoes are worn. 	<ol style="list-style-type: none"> 1. Move the throttle to the Engaged position. 2. Adjust the belt tension. 3. Replace the clutch.
The cutting wheel continues to rotate.	<ol style="list-style-type: none"> 1. The engine speed is excessive. 2. The belt is off of the pulleys or broken. 3. Clutch springs are weak or broken. 	<ol style="list-style-type: none"> 1. Move the throttle to the Disengaged position. 2. Replace the drive belt. 3. Replace the clutch.



Toro Compact Utility Equipment Warranty

A One-Year Limited Warranty

CUE Products

Conditions and Products Covered

The Toro® Company and its affiliate, Toro Warranty Company, pursuant to an agreement between them, jointly warrant your Toro Compact Utility Equipment ("Product") to be free from defects in materials or workmanship. The following time periods apply from the date of purchase:

Products	Warranty Period
Loaders, Trenchers, Stump Grinders, Chippers, Log Splitters and Attachments Kohler Engines	1 year or 1000 operating hours, whichever occurs first
Kohler Engines	3 years
All other Engines	2 years

Where a warrantable condition exists, we will repair the Product at no cost to you including diagnosis, labor, and parts.

Instructions for Obtaining Warranty Service

If you think that your Toro Product contains a defect in materials or workmanship, follow this procedure:

1. Contact any Authorized Toro Compact Utility Equipment (CUE) Service Dealer to arrange service at their dealership. To locate a dealer convenient to you, access our website at www.Toro.com. You may also call our Toro Customer Care Department toll free at 888-865-5676 (U.S. customers) or 888-865-5691 (Canadian customers).
2. Bring the product and your proof of purchase (sales receipt) to the Service Dealer.
3. If for any reason you are dissatisfied with the Service Dealer's analysis or with the assistance provided, contact us at:

LCB Customer Care Department
Toro Warranty Company
8111 Lyndale Avenue South
Bloomington, MN 55420-1196
Toll Free: 888-865-5676 (U.S. customers)
Toll Free: 888-865-5691 (Canada customers)

Owner Responsibilities

You must maintain your Toro Product by following the maintenance procedures described in the *Operator's Manual*. Such routine maintenance, whether performed by a dealer or by you, is at your expense. Parts scheduled for replacement as required maintenance ("Maintenance Parts"), are warranted for the period of time up to the scheduled replacement time for that part. Failure to perform required maintenance and adjustments can be grounds for disallowing a warranty claim.

Items and Conditions Not Covered

Not all product failures or malfunctions that occur during the warranty period are defects in materials or workmanship. This express warranty does not cover the following:

- Product failures which result from the use of non-Toro replacement parts, or from installation and use of add-on, modified, or unapproved accessories
- Product failures which result from failure to perform required maintenance and/or adjustments
- Product failures which result from operating the Product in an abusive, negligent or reckless manner
- Parts subject to consumption through use unless found to be defective. Examples of parts which are consumed, or used up, during normal Product operation include, but are not limited to, teeth, tines, blades, spark plugs, tires, tracks, filters, chains, etc.
- Failures caused by outside influence. Items considered to be outside influence include, but are not limited to, weather, storage practices, contamination, use of unapproved coolants, lubricants, additives, or chemicals, etc.
- Normal "wear and tear" items. Normal "wear and tear" includes, but is not limited to, worn painted surfaces, scratched decals or windows, etc.
- Any component covered by a separate manufacturer's warranty
- Pickup and delivery charges

General Conditions

Repair by an Authorized Toro Compact Utility Equipment (CUE) Service Dealer is your sole remedy under this warranty.

Neither The Toro® Company nor Toro Warranty Company is liable for indirect, incidental or consequential damages in connection with the use of the Toro Products covered by this warranty, including any cost or expense of providing substitute equipment or service during reasonable periods of malfunction or non-use pending completion of repairs under this warranty. All implied warranties of merchantability and fitness for use are limited to the duration of this express warranty. Some states do not allow exclusions of incidental or consequential damages, or limitations on how long an implied warranty lasts, so the above exclusions and limitations may not apply to you.

This warranty gives you specific legal rights, and you may also have other rights which vary from state to state.

Except for the engine warranty coverage and the Emissions warranty referenced below, if applicable, there is no other express warranty. The Emissions Control System on your Product may be covered by a separate warranty meeting requirements established by the U.S. Environmental Protection Agency (EPA) or the California Air Resources Board (CARB). The hour limitations set forth above do not apply to the Emissions Control System Warranty. Refer to the California Emission Control Warranty Statement supplied with your Product or contained in the engine manufacturer's documentation for details.

Countries Other than the United States or Canada

Customers who have purchased Toro products exported from the United States or Canada should contact their Toro Distributor (Dealer) to obtain guarantee policies for your country, province, or state. If for any reason you are dissatisfied with your Distributor's service or have difficulty obtaining guarantee information, contact the Toro importer. If all other remedies fail, you may contact us at Toro Warranty Company.