

982

Operating & Maintenance Instructions



37" Mower Rear Easy Twin Grass Bagger - 11 Cu. Ft.

Garden Tractor
Easy Twin
Grass Bagger



Wheel Horse®
Tractors & Riding Mowers

VEHICLE IDENTIFICATION (VIN) NUMBER

A Vehicle Identification Number identifies your Toro Wheel Horse bagging attachment. Always refer to this number when consulting with your dealer or factory about service, replacement parts, or questions you may have. Replace VIN plate if it becomes lost during operation or maintenance. For your reference, record below the number from VIN plate on your attachment.

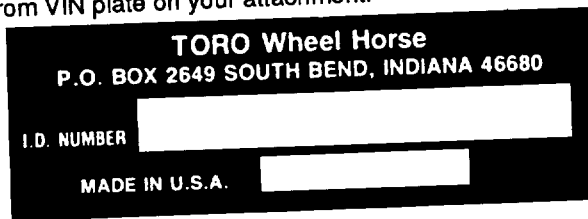

DESCRIPTION

The grass bagger covered in this manual is designed to fit Toro Wheel Horse garden tractors with 37 inch side discharge mowers.

ASSEMBLY

Install Discharge Elbow (Figures 1 & 2)



Sharp edges of mower blade can cut you during blade maintenance or adjustment. Use suitable covering over cutting edges of blade to prevent bodily harm.

Install supplied high lift blade on right (discharge side) spindle, in place of blade supplied with mower (Fig. 1). Lift tabs point toward mower deck.

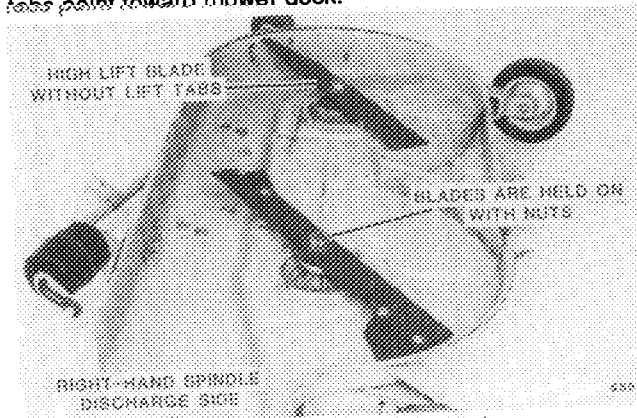

FIG. 1. Install High Lift Blades

Remove discharge chute and install supplied discharge elbow over mower discharge opening. Locate small hairpin cotter and place through end loop of elbow lanyard. Locate and install "U" shaped elbow latch through middle loop of elbow lanyard.

Secure discharge elbow to mower by sliding elbow latch down over front of discharge elbow and anti-scalp roller bracket (Fig. 2). Secure in place with hairpin cotter.

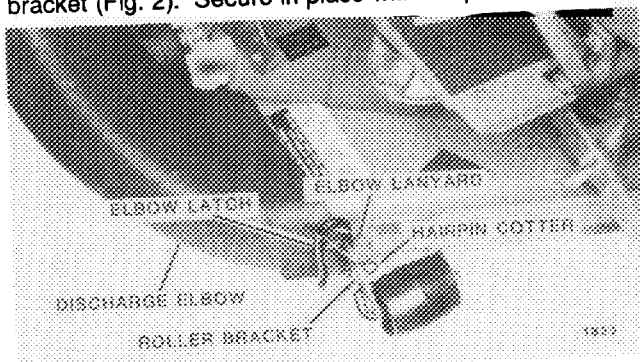

FIG. 2. Install Discharge Elbow

Install Bagger (Figure 3 thru 11)

Locate left hand support bracket and two supplied 5/16-18 x 7/8 bolts and lock nuts (Fig. 3). Remove one fender support nut and bolt, and install support bracket using hardware supplied (Fig. 3).

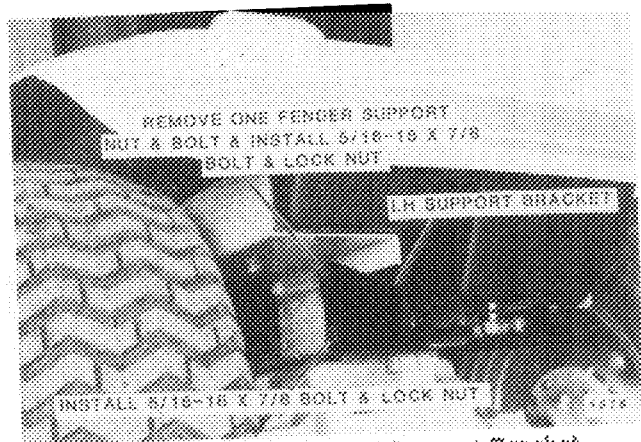

FIG. 3. Install Left Hand Support Bracket

Locate right hand support bracket and two supplied 5/16-18 x 7/8 bolts and lock nuts (Fig. 4). Remove two fender support nuts and bolts, and install support bracket using hardware supplied (Fig. 4).



FIG. 4. Install Right Hand Support Bracket

Locate quick attach bracket (Fig. 5) and mount on draw bar hitch and support brackets. Secure with supplied hairpin cotters.

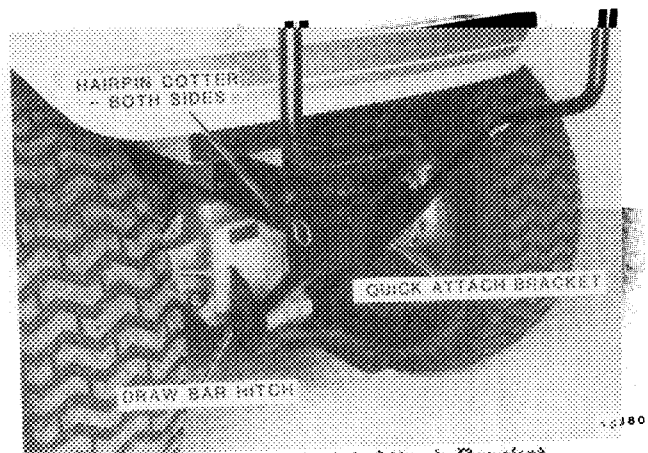

FIG. 5. Install Quick Attach Bracket

Rest bagger top upside down on clean surface, protecting exterior of top. Locate full bag feeler and route through chute seal and bagger top slot from inside out (Fig. 6). Install two supplied clips on full bag feeler as shown (Fig 6.).

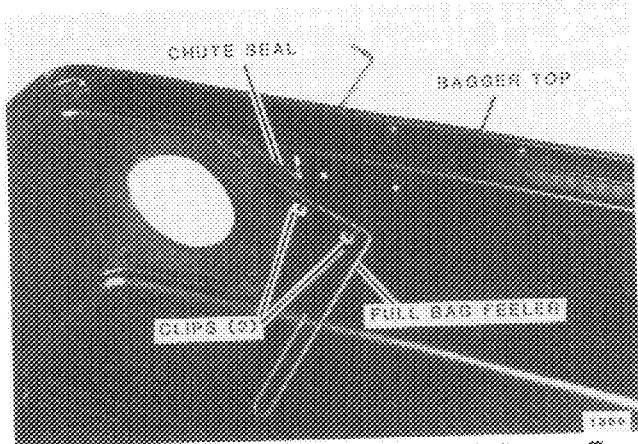

FIG. 6. Install Full Bag Feeler Through Bagger Top

Install two supplied 1/4-20 x 5/8 pan head screws through bagger top and full bag feeler clips from outside in. Secure on inside with 1/4-20 lock nuts (Fig. 7). Locate 1/4-20 jam nut and feeler handle. Thread jam nut all the way onto full bag feeler end. Thread handle on feeler end so that letters face forward and tighten jam nut against handle (Fig. 7).

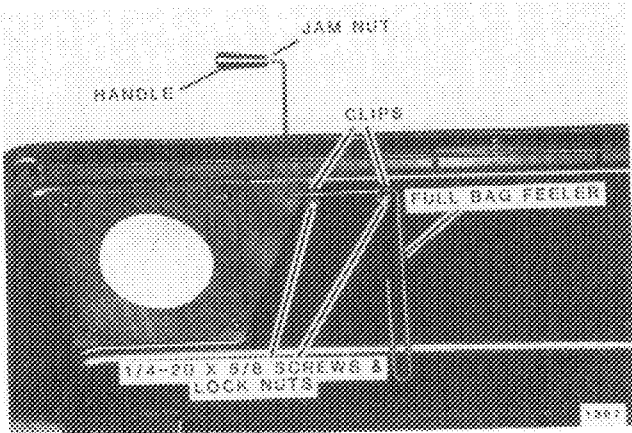

FIG. 7. Secure Full Bag Feeler and Install Handle
Locate bagger top frame/hinge assembly.

Mount frame/hinge assembly to bagger top using bolts already attached to frame/hinge assembly and supplied lock nuts (Fig.8). Tighten securely.

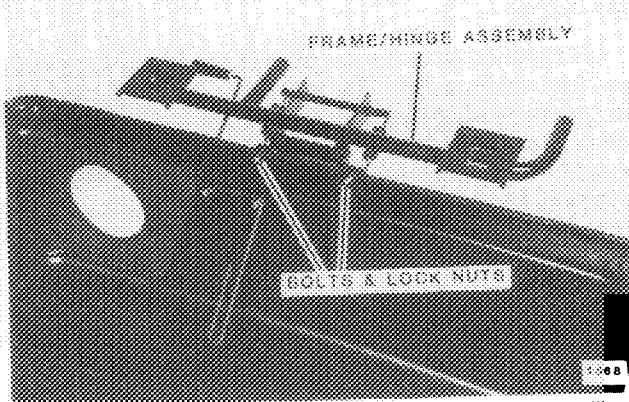

FIG. 8. Install Frame/Hinge Assembly to Bagger Top

Raise tractor seat. Carefully lift bagger top assembly and slip top onto quick attach bracket (Fig. 9).

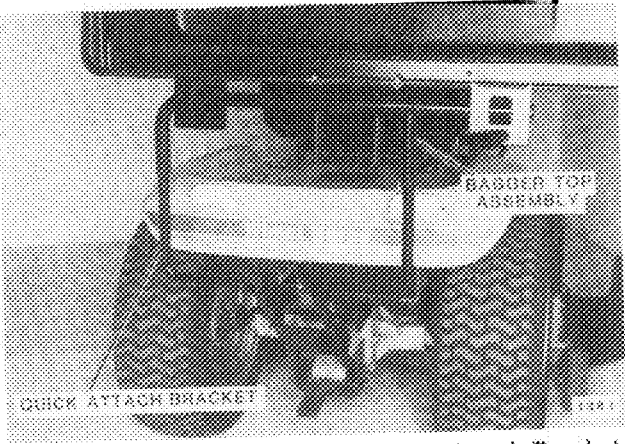

FIG.9. Install Bagger Top on Quick Attach Bracket

Locate two supplied bags and install on frame hooks (Fig. 10).

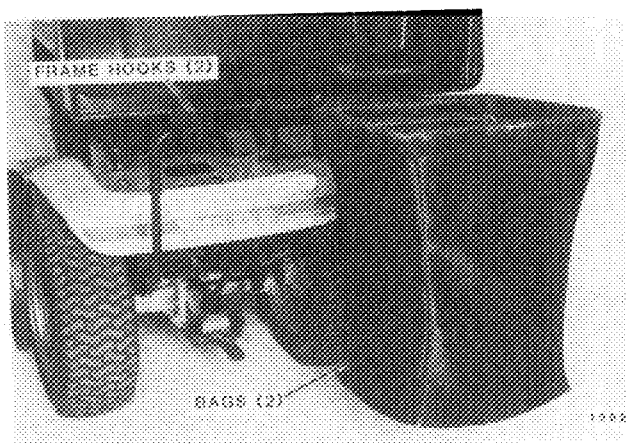

FIG.10. Install Bags

Lower bagger top. Note that bagger top latches onto bags (Fig. 11).



FIG. 11. Bagger Top Latches

Lower tractor seat. Insert discharge tube into opening in bagger top, then slip tube over discharge elbow until tube locks in position (Fig. 12).

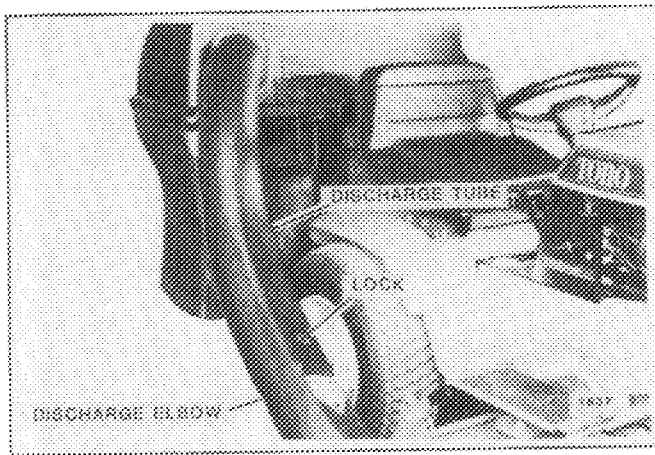

FIG. 12. Install Discharge Tube

REMOVAL

After initial installation, rear grass bagger is removed by the following methods:

1. Remove discharge tube by compressing tube lock with both thumbs (Fig. 13). Remove discharge elbow. Discharge tube and discharge elbow may be left connected and removed as a unit.

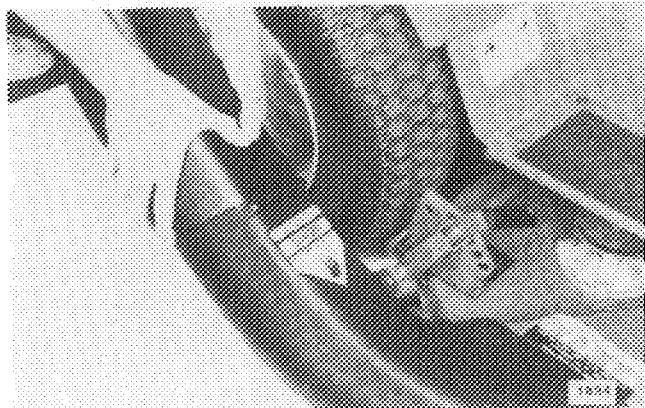

FIG. 13. Discharge Tube Removal

2. Raise tractor seat. Release both bagger top latches and raise bagger top. Remove both bags.

CAUTION
DO NOT remove bagger top from support rods when top is closed. Spring loaded frame assembly may unexpectedly trip. Open top and remove bags before removing top from quick attach assembly.

3. Lift bagger top off quick attach bracket.
4. Remove bagger quick attach bracket and both support brackets. Support brackets may be left installed if they do not interfere with other attachments. Reinstall removed hardware.
5. Remove high lift blade and install "standard" mower blade and standard side discharge chute.

CAUTION
Sharp edges of mower blade can cut you during blade maintenance or adjustment. Use suitable covering over cutting edges of blade to prevent bodily harm.

CAUTION

Never operate mower unless discharge chute is in place or complete rear grass bagger is installed. High lift blade is for use ONLY with this bagging attachment. Always install "standard" mower blade when mowing without bagger attachment installed.

OPERATION

CAUTION

Become familiar with all operating instructions and safety suggestions contained in applicable Operator's Manuals before attempting to operate this equipment. Never do any maintenance or repairs while engine is running. Never remove discharge tube, top or remove grass bag while engine is running.

With a few exceptions, operation of tractor with rear grass bagger is similar to operation without it. Keep in mind that tractor is made longer and wider when this attachment is installed, so be sure to avoid sharp turns in confined places. Also, do not trim with right side of mower. Trimming with right side of mower can result in damage to the discharge elbow.

Bagger attachment is designed to operate efficiently at normal mowing speed. Due to extra amount of power required to drive mower, it may be necessary to reduce ground speed of tractor to keep engine running smoothly, at maximum governed RPM. When mowing uphill, it is recommended that tractor's ground speed be reduced by at least one gear. This will help to avoid a large power drop and loss of "suction". When practical, set up a mowing pattern that will permit as much downhill as possible.

CAUTION

Avoid stopping when mowing uphill. If it becomes necessary to stop when moving uphill, place tractor back into motion with extreme care.

Suction action generated by mower is capable of picking up grass clippings, leaves, small twigs and other light debris from lawn and deposit them in grass bags. Remove larger twigs, branches, tree limbs, stones and other solid debris from lawn before mowing to avoid damage to mower and grass bagger.

Lift Full Bag Tester handle periodically to check if grass bags are becoming full. The left bag will normally fill first. Then, as the right bag fills, resistance will be felt when Full Bag Tester handle is lifted, indicating bags are full. During operation, a small amount of grass clippings will normally be blown out front of mower. When this flow increases, this is also an indication that grass bags are full.

If suction action, or pick-up should stop during use, disengage mower and shut off engine. Check for full grass bags or a clogged discharge elbow, mower or discharge tube. Always empty bags when filled and after each use.

⚠ CAUTION ⚠

Grass bags are not storage containers. Never leave fresh grass clippings or other organic matter in bags for any length of time. Under the right conditions spontaneous combustion, a fire generating process which occurs without an external source of ignition, can occur with this type of material.

Grass bags can weigh up to 90 lbs. (41 kg) when full. Use care when removing or handling a filled grass bag.

Emptying the Bags

Raise seat of tractor and release both bagger top latches. Raise bagger top and gently compress debris into bags. With both hands, lift up on one of the bags to release from frame hook. Dispose of debris and reinstall. Repeat for other bag.

Plastic liners may be inserted in grass bags to ease disposal of grass clippings. If plastic liner is used, remove bag and tie top of liner. Pull liner out of bag or turn bag upside down while holding web handle on bottom of bag to allow the filled liner to slide out.

This bagging attachment may be used with or without plastic liners.

MAINTENANCE AND STORAGE

Normal maintenance of rear grass bagger attachment is minimal. After use, remove and wash top and discharge tube with garden hose. Use a mild automotive detergent to remove stubborn dirt. After washing allow parts to thoroughly dry. Check elbow and underside of mower after use and clean as necessary. Matted grass in these areas can seriously effect cutting performance.

Keeping grass bags dry will help prevent deterioration of bag material and add to the useful life of bags. Therefore, store bags in a manner that will insure complete drying after use. Washing bags is not recommended.

After first 10 hours of operation, inspect that all parts of bagger and all fasteners are in good condition. Pay particular attention to condition of elbow, tube and top - replace these parts if cracked or broken. Also inspect high lift blade after every 10 operating hours. Refer to Fig. 14, and inspect for cracked lift tabs on blade, or severely worn hardware. Wear will be more significant in dry areas having sandy soils.

⚠ CAUTION ⚠

Inspect bagger at specified intervals and replace worn or deteriorated parts using new Toro Wheel Horse replacement parts.

Inspect blades at specified interval, and whenever a blade strikes a foreign object.

1. Always replace worn or cracked lift tabs and worn hardware with new parts, **DO NOT** reuse or attempt repair.
2. Install new lift tab as shown in figure 14; use **ONLY** hardware supplied with replacement lift tab. Tighten hardware to specified torque value.
3. Always balance blade after replacing lift tab or sharpening blade. If blade is badly worn, install a new blade assembly.

Before storing attachment, clean it thoroughly and allow it to dry. Store bagger in a clean, dry place, out of direct sunlight. This will protect plastic parts and extend life of bagger. Use a weatherproof cover if stored outside.

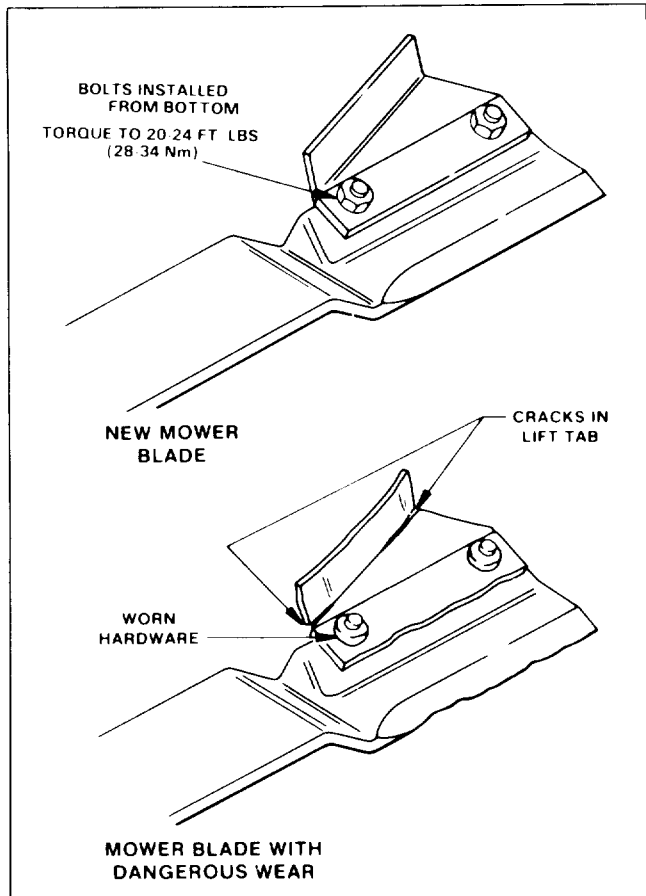

FIG. 14. Inspect High Lift Blade

A separate parts manual for your Toro Wheel Horse product can be obtained by completing the attached form below. You will receive an invoice with manual.

**PUBLICATIONS
TORO WHEEL HORSE
P.O. Box 2649
South Bend, Indiana 46680**

PARTS MANUAL ORDER FORM

Enter number shown on your attachment:

TORO Wheel Horse
P.O. BOX 2649 SOUTH BEND, INDIANA 46680

I.D. NUMBER

MADE IN U.S.A.

MAIL LABEL -- PLEASE PRINT CLEARLY

TO:

Name

Address

City State Zip

Product information and specifications are shown herein as of the time of printing. Toro Wheel Horse reserves the right to change product specifications, designs and standard equipment without notice and without incurring obligation.

Right at home.



Wheel Horse®

Tractors & Riding Mowers