

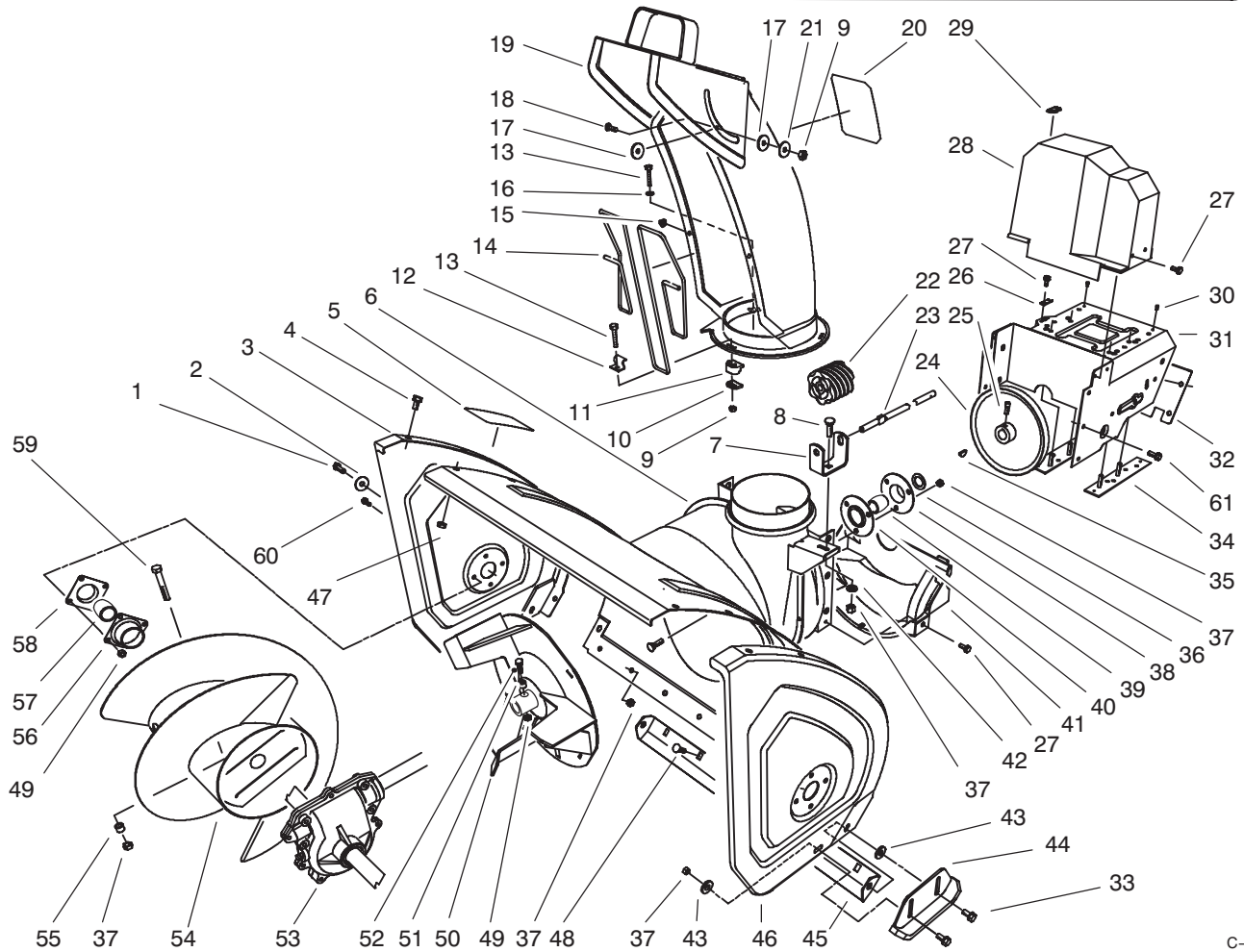

MODEL NO. 38540-7900001 & UP
 MODEL NO. 38543-7900001 & UP

PARTS
 CATALOG

**824 POWER SHIFT[®]
 SNOWTHROWER**



C-0045

HOUSING & CHUTE ASSEMBLY

Ref. No.	Part No.	Description	No. Used	Ref. No.	Part No.	Description	No. Used
1	323-6	Screw - Hex. Hd.	2	16	3256-14	Washer - Flat	1
2	3-0750	Washer - Retaining	2	17	63-2900	Washer - Plastic	2
3	66-7821	Plate - Side R.H.	1	18	32122-32	Screw	1
4	3234-28	Screw - Hex. Flange Hd.	12	19	62-0840	Chute Assembly	1
5	53-7670	Decal - Danger Auger	1	20	94-8079	Decal - Danger Chute	1
*	94-2568	Decal - Danger Auger Model No. 38540	1	*	94-2559	Decal - Danger Chute	1
6	62-0720	Housing - 24"	1	21	3256-61	Washer - Flat	1
7	63-2180	Bracket - Gear	1	22	62-0820	Gear - Worm	1
8	3230-2	Bolt - Carriage	1	23	62-1720	Rod - Chute Gear	1
9	3296-2	Nut - Lock	4	24	62-1300	Pulley - Impeller	1
10	63-2670	Plate - Chute Retainer	3	25	3242-4	Screw - Set Sq. Hd.	2
11	62-1430	Retainer - Chute	3	26	63-2300	Retainer - Cable	1
12	63-3130	Clip - Chute Guard	1	27	32144-4	Screw - Hex. Flange Hd.	5
13	3274-13	Screw - Machine	3	28	63-2080	Cover - Belt (Upper)	1
14	63-3020	Guard - Chute	1	29	63-3290	Cover - Cable	1
15	3290-326	Nut - Push	2	30	3269-23	Rivet	4

*Not Illustrated

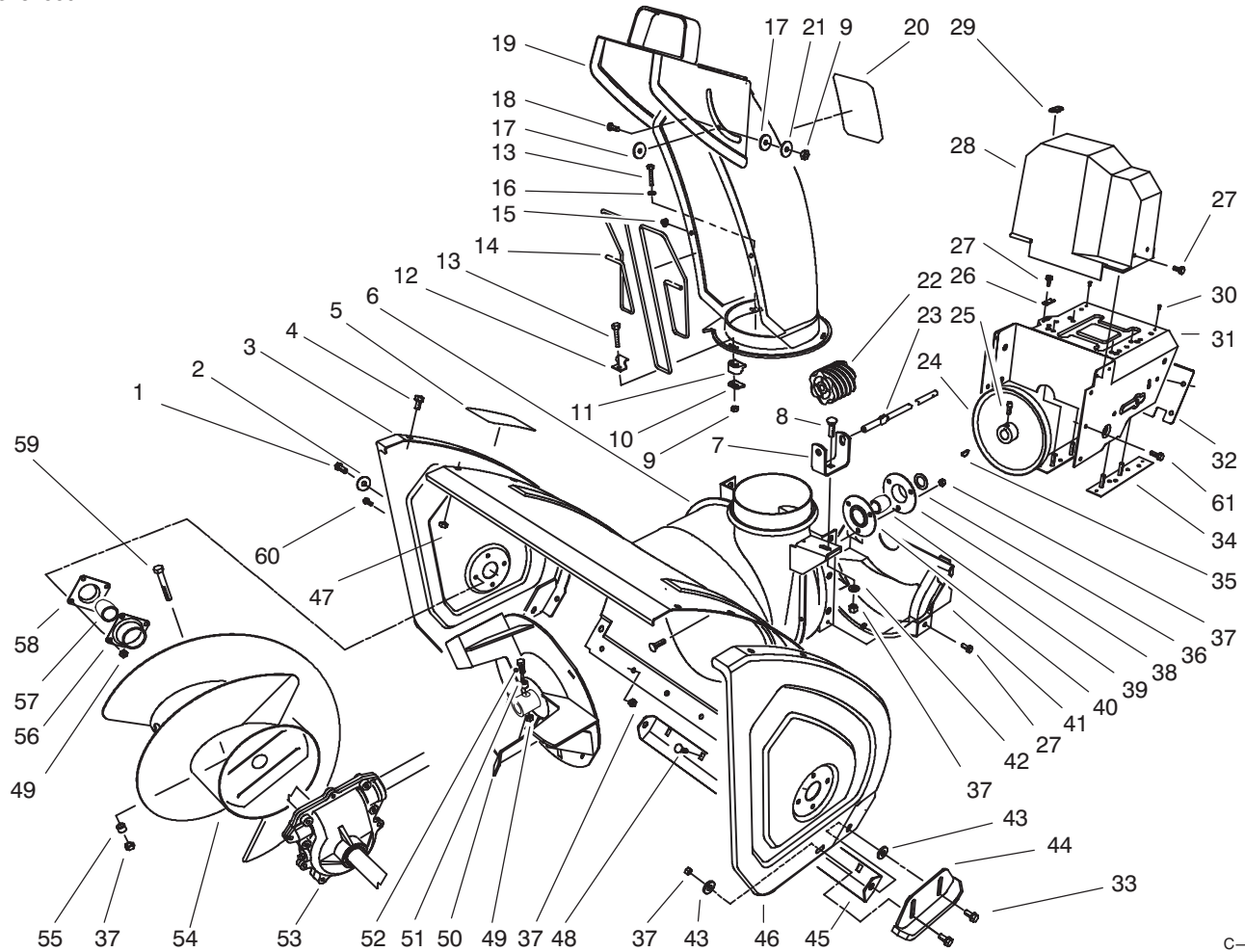

C-0045

HOUSING & CHUTE ASSEMBLY (Continued)

Ref. No.	Part No.	Description	No. Used
31	66-6980	Frame -- Engine	1
32	62-1440	Cover -- Engine Frame	1
33	3234-5	Screw -- Hex.. Washer Hd.	4
34	68-4110	Plate -- Engine Stud L.H.	1
*	68-4100	Plate -- Engine Stud R.H.	1
35	3257-23	Key -- Woodruff	1
36	252-80	Washer -- Thrust	1
37	3296-29	Nut -- Lock	14
38	26-6110	Flange -- Bearing (Front)	1
39	63-3450	Bearing -- Impeller	1
40	26-6120	Flange -- Bearing (Rear)	1
41	68-8410	Cover -- Belt (Lower)	1
42	3256-23	Washer -- Flat	1
43	52-2861	Washer	4
44	74-1440	Skid Assembly	2
45	66-7762	Blade -- Scraper	1
46	66-7831	Plate -- Side L.H.	1
47	3296-47	Nut -- Lock	20

Ref. No.	Part No.	Description	No. Used
48	3230-23	Screw -- Carriage	9
49	3296-42	Nut -- Lock	10
50	66-7910	Impeller	1
51	66-8010	Spacer	2
52	321-44	Screw -- Hex. Hd.	2
53	74-1560	Auger Gearbox Assembly	1
54	68-7450	Auger -- R.H.	1
*	68-7460	Auger -- L.H.	1
55	25-5090	Spacer -- Auger Hub	2
56	20-0990	Flange -- Bearing (Inner)	2
57	20-0980	Bearing -- Auger	2
58	20-1000	Flange -- Bearing (Outer)	2
59	322-12	Bolt -- Auger	2
60	321-3	Screw -- Hex. Hd.	8
61	3234-7	Screw	6
*	12-8789	Impeller Bearing Assembly (Incl. Ref. #38-40)	1

*Not Illustrated

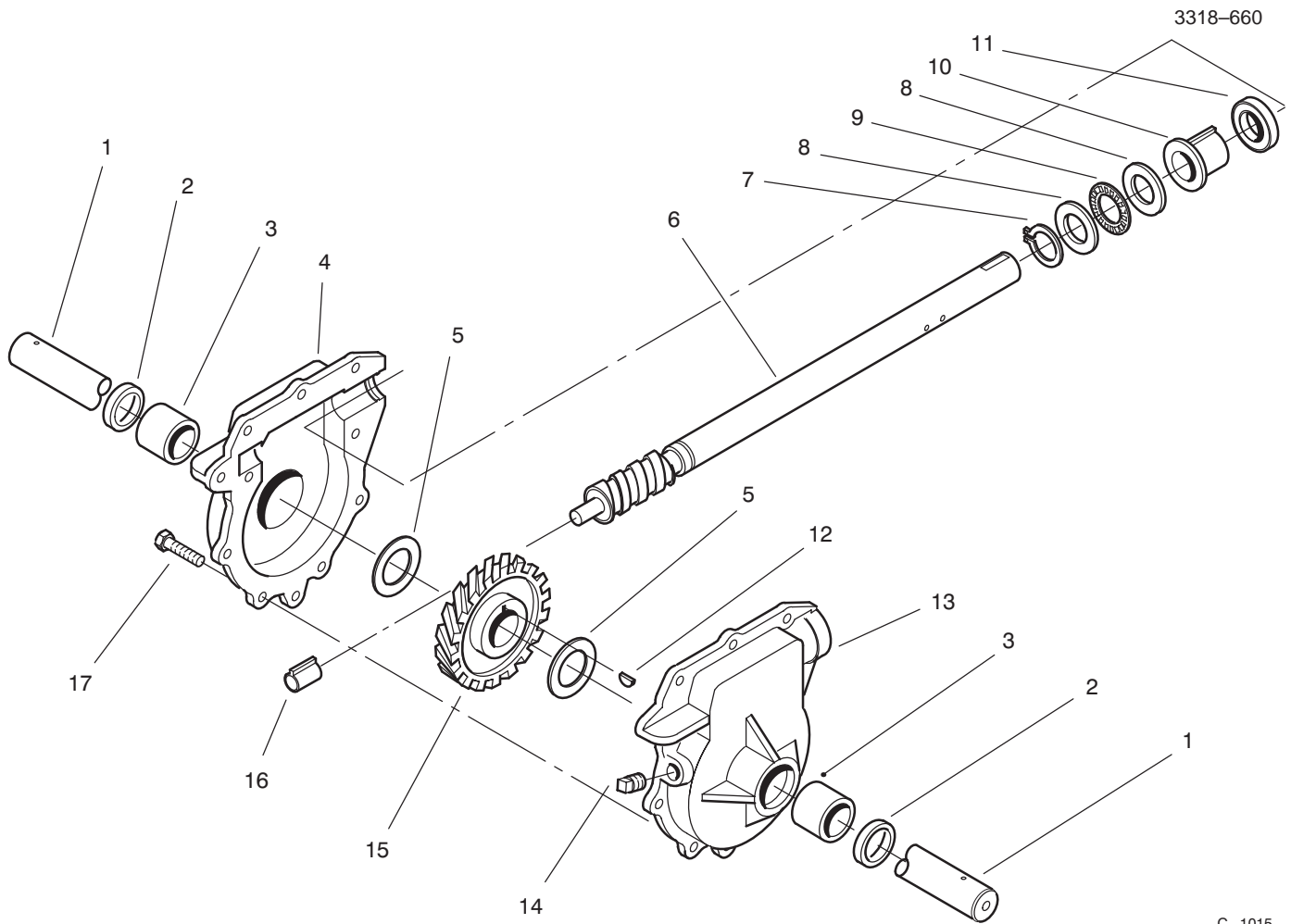

C-1015

24" AUGER GEARCASE ASSEMBLY NO. 74-1560

Ref. No.	Part No.	Description	No. Used
1	62-1530	Shaft - Auger 24"	1
2	7-0045	Seal - Oil	2
3	256-237	Bushing - Sleeve	2
4	74-1550	Gearcase Assembly - R.H. (Incl. Ref. # 2-3)	1
5	252-71	Bearing - Thrust	2
6	66-7811	Shaft - Impeller	1
7	32151-33	Ring - Snap	1
8	252-78	Washer - Thrust	2
9	252-76	Bearing - Thrust	1

Ref. No.	Part No.	Description	No. Used
10	37-6560	Bushing - Input	1
11	253-149	Seal - Input	1
12	3257-10	Key - Woodruff	1
13	74-1540	Gearcase Assembly - L.H. (Incl. Ref. # 2-3, & 17)	1
14	281-1	Plug - Pipe Sq. Hd.	1
15	62-0120	Gear - Helical	1
16	62-1150	Bushing - Worm	1
17	32144-110	Screw - Hex. Washer Hd.	9
*	505-129	Sealant - 100g Tube	1

*Not Illustrated

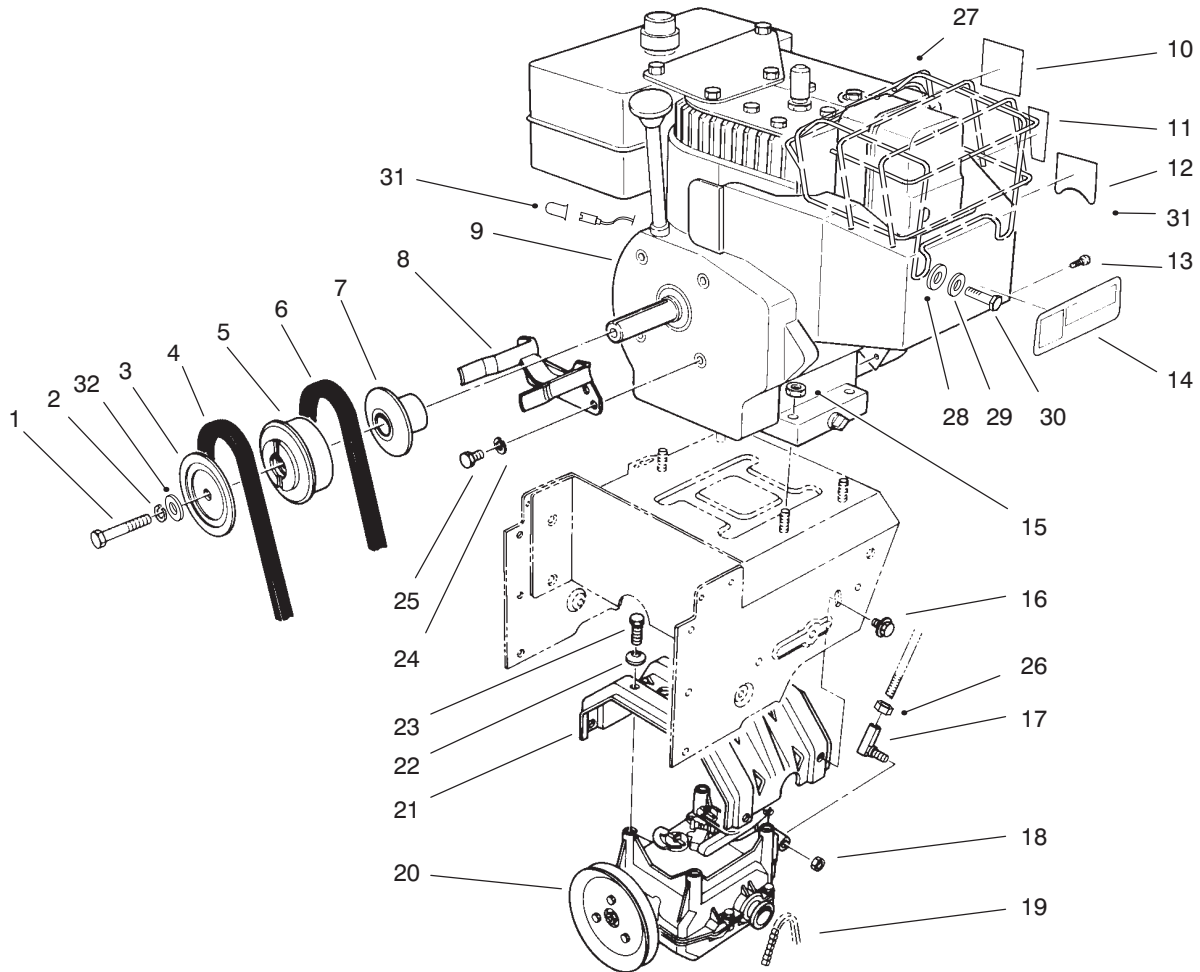

C-1727

ENGINE ASSEMBLY

Ref. No.	Part No.	Description	No. Used	Ref. No.	Part No.	Description	No. Used
1	3212-8	Screw - Hex. Hd.	1	18	3296-6	Nut - Lock	1
2	3253-6	Washer - Lock	1	19	63-2940	Chain - Drive	1
3	62-0940	Sheave Half - Impeller	1	20	66-8030	Transmission Assembly	1
4	63-2961	Belt - Impeller	1	21	63-2990	Frame - Transmission	1
5	62-0930	Hub - Sheave	1	22	3290-461	Washer - Belleville	4
6	63-2951	Belt - Traction	1	23	11-0590	Screw - Hex. Hd.	4
7	62-0920	Sheave Half - Traction	1	24	3253-4	Washer - Lock	2
8	68-7510	Guide - Belt	1	25	3210-1	Screw - Hex. Hd.	2
†9		Engine	1	26	3220-3	Nut - Jam	1
10	94-2572	Decal - Primer	1	†27	127-20	Guard - Muffler (Model 38543 Only)	1
11	63-2450	Decal - Throttle	1	†28	32-251-1	Washer - Flat (Model 38543 Only)	2
12	63-2410	Decal - Choke	1	†29	36-180	Washer - Lock (Model 38543 Only)	2
13	32144-4	Screw	1	†30	42-671	Screw - Self Tapping (Model 38543 Only)	2
14	93-1265	Decal - Hot Surface (Model 38543 Only)	1	31	94-2782	Cap - Wire	1
14	66-6840	Decal - Hot Surface (Model 38540 Only)	1	32	3256-41	Washer	1
15	32128-20	Nut - Lock	4				
16	3234-7	Screw - Hex. Flange Hd.	4				
17	78-2920	Joint - Ball	1				

*Not Illustrated

†Obtain from your local Tecumseh Dealer.

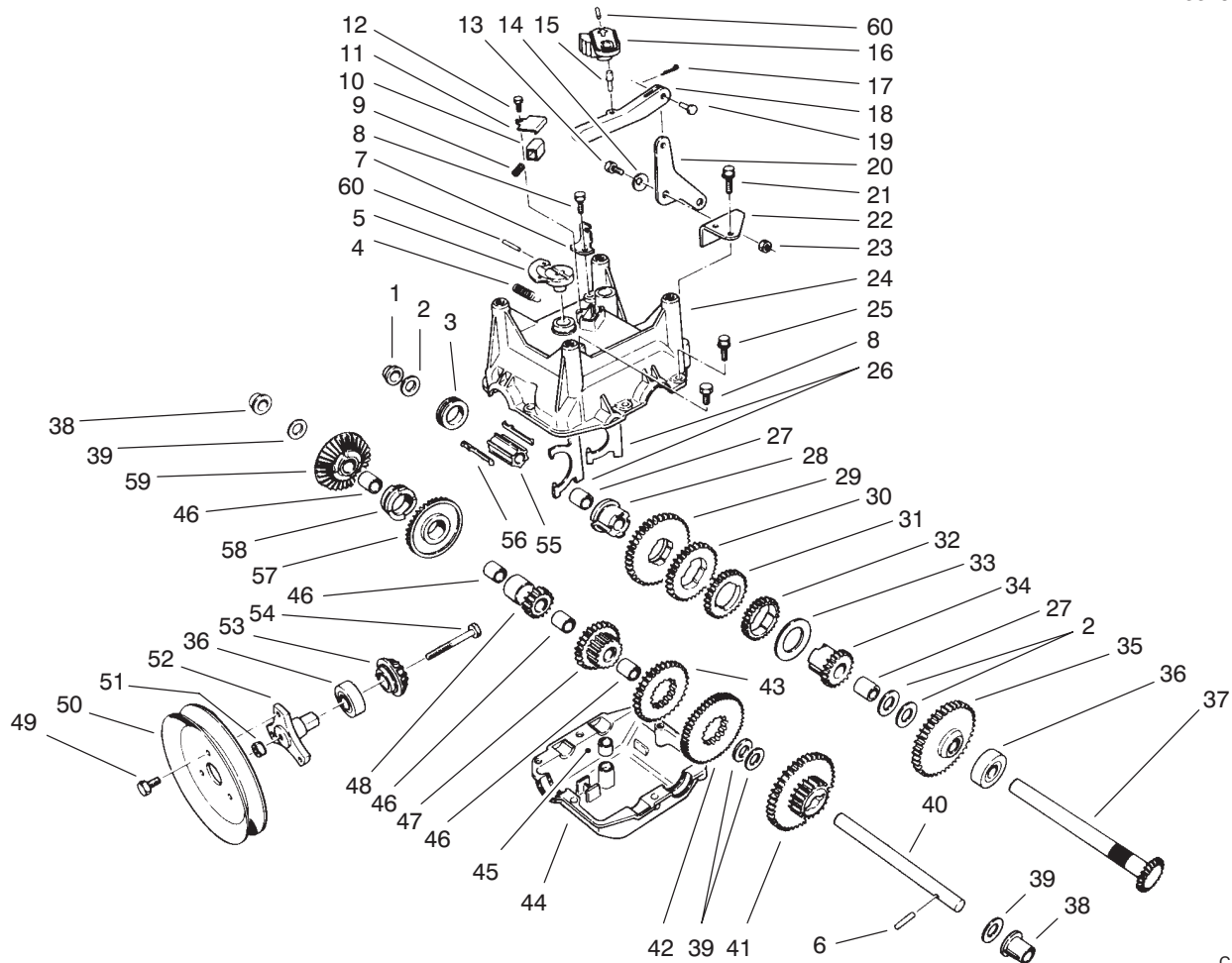

C-1736

TRANSMISSION ASSEMBLY NO. 66-8030

Ref. No.	Part No.	Description	No. Used	Ref. No.	Part No.	Description	No. Used
1	62-1180	Bushing - Output (Flange)	1	22	62-1190	Bracket - Bellcrank	1
2	252-59	Washer - Thrust	3	23	3296-42	Nut - Lock	1
3	62-0430	Collar - Shift (Speed)	1	24	62-0490	Gear Case - Upper	1
4	63-2920	Spring - Extension (F/R Return)	1	25	32144-86	Screw - Hex. Washer Hd.	6
5	62-0880	Lever - Direction Shift	1	26	62-1040	Yoke-Shift	2
6	32121-106	Pin - Coil	3	27	62-1350	Bushing - Output	2
7	62-1740	Bracket - Cable	1	28	62-0320	Sleeve	1
8	32144-4	Screw - Self Tapping	2	29	62-0240	Gear - 45T	1
9	63-2890	Spring - Compression (Detent)	1	30	62-0220	Gear - 34T	1
10	62-1020	Button - Detent	1	31	62-0200	Gear - 27T	1
11	62-1690	Cover - Detent	1	32	62-0250	Gear - 29T	1
12	32104-71	Screw - Pan Hd.	1	33	63-2280	Washer - Thrust	1
13	63-3410	Bolt - Shoulder	1	34	62-0340	Sleeve - Gear 19T	1
14	3290-477	Washer - Curved	1	35	62-0370	Gear - 41T	1
15	63-2190	Pin - Gearshift Link	1	36	38-7820	Bearing - Ball	2
16	62-0870	Lever - Gear Shift	1	37	62-1080	Shaft - Output	1
17	3272-1	Pin - Cotter	1	38	62-1170	Bushing - Flange	2
18	62-0860	Link - Gearshift	1	39	257-10	Washer - Thrust	4
19	283-3	Pin - Clevis	1	40	62-0330	Shaft - Intermediate	1
20	63-2600	Bellcrank	1	41	62-0360	Gear - Compound 19T/41T	1
21	32104-95	Screw - Hex. Washer Hd.	2	42	62-0260	Gear - 51T	1
				43	62-0210	Gear - 33T	1
				44	62-0480	Gear Case - Lower	1

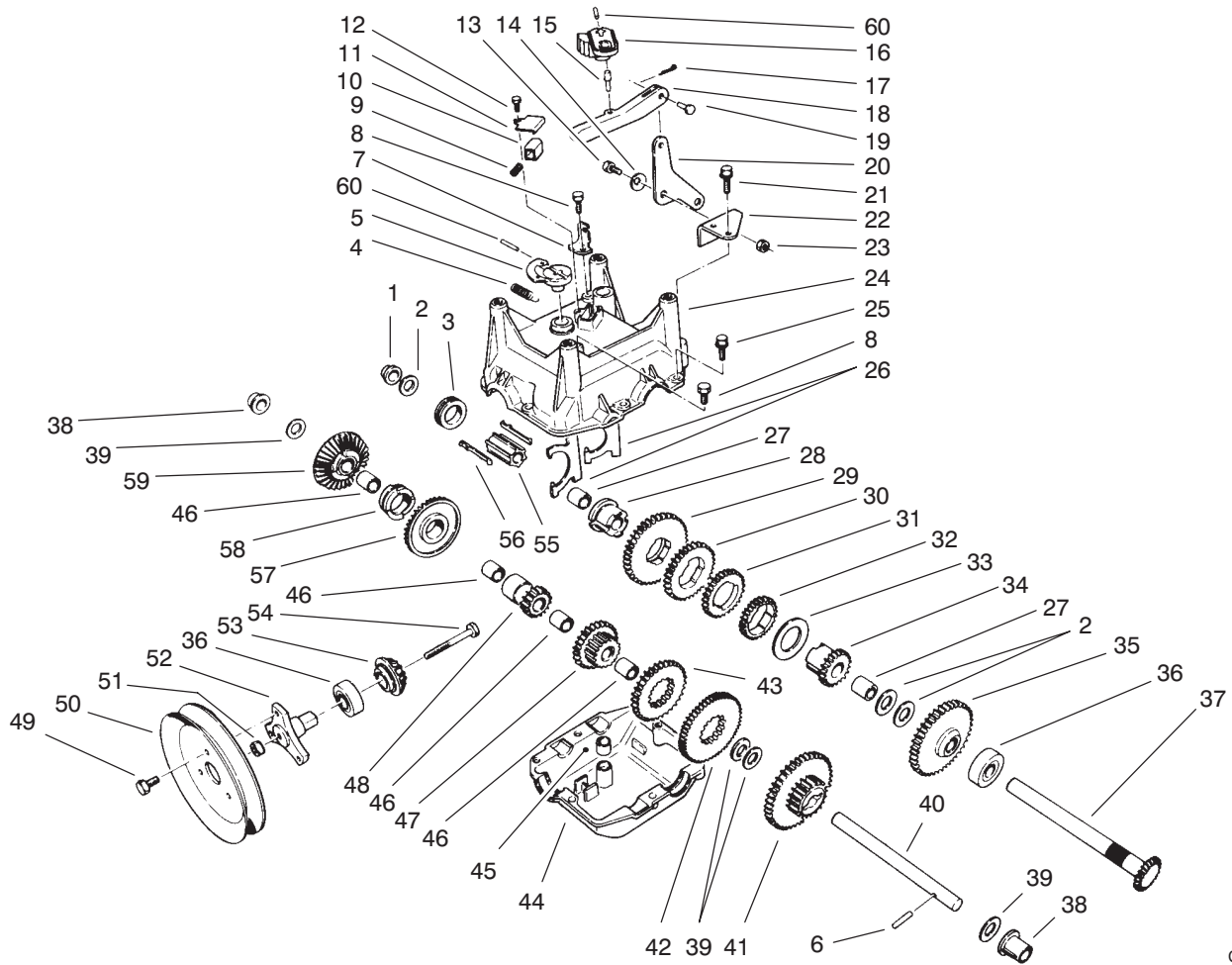

C-1736

TRANSMISSION ASSEMBLY NO. 66-8030 (Continued)

Ref. No.	Part No.	Description	No. Used
45	29-9570	Bushing - Yoke	1
46	62-1160	Bushing - Intermediate	4
47	68-4310	Gear - 26T	1
48	62-0500	Gear - 15T	1
49	12-3270	Screw	3
50	62-1310	Pulley - Traction	1
51	32128-32	Nut - Flange Lock	1
52	62-0380	Hub - Pulley	1
53	62-0350	Pinion - Bevel 19T	1

Ref. No.	Part No.	Description	No. Used
54	321-15	Screw - Hex. Hd.	1
55	68-4320	Sleeve - Shift	1
56	62-0310	Key - Shift	2
57	67-5870	Gear - Bevel 36T	1
58	67-5880	Collar - Shift	1
59	13-3559	Gear - Bevel Reverse 36T (Incl. Ref. #46)	1
60	32121-120	Roll - Pin	2
*	505-101	Grease - 14.5 oz. Cartridge	1

*Not Illustrated

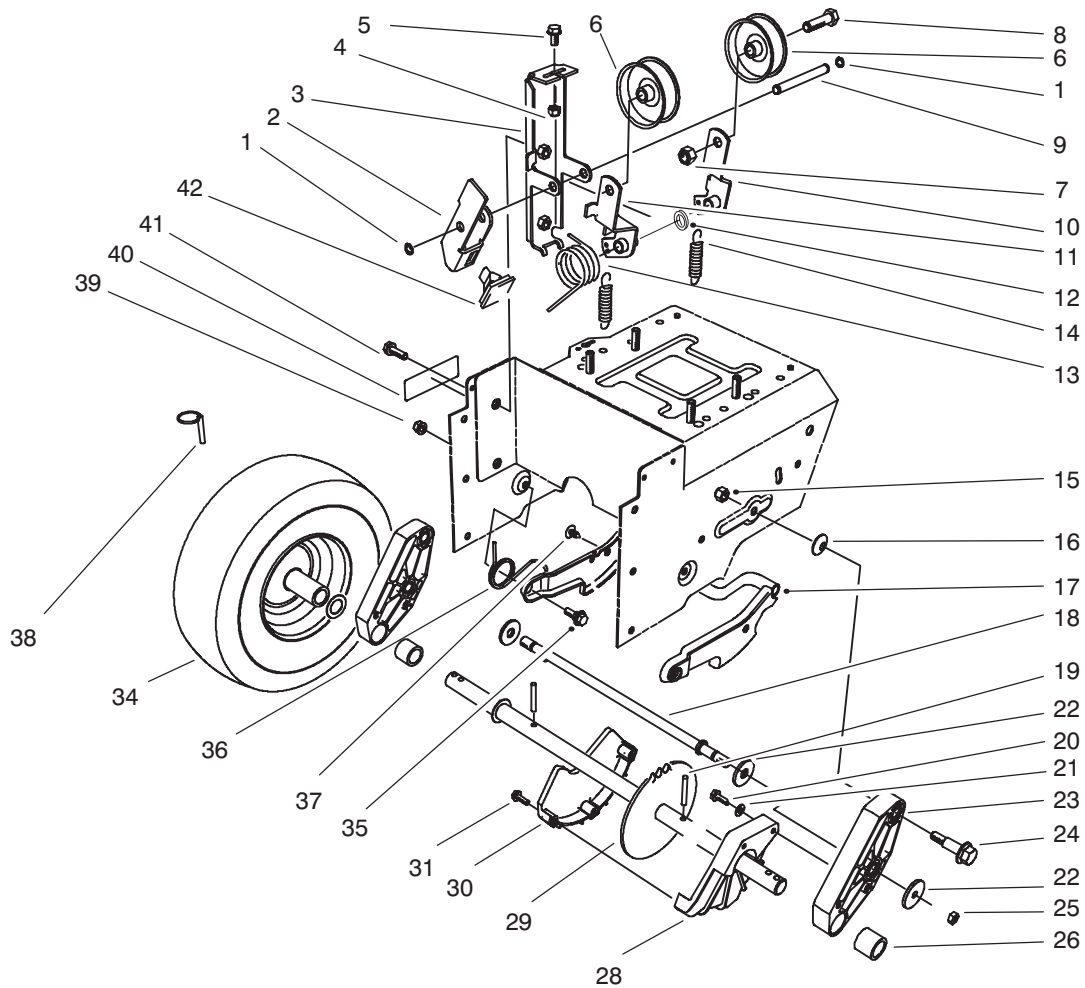

C-0053

TRACTION DRIVE ASSEMBLY

Ref. No.	Part No.	Description	No. Used	Ref. No.	Part No.	Description	No. Used
1	32120-46	Ring - Retaining	2	23	66-7740	Pivot Arm Assembly (Incl. Ref. # 26)	2
2	63-2810	Arm - Brake	1	24	62-1330	Bolt - Shoulder	2
3	63-2850	Bracket - Idler Arm	1	25	3296-23	Nut - Lock	2
4	3296-42	Nut - Lock	1	26	63-2250	Bushing - Axle	2
5	3234-13	Screw - Hex. Washer Hd.	1	27	252-80	Washer - Thrust	4
6	3-4244	Pulley - Idler	2	28	62-1010	Guard - Chain L.H.	1
7	3296-59	Nut - Lock	2	29	63-2111	Axle Assembly	1
8	323-7	Screw - Hex. Hd.	2	30	62-1000	Guard - Chain R.H.	1
9	62-0970	Pin - Idler	1	31	32104-121	Screw - Hex. Flange Hd.	3
10	93-8045	Arm - Traction Idler	1	34	67-9220	Tire & Wheel Assembly	2
11	93-8046	Arm - Impeller Idler	1	35	5-2490	Bolt - Shoulder	2
12	3256-38	Washer - Flat	1	36	63-2740	Spring - Torsion	1
13	63-2880	Spring - Torsion	1	37	3290-476	Fastener - Panel	1
14	63-2870	Spring - Extension	2	38	3290-243	Pin - Klik	2
15	3296-39	Nut - Lock	2	39	3296-47	Nut - Lock	2
16	3290-461	Washer - Belleville	2	40	66-6860	Decal - Warning (Model No. 38540 Only)	1
17	62-0470	Latch - Arm	1	*	94-2575	Decal - Warning (Model No. 38543 Only)	1
18	66-7720	Rod - Latch	1	41	3234-7	Screw - Hex. Flange Hd.	2
19	32121-9	Pin - Roll	2	42	66-8060	Pad - Brake	1
20	32144-4	Screw - Hex. Flange Hd.	2				
21	3256-1	Washer - Flat	2				
22	63-3340	Washer	4				

*Not Illustrated

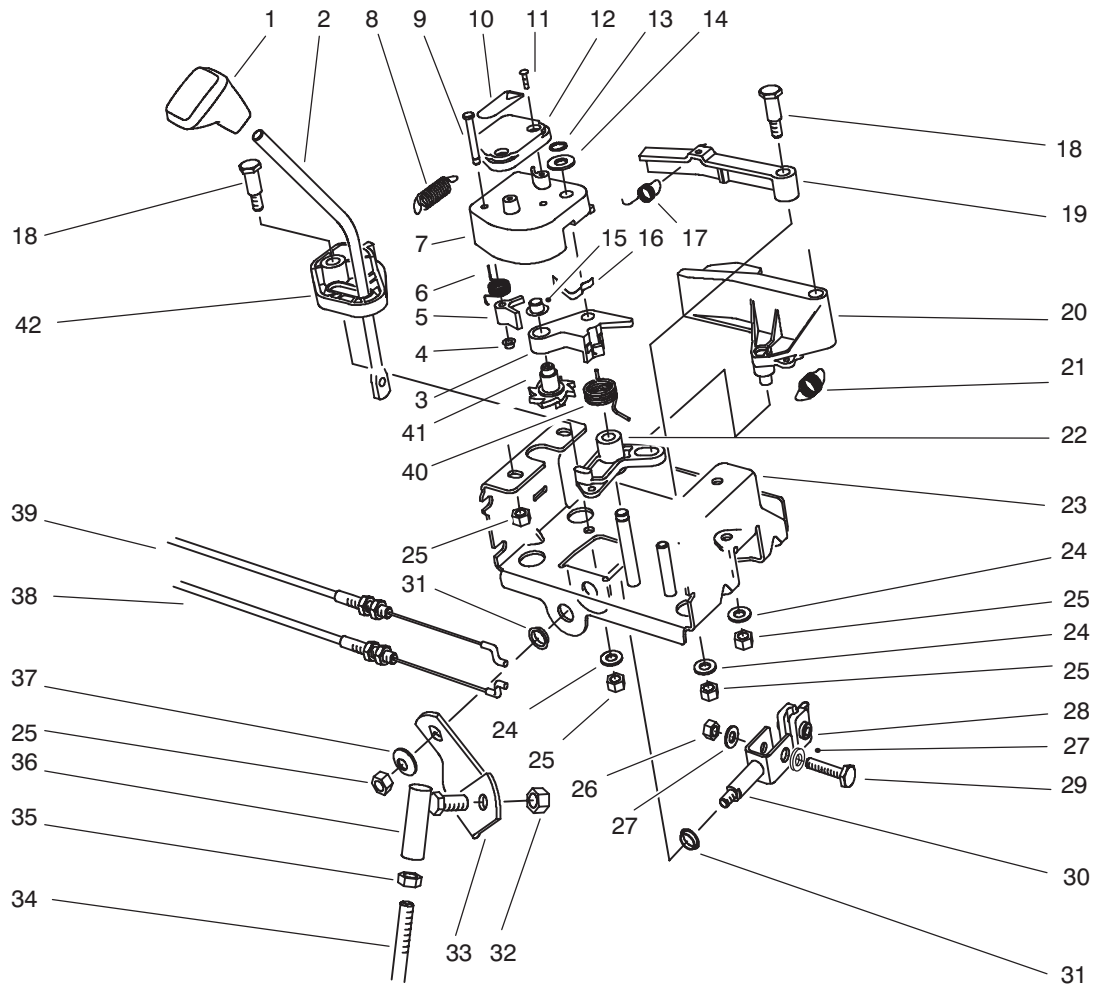

C-0054

TRACTION LINKAGE ASSEMBLY

Ref. No.	Part No.	Description	No. Used
1	62-1290	Knob - Shift	1
2	67-9240	Rod - Shift (Upper)	1
3	62-1110	Lever - Index Wheel	1
4	3290-422	Nut - Push	1
5	62-0180	Tang - Index	1
6	62-1650	Spring - Torsion	1
7	62-1100	Lever - Latch	1
8	63-2220	Spring - Extension	1
9	63-2610	Pin - Tang	1
10	63-2480	Decal - #2	1
11	94-6961	Screw - Pan Hd.	2
12	62-1140	Cover - Latch	1
13	32120-46	Ring - Retaining	1
14	257-9	Washer - Thrust	1
15	3290-320	Nut - Push	1
16	62-1710	Spring - Flat	1
17	63-2240	Spring - Extension	1
18	63-2650	Screw - Shoulder	2
19	62-1700	Lever - Lockout	1
20	62-1130	Lever - Reverse	1
21	63-2230	Spring - Extension	1

Ref. No.	Part No.	Description	No. Used
22	62-1120	Lever - Reverse	1
23	63-2150	Frame - Control	1
24	3256-23	Washer - Flat	3
25	3296-29	Nut - Lock	7
26	3296-42	Nut - Lock	1
27	3256-1	Washer - Flat	2
28	67-9250	Retainer - Shift Rod	1
29	321-9	Screw - Hex. Hd.	1
30	66-7730	Clevis	1
31	256-296	Bushing - Nyliner	2
32	3296-6	Nut - Lock	1
33	63-2630	Bracket - Shift	1
34	63-2830	Rod - Shift (Lower)	1
35	3220-3	Nut - Jam	1
36	78-2920	Joint - Ball	1
37	3290-456	Washer - Belleville	1
38	63-2210	Cable - Gearbox	1
39	63-2200	Cable - Latch	1
40	63-2270	Spring - Torsion	1
41	62-0170	Wheel - Index	1
42	62-1470	Base - Lockout	1

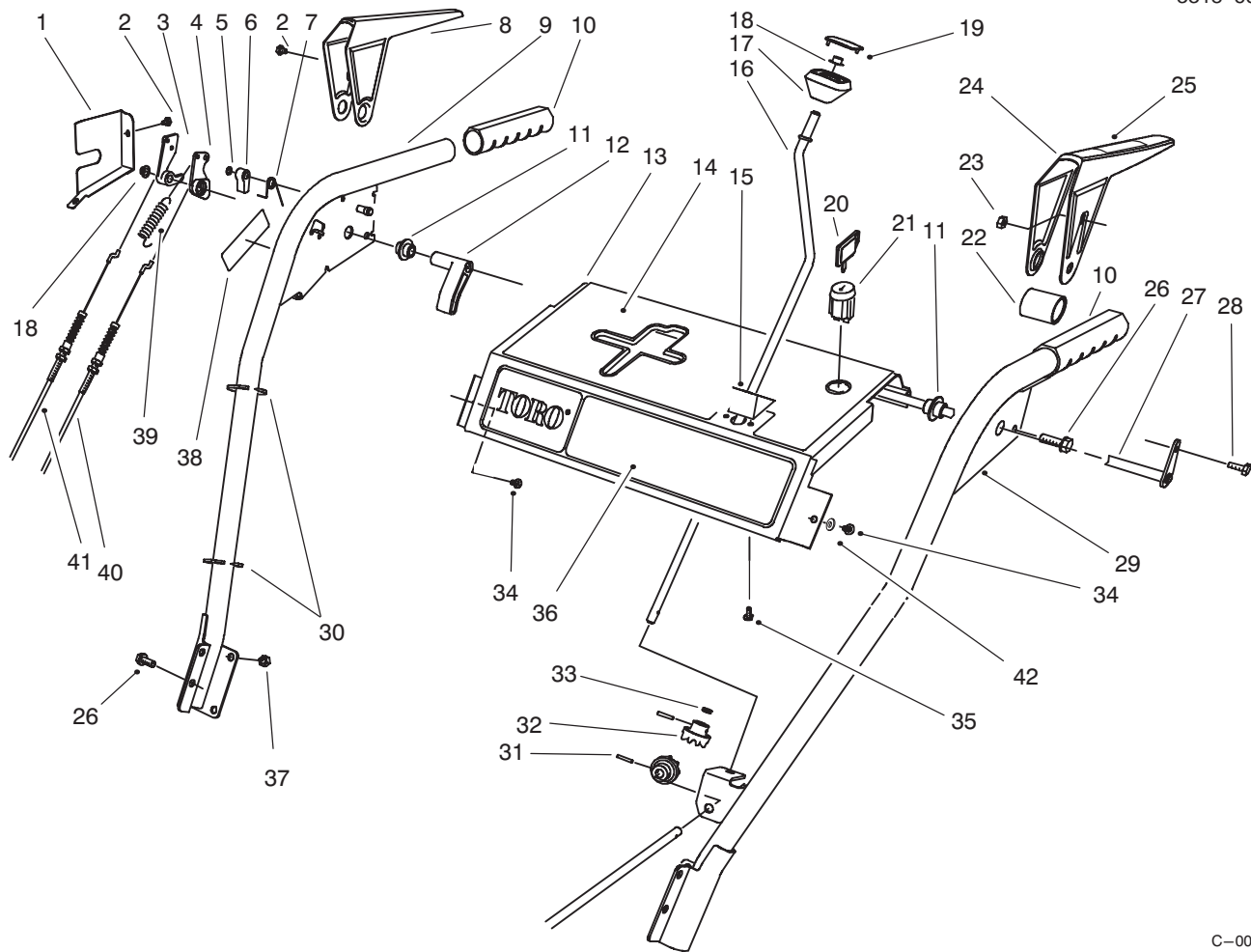

C-0055

HANDLE ASSEMBLY

Ref. No.	Part No.	Description	No. Used
1	63-2170	Cover - Lever Lock	1
2	2210-250	Screw	3
3	62-0300	Tang - Locking	1
4	62-0290	Cam - Release	1
5	32151-66	Ring - Retaining	1
6	62-0280	Latch - Lock	1
7	63-2910	Spring - Torsion	1
8	62-1050	Lever - Impeller	1
9	62-1380	Handle - R.H.	1
10	66-7850	Handlegrip	2
11	62-1070	Bushing - Lever	2
12	62-1640	Lever - Trip	1
13	66-8100	Panel - Control	1
14	66-6850	Decal - Panel Top (Model No. 38540 Only)	1
*	94-2578	Decal - Panel Top (Model No. 38543 Only)	1
15	62-1490	Plate - Guide	1
16	63-2160	Rod - Chute Crank	1
17	62-1320	Knob - Chute Control	1
18	3290-320	Nut - Push	2

Ref. No.	Part No.	Description	No. Used
19	62-1520	Cover - Knob	1
20	63-8360	Key - Switch	1
21	40-5940	Switch - On/Off	1
22	63-3380	Spacer - Traction Lever	1
23	3296-2	Nut - Lock	1
24	62-1060	Lever - Traction	1
25	63-3050	Decal - Lever (Model No. 38540 Only)	1
26	3234-7	Screw - Hex. Flange Hd.	6
27	63-2030	Rod - Cross	1
28	3290-359	Screw	1
29	66-8090	Handle - L.H.	1
30	3290-378	Tie - Cable	3
31	32121-50	Pin - Roll	2
32	62-1460	Gear - Universal	2
33	62-1230	Washer - Rubber	1
34	32104-76	Screw - Self Tapping	2
35	94-6961	Screw - Pan Hd.	2
36	63-2510	Decal - Panel Front	1
37	3296-47	Nut - Lock	4

*Not Illustrated

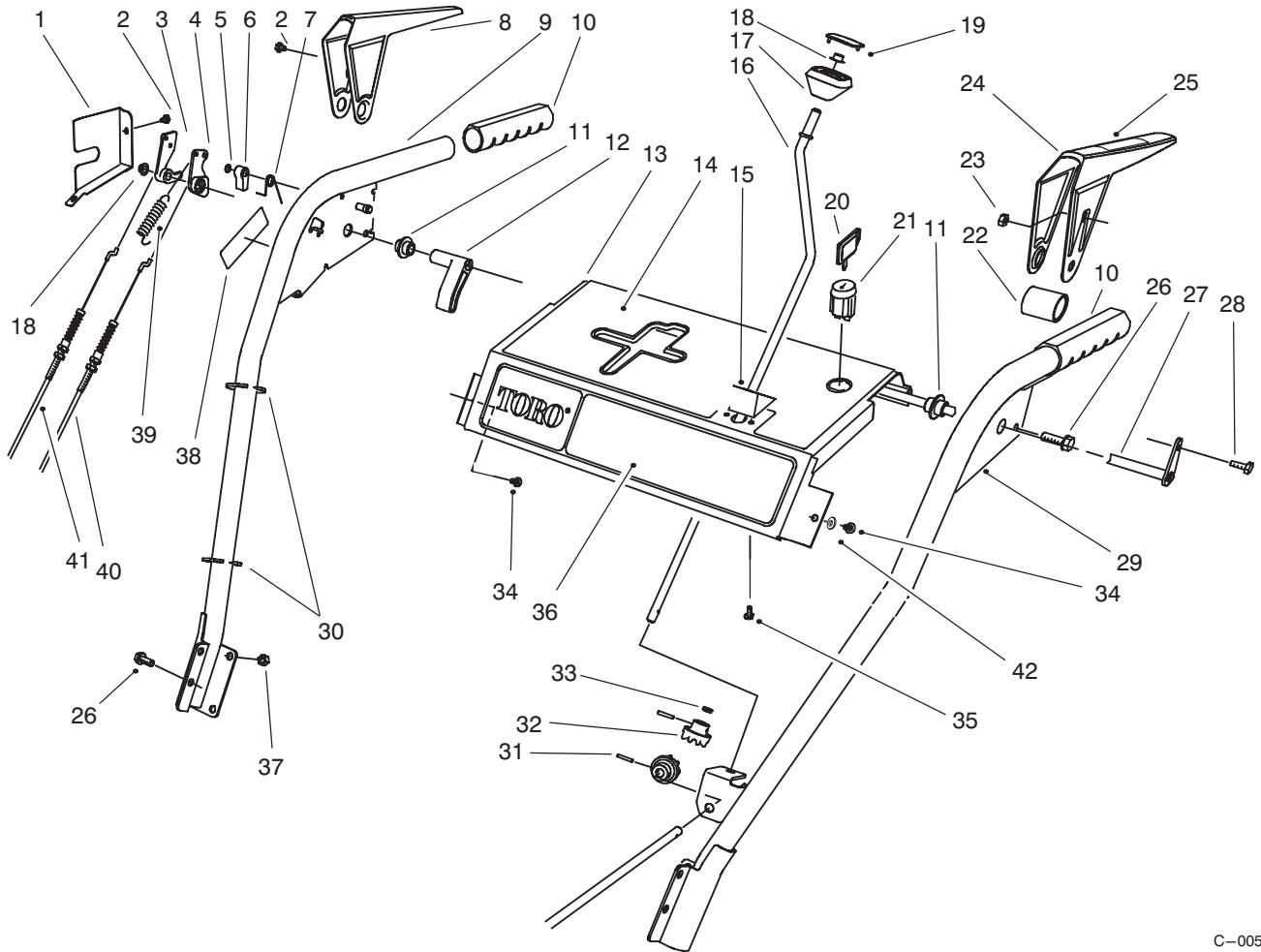

C-0055

HANDLE ASSEMBLY (Continued)

Ref. No.	Part No.	Description	No. Used	Ref. No.	Part No.	Description	No. Used
38	66-6860	Decal - Warning (Model No. 38540 Only)	1	42	3256-14	Washer - Flat	2
*	94-2575	Decal - Warning (Model No. 38543 Only)	1	*	63-3420	Harness - Wire	1
39	88-0810	Spring - Extension	1	*	17-4299	Loose Parts Kit (Model 38540 Only)	1
40	63-2710	Cable - Traction	1	*	17-4249	Loose Parts Kit (Model 38543 Only)	1
41	63-2700	Cable - Impeller	1				

*Not Illustrated

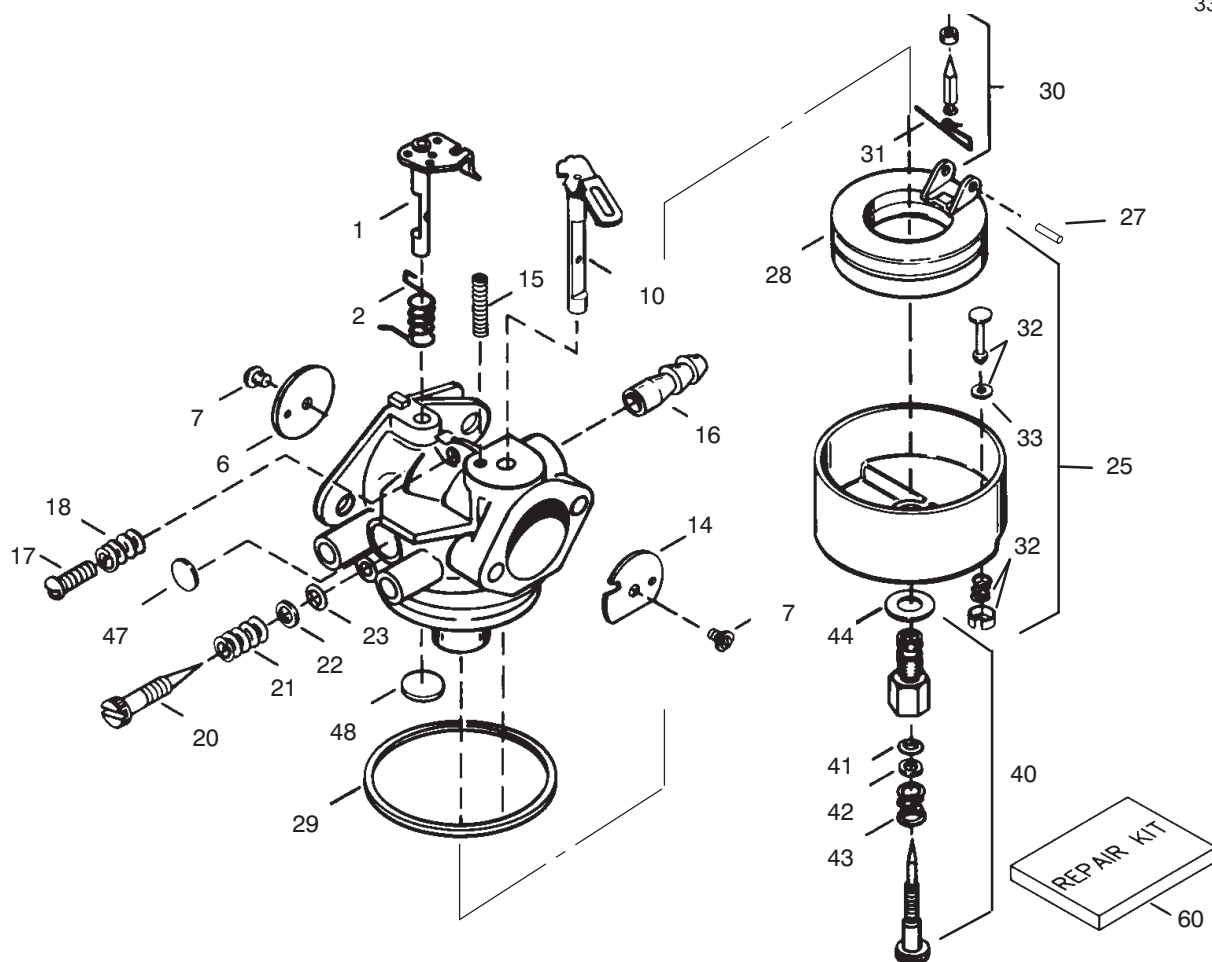

C-1744

CARBURETOR TECUMSEH NO. 632334A

Ref. No.	Part No.	Description	No. Used	Ref. No.	Part No.	Description	No. Used
1	631776A	Shaft/Lever – Throttle	1	28	632019	Float – Carburetor	1
2	631970	Spring – Throttle Return	1	*29	631028	Gasket – Bowl to Body	1
6	631778	Shutter – Throttle	1	*30	631021	Inlet Needle, Seat & Clip Asm (Incl. Ref. #31)	1
7	650506	Screw – Shutter	2	31	631022	Clip – Inlet Needle	1
10	632112	Shaft/Lever – Choke	1	32	27136A	Drain Assembly (Incl. Ref. #33)	1
14	632174	Shutter – Choke	1	33	27554	Gasket – Bowl Drain	1
15	630735	Spring – Choke Positioning	1	*40	632239	Adjustment Screw Asm (Incl. Ref. #43, 44, 41 & 42)	1
16	632164	Fitting – Fuel Inlet	1	41	630740	O-Ring – Adj. Screw	1
17	650417	Screw – Idle Regulating	1	42	630739	Washer – Adj. Screw	1
18	630766	Spring – Tension	1	43	630738	Spring – Adjustment Screw	1
*20	632281	Screw – Idle Adjustment	1	44	27110	Gasket – Bowl to Body	1
21	630766	Spring – Regulating Screw	1	*47	630748	Plug – Welch	1
22	630739	Washer – Flat	1	*48	631027	Plug – Welch	1
*23	630740	O-Ring – Adj. Screw	1	60	632347	Kit – Repair	1
25	631951	Float Bowl Assembly (Incl. Ref. #32 & 33)	1				
*27	631024	Shaft – Float	1				

*Included in Repair Kit Ref. #60.

ENGINE TECUMSEH MODEL NO. HMSK80-155386U

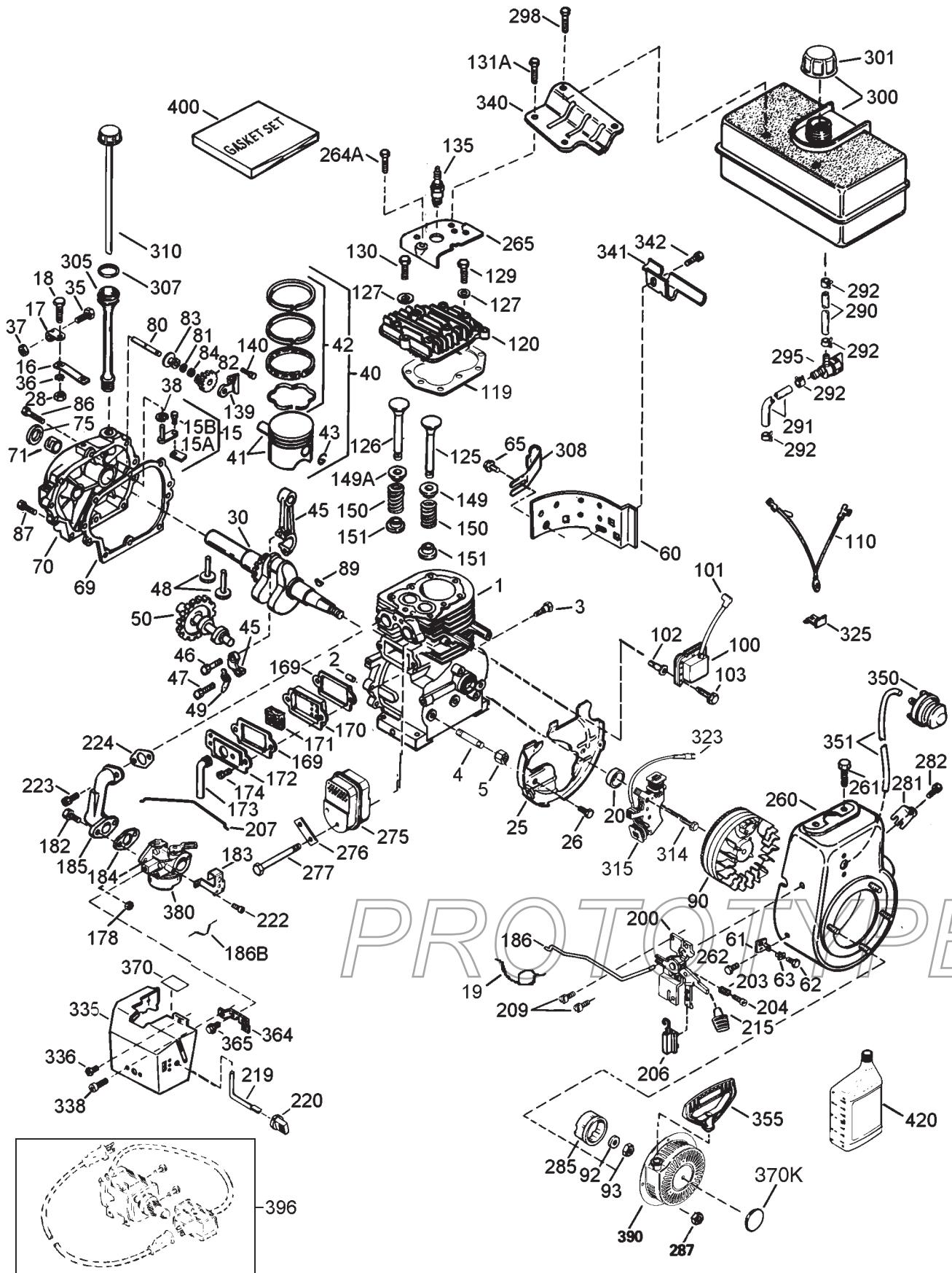

ENGINE TECUMSEH MODEL NO. HMSK80-155386U

Ref. No.	Part No.	Description	No. Used
1	35385	Cylinder Asm (Incl. Ref. #2, 20, & 72)	1
2	27652	Dowel Pin	2
3	650820	Screw	2
4	XXXXX	Oil Drain Extension	1
5	30969	Extension Cap	1
15	30699C	Governor (Incl. Ref. #15A & 15B)	1
15A	30700	Governor Yoke	1
15B	650494	Screw	1
16	33454	Governor Lever	1
17	29916	Governor Lever Clamp	1
18	650548	Screw	1
19	34663	Spring - Speed Control	1
20	35319	Oil Seal	1
25	36460	Blower Housing Baffle	1
26	650561	Screw	2
28	30322	Lock Nut	1
30	35571A	Crankshaft	1
35	29826	Screw	1
36	29918	Lock Washer	1
37	29216	Lock Nut	1
38	29642	Retaining Ring	1
40	34552	Piston, Pin & Ring Set (Std.)	1
40	34553	Piston, Pin & Ring Set (.010" OS)	1
40	34554	Piston, Pin & Ring Set (.020" OS)	1
41	34329A	Piston & Pin Asm (Std.) (Incl. Ref. #43)	1
41	34330A	Piston & Pin Asm (.010" OS) (Incl. Ref. #43)	1
41	34331A	Piston & Pin Asm (.020" OS) (Incl. Ref. #43)	1
42	34332	Ring Set (Std.)	1
42	34333	Ring Set (.010" OS)	1
42	34334	Ring Set (.020" OS)	1
43	27888	Piston Pin Retaining Ring	2
45	35373A	Connecting Rod Asm (Incl. Ref. #46, 47, & 49)	1
46	650908	Connecting Rod Bolt	1
47	650882	Connecting Rod Bolt	1
48	34034	Valve Lifter	2
49	35374	Oil Dipper	1
50	35375	Camshaft (MCR)	1
60	33273A	Blower Housing Extension	1
61	34126	Grommet Mounting Bracket	1
62	650760	Screw	1
63	28545	Grommet	1
65	650128	Screw	1
*69	35262A	Cylinder Cover Gasket	1
70	35376	Cylinder Cover (Incl. Ref. #71, 75, & 80)	1
71	35377	Crankshaft Bushing	1

Ref. No.	Part No.	Description	No. Used
75	35319	Oil Seal	1
80	31845	Governor shaft	1
81	30590A	Washer	1
82	35378	Governor Gear Asm (Incl. Ref. #81)	1
83	30588A	Governor Spool	1
84	29193	Retaining Ring	1
86	650833	Screw	7
87	650832	Screw	1
89	32589	Flywheel Key	1
90	611093	Flywheel (W/Ring Gear)	1
92	650880	Lock Washer	1
93	650881	Flywheel Nut	1
100	35135	Solid State Ignition	1
101	610118	Spark Plug Cover	1
102	650872	Solid State Mounting Stud	2
103	651007	Screw, Torx T-15	2
110	35253	Ground Wire	1
*119	36448	Cylinder Head Gasket	1
120	36449	Cylinder Head	1
125	27878A	Exhaust Valve (Std.) (Incl. Ref. #151)	1
125	27880A	Exhaust valve (1/32" OS) (Incl. Ref. #151)	1
126	34035	Intake Valve (Std.) (Incl. Ref. #151)	1
126	34036	Intake Valve (1/32" OS) (Incl. Ref. #151)	1
127	650691	Washer	2
129	650727	Screw	2
130B	6021A	Screw	7
131A	650713	Screw	2
135	35395	Resistor Spark Plug (RJ19LM)	1
139	33369	Governor Gear Bracket	1
140	650836	Screw	2
149	27882	Valve Spring Cap	1
149A	35862	Valve Spring Cap	1
150	27881	Valve Spring	2
151	32581	Valve Spring Keeper	2
*169	27896A	Valve Cover Gasket	2
170	28423	Breather Body	1
171	28424	Breather Element	1
172	28425	Valve Cover	1
173	35350	Breather Tube	1
174	650128	Screw	2
178	29752	Nut & Lock Washer	2
182	30088A	Screw	2
183A	34587	Choke Bracket	1
*184	33263	Carburetor To Intake Pipe Gasket	1
185	33877	Intake Pipe	1
186	34667	Governor Link	1
186A	36652	Spring - Choke	1

*Included in Gasket Set 36450

ENGINE TECUMSEH MODEL HMSK80-155386U (Cont.)

Ref. No.	Part No.	Description	No. Used
200	34677	Control Bracket (Incl. Ref.#19, 203, 204 & 206)	1
203	31342	Compression Spring	1
204	650549	Screw	1
206	610973	Terminal	1
207	33878	Throttle Link	1
209	650821	Screw	2
215	35440	Control Knob	1
219	34586	Choke rod	1
220	35438	Choke Knob	1
222	28820	Screw	2
223	650378	Screw, Torx T-30	2
*224	27915A	Intake Pipe Gasket	1
260	35447A	Blower Housing	1
261	650788	Screw	2
262	29747B	Screw, Torx T-40	2
264A	650802	Screw	1
265	33272B	Cylinder Head Cover	1
275	35056	Muffler	1
276	31588	Locking Plate	1
277	651002	Screw	2
281	33013	Starter bubble Cover	1
282	650760	Screw	1
285	35985B	Starter Cup	1
287	29752	Nut & Lock Washer	4
290	29774	Fuel Line	1
291	30705	Fuel Line	1
292	26460	Fuel Line Clamp	4
295	35857	Fuel shut-Off Valve	1
298	650665	Screw	2

Ref. No.	Part No.	Description	No. Used
300	34156A	Fuel Tank (Incl. Ref. #292 & 301)	1
301	36246	Fuel Cap	1
305	35554	Oil fill Tube	1
307	35499	"O" Ring	1
308	35540	Fill Tube Clip	1
310	36205	Dipstick	1
314	650873	Screw	1
315	611111	Alternator Coil (18 Watt) (Incl. Ref. #323)	1
323	611118	Terminal	1
325	29443	Wire Clip	1
335	35057A	Carburetor Cover	1
336	650765	Screw	1
338	28942	Screw	2
340	34155	Fuel Tank Bracket	1
341	34154	Fuel Tank Bracket	1
342	650561	Screw	1
350	570682	Primer Bulb	1
351	32180C	Primer Line	1
355	590574	Starter Handle	1
364	33377	Carburetor Cover Bracket	1
365	650767	Screw	2
370	36261	Identification Decal	1
370K	36695	Starter Decal	1
380	632334A	Carburetor (Incl. Ref. #184)	1
390	590733	Rewind Starter	1
396	33329D	Electric Starter Motor, 120 Volt (Optional)	1
400	36450A	Gasket Set	1
420	730226	SAE 5W30 4-Cyc. Eng. Oil	1

PROTOTYPE

*Included in Gasket Set 36450

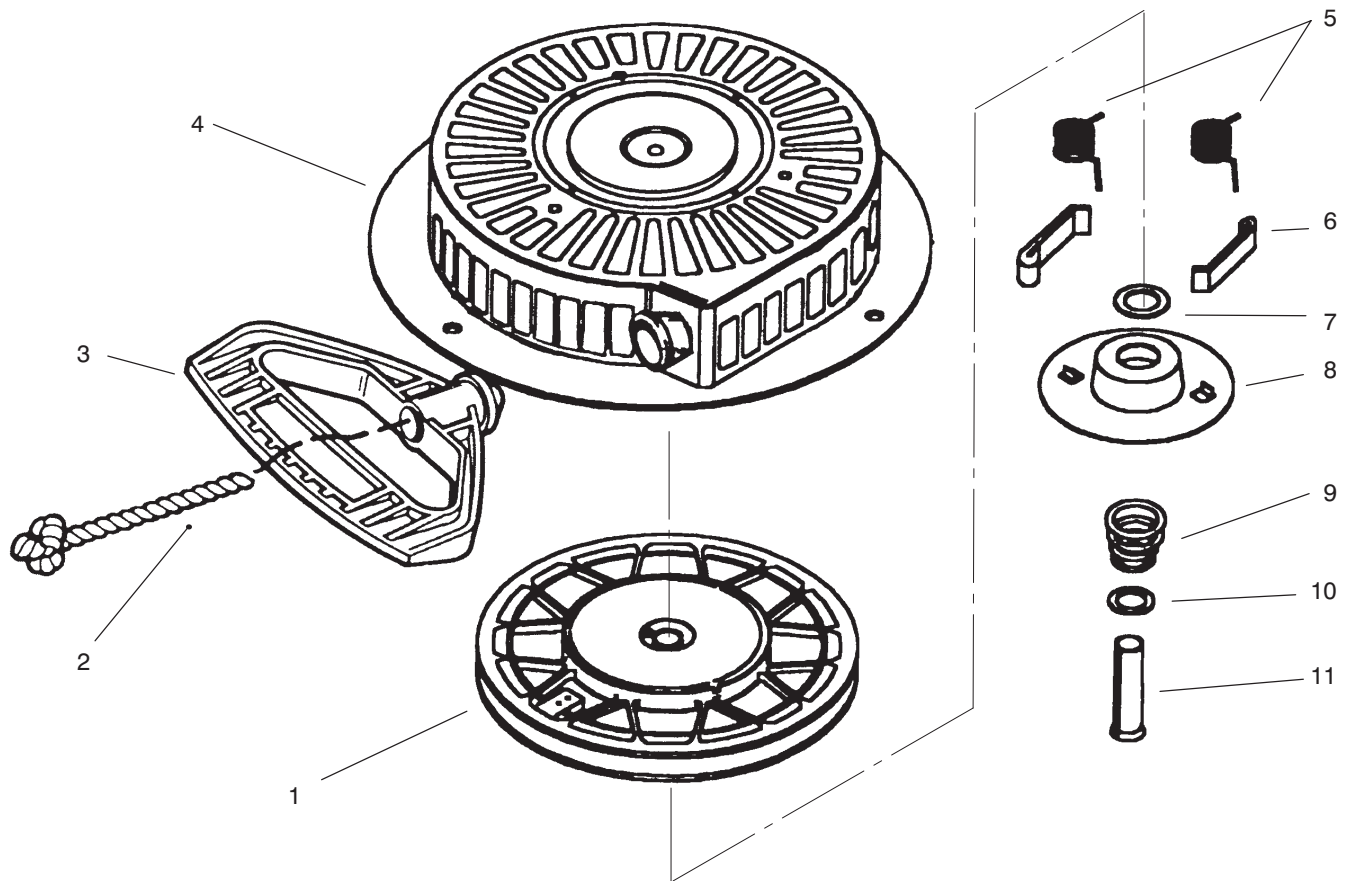

REWIND STARTER TECUMSEH NO. 590733

Ref. No.	Part No.	Description	No. Used
1	590709	Pulley & Rewind Spring Assembly	1
2	590535	Rope – Starter	1
‡3	590574	Handle – Mitten Grip	1
4	590534	Starter Housing Asm	1
5	590699	Spring – Dog	2
6	590698	Dog – Starter	2

Ref. No.	Part No.	Description	No. Used
7	590601	Washer	1
8	590676	Retainer	1
9	590697	Spring – Brake	1
10	590600	Washer	1
11	590599A	Pin – Spring (Incl. Ref. #7)	1

PROTOTYPE

‡Not Included in Starter Assembly.

TORO PART NUMBER INDEX

3318-660

Part No.	Description	Pg. No.	Ref. No.	Qty.	Part No.	Description	Pg. No.	Ref. No.	Qty.
3-0750	Washer - Retaining	1	2	2	62-1140	Cover - Latch	8	12	1
3-4244	Pulley - Idler	7	6	2	62-1150	Bushing - Worm	3	16	1
5-2490	Bolt - Shoulder	7	35	2	62-1160	Bushing - Intermediate	6	46	4
7-0045	Seal - Oil	3	2	2	62-1170	Bushing - Flange	5	38	2
11-0590	Screw - Hex. Hd.	4	23	4	62-1180	Bushing - Output (Flange)	5	1	1
12-3270	Screw	6	49	3	62-1190	Bracket - Bellcrank	5	22	1
12-8789	Impeller Bearing Assembly	2	*	1	62-1230	Washer - Rubber	9	33	1
13-3559	Gear - Bevel Reverse 36T	6	59	1	62-1290	Knob - Shift	8	1	1
17-4249	Loose Parts Kit	10	*	1	62-1300	Pulley - Impeller	1	24	1
17-4299	Loose Parts Kit	10	*	1	62-1310	Pulley - Traction	6	50	1
20-0980	Bearing - Auger	2	57	2	62-1320	Knob - Chute Control	9	17	1
20-0990	Flange - Bearing (Inner)	2	56	2	62-1330	Bolt - Shoulder	7	24	2
20-1000	Flange - Bearing (Outer)	2	58	2	62-1350	Bushing - Output	5	27	2
25-5090	Spacer - Auger Hub	2	55	2	62-1380	Handle - R.H.	9	9	1
26-6110	Flange - Bearing (Front)	2	38	1	62-1430	Retainer - Chute	1	11	3
26-6120	Flange - Bearing (Rear)	2	40	1	62-1440	Cover - Engine Frame	2	32	1
29-9570	Bushing - Yoke	6	45	1	62-1460	Gear - Universal	9	32	2
32-251-1	Washer - Flat	4	28	2	62-1470	Base - Lockout	8	42	1
36-180	Washer - Lock	4	29	2	62-1490	Plate - Guide	9	15	1
37-6560	Bushing - Input	3	10	1	62-1520	Cover - Knob	9	19	1
38-7820	Bearing - Ball	5	36	2	62-1530	Shaft - Auger 24	3	1	1
40-5940	Switch - On/Off	9	21	1	62-1640	Lever - Trip	9	12	1
42-671	Screw - Self Tapping	4	30	2	62-1650	Spring - Torsion	8	6	1
52-2861	Washer	2	43	4	62-1690	Cover - Detent	5	11	1
53-7670	Decal - Danger Auger	1	5	1	62-1700	Lever - Lockout	8	19	1
62-0120	Gear - Helical	3	15	1	62-1710	Spring - Flat	8	16	1
62-0170	Wheel - Index	8	41	1	62-1720	Rod - Chute Gear	1	23	1
62-0180	Tang - Index	8	5	1	62-1740	Bracket - Cable	5	7	1
62-0200	Gear - 27T	5	31	1	63-2030	Rod - Cross	9	27	1
62-0210	Gear - 33T	5	43	1	63-2080	Cover - Belt (Upper)	1	28	1
62-0220	Gear - 34T	5	30	1	63-2111	Axle Assembly	7	29	1
62-0240	Gear - 45T	5	29	1	63-2150	Frame - Control	8	23	1
62-0250	Gear - 29T	5	32	1	63-2160	Rod - Chute Crank	9	16	1
62-0260	Gear - 51T	5	42	1	63-2170	Cover - Lever Lock	9	1	1
62-0280	Latch - Lock	9	6	1	63-2180	Bracket - Gear	1	7	1
62-0290	Cam - Release	9	4	1	63-2190	Pin - Gearshift Link	5	15	1
62-0300	Tang - Locking	9	3	1	63-2200	Cable - Latch	8	39	1
62-0310	Key - Shift	6	56	2	63-2210	Cable - Gearbox	8	38	1
62-0320	Sleeve	5	28	1	63-2220	Spring - Extension	8	8	1
62-0330	Shaft - Intermediate	5	40	1	63-2230	Spring - Extension	8	21	1
62-0340	Sleeve - Gear 19T	5	34	1	63-2240	Spring - Extension	8	17	1
62-0350	Pinion - Bevel 19T	6	53	1	63-2250	Bushing - Axle	7	26	2
62-0360	Gear - Compound 19T/41T	5	41	1	63-2270	Spring - Torsion	8	40	1
62-0370	Gear - 41T	5	35	1	63-2280	Washer - Thrust	5	33	1
62-0380	Hub - Pulley	6	52	1	63-2300	Retainer - Cable	1	26	1
62-0430	Collar - Shift (Speed)	5	3	1	63-2410	Decal - Choke	4	12	1
62-0470	Latch - Arm	7	17	1	63-2450	Decal - Throttle	4	11	1
62-0480	Gear Case - Lower	5	44	1	63-2480	Decal - #2	8	10	1
62-0490	Gear Case - Upper	5	24	1	63-2510	Decal - Panel Front	9	36	1
62-0500	Gear - 15T	6	48	1	63-2600	Beltcrank	5	20	1
62-0720	Housing - 24	1	6	1	63-2610	Pin - Tang	8	9	1
62-0820	Gear - Worm	1	22	1	63-2630	Bracket - Shift	8	33	1
62-0840	Chute Assembly	1	19	1	63-2650	Screw - Shoulder	8	18	2
62-0860	Link - Gearshift	5	18	1	63-2670	Plate - Chute Retainer	1	10	3
62-0870	Lever - Gear Shift	5	16	1	63-2700	Cable - Impeller	10	41	1
62-0880	Lever - Direction Shift	5	5	1	63-2710	Cable - Traction	10	40	1
62-0920	Sheave Half - Traction	4	7	1	63-2740	Spring - Torsion	7	36	1
62-0930	Hub - Sheave	4	5	1	63-2810	Arm - Brake	7	2	1
62-0940	Sheave Half - Impeller	4	3	1	63-2830	Rod - Shift (Lower)	8	34	1
62-0970	Pin - Idler	7	9	1	63-2850	Bracket - Idler Arm	7	3	1
62-1000	Guard - Chain R.H.	7	30	1	63-2870	Spring - Extension	7	14	2
62-1010	Guard - Chain L.H.	7	28	1	63-2880	Spring - Torsion	7	13	1
62-1020	Button - Detent	5	10	1	63-2890	Spring - Compression	5	9	1
62-1040	Yoke-Shift	5	26	2	63-2900	Washer - Plastic	1	17	2
62-1050	Lever - Impeller	9	8	1	63-2910	Spring - Torsion	9	7	1
62-1060	Lever - Traction	9	24	1	63-2920	Spring - Extension	5	4	1
62-1070	Bushing - Lever	9	11	2	63-2940	Chain - Drive	4	19	1
62-1080	Shaft - Output	5	37	1	63-2951	Belt - Traction	4	6	1
62-1100	Lever - Latch	8	7	1	63-2961	Belt - Impeller	4	4	1
62-1110	Lever - Index Wheel	8	3	1	63-2990	Frame - Transmission	4	21	1
62-1120	Lever - Reverse	8	22	1	63-3020	Guard - Chute	1	14	1
62-1130	Lever - Reverse	8	20	1	63-3050	Decal - Lever	9	25	1

*Not Illustrated

TORO PART NUMBER INDEX (Cont.)

Part No.	Description	Pg. No.	Ref. No.	Qty.	Part No.	Description	Pg. No.	Ref. No.	Qty.
63-3130	Clip - Chute Guard	1	12	1	257-10	Washer - Thrust	5	39	4
63-3290	Cover - Cable	1	29	1	281-1	Plug - Pipe Sq. Hd.	3	14	1
63-3340	Washer	7	22	4	283-3	Pin - Clevis	5	19	1
63-3380	Spacer - Traction Lever	9	22	1	321-3	Screw - Hex. Hd.	2	60	8
63-3410	Bolt - Shoulder	5	13	1	321-9	Screw - Hex. Hd.	8	29	1
63-3420	Harness - Wire	10	*	1	321-15	Screw - Hex. Hd.	6	54	1
63-3450	Bearing - Impeller	2	39	1	321-44	Screw - Hex. Hd.	2	52	2
63-8360	Key - Switch	9	20	1	322-12	Bolt - Auger	2	59	2
66-6840	Decal - Hot Surface	4	14	1	323-6	Screw - Hex. Hd.	1	1	2
66-6850	Decal - Panel Top	9	14	1	323-7	Screw - Hex. Hd.	7	8	2
66-6860	Decal - Warning	10	38	1	3210-1	Screw - Hex. Hd.	4	25	2
66-6860	Decal - Warning	7	40	1	3212-8	Screw - Hex. Hd.	4	1	1
66-6980	Frame - Engine	2	31	1	3220-3	Nut - Jam	4	26	1
66-7720	Rod - Latch	7	18	1	3220-3	Nut - Jam	8	35	1
66-7730	Clevis	8	30	1	3230-2	Bolt - Carriage	1	8	1
66-7740	Pivot Arm Assembly	7	23	2	3230-23	Screw - Carriage	2	48	9
66-7762	Blade - Scraper	2	45	1	3234-5	Screw - Hex.. Washer Hd.	2	33	4
66-7811	Shaft - Impeller	3	6	1	3234-7	Screw	2	61	6
66-7821	Plate - Side R.H.	1	3	1	3234-7	Screw - Hex. Flange Hd.	4	16	4
66-7831	Plate - Side L.H.	2	46	1	3234-7	Screw - Hex. Flange Hd.	9	26	6
66-7850	Handlegrip	9	10	2	3234-7	Screw - Hex. Flange Hd.	7	41	2
66-7910	Impeller	2	50	1	3234-13	Screw - Hex. Washer Hd.	7	5	1
66-8010	Spacer	2	51	2	3234-28	Screw - Hex. Flange Hd.	1	4	12
66-8030	Transmission Assembly	4	20	1	3242-4	Screw - Set Sq. Hd.	1	25	2
66-8060	Pad - Brake	7	42	1	3253-4	Washer - Lock	4	24	2
66-8090	Handle - L.H.	9	29	1	3253-6	Washer - Lock	4	2	1
66-8100	Panel - Control	9	13	1	3256-1	Washer - Flat	7	21	2
67-5870	Gear - Bevel 36T	6	57	1	3256-1	Washer - Flat	8	27	2
67-5880	Collar - Shift	6	58	1	3256-14	Washer - Flat	1	16	1
67-9220	Tire & Wheel Assembly	7	34	2	3256-14	Washer - Flat	10	42	2
67-9240	Rod - Shift (Upper)	8	2	1	3256-23	Washer - Flat	8	24	3
67-9250	Retainer - Shift Rod	8	28	1	3256-23	Washer - Flat	2	42	1
68-4100	Plate - Engine Stud R.H.	2	*	1	3256-38	Washer - Flat	7	12	1
68-4110	Plate - Engine Stud L.H.	2	34	1	3256-41	Washer	4	32	1
68-4310	Gear - 26T	6	47	1	3256-61	Washer - Flat	1	21	1
68-4320	Sleeve - Shift	6	55	1	3257-10	Key - Woodruff	3	12	1
68-7450	Auger - R.H.	2	54	1	3257-23	Key - Woodruff	2	35	1
68-7460	Auger - L.H.	2	*	1	3269-23	Rivet	1	30	4
68-7510	Guide - Belt	4	8	1	3272-1	Pin - Cotter	5	17	1
68-8410	Cover - Belt (Lower)	2	41	1	3274-13	Screw - Machine	1	13	3
74-1440	Skid Assembly	2	44	2	3290-243	Pin - Klik	7	38	2
74-1540	Gearcase Assembly - L.H.	3	13	1	3290-320	Nut - Push	8	15	1
74-1550	Gearcase Assembly - R.H.	3	4	1	3290-320	Nut - Push	9	18	2
74-1560	Auger Gearbox Assembly	2	53	1	3290-326	Nut - Push	1	15	2
78-2920	Joint - Ball	8	36	1	3290-359	Screw	9	28	1
78-2920	Joint - Ball	4	17	1	3290-378	Tie - Cable	9	30	3
88-0810	Spring - Extension	10	39	1	3290-422	Nut - Push	8	4	1
93-1265	Decal - Hot Surface	4	14	1	3290-456	Washer - Belleville	8	37	1
93-8045	Arm - Traction Idler	7	10	1	3290-461	Washer - Belleville	7	16	2
93-8046	Arm - Impeller Idler	7	11	1	3290-461	Washer - Belleville	4	22	4
94-2559	Decal - Danger Chute	1	*	1	3290-476	Fastener - Panel	7	37	1
94-2568	Decal - Danger Auger	1	*	1	3290-477	Washer - Curved	5	14	1
94-2572	Decal - Primer	4	10	1	3296-2	Nut - Lock	1	9	4
94-2575	Decal - Warning	10	*	1	3296-2	Nut - Lock	9	23	1
94-2575	Decal - Warning	7	*	1	3296-6	Nut - Lock	4	18	1
94-2578	Decal - Panel Top	9	*	1	3296-6	Nut - Lock	8	32	1
94-2782	Cap - Wire	4	31	1	3296-23	Nut - Lock	7	25	2
94-6961	Screw - Pan Hd.	8	11	2	3296-29	Nut - Lock	8	25	7
94-6961	Screw - Pan Hd.	9	35	2	3296-29	Nut - Lock	2	37	14
94-8079	Decal - Danger Chute	1	20	1	3296-39	Nut - Lock	7	15	2
127-20	Guard - Muffler	4	27	1	3296-42	Nut - Lock	7	4	1
2210-250	Screw	9	2	3	3296-42	Nut - Lock	5	23	1
252-59	Washer - Thrust	5	2	3	3296-42	Nut - Lock	8	26	1
252-71	Bearing - Thrust	3	5	2	3296-42	Nut - Lock	2	49	10
252-76	Bearing - Thrust	3	9	1	3296-47	Nut - Lock	9	37	4
252-78	Washer - Thrust	3	8	2	3296-47	Nut - Lock	7	39	2
252-80	Washer - Thrust	7	27	4	3296-47	Nut - Lock	2	47	20
252-80	Washer - Thrust	2	36	1	3296-59	Nut - Lock	7	7	2
253-149	Seal - Input	3	11	1	32104-71	Screw - Pan Hd.	5	12	1
256-237	Bushing - Sleeve	3	3	2	32104-76	Screw - Self Tapping	9	34	2
256-296	Bushing - Nyliner	8	31	2	32104-95	Screw - Hex. Washer Hd.	5	21	2
257-9	Washer - Thrust	8	14	1	32104-121	Screw - Hex. Flange Hd.	7	31	3

*Not Illustrated

TORO PART NUMBER INDEX (Cont.)

3318-660

Part No.	Description	Pg. Ref. No. No. Qty.	Part No.	Description	Pg. Ref. No. No. Qty.
32120-46	Ring - Retaining	7 1 2	32151-33	Ring - Snap	3 7 1
32120-46	Ring - Retaining	8 13 1	32151-66	Ring - Retaining	9 5 1
32121-9	Pin - Roll	7 19 2	505-101	Grease - 14.5 oz. Cartridge	6 * 1
32121-50	Pin - Roll	9 31 2	505-129	Sealant - 100g Tube	3 * 1
32121-106	Pin - Coil	5 6 3			
32121-120	Roll - Pin	6 60 2			
32122-32	Screw	1 18 1			
32128-20	Nut - Lock	4 15 4			
32128-32	Nut - Flange Lock	6 51 1			
32144-4	Screw	4 13 1			
32144-4	Screw - Hex. Flange Hd.	7 20 2			
32144-4	Screw - Hex. Flange Hd.	1 27 5			
32144-4	Screw - Self Tapping	5 8 2			
32144-86	Screw - Hex. Washer Hd.	5 25 6			
32144-110	Screw - Hex. Washer Hd.	3 17 9			

OPTIONAL EQUIPMENT

110 Vac Electric Starter Kit	Part No. 37-4810
Drift Breaker	Part No. 66-7960
Light Kit	Part No. 66-7941
Tire Chain Kit (Do Not Use W/68-9300)	Part No. 56-2700
Snow Cab Kit	Part No. 68-9500
Weight Kit (Required W/Snow Cab) . . .	Part No. 74-1190
Differential Kit	Part No. 68-9300

PROTOTYPE

*Not Illustrated

