



Count on it.

Operator's Manual

**Greensmaster® 3250-D 2-Wheel
Drive Traction Unit**

Model No. 04383—Serial No. 311000001 and Up



This product complies with all relevant European directives, for details please see the separate product specific Declaration of Conformity (DOC) sheet.

WARNING

CALIFORNIA Proposition 65 Warning

Diesel engine exhaust and some of its constituents are known to the State of California to cause cancer, birth defects, and other reproductive harm.

Important: This engine is not equipped with a spark arrester muffler. It is a violation of California Public Resource Code Section 4442 to use or operate the engine on any forest-covered, brush-covered, or grass-covered land. Other states or federal areas may have similar laws.

Introduction

This machine is a ride-on, reel-blade lawnmower intended to be used by professional, hired operators in commercial applications. It is primarily designed for cutting grass on well-maintained lawns in parks, golf courses, sports fields, and on commercial grounds. It is not designed for cutting brush, mowing grass and other growth alongside highways, or for agricultural uses.

Read this information carefully to learn how to operate and maintain your product properly and to avoid injury and product damage. You are responsible for operating the product properly and safely.

You may contact Toro directly at www.Toro.com for product and accessory information, help finding a dealer, or to register your product.

Whenever you need service, genuine Toro parts, or additional information, contact an Authorized Service Dealer or Toro Customer Service and have the model and serial numbers of your product ready. [Figure 1](#) identifies the location of the model and serial numbers on the product. Write the numbers in the space provided.

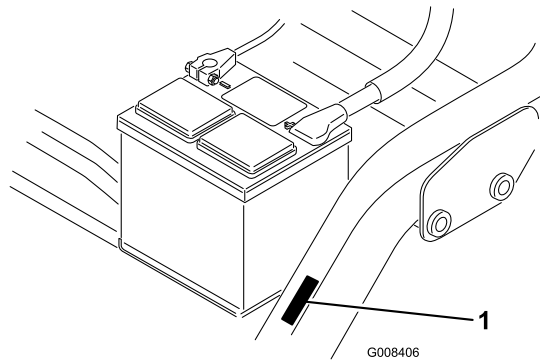

Figure 1

1. Model and serial number location

Model No. _____

Serial No. _____

This manual identifies potential hazards and has safety messages identified by the safety alert symbol ([Figure 2](#)), which signals a hazard that may cause serious injury or death if you do not follow the recommended precautions.



Figure 2

1. Safety alert symbol

This manual also uses 2 words to highlight information. **Important** calls attention to special mechanical information and **Note** emphasizes general information worthy of special attention.

Contents

Safety	4	Adjusting the Throttle Control	36
Safe Operating Practices	4	Adjusting the Idle Speed	37
Toro Mower Safety	5	Fuel System Maintenance	37
Sound Power Level	7	Fuel Filter/Water Separator	37
Sound Pressure Level	7	Fuel Lines and Connections	38
Vibration Level	7	Electrical System Maintenance	38
Safety and Instructional Decals	7	Servicing the Battery	38
Setup	11	Storing the Battery	39
1 Installing the Rear Wheel	12	Fuses	39
2 Mounting the Seat	12	Drive System Maintenance	40
3 Activating and Charging the Battery	13	Adjusting the Transmission for Neutral	40
4 Installing the Battery	14	Adjusting the Transport Speed	40
5 Mounting the Front Rollers	15	Adjusting the Mowing Speed	40
6 Adjusting the Carrier Frame Rollers	15	Cooling System Maintenance	41
7 Optional Oil Cooler	16	Cleaning the Radiator Screen	41
8 Installing the Cutting Units (<i>For Cutting Unit</i> <i>Models 04610, 04611 and 04616 Only</i>)	16	Brake Maintenance	42
9 Adjusting the Transport Height	19	Adjusting the Brakes	42
10 Adding Rear Ballast	20	Belt Maintenance	42
11 Install EU Decals	20	Adjusting the Belt	42
12 Reading the Manuals and Viewing the Training Materials	20	Controls System Maintenance	43
Product Overview	21	Adjusting the Cutting Unit Lift/Drop	43
Controls	21	Backlapping	43
Specifications	23	Hydraulic System Maintenance	44
Attachments/Accessories	23	Changing the Hydraulic Oil and Filter	44
Operation	24	Checking the Hydraulic Lines and Hoses	45
Think Safety First	24	Storage	45
Checking the Engine Oil	24	Schematics	46
Filling the Fuel Tank	25		
Checking the Cooling System	26		
Checking the Hydraulic Fluid Level	26		
Draining Water from the Fuel Filter	28		
Checking the Tire Pressure	28		
Checking the Reel-to-Deckknife Contact	28		
Checking the Torque of the Wheel Nuts	28		
Break-in Period	28		
Starting and Stopping the Machine	28		
Bleeding the Fuel System	29		
Checking the Safety Interlock System	29		
Setting the Reel Speed	30		
Preparing the Machine for Mowing	30		
Training Period	31		
Before Mowing	31		
Mowing Procedures	31		
Transport Operation	32		
Inspection and Cleanup After Mowing	32		
Towing the Machine	32		
Maintenance	33		
Recommended Maintenance Schedule(s)	33		
Daily Maintenance Checklist	34		
Lubrication	35		
Greasing the Bearings and Bushings	35		
Engine Maintenance	36		
Servicing the Air Cleaner	36		
Changing the Engine Oil and Filter	36		

Safety

This machine meets or exceeds CEN standard EN 836:1997, ISO standard 5395:1990, and ANSI B71.4-2004 specifications in effect at the time of production when 40 lb. of ballast is added to the rear wheel.

Improper use or maintenance by the operator or owner can result in injury. To reduce the potential for injury, comply with these safety instructions and always pay attention to the safety alert symbol (Figure 2), which means Caution, Warning, or Danger—personal safety instruction. Failure to comply with the instruction may result in personal injury or death.

Safe Operating Practices

The following instructions are from CEN standard EN 836:1997, ISO standard 5395:1990, and ANSI B71.4-2004.

Training

- Read the *Operator's Manual* and other training material carefully. Be familiar with the controls, safety signs, and the proper use of the equipment.
- If the operator or mechanic can not read the language of this manual, it is the owner's responsibility to explain this material to them.
- Never allow children or people unfamiliar with these instructions to use or service the mower. Local regulations may restrict the age of the operator.
- Never mow while people, especially children, or pets are nearby.
- Keep in mind that the operator or user is responsible for accidents or hazards occurring to other people or their property.
- Do not carry passengers.
- All drivers and mechanics should seek and obtain professional and practical instruction. The owner is responsible for training the users. Such instruction should emphasize:
 - the need for care and concentration when working with ride-on machines;
 - control of a ride-on machine sliding on a slope will not be regained by the application of the brake. The main reasons for loss of control are:
 - ◇ insufficient wheel grip;
 - ◇ being driven too fast;
 - ◇ inadequate braking;
 - ◇ the type of machine is unsuitable for the task;
 - ◇ lack of awareness of the effect of ground conditions, especially slopes.
 - ◇ The owner/user can prevent and is responsible for accidents or injuries occurring to himself or herself, other people, or property

Preparation

- While mowing, always wear substantial footwear, long trousers, hard hat, safety glasses, and hearing protection. Long hair, loose clothing, or jewelry may get tangled in moving parts. Do not operate the equipment when barefoot or wearing open sandals.
- Thoroughly inspect the area where the equipment is to be used and remove all objects which may be thrown by the machine.
- **Warning**—Fuel is highly flammable. Take the following precautions:
 - Store fuel in containers specifically designed for this purpose.
 - Refuel outdoors only and do not smoke while refueling.
 - Add fuel before starting the engine. Never remove the cap of the fuel tank or add fuel while the engine is running or when the engine is hot.
 - If fuel is spilled, do not attempt to start the engine but move the machine away from the area of spillage and avoid creating any source of ignition until fuel vapors have dissipated.
 - Replace all fuel tank and container caps securely.
- Replace faulty silencers/mufflers.
- Evaluate the terrain to determine what accessories and attachments are needed to properly and safely perform the job. Only use accessories and attachments approved by the manufacturer.
- Check that operator's presence controls, safety switches and shields are attached and functioning properly. Do not operate unless they are functioning properly.

Operation

- Do not operate the engine in a confined space where dangerous carbon monoxide fumes can collect.
- Mow only in daylight or in good artificial light.
- Before attempting to start the engine, disengage all blade attachment clutches, shift into neutral, and engage the parking brake.
- Remember there is no such thing as a safe slope. Travel on grass slopes requires particular care. To guard against overturning:
 - do not stop or start suddenly when going up or downhill;
 - machine speeds should be kept low on slopes and during tight turns;
 - stay alert for humps and hollows and other hidden hazards;
 - never mow across the face of the slope, unless the mower is designed for this purpose.
- Stay alert for holes in the terrain and other hidden hazards.
- Watch out for traffic when crossing or near roadways.

- Stop the blades from rotating before crossing surfaces other than grass.
- When using any attachments, never direct discharge of material toward bystanders nor allow anyone near the machine while in operation.
- Never operate the machine with damaged guards, shields, or without safety protective devices in place. Be sure all interlocks are attached, adjusted properly, and functioning properly.
- Do not change the engine governor settings or overspeed the engine. Operating the engine at excessive speed may increase the hazard of personal injury.
- Before leaving the operator's position:
 - stop on level ground;
 - disengage the power take-off and lower the attachments;
 - change into neutral and set the parking brake;
 - stop the engine and remove the key.
- Disengage drive to attachments when transporting or not in use.
- Stop the engine and disengage drive to attachment:
 - before refuelling;
 - before removing the grass catcher/catchers;
 - before making height adjustment unless adjustment can be made from the operator's position.
 - before clearing blockages;
 - before checking, cleaning or working on the mower;
 - after striking a foreign object or if an abnormal vibration occurs. Inspect the mower for damage and make repairs before restarting and operating the equipment.
- Reduce the throttle setting before stopping the engine and, if the engine is provided with a fuel shut-off valve, turn the fuel off at the conclusion of mowing.
- Keep hands and feet away from the cutting units.
- Look behind and down before backing up to be sure of a clear path.
- Slow down and use caution when making turns and crossing roads and sidewalks. Stop the reels when not mowing.
- Do not operate the mower under the influence of alcohol or drugs.
- Lightning can cause severe injury or death. If lightning is seen or thunder is heard in the area, do not operate the machine; seek shelter.
- Use care when loading or unloading the machine into a trailer or truck.
- Use care when approaching blind corners, shrubs, trees, or other objects that may obscure vision.

Maintenance and Storage

- Keep all nuts, bolts and screws tight to be sure the equipment is in safe working condition.
- Never store the equipment with fuel in the tank inside a building where fumes may reach an open flame or spark.
- Allow the engine to cool before storing in any enclosure.
- To reduce the risk fire hazard, keep the engine, silencer/muffler, battery compartment, and fuel storage area free of grass, leaves, or excessive grease.
- Replace worn or damaged parts for safety.
- Check the grass catcher frequently for wear or deterioration.
- Keep all parts in good working condition and all hardware and hydraulic fittings tightened. Replace all worn or damaged parts and decals.
- If the fuel tank has to be drained, do this outdoors.
- Be careful during adjustment of the machine to prevent entrapment of the fingers between moving blades and fixed parts of the machine.
- On multi-reel machines, take care as rotating one reel can cause other reels to rotate.
- Disengage drives, lower the cutting units, set parking brake, stop engine and remove key. Wait for all movement to stop before adjusting, cleaning or repairing.
- Clean grass and debris from cutting units, drives, mufflers, and engine to help prevent fires. Clean up oil or fuel spillage.
- Use jack stands to support components when required.
- Carefully release pressure from components with stored energy.
- Disconnect battery before making any repairs. Disconnect the negative terminal first and the positive last. Reconnect positive first and negative last.
- Use care when checking the reels. Wrap the reels or wear gloves, and use caution when servicing them.
- Keep hands and feet away from moving parts. If possible, do not make adjustments with the engine running.
- Charge batteries in an open well ventilated area, away from spark and flames. Unplug charger before connecting or disconnecting from battery. Wear protective clothing and use insulated tools.

Toro Mower Safety

The following list contains safety information specific to Toro products or other safety information that you must know that is not included in the ANSI standards.

This product is capable of amputating hands and feet and throwing objects. Always follow all safety instructions to avoid serious injury or death.

Use of this product for purposes other than its intended use could prove dangerous to user and bystanders.

Operation

- Know how to stop the engine quickly.
- Always wear substantial shoes. Do not operate the machine while wearing sandals, tennis shoes, or sneakers. Wearing safety shoes and long pants is advisable and required by some local ordinances and insurance regulations.
- The operator must be skilled and trained in how to drive on hillsides. Failure to use caution on slopes or hills may cause loss of control and cause the vehicle to tip or roll, possibly resulting in personal injury or death.
- Handle fuel carefully. Wipe up any spills.
- Check the safety interlock switches daily for proper operation. If a switch should fail, replace the switch before operating the machine
- Before attempting to start the engine, sit on the seat, depress the lift pedal, and release it to ensure the cutting units disengaged. Verify that the traction system is in neutral and the parking brake is set.
- Using the machine demands attention. To prevent loss of control:
 - Do not drive close to sand traps, ditches, creeks, or other hazards.
 - Reduce speed when making sharp turns. Avoid sudden stops and starts.
 - Watch out for traffic when near or crossing roads. Always yield the right-of-way.
 - Apply the service brakes when going downhill to keep forward speed slow and to maintain control of the machine.
- The grass baskets must be in place during operation of the reels or thatchers for maximum safety. Shut the engine off before emptying the baskets.
- Raise the cutting units when driving from one work area to another.
- Do not touch the engine, muffler, or exhaust pipe while the engine is running or soon after it has stopped because these areas could be hot enough to cause burns.
- Stay clear of the rotating screen at the side of the engine to prevent direct contact with your body or clothing.
- If the engine stalls or loses headway and cannot make it to the top of a slope, do not turn the machine around. Always back slowly, straight down the slope.
- Before getting off of the seat, move the functional control lever to neutral (N), raise the cutting units and wait for the reels to stop spinning. Set the parking brake. Stop the engine and remove the key from the ignition switch.
- Traverse slopes carefully. Do not start or stop suddenly when traveling uphill or downhill.

- The operator must be skilled and trained in how to drive on hillsides. Failure to use caution on slopes or hills may cause loss of control and cause the machine to tip or roll, possibly resulting in personal injury or death.
- If the engine stalls or loses headway and cannot make it to the top of a slope, do not turn the machine around. Always back slowly, straight down the slope.
- When a person or pet appears unexpectedly in or near the mowing area, **stop mowing**. Careless operation, combined with terrain angles, ricochets, or improperly positioned guards can lead to thrown object injuries. Do not resume mowing until the area is cleared.
- If the machine is equipped with an optional ROPS (Roll Over Protection System), always use the seat belt when operating the machine.
- Before getting off of the seat, move the functional control lever to neutral (N), raise the cutting units and wait for the reels to stop spinning. Set the parking brake. Stop the engine and remove the key from the ignition switch.
- Whenever the machine is left unattended, make sure the cutting units are fully raised, the reels are not spinning, the key is removed from the ignition switch, and the parking brake is set.

Maintenance and Storage

- Make sure all hydraulic line connectors are tight and all hydraulic hoses and lines are in good condition before applying pressure to the system.
- Keep your body and hands away from pin hole leaks or nozzles that eject hydraulic fluid under high pressure. Use paper or cardboard, not your hands, to search for leaks. Hydraulic fluid escaping under pressure can have sufficient force to penetrate the skin and cause serious injury.
- Before disconnecting or performing any work on the hydraulic system, all pressure in the system must be relieved by stopping the engine and lowering the cutting units and attachments to the ground.
- Check all fuel lines for tightness and wear on a regular basis. Tighten or repair them as needed.
- If the engine must be running to perform a maintenance adjustment, keep hands, feet, clothing, and any parts of the body away from the cutting units, attachments, and any moving parts, especially the screen at the side of the engine. Keep everyone away.
- To ensure safety and accuracy, have an Authorized Toro Distributor check the maximum engine speed with a tachometer. Maximum governed engine speed should be 2900 RPM.
- The engine must be shut off before checking the oil or adding oil to the crankcase.
- If major repairs are ever needed or if assistance is desired, contact an Authorized Toro Distributor.
- To ensure optimum performance and continued safety certification of the machine, use only genuine Toro

replacement parts and accessories. Replacement parts and accessories made by other manufacturers could be dangerous, and such use could void the product warranty.

Sound Power Level

This unit has a guaranteed sound power level of 99 dBA, which includes an Uncertainty Value (K) of 1 dBA.

Sound power level was determined according to the procedures outlined in ISO 11094.

Sound Pressure Level

This unit has a sound pressure level at the operator's ear of 86 dBA, which includes an Uncertainty Value (K) of 1 dBA.

Sound pressure level was determined according to the procedures outlined in EN 836.

Vibration Level

Hand-Arm

Measured vibration level for right hand = 0.27 m/s²

Measured vibration level for left hand = 0.29 m/s²

Uncertainty Value (K) = 0.5 m/s²

Measured values were determined according to the procedures outlined in EN 836.

Whole Body

Measured vibration level = 0.5 m/s²

Uncertainty Value (K) = 0.5 m/s²

Measured values were determined according to the procedures outlined in EN 836.

Safety and Instructional Decals



Safety decals and instructions are easily visible to the operator and are located near any area of potential danger. Replace any decal that is damaged or lost.

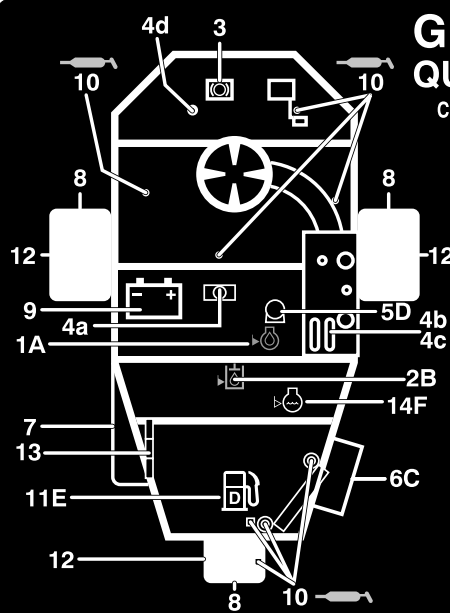

GREENSMASTM 3250-D

QUICK REFERENCE AID

SEE OPERATOR'S MANUAL

CHECK/SERVICE (daily)

1. OIL LEVEL, ENGINE
2. OIL LEVEL, HYDRAULIC TANK
3. BRAKE FUNCTION
4. INTERLOCK SYSTEM:
 - 4a. SEAT INTERLOCK
 - 4b. NEUTRAL SENSOR
 - 4c. MOW SENSOR
 - 4d. PARKING BRAKE INTERLOCK
5. WATER SEPARATOR/FUEL FILTER
6. AIR CLEANER
7. RADIATOR SCREEN
8. TIRE PRESSURE (8-12 psi front, 8-15 psi rear)
9. BATTERY
10. GREASE POINT (8)
11. FUEL - DIESEL #2
12. WHEEL NUT TORQUE (70-90 FT-LBS)
13. FAN/ALTERNATOR/WATER PUMP BELT
14. COOLANT LEVEL

FLUID SPECIFICATIONS / CHANGE INTERVALS

See operator's manual for initial change	FLUID TYPE	CAPACITY		CHANGE INTERVALS		FILTER PART NO.
		L	QT.	FLUID	FILTER	
A. ENGINE OIL	API SJ, SAE 10W-30	3.3	3.5	150 hrs.	150 hrs.	108-3842
B. HYDRAULIC OIL*	MOBIL DTE 15M	20.8	22	800 hrs.	800 hrs.	107-9531
C. AIR CLEANER (CLEAN EVERY 50 HOURS)	—	—	—	—	200 hrs.	108-3811
D. FUEL FILTER	—	—	—	—	800 hrs.	112-9188
E. FUEL TANK	NO. 2 DIESEL	22.7	6.0 GAL.	Drain and flush, 2 years		
F. COOLANT	50/50 ETHYLENE GLYCOL/ WATER MIX	3.4	3.6	Drain and flush, 2 years		

*Including filter

115-3028



93-8068

1. Read the Operator's Manual for instructions on locking and unlocking the steering arm.



93-6686

1. Hydraulic oil
2. Read the Operator's Manual.



93-9051

1. Read the *Operator's Manual*.

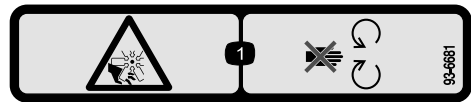

93-6681

1. Cutting/dismemberment—hazard, fan-stay away from moving parts.

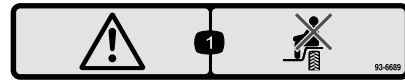

93-6689

1. Warning—do not carry passengers.

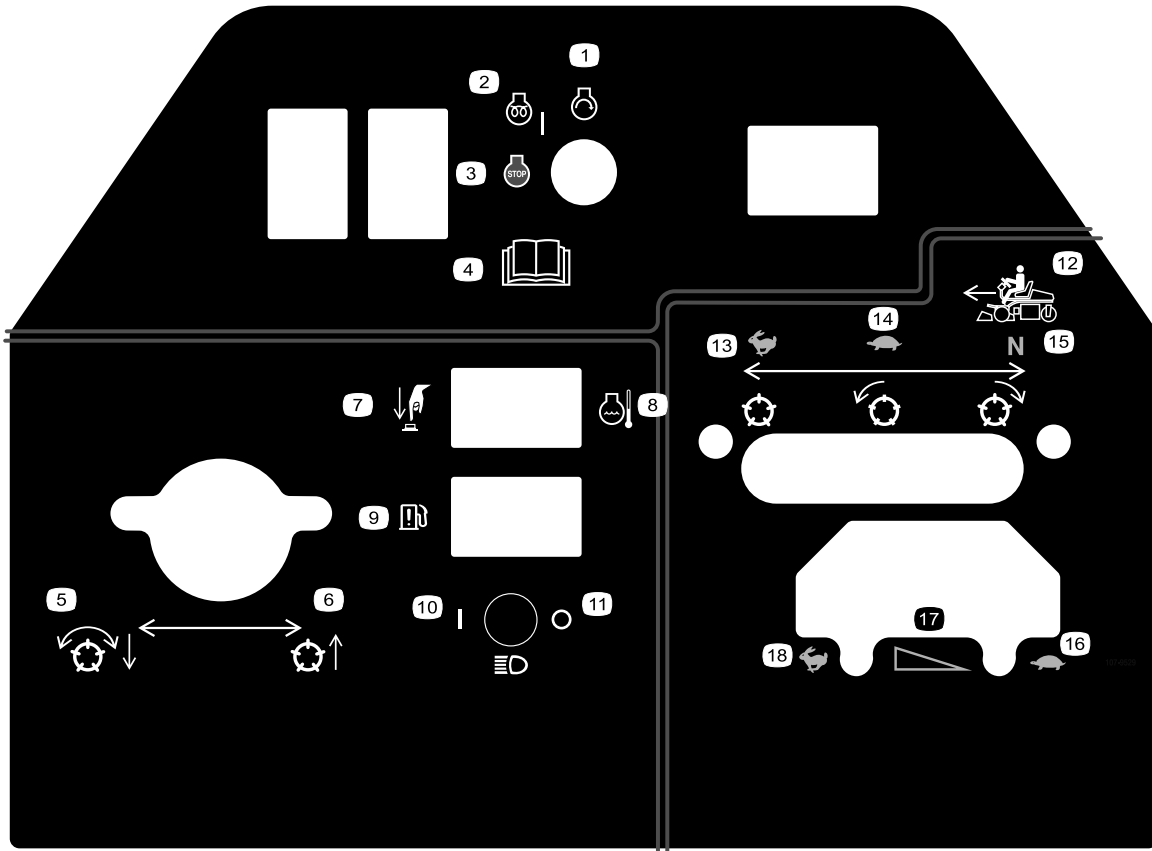

107-9529

- | | | | |
|--|--------------------------------------|---------------------------------------|--|
| 1. Engine start | 6. Raise the reels | 11. Headlights Off | 16. Throttle—slow |
| 2. Engine preheat/on | 7. High temperature override | 12. Functional control lever | 17. Throttle—continuous variable setting |
| 3. Engine stop | 8. Engine coolant temperature | 13. Use for transport | 18. Throttle—fast |
| 4. Read the <i>Operator's Manual</i> . | 9. Water in the fuel indicator light | 14. Use for mowing | |
| 5. Lower the reels and engage. | 10. Headlights On | 15. Neutral—Use for backlapping reels | |

CALIFORNIA SPARK ARRESTER WARNING

Operation of this equipment may create sparks that can start fires around dry vegetation. A spark arrester may be required. The operator should contact local fire agencies for laws or regulations relating to fire prevention requirements. 117-2718

117-2718

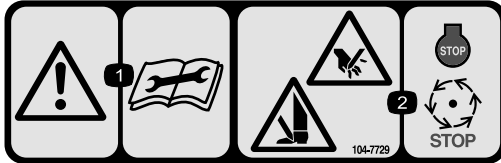

104-7729

1. Warning—read the instructions before servicing or performing maintenance.
2. Cutting/dismemberment hazard; hand or foot—stop the engine and wait for moving parts to stop.

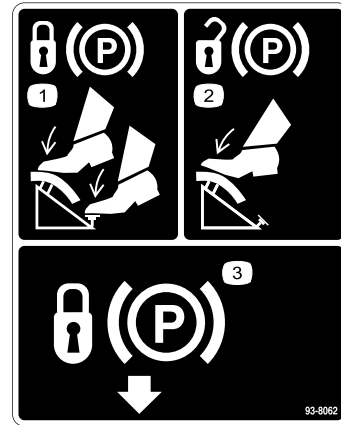

93-8062

1. To lock the parking brake, press the brake pedal and the parking brake lock.
2. To unlock the parking brake, press the brake pedal.
3. Parking brake lock

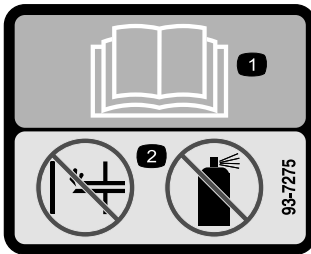

93-7275

(Model 30630 & 30631)

1. Read the *Operator's Manual*.
2. Do not use starting aids.

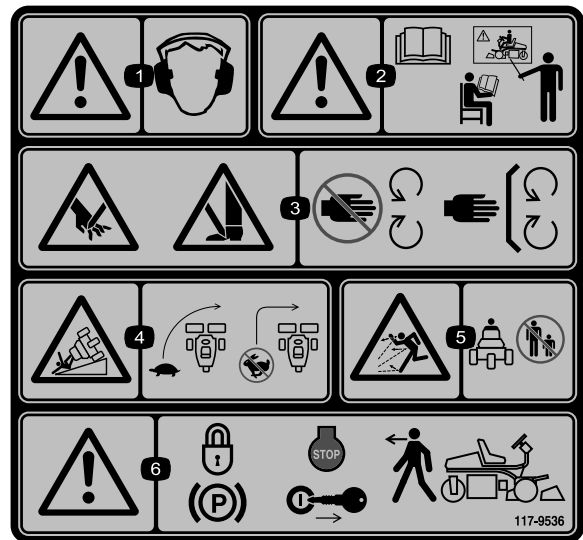

117-9536

1. Warning—wear hearing protection.
2. Warning—read the *Operator's Manual*, do not operate this machine unless you are trained.
3. Cutting/dismemberment hazard of hand or foot, mower blade—stay away from moving parts; keep all guards and shields in place.
4. Tipping hazard—slow machine before turning, do not turn at high speeds.
5. Thrown object hazard—keep bystanders a safe distance from the machine.
6. Warning—lock the parking brake, stop the engine and remove the ignition key before leaving the machine.

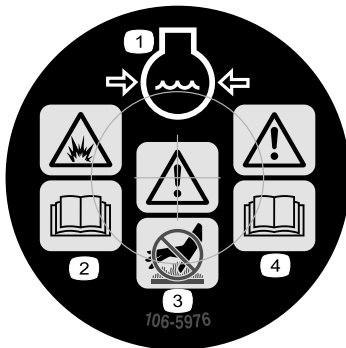

106-5976

1. Engine coolant under pressure
2. Explosion hazard—read the *Operator's Manual*.
3. Warning—do not touch the hot surface.
4. Warning—read the *Operator's Manual*.

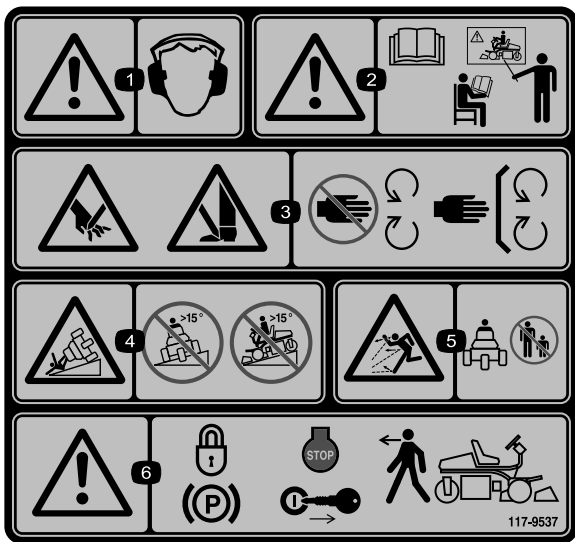

117-9537

Replaces 117-9536 for CE.

* This safety decal includes a slope warning required on the machine for compliance to the European Lawn Mower Safety Standard EN836:1997. The conservative maximum slope angles indication for operation of this machine are prescribed by and required by this standard.

1. Warning—wear hearing protection.
2. Warning—read the *Operator's Manual*, do not operate this machine unless you are trained.
3. Cutting/dismemberment hazard of hand or foot, mower blade—stay away from moving parts; keep all guards and shields in place.
4. Tipping hazard—do not operate machine on slopes greater than 15 degrees.
5. Thrown object hazard—keep bystanders a safe distance from the machine.
6. Warning—lock the parking brake, stop the engine and remove the ignition key before leaving the machine.



Battery Symbols

Some or all of these symbols are on your battery

1. Explosion hazard
2. No fire, open flame, or smoking.
3. Caustic liquid/chemical burn hazard
4. Wear eye protection
5. Read the *Operator's Manual*.
6. Keep bystanders a safe distance from the battery.
7. Wear eye protection; explosive gases can cause blindness and other injuries
8. Battery acid can cause blindness or severe burns.
9. Flush eyes immediately with water and get medical help fast.
10. Contains lead; do not discard.

GREENSMASTER 3XXX							
1	2		3		4		5
	3.8 MPH 6.1 Km/h	5.0 MPH 8.0 Km/h	3.8 MPH 6.1 Km/h	5.0 MPH 8.0 Km/h	3.8 MPH 6.1 Km/h	5.0 MPH 8.0 Km/h	3.8 MPH 6.1 Km/h
0.062" / 1.6mm	N/R	N/R	9	N/R	9	N/R	9
0.094" / 2.4mm	N/R	N/R	9	N/R	9	N/R	9
0.125" / 3.2mm	N/R	N/R	9	N/R	9	N/R	9
0.156" / 4.0mm	N/R	N/R	9	N/R	9	N/R	N/R
0.188" / 4.8mm	N/R	N/R	9	N/R	7	N/R	N/R
0.218" / 5.5mm	N/R	N/R	9	N/R	6	N/R	N/R
0.250" / 6.4mm	7	N/R	6	7	5	7	N/R
0.312" / 7.9mm	6	N/R	5	6	4	6	N/R
0.375" / 9.5mm	6	7	4	5	4	5	N/R
0.438" / 11.1mm	6	6	4	5	3	4	N/R
0.500" / 12.7mm	5	6	3	4	N/R	N/R	N/R
0.625" / 15.9mm	4	5	3	3	N/R	N/R	N/R
0.750" / 19.0mm	3	4	3	3	N/R	N/R	N/R
0.875" / 22.2mm	3	4	N/R	3	N/R	N/R	N/R
1.000" / 25.4mm	3	3	N/R	N/R	N/R	N/R	N/R

115-8156

1. Reel height
2. 5 Blade cutting unit
3. 8 Blade cutting unit
4. 11 Blade cutting unit
5. 14 Blade cutting unit
6. Reel speed
7. Slow
8. Fast

Setup

Loose Parts

Use the chart below to verify that all parts have been shipped.

Procedure	Description	Qty.	Use
1	Wheel hub	1	Install the rear wheel
	Wheel nuts	4	
	Wheel	1	
	Wheel bolt	1	
	Locknut	1	
	Spacers	2	
2	Seat	1	Mount the seat to the base
	Nut (5/16 inch)	4	
3	No parts required	–	Activate and charge the battery.
4	Bolt (1/4 x 5/8 inch)	2	Install the battery.
	Nut (1/4 inch)	2	
5	Anti-scalp roller	2	Mount the front rollers
	Pull link assembly	2	
	Roller shaft	2	
	Spacer	2	
	Washer	4	
	Lock nut, 3/8–16	2	
6	No parts required	–	Adjust the carrier frame rollers
7	No parts required	–	
8	Offset Lift Hook	1	Install the cutting units
	Bolts, M10–1.5	2	
	Gauge bar	1	
	Bolt (#10 x 5/8 inch)	1	
	Jam nut (#10)	1	
	Cutting unit	3	
	Washer	6	
	Ball stud	6	
	Grass Basket	3	
9	No parts required	–	Adjust the transport height
10	Calcium chloride (purchase separately)	40 lb	Add rear ballast
11	Warning decal (117–9537)	1	Install EU decals, if required.
12	Operator's Manual (traction unit)	1	Read the manuals and watch the training materials before operating the machine.
	Engine Operator's Manual (engine)	1	
	Parts Catalog	1	
	Operator Training Materials	1	
	Pre-delivery Inspection Sheet	1	
	Noise rating certificate	1	
	Certificate of compliance	1	
	Ignition keys	2	

Note: Mounting fasteners for the Greensmaster 3250-D cutting units are included with the cutting units.

1

Installing the Rear Wheel

Parts needed for this procedure:

1	Wheel hub
4	Wheel nuts
1	Wheel
1	Wheel bolt
1	Locknut
2	Spacers

Procedure

1. Mount the wheel hub to the rear wheel rim with 4 mounting nuts (Figure 3). Torque the nuts to 70–90 ft.-lb.
2. Remove the wheel bolt and locknut from the wheel mounting holes in the rear castor fork (Figure 3).
3. Install the rear wheel into the castor fork. Insert the wheel bolt into one of the castor fork mounting holes, install a spacer (supplied in loose parts), and slide the bolt through the wheel.
4. Install another spacer onto the bolt and route the bolt through the remaining castor fork mounting hole.
5. Position the bend of the wheel bolt head under the bottom edge of the adapter plate (Figure 3). Install and tighten the locknut to secure the wheel to the castor fork. Do not overtighten the locknut as the wheel must rotate freely.

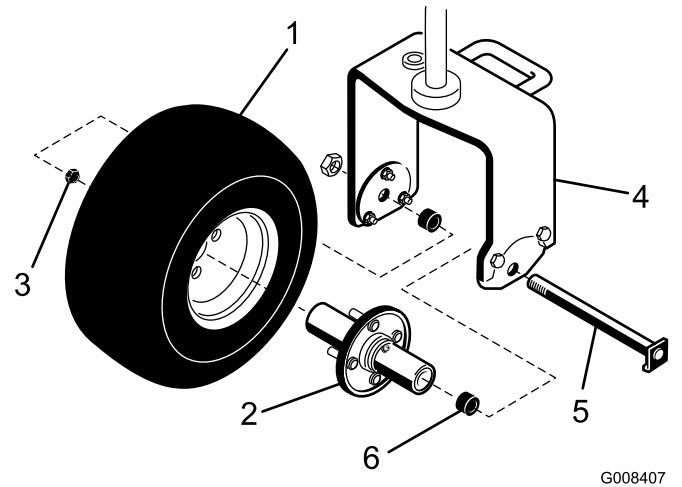

Figure 3

- | | |
|---------------|---------------------|
| 1. Rear wheel | 4. Rear castor fork |
| 2. Hub | 5. Wheel bolt |
| 3. Nut | 6. Spacer (2) |

G008407

6. Wipe the grease fitting clean on the wheel assembly. Pump grease into the wheel hub until grease is seen exiting at both hub bearings. Wipe up excess grease.

2

Mounting the Seat

Parts needed for this procedure:

1	Seat
4	Nut (5/16 inch)

Procedure

Note: Mount the seat slides in the front set of mounting holes to gain an additional 3 in. (7.6 cm) in the forward adjustment, or in the rear mounting holes for an additional 3 in. (7.6 cm) in the rearward adjustment.

1. Remove the locknuts securing the seat slides to the plywood shipping base. Discard the locknuts.
2. Connect the wire harness to the seat switch.
3. Secure the seat, seat panel, and seat slides to the seat support with the locknuts (5/16 in.) (Figure 4) supplied in the loose parts.

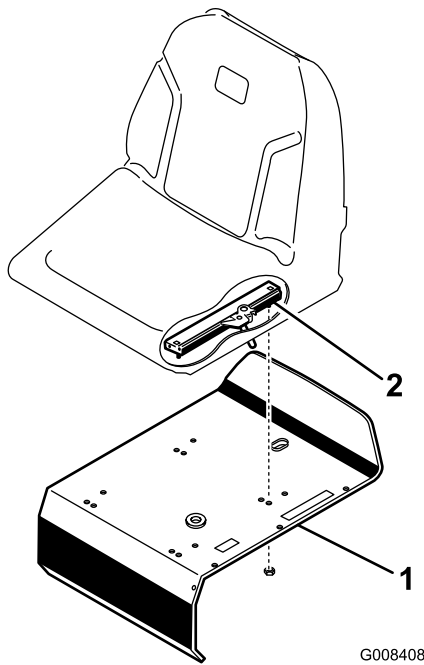

Figure 4

1. Seat support

2. Seat slide

3

Activating and Charging the Battery

No Parts Required

Procedure

Use only electrolyte (1.265 Specific Gravity) to fill battery initially.

1. Remove the wing nuts, washers, and battery clamp and lift out the battery.

Important: Do not add electrolyte while the battery is in the machine. You could spill it, causing corrosion.

2. Clean the top of the battery and remove the vent caps (Figure 5).

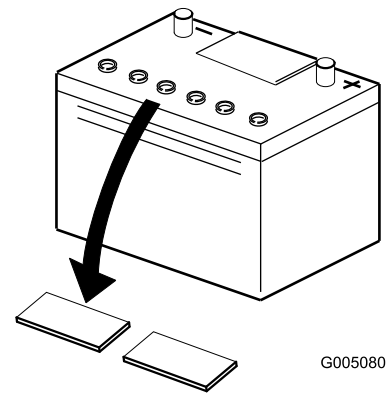

Figure 5

1. Vent caps

3. Carefully fill each cell with electrolyte until the plates are covered with about 1/4 inch (6 mm) of fluid (Figure 6).

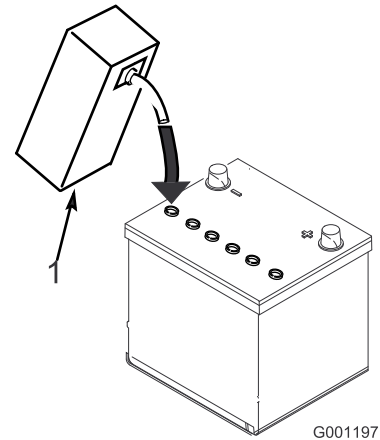

Figure 6

1. Electrolyte

4. Allow approximately 20 to 30 minutes for the electrolyte to soak into the plates. Fill as necessary to bring the electrolyte to within about 1/4 inch (6 mm) of the bottom of the fill well (Figure 6).

⚠ WARNING

Charging the battery produces gasses that can explode.

Never smoke near the battery and keep sparks and flames away from battery.

5. Connect a 2 to 4 amp battery charger to the battery posts. Charge the battery for 2 hours at 4 amps or for 4 hours at 2 amps until the specific gravity is 1.250 or higher and the temperature is at least 60°F (16°C) with all cells gassing freely.
6. When the battery is charged, disconnect the charger from the electrical outlet and battery posts.

Note: After the battery has been activated, add only distilled water to replace normal loss, although maintenance-free batteries should not require water under normal operating conditions.

WARNING

CALIFORNIA Proposition 65 Warning

Battery posts, terminals, and related accessories contain lead and lead compounds, chemicals known to the State of California to cause cancer and reproductive harm.
Wash hands after handling.

⚠ WARNING

Battery terminals or metal tools could short against metal tractor components causing sparks. Sparks can cause the battery gasses to explode, resulting in personal injury.

- When removing or installing the battery, do not allow the battery terminals to touch any metal parts of the tractor.
- Do not allow metal tools to short between the battery terminals and metal parts of the tractor.

⚠ WARNING

Failure to correctly activate the battery may result in battery gassing and/or premature battery failure.

7. First, install the positive cable (red) to the positive (+) terminal and then the negative cable (black) to the negative (-) terminal of the battery and secure them with the bolts and nuts (Figure 7). Slide the rubber boot over the positive terminal to prevent a possible short from occurring.

⚠ WARNING

Incorrect battery cable routing could damage the tractor and cables causing sparks. Sparks can cause the battery gasses to explode, resulting in personal injury.

- Always disconnect the negative (black) battery cable before disconnecting the positive (red) cable.
- Always connect the positive (red) battery cable before connecting the negative (black) cable.

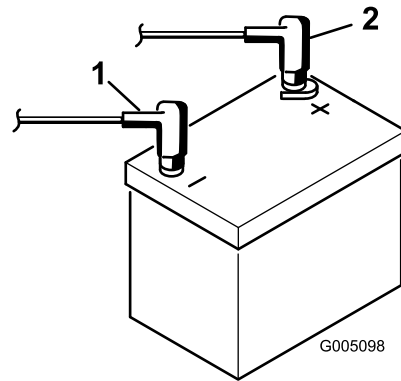

Figure 7

1. Negative (-)
2. Positive (+)

4

Installing the Battery

Parts needed for this procedure:

2	Bolt (1/4 x 5/8 inch)
2	Nut (1/4 inch)

Procedure

1. Mount the battery with the battery terminals toward the hydraulic tank.

WARNING

CALIFORNIA Proposition 65 Warning

Battery posts, terminals, and related accessories contain lead and lead compounds, chemicals known to the State of California to cause cancer and reproductive harm.
Wash hands after handling.

⚠ WARNING

Battery terminals or metal tools could short against metal tractor components causing sparks. Sparks can cause the battery gasses to explode, resulting in personal injury.

- When removing or installing the battery, do not allow the battery terminals to touch any metal parts of the tractor.
 - Do not allow metal tools to short between the battery terminals and metal parts of the tractor.
2. Connect the positive battery cable (red) from the starter solenoid to the positive post (+) of the battery (Figure 8). Secure it with a wrench and coat the terminal with petroleum jelly. Make sure the cable will clear the seat, in the rear-most position, which could cause wear or damage to the cable.

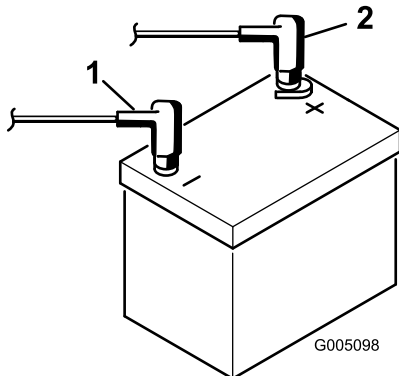

Figure 8

1. Negative (-)
2. Positive (+)

3. Connect the black ground cable to the negative (-) post of the battery. Secure it with a wrench and coat the terminal with petroleum jelly.

⚠ WARNING

Incorrect battery cable routing could damage the tractor and cables causing sparks. Sparks can cause the battery gasses to explode, resulting in personal injury.

- Always disconnect the negative (black) battery cable before disconnecting the positive (red) cable.
 - Always connect the positive (red) battery cable before connecting the negative (black) cable.
4. Place the terminal covers over the battery posts.
 5. Install the battery clamp and covers and secure them with the wing nuts.

5

Mounting the Front Rollers

Parts needed for this procedure:

2	Anti-scalp roller
2	Pull link assembly
2	Roller shaft
2	Spacer
4	Washer
2	Lock nut, 3/8-16

Procedure

1. Mount an anti-scalp roller and a pull link assembly to the outer end of each front carrier frame with a roller shaft, spacer, washers and lock nut (Figure 9). Make sure the components are arranged as shown and the nylon bushings are in the pull link.

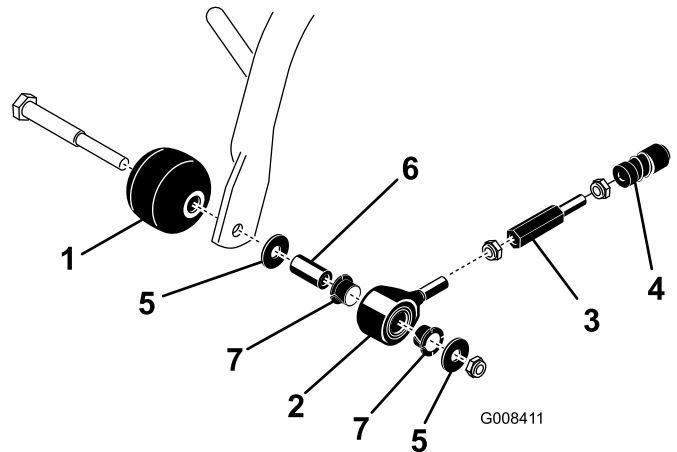

Figure 9

1. Anti-scalp roller
2. Pull link assembly
3. Pull link extension
4. Ball joint receiver
5. Washer (2)
6. Spacer
7. Nylon bushing (2)

2. Make sure all tires are inflated to 8-12 psi.

6

Adjusting the Carrier Frame Rollers

No Parts Required

Procedure

1. Position the machine on a level surface and lower the cutting unit carrier frames to the floor.
2. Verify that there is 1/2 in. (13 mm) clearance between the carrier frame rollers and the floor.
3. If an adjustment is required, loosen the jam nut on the carrier frame stop screw (Figure 10) and rotate the screw up or down to raise or lower the carrier frame. Tighten the jam nut after adjustment is attained.

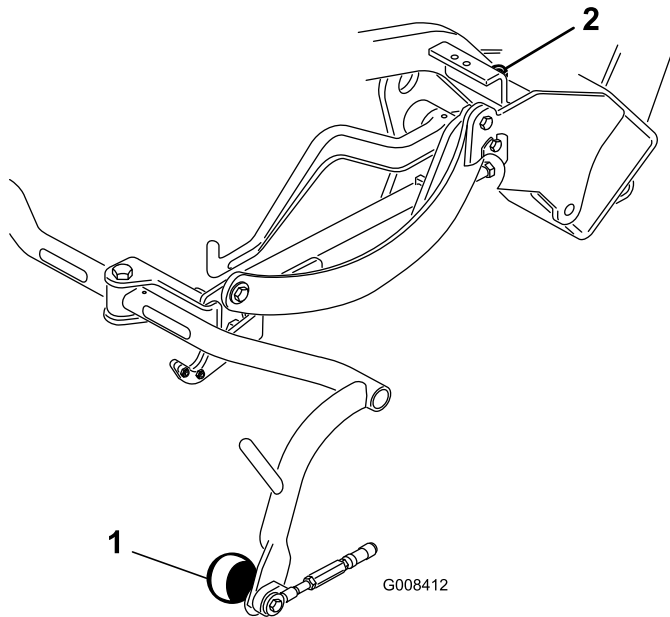

Figure 10

1. Carrier frame roller 2. Carrier frame stop screw

7

Optional Oil Cooler

No Parts Required

Procedure

If you are operating the machine in hot climates, where ambient temperatures range from 70 degrees F (20 degrees C)

to 120 degrees F (49 degrees C), or using it for heavy-duty use (mowing other than greens, such as fairways or verticutting), install a Hydraulic Oil Cooler Kit, Part No. 104-7701, to the machine.

8

Installing the Cutting Units (For Cutting Unit Models 04610, 04611 and 04616 Only)

Parts needed for this procedure:

1	Offset Lift Hook
2	Bolts, M10-1.5
1	Gauge bar
1	Bolt (#10 x 5/8 inch)
1	Jam nut (#10)
3	Cutting unit
6	Washer
6	Ball stud
3	Grass Basket

Procedure

Note: When sharpening, setting the height-of-cut or performing other maintenance procedures on the cutting units, store the cutting unit reel motors in the support tubes to prevent damage to the hoses.

Important: Do not raise the suspension to the transport position when the reel motors are in the holders in the machine frame. Damage to the motors or hoses could result

Important: Whenever the cutting unit has to be tipped to expose bedknife/reel, prop up rear of cutting unit to make sure nuts on back end of bedbar adjusting screws are not resting on work surface (Figure 11).

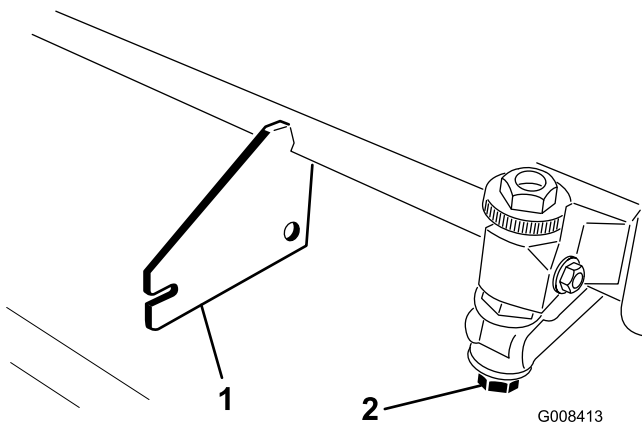

Figure 11

1. Prop (not provided)
2. Bedknife adjusting screw nut (2)

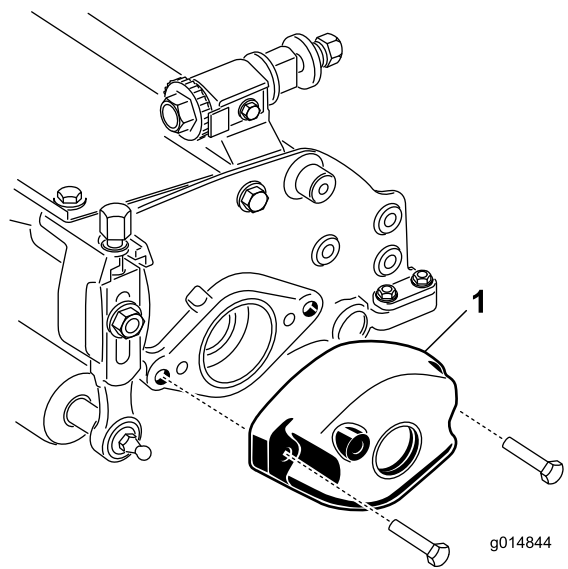

Figure 13

1. Counter weight

1. Remove the cutting units from the cartons. Assemble and adjust them as listed in the cutting unit *Operator's Manual*. Use the gauge bar from the loose parts kit to adjust the height of cut.
2. Install the offset lift hook (Figure 12) to the top of the cutting unit with (2) M10–1.5 bolts. Torque the bolts to 25–30 ft–lbs. (34–40 N·m). The offset lift hook should be positioned with hook forward.

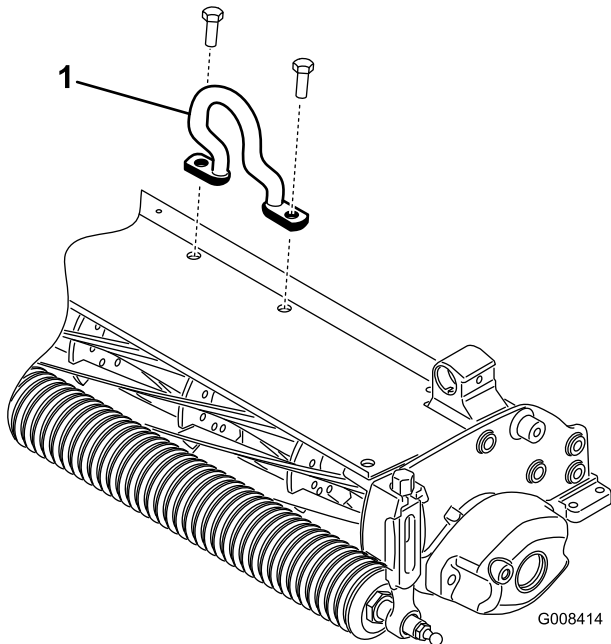

Figure 12

1. Offset lift hook

- B. On right end of cutting unit, remove plastic plug from bearing housing (Figure 14).
- Note:** Retain the protective covers for the cutting units. Install them whenever the reel drive motors are removed to protect the cutting unit bearings from contamination.
- C. Remove the 2 allen head screws securing the motor mount to the right end of the cutting unit. Remove the motor mount (Figure 14).

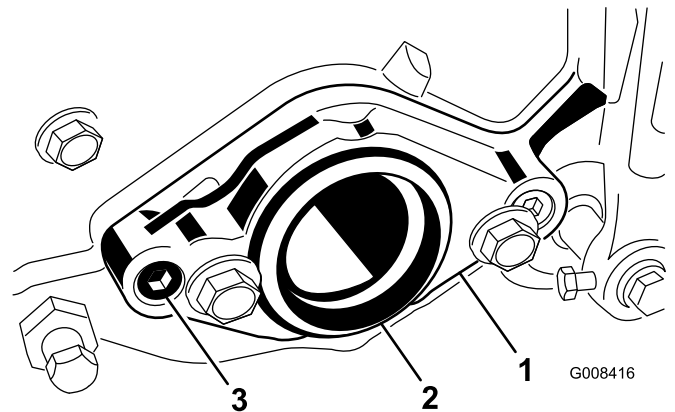

Figure 14

1. Motor mount
2. Plastic plug
3. Allen head screw (2)

3. All cutting units are shipped with the counter weight mounted to the left end and the motor mount and drive coupler mounted to the right end of the cutting unit. To mount the cutting unit in the right front position, proceed as follows:
 - A. Remove the 2 bolts securing the counter weight to the left end of the cutting unit. Remove the counter weight (Figure 13).

- D. Remove the snap ring securing the drive coupler in the reel tube (Figure 15). Remove the drive coupler.

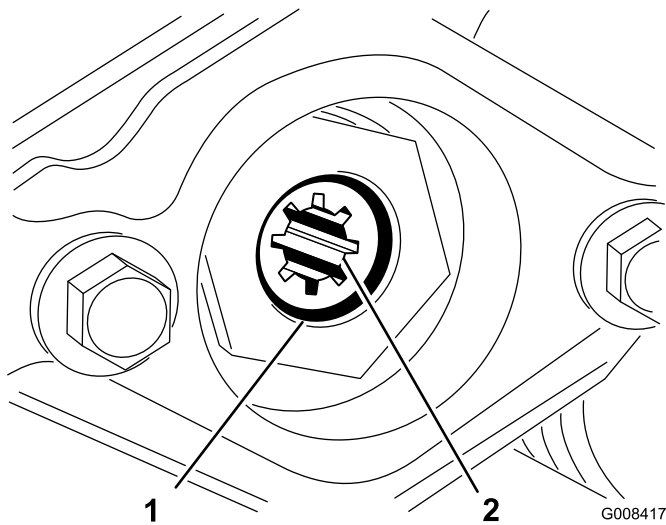

Figure 15

1. Snap ring 2. Drive coupler

- E. Apply grease to the inside diameter of the drive coupler. Install the drive coupler to the left end of the cutting unit reel tube with a snap ring.
- F. Install the motor mount to the left end of the cutting unit with the (2) allen head screws previously removed. Torque screws to 12–15 ft–lbs. (16–20 N·m).
- G. Install the counter weight to the right end of the cutting unit with the screws previously removed.

4. The cutting unit is shipped without a front roller. Obtain a roller (Model No. 04625, 04626 or 04627) from your local Toro Distributor. Install the roller using the loose parts supplied with the cutting unit and installation instructions included with the roller.
5. Thread a ball stud into each end of the cutting unit front roller (Figure 16).

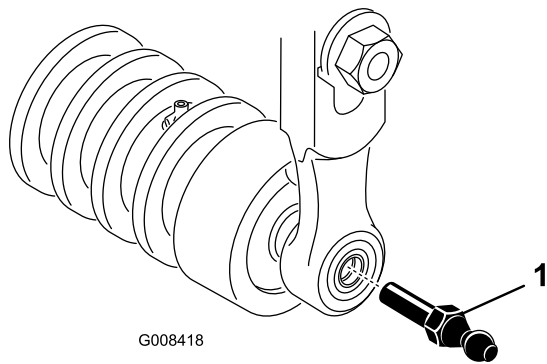

Figure 16

1. Ball stud

6. Slide the cutting unit under the pull frame while hooking the lift hoop onto the lift arm.
7. Slide the sleeve back on each ball joint receiver and hook the receiver onto the cutting unit ball stud (Figure 17).

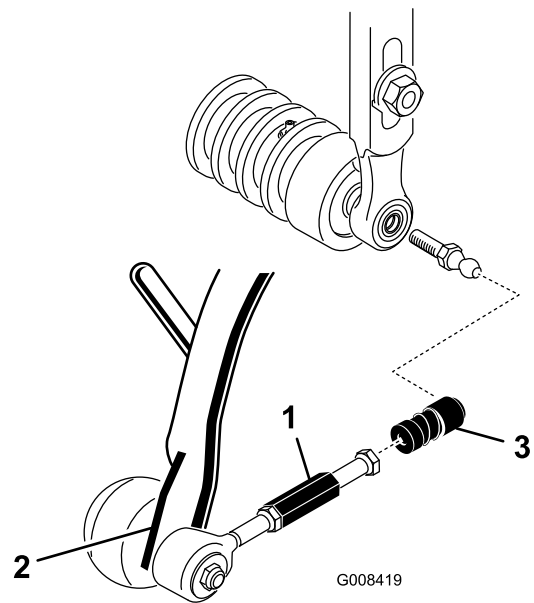

Figure 17

1. Pull link extension 3. Ball joint receiver
2. Pull arm

8. Mount the basket onto the carrier frame.
9. Adjust the pull links until there is 1/16 to 1/8 in. (2 to 3 mm) clearance between the lip of the basket and the reel blades. Make sure the basket lips are equidistant from the reel blades all the way across the reel blades.
10. Assemble the mounting screws for the reel drive motor to each cutting unit. Leave approximately 1/2 in. (13 mm) of the threads exposed on each mounting screw (Figure 18).

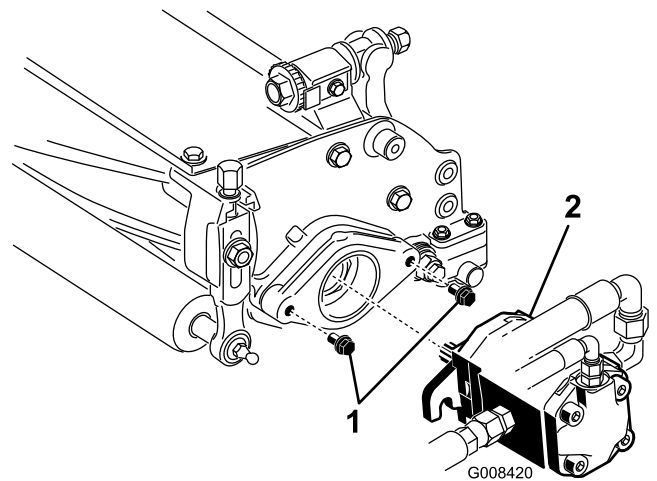

Figure 18

1. Screws 2. Drive motor

11. Using a hand pump grease gun, fill the cavity at the end of the cutting unit with #2 general purpose grease.
12. Coat the spline shaft of the motor with clean grease and install the motor by rotating the motor clockwise so the motor flanges clear the studs. Rotate the motor

counterclockwise until the flanges are encircling the studs (Figure 18).

13. Tighten the mounting bolts (Figure 18).

9

Adjusting the Transport Height

No Parts Required

Procedure

Check the transport height (Figure 19 & Figure 20) and adjust, if required.

1. Position the tractor on a level surface.
2. On cutting units equipped with a chain link or a straight lift hook (Figure 19 & Figure 20, insets) verify that the distance from the top of the carrier frame adjusting screw to the back of the carrier frame is 7/8 inch (22 mm). If the distance is not 7/8 inch (22 mm), proceed to step 4. If the cutting unit is equipped with an offset lift link (Figure 21), proceed to the next step.

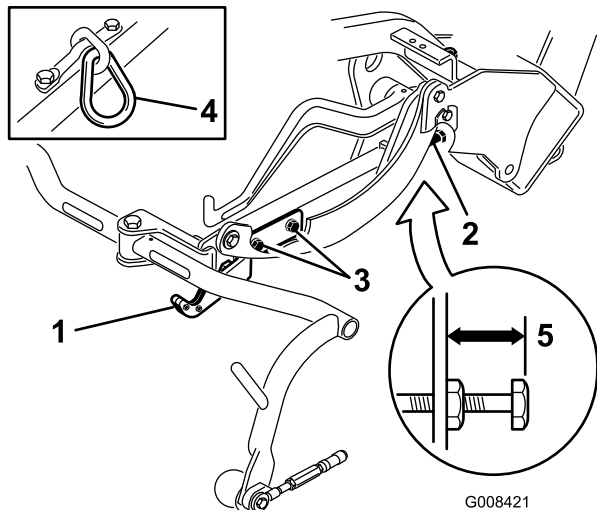

Figure 19

- | | |
|-----------------------------------|---------------------|
| 1. Transport plate | 4. Chain link |
| 2. Adjusting screw | 5. 7/8 inch (22 mm) |
| 3. Transport plate mounting screw | |

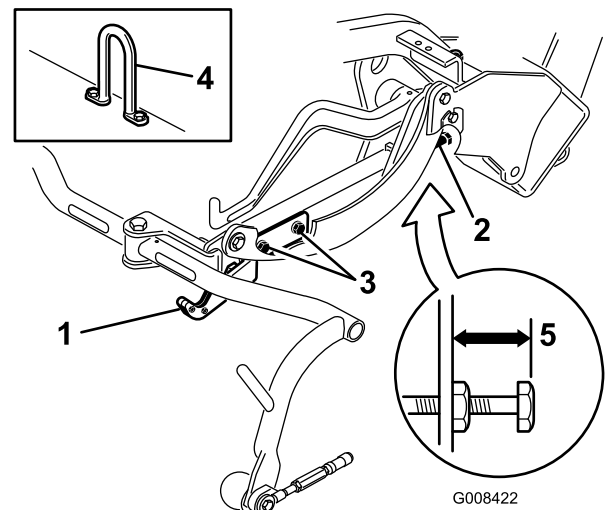

Figure 20

- | | |
|-----------------------------------|---------------------|
| 1. Transport plate | 4. Link hook |
| 2. Adjusting screw | 5. 7/8 inch (22 mm) |
| 3. Transport plate mounting screw | |

3. On cutting units equipped with an offset lift hook (Figure 21, inset) verify that the distance from the top of the carrier frame adjusting screw to the back of the carrier frame is 1 inch (25 mm). If the distance is not 1 inch (22 mm), proceed to step 4.

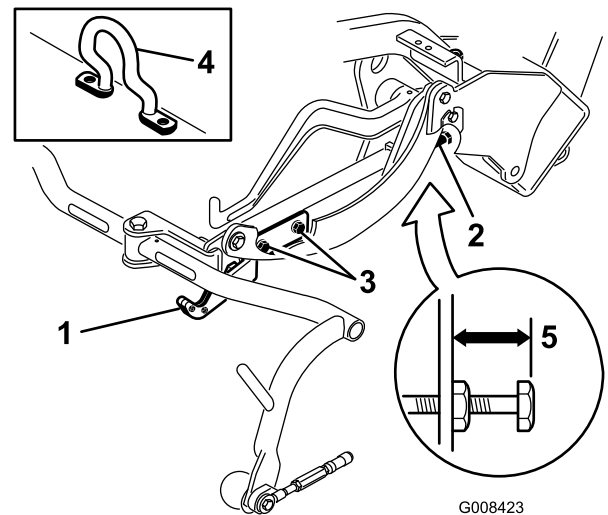

Figure 21

- | | |
|-----------------------------------|---------------------|
| 1. Transport plate | 4. Offset lift hook |
| 2. Adjusting screw | 5. 1 inch (25 mm) |
| 3. Transport plate mounting screw | |

4. Loosen the transport plate mounting screws (Figure 19, Figure 20 and Figure 21).
5. Raise the cutting units to the transport position.

Important: Do not raise the suspension to the transport position when the reel motors are in the

holders in the machine frame. Damage to the motors or hoses could result.

6. Ensure each carrier frame is at the same height from the ground. If they are, proceed to step 8.
7. If the carrier frames are not at the same height, loosen the jam nut on the carrier frame adjusting screw (Figure 19, Figure 20 and Figure 21). Rotate the screw outward to raise and inward to lower. Tighten the jam nut after the proper height is obtained.
8. Rotate the transport plate until it locks the pull frame. Tighten the screws.

12

Reading the Manuals and Viewing the Training Materials

Parts needed for this procedure:

1	<i>Operator's Manual</i> (traction unit)
1	<i>Engine Operator's Manual</i> (engine)
1	<i>Parts Catalog</i>
1	Operator Training Materials
1	Pre-delivery Inspection Sheet
1	Noise rating certificate
1	Certificate of compliance
2	Ignition keys

Procedure

1. Read the manuals.
2. View the Operator Training Materials.
3. Store the documentation in a safe place.

10

Adding Rear Ballast

Parts needed for this procedure:

40 lb	Calcium chloride (purchase separately)
-------	--

Procedure

This unit complies with the ANSI B71.4-2004 and EN 836 Standards when 40 lb of calcium chloride ballast is added to the rear wheel.

Important: If a puncture occurs in a tire with calcium chloride, remove the unit from the turf area as quickly as possible. To prevent possible damage to the turf, immediately soak the affected area with water.

11

Install EU Decals

Parts needed for this procedure:

1	Warning decal (117-9537)
---	--------------------------

Procedure

If this machine will be used in the EU, affix the warning decal 117-9537 over English warning decal (117-9536).

Product Overview

Controls

Traction and Stopping Pedal

The traction pedal (Figure 22) has three functions: to make the machine move forward, to move it backward, and to stop the machine. Press the top of the pedal to move forward and the bottom of the pedal to move backward or to assist in stopping when moving forward. Also, allow the pedal to move to the neutral position to stop the machine. For operator comfort, do not rest the heel of your foot on reverse when operating forward (Figure 23).

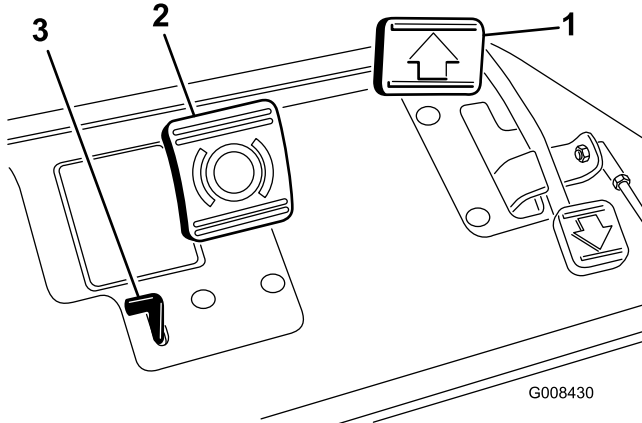

Figure 22

1. Traction pedal
2. Brake pedal
3. Parking brake lever



Figure 23

Brake Pedal

The brake pedal (Figure 22) actuates an automotive drum-type mechanical brake at each traction wheel.

Parking Brake Lever

Pressing the brake pedal to actuate the brake assembly, then pressing the small lever indicated (Figure 22) will keep the

brakes actuated for parking. Disengage it by pressing the brake pedal. Form the habit of locking the parking brake before you leave the machine. Lock the parking brake any time you leave the machine.

Throttle Control

The throttle control (Figure 24) gives the operator the ability to control the speed of the engine. Moving the throttle control toward the Fast position increases the engine RPM; moving the throttle control toward Slow will decrease the engine RPM. Ground speeds are as follows:

- 2 to 5 MPH (3.2 to 8 km/h) forward mowing speed
- 8.8 MPH (14.1 km/h) maximum transport speed
- 2.5 MPH (4.0 km/h) reverse speed

Note: The engine cannot be stopped by the use of the throttle control.

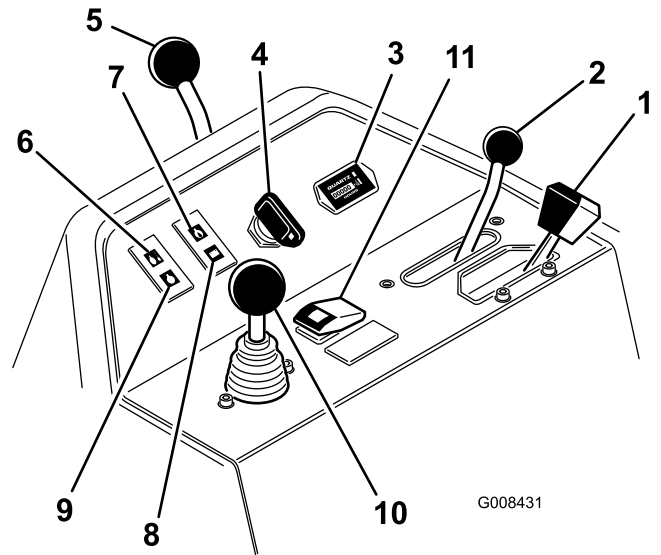

Figure 24

1. Throttle control
2. Functional control lever
3. Hour meter
4. Ignition switch
5. Steering arm locking lever
6. Water temperature light
7. Engine oil pressure light
8. Battery warning light
9. Glow plug indicator light
10. Raise/Lower Mow Control
11. High temperature override button

Functional Control Lever

The functional control lever (Figure 24) provides two traction selections plus a Neutral position. It is permissible to shift from mow to transport or transport to mow (not to neutral) while the machine is in motion. No damage will result.

- Rear Position—neutral and backlapping
- Middle Position—used for mowing operation
- Front Position—used for transport operation

Hour Meter

The hour meter (Figure 24) indicates the total hours the machine has operated. It starts to function whenever the key switch is rotated to On.

Ignition Switch

Insert the key into the switch (Figure 24) and turn it clockwise as far as possible to the Start position to start the engine. Release the key as soon as the engine starts; the key will move to the On position. Turn the key counterclockwise to the Off position to stop the engine.

Steering Arm Locking Lever

Rotate the lever (Figure 24) rearward to loosen the adjustment, raise or lower the steering arm for operator comfort, then, rotate the lever forward to tighten the adjustment.

Water Temperature Light

The light (Figure 24) glows and the engine automatically shuts down when the engine coolant temperature gets too high.

Engine Oil Pressure Light

The light (Figure 24) glows if the engine oil pressure drops below a safe level.

Battery Warning Light

The light (Figure 24) glows if the battery charge is low.

Glow Plug Indicator Light

When the glow plug indicator light (Figure 24) is lit, it indicates the glow plugs are on.

Note: The glow plug indicator light may illuminate for a short time after the engine has started; this is normal.

Raise/Lower Mow Control

Moving the control (Figure 24) forward during operation lowers the cutting units and starts the reels. Pull back on the control to stop the reels and raise the cutting units. During operation the reels can be stopped by pulling back on the control momentarily and releasing it. Restart the reels by moving the control forward.

High Temperature Override Button

If the engine kills due to an overheating condition, press the override button (Figure 24) in and hold it until the machine can be moved to a safe location and allowed to cool down.

Note: When using the override button, it must be held down continuously to operate. Do not use it for extended periods of time.

Backlap Lever

Use the backlap lever (Figure 25) in conjunction with the raise/lower mow control lever and the reel speed control for backlapping the reels.

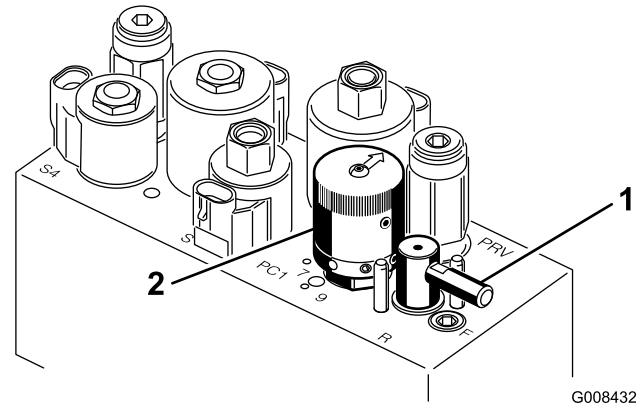

Figure 25

G008432

1. Backup lever

2. Reel speed control

Reel Speed Control

Use the reel speed control (Figure 25) to adjust the RPM of the reels.

Seat Adjusting Lever

The seat adjusting lever on the left side of the seat (Figure 26) allows a 7 in. (18 cm) fore and aft adjustment.

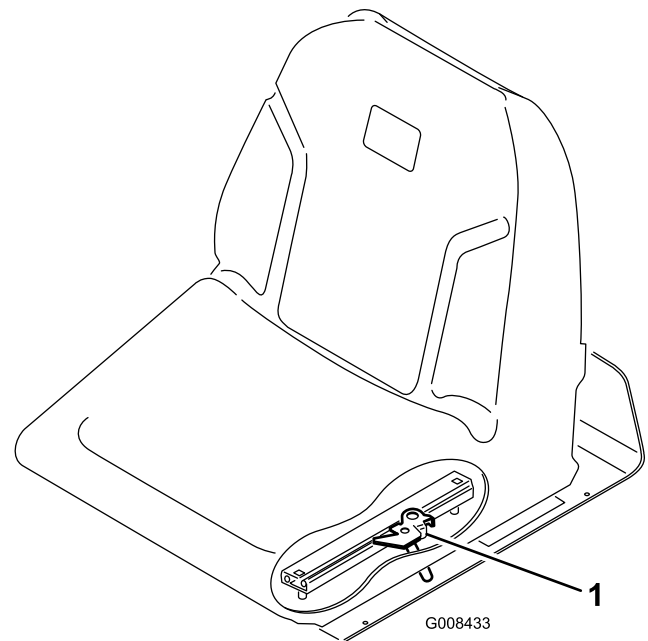

Figure 26

G008433

1. Seat adjusting handle

Fuel Shut-Off Valve

Close the fuel shut-off valve (Figure 27), under the fuel tank, when storing or transporting the machine on a truck or trailer.

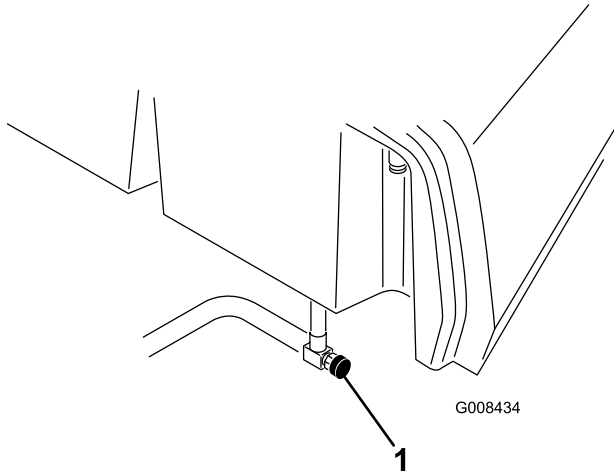

Figure 27

1. Fuel shut-off (under the fuel tank)

Specifications

Note: Specifications and design are subject to change without notice.

Width of cut	59 inches (150 cm)
Wheel tread	50.5 inches (128 cm)
Wheel base	48.6 inches (123 cm)
Overall length (w/baskets)	93.9 inches (238 cm)
Overall width	68 inches (173 cm)
Overall height	50.5 inches (128 cm)
Net Weight w/reels (8 Blade 4 Bolt)	1338 lb (608 kg)

Attachments/Accessories

A selection of Toro approved attachments and accessories are available for use with the machine to enhance and expand its capabilities. Contact your Authorized Service Dealer or Distributor or go to www.Toro.com for a list of all approved attachments and accessories.

Operation

Note: Determine the left and right sides of the machine from the normal operating position.

Think Safety First

Please carefully read all of the safety instructions and symbols in the safety section. Knowing this information could help you or bystanders avoid injury.

The use of protective equipment, such as but not limited to, for eyes, ears, feet, and head is recommended.

⚠ CAUTION

This machine produces sound levels in excess of 85dBA at the operator's ear and can cause hearing loss through extended periods of exposure.

Wear hearing protection when operating this machine.

Checking the Engine Oil

The engine is shipped with oil in the crankcase; however, the oil level must be checked before and after the engine is first started.

Crankcase capacity is approximately 3.5 quarts (3.3 l) with the filter.

Use high-quality engine oil that meets the following specifications:

- API Classification Level Required: CH-4, CI-4 or higher.
- Preferred oil: SAE 10W-30 Alternate oil: SAE 5W-30
- Alternate oil: SAE 5W-30

Toro Premium Engine oil is available from your distributor in the 10W-30 viscosity. See the parts catalog for part numbers.

Note: The best time to check the engine oil is when the engine is cool before it has been started for the day. If it has already been run, allow the oil to drain back down to the sump for at least 10 minutes before checking. If the oil level is at or below the "add" mark on the dipstick, add oil to bring the oil level to the "full" mark. **DO NOT OVERFILL.** If the oil level is between the "full" and "add" marks, no oil addition is required.

Important: Be sure to keep the engine oil level between the upper and lower limits on the oil gauge. Engine failure may occur as a result of over filling or under filling the engine oil.

1. Position the machine on a level surface.
2. Remove the dipstick and wipe it with a clean rag (Figure 29). Push the dipstick into the tube and make sure it is seated fully. Remove the dipstick from the tube and check the level of oil. If the oil level is low, remove the filler cap from the valve cover and slowly add enough

oil to raise the level to the Full mark on the dipstick. Add the oil slowly and check the level often during this process. **Do not overfill.**

Important: Make sure that the dipstick is removed while filling the engine with oil. When adding engine oil or filling oil, there *must be* clearance between the oil fill device and the oil fill hole in the valve cover as shown in Figure 28. This clearance is necessary to permit venting when filling, which prevents oil from overrunning into breather.

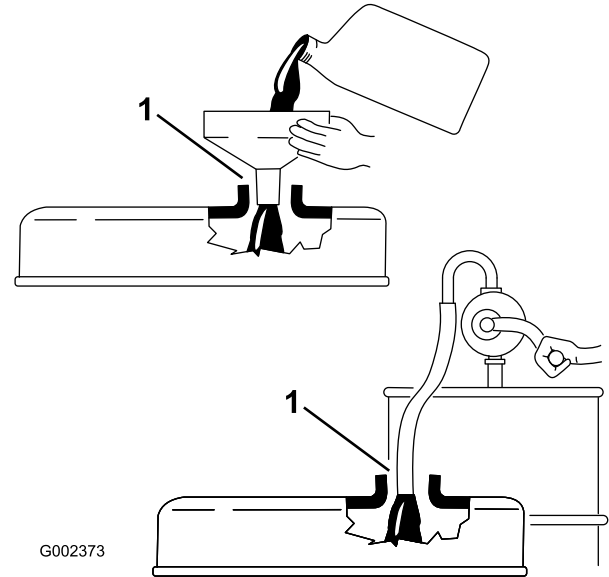

Figure 28

1. Note clearance

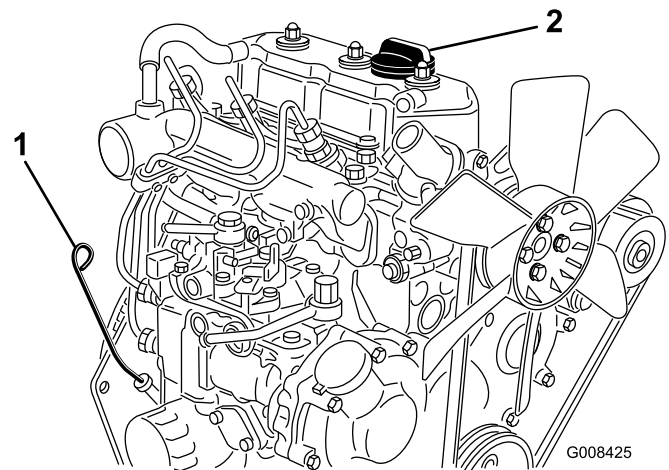

Figure 29

1. Dipstick
2. Filler cap

3. Replace the dipstick.
4. Start and run the engine at idle for 30 seconds, then shut the engine off. Wait 30 seconds, then repeat steps 2-3.

Important: Check the level of oil every 8 operating hours or daily. Change the oil and filter initially

after the first 50 hours of operation, thereafter change the oil and the filter every 150 hours. However, change the oil more frequently when the engine is operated in extremely dusty or dirty conditions.

5. Install the filler cap and dipstick firmly in place.

Filling the Fuel Tank

Use only clean, fresh diesel fuel or biodiesel fuels with low (<500 ppm) or ultra low (<15 ppm) sulfur content. The minimum cetane rating should be 40. Purchase fuel in quantities that can be used within 180 days to ensure fuel freshness.

Fuel tank capacity: 6 U.S. gallons (22.7 l)

Use summer grade diesel fuel (No. 2-D) at temperatures above 20 degrees F (-7 degrees C) and winter grade (No. 1-D or No. 1-D/2-D blend) below that temperature. Use of winter grade fuel at lower temperatures provides lower flash point and cold flow characteristics which will ease starting and reduce fuel filter plugging.

Use of summer grade fuel above 20 degrees F (-7 degrees C) will contribute toward longer fuel pump life and increased power compared to winter grade fuel.

⚠ DANGER

Under certain conditions, diesel fuel and fuel vapors are highly flammable and explosive. A fire or explosion from fuel can burn you and others and can cause property damage.

- Use a funnel and fill the fuel tank outdoors, in an open area, when the engine is off and is cold. Wipe up any fuel that spills.
- Do not fill the fuel tank completely full. Add fuel to the fuel tank until the level is 1/4 to 1/2 in. (6 to 13 mm) below the bottom of the filler neck. This empty space in the tank allows the fuel to expand.
- Never smoke when handling fuel, and stay away from an open flame or where fuel fumes may be ignited by a spark.
- Store fuel in a clean, sealed, safety-approved container.

Biodiesel Ready

This machine can also use a biodiesel blended fuel of up to B20 (20% biodiesel, 80% petrodiesel). The petrodiesel portion should be low or ultra low sulfur. Observe the following precautions:

- The biodiesel portion of the fuel must meet specification ASTM D6751 or EN14214.

- The blended fuel composition should meet ASTM D975 or EN590.
- Painted surfaces may be damaged by biodiesel blends.
- Use B5 (biodiesel content of 5%) or lesser blends in cold weather
- Monitor seals, hoses, gaskets in contact with fuel as they may be degraded over time.
- Fuel filter plugging may be expected for a time after converting to biodiesel blends.
- Contact your distributor if you wish for more information on biodiesel

⚠ DANGER

In certain conditions, fuel is extremely flammable and highly explosive. A fire or explosion from fuel can burn you and others and can damage property.

- **Fill the fuel tank outdoors, in an open area, when the engine is cold. Wipe up any fuel that spills.**
- **Do not fill the fuel tank completely full. Add fuel to the fuel tank until the level is 1 in. (25 mm) below the bottom of the filler neck. This empty space in the tank allows fuel to expand.**
- **Never smoke when handling fuel, and stay away from an open flame or where fuel fumes may be ignited by a spark.**
- **Store fuel in an approved container and keep it out of the reach of children. Never buy more than a 30-day supply of fuel.**
- **Always place fuel containers on the ground away from your vehicle before filling**
- **Do not fill fuel containers inside a vehicle or on a truck or trailer bed because interior carpets or plastic truck bed liners may insulate the container and slow the loss of any static charge.**
- **When practical, remove gas-powered equipment from the truck or trailer and refuel the equipment with its wheels on the ground.**
- **If this is not possible, then refuel such equipment on a truck or trailer from a portable container, rather than from a fuel dispenser nozzle.**
- **If a fuel dispenser nozzle must be used, keep the nozzle in contact with the rim of the fuel tank or container opening at all times until fueling is complete.**

1. Clean around the fuel tank cap (Figure 30).

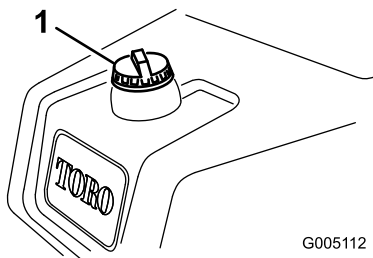

Figure 30

1. Fuel tank cap

2. Remove the fuel tank cap.
3. Fill the tank until the level is 1/4 to 1/2 in. (6 to 13 mm) below the bottom of the filler neck. **Do not overfill.** Install the cap.
4. Wipe up any fuel that may have spilled.

Checking the Cooling System

The capacity of the cooling system is approximately 3.6 qts. (3.4 l). Refer to Cleaning the Radiator and Screen.

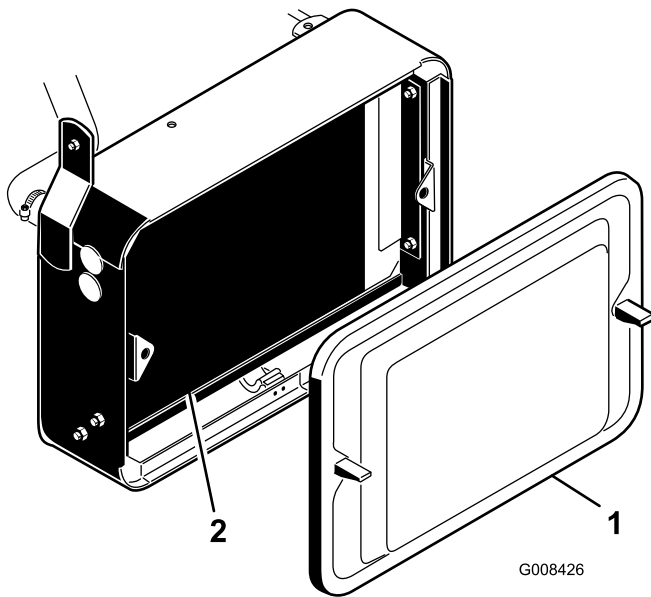

Figure 31

1. Radiator screen
2. Radiator

The cooling system is filled with a 50/50 solution of water and permanent ethylene glycol antifreeze. Check the level of the coolant at the beginning of each day before starting the engine.

CAUTION

If the engine has been running, the pressurized, hot coolant can escape and cause burns.

- Do not open the radiator cap when the engine is running.
- Use a rag when opening the radiator cap, and open the cap slowly to allow steam to escape.

1. Park the machine on a level surface.
2. Check the coolant level (Figure 32). It should be between the lines on the reserve tank when the engine is cold.

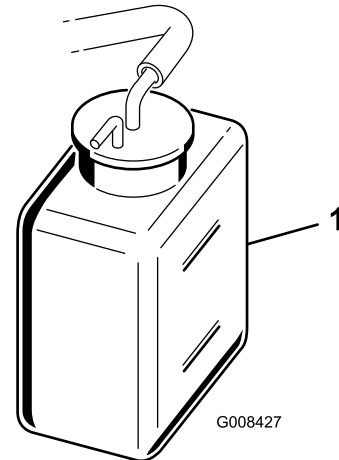

Figure 32

1. Reserve tank

3. If the coolant is low, remove the reserve tank cap and add a 50/50 mixture of water and permanent ethylene glycol antifreeze. **Do not overfill.**
4. Install the reserve tank cap.

Checking the Hydraulic Fluid Level

Recommended Hydraulic Fluid

The machine's reservoir is filled at the factory with approximately 5.5 gallons (20.8 l) of high quality hydraulic fluid. **Check the level of the hydraulic fluid before the engine is first started and daily thereafter.** The recommended replacement fluid is as follows:

Toro Premium All Season Hydraulic Fluid (Available in 5 gallon pails or 55 gallon drums. See parts catalog or Toro distributor for part numbers.)

Alternate fluids: If the Toro fluid is not available, other fluids may be used provided they meet all the following material properties and industry specifications. We do not recommend the use of synthetic fluid. Consult with your lubricant distributor to identify a satisfactory product

- If the fluid level is low, slowly fill the reservoir with the appropriate hydraulic fluid until the level reaches the bottom of the screen. **Do not overfill.**

Important: To prevent system contamination, clean the top of the hydraulic fluid containers before puncturing. Ensure the pour spout and funnel are clean.

- Install the reservoir cap. Wipe up any fluid that may have spilled.

Important: Check level of hydraulic fluid before engine is first started and daily thereafter.

Draining Water from the Fuel Filter

Any water accumulation should be drained from the fuel filter before each use.

- Position the machine on a level surface and stop the engine.
- Place a drain pan under the fuel filter.
- Open the drain plug on the fuel filter approximately one turn and drain any accumulated water (Fig. 26). Tighten the plug after draining.

Note: Because the accumulated water will be mixed with diesel fuel, drain the fuel filter into a suitable container and dispose of it properly.

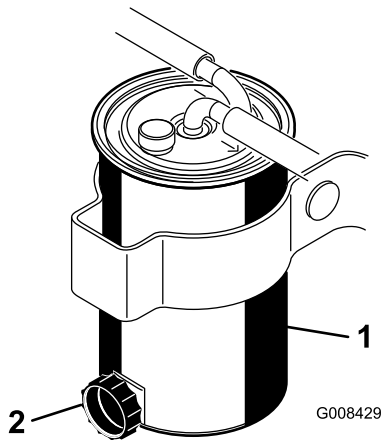

Figure 34

1. Fuel filter

2. Drain plug

Checking the Tire Pressure

The tires are over-inflated at the factory for shipping purposes. Reduce the pressure to the proper levels before starting the unit.

Vary the tire pressure for the front wheels, depending upon your turf conditions, from a minimum of 8 psi to a maximum of 12 psi (55 to 83 kPa).

Vary the tire pressure for the rear wheel from a minimum of 8 psi to a maximum of 15 psi (55 to 103 kPa).

Checking the Reel-to-Bedknife Contact

Each day before operating the machine, check the reel-to-bedknife contact, regardless if the quality of cut had previously been acceptable. There must be light contact across the full length of the reel and bedknife; refer to Adjusting the Reel to Bedknife in the Cutting Unit Operator's Manual.

Checking the Torque of the Wheel Nuts

▲ WARNING

Failure to maintain proper torque of the wheel nuts could result in personal injury.

Torque the wheel nuts to 70-90 ft-lb after 1-4 hours of operation and again after 10 hours of operation. Torque every 200 hours thereafter.

Break-in Period

Refer to the Engine Manual supplied with the machine for oil change and maintenance procedures recommended during the break-in period.

Only 8 hours of mowing operation is required for the break-in period.

Since the first hours of operation are critical to future dependability of the machine, monitor its functions and performance closely so that minor difficulties, which could lead to major problems, are noted and can be corrected. Inspect the machine frequently during break-in for signs of oil leakage, loose fasteners, or any other malfunction.

To ensure optimum performance of the brake system, burnish (break-in) the brakes before using the machine. To burnish the brakes, firmly apply the brakes and drive the machine at mowing speed until the brakes are hot, as indicated by their smell. An adjustment to the brakes may be required after break-in; refer to Adjusting the Brakes.

Starting and Stopping the Machine

Note: Inspect the areas beneath the mowers to be certain they are clear of debris.

Starting

Important: the fuel system may have to be bled if any of the following situations have occurred:

- Initial start up of a new engine
- The engine has ceased running due to lack of fuel.
- Maintenance has been performed upon fuel system components; ie. filter replaced, etc.

Refer to Bleeding the Fuel System.

Important: Do not use ether or other types of starting fluid.

1. Be sure the parking brake is set, the raise/lower mow control is disengaged, and the functional control is in the neutral position.
2. Remove your foot from the traction pedal and make sure the pedal is in the neutral position.
3. Move the throttle lever to SLOW position.
4. Insert the key into the switch and rotate it to On. Hold it in the On position until the glow plug indicator light goes off (approximately 6 seconds).
5. Immediately turn the ignition key to the Start position. Release the key when the engine starts and allow it to move to the On position. Move the throttle control to Slow.

Important: To prevent overheating of the starter motor, do not engage the starter longer than 10 seconds. After 10 seconds of continuous cranking, wait 60 seconds before engaging the starter motor again.

6. Allow the engine to warm up for a few minutes before applying load.
7. When the engine is started for the first time, or after an overhaul of the engine, operate the machine in forward and reverse for one to two minutes. Turn the steering wheel to the left and right to check the steering response. Then shut the engine off (see Stopping in Starting and Stopping the Engine) and wait for all moving parts to stop. Check for oil leaks, loose parts and any other noticeable malfunctions.

Stopping

1. Move the throttle control to Slow, disengage the raise/lower mow control, and move the functional control to neutral.
2. Rotate the starter key to Off to shut the engine off. Remove the key from the switch to prevent accidental starting.
3. Close the fuel shut-off valves before storing the machine.

Bleeding the Fuel System

1. Position the machine on a level surface. Make sure the fuel tank is at least half full.
2. Open the breather valve, on top of the canister, until fuel leaks out (Figure 35).

3. Close the breather valve.

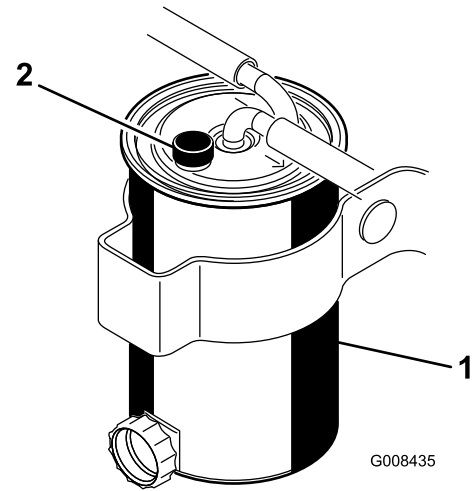

Figure 35

1. Fuel filter
2. Breather valve

4. Crank the engine for 5 seconds then pause. Repeat the procedure until the engine starts and runs smoothly.

Checking the Safety Interlock System

⚠ CAUTION

If the safety interlock switches are disconnected or damaged the machine could operate unexpectedly causing personal injury.

- Do not tamper with the interlock switches.
- Check the operation of the interlock switches daily and replace any damaged switches before operating the machine.

The purpose of the safety interlock system is to prevent operation of the machine where there is possible injury to the operator or the machine.

- The traction pedal is in neutral.
- The functional control lever is in neutral.

The safety interlock system prevents the machine from moving unless:

- The parking brake is off.
- The operator is seated.
- The functional control lever is in Mow or Transport.

The safety interlock system prevents the reels from operating unless the functional control lever is in the Mow position.

Perform the following system checks daily to be sure the interlock system is operating correctly:

1. Sit on the seat, move the traction pedal to Neutral, move the functional control lever to Neutral, and

engage the parking brake. Try to depress the traction pedal. The pedal should not depress, which means that the interlock system is operating correctly. Correct the problem if it is not operating properly.

2. Sit on the seat, move the traction pedal to Neutral, move the functional control lever to Neutral, and engage the parking brake. Move the functional control lever to mow or transport and try to start the engine. The engine should not crank, which means that the interlock system is operating correctly. Correct the problem if it is not operating properly.
3. Sit on the seat, move the traction pedal to Neutral, move the functional control lever to Neutral, and engage the parking brake. Start the engine and move the functional control lever to mow or transport. The engine should kill, which means that the interlock system is operating correctly. Correct the problem if it is not operating properly.
4. Sit on the seat, move the traction pedal to Neutral, move the functional control lever to Neutral, and engage the parking brake. Start the engine. Release the parking brake, move the functional control lever to mow, and rise from the seat. The engine should kill, which means that the interlock system is operating correctly. Correct the problem if it is not operating properly.
5. Sit on the seat, move the traction pedal to Neutral, move the functional control lever to Neutral, and engage the parking brake. Start the engine. Move the raise/lower mow control forward to lower the cutting units. The cutting units should lower but not start rotating. If they do, the interlock system is not operating correctly. Correct the problem.

GREENSMASTER 3XXX								
1	2		3		4		5	
	3.8 MPH 6.1 Km/h	5.0 MPH 8.0 Km/h	3.8 MPH 6.1 Km/h	5.0 MPH 8.0 Km/h	3.8 MPH 6.1 Km/h	5.0 MPH 8.0 Km/h	3.8 MPH 6.1 Km/h	5.0 MPH 8.0 Km/h
0.062" / 1.6mm	N/R	N/R	9	N/R	9	N/R	9	9
0.094" / 2.4mm	N/R	N/R	9	N/R	9	N/R	9	9
0.125" / 3.2mm	N/R	N/R	9	N/R	9	N/R	9	9
0.156" / 4.0mm	N/R	N/R	9	N/R	9	N/R	N/R	N/R
0.188" / 4.8mm	N/R	N/R	9	N/R	7	N/R	N/R	N/R
0.218" / 5.5mm	N/R	N/R	9	N/R	6	N/R	N/R	N/R
0.250" / 6.4mm	7	N/R	6	7	5	7	N/R	N/R
0.312" / 7.9mm	6	N/R	5	6	4	6	N/R	N/R
0.375" / 9.5mm	6	7	4	5	4	5	N/R	N/R
0.438" / 11.1mm	6	6	4	5	3	4	N/R	N/R
0.500" / 12.7mm	5	6	3	4	N/R	N/R	N/R	N/R
0.625" / 15.9mm	4	5	3	3	N/R	N/R	N/R	N/R
0.750" / 19.0mm	3	4	3	3	N/R	N/R	N/R	N/R
0.875" / 22.2mm	3	4	N/R	3	N/R	N/R	N/R	N/R
1.000" / 25.4mm	3	3	N/R	N/R	N/R	N/R	N/R	N/R

Figure 36

4. To set the reel speed, rotate the knob (Figure 37) until the indicator arrows are in line with the number designating desired setting.

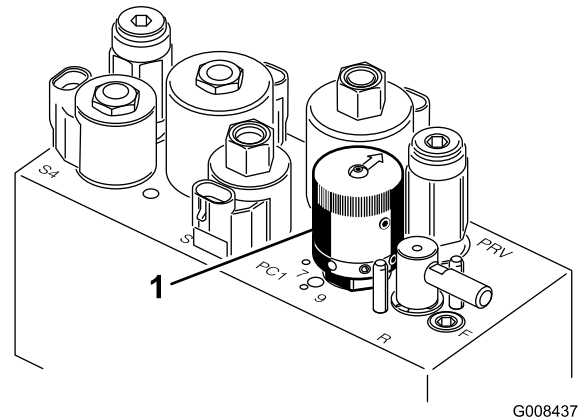

Figure 37

1. Reel speed control

Note: Reel speed can be increased or decreased to compensate for turf conditions.

Setting the Reel Speed

To achieve a consistent, high quality-of-cut and a uniform after cut appearance, it is important that the reel speed control (located on the manifold block under seat) be correctly set.

Adjust the reel speed control as follows:

1. Select the height-of-cut at which the cutting units are set.
2. Choose the desired ground speed best suited for conditions.
3. Using the appropriate graph (See Figure 36) for 5, 8, 11 or 14 blade cutting units, determine the proper reel speed setting.

Preparing the Machine for Mowing

To assist in aligning the machine for successive cutting passes, it is suggested the following be done to the No. 2 and No. 3 cutting unit baskets:

1. Measure in approximately 5 inches (12.7 cm) from the outer edge of each basket.
2. Either place a strip of white tape or paint a line onto each basket paralleling the outer edge of each basket (Figure 38).

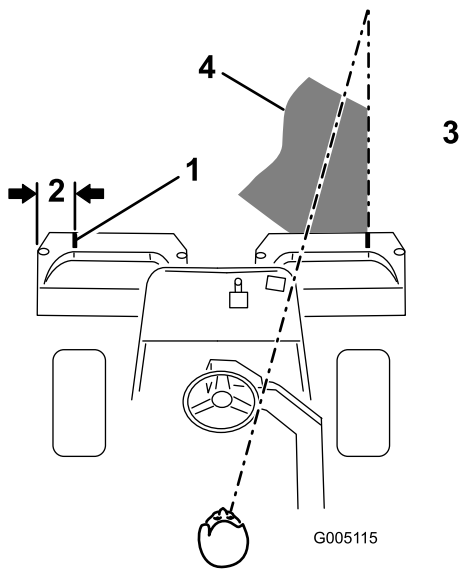

Figure 38

- | | |
|-------------------------------------|--|
| 1. Alignment strip | 3. Cut grass on right |
| 2. Approximately 5 inches (12.7 cm) | 4. Keep focal spot 6-10 ft (1.8-3 m) ahead of the machine. |

Training Period

Before mowing greens with the machine, it is recommended that you find a clear area and practice starting and stopping, raising and lowering the cutting units, turning, etc. This training period will be beneficial to the operator in gaining confidence in the performance of the machine.

Before Mowing

Inspect the green for debris, remove the flag from the cup, and determine the best direction to mow. Base the direction to mow on the previous mowing direction. Always mow in an alternate pattern from the previous mowing so that the grass blades will be less apt to lay down and therefore be difficult to trap between the reel blades and bedknife.

Mowing Procedures

1. Approach the green with the shift selector in the No. 1 position. Start on one edge of the green so that the ribbon procedure of cutting may be used. This holds compaction to a minimum and leaves a neat, attractive pattern on the greens.
2. Actuate the mow pedal as the front edge of the grass baskets cross the outer edge of the green. This procedure drops the cutting units to the turf and starts the reels.

Important: Familiarize yourself with the fact that the No. 1 cutting unit reel is delayed and therefore, you should practice to try to gain the required

timing necessary to minimize the cleanup mowing operation.

3. Overlap a minimal amount with the previous cut on return passes. To assist in maintaining a straight line across the green and keep the machine an equal distance from the edge of the previous cut, establish an imaginary sight line approximately 6 to 10 ft (1.8 to 3 m) ahead of the machine to the edge of the uncut portion of the green (Figure 39). Some find it useful to include the outer edge of the steering wheel as part of the sight line; i.e. keep the steering wheel edge aligned with a point that is always kept the same distance away from the front of the machine (Figure 39).

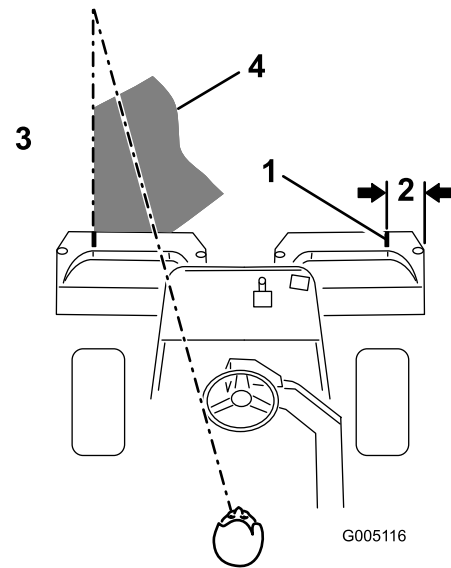

Figure 39

- | | |
|----------------------|--|
| 1. Alignment marker | 3. Keep focal spot 6-10 ft (1.8-3 m) ahead of the machine. |
| 2. Cut grass on left | |

4. As the front of the baskets cross the edge of the green, depress the lift pedal. This will stop the reels and lift the cutting units. Timing of this procedure is important, so the mowers do not cut into the fringe area. However, as much of the green as possible should be cut to minimize the amount of grass left to mow around the outer periphery
5. Cut down on operating time and ease lineup for the next pass by momentarily turning the machine in the opposite direction, then turning in the direction of the uncut portion; i.e., if intending to turn right, first swing slightly left, then right. This will assist in getting the machine more quickly aligned for the next pass. Follow the same procedure for turning in the opposite direction. It is a good practice to try to make as short of a turn as possible. However, turn in a wider arc during warmer weather to minimize the possibility of bruising the turf.

Important: The machine should never be stopped on a green with the cutting unit reels operating as damage to the turf may result. Stopping on a wet green with the machine may leave marks or indentations from the wheels.

6. Finish cutting the green by mowing the outer periphery. Be sure to change the direction of cutting from the previous mowing. Always keep weather and turf conditions in mind and be sure to change the direction of mowing from the previous cutting. Replace the flag.

At the end of the periphery cut, momentarily pull back on the raise/lower mow lever to shut the reels off without raising them. Continue moving forward until the reel stops rotating, then, drive off the green and raise the reels (This will help prevent dribbling grass onto the green while raising the reels).

Note: At the end of the periphery cut, momentarily pull back on the raise/lower mow lever to shut the reels off without raising them. Continue moving forward until the reel stops rotating, then, drive off the green and raise the reels (This will help prevent dribbling grass onto the green while raising the reels).

7. Empty the grass baskets of all clippings before transporting to the next green. Heavy wet clippings place an undue strain on the baskets and will add unnecessary weight to the machine, thereby increasing the load on the engine, hydraulic system, brakes, etc.

Transport Operation

Make sure the cutting units are in the full up position. Move the functional control lever to the transport position. Use the brakes to slow the machine while going down steep hills to avoid loss of control. Always approach rough areas at a reduced speed and cross severe undulations carefully. Familiarize yourself with the width of the machine. Do not attempt to pass between objects that are close together so that costly damage and down time can be prevented.

Inspection and Cleanup After Mowing

At the completion of the mowing operation, thoroughly wash the machine with a garden hose without a nozzle so excessive water pressure will not cause contamination and damage to seals and bearings. **Never wash a warm engine or electrical connections with water.**

After cleaning, it is recommended the machine be inspected for possible hydraulic fluid leaks and damage or wear to hydraulic and mechanical components. The cutting units should be checked for sharpness. Also, lubricate the traction pedal and brake shaft assembly with SAE 30 oil or 31 spray lubricant to deter corrosion and help keep the machine performing satisfactorily during the next mowing operation.

Towing the Machine

In case of an emergency the machine can be towed for a short distance (less than 1/4 mile (0.4 km)). However, Toro does not recommend this as standard procedure.

Important: Do not tow the machine faster than 2-3 MPH (3-5 km/h) because the drive system may be damaged. If the machine must be moved a considerable distance, transport it on a truck or trailer.

1. Locate the bypass valve on the pump and rotate it so that the slot is vertical (Figure 40).

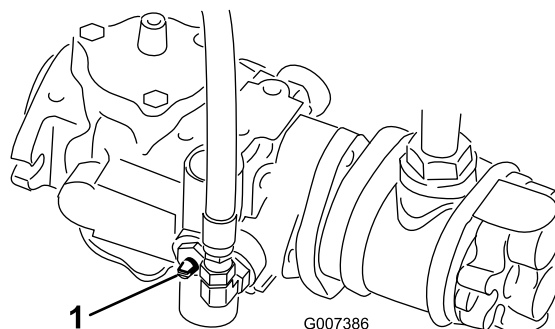

Figure 40

1. Bypass valve—slot shown in closed (horizontal) position
-
2. Before starting the engine, close the bypass valve by rotating it so that the slot is horizontal (Figure 40). Do not start the engine when the valve is open.

Maintenance

Note: Determine the left and right sides of the machine from the normal operating position.

Recommended Maintenance Schedule(s)

Maintenance Service Interval	Maintenance Procedure
After the first hour	<ul style="list-style-type: none"> • Check the torque of the wheel nuts.
After the first 8 hours	<ul style="list-style-type: none"> • Check the tension on the alternator belt.
After the first 10 hours	<ul style="list-style-type: none"> • Check the torque of the wheel nuts.
After the first 50 hours	<ul style="list-style-type: none"> • Change the engine oil and filter. • Change the hydraulic oil filter. • Check the engine RPM (at idle and full throttle).
Before each use or daily	<ul style="list-style-type: none"> • Check the engine oil. • Clean debris off of the radiator screen and radiator. Clean hourly if conditions are extremely dusty and dirty. • Check the hydraulic fluid level. • Check the reel-to-bedknife contact. • Check the hydraulic lines and hoses.
Every 25 hours	<ul style="list-style-type: none"> • Check the battery electrolyte level. (If the machine is in storage, check every 30 days.)
Every 50 hours	<ul style="list-style-type: none"> • Grease the bearings and bushings (more frequently when operating conditions are dusty or dirty) • Service the air cleaner foam pre-cleaner (more frequently when operating conditions are dusty or dirty). • Check the battery cable connections.
Every 150 hours	<ul style="list-style-type: none"> • Change the engine oil and filter.
Every 200 hours	<ul style="list-style-type: none"> • Check the torque of the wheel nuts. • Service the air cleaner cartridge (more frequently when operating conditions are dusty or dirty). • Check the reel bearing preload adjustment.
Every 800 hours	<ul style="list-style-type: none"> • Replace the filter element. • Change the hydraulic oil and filter. • Check the engine RPM (at idle and full throttle). • Check the valve clearance.
Every 2 years	<ul style="list-style-type: none"> • Check the fuel lines and connections. • Replace moving hoses.

Important: Refer to your engine operator's manual for additional maintenance procedures.

▲ CAUTION

If you leave the key in the ignition switch, someone could accidentally start the engine and seriously injure you or other bystanders.

Remove the key from the ignition.

Daily Maintenance Checklist

Duplicate this page for routine use.

Maintenance Check Item	For the week of:						
	Mon.	Tues.	Wed.	Thurs.	Fri.	Sat.	Sun.
Check the safety interlock operation.							
Check the instrument operation							
Check the brake operation.							
Check the fuel filter/water separator.							
Check the fuel level.							
Check the engine oil level.							
Clean the screen and radiator.							
Inspect the air filter.							
Check any unusual engine noises.							
Check the reel-to-bedknife adjustment.							
Check the hydraulic hoses for damage.							
Check for fluid leaks.							
Check the tire pressure.							
Check the height-of-cut adjustment.							
Lubricate all grease fittings. ¹							
Lubricate the traction and brake linkage.							
Touch-up damaged paint.							

1. Immediately after every washing, regardless of the interval listed.

Notation for Areas of Concern

Inspection performed by:		
Item	Date	Information

Lubrication

Greasing the Bearings and Bushings

Service Interval: Every 50 hours (more frequently when operating conditions are dusty or dirty)

The machine has grease fittings that must be lubricated regularly with No. 2 General Purpose Lithium Base Grease. If the machine is operated under normal conditions, lubricate all bearings and bushings **after every 50 hours** of operation. Lubricate fittings immediately after every washing, regardless of the interval listed.

The following machine bearings and bushings must be lubricated:

- Rear wheel hub (1) (Figure 41)

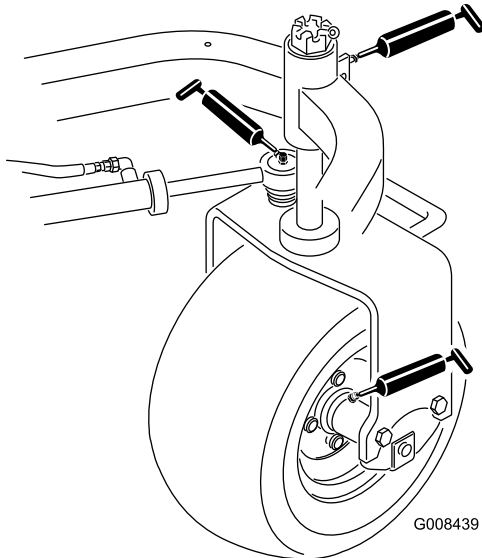

Figure 41

- Castor bearing (1) (Figure 41)
- Steering cylinder (2) (Figure 41)
- Lift arms (3) (Figure 42)

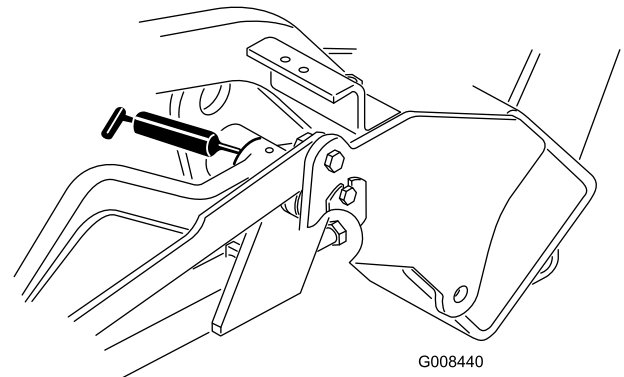

Figure 42

- Traction pedal pivot (1) (Figure 43)

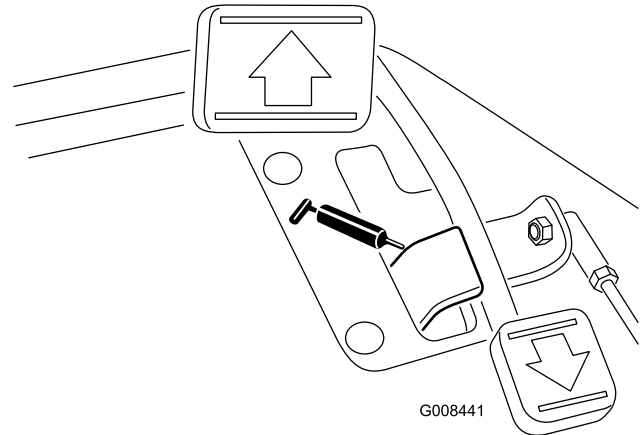

Figure 43

1. Wipe the grease fitting clean so foreign matter cannot be forced into the bearing or bushing.
2. Pump grease into the bearing or bushing.
3. Wipe up excess grease.
4. Apply grease to the reel motor spline shaft and onto the lift arm when the cutting unit is removed for service.
5. Apply a few drops of SAE 30 engine oil or spray lubricant (WD 40) daily to all pivot points after cleaning.

Note: Refer to the *Cutting Unit Operator's Manual* for cutting unit lubrication requirements.

Engine Maintenance

Servicing the Air Cleaner

Service Interval: Every 50 hours

- Check the air cleaner body for damage which could cause an air leak. Replace if damaged. Check the whole intake system for leaks, damage or loose hose clamps.
 - Service the air cleaner filter before 200 hours if the engine performance suffers due to extremely dusty, dirty conditions. Changing the air filter before it is necessary only increases the chance of dirt entering the engine when the filter is removed.
 - Be sure the cover is seated correctly and seals with the air cleaner body.
1. Release the latches securing the air cleaner cover to the air cleaner body (Figure 44).

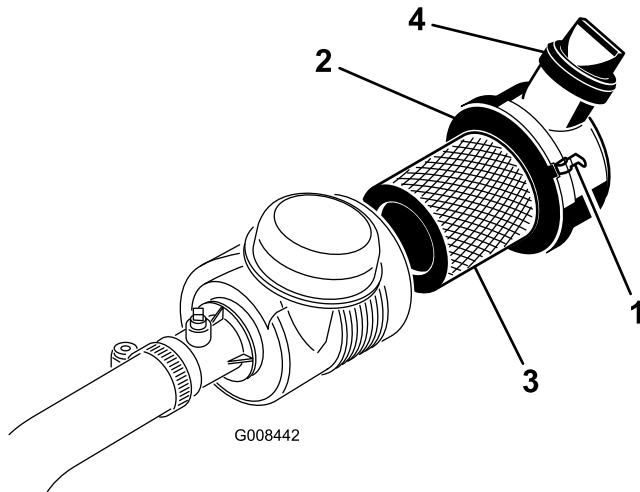

Figure 44

- | | |
|------------------------|-----------------|
| 1. Air cleaner latches | 3. Filter |
| 2. Dust cap | 4. Outlet valve |

2. Remove the cover from the air cleaner body. Before removing the filter, use low pressure air (40 psi, clean and dry) to help remove large accumulations of debris packed between outside of primary filter and the canister. Avoid using high pressure air which could force dirt through the filter into the intake tract. This cleaning process prevents debris from migrating into the intake when the primary filter is removed.
3. Remove and replace the primary filter. Cleaning of the used element is not recommended due to the possibility of damage to the filter media. Inspect the new filter for shipping damage, checking the sealing end of the filter and the body. Do not use a damaged element. Insert the new filter by applying pressure to the outer rim of the element to seat it in the canister. Do not apply pressure to the flexible center of the filter.

4. Clean the dirt ejection port located in the removable cover. Remove the rubber outlet valve from the cover, clean the cavity and replace the outlet valve.
5. Install the cover orienting the rubber outlet valve in a downward position – between approximately 5:00 to 7:00 when viewed from the end.
6. Reinstall the cover and secure the latches (Figure 44).

Changing the Engine Oil and Filter

Service Interval: After the first 50 hours

Every 150 hours

1. Remove the drain plug and let oil flow into a drain pan. When the oil stops, install the drain plug.
2. Remove the oil filter. Apply a light coat of clean oil to the new filter gasket.
3. Screw the filter on by hand until the gasket contacts the filter adapter, then tighten 1/2 to 3/4 turn further. **Do not overtighten.**
4. Add oil to the crankcase; refer to Checking the Engine Oil.
5. Dispose of the used oil properly.

Adjusting the Throttle Control

Proper throttle operation is dependent upon proper adjustment of the throttle control. Before adjusting the carburetor, ensure that the throttle control is operating properly.

1. Move the remote throttle control lever to the Slow position.
2. Loosen the cable clamp screw securing the cable to the engine (Figure 45).

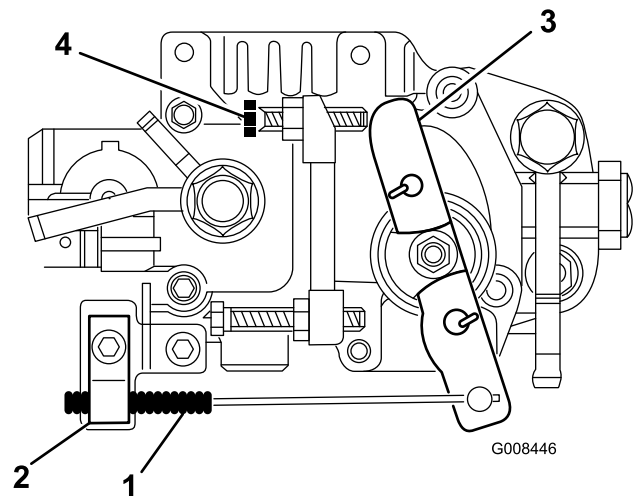

Figure 45

- | | |
|-------------------|------------------------|
| 1. Throttle cable | 3. Speed control lever |
| 2. Cable clamp | 4. Idle speed screw |

3. Move the cable until the speed control lever contacts the idle speed screw (Figure 45).
4. Tighten the cable clamp screw and check the engine RPM setting.
 - High Idle: 2925 ± 50 RPM
 - Low Idle: 1500 ± 50 RPM

Adjusting the Idle Speed

1. Move the remote throttle control lever to the Slow position.
2. Loosen the locknut on the idle speed screw (Figure 45).
3. Adjust the idle speed screw to obtain 1500 RPM.
4. Tighten the locknut.

Fuel System Maintenance

Fuel Filter/Water Separator

Service Interval: Every 800 hours

Servicing the Filter

1. Close the fuel shut off valve (Figure 46) below the fuel tank.

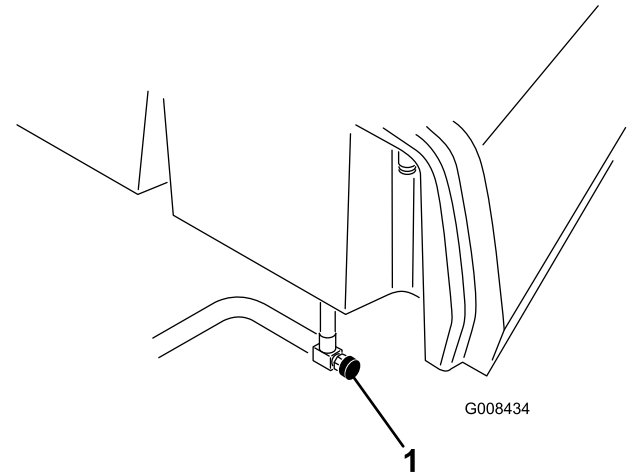

Figure 46

1. Fuel shut-off valve

2. Clean the area where the filter canister mounts (Figure 47).
3. Place a drain pan under the fuel filter.
4. Open the filter drain plug and breather valve (Figure 47).

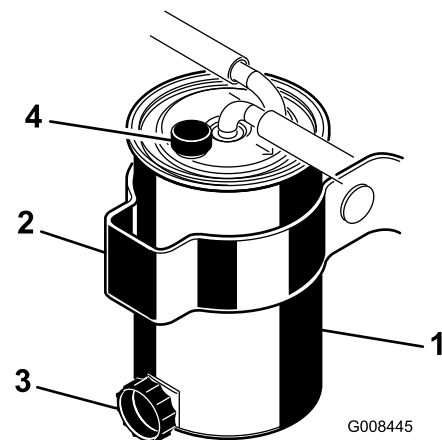

Figure 47

- | | |
|---------------------------------|----------------------|
| 1. Fuel filter /water separator | 3. Filter drain plug |
| 2. Filter mounting band | 4. Breather valve |

5. Loosen the hose clamps and disconnect the fuel lines from the top of the filter.

6. Loosen the carriage bolt on the filter mounting band and remove the filter canister. Dispose of properly.
7. Install the new filter canister and tighten the mounting band carriage bolt.
8. Install the fuel lines and clamps per the inlet and outlet markings on the top of the filter.
9. Make sure the filter drain plug is closed. Open the fuel shut off valve.
10. Bleed the fuel system. Refer to Bleeding the fuel system.

Fuel Lines and Connections

Service Interval: Every 2 years

Inspect the fuel lines for deterioration, damage, or loose connections.

Electrical System Maintenance

Servicing the Battery

WARNING

CALIFORNIA Proposition 65 Warning

Battery posts, terminals, and related accessories contain lead and lead compounds, chemicals known to the State of California to cause cancer and reproductive harm.

Wash hands after handling.

Voltage: 12 v, 530 Cold Cranking Amps

The battery electrolyte level must be properly maintained and the top of the battery kept clean. If the machine is stored in a location where temperatures are extremely high, the battery will run down more rapidly than if the machine is stored in a location where temperatures are cool.

Maintain the cell level with distilled or demineralized water. Do not fill the cells above the bottom of the split ring inside each cell.

⚠ DANGER

Battery electrolyte contains sulfuric acid which is a deadly poison and causes severe burns.

- Do not drink electrolyte and avoid contact with skin, eyes or clothing. Wear safety glasses to shield your eyes and rubber gloves to protect your hands.
- Fill the battery where clean water is always available for flushing the skin.

Keep the top of the battery clean by washing it periodically with a brush dipped in ammonia or bicarbonate of soda solution. Flush the top surface with water after cleaning it. Do not remove the fill caps while cleaning the battery.

The battery cables must be tight on the terminals to provide good electrical contact.

⚠ WARNING

Battery terminals or metal tools could short against metal tractor components causing sparks. Sparks can cause the battery gasses to explode, resulting in personal injury.

- When removing or installing the battery, do not allow the battery terminals to touch any metal parts of the tractor.
- Do not allow metal tools to short between the battery terminals and metal parts of the tractor.

⚠ WARNING

Incorrect battery cable routing could damage the tractor and cables causing sparks. Sparks can cause the battery gasses to explode, resulting in personal injury.

If corrosion occurs at the terminals, disconnect the cables, negative (-) cable first, and scrape the clamps and terminals separately. Reconnect the cables, positive (+) cable first, and coat the terminals with petroleum jelly.

- Always disconnect the negative (black) battery cable before disconnecting the positive (red) cable.
- Always connect the positive (red) battery cable before connecting the negative (black) cable.

Storing the Battery

If the machine will be stored more than 30 days, remove the battery and charge it fully. Either store it on the shelf on the machine. Leave the cables disconnected if it is stored on the machine. Store the battery in a cool atmosphere to avoid quick deterioration of the charge in the battery. To prevent the battery from freezing, make sure it is fully charged. The specific gravity of a fully charged battery is 1.265–1.299.

Fuses

The fuses in the machine's electrical system are located under the seat (Figure 48).

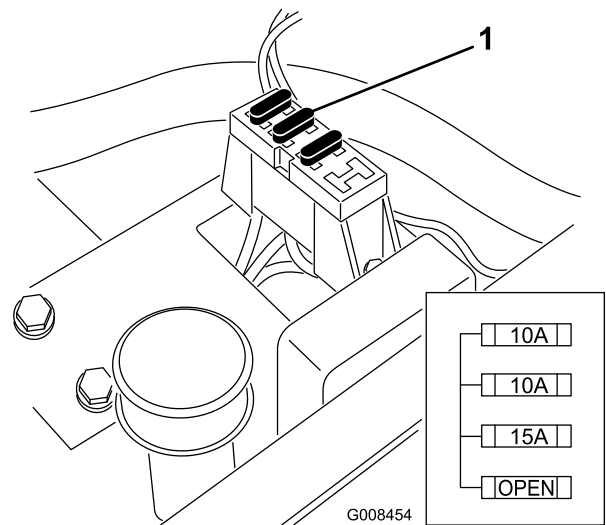

Figure 48

1. Fuses

Drive System Maintenance

Adjusting the Transmission for Neutral

If the machine creeps when the traction control pedal is in the neutral position, the neutral return mechanism must be adjusted.

1. Block up under the frame so that one of the front wheels is off of the floor.
Note: Note: If machine is equipped with a 3 wheel drive kit, also raise and block rear wheel.
2. Start the engine, move the throttle to Slow, and check the front wheel that is off of the floor; it must not be rotating.
3. If the wheel is rotating, stop the engine and proceed as follows:
 - A. Loosen both jam nuts securing the traction control cable to the bulkhead on the hydrostat (Figure 49). Make sure the jam nuts are loosened equally and sufficiently to allow adjustment.
 - B. Loosen the nut securing the eccentric to the top of the hydrostat (Figure 49).
 - C. Move the functional control lever to Neutral and the throttle to Slow. Start the engine.
 - D. Rotate the eccentric until creep does not occur in either direction. When the wheel stops rotating, tighten the nut locking the eccentric and the adjustment (Figure 49). Verify the adjustment with the throttle in the Slow and Fast position.
 - E. From each side of the bulkhead, tighten the locknuts **evenly**, securing the traction cable to the bulkhead (Figure 49). Do not twist the cable.

Note: If cable tension exists when the functional control lever is in neutral, the machine may creep when the lever is moved to the Mow or Transport position.

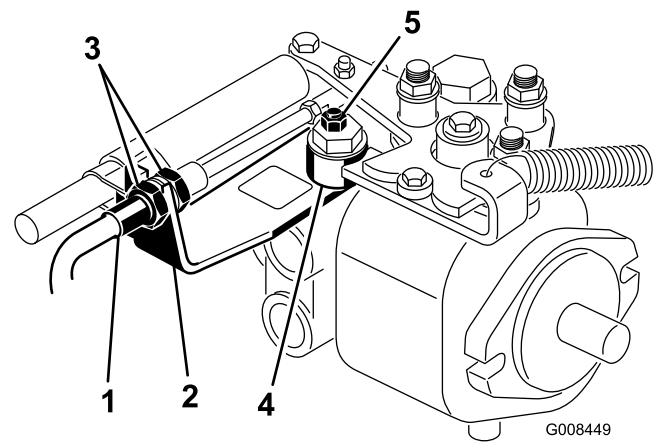

Figure 49

- | | |
|-------------------|--------------|
| 1. Traction cable | 4. Eccentric |
| 2. Bulkhead | 5. Locknut |
| 3. Jam nuts | |

Adjusting the Transport Speed

The traction pedal is adjusted for maximum transport speed at the factory, but an adjustment may be required if the pedal reaches full stroke before it contacts the pedal stop, or if a decrease in transport speed is desired.

Press down on the traction pedal. If the pedal contacts the stop (Figure 50) before tension is felt on the cable, an adjustment is required:

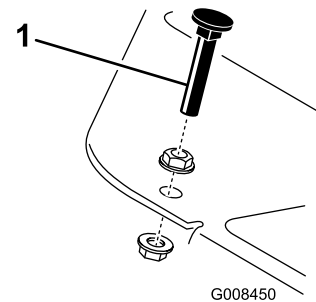

Figure 50

1. Pedal stop
 1. Loosen flangehead locknuts securing the pedal stop to the floor plate (Figure 50).
 2. Adjust the pedal stop so it contacts the pedal rod and tighten the nuts.

Adjusting the Mowing Speed

The machine is adjusted at the factory, but speed may be varied if desired.

1. Loosen the jam nut on the trunnion bolt (Figure 51).
2. Loosen the nut securing the lock and mow brackets on the pedal pivot.

Cooling System Maintenance

Cleaning the Radiator Screen

To prevent the system from overheating, the radiator screen and radiator must be kept clean. Check and clean the screen and radiator daily or, if necessary, hourly. Clean these components more frequently in dusty, dirty conditions.

1. Remove the radiator screen (Figure 52).
2. Working from the fan side of the radiator, blow out the radiator with compressed air.

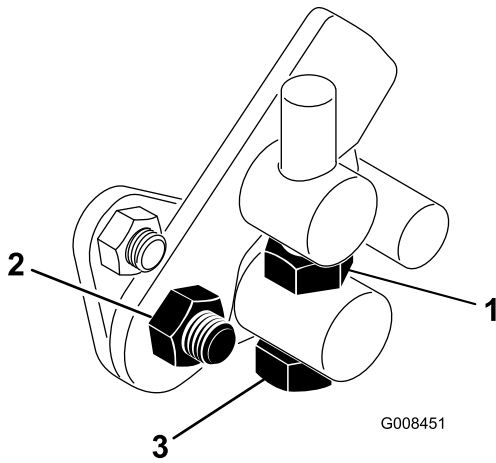

Figure 51

1. Jam nut
2. Nut
3. Trunnion bolt

3. Rotate the trunnion bolt clockwise to reduce the mowing speed and counterclockwise to increase the mowing speed.
4. Tighten the jam nut on the trunnion bolt and the nut on the pedal pivot to lock the adjustment (Figure 51). Check the adjustment and adjust as required.

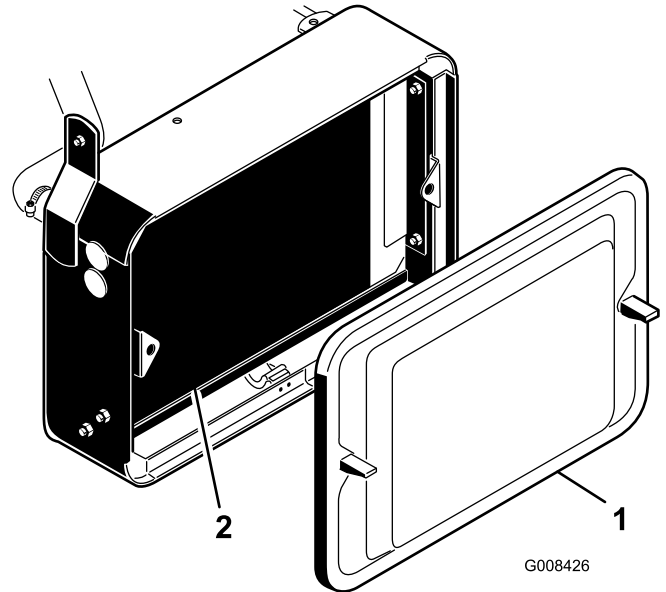

Figure 52

1. Radiator screen
2. Radiator

3. Clean the screen and reinstall it.

Brake Maintenance

Adjusting the Brakes

A brake adjustment rod is located on each side of the machine so that the brakes can be equally adjusted. Adjust the brakes as follows:

1. While moving forward in transport speed, press the brake pedal; both wheels should lock equally.

⚠ CAUTION

Testing the brakes in a confined area where others are present could cause injury.

Always check the brakes in a wide, open-spaced, flat area which is free of other persons and obstructions before and after adjustment.

2. If the brakes do not lock equally, disconnect the brake rods by removing the cotter pin and clevis pin (Figure 53).

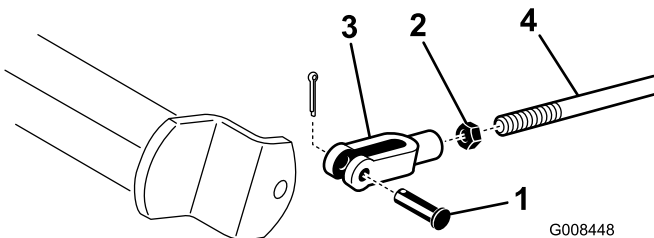

Figure 53

- | | |
|------------------------------|----------------|
| 1. Clevis pin and cotter pin | 3. Clevis |
| 2. Jam nut | 4. Brake shaft |

3. Loosen the jam nut and adjust the clevis accordingly (Figure 53).
4. Assemble the clevis to the brake shaft (Figure 53).
5. Check the amount of free travel of the brake pedal when the adjustment is completed. There should be 1/2 to 1 inch (13 to 25 mm) travel before the brake shoes make contact with the brake drums. Adjust, if necessary, to achieve this setting.
6. While moving forward in transport speed, press the brake pedal; both brakes should lock equally. Adjust, if necessary.
7. It is recommended that the brakes be burnished annually; refer to the Break-In Period section.

Belt Maintenance

Adjusting the Belt

Service Interval: After the first 8 hours

Make sure the belt is properly tensioned to ensure proper operation of the machine and prevent unnecessary wear.

1. Loosen the bolts securing the alternator to the engine and adjusting strap.

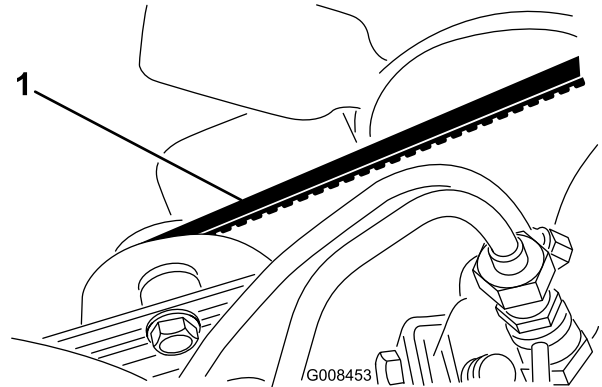

Figure 54

1. Engine belt
2. Adjust the belt to the proper tension and tighten the bolts.

Controls System Maintenance

Adjusting the Cutting Unit Lift/Drop

The cutting unit lift/drop circuit is equipped with a flow control valve (Figure 55). This valve is preset at the factory but an adjustment may be required to compensate for differences in hydraulic oil temperatures, mowing speeds, etc. If an adjustment is required, proceed as follows:

Note: Allow the hydraulic oil to reach full operating temperature before adjusting the flow control valve.

1. Raise the seat and locate the flow control valve for the center pull frame (Figure 55) which is located on the side of the hydraulic manifold.
2. Loosen the jam nut on the flow control valve.
3. Rotate the knob 1/16 turn counterclockwise if the center cutting unit is dropping too late or 1/16 turn clockwise if the center cutting unit is dropping too early.
4. After the desired setting has been achieved, tighten the jam nut.

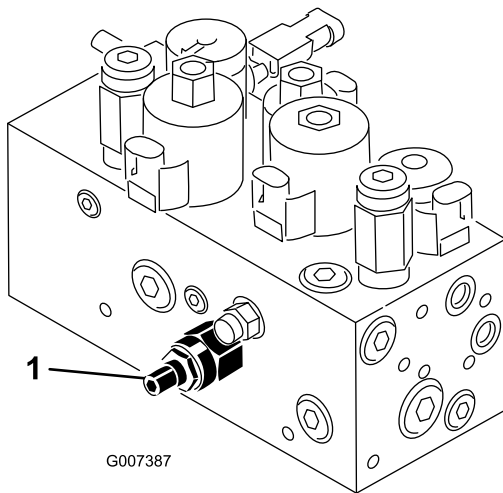

Figure 55

1. Flow control valve

Backlapping

⚠ WARNING

Contact with the reels or other moving parts can result in personal injury.

- Keep fingers, hands, and clothing away from the reels or other moving parts.
- Never attempt to turn the reels by hand or foot while the engine is running.

1. Position the machine on a level surface, lower the cutting units, stop the engine, engage the parking brake.
2. Unlock and raise the seat to expose the controls.
3. Make initial reel to bedknife adjustments appropriate for backlapping on all cutting units which are to be backlapped; refer to the *Cutting Unit Operator's Manual*.

⚠ DANGER

Changing the engine speed while backlapping may cause the reels to stall.

- Never change the engine speed while backlapping.
- Only backlap at idle engine speed.

4. Start the engine and run at low idle speed.
5. Rotate the Backlap Lever to the "R" position (Figure 56).

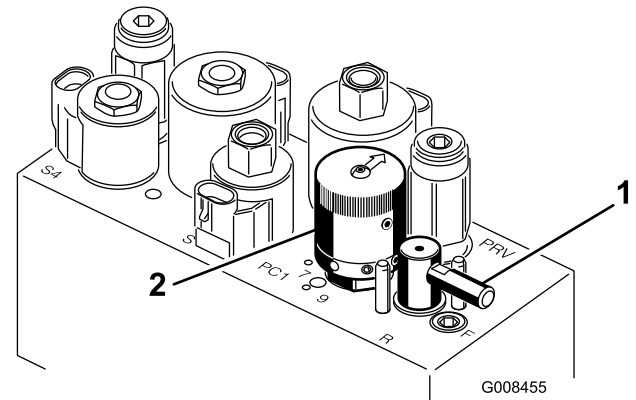

Figure 56

1. Backlap lever
2. Reel speed control

6. Rotate the Reel Speed Control to setting 1 (Figure 56).
7. With the functional control lever in the neutral position, move the Raise/Lower Mow control forward to start the backlapping operation on the designated reels.
8. Apply lapping compound with a long handle brush. Never use a short handled brush.
9. If the reels stall or become erratic while backlapping, select a higher reel speed setting until the speed stabilizes, then return the reel speed to setting 1 or to your desired speed.
10. To make an adjustment to the cutting units while backlapping, turn the reels off by moving the Raise/Lower Mow control rearward and stop the engine. After completing adjustments, repeat steps 4 through 8.
11. Repeat the procedure for all cutting units you want to backlap.
12. When finished, return the backlap levers to the "F" position, lower the seat, and wash all lapping

compound off of the cutting units. Adjust cutting unit reel to bedknife as needed. Move the cutting unit reel speed control to the desired mowing position.

Important: If the backlap lever is not returned to the “F” position after backlapping, the cutting units will not raise or function properly.

Hydraulic System Maintenance

Changing the Hydraulic Oil and Filter

Service Interval: After the first 50 hours

Every 800 hours

If the oil becomes contaminated, contact your local Toro distributor because the system must be flushed. Contaminated oil looks milky or black when compared to clean oil.

1. Clean the area around the filter mounting area (Figure 57). Place a drain pan under the filter and remove the filter.

Note: If the oil is not going to be drained, disconnect and plug the hydraulic line going to the filter.

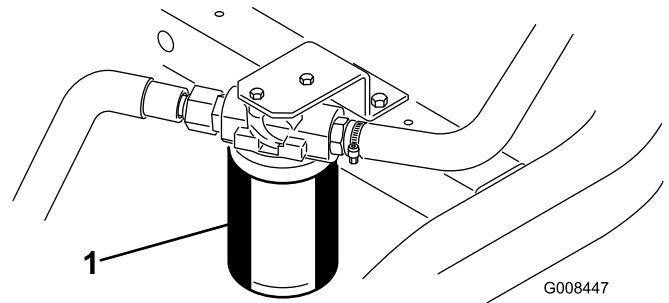

Figure 57

1. Hydraulic oil filter

2. Fill the replacement filter with the appropriate hydraulic fluid, lubricate the sealing gasket, and hand turn it until the gasket contacts the filter head. Then tighten 3/4 turn further. The filter should now be sealed.
3. Fill the hydraulic reservoir with approximately 5.5 gallons of hydraulic oil; refer to Servicing Hydraulic System Fluid.
4. Start the machine and run it at idle for 3 to 5 minutes to circulate the fluid and remove any air trapped in the system.
5. Stop the machine, recheck the fluid level and replenish as required.
6. Dispose of the oil and filter properly.

Checking the Hydraulic Lines and Hoses

⚠ WARNING

Hydraulic fluid escaping under pressure can penetrate skin and cause injury.

- **Make sure all hydraulic fluid hoses and lines are in good condition and all hydraulic connections and fittings are tight before applying pressure to the hydraulic system.**
- **Keep your body and hands away from pin hole leaks or nozzles that eject high pressure hydraulic fluid.**
- **Use cardboard or paper to find hydraulic leaks.**
- **Safely relieve all pressure in the hydraulic system before performing any work on the hydraulic system.**
- **Get immediate medical help if fluid is injected into skin.**

Check the hydraulic lines and hoses daily for leaks, kinked lines, loose mounting supports, wear, loose fittings, weather deterioration, and chemical deterioration. Make all necessary repairs before operating.

Storage

If you wish to store the machine for a long period of time, the following steps should be performed prior to storage:

1. Remove accumulations of dirt and old grass clippings. Sharpen the reels and bedknives, if necessary; refer to the *Cutting Unit Operator's Manual*. Use a rust preventive on bedknives and reel blades. Grease and oil all lubrication points; refer to Lubrication.
2. Block up the wheels to remove any weight on the tires.
3. Drain and replace the hydraulic fluid and filter and inspect the hydraulic lines and fittings. Replace, if necessary; refer to Changing the Hydraulic Oil and Filter and Checking the Hydraulic Lines and Hoses.
4. All fuel should be removed from the fuel tank. Run the engine until it stops from lack of fuel. Replace the fuel filter; refer to Replacing the Fuel Filter.
5. While the engine is still warm, drain the oil from the crankcase. Refill it with fresh oil; refer to Changing the Engine Oil and Filter.
6. Clean dirt and chaff from the cylinder, cylinder head fins, and blower housing.
7. Remove the battery and charge it fully. Either store it on the shelf or on the machine. Leave the cables disconnected if it is stored on the machine. Store the battery in a cool atmosphere to avoid quick deterioration of the charge in the battery.
8. If possible, store the machine in a warm, dry location.

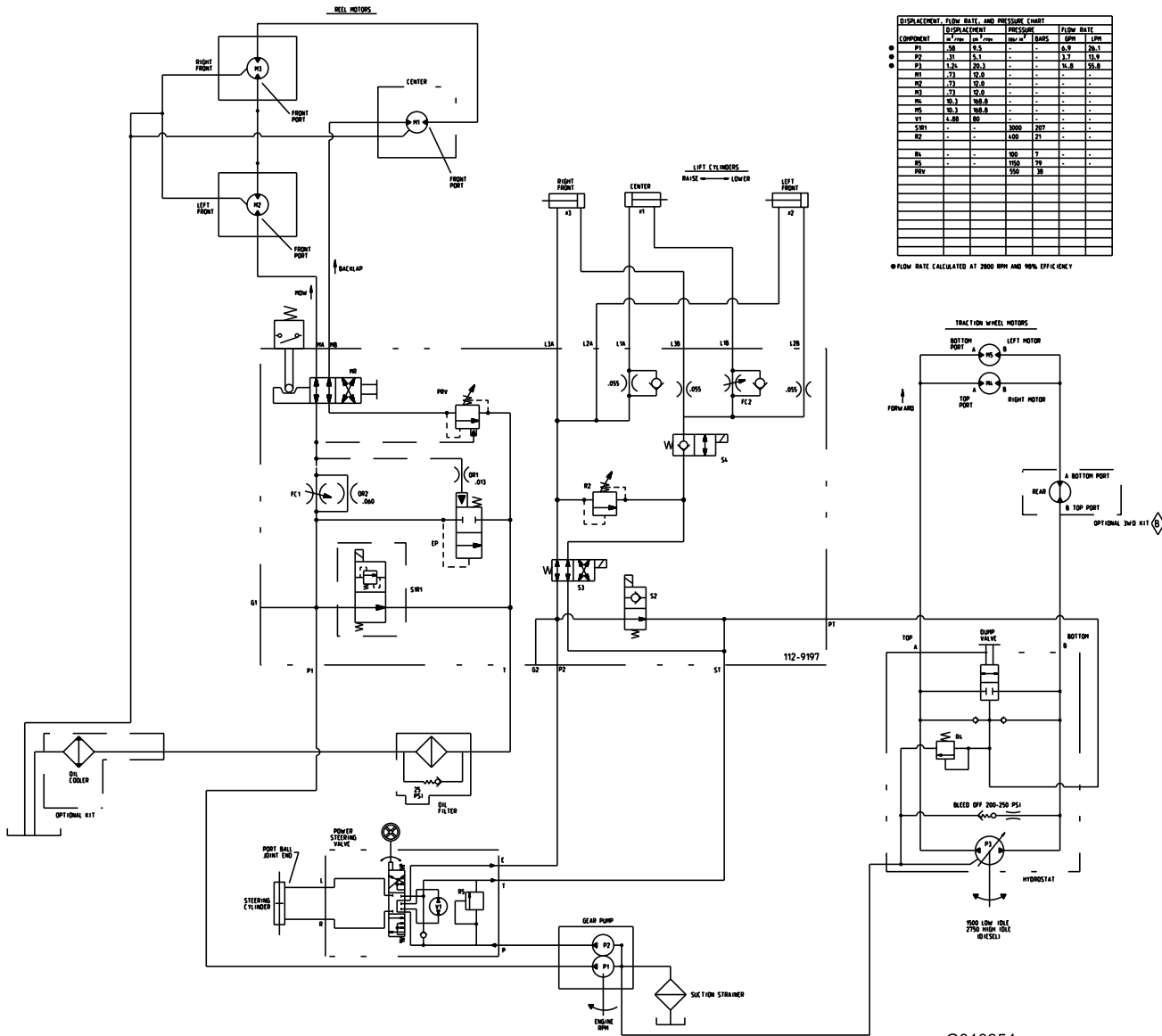

Hydraulic Schematic (Rev. D)

G010354



The Toro Total Coverage Guarantee

A Limited Warranty

Conditions and Products Covered

The Toro® Company and its affiliate, Toro Warranty Company, pursuant to an agreement between them, jointly warrant your Toro Commercial product ("Product") to be free from defects in materials or workmanship for two years or 1500 operational hours*, whichever occurs first. This warranty is applicable to all products with the exception of Aerators (refer to separate warranty statements for these products). Where a warrantable condition exists, we will repair the Product at no cost to you including diagnostics, labor, parts, and transportation. This warranty begins on the date the Product is delivered to the original retail purchaser.

* Product equipped with an hour meter.

Instructions for Obtaining Warranty Service

You are responsible for notifying the Commercial Products Distributor or Authorized Commercial Products Dealer from whom you purchased the Product as soon as you believe a warrantable condition exists. If you need help locating a Commercial Products Distributor or Authorized Dealer, or if you have questions regarding your warranty rights or responsibilities, you may contact us at:

Commercial Products Service Department
Toro Warranty Company
8111 Lyndale Avenue South
Bloomington, MN 55420-1196
E-mail: commercial.warranty@toro.com

Owner Responsibilities

As the Product owner, you are responsible for required maintenance and adjustments stated in your Operator's Manual. Failure to perform required maintenance and adjustments can be grounds for disallowing a warranty claim.

Items and Conditions Not Covered

Not all product failures or malfunctions that occur during the warranty period are defects in materials or workmanship. This warranty does not cover the following:

- Product failures which result from the use of non-Toro replacement parts, or from installation and use of add-on, or modified non-Toro branded accessories and products. A separate warranty may be provided by the manufacturer of these items.
- Product failures which result from failure to perform recommended maintenance and/or adjustments. Failure to properly maintain your Toro product per the Recommended Maintenance listed in the *Operator's Manual* can result in claims for warranty being denied.
- Product failures which result from operating the Product in an abusive, negligent or reckless manner.
- Parts subject to consumption through use unless found to be defective. Examples of parts which are consumed, or used up, during normal Product operation include, but are not limited to, brakes pads and linings, clutch linings, blades, reels, bed knives, tines, spark plugs, castor wheels, tires, filters, belts, and certain sprayer components such as diaphragms, nozzles, and check valves, etc.
- Failures caused by outside influence. Items considered to be outside influence include, but are not limited to, weather, storage practices, contamination, use of unapproved coolants, lubricants, additives, fertilizers, water, or chemicals, etc.
- Normal noise, vibration, wear and tear, and deterioration.
- Normal "wear and tear" includes, but is not limited to, damage to seats due to wear or abrasion, worn painted surfaces, scratched decals or windows, etc.

Countries Other than the United States or Canada

Customers who have purchased Toro products exported from the United States or Canada should contact their Toro Distributor (Dealer) to obtain guarantee policies for your country, province, or state. If for any reason you are dissatisfied with your Distributor's service or have difficulty obtaining guarantee information, contact the Toro importer. If all other remedies fail, you may contact us at Toro Warranty Company.

Parts

Parts scheduled for replacement as required maintenance are warranted for the period of time up to the scheduled replacement time for that part. Parts replaced under this warranty are covered for the duration of the original product warranty and become the property of Toro. Toro will make the final decision whether to repair any existing part or assembly or replace it. Toro may use remanufactured parts for warranty repairs.

Note Regarding Deep Cycle Battery Warranty:

Deep cycle batteries have a specified total number of kilowatt-hours they can deliver during their lifetime. Operating, recharging, and maintenance techniques can extend or reduce total battery life. As the batteries in this product are consumed, the amount of useful work between charging intervals will slowly decrease until the battery is completely worn out. Replacement of worn out batteries, due to normal consumption, is the responsibility of the product owner. Battery replacement may be required during the normal product warranty period at owner's expense.

Maintenance is at Owner's Expense

Engine tune-up, lubrication cleaning and polishing, replacement of Items and Conditions Not Covered filters, coolant, and completing Recommended Maintenance are some of the normal services Toro products require that are at the owner's expense.

General Conditions

Repair by an Authorized Toro Distributor or Dealer is your sole remedy under this warranty.

Neither The Toro Company nor Toro Warranty Company is liable for indirect, incidental or consequential damages in connection with the use of the Toro Products covered by this warranty, including any cost or expense of providing substitute equipment or service during reasonable periods of malfunction or non-use pending completion of repairs under this warranty. Except for the Emissions warranty referenced below, if applicable, there is no other express warranty.

All implied warranties of merchantability and fitness for use are limited to the duration of this express warranty. Some states do not allow exclusions of incidental or consequential damages, or limitations on how long an implied warranty lasts, so the above exclusions and limitations may not apply to you.

This warranty gives you specific legal rights, and you may also have other rights which vary from state to state.

Note regarding engine warranty:

The Emissions Control System on your Product may be covered by a separate warranty meeting requirements established by the U.S. Environmental Protection Agency (EPA) and/or the California Air Resources Board (CARB). The hour limitations set forth above do not apply to the Emissions Control System Warranty. Refer to the Engine Emission Control Warranty Statement printed in your *Operator's Manual* or contained in the engine manufacturer's documentation for details