



Hanger Bracket Upgrade Kit

2011-2012 XLS Lawn Tractor

Model No. 121-4016

Installation Instructions

Installation

Loose Parts

Use the chart below to verify that all parts have been shipped.

Description	Qty.	Use
Hanger bracket, left rear	1	Install the kit.
Hanger bracket, right rear	1	
Deck support bracket	2	
Clevis pin	2	
Cotter pin	2	
Shoulder bolt	2	
Locknut	2	
Flat washer	2	

Installing the Kit

1. Stop the engine, wait for all moving parts to stop, and remove the ignition key.
2. Remove the mower deck as described in your *Operator's Manual*.
3. Remove the existing hanger brackets from the deck brackets (Figure 1).

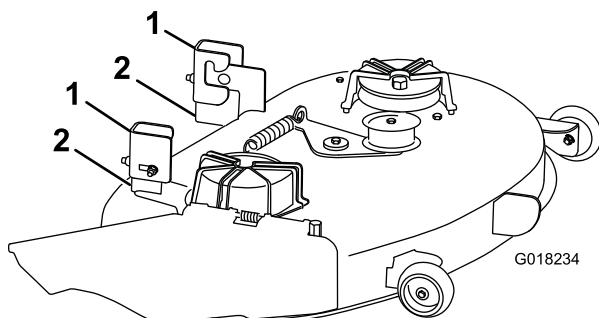

Figure 1

1. Hanger bracket
2. Deck bracket

Note: Save the hardware for installing the new hanger brackets.

4. **For Model 71254 only:** If you have a 38-inch mower deck (for model 71254), you must remove part of the rear left-hand deck bracket so that the new hanger bracket will fit and allow the mower deck to be raised or lowered freely. Do the following steps:

- A. To aid in removing material from the rear left-hand deck bracket, drill a 1/2-inch (13 mm) hole in the bracket at the location shown in Figure 2.

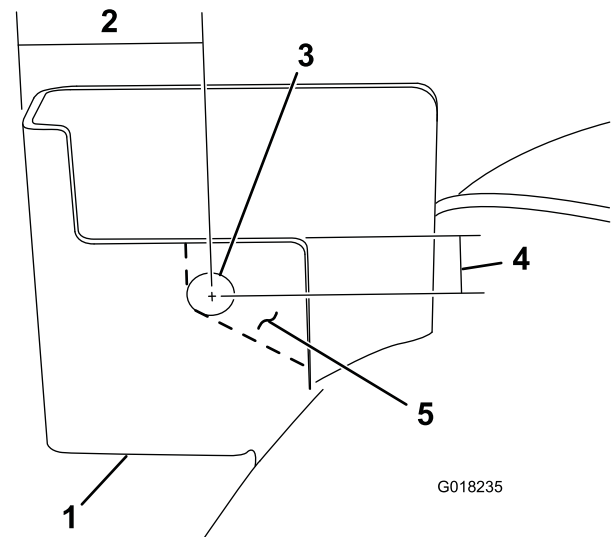

Figure 2

1. Hanger bracket
2. 2 inches (51 mm)
3. 1/2-inch (13 mm) hole
4. 5/8 inch (16 mm)
5. Material removed

- B. Remove the portion of the rear left-hand deck bracket as shown in Figure 2.

Note: File away sharp edges and burrs, and apply Toro touchup paint to any areas where bare metal has been exposed.

5. Install the new hanger brackets on the deck brackets as shown in Figure 3 and Figure 4.

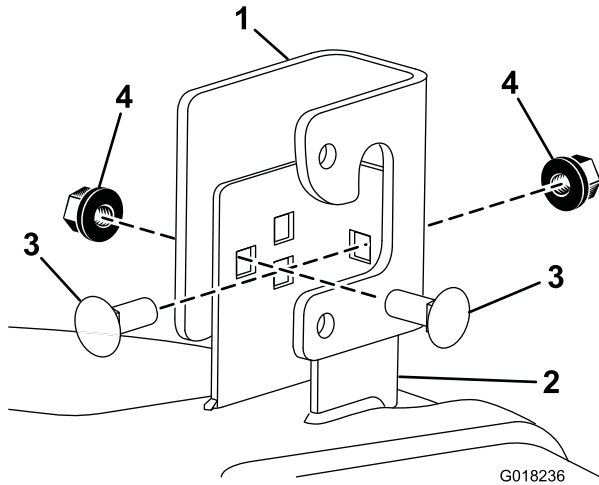

Figure 3

Rear right-hand side shown from the left side

- | | |
|-------------------|-----------------------------|
| 1. Hanger bracket | 3. Carriage bolt (existing) |
| 2. Deck bracket | 4. Nut (existing) |

Note: Install the shoulder bolt through the upper hole in each hanger bracket (Figure 5).

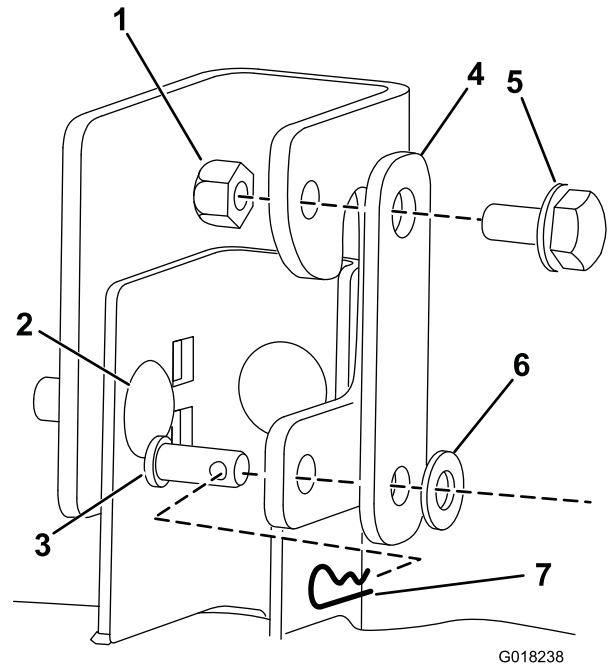

Figure 5

Rear right-hand side shown

- | | |
|-----------------------------|------------------|
| 1. Locknut | 5. Shoulder bolt |
| 2. Carriage bolt (existing) | 6. Flat washer |
| 3. Clevis pin | 7. Cotter pin |
| 4. Deck support bracket | |

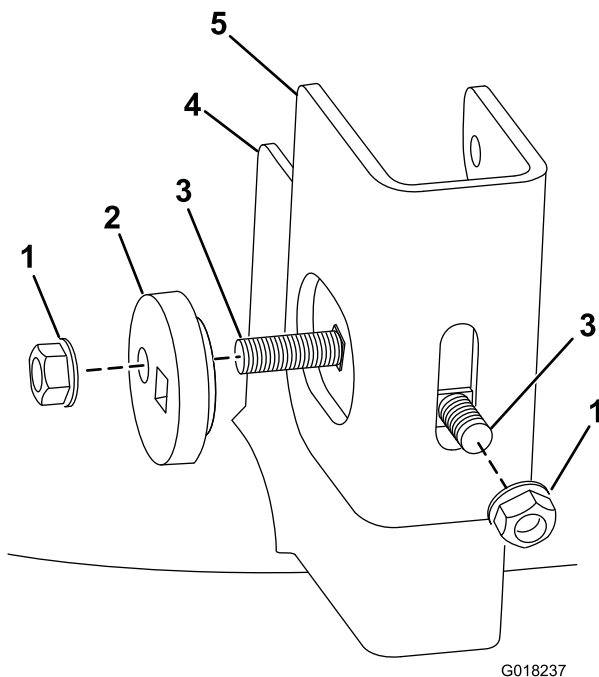

Figure 4

Rear left-hand side shown from the rear

- | | |
|-----------------------------|-------------------|
| 1. Nut (existing) | 4. Deck bracket |
| 2. Eccentric | 5. Hanger bracket |
| 3. Carriage bolt (existing) | |

6. Install a deck support bracket on each hanger bracket with a shoulder bolt and a locknut (Figure 5).

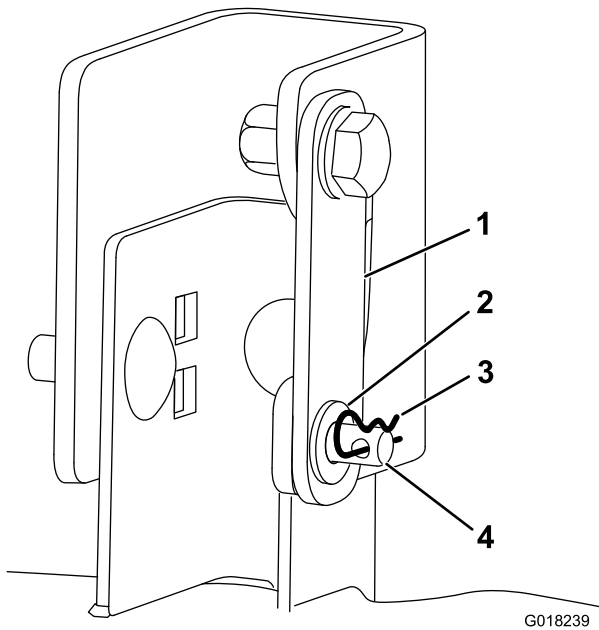

Figure 6

Rear lift rod not shown

- | | |
|-------------------------|---------------|
| 1. Deck support bracket | 3. Cotter pin |
| 2. Flat washer | 4. Clevis pin |

-
8. Install the mowing deck and adjust both the side-to-side level and the front-to-rear blade slope. See the chapter on Blade Maintenance in the *Operator's Manual* for the following procedures: Installing the Mower, Leveling the Mower from Side-to-Side, and Adjusting the Front-to-Rear Blade Slope.



Count on it.