



ProLine

Mid Size Traction Unit

14 H.P. Kohler Gear Drive

Model No. 30177 – 790001 & Up

PROTOTYPE

Parts Catalog

ORDERING REPLACEMENT PARTS

To order replacement parts, please supply: the part number, the quantity, and the description of each part desired.

Contents

Description	Page	Description	Page
Fuel Tank & Idler Bracket Assembly	1	Oil Pan / Lubrication	10
Transmission & Idler Pulley Assembly	2	Cylinder Head, Valve & Breather	11
Brake, Wheel Pulley & Wheel Assembly	3	Ignition / Electrical	12
Wheel And Tire Asm	4	Blower Housing & Baffles	13
Handle & Control Panel Assembly	5	Starter System	14
Engine Assembly	6	Air Cleaner	15
Clutch Asm No. 54-3200	7	Carburetor	16
Peerless Transmission Model No. 700-039	8	Engine Controls	17
Crankcase	9	Exhaust	18

Note:

Part Description Abbreviations

Part descriptions in this catalog may include the following abbreviations.

Abbreviation	Meaning	Abbreviation	Meaning
AR	as required	HWHTF	hex washer head thread forming
ASM	assembly	INC	incorporated
CARR	carriage	LH	left hand
DEG	degrees	PH	pan head
FH	flat head	PPH	Phillips pan head
GA	gauge	PTO	power take off
HF	hex flange	RH	right hand
HFW	hex flange washer	SFH	slotted fillister head
HH	hex head	SH	square head
HHF	hex head flange	SHWH	slotted hex washer head
HHST	hex head self tapping	SPH	slotted pan head
HJ	hex jam	STD	standard
HOC	height-of-cut	TAP	self tapping
HS	hex socket	TH	truss head
HSBH	hex socket button head	TTH	Torx truss head
HSFH	hex socket flat head	WH	wing head
HSH	hex socket head		
HWH	hex washer head		

Important Format Explanations

This catalog uses special formats to convey information in illustrations and parts lists. Specifically, one format is used in conjunction with service assemblies and another with quantities associated with reference numbers.

Service Assemblies

Parts within service assemblies have reference numbers in the form $X:Y$. X is the reference number of the service assembly and Y is a sequential number unique to each part within the service assembly.

For example, a wheel assembly might be identified by reference number 6, the tire by 6:1, the valve by 6:2, and the wheel by 6:3. When you order the assembly identified by reference number 6, you receive all parts identified by reference numbers 6:1, 6:2, and 6:3. However, you may also order any part individually.

Reference numbers of this type appear in part lists and as callouts in illustrations.

PROTOTYPE

Reference Numbers with Quantities

Illustrations may have a quantity in parentheses next to a reference number, in the form $X (Y)$. X is the reference number. Y in parentheses is the quantity of the part identified by the reference number.

For example, the illustration callout 4 (2) indicates that two parts are used in that instance.

PROTOTYPE

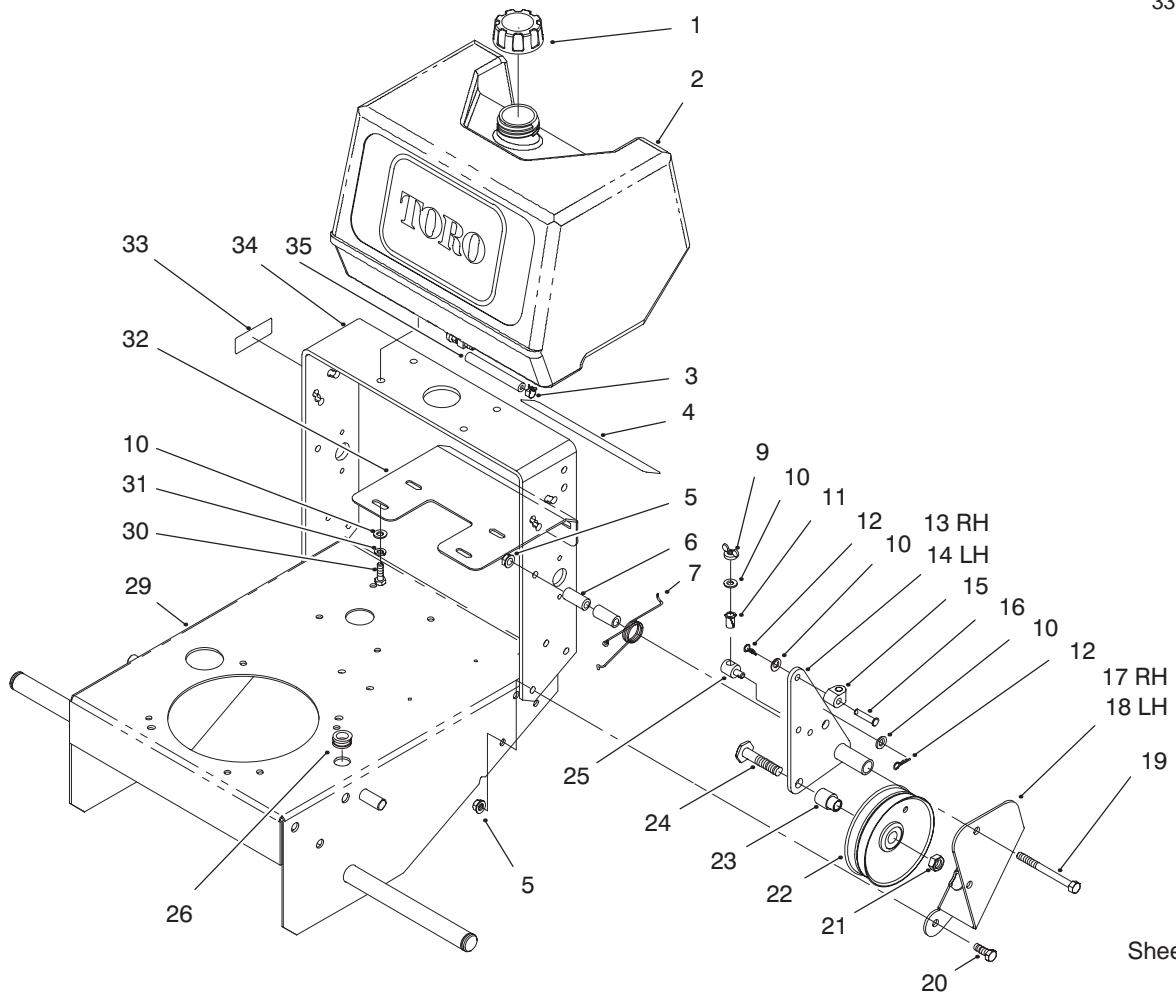

Sheet No.: 2

Fuel Tank & Idler Bracket Assembly

Ref. No.	Part No.	Qty.	Description
1	55-3570	1	ASM-Cap
2	95-2802	1	Tank-Fuel
3	2412-98	2	Clamp-Hose
4	82-7750	1	Decal-Ground Speed
5	3296-39	8	Nut-Lock
6	74-0040	4	Spacer-Pivot
7	51-4370	1	Spring-Torsion
8	51-4380	1	Spring-Torsion
9	32103-25	2	Nut-Wing
10	3256-23	10	Washer-Flat
11	52-2890	2	Bushing-Steering Links
12	3290-307	4	Pin-Cotter
13	74-0230	1	Idler Bracket RH
14	74-0220	1	Idler Bracket LH
15	74-0521	2	Rod-Fitting
16	283-6	2	Pin-Clevis
17	67-6370	1	Bracket-Support
18	67-6380	1	Bracket-Support
19	323-16	2	Screw-HH
20	323-6	6	Screw-HH
21	3296-23	2	Nut-Lock
22	95-2800	2	Pulley-Idler
23	95-2801	2	Spacer-Pulley
24	51-4450	2	Screw-Leveler
25	68-9690	2	Fitting Rod

Ref. No.	Part No.	Qty.	Description
26	237-124	1	Grommet
28	3269-8	2	Rivet
29	93-1156	1	Frame
30	322-4	4	Screw-HH
31	3253-4	4	Washer-Lock
32	66-7400	1	Plate-Control
33	95-2814	1	Decal-Fuel Shut-Off
34	74-0360	1	Frame-Rear
35	47-2964	1	Hose-Gas

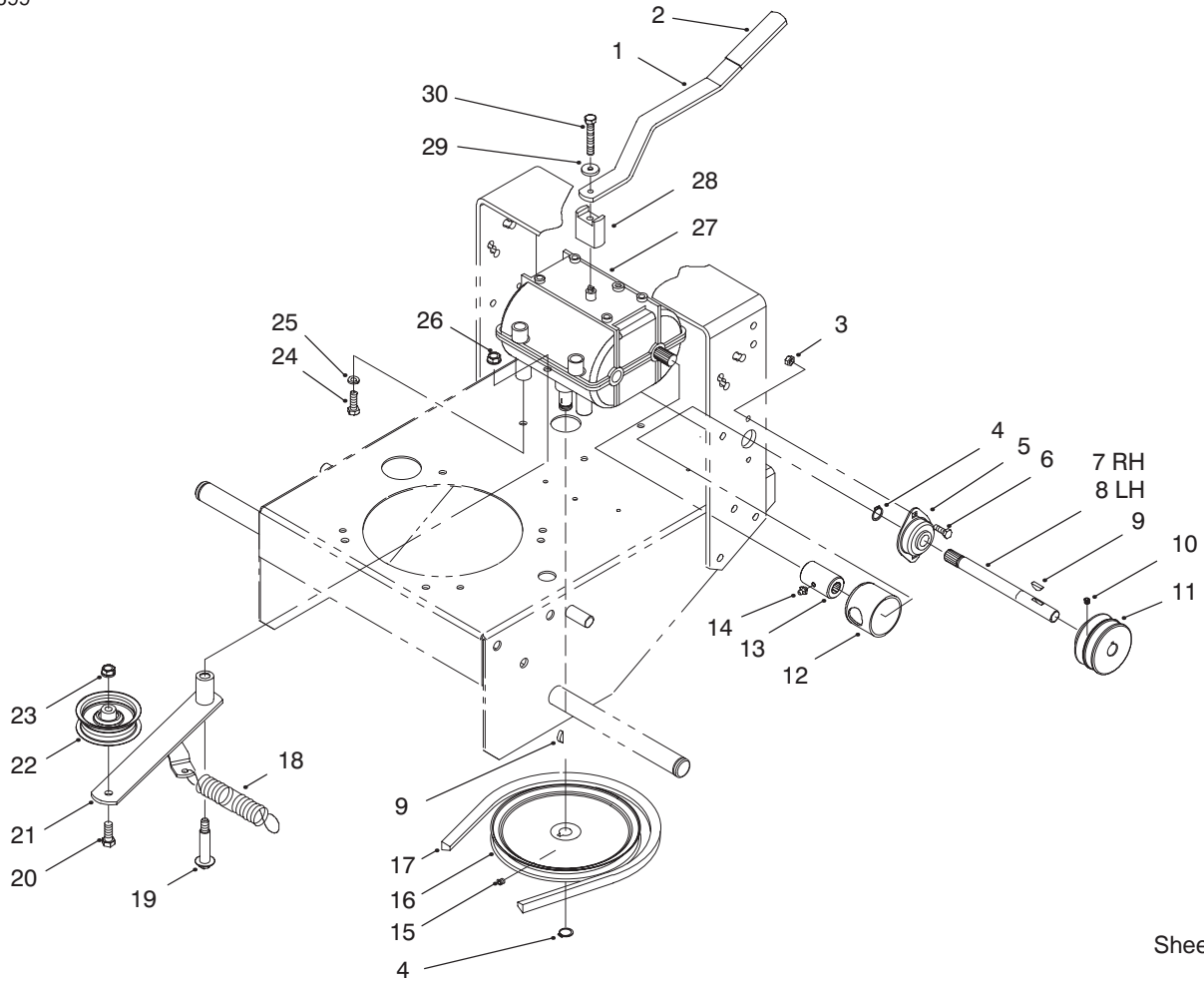

Sheet No.: 3

Transmission & Idler Pulley Assembly

Ref. No.	Part No.	Qty.	Description
1	74-0320	1	Lever-Shift
2	47-1970	1	Grip-Engagement
3	3296-42	4	Nut-Lock
4	32120-64	3	Ring-Retaining
5	51-4270	2	Bearing-Shaft Ext
6	321-4	4	Screw-HH
7	51-4240	1	Shaft-Extension
8	51-4250	1	Shaft-Extension
9	3257-5	3	Key-Woodruff
10	3245-3	2	Screw-HSH
11	74-0480	2	Pulley-Drive ASM
12	51-4220	2	Guard-Coupler
13	51-4260	2	Coupler
14	302-5	2	Fitting-Grease
15	3245-1	1	Screw-Set
16	51-4190	1	Pulley-Drive
17	26-9671	1	"v" Belt
18	68-2190	1	Spring-Extension
19	27-6230	1	Bolt-Wheel
20	323-8	1	Screw-HH
21	82-4800	1	Lever-Idler
22	62-4540-03	1	Pulley-Idler
23	3296-39	1	Nut-Lock
24	322-2	4	Screw-HH
25	3253-4	4	Washer-Lock
26	3296-6	1	Nut-Lock

Ref. No.	Part No.	Qty.	Description
27	74-0610	1	Transmission
28	72-2190	1	Mount-Shift Lever
29	7-5461	1	Spacer-Transmission
30	329-10	1	Screw

PROTOTYPE

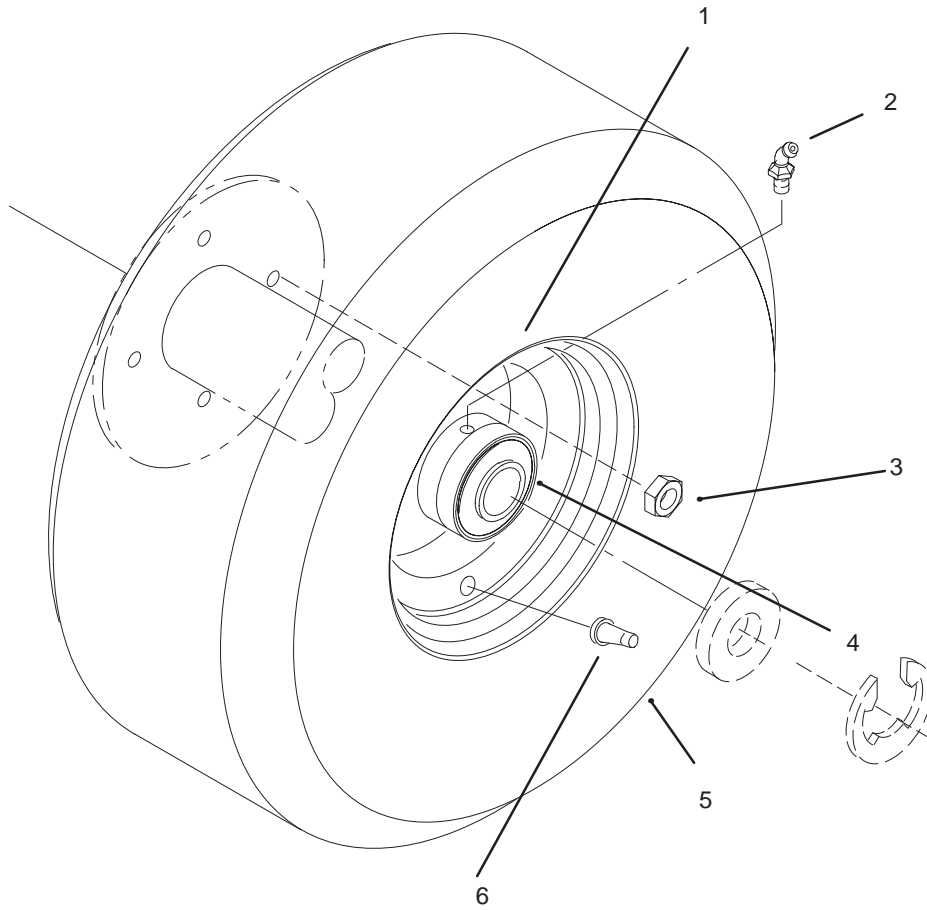

Sheet No.: 500

Wheel And Tire Asm

Ref. No.	Part No.	Qty.	Description
1	242-80	2	Rim
2	302-11	2	Fitting-Grease
3	3296-29	8	Nut-Lock
4	92-1746	4	Bearing
5	231-117	2	Tire-15x6
6	232-27	2	Valve Stem & Cap Assembly

Ref. No.	Part No.	Qty.	Description

PROTOTYPE

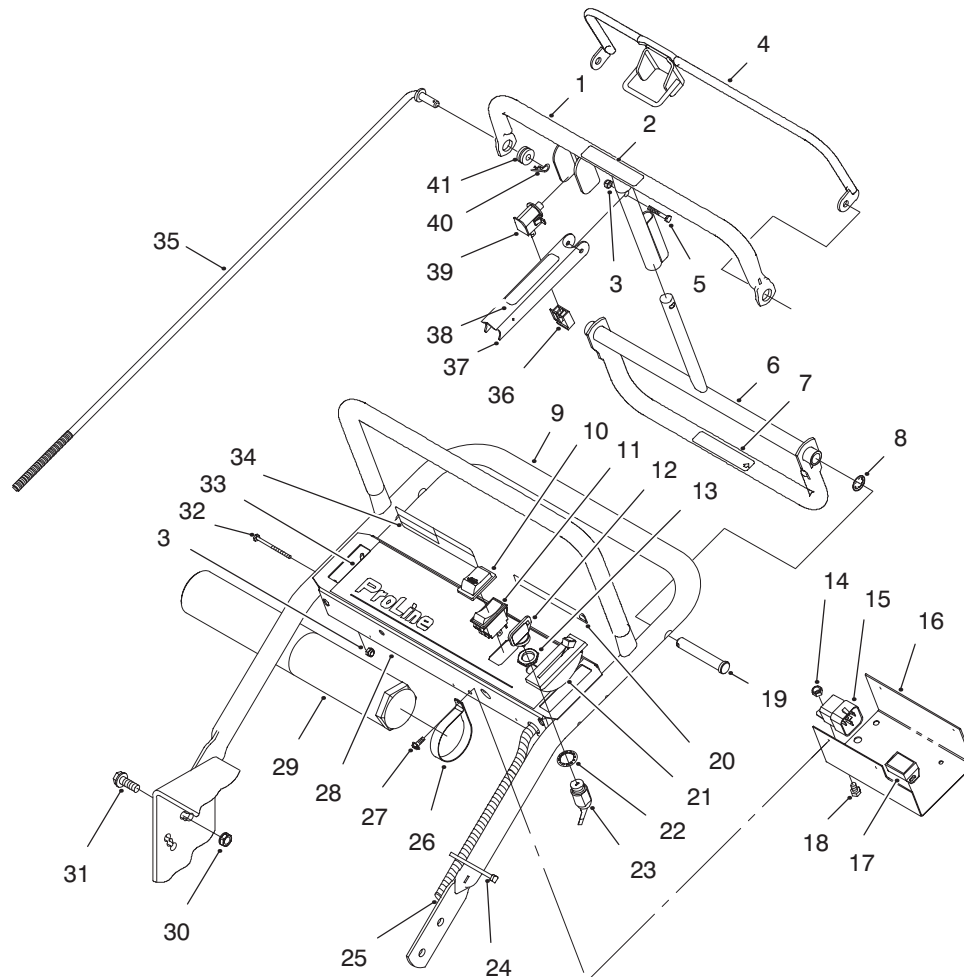

Sheet No.: 5

Handle & Control Panel Assembly

Ref. No.	Part No.	Qty.	Description	Ref. No.	Part No.	Qty.	Description
1	82-7690	1	Bar	27	32104-76	4	Screw-Self TAP
2	82-2290	1	Decal-Control Bar	28	82-2180-03	1	Panel-Control
3	3296-2	5	Nut Lock	29	74-0720	1	Tube-Manual
4	82-7680	1	Bail	30	32128-21	4	Nut-HF
5	32105-1	1	Screw-HH	31	3234-11	4	Screw-HHF
6	74-0380	1	Control Pivot	32	32105-14	4	Screw-HH
7	82-2280	1	Decal-Reverse	33	82-7730	1	Decal-Panel Proline
8	32151-80	2	Ring-Push On	34	71-1280	1	Decal-Warning
9	67-6440	1	Handle-Upper	35	82-7631	2	Rod-Control
10	82-3820	1	Boot-Switch	36	218-595	1	Connector-Body
11	82-2300	1	Switch	37	51-4850	1	Lever-Parking Brake
12	63-8360	2	Key-Ignition	38	52-2010	1	Decal-Parking Lever
13	218-461	1	Nut-HH	39	82-2190	1	Switch-Bail
14	3296-42	1	Nut-Lock	40	3290-307	2	Pin-Cotter
15	63-7590	1	Relay	41	237-141	2	Grommet
16	93-1187-03	1	Panel-Bottom				
17	94-9666	1	Module				
18	321-2	1	Screw-HH				
19	283-55	2	Pin-Clevis				
20	65-3090	1	Decal-Read Manual				
21	74-0630	1	Control-Throttle				
22	3254-5	1	Washer-Lock				
23	29-5560	1	Switch-On/Off				
24	3290-378	2	Tie-Cable				
25	95-2803	1	Wire Harness				
26	2412-120	2	Clamp-"R"				

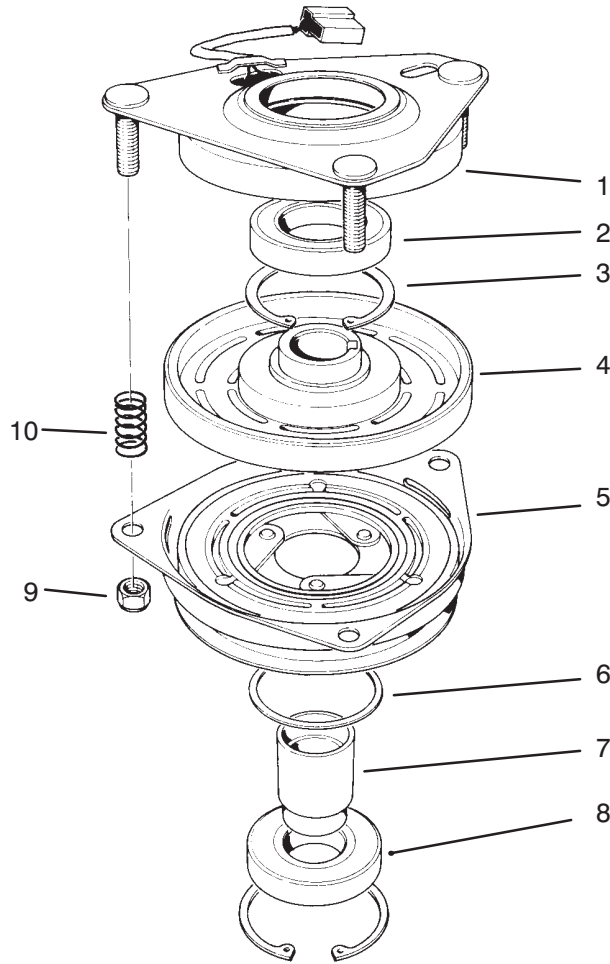

Sheet No.: 301

Clutch Asm No. 54-3200

Ref. No.	Part No.	Qty.	Description
1	54-0230	1	Field ASM Inc2/3
2	251-292	1	Bearing
3	44-8310	2	Ring-Retaining
4	44-8360	1	Field Coil & Bearing
5	55-7410	1	Armature & Pulley ASM
6	44-8330	1	Spacer-Pulley Bearing
7	44-8340	1	Collar-Bearing
8	251-291	1	Bearing-Pulley
9	3296-5	3	Nut-Lock
10	44-8320	3	Spring

Ref. No.	Part No.	Qty.	Description

PROTOTYPE

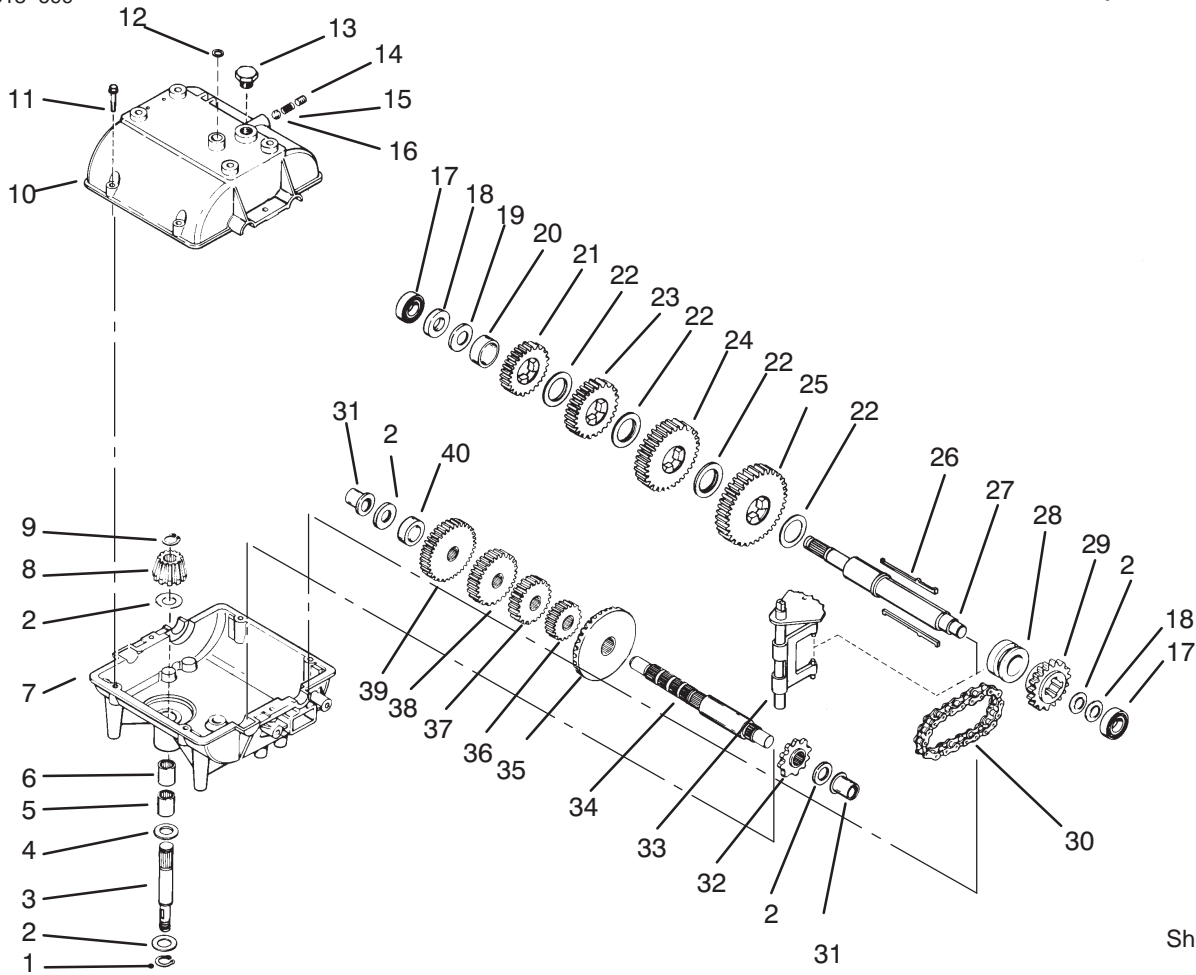

Sheet No.: 101
C-1776

Peerless Transmission Model No. 700-039

Ref. No.	Part No.	Qty.	Description
1	792035	1	Ring-Retaining
2	780072	5	Washer
3	776135	1	Shaft-Input
4	792001	2	O Ring
5	780142	1	Bearing-Needle
6	780086	1	Bearing-Needle
7	770090A	1	Case-Transmission
8	778153	1	Bevel Pinion-Input
9	788040	1	Ring-Retaining
10	772099A	1	Cover-Transmission
11	792073	6	Screw 1/4-20x1 1/4
12	788069	1	Ring-Square Cut
13	792074	1	Plug-Threaded
14	792078	1	Screw-Set 9/16-18
15	792079	11	Spring
16	792077	1	Ball-Steel
17	780092	2	Bearing-Ball
18	780065	2	Washer-Thrust
19	780139	1	Washer-Thrust
20	786072	1	Spacer
21	778123A	1	Gear-Spur 25teeth
22	780108	4	Washer
23	778250	1	Gear-Spur 27 Teeth
24	778124A	1	Gear-Spur 30 Teeth

Ref. No.	Part No.	Qty.	Description
25	778125	1	Gear Spur 35 Teeth
26	792089A	4	Key
27	776289A	1	Shaft-Output/Brake
28	784266	1	Collar-Shift
29	786083	1	Sprocket 18teeth
30	786081	1	Chain-Roller #41
31	780105A	2	Bushing-Flanged
32	786082	1	Sprocket 9teeth
33	784267	1	Rod & Fork ASM
34	776134	1	Shaft-Counter
35	778154	1	Gear-Bevel 42teeth
36	778136	1	Gear-Spur 15 Teeth
37	778126A	1	Gear-Spur 20teeth
38	778249	1	Gear-Spur 23 Teeth
39	778127A	1	Gear-Spur 25 Teeth
40	786071	1	Spacer

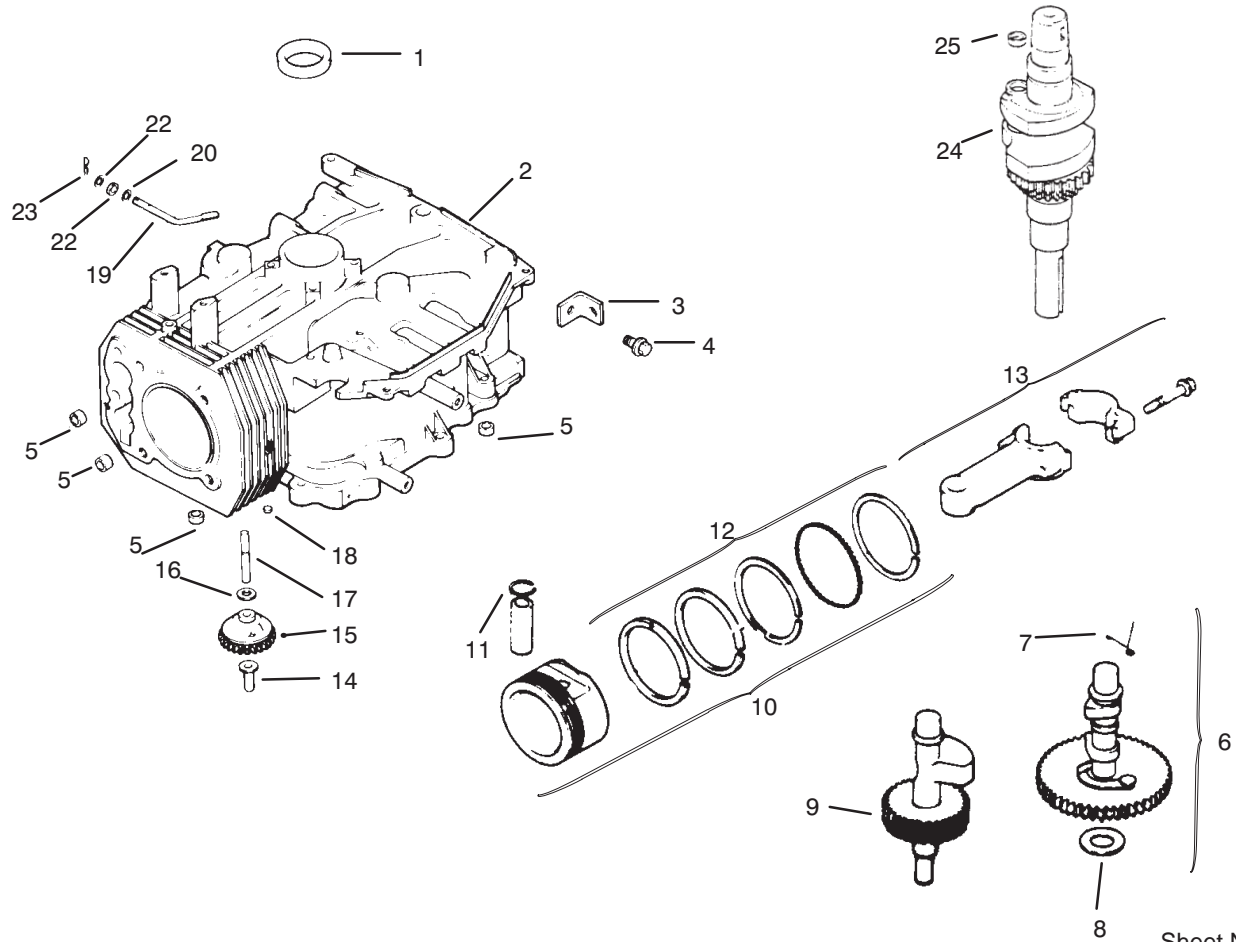

Sheet No.:201

Crankcase

Ref. No.	Part No.	Qty.	Description
1	12 032 03	1	Seal-Crankshaft
2	12 522 21	1	Short Block
3	12 445 02	1	Strap-Lifting
4	M-0839025	1	Screw M8x1.25x22
5	12 380 03	4	Dowel-Locating
6	12 755 49	1	Kit-Camshaft INC 7-8
7	12 089 18	1	Spring-Actuating
8	12 422 07	A/R	Shim-Camshaft A/R
8	12 422 08	1	Shim-Camshaft A/R
8	12 422 09	A/R	Shim-Camshaft A/R
8	12 422 10	A/R	Shim-Camshaft A/R
8	12 422 11	A/R	Shim-Camshaft A/R
8	12 422 12	A/R	Shim-Camshaft A/R
8	12 422 13	A/R	Shim-Camshaft A/R
9	12 144 19	1	Shaft-Balance
10	12 847 01	1	Set Piston w/Ring STD
10	12 847 02	A/R	Set-Piston w/Ring .25
10	12 847 03	A/R	Set-Piston w/Ring .50
11	12 018 02	1	Retainer-Piston Pin
12	12 108 01	1	Ring Set STD
12	12 108 02	A/R	Ring Set .25
12	12 108 03	A/R	Ring Set .50
13	12 067 05	1	Rod Connecting STD
13	12 067 06	A/R	Rod Connecting .25

Ref. No.	Part No.	Qty.	Description
14	12 380 01	1	Pin-Governor Regulating
15	12 043 05	1	Gear-Governor ASM
16	M-0631005	1	Washer-Governor
17	12 144 02	1	Shaft-Governor Gear
18	52 139 09	1	Plug-Cup
19	12 144 01	1	Shaft-Governor Cross
20	X-25-102	1	Washer-Flat
21	12 032 01	1	Seal-Governor Shaft
22	Sm-0631015	1	Washer-Governor Shaft
23	12 380 04	1	Pin-Governor Hitch
24	12 014 29	1	Crankshaft ASM
25	12 139 01	1	Plug-Cup

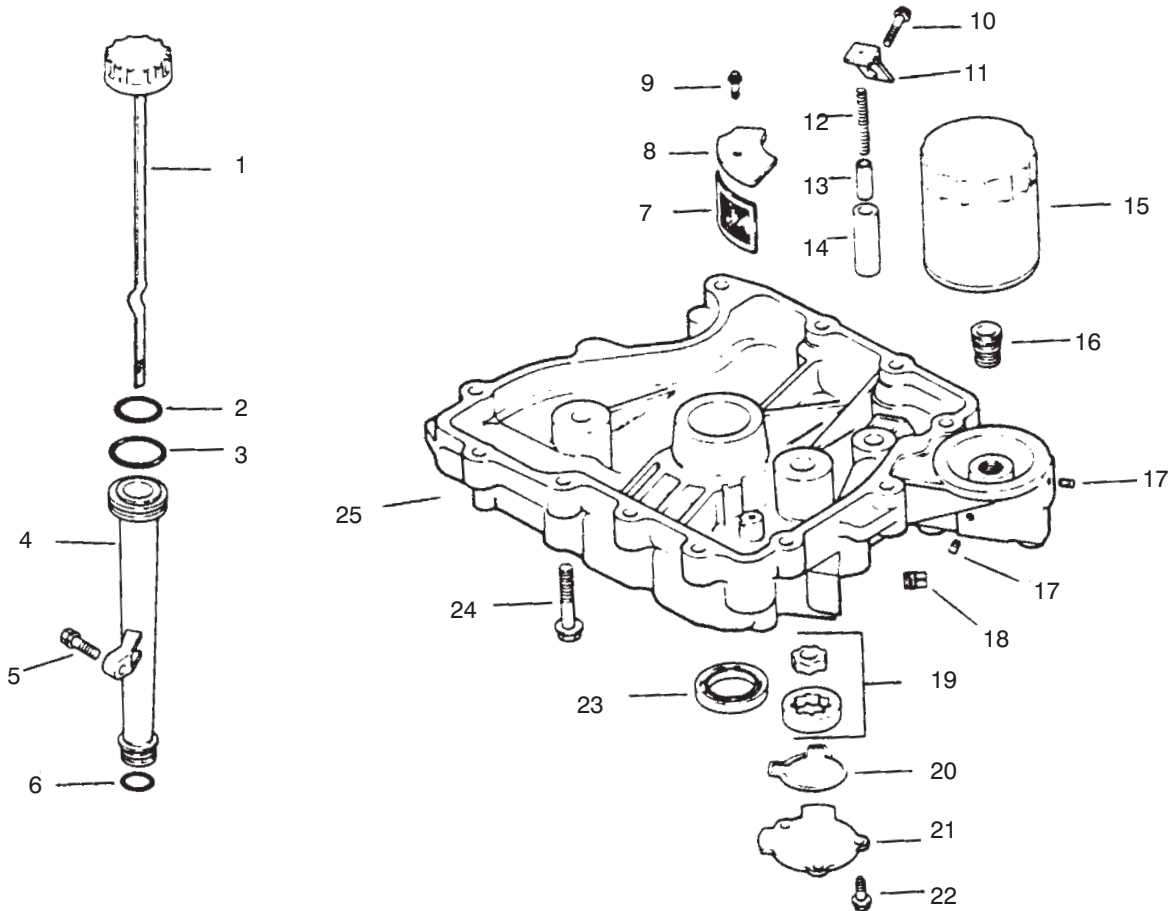

Sheet No.: 202

Oil Pan / Lubrication

Ref. No.	Part No.	Qty.	Description
1	12 038 01	1	Dipstick INC 2-3
2	12 153 03	1	O Ring-Fill Cap
3	12 153 02	1	O Ring-Upper Fill
4	12 123 04	1	Tube-Oil Fill
5	Sm-0545020	1	Screw M5x0.8x20
6	12 153 10	2	O-Ring
7	25 162 07	1	Screen-Oil
8	12 096 03	1	Cover-Oil Pickup Screen
9	Sm-0545016	1	Screw M5x0.8x16
10	M-1039025	1	Screw M10x1.5x25
11	12 126 02	1	Bracket-Oil Pump Relief
12	12 089 03	1	Spring-Oil Relief Valve
13	12 462 01	1	Piston-Oil Relief Valve
14	12 208 01	1	Body-Oil Relief Valve
15	52 050 02	1	Filter-Oil
16	12 136 01	1	Adapter-Oil Filter
17	X-75-1	2	Plug-1/8nptf
18	X-75-10	2	Plug-SH 3/8 NPTF
19	12 393 01	1	Pump-Oil
20	12 032 04	1	O Ring-Oil Pump Cover
21	12 096 02	1	Cover-Oil Pump
22	Sm-0545016	3	Screw M5x0.8x16

Ref. No.	Part No.	Qty.	Description
23	12 032 03	1	Seal-Crankshaft
24	Sm-0839045	11	Screw-Oil Pan
25	12 199 21	1	Pan-Oil
	25 755 13	1	Kit-Oil Cap INC 3

PROTOTYPE

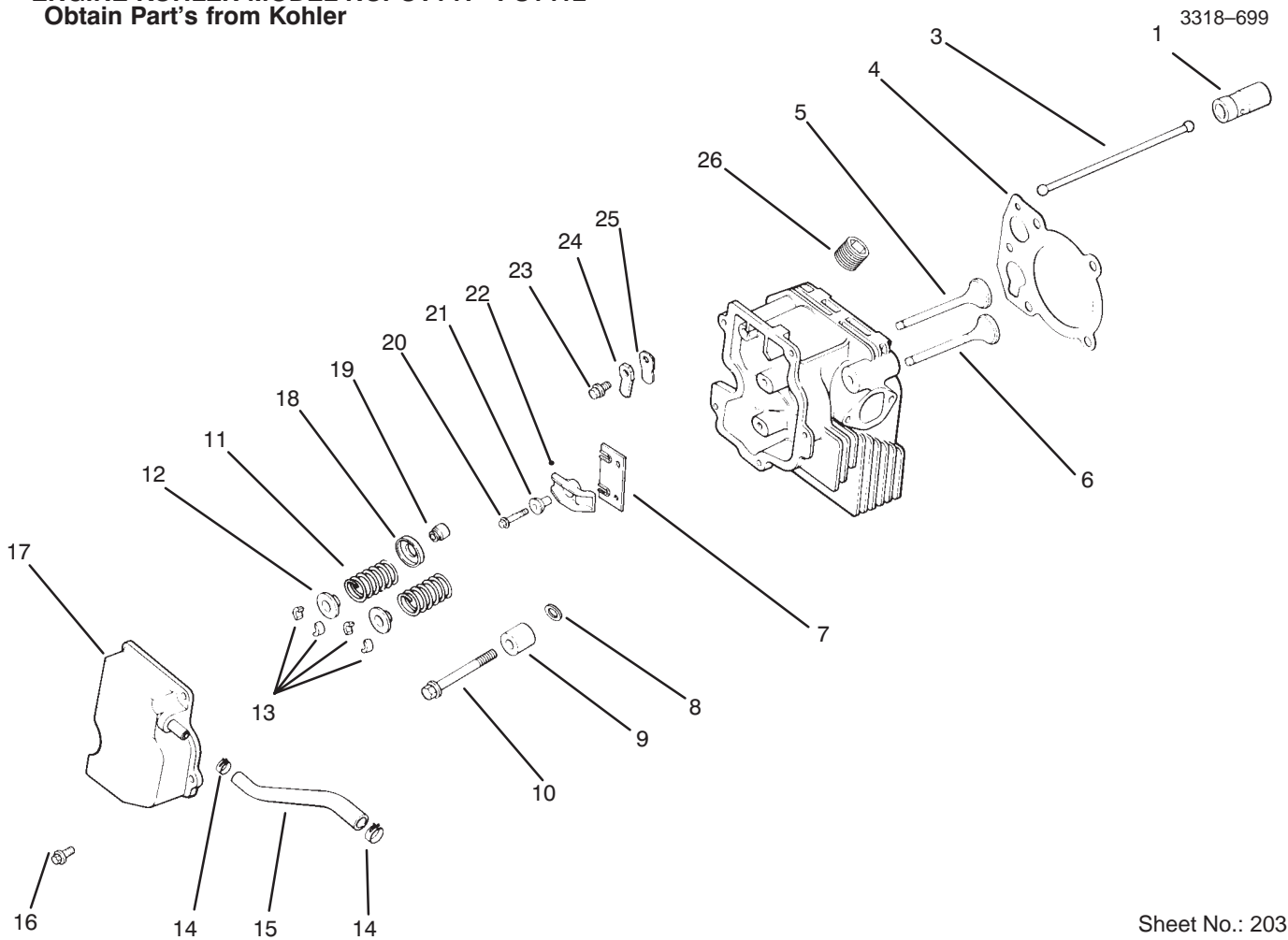

Sheet No.: 203

Cylinder Head, Valve & Breather

Ref. No.	Part No.	Qty.	Description
1	12 351 01	2	Lifter-Valve
3	12 411 01	2	Rod-Push
4	12 041 08	1	Gasket-Cylinder Head
5	12 017 01	1	Valve-Intake STD
5	12 017 02	A/R	Valve-Intake .25
6	12 016 01	1	Valve-Exhaust STD
6	12 016 02	A/R	Valve-Exhaust .25
7	12 146 13	1	Plate-Guide
8	12 468 05	1	Washer-Flat
9	12 112 13	1	Spacer-Head Bolt Exhaust
10	12 086 15	5	Screw M10x1.5x80
11	12 089 01	1	Spring-Valve
12	12 173 01	2	Cap-Valve Spring
13	12 755 03	2	Kit-Retainer
14	X-426-9	2	Clamp-Hose
15	12 326 03	1	Hose-Breather
16	M-0645020	3	Screw-HH M6x1.0x20
17	12 096 07	1	Cover-Valve w/Nipple
18	235011	2	Retainer-Spring
19	24 032 05	1	Seal-Valve Stem
20	M-0640034	2	Screw M6x1.0x34
21	24 194 01	2	Ball-Rocker Pivot
22	24 186 03	2	Arm-Rocker
23	M-0545010	1	Screw M5x0.8x10

Ref. No.	Part No.	Qty.	Description
24	12 018 01	1	Retainer-Breather Reed
25	12 402 02	1	Reed-Breather
26	X-75-23	1	Plug
	12 755 58	1	Kit-Cylinder Head

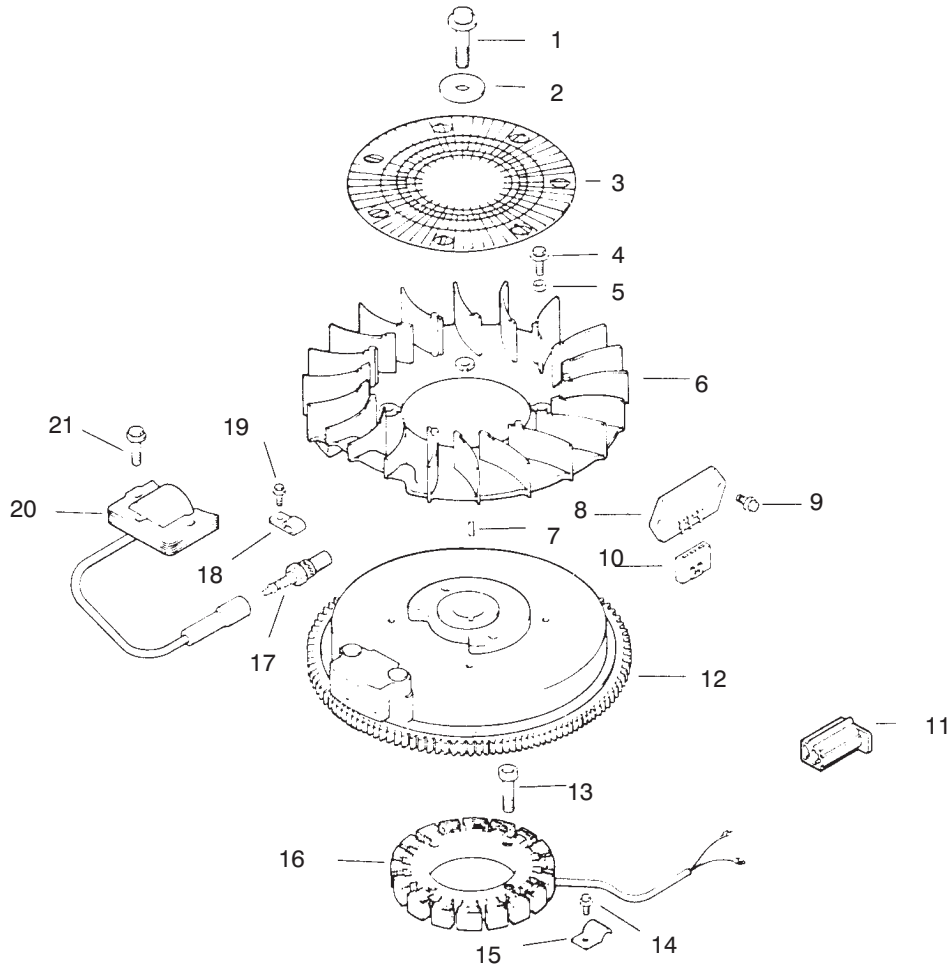

Sheet No.: 204

Ignition / Electrical

Ref. No.	Part No.	Qty.	Description
1	12 086 14	1	Screw-Flywheel Mounting
2	12 486 03	1	Washer-Flat
3	12 162 03	1	Screen-Grass
4	M-0639016	4	Screw M6x1.0x16
5	12 112 01	4	Spacer-Fan
6	12 157 01	1	Fan
7	X-42-15	1	Key
8	12 403 01	1	Rectifier-Unregulated
9	M-0639016	2	Screw M6x1.0x16
10	236602	1	Connector-Regulator
11	41 155 03	1	Connector
12	12 025 16	1	Flywheel ASM
13	M-0548025	4	Screw M5x0.8x25
14	M-0545010	1	Screw M5x0.8x10
15	12 154 02	1	Clip-Stator Harness
16	24 085 01	1	Stator-15 Amp
17	12 132 02	1	Spark Plug
18	X-728-1	1	Clip-Kill Lead
19	M-0545010	1	Screw M5x0.8x10
20	12 584 02	1	Module-Ignition
21	Sm-0545020	2	Screw M5x0.8x20
	12 518 01	1	Lead-White
	25 518 05	1	Lead-Black

Ref. No.	Part No.	Qty.	Description

PROTOTYPE

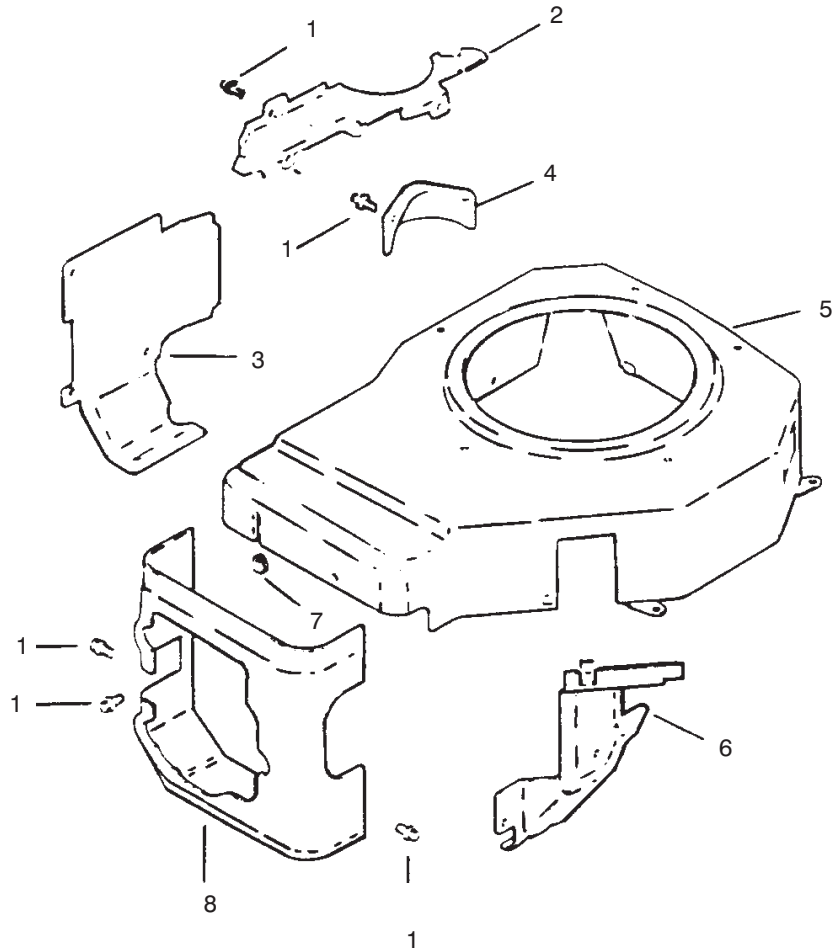

Sheet No.: 205

Blower Housing & Baffles

Ref. No.	Part No.	Qty.	Description
1	M-0545010	15	Screw M5x0.8x10
2	12 146 07	1	Plate-Blower Housing
3	12 063 01	1	Baffle-Cylinder Barrel
4	12 096 23	1	Cover-Starter
5	12 027 11	1	Housing-Blower
6	12 063 05	1	Baffle-Carburetor
7	12 313 03	1	Grommet-Blower Housing
8	12 063 01	1	Baffle-Cylinder Barrel
	12 133 31	1	Decal-Hp.

Ref. No.	Part No.	Qty.	Description

PROTOTYPE

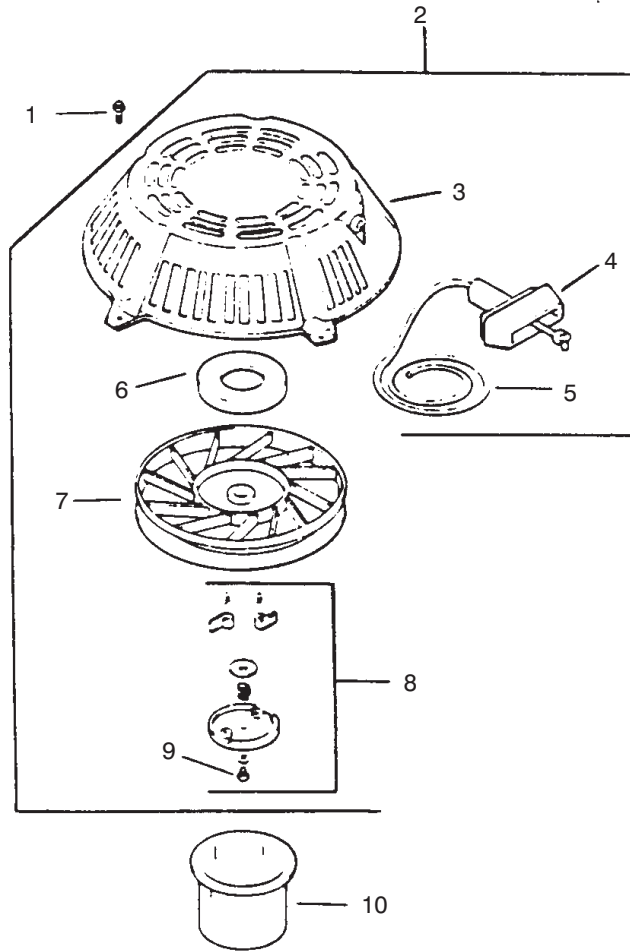

Sheet No.: 206

Starter System

Ref. No.	Part No.	Qty.	Description
1	M-0545010	5	Screw M5x0.8x10
2	12 165 01	1	Starter Incl 3-9
3	12 081 01	1	Housing-Starter
4	234452	1	Handle-Recoil
5	12 160 01	1	Rope-Starter
6	12 089 06	1	Spring & Keeper
7	12 093 01	1	Pulley
8	12 757 06	1	Kit-Dog Replacement
9	41 086 09	1	Screw-Posidrive
10	15 109 01	1	Cup-Driver
	12 113 07	1	Decal-Starting

Ref. No.	Part No.	Qty.	Description

PROTOTYPE

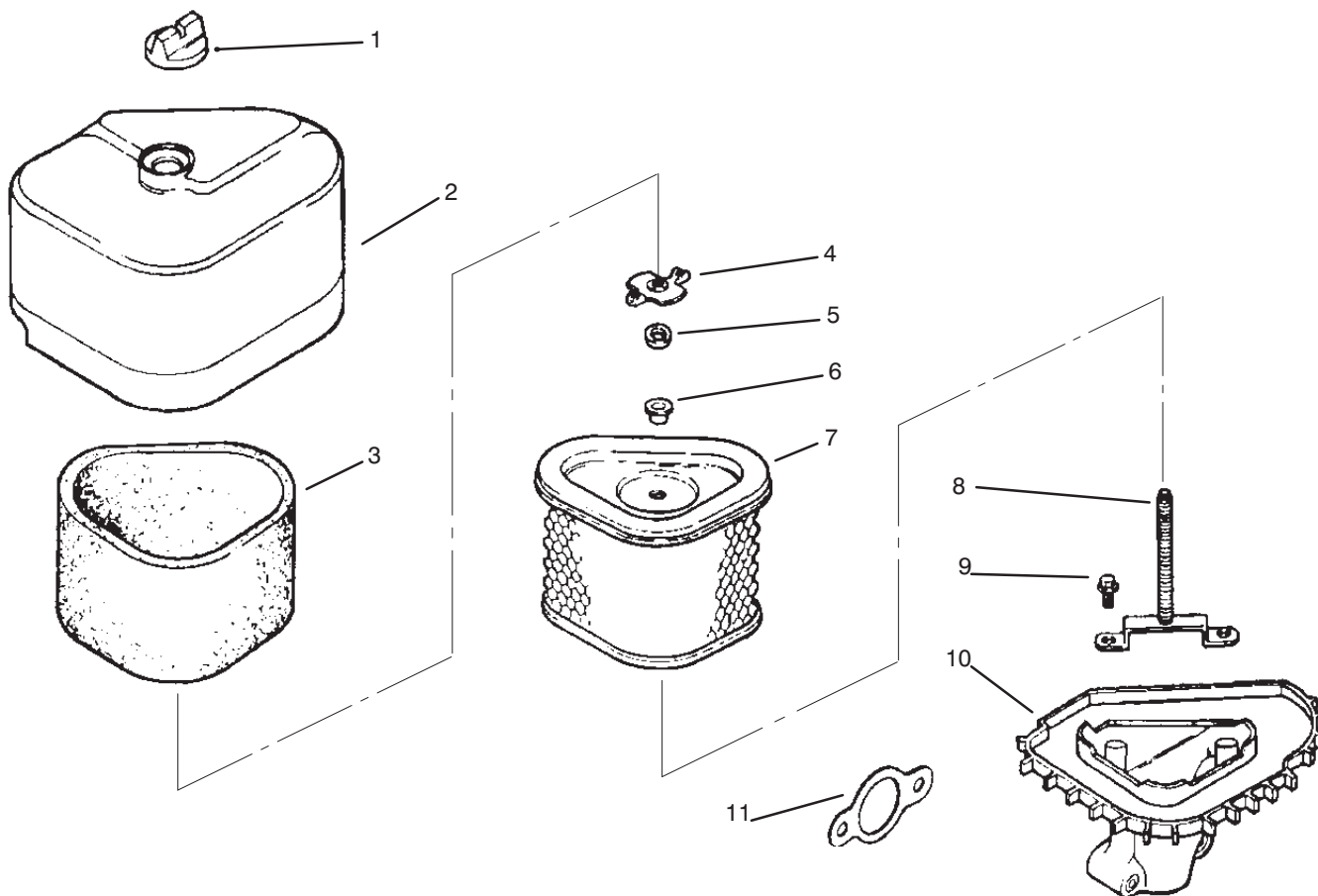

Sheet No.: 207

Air Cleaner

Ref. No.	Part No.	Qty.	Description
1	25 341 02	1	Knob-Cover
2	12 096 16	1	Cover-Air Cleaner
3	12 083 12	1	Precleaner-Element
4	12 100 01	1	Nut-Wing
5	X-25-63	1	Washer-Flat
6	12 313 04	1	Grommet
7	12 083 10	1	Element-Air Cleaner
8	12 072 04	1	Stud-Mounting Plate
9	12 086 01	1	Screw-Mounting Plate
10	12 094 07	1	Base-Air Cleaner
11	12 041 02	1	Gasket-Air Cleaner
	12 113 04	1	Decal-Air Cleaner
	12 743 02	1	Kit-Air Cleaner

Ref. No.	Part No.	Qty.	Description

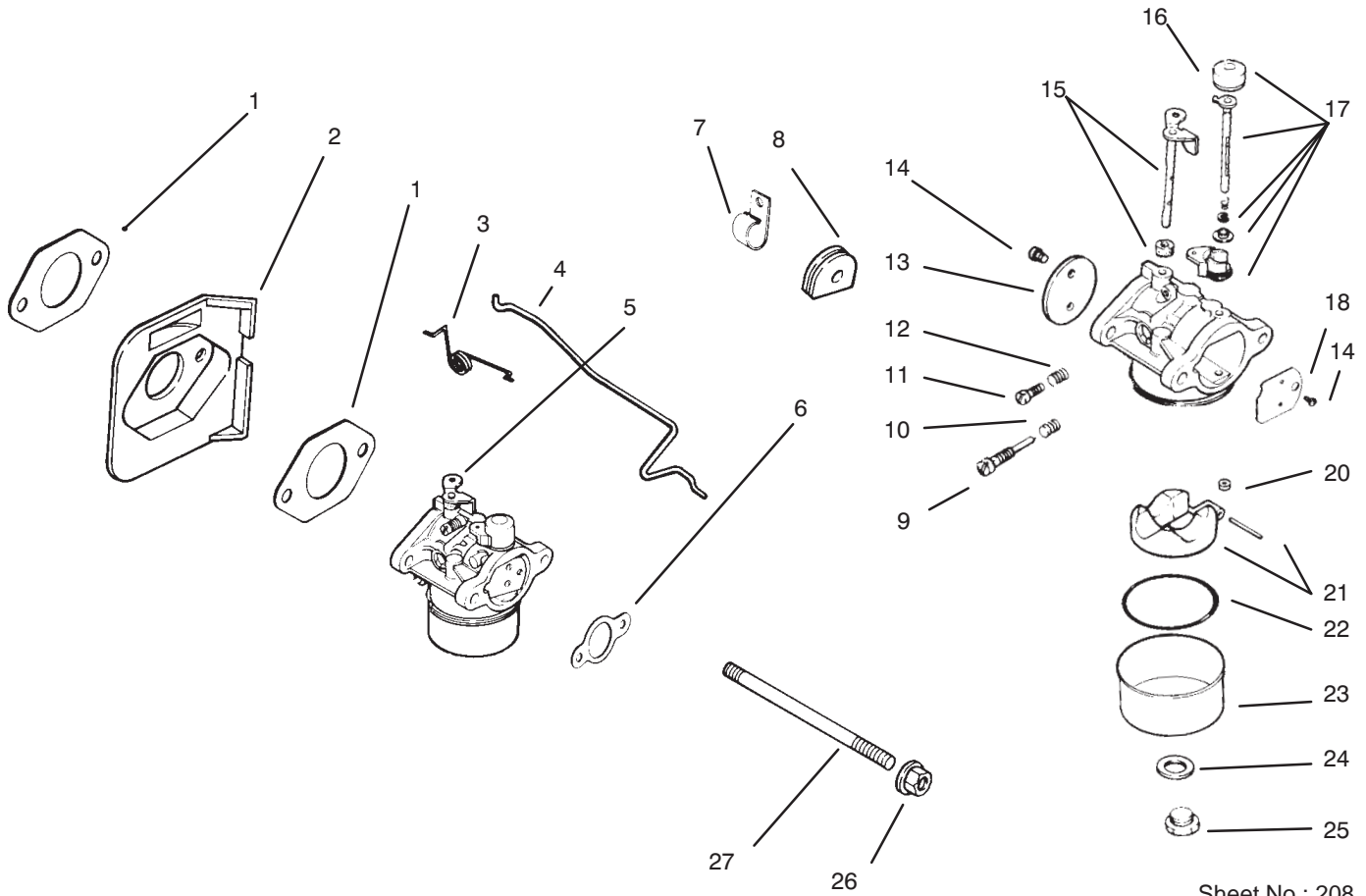

Sheet No.: 208

Carburetor

Ref. No.	Part No.	Qty.	Description
1	12 041 01	1	Gasket-Carburetor
2	12 265 01	1	Deflector-Heat
3	12 089 23	1	Spring-Choke Return
4	12 079 07	1	Linkage-Choke
5	12 053 47	1	Carburetor ASM Incl 9-25
6	12 041 02	1	Gasket-Air Cleaner
7	47 154 01	1	Clip-Cable
8	12 313 01	1	Grommet
9	12 368 05	1	Needle-Idle Fuel Adjust
10	12 089 09	1	Spring-Idle Fuel
11	12 086 04	1	Screw-Idle Speed Adjust
12	12 089 09	1	Spring-Idle Fuel
13	12 146 03	1	Plate-Throttle
14	25 086 27	2	Screw-Throttle Plate
15	12 144 09	1	Shaft-w/Lever & Seal
16	12 173 06	1	Cap-Choke Lever
17	12 757 08	1	Kit-Choke Repair
18	12 146 12	1	Plate-Throttle
20	12 337 07	1	Jet-Main
21	12 757 02	1	Kit-Float
22	12 041 05	1	Gasket-Bowl
23	12 104 01	1	Bowl-Fuel
24	12 041 06	1	Gasket-Bowl Screw

Ref. No.	Part No.	Qty.	Description
25	12 086 05	1	Screw-Fuel Bowl
26	M-0641060	2	Nut M6x1.0
27	M-0629122	2	Stud M6x1.0x110
	12 755 36	1	Kit-High Altitude Jet
	12 757 01	1	Kit-Carburetor Repair
	12 853 47	1	Kit-Carburetor

PROTOTYPE

Toro Part Number Index

Part No.	Page No.	Ref. No.	Qty.	Description
112843	6	16	1	Washer-PTO
608006	6	18	1	Key
7-5461	2	29	1	Spacer-Transmission
10-8110	3	10	A/R	Washer-Thrust
12-3270	6	8	1	Screw-HH
26-9671	2	17	1	"v" Belt
27-6230	2	19	1	Bolt-Wheel
29-5560	5	23	1	Switch-On/Off
44-8310	8	3	2	Ring-Retaining
44-8320	8	10	3	Spring
44-8330	8	6	1	Spacer-Pulley Bearing
44-8340	8	7	1	Collar-Bearing
44-8360	8	4	1	Field Coil & Bearing
47-1970	2	2	1	Grip-Engagement
47-2964	1	35	1	Hose-Gas
47-2982	6	6	1	Hose-Fuel
51-4160	3	14	4	Pulley-Wheel
51-4170	3	13	8	Spacer-Pulley
51-4180	3	15	2	Drum-Brake
51-4190	2	16	1	Pulley-Drive
51-4220	2	12	2	Guard-Coupler
51-4230	3	19	2	Washer-Wheel
51-4240	2	7	1	Shaft-Extension
51-4250	2	8	1	Shaft-Extension
51-4260	2	13	2	Coupler
51-4270	2	5	2	Bearing-Shaft Ext
51-4290	3	12	2	Belt-Drive
51-4370	1	7	1	Spring-Torsion
51-4380	1	8	1	Spring-Torsion
51-4450	1	24	2	Screw-Leveler
51-4540-03	6	13	1	Retainer-Clutch
51-4580	3	1	2	Rod-Brake
51-4600	3	3	1	Brake ASM-RH
51-4610	3	4	1	Brake Arm-LH
51-4650	3	8	2	Link-Brake
51-4660	3	7	2	Plate-Brake Link
51-4700	3	17	2	Band-Brake
51-4850	5	37	1	Lever-Parking Brake
52-2010	5	38	1	Decal-Parking Lever
52-2890	1	11	2	Bushing - Steering Links
54-0230	8	1	1	Field Asm Incl 2/3
54-3200	6	17	1	Clutch ASM
55-3570	1	1	1	ASM-Cap
55-7410	8	5	1	Armature & Pulley ASM
56-6360	6	4	1	Filter-Fuel
57-6360	6	15	1	Screw-HH
57-6380	6	12	4	Screw-HH
62-4540-03	2	22	1	Pulley-Idler
63-7590	5	15	1	Relay
63-8360	5	12	2	Key-Ignition
63-8440	6	29	1	Decal-Hot Surface
65-3090	5	20	1	Decal-Read Manual
66-7400	1	32	1	Plate-Control
67-6370	1	17	1	Bracket-Support
67-6380	1	18	1	Bracket-Support
67-6440	5	9	1	Handle-Upper
68-2190	2	18	1	Spring-Extension
68-9690	1	25	2	Fitting Rod
70-7045	7	12	1	Card-Registration
71-1280	5	34	1	Decal-Warning
72-2190	2	28	1	Mount-Shift Lever
74-0040	1	6	4	Spacer-Pivot

*Not Illustrated

Toro Part Number Index (cont.)

Part No.	Page No.	Ref. No.	Qty.	Description
74-0050	6	19	1	Sheave-Lower
74-0060	6	20	1	Sheave-Upper
74-0220	1	14	1	Idler Bracket LH
74-0230	1	13	1	Idler Bracket RH
74-0320	2	1	1	Lever-Shift
74-0360	1	34	1	Frame-Rear
74-0380	5	6	1	Control Pivot
74-0480	2	11	2	Pulley-Drive ASM
74-0521	1	15	2	Rod-Fitting
74-0610	2	27	1	Transmission
74-0630	5	21	1	Control-Throttle
74-0720	5	29	1	Tube-Manual
74-0930-01	6	14	1	Guard-Pulley
74-0950	6	26	2	Elbow-90 Degree
82-2180-03	5	28	1	Panel-Control
82-2190	5	39	1	Switch-Bail
82-2280	5	7	1	Decal-Reverse
82-2290	5	2	1	Decal-Control Bar
82-2300	5	11	1	Switch
82-3820	5	10	1	Boot-Switch
82-4800	2	21	1	Lever-Idler
82-7631	5	35	2	Rod-Control
82-7680	5	4	1	Bail
82-7690	5	1	1	Bar
82-7730	5	33	1	Decal-Panel Proline
82-7750	1	4	1	Decal-Ground Speed
92-1746	4	4	4	Bearing
93-1156	1	29	1	Frame
93-1187-03	5	16	1	Panel-Bottom
94-9651	7	5	1	Manual-Engine
94-9663	3	9	2	ASM-Wheel & Tire
94-9666	5	17	1	Module
95-2800	1	22	2	Pulley-Idler
95-2801	1	23	2	Spacer-Pulley
95-2802	1	2	1	Tank-Fuel
95-2803	5	25	1	Wire Harness
95-2814	1	33	1	Decal-Fuel Shut-Off
218-461	5	13	1	Nut-HH (F/W Sw)
218-595	5	36	1	Connector-Body
231-117	4	5	2	Tire-15x6
232-27	4	6	2	Valve Stem & Cap Assembly
237-124	1	26	1	Grommet
237-141	5	41	2	Grommet
242-80	4	1	2	Rim
2412-87	6	3	1	Clamp-Cable
2412-98	1	3	2	Clamp-Hose
2412-98	6	5	1	Clamp-Hose
2412-108	6	7	1	Clamp-Hose
2412-120	5	26	2	Clamp-"R"
251-291	8	8	1	Bearing-Pulley
251-292	8	2	1	Bearing
283-6	1	16	2	Pin-Clevis
283-55	5	19	2	Pin-Clevis
288-4	6	28	1	Cap-Pipe
289-51	6	27	1	Nipple-Pipe
302-5	2	14	2	Fitting-Grease
302-11	4	2	2	Fitting-Grease
321-2	5	18	1	Screw-HH
321-4	2	6	4	Screw-HH
322-2	2	24	4	Screw-HH
322-4	1	30	4	Screw-HH
322-7	3	18	8	Screw-HH

PROTOTYPE

*Not Illustrated

Toro Part Number Index (cont.)

Part No.	Page No.	Ref. No.	Qty.	Description
323-6	1	20	6	Screw-HH
323-8	2	20	1	Screw-HH
323-16	1	19	2	Screw-HH
329-10	2	30	1	Screw
3234-11	5	31	4	Screw-HHF
3245-1	2	15	1	Screw-Set
3245-3	2	10	2	Screw-HSH
3253-4	1	31	4	Washer-Lock
3253-4	2	25	4	Washer-Lock
3253-4	3	16	8	Washer-Lock
3253-4	6	11	6	Washer-Lock
3254-5	5	22	1	Washer-Lock(F/W Switch)
3255-7	6	9	1	Washer-Lock
3256-23	1	10	10	Washer-Flat
3256-23	6	10	1	Washer-Flat
3256-78	6	23	2	Washer-Plain
3257-5	2	9	3	Key-Woodruff
3269-8	1	28	2	Rivet
3290-307	1	12	4	Pin-Cotter
3290-307	3	2	2	Pin-Cotter
3290-307	5	40	2	Pin-Cotter
3290-378	5	24	2	Tie-Cable
3290-381	7	1	2	Tie-Cable
3296-2	5	3	5	Nut Lock
3296-5	8	9	3	Nut-Lock
3296-6	2	26	1	Nut-Lock
3296-23	1	21	2	Nut-Lock
3296-29	4	3	8	Nut-Lock
3296-39	1	5	8	Nut-Lock
3296-39	2	23	1	Nut-Lock
3296-42	2	3	4	Nut-Lock
3296-42	5	14	1	Nut-Lock
32103-25	1	9	2	Nut-Wing
32104-76	5	27	4	Screw-Self TAP
32105-1	5	5	1	Screw-HH
32105-14	5	32	4	Screw-HH
32120-64	2	4	3	Ring-Retaining
32128-21	5	30	4	Nut-HF
32144-19	6	2	1	Screw-HH
32151-40	3	5	2	Ring-Retaining
32151-56	3	6	2	Ring-Retaining
32151-72	3	20	4	Ring-Retaining
32151-80	5	8	2	Ring-Push On
32151-91	3	11	2	Ring-Retaining

PROTOTYPE

