



Count on it.

Operator's Manual

42in Bagger

TimeCutter® MX Series Riding Mower

Model No. 79336—Serial No. 312000001 and Up



and **Note** emphasizes general information worthy of special attention.

Introduction

Read this information carefully to learn how to operate and maintain your product properly and to avoid injury and product damage. You are responsible for operating the product properly and safely.

You may contact Toro directly at www.Toro.com for product and accessory information, help finding a dealer, or to register your product.

Whenever you need service, genuine Toro parts, or additional information, contact an Authorized Service Dealer or Toro Customer Service and have the model and serial numbers of your product ready. **Figure 1** identifies the location of the model and serial numbers on the product. Write the numbers in the space provided.

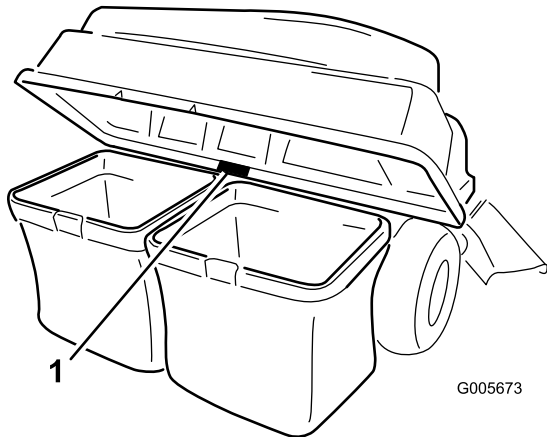

Figure 1

1. Model and serial number location

Model No. _____
Serial No. _____

This manual identifies potential hazards and has safety messages identified by the safety alert symbol (**Figure 2**), which signals a hazard that may cause serious injury or death if you do not follow the recommended precautions.



Figure 2

1. Safety alert symbol

This manual uses 2 other words to highlight information. **Important** calls attention to special mechanical information

Contents

Safety	3
Towing Safety	3
Safety and Instructional Decals	4
Setup	5
1 Installing the Weight	6
2 Installing the Bagger Frame	8
3 Assembling the Bagger Top	9
4 Installing the Bagger Top	10
5 Installing the Chute	11
6 Connecting with the Discharge Tube	13
Operation	14
Emptying the Grass Bags	14
Clearing Obstructions from the Bagger	15
Removing the Bagger	15
Operating Tips	16
Maintenance	17
Recommended Maintenance Schedule(s)	17
Inspecting the Bagger Attachment	17
Inspecting the Mower Blades	17
Caring for the Grass Bags	18
Cleaning the Bagger Attachment	18
Storage	18
Storing the Bagger Attachment	18

Safety

▲ DANGER

Engines can become hot when they are operating. Severe burns can occur from contacting hot surfaces.

Allow engines, especially the muffler, to cool before touching.

▲ DANGER

Debris, such as leaves, grass, or brush can catch fire. A fire in the engine area can cause personal injury and property damage.

- **Keep the engine and muffler area free of debris accumulation.**
- **Take care when opening the bagger cover to keep debris from falling onto the engine and muffler area.**
- **Allow the machine to cool before storing it.**

The following list contains safety information specific to Toro products and other safety information you must know.

- Become familiar with the safe operation of the equipment, with the operator controls, and safety signs.
- Use extra care with grass catchers or other attachments. These can change the operating characteristics and the stability of the machine.
- Follow the manufacturer's recommendations for adding or removing wheel weights or counterweights to improve stability.
- Do not use a grass catcher on steep slopes. A heavy grass catcher could cause loss of control or overturn the machine.
- Slow down and use extra care on hillsides. Be sure to travel in the recommended direction on hillsides. Turf conditions can affect the machine's stability. Use extreme caution while operating near drop-offs.
- Keep all movement on slopes slow and gradual. Do not make sudden changes in speed, directions or turning.
- The grass catcher can obstruct the view to the rear. Use extra care when operating in reverse.
- Use care when loading or unloading the machine into a trailer or truck.
- Never operate with the discharge deflector raised, removed or altered, unless using a grass catcher.
- Keep hands and feet away from moving parts. Do not make adjustments with the engine running.

- Stop on level ground, disengage drives, chock or block wheels, shut off engine before leaving the operator's position for any reason including emptying the grass catcher or unclogging the chute.
- If you remove the grass catcher, be sure to install any discharge deflector or guard that might have been removed to install the grass catcher. Do not operate the mower without either the entire grass catcher or the grass deflector in place.
- Stop the engine before removing the grass catcher or unclogging the chute.
- Do not leave grass in grass catcher for extended periods of time.
- Grass catcher components are subject to wear, damage and deterioration, which could expose moving parts or allow objects to be thrown. Frequently check components and replace with manufacturer's recommended parts, when necessary.

Towing Safety

- Do not attach towed equipment except at the hitch point.
- Follow the attachment manufacturer's recommendation for weight limits for towed equipment and towing on slopes.
- Never allow children or others in or on towed equipment.
- On slopes, the weight of the towed equipment may cause loss of traction and loss of control. Reduce towed weight and slow down.
- Stopping distance increases with the weight of the towed load. Travel slowly and allow extra distance to stop.
- Make wide turns to keep the attachment clear of the machine.
- Do not tow a load that weighs more than the towing machine.

Safety and Instructional Decals



Safety decals and instructions are easily visible to the operator and are located near any area of potential danger. Replace any decal that is damaged or lost.

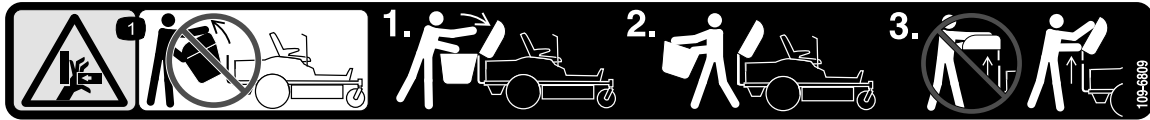

109-6809

1. Crushing hazard of hand—do not remove the whole bagger from the machine; open the bagger top and then remove the bag(s) from the bagger. Do not remove the bagger top when it is closed; open the bagger top and then remove it.



109-7076

Setup

Loose Parts

Use the chart below to verify that all parts have been shipped.

Procedure	Description	Qty.	Use
1	Bolt (3/8 x 1-1/4 inches) Lock nut (3/8 inch) Weight mounting bracket, left Weight mounting bracket, right Washers Weight holding bracket Bolt (3/8 x 1 inch) Flat weight Suitcase weight Keyed cross bar	4 4 1 1 4 1 2 1 1 1	Install the weight.
2	Bagger frame support bracket Support spacer plate Self tapping screw (5/16 x 3/4 inch) Bolt (5/16 x 1 inch) Lock nut (5/16 inch) Angled bracket Carriage bolt (5/16 x 3/4 inch) Bagger frame Clevis pin (1/2 x 2-1/4 inch) Hair pin cotter Rod Washer	1 1 2 2 4 1 2 1 1 5 2 4	Install the bagger frame.
3	Bagger top Bagger screen	1 1	Assemble the bagger top.
4	Grass Bag Upper bagger tube	2 1	Install the bagger top.
5	Chute Knobs Baffle Carriage bolt (5/16 x 1-3/8 inches) Flange nut (5/16 inch) Flat washers (5/16 inch)	1 2 1 2 2 2	Install the chute.
6	No parts required	–	Connect with the discharge tube.

1

Installing the Weight

Parts needed for this procedure:

4	Bolt (3/8 x 1-1/4 inches)
4	Lock nut (3/8 inch)
1	Weight mounting bracket, left
1	Weight mounting bracket, right
4	Washers
1	Weight holding bracket
2	Bolt (3/8 x 1 inch)
1	Flat weight
1	Suitcase weight
1	Keyed cross bar

Procedure

⚠ CAUTION

The bagger changes the weight distribution of the machine. Operating the machine without the front weights may cause an unstable condition which could result in a loss of control.

Ensure the front weights are properly installed before operating the machine with the bagger attachment.

1. Park the machine on a level surface, remove the key from the ignition switch, engage parking brake, let engine cool and disconnect the wire from the spark plug(s) before installing bagger.
2. Locate the forward bolts on the underside of the frame (Figure 3 and Figure 4). Remove the two bolts (3/8 x 1 inch) and two locknuts (3/8 inch). Retain the lock nuts.

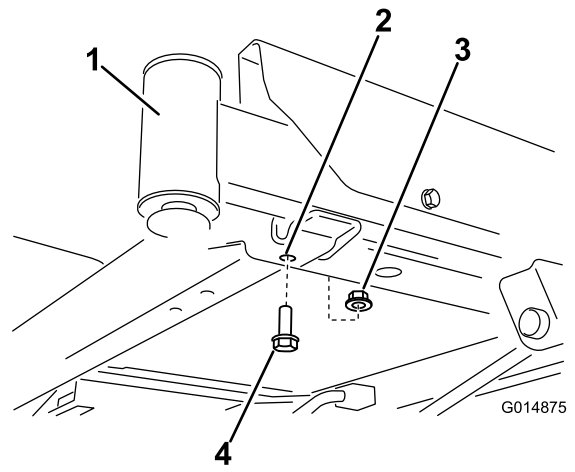

Figure 3

1. Front right caster (caster fork and wheel not shown for clarity)
2. Forward hole, right side
3. Bolt (3/8 x 1 inch)
4. Locknut (3/8 inch)

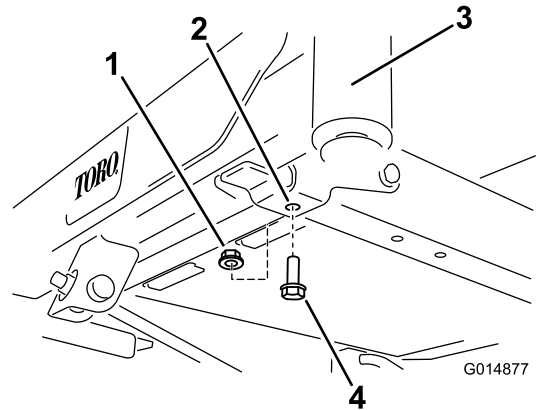

Figure 4

1. Locknut (3/8 inch)
2. Forward hole, left side
3. Front left caster (caster fork and wheel not shown for clarity)
4. Bolt (3/8 x 1 inch)

3. Locate the left and right weight mounting brackets in loose parts. Start by installing the left bracket to the under side of the frame.
4. Secure the bracket to the frame using two bolts (3/8 x 1-1/4 inches), two washers and two lock nuts (3/8 inch) (Figure 5). One locknut is from loose parts and the other is reused from earlier removal.

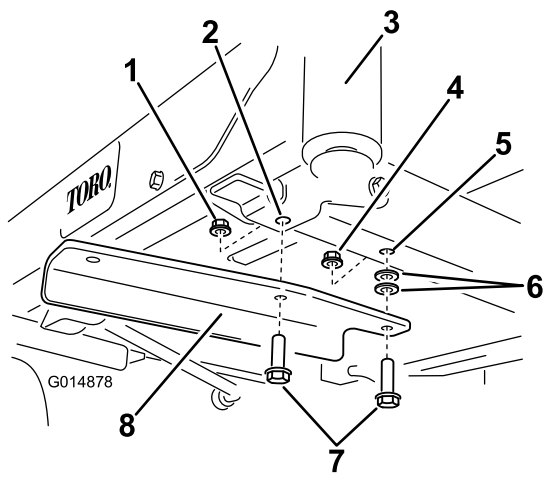

Figure 5

- | | |
|--|--------------------------------|
| 1. Locknut (3/8 inch), existing | 5. Hole, existing in frame |
| 2. Forward hole, left side | 6. Washer |
| 3. Front left caster (castor fork and wheel not shown for clarity) | 7. Bolt (3/8 x 1-1/4 inches) |
| 4. Locknut (3/8 inch), loose parts | 8. Left mounting bracket parts |

the forward fasteners in the foot assist lift pedal bracket. Secure the bracket using two bolts and two lock nuts (Figure 7). One locknut is from loose parts and the other is reused from earlier removal.

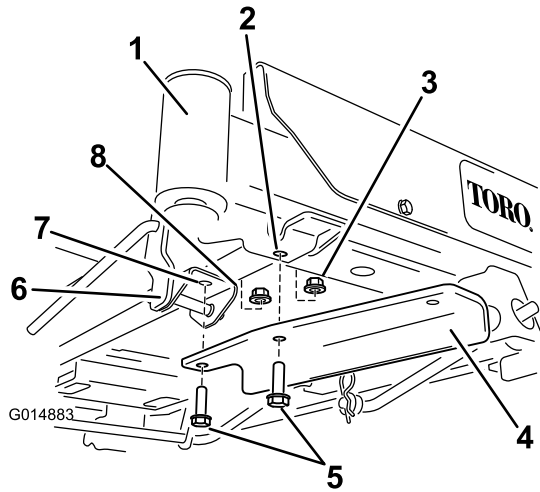

Figure 7

- | | |
|---|------------------------------------|
| 1. Front right caster (castor fork and wheel not shown for clarity) | 5. Bolt (3/8 x 1-1/4 inches) |
| 2. Forward hole, right side | 6. Foot assist lift pedal bracket |
| 3. Locknut (3/8 inch), existing | 7. Hole, existing in bracket |
| 4. Right mounting bracket | 8. Locknut (3/8 inch), loose parts |

5. On the right side of the machine install the right weight mounting bracket.
- For machines without a foot assist lift pedal: secure the bracket using two bolts (3/8 x 1-1/4 inches), two washers and two lock nuts (3/8 inch) (Figure 6). One locknut is from loose parts and the other is reused from earlier removal.

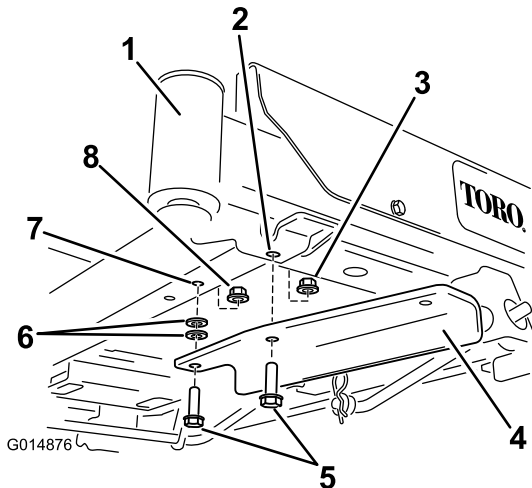

Figure 6

- | | |
|---|------------------------------------|
| 1. Front right caster (castor fork and wheel not shown for clarity) | 5. Bolt (3/8 x 1-1/4 inches) |
| 2. Forward hole, right side | 6. Washer |
| 3. Locknut (3/8 inch), existing | 7. Hole, existing in frame |
| 4. Right mounting bracket | 8. Locknut (3/8 inch), loose parts |

6. Install the weight holding bracket to the mounting brackets (Figure 8). Align the inboard holes in the bracket with the mounting brackets installed previously. Make sure the bracket is centered on the frame. Secure with two bolts (3/8 x 1 inch) and two lock nuts (3/8 inch).

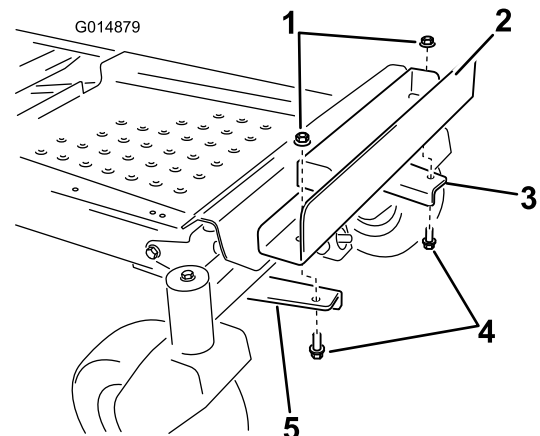

Figure 8

- | | |
|---------------------------|---------------------------|
| 1. Locknut (3/8 inch) | 4. Bolt (3/8 x 1 inch) |
| 2. Weight holding bracket | 5. Right mounting bracket |
| 3. Left mounting bracket | |

- For machines with a foot assist lift pedal: The washers will not be needed. Instead, remove

- Install a flat weight to the holding bracket and move it rearward, flush with the bracket (Figure 9).

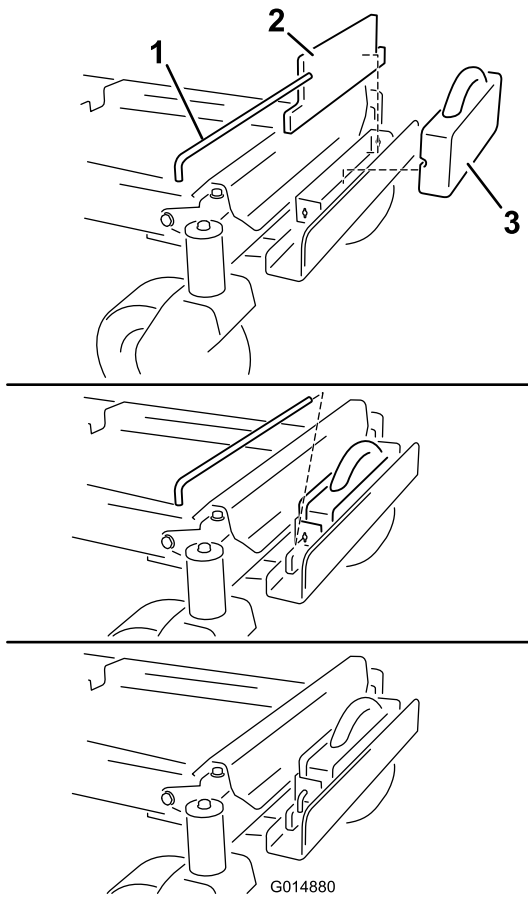

Figure 9

- Flat weight
- Suitcase weight
- Keyed cross bar

- Install a suitcase weight in front of the flat weight (Figure 9). The groove in the suitcase weight should be facing rearward.
- Secure the weights to the bracket with a keyed cross bar (Figure 9). Install the bar and rotate it 90 degrees downward to lock it in place.
- Once all weights and brackets have been installed, go back and check that all fasteners are tight. Tighten as necessary.

Important: Whenever you remove the bagger attachment, remember to remove the front weights to return the proper stability to the machine.

2

Installing the Bagger Frame

Parts needed for this procedure:

1	Bagger frame support bracket
1	Support spacer plate
2	Self tapping screw (5/16 x 3/4 inch)
2	Bolt (5/16 x 1 inch)
4	Lock nut (5/16 inch)
1	Angled bracket
2	Carriage bolt (5/16 x 3/4 inch)
1	Bagger frame
1	Clevis pin (1/2 x 2-1/4 inch)
5	Hair pin cotter
2	Rod
4	Washer

Procedure

- Locate the bagger frame support spacer plate and bracket in loose parts. Install the plate and bracket to the machine frame as shown in Figure 10. Secure the plate and bracket to the frame using two bolts (5/16 x 1 inch) and two lock nuts (5/16 inch).

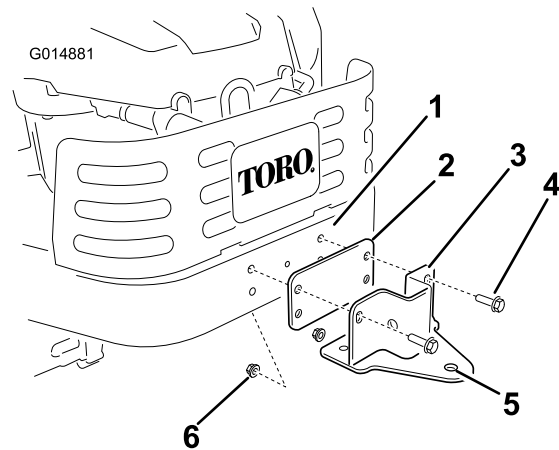

Figure 10

- Machine frame
- Support spacer plate
- Support bracket
- Bolt (5/16 x 1 inch)
- Draw bar hole
- Lock nut (5/16 inch)

- Secure the support bracket to the bottom of the machine frame from below using two self tapping screws (5/16 x 3/4 inch) as shown in Figure 11.

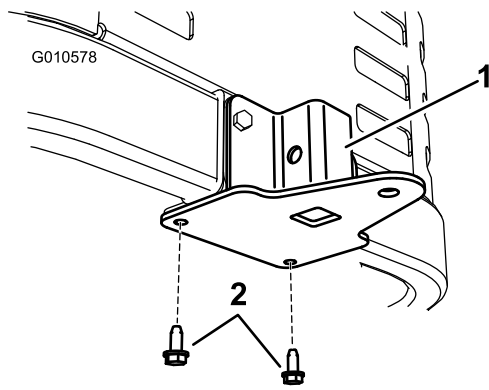

Figure 11

1. Support bracket
2. Self tapping screws (5/16 x 3/4 inch)

3. Install the angled bagger bracket to the engine guard using two carriage bolts (5/16 x 3/4 inch) and two locknuts (5/16 inch).

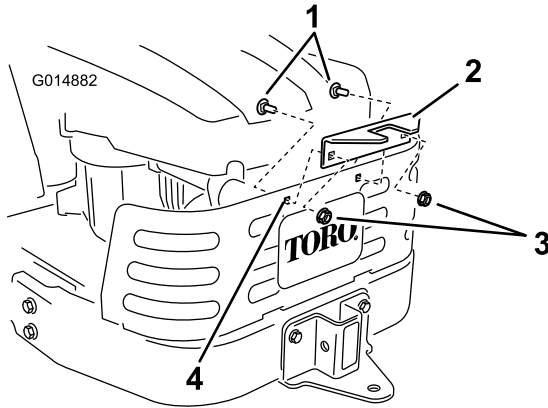

Figure 12

1. Carriage bolt (5/16 x 3/4 inch)
2. Angled bracket
3. Lock nut (5/16 inch)
4. Hole in engine guard, existing

4. Install the bagger frame to the support bracket. Secure the bagger frame with a clevis pin (1/2 x 2-1/4 inch) and hair pin cotter (Figure 13).

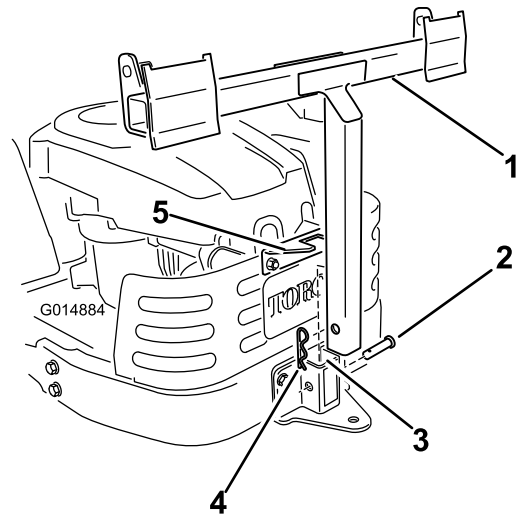

Figure 13

1. Bagger frame
2. Clevis pin (1/2 x 2-1/4 inch)
3. Support bracket, receiver
4. Hair pin
5. Angle bracket

5. Install two support rods, one to each side of the bagger frame. Locate the existing keyed slot in the machine frame and install the bent, flared end of the rod into that slot (Figure 14). Move the rod rearward to seat it in the frame.

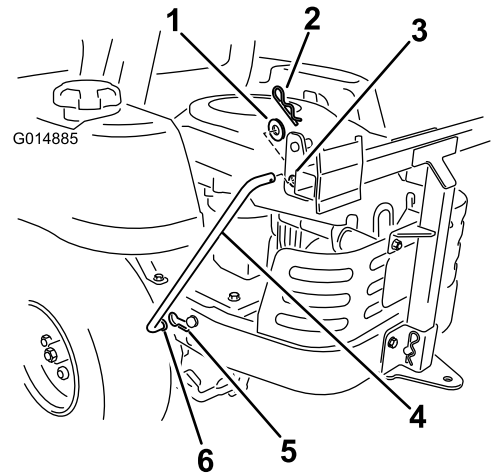

Figure 14

Left side shown

1. Washer
2. Hair pin
3. Bracket frame hole
4. Support rod
5. Keyed slot, existing
6. Bent, flared end of support rod

6. Insert the bent ends of the rod into the bagger frame as shown in Figure 14. Secure the end of the rod with a washer and hair pin.

3

Assembling the Bagger Top

Parts needed for this procedure:

1	Bagger top
1	Bagger screen

Procedure

Turn the bagger top over. Install the screen as shown in [Figure 15](#) so it slopes down toward the collection bags. Make sure the screens snap into place and the tabs engage the bagger top.

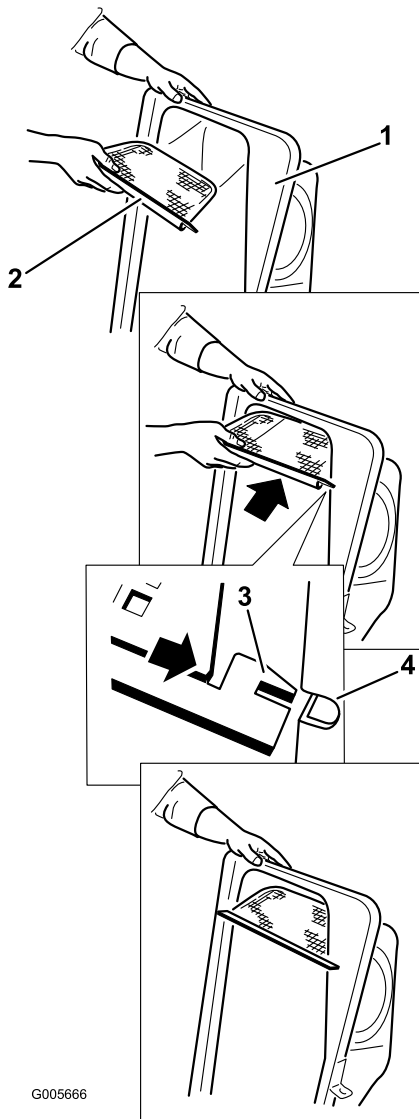

Figure 15

- 1. Bagger top
- 2. Screen
- 3. Screen tab
- 4. Slot in bagger top

4

Installing the Bagger Top

Parts needed for this procedure:

2	Grass Bag
1	Upper bagger tube

Procedure

1. Install the bagger top to the bagger frame. Rotate the bagger top to align the key holes in the bagger top brackets with the keys in the posts on the bagger frame ([Figure 16](#)). Slide the brackets over the posts and rotate the bagger top down to the operating position.

Note: The bagger top is easier to install if two people work together.

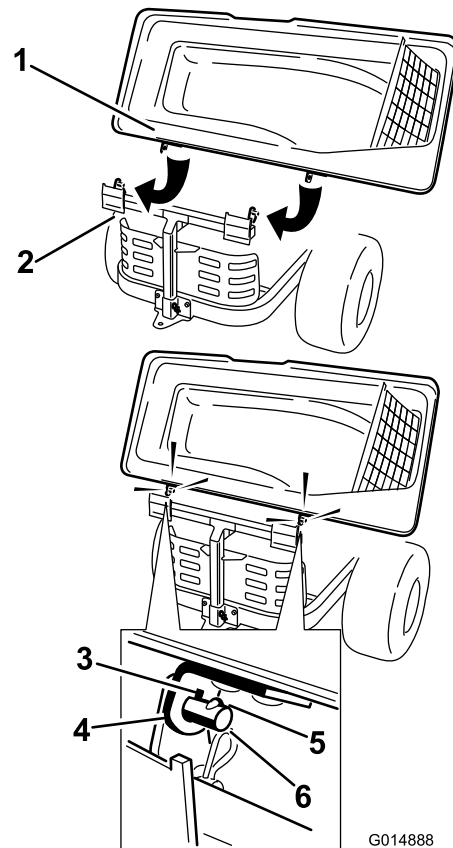

Figure 16

- 1. Bagger top
- 2. Bagger frame
- 3. Key hole
- 4. Bracket, bagger top
- 5. Key
- 6. Post

- Lift the bagger top and install the bags by sliding the bag frame hooks onto the retaining brackets (Figure 17).

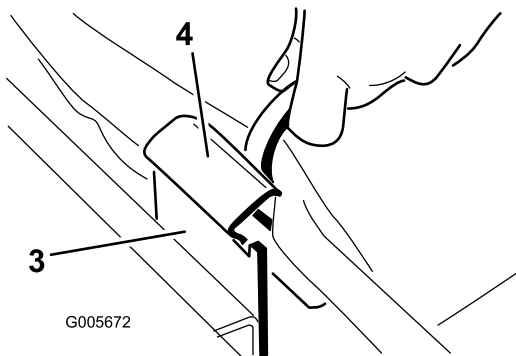
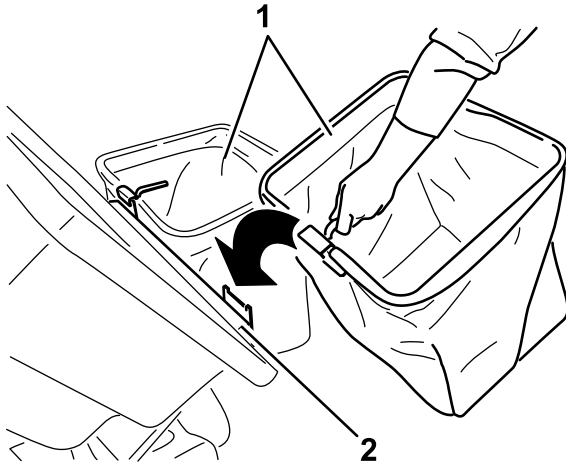

Figure 17

- | | |
|-----------------|----------------------|
| 1. Bag | 3. Retaining bracket |
| 2. Bagger frame | 4. Bag frame hook |

- Lower the bagger top onto the bag (Figure 18).

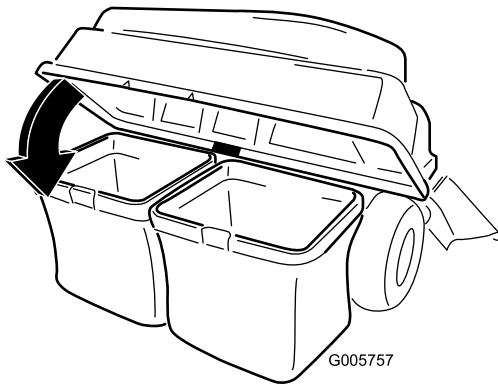

Figure 18

- Install the upper bagger tube. Insert the curved end into the opening in the bagger top. Make sure the flared end with the retention post is pointing down and forward in preparation to be mated with the Finishing Kit.

5

Installing the Chute

Parts needed for this procedure:

1	Chute
2	Knobs
1	Baffle
2	Carriage bolt (5/16 x 1-3/8 inches)
2	Flange nut (5/16 inch)
2	Flat washers (5/16 inch)

Procedure

- Remove the plate assembly that includes the side discharge chute (Figure 19). Save this hardware and assembly.
- Remove the existing baffle under the right side of the mower deck (Figure 19). Save the baffle and hardware.

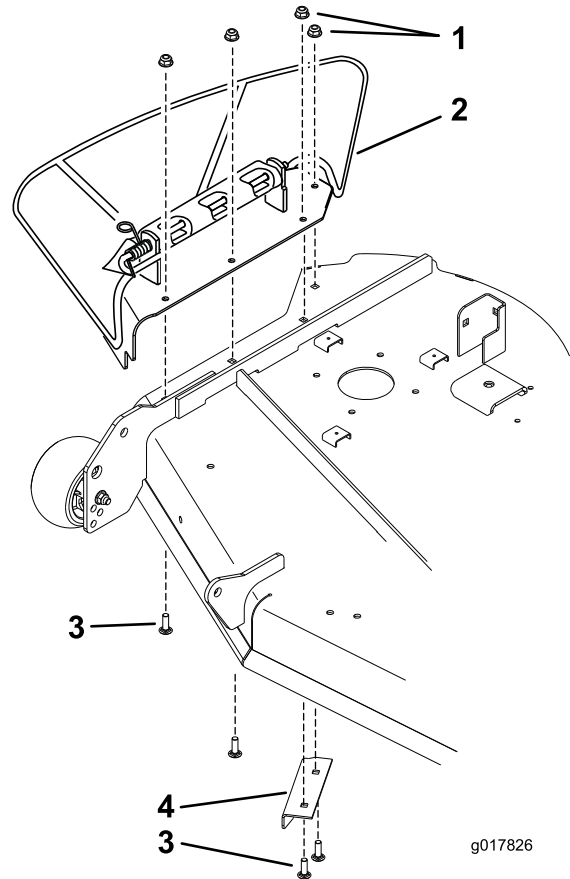

Figure 19

- | | |
|--|--------------------|
| 1. Flange nuts | 3. Carriage bolts |
| 2. Plate assembly with discharge chute | 4. Existing baffle |

- Install the new baffle with a carriage bolt (5/16 x 1 inch) and nut (5/16 inch) from the previously removed baffle (Figure 20). Use a new bolt (5/16 x 1-3/8 inches) and flange nut (5/16 inch) to secure one side of the baffle (Figure 20).

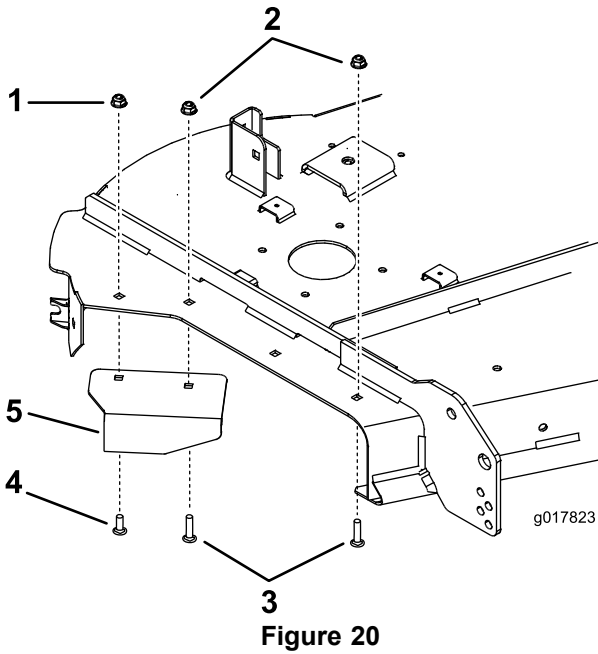

Figure 20

- | | |
|--|---|
| 1. Existing flange nut (5/16 inch) | 4. Existing carriage bolt (5/16 x 1 inch) |
| 2. New flange nut (5/16 inch) | 5. New baffle |
| 3. New carriage bolt (5/16 x 1-3/8 inches) | |

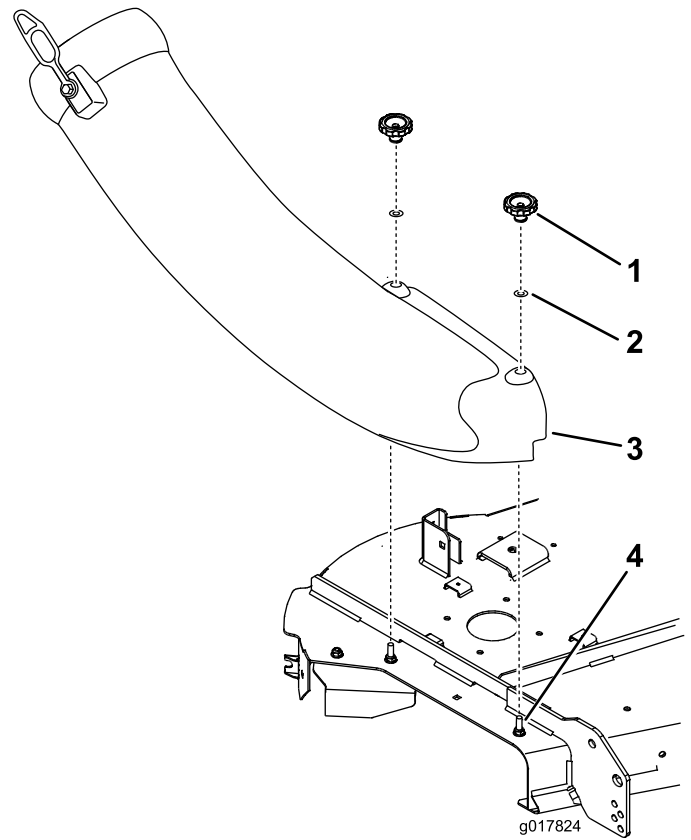

Figure 21

- | | |
|----------------------------|--------------------|
| 1. Knobs | 3. Chute |
| 2. Flat washer (5/16 inch) | 4. Installed bolts |

- Install a carriage bolt and flange nut into the front hole shown in Figure 20.
- Align the holes in the chute and install it onto the bolts. Secure the chute to the mower deck with the two knobs and flat washers (5/16 inch) (Figure 21).

- Hook the flexible latch on the chute to the retaining clasp welded on the mower deck to the rear of the opening (Figure 22).

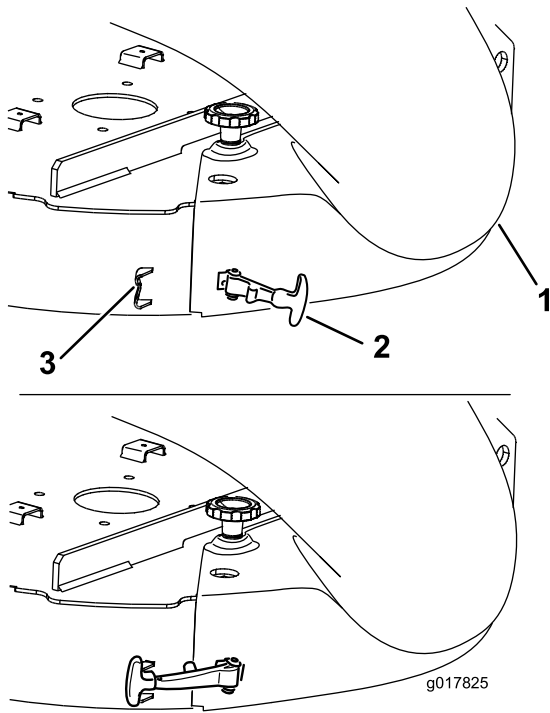

Figure 22

- | | |
|-------------------|---|
| 1. Chute | 3. Retaining clasp (welded to mower deck) |
| 2. Flexible latch | |

6

Connecting with the Discharge Tube

No Parts Required

Procedure

1. Slide the curved end of the discharge tube into the opening in the bagger top (Figure 23).

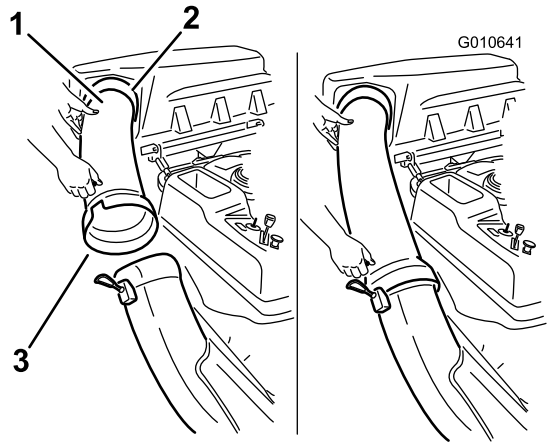

Figure 23

- | | |
|-------------------------------|-----------------|
| 1. Discharge tube, curved end | 4. Peg |
| 2. Opening in bagger top | 5. Rubber strap |
| 3. Discharge tube, flared end | |

2. Slide the flared end of the discharge tube over the end of the chute. Move the rubber retaining strap on

the chute snaps over the peg on the discharge tube to secure it (Figure 23).

3. After the bagger installation, install the wire onto the spark plug(s).

Operation

Note: Determine the left and right sides of the machine from the normal operating position.

⚠ WARNING

To avoid personal injury, follow these procedures:

- Become familiar with all operating and safety instructions in the *Operator's Manual* for the mower before using this attachment.
- Never remove the discharge tube, bags, bagger top, or the chute while the engine is running.
- Always shut the engine off and wait for all moving parts to stop before clearing an obstruction from the bagging system.
- Never do maintenance or repairs while the engine is running.

⚠ WARNING

Without the grass deflector, bagger tubes or complete bagger assembly mounted in place, you and others are exposed to blade contact and thrown debris. Contact with the rotating mower blade(s) and thrown debris will cause injury or death.

- Always install the grass deflector when removing the bagger and changing to side discharge mode.
- If the grass deflector is ever damaged, replace it immediately. The grass deflector routes material down toward the turf.
- Never put your hands or feet under the mower.
- Never try to clear the discharge area or mower blades unless you move the power take off (PTO) to off and rotate the ignition key to off. Also remove the key and pull the wire off of the spark plug(s).
- Turn off the engine before unclogging the discharge chute.

Emptying the Grass Bags

Be careful when lifting or handling a grass bag that is full. To empty the grass bags:

1. Park the machine on a level surface and disengage the blade control switch.
2. Move the motion control levers outward to the neutral lock position, stop the engine, remove the key, set the parking brake and wait for all moving parts to stop before leaving the operating position.
3. Open (raise) the bagger top (Figure 24).

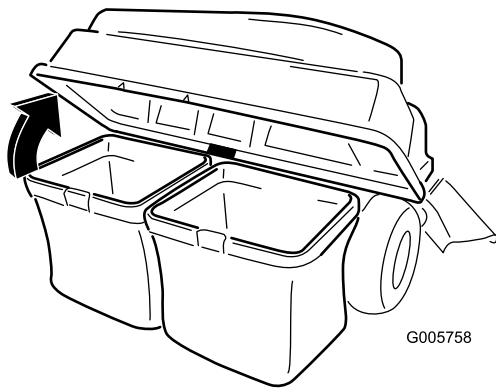

Figure 24

Clearing Obstructions from the Bagger

1. Park the machine on a level surface and disengage the blade control switch.
2. Move the motion control levers outward to the neutral lock position, stop the engine, remove the key, set the parking brake and wait for all moving parts to stop before leaving the operating position.
3. Check the grass bags and empty them if they are full.
4. Remove and separate the discharge tube and chute from the bagger top and mower. Using a stick or similar object, carefully remove and clear the obstruction from the mower, discharge tube, chute, and the bagger top.
5. After you remove the obstruction, install the complete bagger system and resume operation.

4. Compress debris into the bags. With both hands, lift up on the bag and unhook it from the retaining bracket. Empty the bag. Repeat the procedure for the other bag.
5. Install the bags by sliding the bag frame hooks onto the retaining brackets (Figure 25).

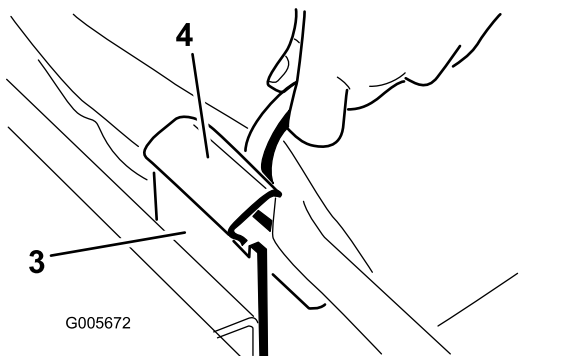
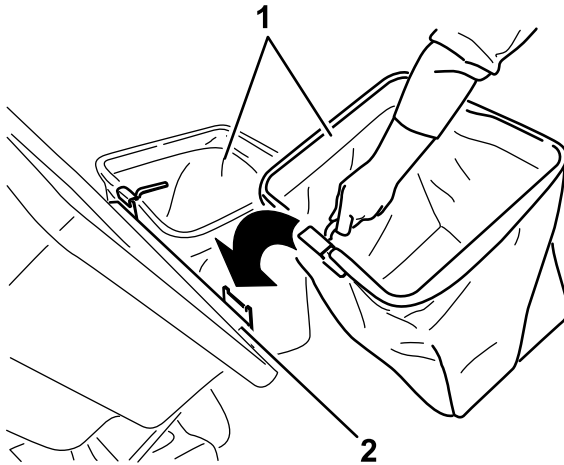

Figure 25

- | | |
|-----------------|----------------------|
| 1. Bag | 3. Retaining bracket |
| 2. Bagger frame | 4. Bag frame hook |

6. Lower the bagger top onto the bags.

Removing the Bagger

CAUTION

Failing to remove the front bagger weights and operating the machine without the bagger attachment may cause an unstable condition which could result in a loss of control.

- Always remove the front weights when removing the bagger attachment.
- Never operate the machine without the bagger attachment and the front weights still installed.

The bagger can be removed by repeating the Setup sections from all installed bagger related kits in reverse order. If weights are installed, always remove the front bagger weights when removing the bagger attachments.

Note: When switching back to side discharge mode, remove the bagging baffle and install the original cutoff baffle that came with the machine.

Operating Tips

Tips for Bagging

Size

Remember that the mower is longer and wider with this attachment installed. By turning too sharply in confined places you may damage the attachment.

Trimming

Always trim with the left side of the mower. Do not trim with the right side of the mower because you could damage the bagger's chute and discharge tube.

Cutting Height

Do not set the mower cutting height too low because long grass surrounding the mower can prevent air from getting under the mower and entering the bagging system. If enough air doesn't get under the mower, the bagging system will plug.

Cutting Frequency

Cut the grass often, especially when it grows rapidly. You will have to cut your grass twice if it gets excessively long.

Cutting Technique

For best lawn appearance, be sure to slightly overlap the mower into the previously cut area. This helps reduce the load on the engine and reduces the chance of plugging the chute and discharge tube.

Bagging Speed

Most often you will bag with the mower throttle in the Fast position and drive at a normal ground speed. However, in extremely dry and dusty grass, you may want to slightly reduce the throttle speed and increase the ground speed of the mower. The bagging system may plug if you drive too fast and the engine speed gets too slow. On hills it may be necessary to slow the mower ground speed. This helps maintain the engine speed and bagging efficiency. Mow downhill whenever possible.

⚠ CAUTION

As the bagger fills, extra weight is added to the back of the machine. If you stop and start suddenly on hills, you may lose steering control or the machine may tip.

- **Do not start or stop suddenly when going uphill or downhill. Avoid uphill starts.**
- **If you do stop the machine when going uphill, disengage the blade control. Then back down the hill using a slow speed.**
- **Do not change speeds or stop on slopes.**
- **Never operate the machine without the bagger attachment and the front weights still installed.**

Bagging Long Grass

Bagging Long Grass Excessively long grass is heavy and may not be propelled completely into the grass bags. If this happens, the discharge tube and chute may plug. To avoid plugging the bagging system, mow the grass at a high height of cut, then lower the mower to your normal cutting height and repeat the bagging process.

Bagging Wet Grass

Always try to cut grass when it is dry because your lawn will have a neat appearance. If you must cut wet grass, use the conventional side discharge feature of the mower. Several hours later, when the clippings are dry, install the complete bagger attachment and vacuum up the grass clippings.

Signs of Plugging

As you are bagging, a small amount of grass clippings normally blow out the front of the mower. An excessive amount of clippings blowing out indicates that the bags are full or the system is plugged.

Maintenance

Note: Determine the left and right sides of the machine from the normal operating position.

Recommended Maintenance Schedule(s)

Maintenance Service Interval	Maintenance Procedure
After the first 10 hours	<ul style="list-style-type: none">• Inspect the bagger
Before each use or daily	<ul style="list-style-type: none">• Clean the bagger
Before storage	<ul style="list-style-type: none">• Inspect the bagger• Clean the bagger

⚠ CAUTION

If you leave the key in the ignition switch, someone could accidentally start the engine and seriously injure you or other bystanders.

Remove the key from the ignition and disconnect the wire from the spark plug before you do any maintenance. Set the wire aside so that it does not accidentally contact the spark plug.

⚠ DANGER

Engines can become hot when they are operating. Severe burns can occur from contacting hot surfaces. Allow engines, especially the muffler, to cool before touching.

⚠ DANGER

Debris, such as leaves, grass, or brush can catch fire. A fire in the engine area can cause personal injury and property damage.

- Keep the engine and muffler area free of debris accumulation.
- Take care when opening the bagger cover to keep debris from falling onto the engine and muffler area.
- Allow the machine to cool before storing it.

Inspecting the Bagger Attachment

Service Interval: After the first 10 hours

Before storage

Inspect the bagger attachment after the first 10 hours of operation, and monthly thereafter.

1. Check the chute, discharge tube, and the bagger top. Replace these parts if they are cracked or broken.
2. Tighten all nuts, bolts, and screws.
3. Inspect all fasteners and latches; replace any missing or damaged.
4. Inspect the grass bags for deterioration.

⚠ WARNING

You or bystanders could be severely injured by flying debris or thrown objects that may pass through torn, worn, or deteriorated grass bags.

- Check the grass bags for holes, rips, wear, and other deterioration.
- Do not wash the grass bags.
- If the bag has deteriorated, install new grass bags supplied by the manufacturer of this bagger attachment.

Inspecting the Mower Blades

Inspect the mower blades regularly and whenever a blade strikes a foreign object.

If the blades are badly worn or damaged, install new blades. Refer to your mower or mower *Operator's Manual* for complete blade maintenance.

Caring for the Grass Bags

Washing the grass bags is not recommended.

To prevent rapid deterioration of the bag material, store the bags where they will dry completely after each use.

Cleaning the Bagger Attachment

Service Interval: Before each use or daily

Before storage

1. After each use, remove and wash the inside and outside of the bagger top, discharge tube, chute, and the underside of the mower, using water sprayed from a garden hose. Use a mild detergent to remove stubborn dirt.
2. Make sure you remove matted grass from all parts.
3. Flush the grass bags with water using garden hose to remove any debris.
4. After washing, let all of the parts dry thoroughly.

Storage

Storing the Bagger Attachment

1. Clean the bagger attachment; refer to Cleaning the Bagger Attachment.
2. Inspect the bagger attachment for damage; refer to Inspecting the Bagger Attachment.
3. Make sure the grass bags are empty and thoroughly dry.
4. Store the bagger in a clean, dry place, out of direct sunlight. This protects the plastic parts and extends the life of the bagger. If you must store the bagger outside, cover it with a weatherproof cover.

Notes:



The Toro Total Coverage Warranty

Limited Warranty (see warranty periods below)

Conditions and Products Covered

The Toro Company and its affiliate, Toro Warranty Company, pursuant to an agreement between them, jointly promise to the original purchaser to repair the Toro Products listed below if defective in materials or workmanship.

The following time periods apply from the date of purchase by the original owner:

Products	Warranty Period
TimeCutter and MX Mowers • Engines ¹ — Residential use	Residential use ² – 3 years Kawasaki – 3 years Kohler – 3 years Toro – 3 years
TimeCutter and MX Mowers • Engines ¹ — Commercial use	Commercial use 30 days Kawasaki – 3 years Kohler – 90 days Toro – 90 days
TITAN Mowers – Residential or Commercial use • Engines ¹ — Residential or Commercial use • Frame	3 years or 240 hours ³ Kawasaki – 3 years Kohler – 2 years Lifetime (original owner only) ⁴
TITAN MX Mowers – Residential or Commercial use • Engines ¹ — Residential or Commercial use • Frame	3 years or 400 hours ³ Kawasaki – 3 years Kohler – 2 years Lifetime (original owner only) ⁴
All Mowers	
• Attachments	1 year
• Battery	90 days Parts and Labor 1 year Parts only
• Belts and Tires	90 days

¹Some engines used on Toro Products are warranted by the engine manufacturer.

²Residential use means use of the product on the same lot as your home. Use at more than one location is considered commercial use and the commercial use warranty would apply.

³Whichever occurs first.

⁴Lifetime Frame Warranty - If the main frame, consisting of the parts welded together to form the tractor structure that other components such as the engine are secured to, cracks or breaks in normal use, it will be repaired or replaced, at Toro's option, under warranty at no cost for parts and labor. Frame failure due to misuse or abuse and failure or repair required due to rust or corrosion are not covered.

This warranty includes the cost of parts and labor, but you must pay transportation costs.

Warranty may be denied if the hour meter is disconnected, altered, or shows signs of being tampered with.

Owner Responsibilities

You must maintain your Toro Product by following the maintenance procedures described in the *Operator's Manual*. Such routine maintenance, whether performed by a dealer or by you, is at your expense.

Instructions for Obtaining Warranty Service

If you think that your Toro Product contains a defect in materials or workmanship, follow this procedure:

1. Contact any Authorized Toro Service Dealer to arrange service at their dealership. To locate a dealer convenient to you, refer to the *Yellow Pages* of your telephone directory (look under "Lawn Mowers") or access our web site at www.Toro.com. You may also call the numbers listed in item #3 to use the 24-hour Toro Dealer locator system.
2. Bring the product and your proof of purchase (sales receipt) to the Service Dealer. The dealer will diagnose the problem and determine if it is covered under warranty.

3. If for any reason you are dissatisfied with the Service Dealer's analysis or with the assistance provided, contact us at:

Customer Care Department, RLC Division
Toro Warranty Company
8111 Lyndale Avenue South
Bloomington, MN 55420-1196
Toll free at 866-216-6029 (U.S. customers)
Toll free at 866-216-6030 (Canadian customers)

Items and Conditions Not Covered

There is no other express warranty except for special emission system coverage and engine warranty coverage on some products. This express warranty does not cover the following:

- Cost of regular maintenance service or parts, such as filters, fuel, lubricants, oil changes, spark plugs, air filters, blade sharpening/worn blade on mowers, cable/linkage adjustments, or brake and clutch adjustments
- Components failing due to normal wear
- Any product or part which has been altered or misused and requires replacement or repair due to accidents or lack of proper maintenance
- Repairs necessary due to improper battery care, failure to use fresh fuel (less than one month old), or failure to properly prepare the unit prior to any period of non-use over one month
- Pickup and delivery charges
- Operational misuse, neglect, or accidents
- Repairs or attempted repairs by anyone other than an Authorized Toro Service Dealer

General Conditions

All repairs covered by these warranties must be performed by an Authorized Toro Service Dealer using Toro approved replacement parts.

Neither The Toro Company nor Toro Warranty Company is liable for indirect, incidental or consequential damages in connection with the use of the Toro Products covered by this warranty, including any cost or expense of providing substitute equipment or service during reasonable periods of malfunction or non-use pending completion of repairs under this warranty.

All implied warranties of merchantability (that the product is fit for ordinary use) and fitness for use (that the product is fit for a particular purpose) are limited to the duration of the express warranty.

Some states do not allow exclusions of incidental or consequential damages, or limitations on how long an implied warranty lasts, so the above exclusions and limitations may not apply to you.

This warranty gives you specific legal rights, and you may also have other rights which vary from state to state.

Countries Other than the United States or Canada

Customers who have purchased Toro products outside the United States or Canada should contact their Toro Distributor (Dealer) to obtain guarantee policies for your country, province, or state. If for any reason you are dissatisfied with your Distributor's service or have difficulty obtaining guarantee information, contact the Toro importer. If all other remedies fail, you may contact us at Toro Warranty Company.