



Count on it.

Operator's Manual

30in Stand-On Aerator

Model No. 23518—Serial No. 312000001 and Up

Model No. 33518—Serial No. 312000001 and Up



WARNING

CALIFORNIA Proposition 65 Warning

The engine exhaust from this product contains chemicals known to the State of California to cause cancer, birth defects, or other reproductive harm.

This spark ignition system complies with Canadian ICES-002.

Important: This engine is not equipped with a spark arrester muffler. It is a violation of California Public Resource Code Section 4442 to use or operate the engine on any forest-covered, brush-covered, or grass-covered land. Other states or federal areas may have similar laws.

The enclosed *Engine Owner's Manual* is supplied for information regarding the US Environmental Protection Agency (EPA) and the California Emission Control Regulation of emission systems, maintenance, and warranty. Replacements may be ordered through the engine manufacturer.

Introduction

This aerator is intended to be used by trained operators in residential and commercial applications. It is primarily designed for aerating areas of well-maintained lawns on residential grounds, parks, sports fields, and on commercial grounds.

Read this information carefully to learn how to operate and maintain your product properly and to avoid injury and product damage. You are responsible for operating the product properly and safely.

You may contact Toro directly at www.Toro.com for product and accessory information, help finding a dealer, or to register your product.

Whenever you need service, genuine Toro parts, or additional information, contact an Authorized Service Dealer or Toro Customer Service and have the model and serial numbers of your product ready. [Figure 1](#) illustrates the location of the model and serial numbers on the product. Write the numbers in the space provided.

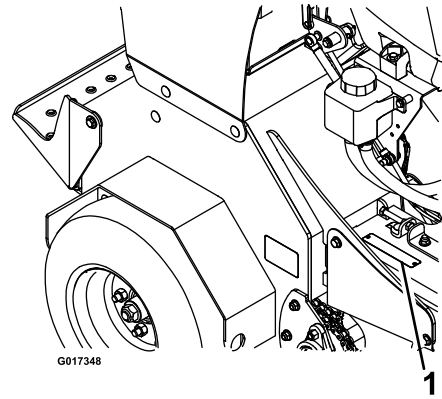

Figure 1

1. Location of the model and serial numbers

Model No. _____

Serial No. _____

This manual identifies potential hazards and has safety messages identified by the safety alert symbol ([Figure 2](#)), which signals a hazard that may cause serious injury or death if you do not follow the recommended precautions.



Figure 2

1. Safety alert symbol

This manual uses 2 other words to highlight information. **Important** calls attention to special mechanical information and **Note** emphasizes general information worthy of special attention.

Contents

Safety	4	Controls System Maintenance	31
Safe Operating Practices	4	Motion Control Linkage Adjustment.....	31
Slope Indicator	8	Hydraulic System Maintenance	32
Safety and Instructional Decals	9	Check Auxiliary Hydraulic Oil Level.....	32
Setup	12	Check Hydraulic Transmission Oil Level.....	32
1 Checking Tire Pressure	12	Change Auxiliary Hydraulic Reservoir Fluid and	
2 Servicing the Battery	12	Filter	32
3 Servicing the Engine	13	Change Hydraulic Transmission Filters and	
4 Servicing the Transmission Hydraulic		Fluid	32
Oil	13	Tire Maintenance	33
5 Servicing the Auxiliary Hydraulic Oil	13	Check Tires.....	33
6 Removing Cylinder Stop (for model		Tire Drive Chain Adjustment	33
33518).....	13	Cleaning	34
Product Overview	15	Clean Engine and Exhaust System Area	34
Controls	15	Remove Engine Shrouds and Clean Cooling	
Specifications	16	Fins	34
Operation	17	Clean Debris From Machine	34
Checking the Engine Oil Level	17	Waste Disposal.....	34
Filling the Fuel Tank with Gasoline	17	Storage	35
Check Safety Interlock System.....	18	Troubleshooting	36
Check for Loose Hardware	18	Schematics	38
Operating Instructions.....	18		
Transporting.....	20		
Maintenance	22		
Recommended Maintenance Schedule(s)	22		
Pre-maintenance Procedures	23		
Lubrication	23		
Lubricate Chains	23		
Lubricate Grease Fittings.....	24		
Lubricate Caster Wheel Hubs.....	24		
Engine Maintenance	25		
Service Air Cleaner	25		
Change Engine Oil	25		
Check Spark Plugs	26		
Check Spark Arrester (if equipped).....	26		
Fuel System Maintenance	26		
Change Fuel Filter	26		
Electrical System Maintenance	27		
Check Battery Charge	27		
Recommended Jump Starting Procedure.....	27		
Drive System Maintenance	28		
Check Tire Pressures.....	28		
Check Condition Of Chains	28		
Check Condition Of Sprockets.....	28		
Wheel Hub Nut and Transmission Output Shaft			
Torque Specification	28		
Jackshaft Drive Chain Tension Adjustment	28		
Drive Wheel Chain Tension Adjustment	29		
Caster Pivot Bearings Pre-Load Adjustment	29		
Brake Maintenance	29		
Adjusting the Parking Brake.....	29		
Adjusting the Brake Switch	29		
Belt Maintenance	30		
Check Condition and Tension of Belts.....	30		
Auxiliary Pump Drive Belt Adjustment.....	30		
Transmission Drive Belt Tension Adjustment.....	30		

Safety

Improper use or maintenance by the operator or owner can result in injury. To reduce the potential for injury, comply with these safety instructions and always pay attention to the safety alert symbol, which means *Caution*, *Warning*, or *Danger*—personal safety instruction. Failure to comply with the instruction may result in personal injury or death.

Safe Operating Practices

The following instructions are adapted from the ANSI B71.4—2004 and B71.8—2004 standard.

Training

- Read the Operator's Manual and other training material. If the operator(s) or mechanic(s) can not read English it is the owner's responsibility to explain this material to them.
- Become familiar with the safe operation of the equipment, operator controls, and safety signs.
- All operators and mechanics should be trained. The owner is responsible for training the users.
- Never let children or untrained people operate or service the equipment. Local regulations may restrict the age of the operator.
- Only adults and mature teenagers should operate an aerator, and even mature teenagers should have adult supervision. Be sure a teenager:
 1. has read and understands the Operator's Manual and recognizes the risks involved;
 2. is sufficiently mature to use caution; and
 3. is of sufficient size and weight to operate the controls comfortably and to manage the aerator without taking risks.
- The owner/user can prevent and is responsible for accidents or injuries occurring to himself or herself, other people or property.

Preparation

- Evaluate the terrain to determine what accessories and attachments are needed to properly and safely perform the job. Only use accessories and attachments approved by Toro.
- Wear appropriate clothing including safety glasses, substantial footwear, long trousers, and hearing protection. Do Not operate when barefoot or when wearing open sandals. Long hair, loose clothing or jewelry may get tangled in moving parts.

⚠ CAUTION

This machine produces sound levels in excess of 85 dBA at the operator's ear and can cause hearing loss through extended periods of exposure.

Wear hearing protection when operating this machine.

- Inspect the area where the equipment is to be used and remove all rocks, toys, sticks, wires, bones, and other foreign objects which can be thrown by the machine and may cause personal injury to the operator or bystanders.

⚠ DANGER

In certain conditions gasoline is extremely flammable and vapors are explosive.

A fire or explosion from gasoline can burn you, others, and cause property damage.

- Fill the fuel tank outdoors on level ground, in an open area, when the engine is cold. Wipe up any gasoline that spills.
- Never refill the fuel tank or drain the machine indoors or inside an enclosed trailer.
- Do Not fill the fuel tank completely full. Fill the fuel tank to the bottom of the filler neck. The empty space in the tank allows gasoline to expand. Overfilling may result in fuel leakage or damage to the engine or emission system.
- Never smoke when handling gasoline, and stay away from an open flame or where gasoline fumes may be ignited by spark.
- Store gasoline in an approved container and keep it out of the reach of children.
- Add fuel before starting the engine. Never remove the cap of the fuel tank or add fuel when engine is running or when the engine is hot.
- If fuel is spilled, Do Not attempt to start the engine. Move away from the area of the spill and avoid creating any source of ignition until fuel vapors have dissipated.
- Do Not operate without entire exhaust system in place and in proper working condition.

⚠ DANGER

In certain conditions during fueling, static electricity can be released causing a spark which can ignite gasoline vapors. A fire or explosion from gasoline can burn you and others and cause property damage.

- Always place gasoline containers on the ground away from your vehicle before filling.
- Do Not fill gasoline containers inside a vehicle or on a truck or trailer bed because interior carpets or plastic truck bed liners may insulate the container and slow the loss of any static charge.
- When practical, remove gas-powered equipment from the truck or trailer and refuel the equipment with its wheels on the ground.
- If this is not possible, then refuel such equipment on a truck or trailer from a portable container, rather than from a gasoline dispenser nozzle.
- If a gasoline dispenser nozzle must be used, keep the nozzle in contact with the rim of the fuel tank or container opening at all times until fueling is complete.

⚠ WARNING

Gasoline is harmful or fatal if swallowed. Long-term exposure to vapors has caused cancer in laboratory animals. Failure to use caution may cause serious injury or illness.

- Avoid prolonged breathing of vapors.
- Keep face away from nozzle and gas tank/container opening.
- Keep away from eyes and skin.
- Never siphon by mouth.
- Check that the operator's presence controls, safety switches, and shields are attached and functioning properly. Do Not operate unless they are functioning properly.

Operation

⚠ WARNING

Operating engine parts, especially the muffler, become extremely hot. Severe burns can occur on contact and debris, such as leaves, grass, brush, etc. can catch fire.

- Allow engine parts, especially the muffler, to cool before touching.
- Remove accumulated debris from muffler and engine area.
- Install and maintain in working order a spark arrester before using equipment on forest-covered, grass-covered, or brush-covered unimproved land.

⚠ WARNING

Engine exhaust contains carbon monoxide, which is an odorless deadly poison that can kill you.

Do Not run engine indoors or in a small confined area where dangerous carbon monoxide fumes can collect.

- Operate only in daylight or good artificial light, keeping away from holes and hidden hazards.
- Be sure all drives are in neutral and parking brake is engaged before starting engine.
- Never operate the machine with damaged guards, shields, or covers. Always have safety shields, guards, switches and other devices in place and in proper working condition.
- Do Not change the engine governor setting or overspeed the engine.
- Park machine on level ground. Stop engine, wait for all moving parts to stop, remove key and engage parking brake:
 - Before checking, cleaning or working on the machine.
 - After striking a foreign object or abnormal vibration occurs (inspect the machine for damage and make repairs before restarting and operating the machine).
 - Before clearing blockages.
 - Whenever you leave the machine.
- Stop engine, wait for all moving parts to stop, and engage parking brake:
 - Before refueling.

▲ WARNING

Hands, feet, hair, clothing, or accessories can become entangled in rotating parts. Contact with the rotating parts can cause traumatic amputation or severe lacerations.

- **Do Not operate the machine without guards, shields, and safety devices in place and working properly.**
- **Keep hands, feet, hair, jewelry, or clothing away from rotating parts.**
- **NEVER** carry passengers. **DO NOT** operate the machine when people, especially children, or pets are in the area.
- Be alert, slow down and use caution when making turns. Look behind and to the side before changing directions.
- Raise the tines, slow down, and use caution when crossing surfaces other than grass and when transporting the machine to and from the work area.
- Do Not operate the machine under the influence of alcohol or drugs.
- Use extreme care when loading or unloading the machine into a trailer or truck.
- Use care when approaching blind corners, shrubs, trees, or other objects that may obscure vision.

Slope Operation

Use **Extreme** when aerating and/or turning on slopes as loss of traction and/or tip-over could occur. The operator is responsible for safe operation on slopes.

▲ DANGER

Operating on wet grass or steep slopes can cause sliding and loss of control. Wheels dropping over edges, ditches, steep banks, or water can cause rollovers, which may result in serious injury, death or drowning.

- **Do Not operate on slopes when grass is wet.**
- **Do Not operate near drop-offs or near water.**
- **Do Not operate on slopes greater than 15 degrees.**
- **Reduce speed and use extreme caution on slopes.**
- **Avoid sudden turns or rapid speed changes.**
- Reduce tine down pressure to prevent the drive tires from raising off the ground and to prevent the front tires from raising off of the ground while aerating uphill.
- Refer to [Figure 3](#) to determine the approximate slope angle of the area to be aerated.

- Remove or mark obstacles such as rocks, tree limbs, etc. from the working area. Tall grass can hide obstacles.
- Watch for ditches, holes, rocks, dips and rises that change the operating angle, as rough terrain could overturn the machine.
- Avoid sudden starts when aerating uphill because the machine may tip backwards. The machine is more stable going uphill with the tines disengaged.
- Be aware that operating on wet grass, across steep slopes or downhill may cause the machine to lose traction. Loss of traction to the drive wheels may result in sliding and a loss of braking and steering.
- Always avoid sudden starting or stopping on a slope.
- Follow the manufacturer's recommendations for wheel weights or counter weights to improve stability.
- Use extreme care with attachments. These can change the stability of the machine and cause loss of control.

Maintenance and Storage

- Raise the tines, set the parking brake, stop engine and remove key or disconnect spark plug wire. Wait for all movement to stop before adjusting, cleaning or repairing.
- Keep engine and engine area free from excessive grease or oil and other debris which can accumulate in these areas. These materials can become combustible and may result in a fire.
- Let engine cool before storing and do not store near flame or any enclosed area where open pilot lights or heat appliances are present.
- Shut off fuel while storing or transporting. Do Not store fuel near flames or drain indoors.
- Park machine on level, hard ground. Never allow untrained personnel to service machine.
- Use jack stands to support components when required.
- Carefully release pressure from components with stored energy.
- Disconnect battery or remove spark plug wire before making any repairs. Disconnect the negative terminal first and the positive last. Reconnect positive first and negative last.
- Use care when checking and servicing tines. Wrap the tine(s) or wear gloves, and use caution when servicing them. Only replace damaged tines. Never straighten or weld them.
- Keep hands and feet away from moving parts. If possible, do not make adjustments with the engine running.
- Charge batteries in an open well ventilated area, away from spark and flames. Unplug charger before connecting or disconnecting from battery. Wear protective clothing and use insulated tools.

⚠ DANGER

Charging or jump starting the battery may produce explosive gases. Battery gases can explode causing serious injury.

- Keep sparks, flames, or cigarettes away from battery.
- Ventilate when charging or using battery in an enclosed space.
- Make sure venting path of battery is always open once battery is filled with acid.
- Always shield eyes and face from battery.

⚠ DANGER

Battery electrolyte contains sulfuric acid, which is poisonous and can cause severe burns. Swallowing electrolyte can be fatal or if it touches skin can cause severe burns.

- Wear safety glasses to shield eyes, and rubber gloves to protect skin and clothing when handling electrolyte.
- Do Not swallow electrolyte.
- In the event of an accident, flush with water and call a doctor immediately.

⚠ CAUTION

If the ignition is in the “ON” position there is potential for sparks and engagement of components. Sparks could cause an explosion or moving parts could accidentally engage causing personal injury.

Be sure ignition switch is in the “OFF” position before charging the battery.

- Keep all guards, shields and all safety devices in place and in safe working condition.
- Check all bolts frequently to maintain proper tightness.
- Frequently check for worn or deteriorating components that could create a hazard.

⚠ WARNING

Removing standard original equipment parts and accessories may alter the warranty, traction, and safety of the machine. Failure to use original Toro parts could cause serious injury or death. Making unauthorized changes to the engine, fuel or venting system, may violate EPA and CARB regulations.

Replace all parts including, but not limited to, tires, belts, tines, and fuel system components with original Toro parts.

⚠ WARNING

Hydraulic fluid escaping under pressure can penetrate skin and cause injury. Fluid accidentally injected into the skin must be surgically removed within a few hours by a doctor familiar with this form of injury or gangrene may result.

- If equipped, make sure all hydraulic fluid hoses and lines are in good condition and all hydraulic connections and fittings are tight before applying pressure to hydraulic system.
- Keep body and hands away from pinhole leaks or nozzles that eject high pressure hydraulic fluid.
- Use cardboard or paper, not your hands, to find hydraulic leaks.
- Before performing any work on the hydraulic system:
 - Safely relieve all pressure in the ground drive hydraulic system by placing the motion control levers in neutral and shutting off the engine.
 - Safely relieve all pressure in the auxiliary hydraulic system by shutting off the engine, turning the ignition switch to the “ON” position, and pressing the tine ground engagement switch. Once the tines have lowered to the ground, release the tine ground engagement switch and turn the ignition switch to the “OFF” position.

Slope Indicator

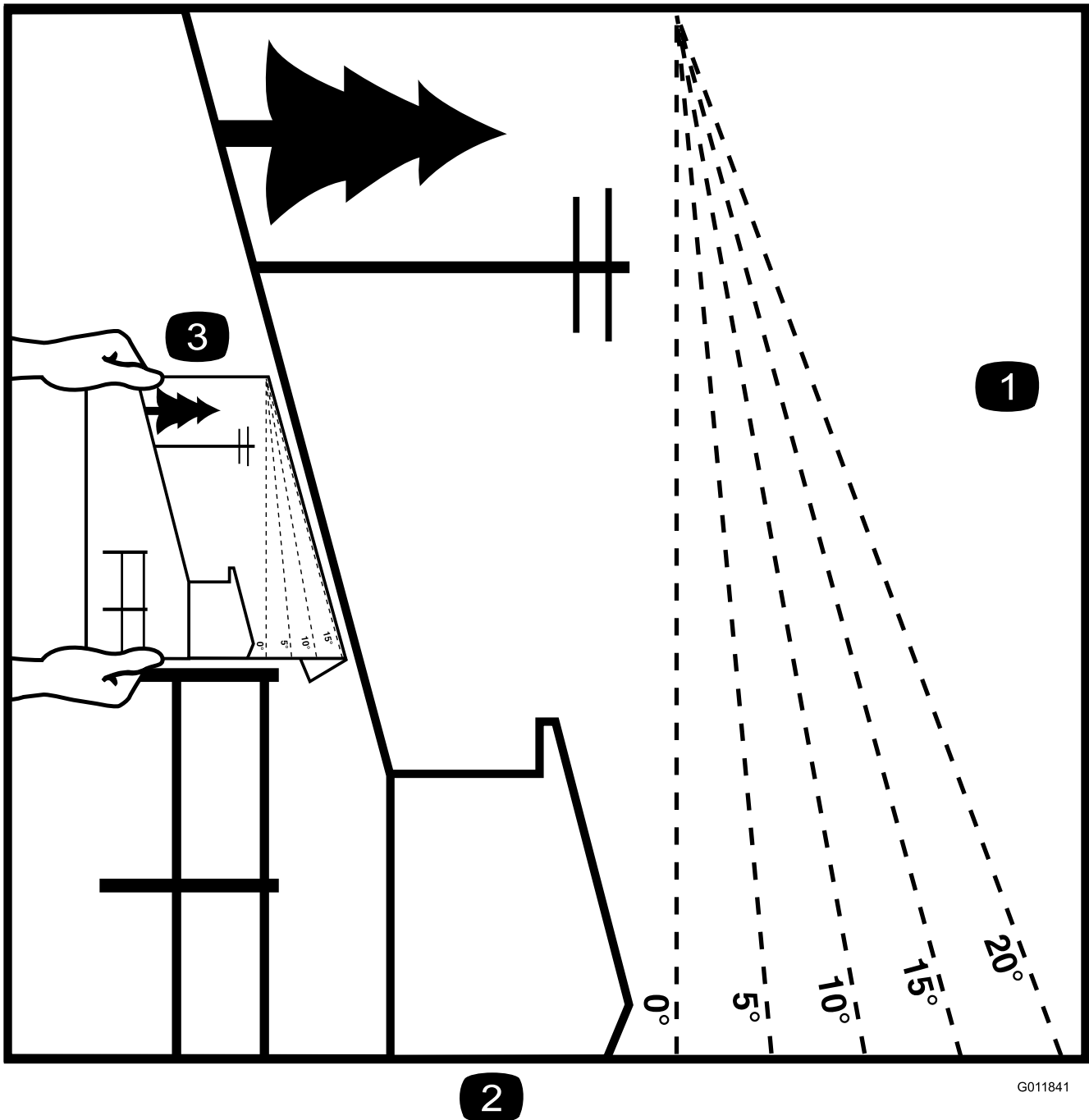

G011841

2

Figure 3

This page may be copied for personal use.

1. The maximum slope you can safely operate the machine on is **15 degrees**. Use the slope chart to determine the degree of slope of hills before operating. **Do not operate this machine on a slope greater than 15 degrees**. Fold along the appropriate line to match the recommended slope.
2. Align this edge with a vertical surface, a tree, building, fence pole, etc.
3. Example of how to compare slope with folded edge.

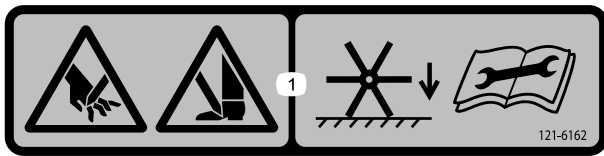

121-6162

1. Cutting/dismemberment hazard of hand or foot, mower blade—lower the tines to the ground; read the *Operator's Manual* for disassembly procedure.

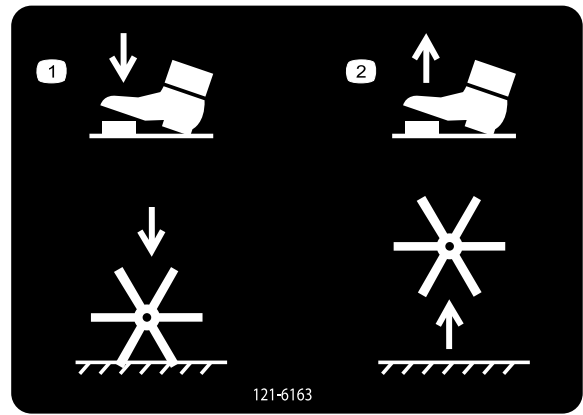

121-6163

1. Press to lower the tines.
2. Release to raise the tines.

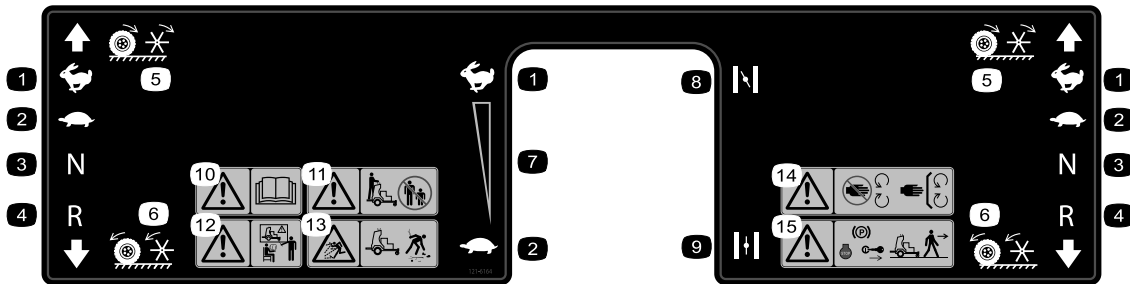

121-6164

- | | | |
|--|---|--|
| 1. Fast | 6. Wheels and tines rotate when moving backward | 11. Warning—keep bystanders a safe distance from the machine. |
| 2. Slow | 7. Continuous variable setting | 12. Warning—do not operate the machine unless you are trained. |
| 3. Neutral | 8. Choke—on | 13. Thrown object hazard—pick up debris before operating the machine. |
| 4. Reverse | 9. Choke—off | 14. Warning—keep away from moving parts; keep all guards in place. |
| 5. Wheels and tines rotate when moving forward | 10. Warning—read the <i>Operator's Manual</i> . | 15. Warning—stop the engine, engage the parking brake, and remove the ignition key before leaving the machine. |

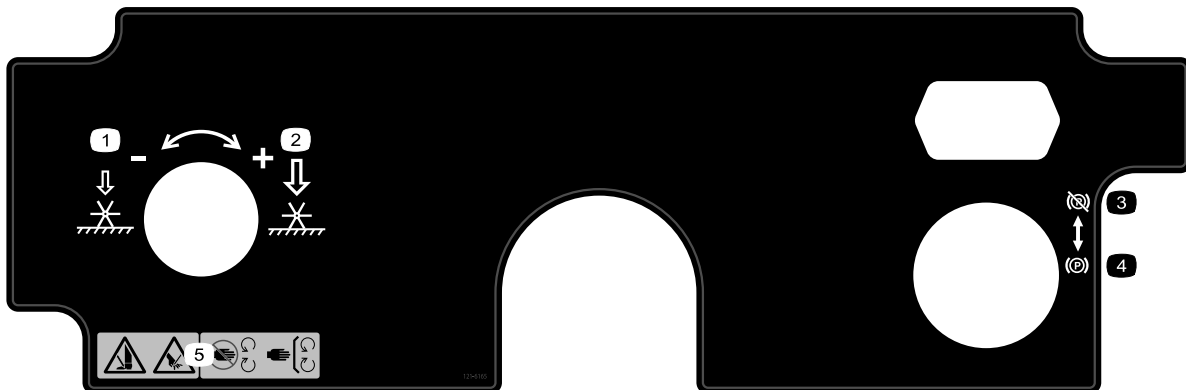

121-6165

- | | |
|---|--|
| 1. Rotate counterclockwise to decrease pressure | 4. Parking brake—engage |
| 2. Rotate clockwise to increase pressure | 5. Cutting/dismemberment hazard of hand or foot, mower blade—stay away from moving parts; keep all guards in place |
| 3. Parking brake—release | |

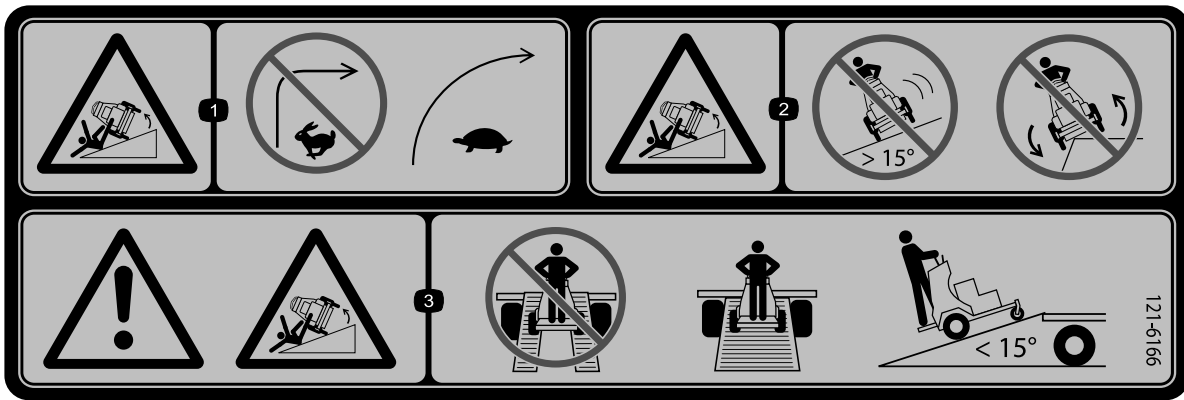

121-6166

1. Tipping hazard—do not turn sharply while travelling fast; slow down and turn gradually.
2. Tipping hazard—do not operate the machine on slopes greater than 15 degrees; do not operate the machine near drop-offs.
3. Warning; tipping hazard—do not use split ramps; use full width ramps to load a unit for transport; use a loading ramp at a maximum of 15 degrees.

Setup

Media and Additional Parts

Description	Qty.	Use
Manual, Operator's	1	Read before operating the machine.
Key	2	Start the machine.

1

Checking Tire Pressure

No Parts Required

Procedure

1. Check the tire pressure in the drive tires. Proper inflation for drive tires is 12–14 psi (83–97 kPa).
2. Adjust if necessary.

2

Servicing the Battery

No Parts Required

Procedure

WARNING

CALIFORNIA Proposition 65 Warning

Battery posts, terminals, and related accessories contain lead and lead compounds, chemicals known to the State of California to cause cancer and reproductive harm.
Wash hands after handling.

Note: The machine is shipped with a filled lead acid battery.

⚠ DANGER

Charging or jump starting the battery may produce explosive gases. Battery gases can explode causing serious injury.

- Keep sparks, flames, or cigarettes away from battery.
- Ventilate when charging or using battery in an enclosed space.
- Make sure venting path of battery is always open once battery is filled with acid.
- Always shield eyes and face from battery.

⚠ DANGER

Battery electrolyte contains sulfuric acid, which is poisonous and can cause severe burns. Swallowing electrolyte can be fatal or if it touches skin can cause severe burns.

- Wear safety glasses to shield eyes, and rubber gloves to protect skin and clothing when handling electrolyte.
- Do Not swallow electrolyte.
- In the event of an accident, flush with water and call a doctor immediately.

1. Check the voltage of the battery with a digital voltmeter. Locate the voltage reading of the battery in the table below and charge the battery for the recommended time interval to bring the charge up to a full charge of 12.6 volts or greater.

Important: Make sure the negative battery cable is disconnected and the battery charger used for charging the battery has an output of 16 volts and 7 amps or less to avoid damaging the battery (refer to [Check Battery Charge \(page 27\)](#) for recommended charger settings).

⚠ CAUTION

If the ignition is in the “ON” position there is potential for sparks and engagement of components. Sparks could cause an explosion or moving parts could accidentally engage causing personal injury.

Be sure ignition switch is in the “OFF” position before charging the battery.

2. Connect the negative battery cable.

Note: If the positive cable is also disconnected, connect the **positive (red) cable** to the positive battery terminal **first**, then the negative (black) cable to the negative battery terminal. Slip insulator boot over the positive terminal.

Note: If time does not permit charging the battery, or if charging equipment is not available, connect the negative battery cables and run the vehicle continuously for 20 to 30 minutes to sufficiently charge the battery.

3

Servicing the Engine

No Parts Required

Procedure

The engine is shipped with oil; check oil level and if necessary fill to the appropriate level. Refer to [Checking the Engine Oil Level](#) (page 17) for instructions and oil specifications..

4

Servicing the Transmission Hydraulic Oil

No Parts Required

Procedure

The machine is shipped with hydraulic oil in the reservoir.

1. Run the machine for approximately 15 minutes to allow any extra air to purge out of the hydraulic system.
2. With the unit cold, check the expansion tank and if necessary add Toro Hypr-oil 500 hydraulic oil to the Full Cold line.
3. Replace hydraulic reservoir cap and tighten until snug. **Do not overtighten.**

5

Servicing the Auxiliary Hydraulic Oil

No Parts Required

Procedure

The machine is shipped with hydraulic oil in the reservoir.

1. Run the machine for approximately 15 minutes to allow any extra air to purge out of the hydraulic system.
2. Completely raise and lower tines three times to purge the air.
3. Loosen the 4 bolts inside the frame securing the rear pad to the unit. Lift the pad up and back to remove it (Figure 4).

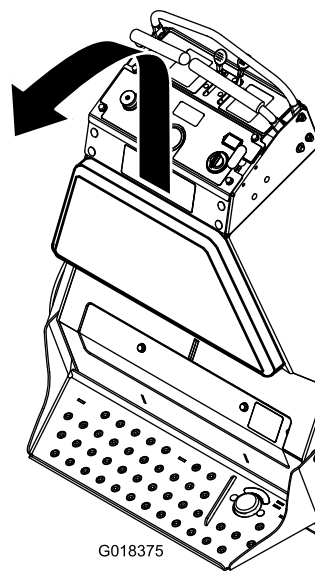

Figure 4

4. Check hydraulic reservoir and if necessary fill the reservoir to the appropriate level with AW-32 hydro oil.
5. Replace hydraulic reservoir cap and tighten until snug. **Do Not overtighten.**
6. Install the previously removed rear pad and tighten the 4 bolts securing it to the frame.

Note: The baffle is labeled “HOT” and “COLD”. The oil level varies with the temperature of the oil. The “HOT” level shows the level of oil when it is at 225°F (107°C). The “COLD” level shows the level of the oil when it is at 75°F (24°C). Fill to the appropriate level depending upon the temperature of the oil. For example: If the oil is about 150° F (65°C). Fill to halfway between the “HOT” and “COLD” levels. If the oil is at room temperature (about 75° F (24°C)), fill only to the “COLD” level.

6

Removing Cylinder Stop (for model 33518)

No Parts Required

Procedure

Note: The tines must be in the raised position before removing the cylinder stop. Running the engine will charge the hydraulic system and raise the tines.

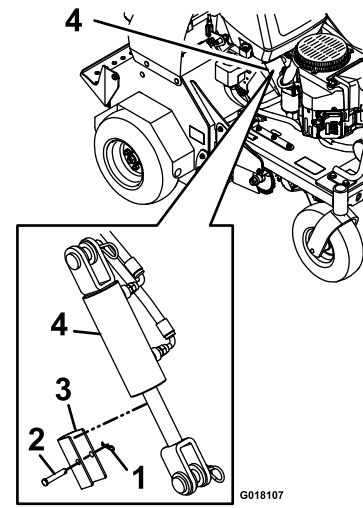

Figure 5

- | | |
|---------------|------------------|
| 1. Hairpin | 3. Cylinder stop |
| 2. Clevis pin | 4. Cylinder |

1. Add a small amount of fuel to the fuel tank. See [Filling the Fuel Tank with Gasoline \(page 17\)](#).
2. Open the fuel shut-off valve by aligning it with the fuel line.
3. Leave the motion control levers in neutral and engage the parking brake.
4. Place the throttle midway between the Slow and Fast positions.
5. Push the choke lever forward into the On position.
6. Turn ignition switch to the Start position. Release the switch as soon as the engine starts.

Important: Do not crank the engine continuously for more than ten seconds at a time. If the engine does not start, allow a 60 second cool-down period between starting attempts. Failure to follow these guidelines can burn out the starter motor.

7. Gradually return the choke to the Off position as the engine warms up. Allow the engine to run an additional 30 seconds, then turn the ignition switch to the Off position to stop the engine.
8. Remove the key and pull the wires off of the spark plugs. Push the wires aside so they do not accidentally contact the spark plugs.
9. Remove and retain the hairpin, clevis pin, and cylinder stop as shown in [Figure 5](#).

10. Replace the spark plug wires.

Product Overview

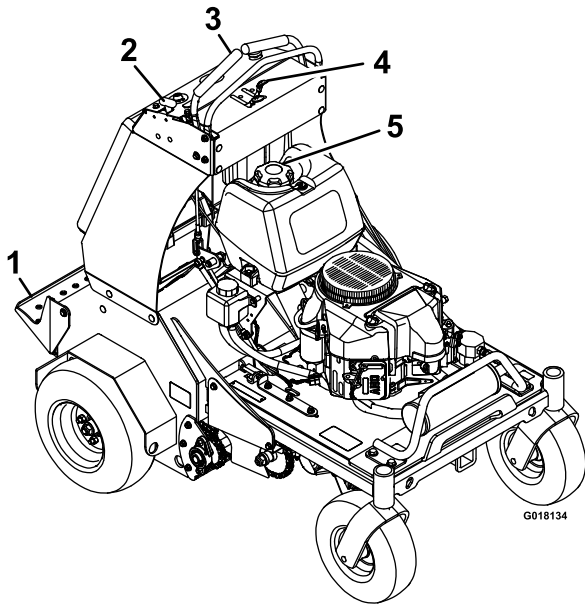

Figure 6

- | | |
|--------------------------|--------------------|
| 1. Platform | 4. Engine controls |
| 2. Parking brake knob | 5. Fuel cap |
| 3. Motion control levers | |

Controls

Motion Control Levers

The motion control levers, located on each side of the top console, control the forward and reverse motion of the machine.

Moving the levers forward or backward turns the wheel on the same side forward or reverse respectively. Wheel speed is proportional to the amount the lever is moved.

Important: The tines are rotating when the motion control levers are moved out of the neutral position.

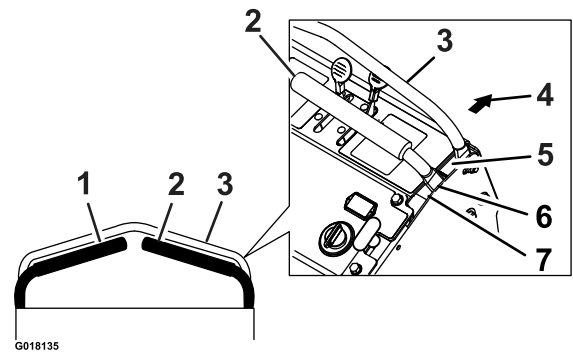

Figure 7

- | | |
|----------------------------|------------|
| 1. LH Motion control lever | 5. Forward |
| 2. RH Motion control lever | 6. Neutral |
| 3. Front reference bar | 7. Reverse |
| 4. Front of unit | |

Choke Control

Located on the control console (black lever) (see [Figure 8](#)).

The choke is used to aid in starting a cold engine. Moving the choke lever forward will put the choke in the “ON” position and moving the choke lever to the rear, to the detent, will put the choke in the “OFF” position. Do Not run a warm engine with choke in the “ON” position.

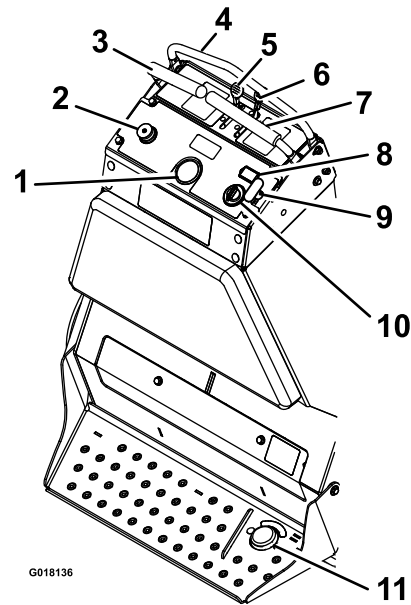

Figure 8

- | | |
|-------------------------------|--|
| 1. Tine down pressure gauge | 7. RH Motion control lever |
| 2. Tine down pressure control | 8. Hour meter |
| 3. LH Motion control lever | 9. Parking brake |
| 4. Front reference bar | 10. Ignition switch |
| 5. Throttle | 11. Tine ground engagement foot switch |
| 6. Choke | |

Throttle Control

Located on the control console (red lever) (see [Figure 8](#)).

The throttle is used to control engine speed. Moving the throttle lever forward will increase engine speed and moving the throttle lever to the rear will decrease engine speed. Moving the throttle forward into the detent is full throttle.

Parking Brake Handle

Located on the right side of the ignition switch on the control console (see [Figure 8](#)).

The brake handle engages a parking brake in the transmissions.

To engage the brake, pull handle out and slide rearward.

To release, push the handle forward into the detent.

When parking on a steep slope, the wheels must be chocked or blocked in addition to the brake being engaged. The unit must be tied down and brake engaged when transporting.

Ignition Switch

Located on the right side of the control console (see [Figure 8](#)).

The ignition switch is used to start and stop the engine. The switch has three positions “OFF”, “ON” and “START”. Insert key into switch and rotate clockwise to the “ON” position. Rotate clockwise to the next position to engage the starter (key must be held against spring pressure in this position). Allow the key to return to the “ON” position immediately after the engine starts.

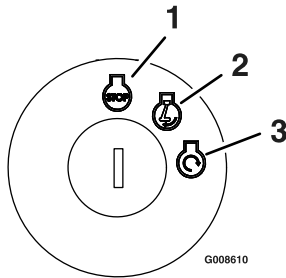

Figure 9

1. Off
2. On
3. Start

Note: To start the engine, the parking brake must be engaged. (It is not necessary for the operator to be on the platform.)

Hour Meter

Located above the ignition switch (see [Figure 8](#)).

The hour meter displays the number of hours of operation that have been logged on the machine.

Fuel Shut-Off Valve

Located under the fuel tank.

The fuel shut-off valve is used to shut off the fuel when the machine will not be used for a few days, during transport to and from the jobsite, and when parked inside a building.

Align valve handle with the fuel line to open. Rotate 90° to close.

Tines Ground Engagement Foot Switch

Keep hands and feet away from the tines. Make sure the tines area is clear of any obstructions before lowering it.

Located on the operator platform (see [Figure 8](#)).

To lower the tines into the ground, stand on the tine ground engagement switch. To raise the tines, remove your foot from the switch.

Tine Down Pressure Control

Located on the left side of the control console (see [Figure 8](#)).

Rotate the control counterclockwise to decrease the pressure and the length of the aeration plug; rotate clockwise to increase pressure and increase the length of the aeration plug.

Tine Down Pressure Gauge

Located in the middle of the control console (see [Figure 8](#)).

The gauge displays the tine down pressure when aerating.

Specifications

Height	52 inches (132.1 cm)
Length	64 inches (162.6 cm)
Width	47.75 inches (121.3 cm)
Aeration Width	30 inches (76.2 cm)
Coring range	2–5 inches (5.1–12.7 cm)
Weight	1015 lb (460 kg)

Operation

Note: Determine the left and right sides of the machine from the normal operating position.

Checking the Engine Oil Level

Service Interval: Before each use or daily

Use only high-quality SAE 10W-30 weight detergent oil that has the American Petroleum Institute (API) service classification SH, SJ, SL or higher.

1. Stop engine and wait for all moving parts to stop. Make sure unit is on a level surface.
2. Check with engine cold.
3. Clean area around dipstick. Remove dipstick and wipe oil off. Reinsert the dipstick according to the engine manufacturer's recommendations. Remove the dipstick and read the oil level.
4. If the oil level is low, wipe off the area around the oil fill cap, remove cap and fill to the "FULL" mark on the dipstick. **Do Not** overfill.

Important: Do Not operate the engine with the oil level below the "LOW" (or "ADD") mark on the dipstick, or over the "FULL" mark.

Filling the Fuel Tank with Gasoline

Fuel tank capacity: 5 US Gallons (18.9 l)

▲ DANGER

In certain conditions, gasoline is extremely flammable and highly explosive. A fire or explosion from gasoline can burn you and others and can damage property.

- Fill the fuel tank outdoors, in an open area, and when the engine is cold. Wipe up any gasoline that spills.
- Do not fill the fuel tank completely full. Add gasoline to the fuel tank until the level is 1/4 to 1/2 in. (6 to 13 mm) below the bottom of the filler neck. This empty space in the tank allows the gasoline to expand.
- Never smoke when handling gasoline, and stay away from an open flame or where a spark may ignite the gasoline fumes.
- Store gasoline in an approved fuel container and keep it out of the reach of children.
- Never buy more than a 30-day supply of gasoline.

▲ DANGER

When fueling, under certain circumstances, a static charge can develop, igniting the gasoline. A fire or explosion from gasoline can burn you and others and damage property.

- Always place gasoline containers on the ground and away from your vehicle before filling.
- Do not fill gasoline containers inside a vehicle or on a truck or trailer bed because interior carpets or plastic truck bed liners may insulate the container and slow the loss of any static charge.
- When practical, remove gasoline-powered equipment from the truck or trailer and refuel the equipment with its wheels on the ground.
- If this is not possible, then refuel such equipment on a truck or trailer from a portable container, not from a gasoline dispenser nozzle.
- If you must use a gasoline dispenser nozzle, keep the nozzle in contact with the rim of the fuel tank or container opening at all times until fueling is complete.
- For best results, use only clean, fresh, unleaded gasoline with an octane rating of 87 or higher ((R+M)/2 rating method).
- Oxygenated fuel with up to 10% ethanol or 15% MTBE by volume is acceptable.
- Do Not use ethanol blends of gasoline (such as E15 or E85) with more than 10% ethanol by volume. Performance problems and/or engine damage may result which may not be covered under warranty.
- Do Not use gasoline containing methanol.
- Do Not store fuel either in the fuel tank or fuel containers over the winter unless a fuel stabilizer is used.
- Do Not add oil to gasoline.

Important: Do not use fuel additives other than a fuel stabilizer/conditioner. Do not use fuel stabilizers with an alcohol base such as ethanol, methanol, or isopropanol.

1. Clean around the fuel tank cap.
2. Remove the cap from the tank.
3. Fill the fuel tank with unleaded gasoline to within 1/4 to 1/2 inch (6 to 13 mm) from the top of the tank. **Do not fill into the filler neck.**

Important: Do not fill the tank more than 1/4 inch (6 mm) from the top of the tank because the gasoline must have room to expand.

4. Install the fuel tank cap and wipe up any spilled gasoline.

Check Safety Interlock System

Service Interval: Before each use or daily

⚠ CAUTION

If safety interlock switches are disconnected or damaged the machine could operate unexpectedly causing personal injury.

- Do not tamper with the interlock switches.
- Check the operation of the interlock switches daily and replace any damaged switches before operating the machine.

Understanding the Safety Interlock System

The safety interlock system is designed to prevent the engine from starting unless the motion control levers are in the neutral position.

Checking the Safety Interlock System

1. Disconnect the spark plug wires.
2. While on level ground, block the wheels of the machine to prevent unintended movement.
3. Disengage the parking brake.
4. With the motion control levers in the neutral position turn the key to the start position — the starter must not crank.

Note: If the machine does not pass this test, do not operate. Contact your authorized **Toro Service Dealer**.

Important: It is essential that the operator safety mechanisms be connected and in proper operating condition prior to use for aerating.

Check for Loose Hardware

Service Interval: Before each use or daily

1. Stop engine, wait for all moving parts to stop, and remove key. Engage parking brake.
2. Visually inspect machine for any loose hardware or any other possible problem. Tighten hardware or correct the problem before operating.

Operating Instructions

Open the Fuel Shut-Off Valve

Rotate the valve and align with the fuel line to open.

Starting the Engine

1. Leave the motion control levers in neutral and engage the parking brake.
2. Place the throttle midway between the “SLOW” and “FAST” positions.

3. On a cold engine, push the choke lever forward into the “ON” position. On a warm engine, leave the choke in the “OFF” position.
4. Turn ignition switch to the “START” position. Release the switch as soon as the engine starts.

Important: Do Not crank the engine continuously for more than ten seconds at a time. If the engine does not start, allow a 60 second cool-down period between starting attempts. Failure to follow these guidelines can burn out the starter motor

5. If the choke is in the “ON” position, gradually return choke to the “OFF” position as the engine warms up.

Lowering the Tines

⚠ DANGER

The rotating tines under the engine deck are dangerous. Tine contact can cause serious injury or kill you.

Do Not put hands or feet under the unit when the engine is running.

1. Set throttle to “MIDWAY” position.
2. Step on the tine ground engagement foot switch to lower the tines. Stand on the switch and move the motion control levers forward to aerate.
3. Adjust the throttle for the working conditions.

Adjusting the Tine Down Pressure

Adjust the plug depth by rotating the tine down pressure control. Rotate the control counterclockwise to decrease the hydraulic down pressure to remove a shorter plug. Rotate clockwise to increase pressure and pull a longer plug.

First time use: set the pressure to 350 psi (24 bar).

Ideal plug depth is 3-4 inches (7.6–10 cm). Rotate the plug depth control to adapt to the soil conditions.

Keep the drive tires on the ground at all times.

Raising the Tines

To raise the tines, remove your foot from the tine ground engagement foot switch.

Important: The tines are rotating when the motion control lever is moved out of the neutral position.

Stopping the Engine

1. Move the motion control levers back to the neutral position and bring the unit to a full stop.
2. Lift your foot off of the tine ground engagement foot switch control to raise the tines.

3. Place the throttle in the midway between the “SLOW” and “FAST” positions.
4. Allow the engine to run for a minimum of 15 seconds, then turn the ignition switch to the “OFF” position to stop the engine.
5. Engage the parking brake.
6. Remove the key to prevent children or other unauthorized persons from starting the engine.
7. Close the fuel shut-off valve when the machine will not be in use for a few days, when transporting, or when the unit is parked inside a building.

Driving the Machine

⚠ CAUTION

Machine can spin very rapidly by positioning one lever too much ahead of the other. Operator may lose control of the machine, which may cause damage to the machine or injury.

- Use caution when making turns.
- Slow the machine down before making sharp turns.

Important: To begin movement (forward or backward), the brake lever must be disengaged (pushed forward) before the motion control levers can be moved.

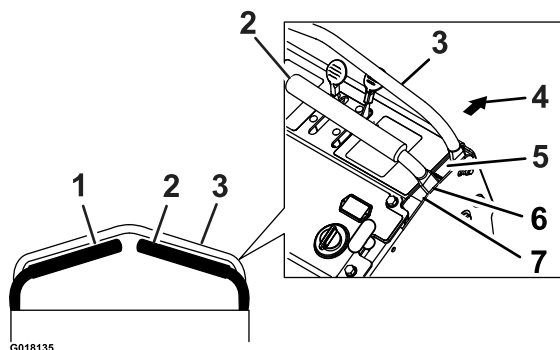

Figure 10

- | | |
|----------------------------|------------|
| 1. LH Motion control lever | 5. Forward |
| 2. RH Motion control lever | 6. Neutral |
| 3. Front reference bar | 7. Reverse |
| 4. Front of unit | |

Driving Forward

1. Make sure the motion control levers are in the neutral position.
2. Release the parking brake.
3. To move forward in a straight line, move both levers forward with equal pressure.

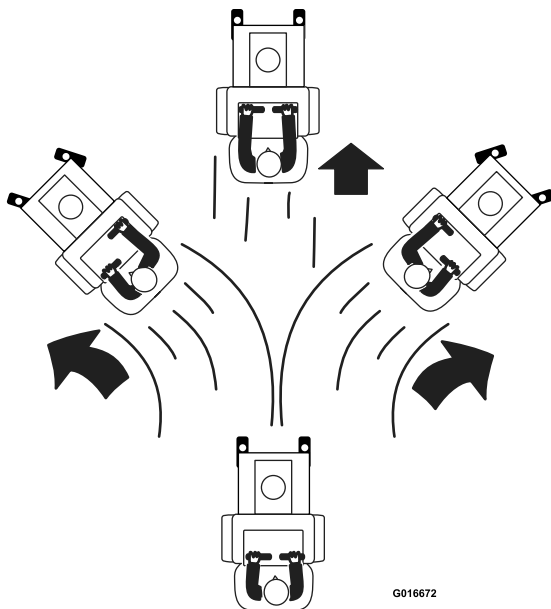

Figure 11

To turn left or right, pull the motion control lever back toward neutral in the desired turn direction. The tines can be in the down position when making gradual turns.

To make zero turns, lift your foot off of the tine engagement foot switch control to raise the tines. The head will raise in one second.

Important: Do Not make a zero turn when the tines are down as turf tearing will result.

The machine will move faster the farther the motion control levers are moved from the neutral position.

4. To stop, position both motion control levers in the neutral operate position.

Driving in Reverse

1. Move the motion control levers to the neutral operate position.
2. To move rearward in a straight line, slowly move both levers rearward with equal pressure.

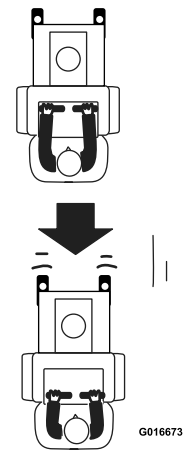

Figure 12

To turn left or right, release pressure on the motion control lever toward the desired turn direction.

To make zero turns, lift your foot off of the tine engagement foot switch to raise the tines. The head will raise in half second.

Important: Do Not make a zero turn when the tines are in the down position.

3. To stop, position both motion control levers in the neutral operate position.

Transporting

Transporting a Unit

Use a heavy-duty trailer or truck to transport the machine. Lock brake and block wheels. Securely fasten the machine to the trailer or truck with straps, chains, cable, or ropes. Be sure that the trailer or truck has all necessary lighting and marking as required by law. Secure a trailer with a safety chain. Refer to your local ordinances for specific trailer and tie-down regulations.

⚠ CAUTION

This unit does not have proper turn signals, lights, reflective markings, or a slow moving vehicle emblem. Driving on a street or roadway without such equipment is dangerous and can lead to accidents causing personal injury. Driving on a street or roadway without such equipment may also be a violation of State laws and the operator may be subject to traffic tickets and/or fines.

Do Not drive a unit on a public street or roadway.

▲ WARNING

Loading a unit on a trailer or truck increases the possibility of backward tip-over. Backward tip-over could cause serious injury or death.

- Use extreme caution when operating a unit on a ramp.
- Use only a single, full width ramp; Do Not use individual ramps for each side of the unit.
- If individual ramps must be used, use enough ramps to create an unbroken ramp surface wider than the unit.
- Do Not exceed a 15° angle between ramp and ground or between ramp and trailer or truck.
- Avoid sudden acceleration while driving unit up a ramp to avoid tipping backward.
- Avoid sudden deceleration while backing unit down a ramp to avoid tipping backward.

Loading a Unit

Use extreme caution when loading units on trailers or trucks. One full width ramp that is wide enough to extend beyond the rear tires is recommended instead of individual ramps for each side of the unit. If it is not possible to use one full width ramp, use enough individual ramps to simulate a full width continuous ramp.

Ramp should be long enough so that the angles between the ramp and the ground and the ramp and the trailer or truck do not exceed 15 degrees. Steeper angles may also cause the unit to tip backward. If loading on or near a slope, position the trailer or truck so it is on the down side of the slope and the ramp extends up the slope. This will minimize the ramp angle. The trailer or truck should be as level as possible.

Important: Do Not attempt to turn the unit while on the ramp, you may lose control and drive off the side.

Avoid sudden acceleration when driving up a ramp and sudden deceleration when backing down a ramp. Both maneuvers can cause the unit to tip backward.

Maintenance

⚠ WARNING

While maintenance or adjustments are being made, someone could start the engine. Accidental starting of the engine could seriously injure you or other bystanders.

Remove the key from the ignition switch, engage parking brake, and pull the wire(s) off the spark plug(s) before you do any maintenance. Also push the wire(s) aside so it does not accidentally contact the spark plug(s).

⚠ WARNING

The engine can become very hot. Touching a hot engine can cause severe burns.

Allow the engine to cool completely before service or making repairs around the engine area.

Note: Thread locking adhesives such as “Loctite 242” or “Fel-Pro, Pro-Lock Nut Type” are used on the following fasteners: sheave retaining bolt in end of engine crankshaft, all set screws, and caster wheel spacer nuts.

Recommended Maintenance Schedule(s)

Maintenance Service Interval	Maintenance Procedure
After the first 5 hours	<ul style="list-style-type: none"> • Change the engine oil.
After the first 100 hours	<ul style="list-style-type: none"> • Check the wheel hub and transmission output shaft nut torque specification. • Check the wheel lug nuts. • Change the auxiliary hydraulic reservoir filter and fluid. • Change the hydraulic transmission filter and fluid.
Before each use or daily	<ul style="list-style-type: none"> • Check the engine oil level. • Check the safety interlock system. • Check for loose hardware. • Check the tines. • Clean the engine and exhaust system area. • Clean the grass and debris build-up from the machine.
Every 50 hours	<ul style="list-style-type: none"> • Lubricate the chains. • Check spark arrester (if equipped). • Check the tire pressures. • Check the condition of the chains. • Check the condition of the sprockets. • Check the condition and tension of the belts. • Check the auxiliary hydraulic oil level. • Check the hydraulic transmission oil level.
Every 80 hours	<ul style="list-style-type: none"> • Remove engine shrouds and clean cooling fins.
Every 100 hours	<ul style="list-style-type: none"> • Grease the jackshaft bearings. • Grease the wheel bearings. • Grease tine shaft bearings. • Grease tine assembly idlers. • Grease control pivots. • Change the engine oil. (May need more often under severe conditions.) • Grease the belt idler pivot.
Every 160 hours	<ul style="list-style-type: none"> • Check the spark plugs.
Every 250 hours	<ul style="list-style-type: none"> • Replace the primary air cleaner element — check secondary air cleaner element; replace if dirty. (May need more often under severe conditions. See the Engine manual for additional information.)

Maintenance Service Interval	Maintenance Procedure
Every 500 hours	<ul style="list-style-type: none"> • Replace the secondary air cleaner element. (May need more often under severe conditions. See the Engine manual for additional information.) • Check the wheel hub and transmission output shaft nut torque specification. • Check the wheel lug nuts. • Change the auxiliary hydraulic reservoir filter and fluid. • Change the hydraulic transmission filter and fluid.
Monthly	<ul style="list-style-type: none"> • Check the battery charge.
Yearly	<ul style="list-style-type: none"> • Grease the front caster pivots. • Grease front caster hubs. • Lubricate the caster wheel hubs.
Yearly or before storage	<ul style="list-style-type: none"> • Touch up chipped paint

Premaintenance Procedures

Note: Shut off engine, wait for all moving parts to stop, engage parking brake, and remove key before servicing, cleaning, or making any adjustments to the unit.

⚠ CAUTION

Raising the unit for service or maintenance relying solely on mechanical or hydraulic jacks could be dangerous. The mechanical or hydraulic jacks may not be enough support or may malfunction allowing the unit to fall, which could cause injury.

Do Not rely solely on mechanical or hydraulic jacks for support. Use adequate jack stands or equivalent support.

Lubrication

Lubricate Chains

Service Interval: Every 50 hours

Important: Do Not lubricate chains with penetrating oil or solvents. Use oil or chain lubricant.

1. Stop engine, wait for all moving parts to stop, and remove key. Engage parking brake.
2. Lift the rear of the unit and support using jack stands or equivalent support.

⚠ CAUTION

Raising the unit for service or maintenance relying solely on mechanical or hydraulic jacks could be dangerous. The mechanical or hydraulic jacks may not be enough support or may malfunction allowing the unit to fall, which could cause injury.

Do Not rely solely on mechanical or hydraulic jacks for support. Use adequate jack stands or equivalent support.

3. Start engine and move throttle control ahead to 1/2 throttle position. Disengage parking brake.

⚠ WARNING

Engine must be running and drive wheels must be turning so adjustments can be performed. Contact with moving parts or hot surfaces may cause personal injury.

Keep fingers, hands, and clothing clear of rotating components and hot surfaces.

4. With the engine running, slowly move the motion control levers forward and lubricate all six chains.

Lubricate Grease Fittings

Note: See chart for service intervals.

1. Stop engine, wait for all moving parts to stop, and remove key. Engage parking brake.
2. Lubricate fittings with NGLI grade #2 multi-purpose gun grease.

Refer to the following chart for fitting locations and lubrication schedule.

Lubrication Chart			
Fitting Locations	Initial Pumps	Number of Places	Service Interval
1. Front Caster Pivots	*0	2	Yearly
2. Jackshaft Bearings	1	6	100 hours
3. Wheel Bearings	1	2	100 hours
4. Tine Shaft Bearings	1	4	100 hours
5. Tine Assembly Idlers	1	2	100 hours
6. Control Pivots	1	4	100 hours
7. Belt Idler Pivot	1	1	100 hours
8. Front Caster Hubs	*0	2	Yearly

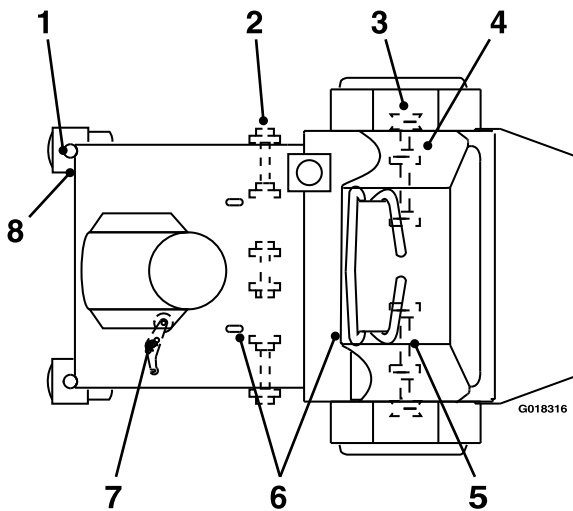

*See step 3 for special lubrication instructions on the front caster pivots.

3. Lubricate front caster pivots once a year. Remove hex plug and cap. Thread grease zerk in hole and pump with grease until it oozes out around top bearing. Remove grease zerk and thread plug back in. Place cap back on.

Lubricate Caster Wheel Hubs

Service Interval: Yearly

1. Stop engine, wait for all moving parts to stop, and remove key. Engage parking brake.

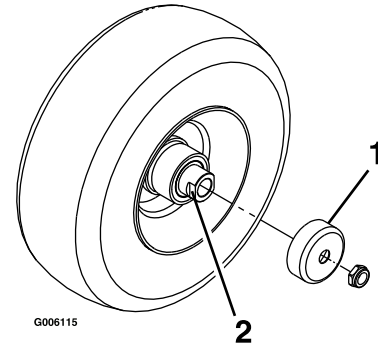

Figure 13

1. Seal guard
 2. Spacer nut with wrench flats
-
2. Remove caster wheel from caster forks.
 3. Remove seal guards from the wheel hub.
 4. Remove one of the spacer nuts from the axle assembly in the caster wheel. Note that thread locking adhesive has been applied to lock the spacer nuts to the axle. Remove the axle (with the other spacer nut still assembled to it) from the wheel assembly.
 5. Pry out seals, and inspect bearings for wear or damage and replace if necessary.
 6. Pack the bearings with a NGLI grade #1 multi-purpose grease.
 7. Insert one bearing, one new seal into the wheel.
- Note:** Replace the seals, part number 103-0063.
8. If the axle assembly has had both spacer nuts removed (or broken loose), apply a thread locking adhesive to one spacer nut and thread onto the axle with the wrench flats facing outward. Do Not thread spacer nut all of the way onto the end of the axle. Leave approximately 1/8 inch (3 mm) from the outer surface of the spacer nut to the end of the axle inside the nut.
 9. Insert the assembled nut and axle into the wheel on the side of the wheel with the new seal and bearing.
 10. With the open end of the wheel facing up, fill the area inside the wheel around the axle full of NGLI grade #1 multi-purpose grease.
 11. Insert the second bearing and new seal into the wheel.
 12. Apply a thread locking adhesive to the 2nd spacer nut and thread onto the axle with the wrench flats facing outward.
 13. Torque the nut to 75-80 in-lb (8-9 N-m), loosen, then re-torque to 20-25 in-lb (2-3 N-m). Make sure axle does not extend beyond either nut.

14. Reinstall the seal guards over the wheel hub and insert wheel into caster fork. Reinstall caster bolt and tighten nut fully.

Important: To prevent seal and bearing damage, check the bearing adjustment often. Spin the caster tire. The tire should not spin freely (more than 1 or 2 revolutions) or have any side play. If the wheel spins freely, adjust torque on spacer nut until there is a slight amount of drag. Reapply thread locking adhesive.

Engine Maintenance

Service Air Cleaner

Service Interval: Every 250 hours—Replace the primary air cleaner element — check secondary air cleaner element; replace if dirty. (May need more often under severe conditions. See the Engine manual for additional information.)

Every 500 hours— Replace the secondary air cleaner element. (May need more often under severe conditions. See the Engine manual for additional information.)

1. Stop engine, wait for all moving parts to stop, and remove key. Engage parking brake.
2. See the Engine Owner's Manual for maintenance instructions.

Change Engine Oil

Service Interval: After the first 5 hours

Every 100 hours (May need more often under severe conditions.)

1. Stop engine, wait for all moving parts to stop, and remove key. Engage parking brake.
2. Drain oil while engine is warm from operation.
3. The oil drain hose assembly is located on the left side of the engine.

Place pan under machine to catch oil. Remove oil drain plug. Allow oil to drain and replace oil drain plug. Torque plug to 20-24 ft-lb (27-33 N-m).

4. Replace the oil filter per the Engine Owner's Manual. Clean around the oil filter and carefully remove the filter by unscrewing it. Make sure no oil drains onto the belt drives through the holes in the engine deck. Before the new filter is installed, apply a thin coating of Toro 4-Cycle Premium Engine Oil on the surface of the rubber seal. Turn filter clockwise until rubber seal contacts the filter adapter, then tighten filter an additional 2/3 to 3/4 turn.
5. Clean around oil fill cap and remove cap. Fill to specified capacity and replace cap.
6. Use oil recommended in the **Check Engine Oil Level** section. **Do Not** overfill. Start the engine and check for leaks. Stop engine and recheck oil level.
7. Wipe up any spilled oil from engine deck mounting surfaces.

Check Spark Plugs

Service Interval: Every 160 hours

Remove spark plugs, check condition and reset gaps, or replace with new plugs. See Engine Owner's Manual.

Check Spark Arrester (if equipped)

Service Interval: Every 50 hours

⚠ WARNING

Hot exhaust system components may ignite gasoline vapors even after the engine is stopped. Hot particles exhausted during engine operation may ignite flammable materials. Fire may result in personal injury or property damage.

Do Not refuel or run engine unless spark arrester is installed.

1. Stop engine, wait for all moving parts to stop, and remove key. Engage parking brake.
2. Wait for muffler to cool.
3. If any breaks in the screen or welds are observed, replace arrester.
4. If plugging of the screen is observed, remove arrester and shake loose particles out of the arrester and clean screen with a wire brush (soak in solvent if necessary). Reinstall arrester on exhaust outlet.

Fuel System Maintenance

Change Fuel Filter

A fuel filter is installed in the fuel line between the fuel tank and the engine. Replace when necessary.

Replacement Filters	
Kawasaki	Kawasaki P/N 49065-7007

Note: It is important to reinstall the fuel line hoses and secure in place, the same way as originally installed at the factory, to keep the fuel line away from components.

Electrical System Maintenance

Check Battery Charge

Service Interval: Monthly

WARNING

CALIFORNIA Proposition 65 Warning

Battery posts, terminals, and related accessories contain lead and lead compounds, chemicals known to the State of California to cause cancer and reproductive harm. Wash hands after handling.

Allowing batteries to stand for an extended period of time without recharging them will result in reduced performance and service life. To preserve optimum battery performance and life, recharge batteries in storage when the open circuit voltage drops to 12.4 volts.

Note: To prevent damage due to freezing, battery should be fully charged before putting away for winter storage.

Check the voltage of the battery with a digital voltmeter. Locate the voltage reading of the battery in the table and charge the battery for the recommended time interval to bring the charge up to a full charge of 12.6 volts or greater.

Important: Make sure the negative battery cable is disconnected and the battery charger used for charging the battery has an output of 16 volts and 7 amps or less to avoid damaging the battery (see chart for recommended charger settings).

Voltage Reading	Percent Charge	Maximum Charger Settings	Charging Interval
12.6 or greater	100%	16 volts/7 amps	No Charging Required
12.4 – 12.6	75–100%	16 volts/7 amps	30 Minutes
12.2 – 12.4	50–75%	16 volts/7 amps	1 Hour
12.0–12.2	25–50%	14.4 volts/4 amps	2 Hours
11.7–12.0	0–25%	14.4 volts/4 amps	3 Hours
11.7 or less	0%	14.4 volts/2 amps	6 Hours or More

Recommended Jump Starting Procedure

1. Check the weak battery for terminal corrosion (white, green, or blue “snow”), it must be cleaned off prior to jump starting. Clean and tighten connections as necessary.

CAUTION

Corrosion or loose connections can cause unwanted electrical voltage spikes at anytime during the jump starting procedure.

Do Not attempt to jump start with loose or corroded battery terminals or damage to the engine may occur.

DANGER

Jump starting a weak battery that is cracked, frozen, has low electrolyte level, or an open/shorted battery cell, can cause an explosion resulting in serious personal injury.

Do Not jump start a weak battery if these conditions exist.

2. Make sure the booster is a good and fully charged lead acid battery at 12.6 volts or greater. Use properly sized jumper cables (4 to 6 AWG) with short lengths to reduce voltage drop between systems. Make sure the cables are color coded or labeled for the correct polarity.

CAUTION

Connecting the jumper cables incorrectly (wrong polarity) can immediately damage the electrical system.

Be certain of battery terminal polarity and jumper cable polarity when hooking up batteries.

Note: The following instructions are adapted from the SAE J1494 Rev. Dec. 2001 – Battery Booster Cables – Surface Vehicle Recommended Practice (SAE – Society of Automotive Engineers).

WARNING

Batteries contain acid and produce explosive gases.

- Shield the eyes and face from the batteries at all times.
- Do Not lean over the batteries.

Note: Be sure the vent caps are tight and level. Place a damp cloth, if available, over any vent caps on both batteries. Be sure the vehicles do not touch and that both electrical systems are off and at the same rated system voltage. These instructions are for negative ground systems only.

3. Connect the positive (+) cable to the positive (+) terminal of the discharged battery that is wired to the starter or solenoid as shown in Figure 14.

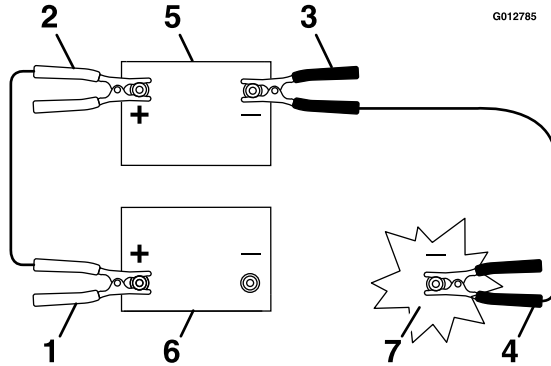

Figure 14

1. Positive (+) cable on discharged battery
2. Positive (+) cable on booster battery
3. Negative (-) cable on the booster battery
4. Negative (-) cable on the engine block
5. Booster battery
6. Discharged battery
7. Engine block

4. Connect the other end of the positive cable to the positive terminal of the booster battery.
5. Connect the black negative (-) cable to the other terminal (negative) of the booster battery.
6. MAKE THE FINAL CONNECTION ON THE ENGINE BLOCK OF THE STALLED VEHICLE (NOT TO THE NEGATIVE POST) AWAY FROM THE BATTERY. STAND BACK.
7. Start the vehicle and remove the cables in the reverse order of connection (the engine block (black) connection is the first to disconnect).

Drive System Maintenance

Check Tire Pressures

Service Interval: Every 50 hours

1. Stop engine, wait for all moving parts to stop, and remove key. Engage parking brake.
2. Check tire pressure in drive tires.
3. Inflate drive tires to 12-14 psi (83-97 kPa).
4. Semi-pneumatic caster tires do not need to be inflated.

Check Condition Of Chains

Service Interval: Every 50 hours

1. Stop engine, wait for all moving parts to stop, and remove key. Engage parking brake.
2. Check the chains on both sides of the unit for proper tension. The chains should be able to move up and down 1/2-3/4 inch (12-19 mm).
3. If chains pop or snap see **Jackshaft Drive Chain Tension Adjustment, Drive Chain Tension Adjustment, or Tine Drive Tension Adjustment.**

Check Condition Of Sprockets

Service Interval: Every 50 hours

1. Stop engine, wait for all moving parts to stop, and remove key. Engage parking brake.
2. Inspect sprockets for wear and replace as required.

Wheel Hub Nut and Transmission Output Shaft Torque Specification

Service Interval: After the first 100 hours

Every 500 hours thereafter

Torque the nut on the wheel motor tapered shaft to 140-155 ft-lb (190-210 N-m).

Note: Do Not use anti-seize compound on the wheel hub.

Jackshaft Drive Chain Tension Adjustment

1. Stop engine, wait for all moving parts to stop, and remove key. Engage parking brake.
2. Lift the rear of the unit and support using jack stands or equivalent support.

3. Check the chains on both sides of the unit for proper tension. The chains should be able to move up and down 1/2-3/4 inch (12-19 mm).
4. Loosen the hydro mounting bolts and slide to adjust the tension.
5. Tighten hydro mounting bolts.
6. Adjust motion controls as stated in the Motion Control Linkage Adjustment section.

Drive Wheel Chain Tension Adjustment

1. Stop engine, wait for all moving parts to stop, and remove key. Engage parking brake.
2. Lift the rear of the unit and support using jack stands or equivalent support.
3. Check the chains on both sides of the unit for proper tension. The chains should be able to move up and down 1/2-3/4 inch (12-19 mm).
4. Adjust the idler sprockets.
5. Recheck the chain tension and tighten the idler bolt.

Caster Pivot Bearings Pre-Load Adjustment

Remove dust cap from caster and tighten nyloc nut until washers are flat and back off 1/4 of a turn to properly set the pre-load on the bearings. If disassembled, make sure the spring disc washers are reinstalled as shown in [Figure 15](#).

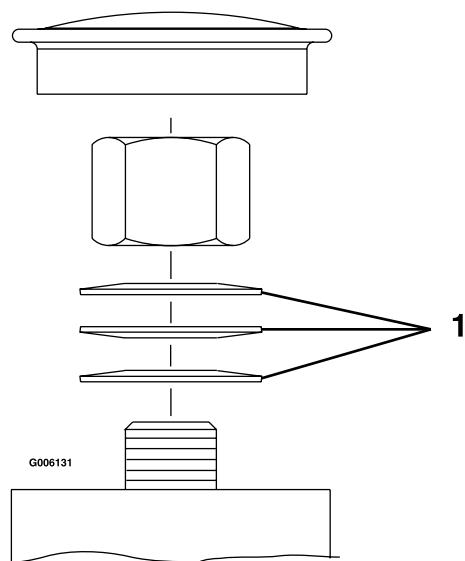

Figure 15

1. Spring disc washers

Brake Maintenance

Adjusting the Parking Brake

If the parking brake does not hold securely, an adjustment is required.

1. Park the machine on a level surface.
2. Shut off engine and wait for all moving parts to stop.
3. Check the air pressure in the drive tires. If needed, adjust to the recommended inflation; refer to **Checking the Tire Pressure** in Drive System Maintenance.
4. Disengage the parking brake.
5. Loosen the adjustment nut on the brake cable under the console.
6. Engage the parking brake.
7. Adjust the nut position until 3 1/8 inch (7.9 cm) from the bottom of the link to the bottom of the spring. See [Figure 16](#).

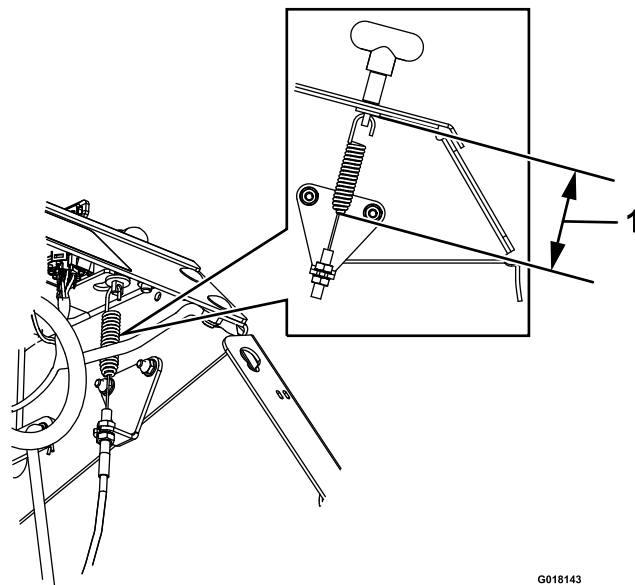

Figure 16

1. 3 1/8 inch (7.9 cm)

8. Tighten the cable adjustment nuts.
9. Check the parking brake; repeat steps 5 through 8 if necessary.

Adjusting the Brake Switch

1. Park the machine on a level surface.
2. Shut off the engine and wait for all moving parts to stop.
3. Prior the adjusting the brake switch ensure the parking brake is properly adjusted. See [Adjusting the Parking Brake](#) (page 29).

4. Engage the parking brake.
5. Check the distance from the parking brake switch bracket to the hydro brake arm. The distance should be 1/8 inch (3.2 mm). See [Figure 17](#).

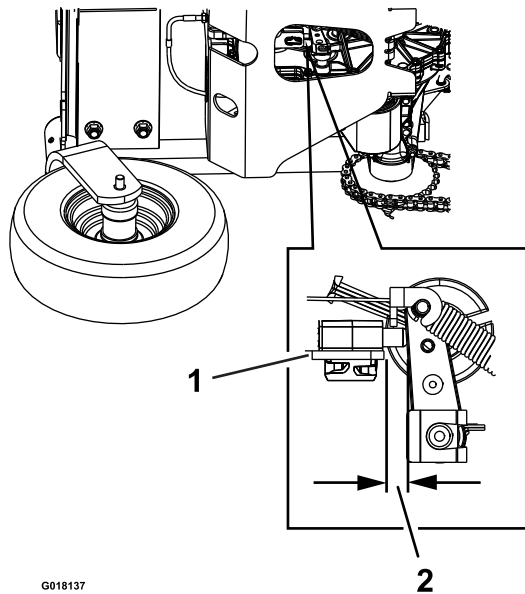

Figure 17

1. Parking brake switch bracket
2. 1/8 inch (3.2 mm) gap

6. If adjustment is required, loosen the bolt holding the parking brake switch bracket and adjust the distance between the parking brake switch bracket and the hydro brake arm to be 1/8 inch.
7. Tighten the bolt holding the parking brake bracket.

Belt Maintenance

Check Condition and Tension of Belts

Service Interval: Every 50 hours

1. Stop engine, wait for all moving parts to stop, and remove key. Engage parking brake.
2. Lift the front of the unit and support using jack stands or equivalent support.
3. Check the auxiliary pump drive belt condition and tension; belt should be snug. See **Auxiliary Pump Drive Belt Adjustment**.
4. Check the condition and tension of the transmission drive belt. See **Transmission Drive Belt Tension Adjustment**.

Auxiliary Pump Drive Belt Adjustment

1. Stop engine, wait for all moving parts to stop, and remove key. Engage parking brake.
2. To tighten belt, loosen the 3/8 inch nyloc nut on auxiliary pump belt idler pulley. Slide bolt inward in slot and retighten nyloc nut.
3. When properly adjusted, the belt should have 1/2 inch (1.3 cm) of deflection with three pounds of pressure on the belt midway between the auxiliary pump and engine pulley.

Transmission Drive Belt Tension Adjustment

- **Checking Existing Belt:**

1. Stop engine, wait for all moving parts to stop, and remove key. Engage parking brake.
2. Measure the spring length from inside the idler bracket to the inside of the flanged nut as shown in [Figure 18](#).

Controls System Maintenance

Motion Control Linkage Adjustment

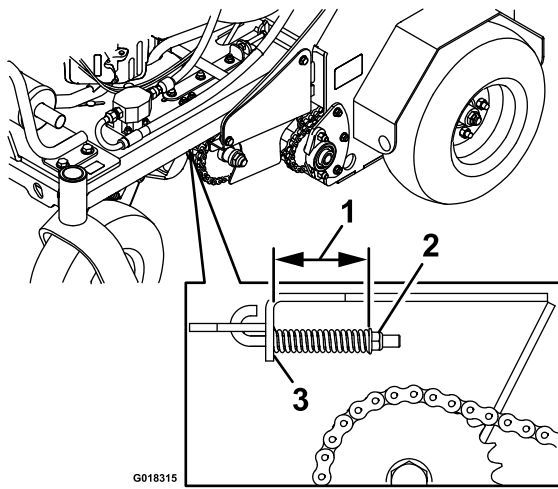

Figure 18

1. Measure spring length
2. Flanged nut
3. Idler bracket

3. Adjust the nut until the spring length measures 2 5/8 to 2 3/4 inches (67–70 mm) maximum.

• Installing a New Belt:

1. Stop engine, wait for all moving parts to stop, and remove key. Engage parking brake.
2. Install the new belt.
3. Measure the spring length from inside the idler bracket to the inside of the flanged nut as shown in [Figure 18](#). Set the spring length to 2 3/8 inches (60 mm).
4. Start the engine and allow the machine to run for 30 seconds.
5. Stop engine, wait for all moving parts to stop, and remove key.
6. Check the spring length and adjust the nut until the spring measures 2 3/8 inches (60 mm).

1. Park the machine on a level surface.
2. Shut off engine and wait for all moving parts to stop.
3. Push the control levers all the way forward to the front reference bar.
4. Remove the clevis pin on the turnbuckle of the motion control linkage. Rotate the turnbuckle counterclockwise (as viewed from the top of the machine) until there is a gap between the control lever and the front reference bar.

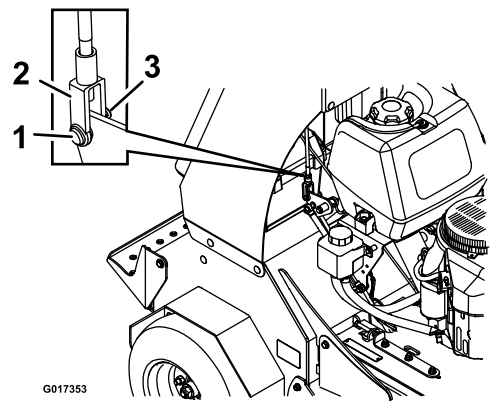

Figure 19

1. Clevis pin
2. Turnbuckle
3. Cotter pin

5. Holding the control levers forward, rotate the turnbuckle clockwise until there is a minimal gap or contact between the control lever and the front reference bar. Rotate the turnbuckle clockwise one more full turn.
6. Reinstall the clevis pin.
7. Repeat steps 3 through 6 for other motion control linkage.

Hydraulic System Maintenance

Check Auxiliary Hydraulic Oil Level

Service Interval: Every 50 hours

1. Lower the tines to the ground.
2. Stop engine and wait for all moving parts to stop, and remove key. Engage parking brake.
3. Clean area around hydraulic reservoir cap and remove cap. Oil level should be to the top of the baffle inside the tank. If not, add oil. Use AW-32 hydraulic oil. Replace hydraulic reservoir cap and tighten until snug. Do Not overtighten.

Note: The baffle is labeled “HOT” and “COLD”. The oil level varies with the temperature of the oil. The “HOT” level shows the level of oil when it is at 225°F (107°C). The “COLD” level shows the level of the oil when it is at 75°F (24°C). Fill to the appropriate level depending upon the temperature of the oil. For example: If the oil is about 150°F (65°C), fill to halfway between the “HOT” and “COLD” levels. If the oil is at room temperature (about 75°F (24°C)), fill only to the “COLD” level.

Check Hydraulic Transmission Oil Level

Service Interval: Every 50 hours

1. Stop engine and wait for all moving parts to stop, and remove key. Engage parking brake.
2. With the unit cold, check the expansion tank and if necessary add Toro Hypr-oil 500 hydraulic oil to the Full Cold line.

Change Auxiliary Hydraulic Reservoir Fluid and Filter

Service Interval: After the first 100 hours

Every 500 hours thereafter

1. Stop engine, wait for all moving parts to stop, and remove key or spark plug wire(s). Engage parking brake.
2. Carefully clean area around the front of the auxiliary pump and fill cap; also clean around the filter. It is important that no dirt or contamination enter hydraulic system.
3. Unscrew the suction hose from the pump fitting and allow oil to drain.
4. Unscrew the filter to remove and allow oil to drain.

Important: Apply a thin coat of oil on the surface of the rubber seal.

Turn filter clockwise until rubber seal contacts the filter adapter, then tighten the filter an additional 2/3 to 3/4 turn.

5. Reinstall the hose and torque to 37 ft-lb (50 N-m).
6. Add AW-32 hydro oil until the level reaches the “cold fill line” located on the reservoir tank. Start engine and raise and lower the tines. Lower the tines to the ground and refill the reservoir to the “cold fill line”.

Note: Do Not change the hydraulic system oil unless it is felt the oil has been contaminated or been extremely hot.

Changing oil unnecessarily could damage hydraulic system by introducing contaminants into the system.

Change Hydraulic Transmission Filters and Fluid

Service Interval: After the first 100 hours

Every 500 hours thereafter

1. Stop engine, wait for all moving parts to stop, and remove key or spark plug wire(s). Engage parking brake.
2. Locate the two filters under the transmissions. Remove filter guards.
3. Carefully clean area around filters. It is important that no dirt or contamination enter hydraulic system.
4. Unscrew filters to remove and allow oil to drain from drive system.

Important: Before reinstalling new filters, apply a thin coat of Toro Hypr-oil 500 hydraulic oil on the surface of the filters rubber seal.

Turn the filters clockwise until rubber seal contacts the filter adapter then tighten the filter an additional 3/4 to 1 full turn.

5. Remove the vent plug on each transmission and fill through expansion reservoir, when oil comes out of vent reinstall plug.

Toro Hypr-oil 500 hydraulic oil is recommended. Refer to the chart for an acceptable alternative:

Hydro Oil	Change Interval
Toro Hypr-oil 500 hydraulic oil (Preferred)	500 Hours
Mobil 1 15W50	250 Hours

Torque plugs to 180 in-lb (244 N-m). Continue to add hydraulic oil until it reaches the Full Cold line on the expansion reservoir.

6. Raise the rear of machine up and support with jack stands (or equivalent support) just high enough to allow drive wheels to turn freely.

⚠ CAUTION

Raising the unit for service or maintenance relying solely on mechanical or hydraulic jacks could be dangerous. The mechanical or hydraulic jacks may not be enough support or may malfunction allowing the unit to fall, which could cause injury.

Do Not rely solely on mechanical or hydraulic jacks for support. Use adequate jack stands or equivalent support.

7. Start engine and move throttle control ahead to 1/2 throttle position. Disengage parking brake.

⚠ WARNING

Engine must be running and drive wheels must be turning so motion control adjustment can be performed. Contact with moving parts or hot surfaces may cause personal injury.

Keep fingers, hands, and clothing clear of rotating components and hot surfaces.

- A. With the engine running, slowly move the directional control in both forward and reverse directions (5 to 6 times). Check the oil level, and add oil as required after stopping the engine.
- B. It may be necessary to repeat step A. until all the air is completely purged from the system. When the transaxle operates at normal noise levels and moves smoothly forward and reverse at normal speeds, then the transaxle is considered purged.

Note: Do Not change the hydraulic system oil (except for what can be drained when changing filter), unless it is felt the oil has been contaminated or been extremely hot.

Changing oil unnecessarily could damage hydraulic system by introducing contaminants into the system.

Tine Maintenance

Check Tines

Service Interval: Before each use or daily

1. Stop engine, wait for all moving parts to stop, and remove key. Engage parking brake.
2. Lift the rear of the unit and support using jack stands or equivalent support.

⚠ CAUTION

Raising the unit for service or maintenance relying solely on mechanical or hydraulic jacks could be dangerous. The mechanical or hydraulic jacks may not be enough support or may malfunction allowing the unit to fall, which could cause injury.

Do Not rely solely on mechanical or hydraulic jacks for support. Use adequate jack stands or equivalent support.

3. Remove and retain the two bolts from the rear cover panel.
4. Remove rocks and other debris from the tines.
5. Inspect the tines and replace as required.

Tine Drive Chain Adjustment

1. Stop engine, wait for all moving parts to stop, and remove key. Engage parking brake.
2. Lift the rear of the unit and support using jack stands or equivalent support.
3. Check the chains on both sides of the unit for proper tension. The chains should be able to move up and down 1/2-3/4 inch (12-19 mm).
4. Adjust the idler sprocket.
5. Recheck the chain tension and tighten the idler bolt.

Cleaning

Clean Engine and Exhaust System Area

Service Interval: Before each use or daily (May be required more often in dry or dirty conditions.)

⚠ CAUTION

Excessive debris around engine cooling air intake and exhaust system area can cause engine, exhaust area, and hydraulic system to overheat which can create a fire hazard.

Clean all debris from engine and exhaust system area.

1. Stop engine, wait for all moving parts to stop, and remove key. Engage parking brake.
2. Clean all debris from rotating engine air intake screen, around engine shrouding, and exhaust system area.
3. Wipe up any excessive grease or oil around the engine and exhaust system area.

Remove Engine Shrouds and Clean Cooling Fins

Service Interval: Every 80 hours

1. Stop engine, wait for all moving parts to stop, and remove key. Engage parking brake.
2. Remove cooling shrouds from engine and clean cooling fins. Also clean dust, dirt, and oil from external surfaces of engine which can cause improper cooling.
3. Make sure cooling shrouds are properly reinstalled. Operating the engine without cooling shrouds will cause engine damage due to overheating.

Clean Debris From Machine

Service Interval: Before each use or daily

1. Stop engine, wait for all moving parts to stop, and remove key. Engage parking brake.
2. Clean off any oil, debris, or grass build-up on the machine and aerator deck, especially under chain guards, around the fuel tank, around engine and exhaust area.

Waste Disposal

Motor Oil Disposal

Engine oil and hydraulic oil are both pollutants to the environment. Dispose of used oil at a certified recycling center or according to your state and local regulations.

Battery Disposal

⚠ DANGER

Battery electrolyte contains sulfuric acid, which is poisonous and can cause severe burns. Swallowing electrolyte can be fatal or if it touches skin can cause severe burns.

- **Wear safety glasses to shield eyes, and rubber gloves to protect skin and clothing when handling electrolyte.**
- **Do Not swallow electrolyte.**
- **In the event of an accident, flush with water and call a doctor immediately.**

Federal law states that batteries should not be placed in the garbage. Management and disposal practices must be within relevant federal, state, or local laws.

If a battery is being replaced or if the unit containing the battery is no longer operating and is being scrapped, take the battery to a local certified recycling center. If no local recycling is available return the battery to any certified battery reseller.

Storage

1. Raise the tines, stop the machine, stop the engine, set the parking brake, and remove the key.
2. Remove dirt and grime from the entire machine.

Important: You can wash the machine with mild detergent and water. Do not pressure wash the machine. Avoid excessive use of water, especially near the engine and hydrostatic drive.

3. Service the air cleaner.
4. Lubricate the machine.
5. Change the engine oil.
6. Check and tighten all bolts, nuts, and screws. Repair or replace any part that is damaged.
7. Paint all scratched or bare metal surfaces. Paint is available from your Authorized Service Dealer.
8. Store the machine in a clean, dry garage or storage area.
9. Cover the machine to protect it and keep it clean.

Troubleshooting

Important: It is essential that all operator safety mechanisms be connected and in proper operating condition prior to use.

When a problem occurs, do not overlook the simple causes. For example: starting problems could be caused by an empty fuel tank.

The following table lists some of the common causes of trouble. Do Not attempt to service or replace major items or any items that call for special timing of adjustments procedures (such as valves, governor, etc.). Have this work done by your **Engine Service Dealer**.

Note: When disconnecting electrical connectors Do Not pull on the wires to separate the connectors.

Problem	Possible Cause	Corrective Action
Starter does not crank.	<ol style="list-style-type: none"> 1. Parking brake is not engaged. 2. Brake switch not adjusted properly. 3. Battery does not have a full charge. 4. Electrical connections are corroded, loose or faulty. 5. Fuse is blown. 6. Relay or switch is defective. 	<ol style="list-style-type: none"> 1. Engage the parking brake. 2. Adjust the brake switch. 3. Charge the battery. See Check Battery Charge and Recommended Jump Starting Procedure sections in Maintenance. 4. Check the electrical connections for good contact. Clean connector terminals thoroughly with electrical contact cleaner, apply dielectric grease and reconnect. 5. Replace the blown fuse. 6. Contact an Authorized Service Dealer.
Engine will not start, starts hard, or fails to keep running	<ol style="list-style-type: none"> 1. Fuel tank is empty. 2. Fuel shutoff valve is closed. 3. The throttle and choke are not in the correct position. 4. Dirt in fuel filter. 5. Dirt, water, or stale fuel is in the fuel system. 6. Air cleaner is dirty. 7. Electrical connections are corroded, loose or faulty. 8. Relay or switch is defective. 9. Faulty spark plug. 10. Spark plug wire is not connected. 	<ol style="list-style-type: none"> 1. Fill the fuel tank. 2. Open the fuel shutoff valve. 3. Be sure the throttle control is midway between the "SLOW" and "FAST" positions, and the choke is in the "ON" position for a cold engine or the "OFF" position for a warm engine. 4. Replace the fuel filter. 5. Contact an Authorized Service Dealer. 6. Clean or replace the air cleaner element. 7. Check the electrical connections for good contact. Clean connector terminals thoroughly with electrical contact cleaner, apply dielectric grease and reconnect. 8. Contact an Authorized Service Dealer. 9. Clean, adjust or replace spark plug. 10. Check the spark plug wire connection.
Engine loses power.	<ol style="list-style-type: none"> 1. Engine load is excessive. 2. Air cleaner is dirty. 3. Oil level in the crankcase is low. 4. Cooling fins and air passages for the engine are plugged. 5. Dirt in fuel filter. 6. Dirt, water, or stale fuel is in the fuel system. 	<ol style="list-style-type: none"> 1. Reduce the ground speed or aeration depth. 2. Clean or replace the air cleaner element. 3. Add oil to the crankcase. 4. Remove the obstructions from the cooling fins and air passages. 5. Replace the fuel filter. 6. Contact an Authorized Service Dealer.

Problem	Possible Cause	Corrective Action
Engine overheats.	<ol style="list-style-type: none"> 1. Engine load is excessive. 2. Oil level in the crankcase is low. 3. Cooling fins and air passages for the engine are plugged. 	<ol style="list-style-type: none"> 1. Reduce the ground speed or aeration depth. 2. Add oil to the crankcase. 3. Remove the obstructions from the cooling fins and air passages.
Machine pulls left or right (with levers fully forward).	<ol style="list-style-type: none"> 1. Tire pressure in drive tires not correct. 2. Tracking needs adjustment. 	<ol style="list-style-type: none"> 1. Adjust tire pressure in the drive tires. 2. See Motion Control Linkage Adjustment.
Machine does not drive.	<ol style="list-style-type: none"> 1. Drive or pump belt is worn, loose or broken. 2. Drive or pump belt is off a pulley. 	<ol style="list-style-type: none"> 1. Change the belt. 2. Change the belt.
Abnormal vibration.	<ol style="list-style-type: none"> 1. Tine(s) is/are bent. 2. Tine mounting bolt is loose. 3. Engine mounting bolts are loose. 4. Loose engine pulley or idler pulley. 5. Engine pulley is damaged. 6. Belt is damaged. 7. Chains are not properly tensioned. 	<ol style="list-style-type: none"> 1. Install new tine(s). 2. Tighten the tine mounting bolt. 3. Tighten the engine mounting bolts. 4. Tighten the appropriate pulley. 5. Contact an Authorized Service Dealer. 6. Install new belt. 7. See Jackshaft Drive Chain Tension Adjustment, Drive Wheel Chain Tension Adjustment, and Tine Drive Chain Adjustment.
Tines do not raise.	<ol style="list-style-type: none"> 1. Auxiliary pump belt problem. 2. Tine down pressure setting is too low. 3. Short in harness. 4. Auxiliary reservoir is low on oil. 	<ol style="list-style-type: none"> 1. Tension or replace belt. 2. Increase down pressure. 3. Contact an Authorized Service Dealer. 4. Add oil to reservoir.
Tines do not engage the ground.	<ol style="list-style-type: none"> 1. Tine down pressure setting is too low. 2. Harness/switch is damaged. 3. Auxiliary reservoir is low on oil. 4. Cylinder stop is in place. 	<ol style="list-style-type: none"> 1. Increase tine down pressure. 2. Contact an Authorized Service Dealer. 3. Add oil to reservoir. 4. Remove cylinder stop, clevis pin and hair pin.

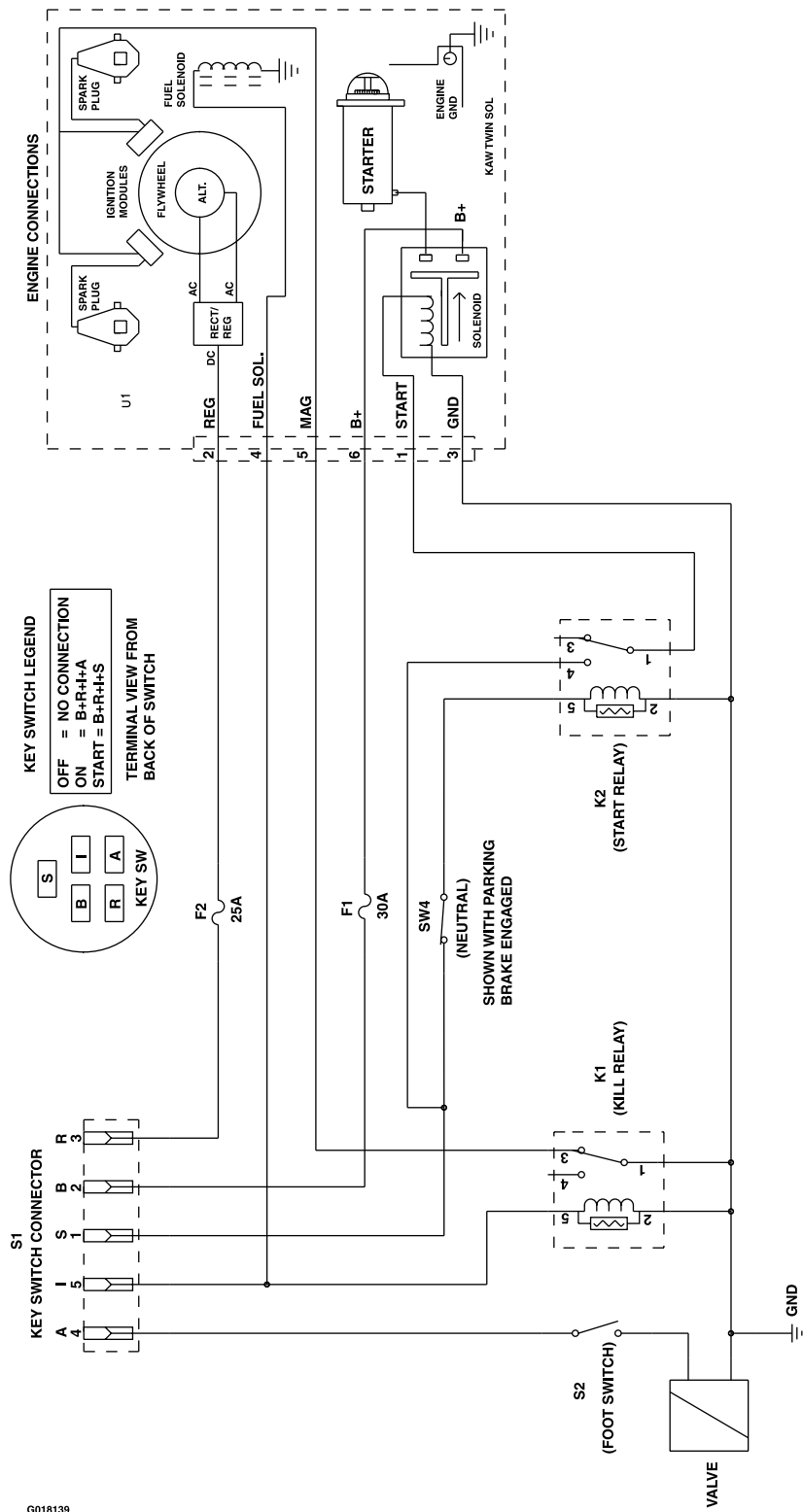

G018139

Electrical Schematic (Rev. A)

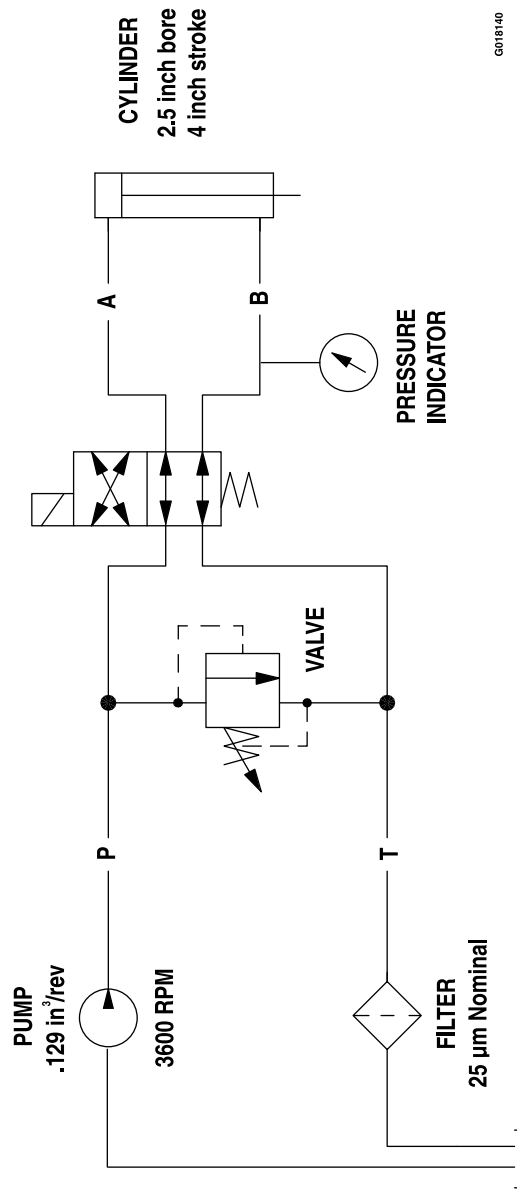

Hydraulic Diagram (Rev. A)

GD18140

Notes:

Notes:

Notes:



Toro Compact Utility Equipment Warranty

A One-Year Limited Warranty

CUE Products

Conditions and Products Covered

The Toro® Company and its affiliate, Toro Warranty Company, pursuant to an agreement between them, jointly warrant your Toro Compact Utility Equipment ("Product") to be free from defects in materials or workmanship. The following time periods apply from the date of purchase:

Products	Warranty Period
Loaders, Trenchers, Stump Grinders, Chippers, Log Splitters and Attachments Kohler Engines	1 year or 1000 operating hours, whichever occurs first
Kohler Engines	3 years
All other Engines	2 years

Where a warrantable condition exists, we will repair the Product at no cost to you including diagnosis, labor, and parts.

Instructions for Obtaining Warranty Service

If you think that your Toro Product contains a defect in materials or workmanship, follow this procedure:

1. Contact any Authorized Toro Compact Utility Equipment (CUE) Service Dealer to arrange service at their dealership. To locate a dealer convenient to you, access our website at www.Toro.com. You may also call our Toro Customer Care Department toll free at 888-865-5676 (U.S. customers) or 888-865-5691 (Canadian customers).
2. Bring the product and your proof of purchase (sales receipt) to the Service Dealer.
3. If for any reason you are dissatisfied with the Service Dealer's analysis or with the assistance provided, contact us at:

LCB Customer Care Department
Toro Warranty Company
8111 Lyndale Avenue South
Bloomington, MN 55420-1196
Toll Free: 888-865-5676 (U.S. customers)
Toll Free: 888-865-5691 (Canada customers)

Owner Responsibilities

You must maintain your Toro Product by following the maintenance procedures described in the *Operator's Manual*. Such routine maintenance, whether performed by a dealer or by you, is at your expense. Parts scheduled for replacement as required maintenance ("Maintenance Parts"), are warranted for the period of time up to the scheduled replacement time for that part. Failure to perform required maintenance and adjustments can be grounds for disallowing a warranty claim.

Items and Conditions Not Covered

Not all product failures or malfunctions that occur during the warranty period are defects in materials or workmanship. This express warranty does not cover the following:

- Product failures which result from the use of non-Toro replacement parts, or from installation and use of add-on, modified, or unapproved accessories
- Product failures which result from failure to perform required maintenance and/or adjustments
- Product failures which result from operating the Product in an abusive, negligent or reckless manner
- Parts subject to consumption through use unless found to be defective. Examples of parts which are consumed, or used up, during normal Product operation include, but are not limited to, teeth, tines, blades, spark plugs, tires, tracks, filters, chains, etc.
- Failures caused by outside influence. Items considered to be outside influence include, but are not limited to, weather, storage practices, contamination, use of unapproved coolants, lubricants, additives, or chemicals, etc.
- Normal "wear and tear" items. Normal "wear and tear" includes, but is not limited to, worn painted surfaces, scratched decals or windows, etc.
- Any component covered by a separate manufacturer's warranty
- Pickup and delivery charges

General Conditions

Repair by an Authorized Toro Compact Utility Equipment (CUE) Service Dealer is your sole remedy under this warranty.

Neither The Toro® Company nor Toro Warranty Company is liable for indirect, incidental or consequential damages in connection with the use of the Toro Products covered by this warranty, including any cost or expense of providing substitute equipment or service during reasonable periods of malfunction or non-use pending completion of repairs under this warranty. All implied warranties of merchantability and fitness for use are limited to the duration of this express warranty. Some states do not allow exclusions of incidental or consequential damages, or limitations on how long an implied warranty lasts, so the above exclusions and limitations may not apply to you.

This warranty gives you specific legal rights, and you may also have other rights which vary from state to state.

Except for the engine warranty coverage and the Emissions warranty referenced below, if applicable, there is no other express warranty. The Emissions Control System on your Product may be covered by a separate warranty meeting requirements established by the U.S. Environmental Protection Agency (EPA) or the California Air Resources Board (CARB). The hour limitations set forth above do not apply to the Emissions Control System Warranty. Refer to the California Emission Control Warranty Statement supplied with your Product or contained in the engine manufacturer's documentation for details.

Countries Other than the United States or Canada

Customers who have purchased Toro products exported from the United States or Canada should contact their Toro Distributor (Dealer) to obtain guarantee policies for your country, province, or state. If for any reason you are dissatisfied with your Distributor's service or have difficulty obtaining guarantee information, contact the Toro importer. If all other remedies fail, you may contact us at Toro Warranty Company.