

13/30

HERITAGE TRACTOR
CODE131B

INSTRUCTION BOOK

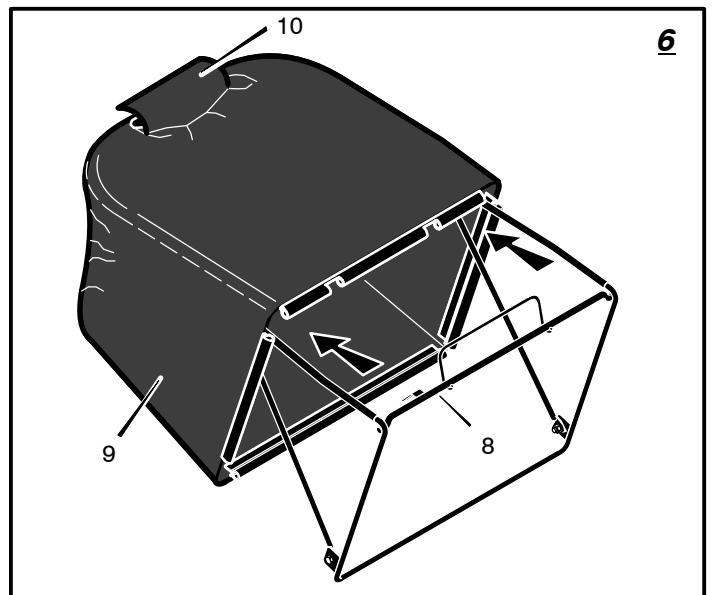

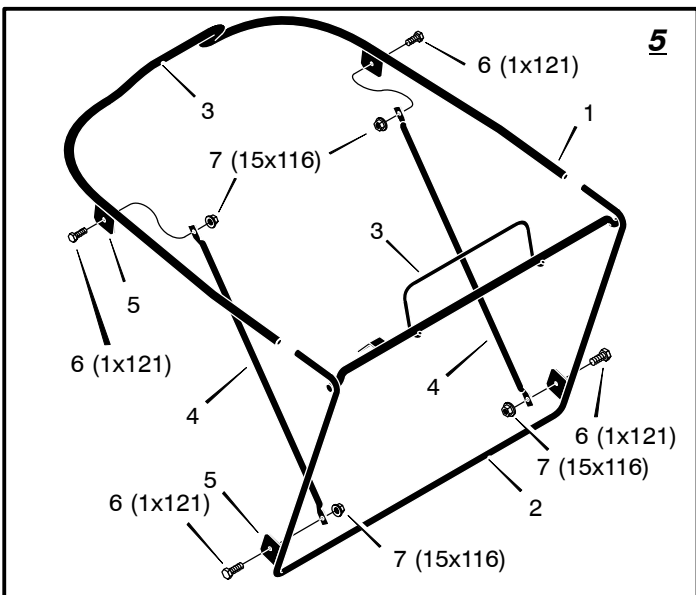
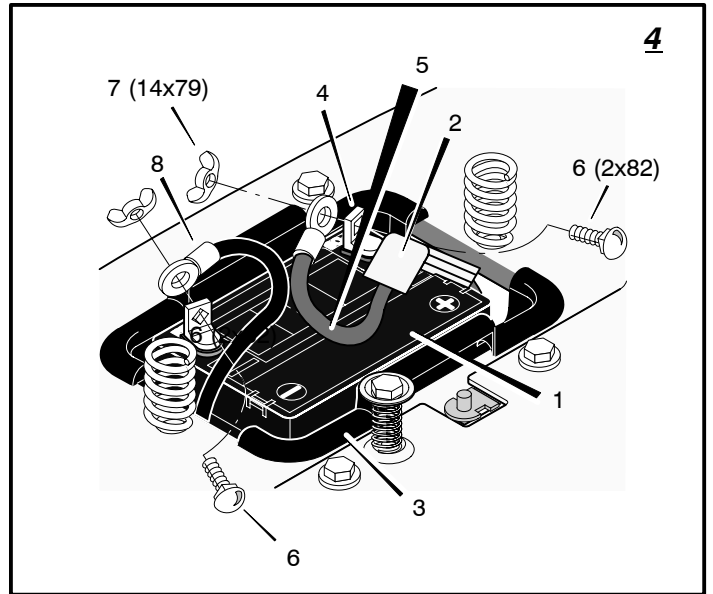
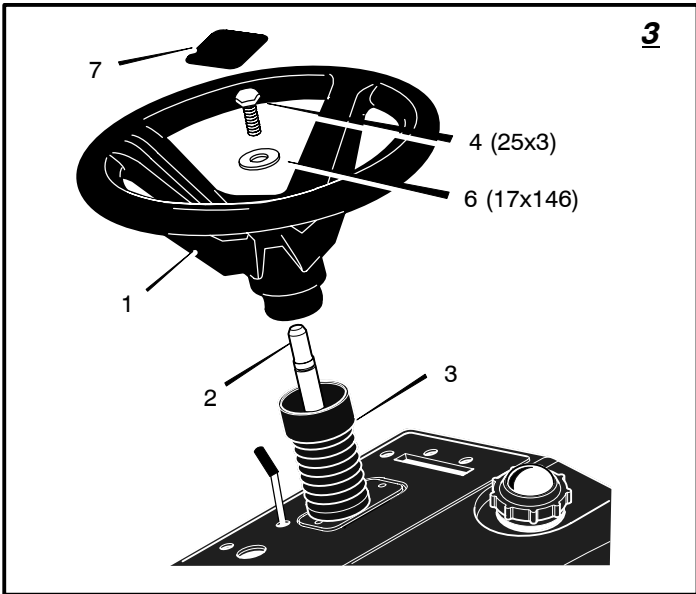
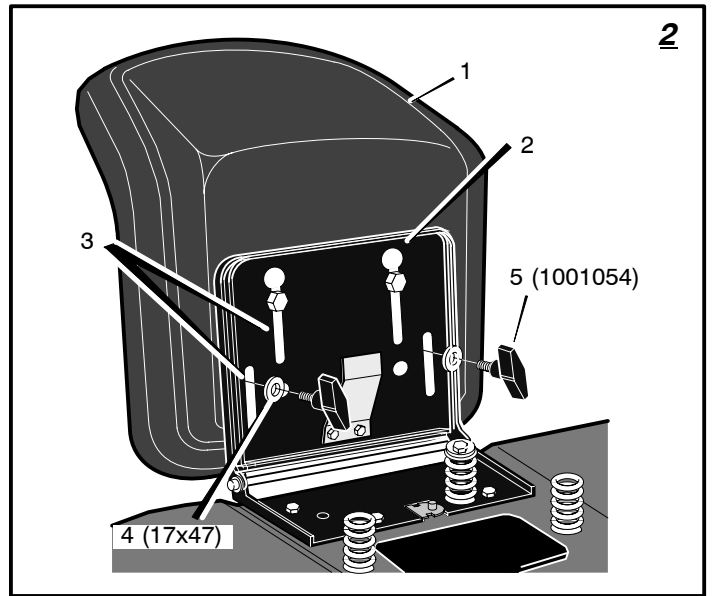
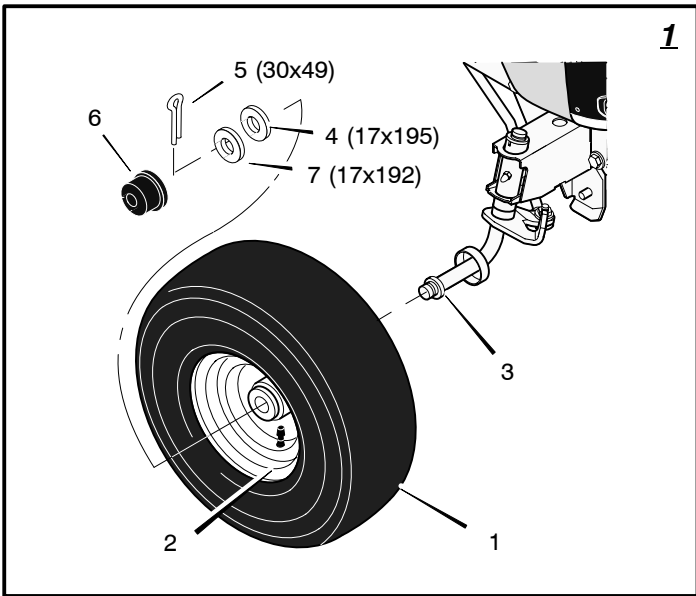
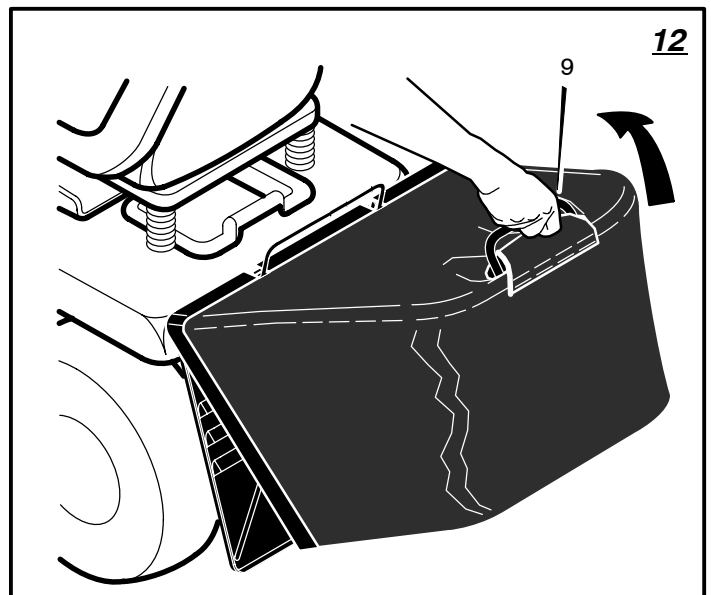
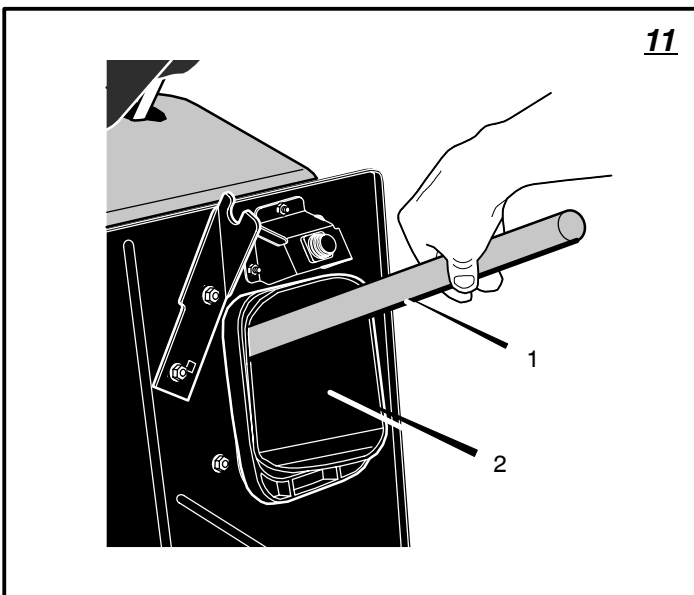
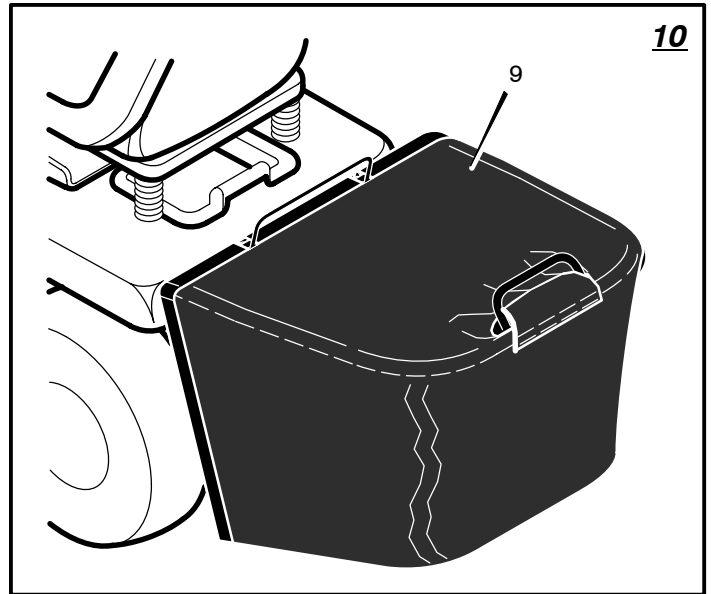
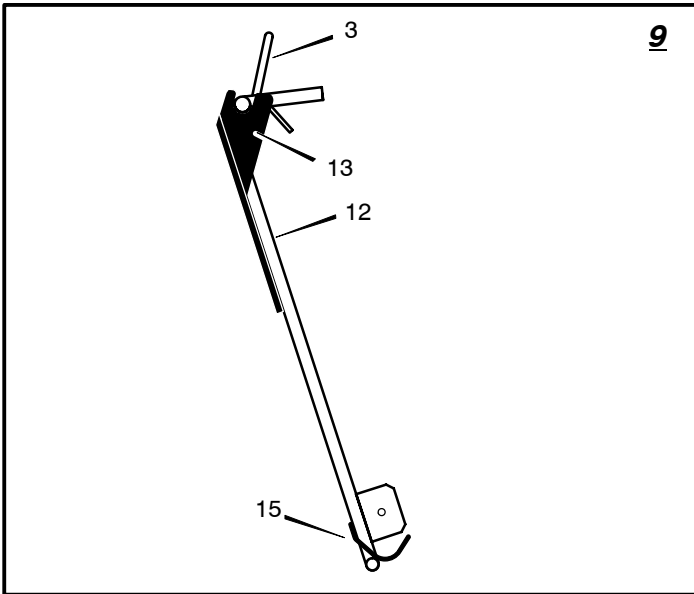
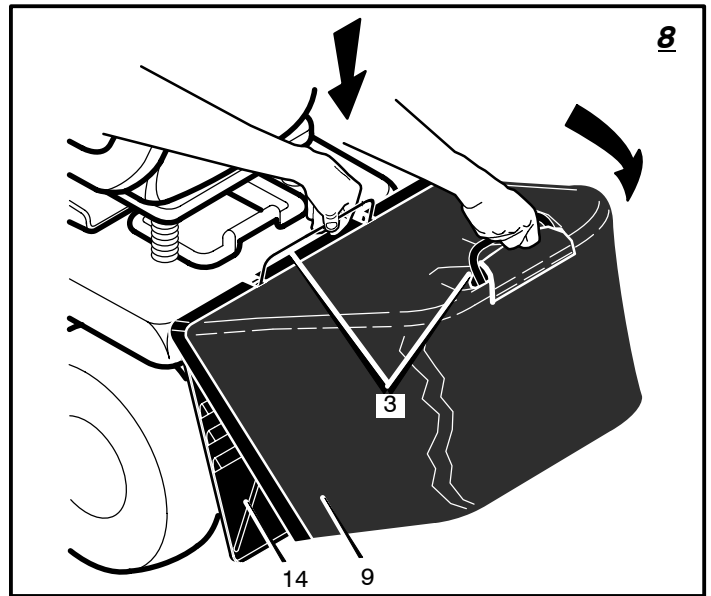
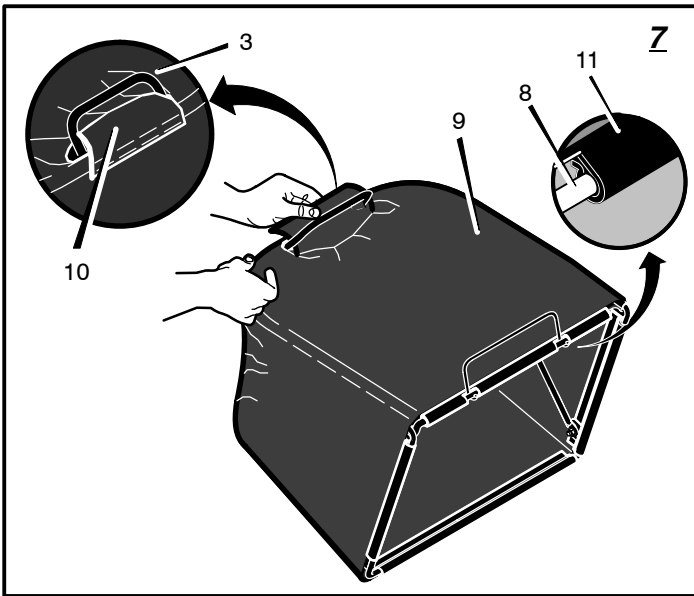

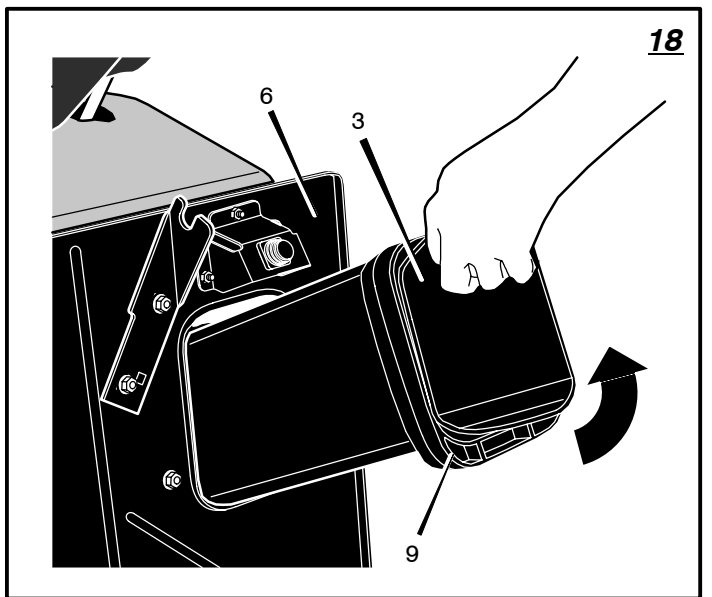
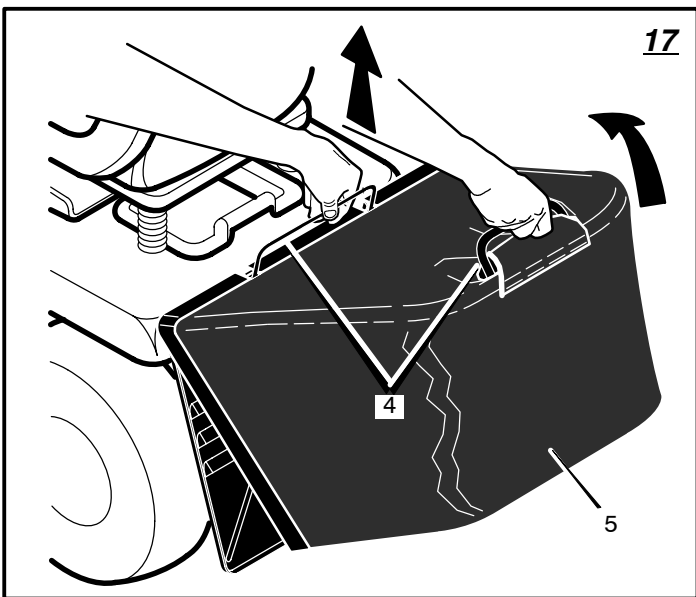
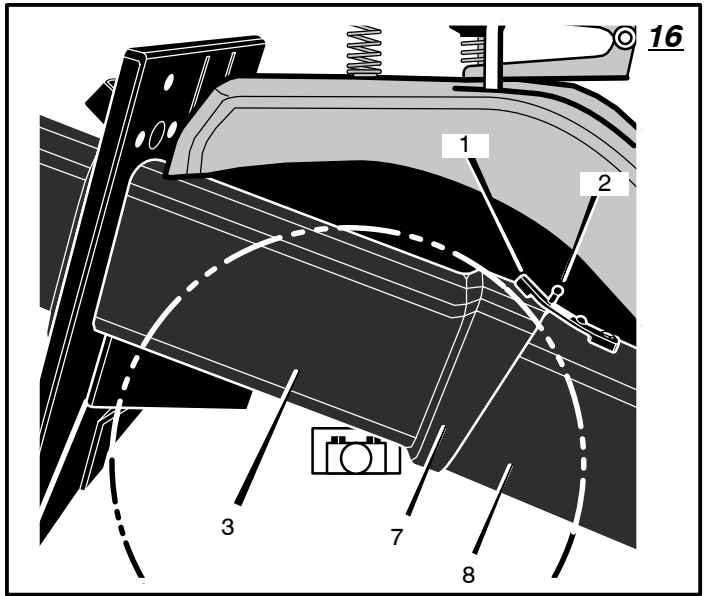
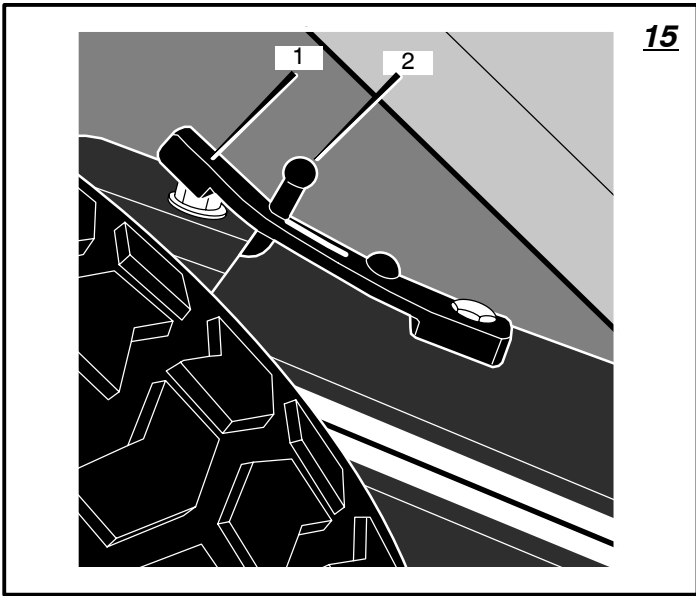
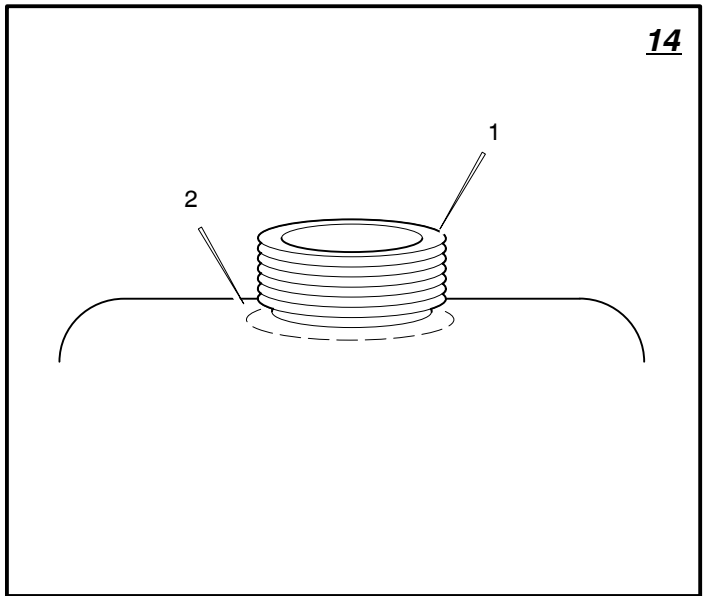
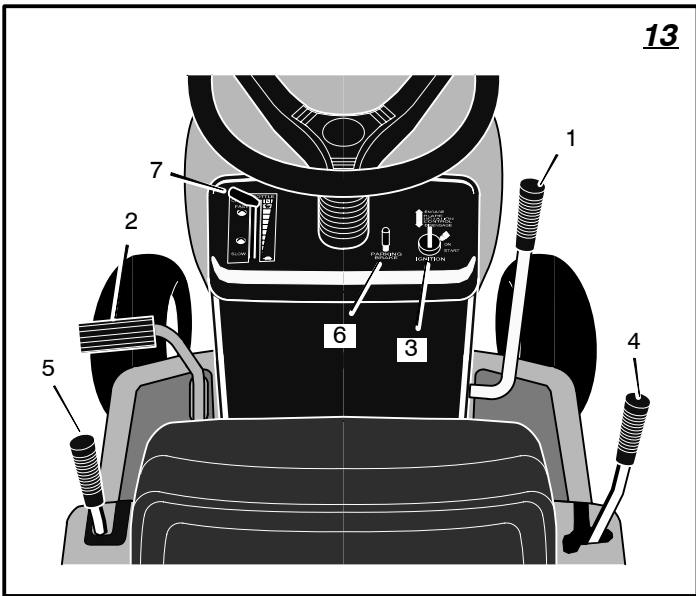

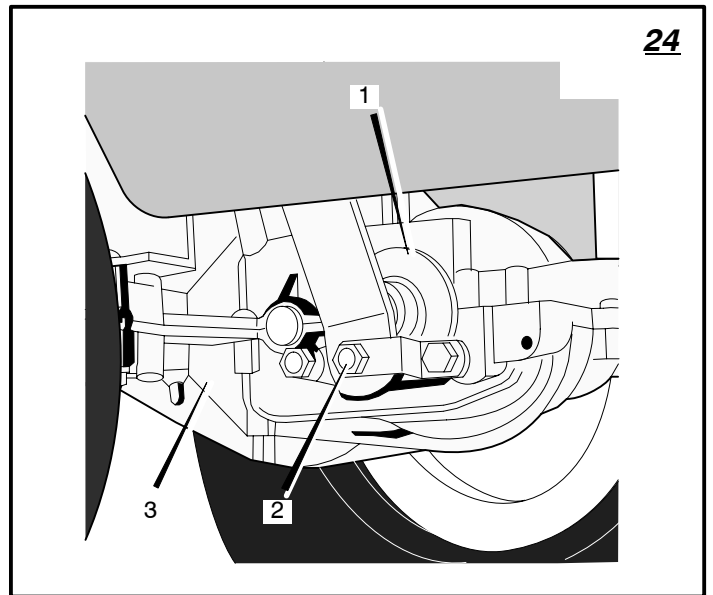
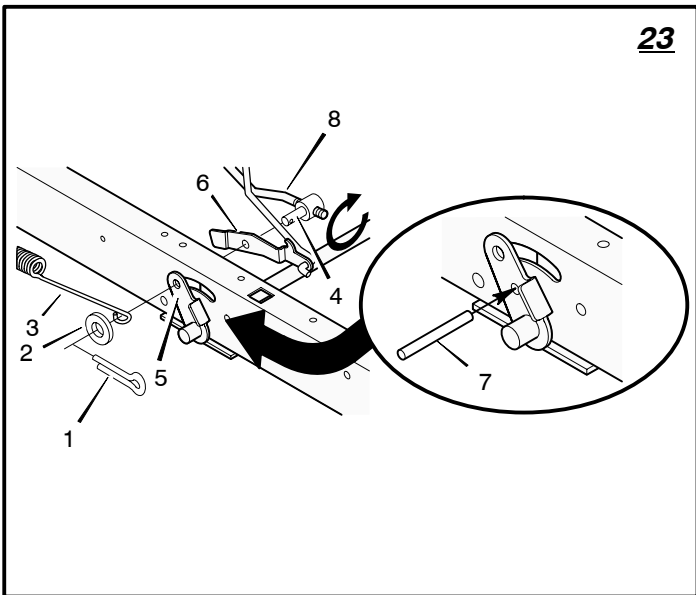
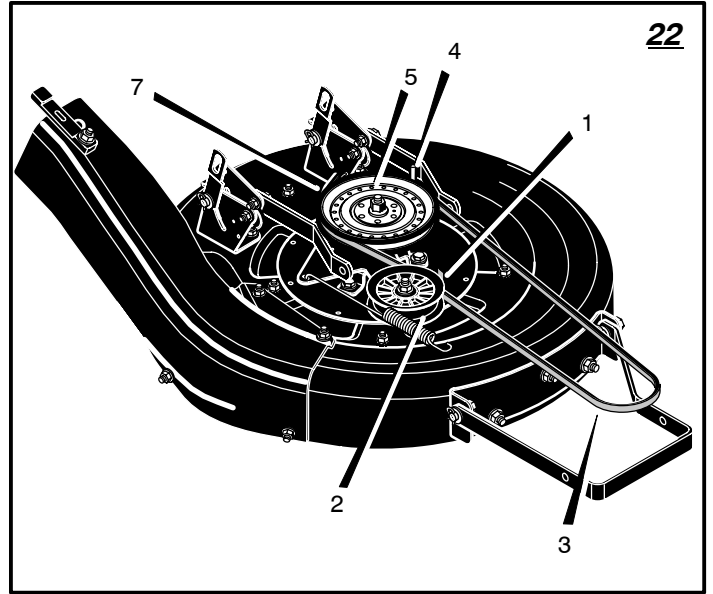
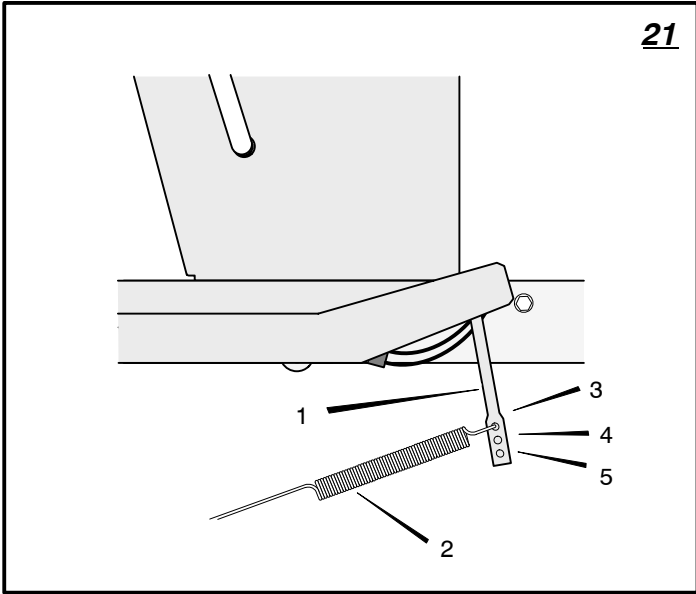
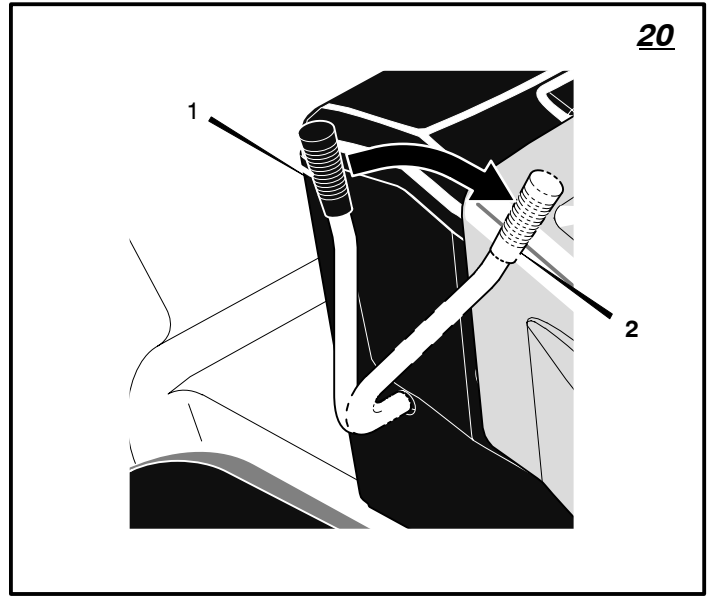
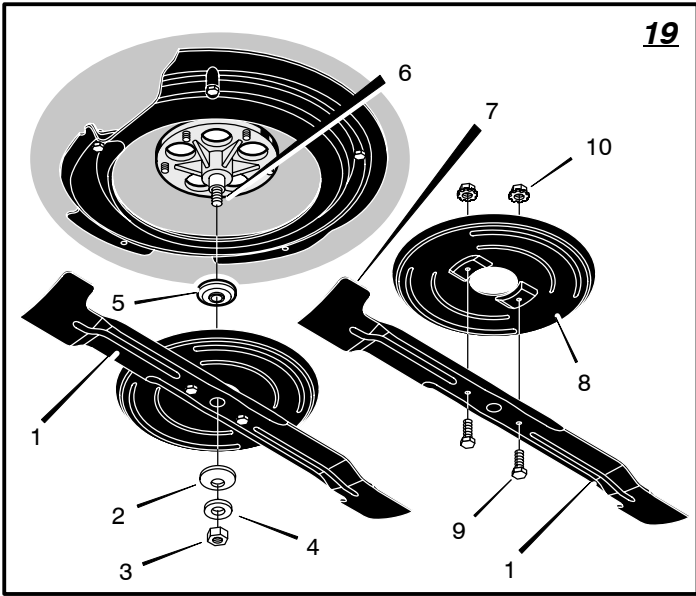

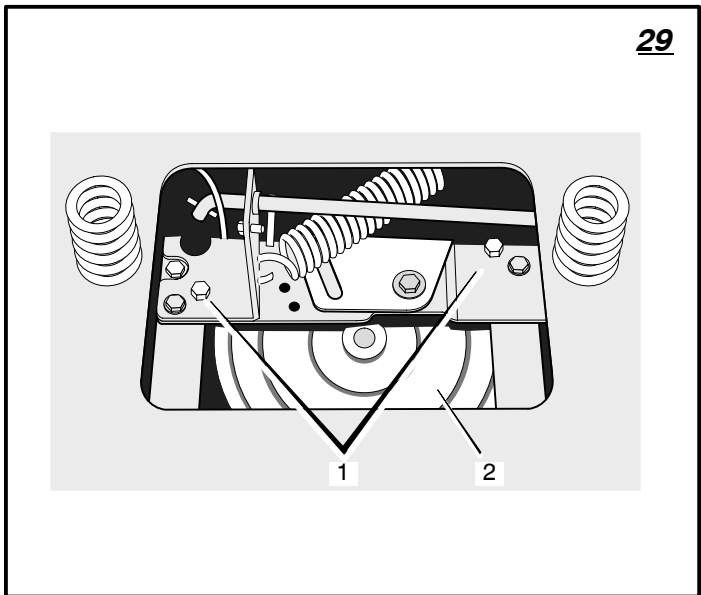
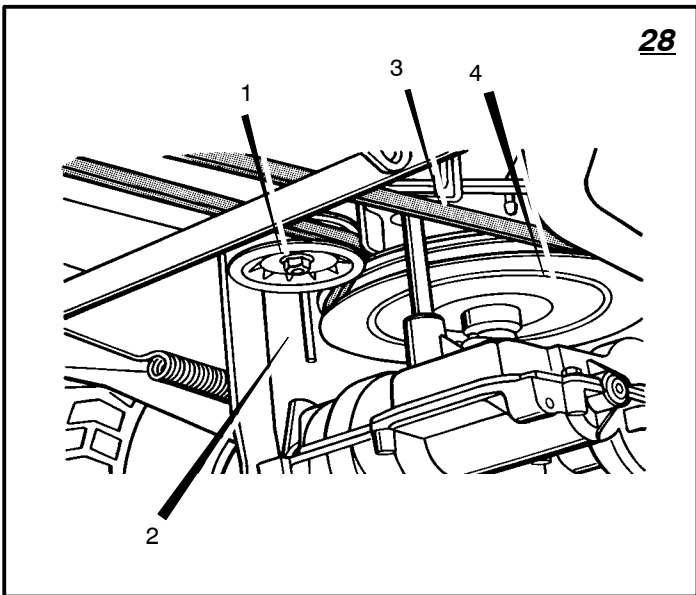
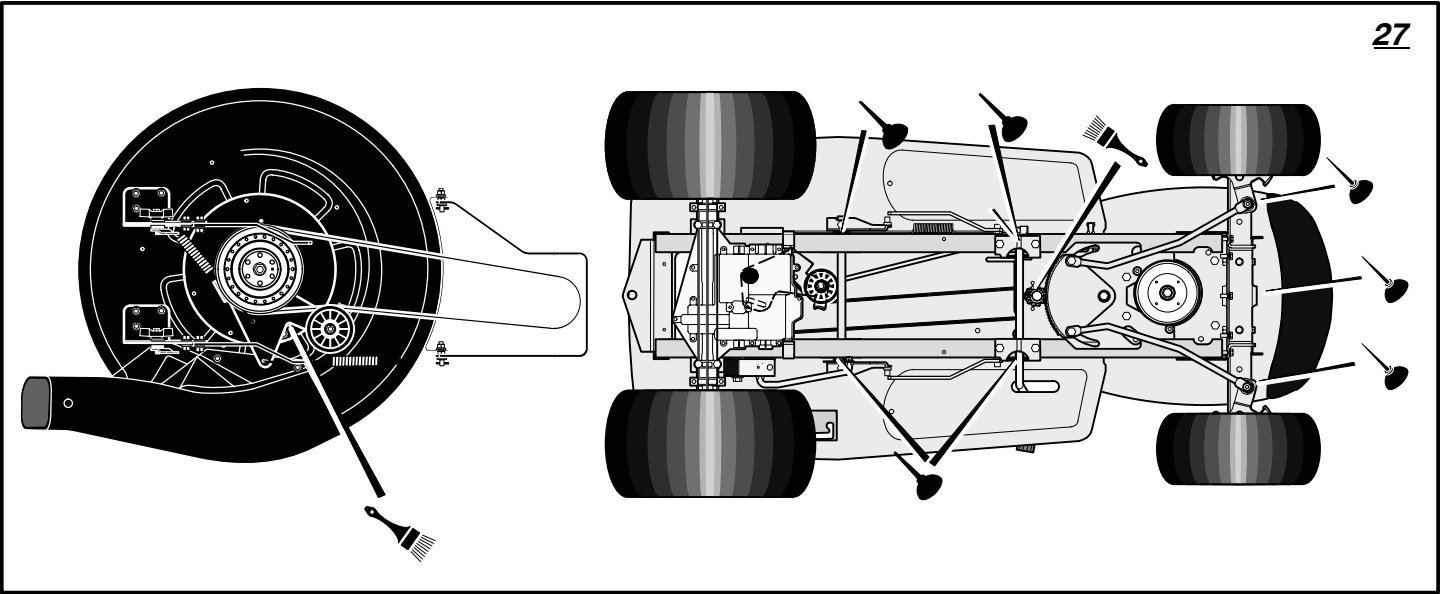
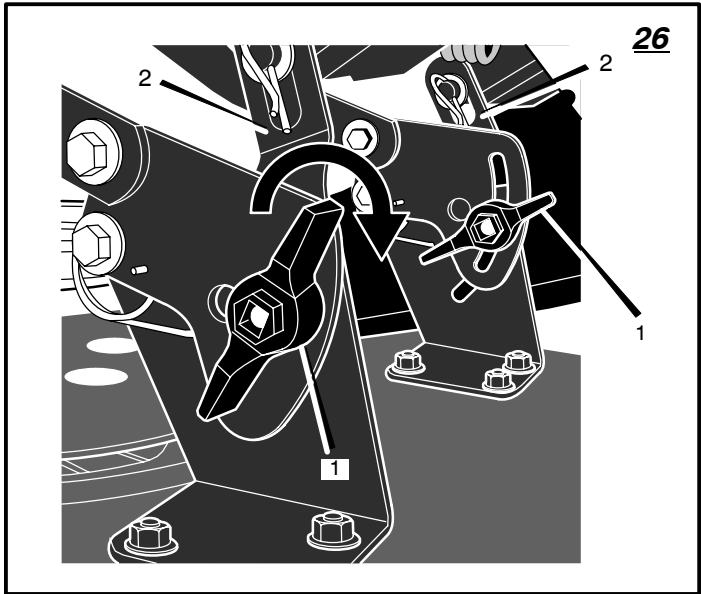
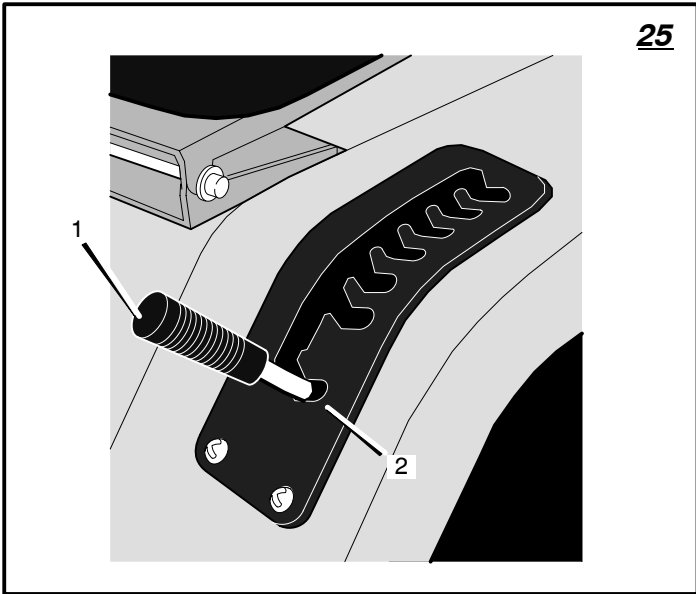

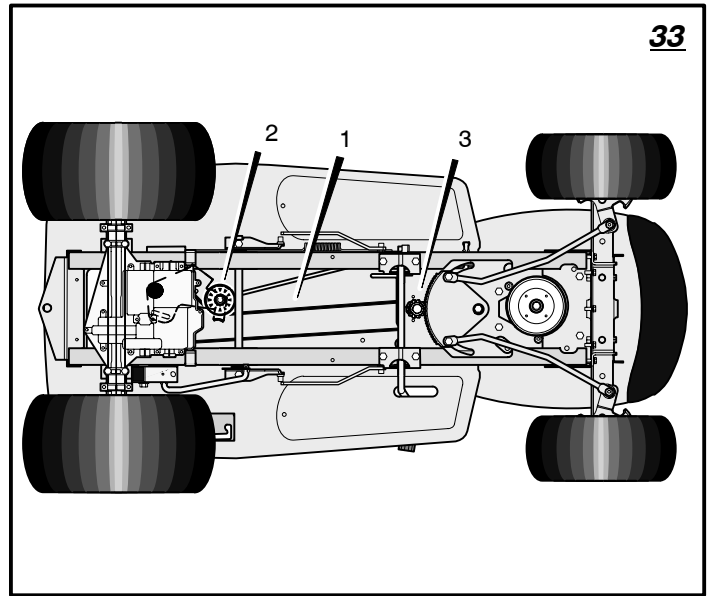
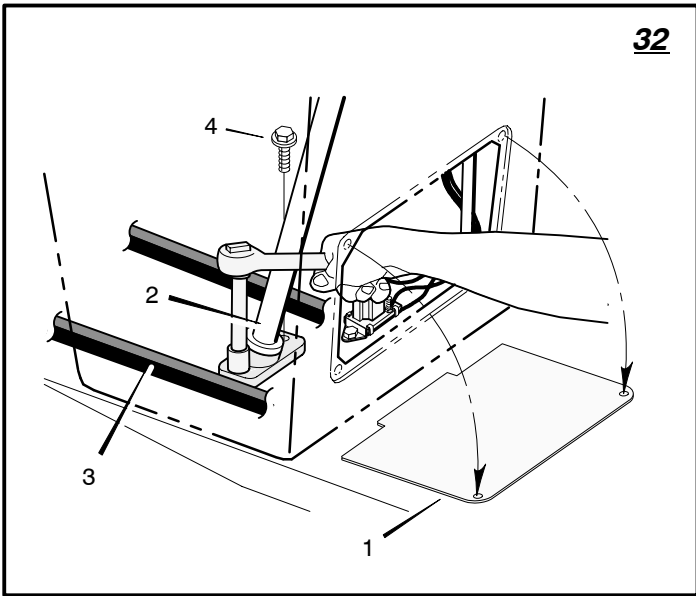
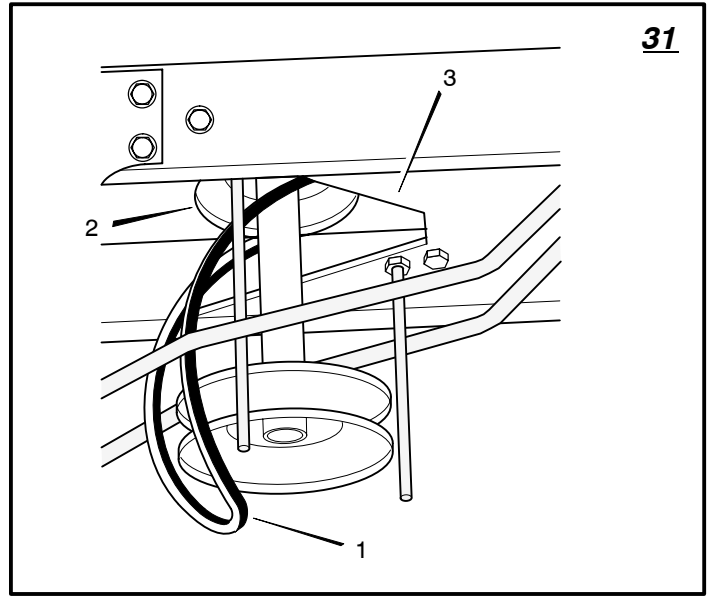
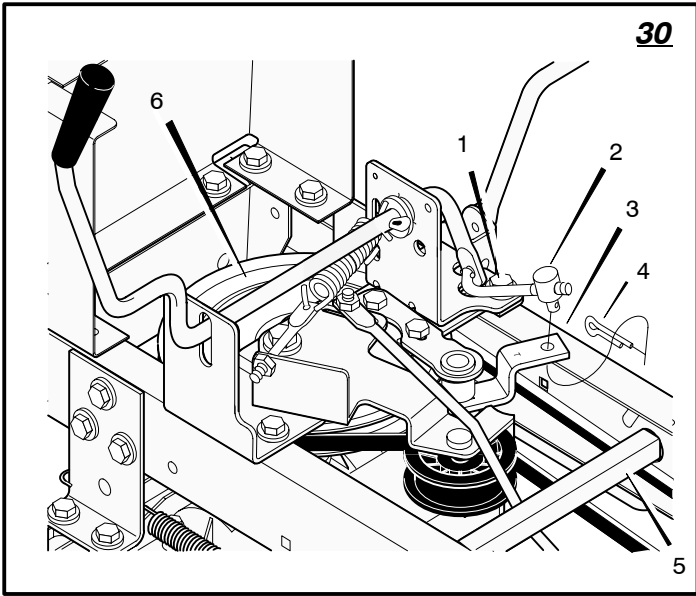

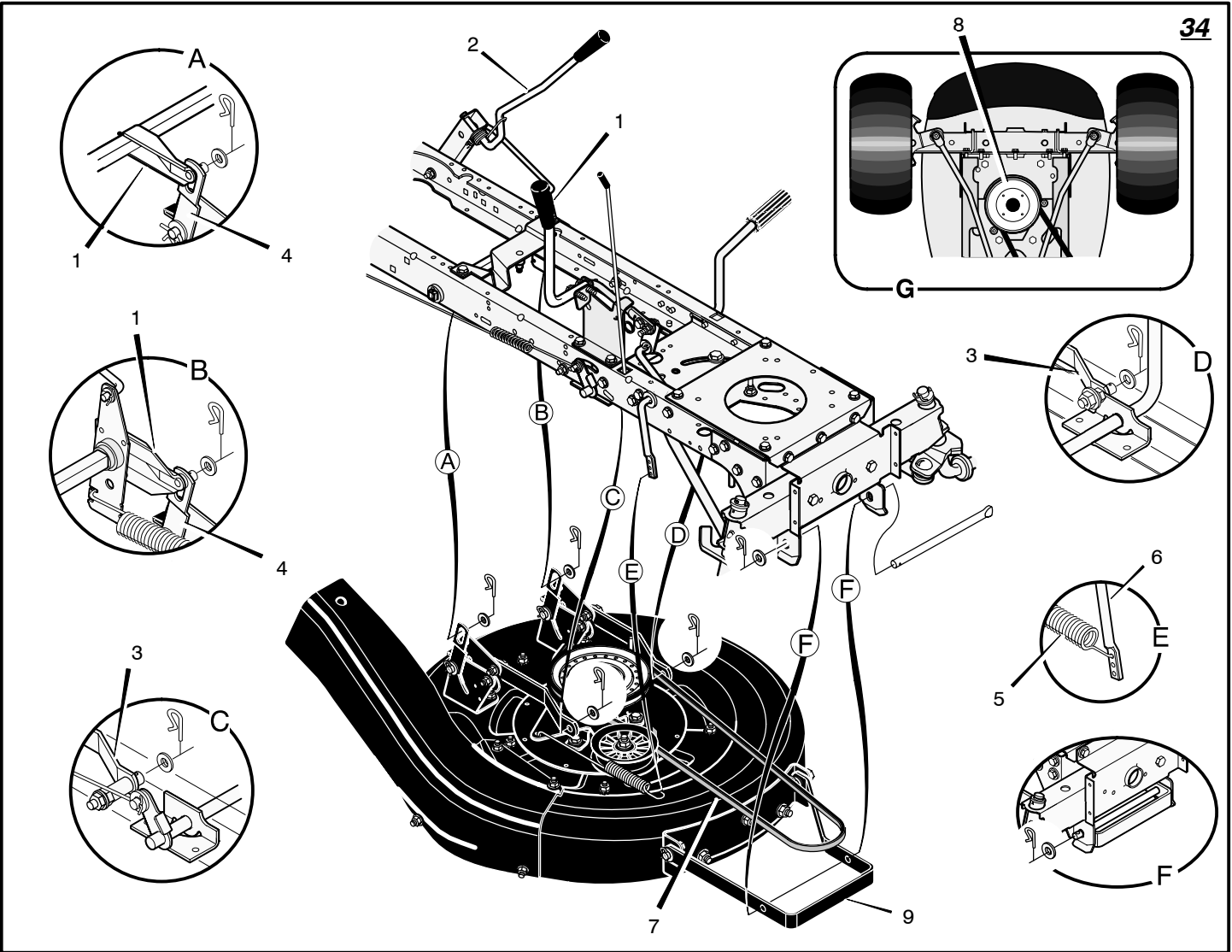

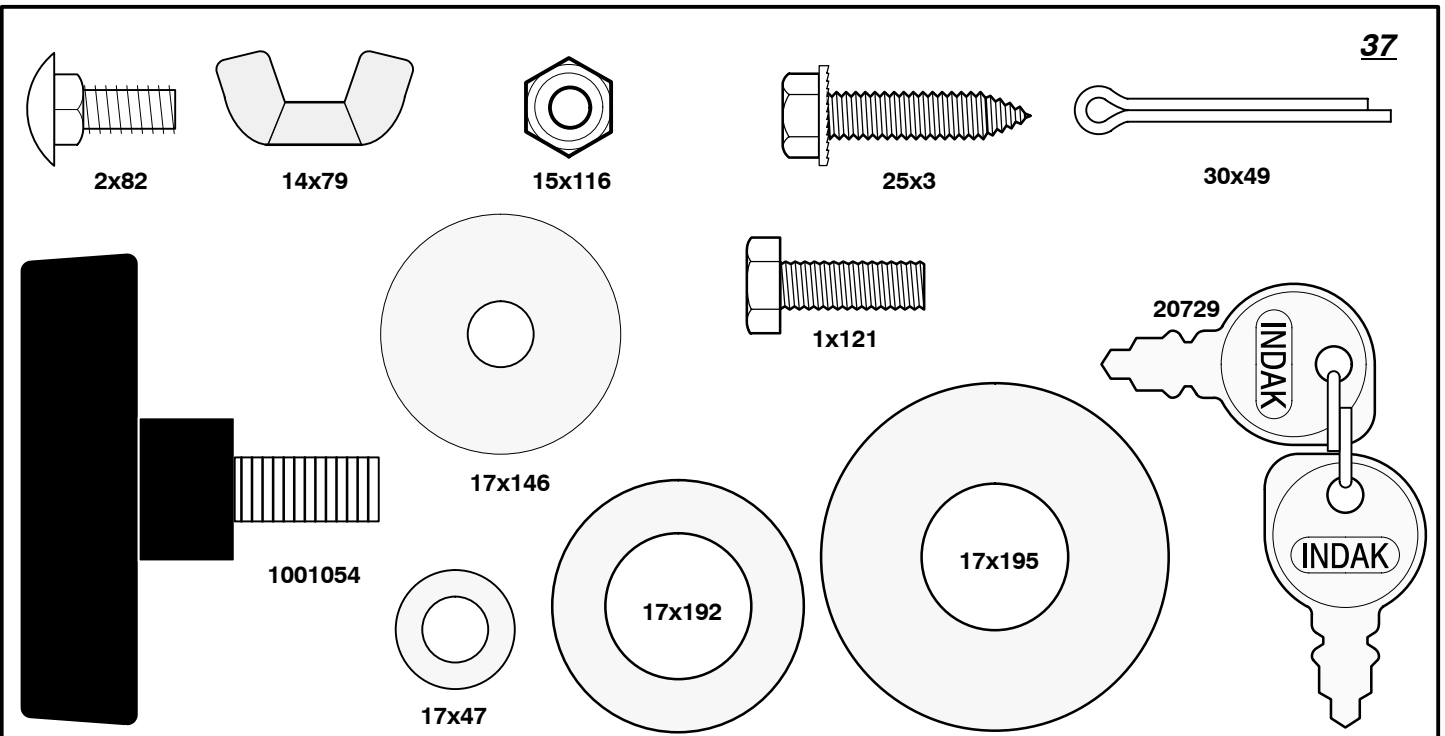
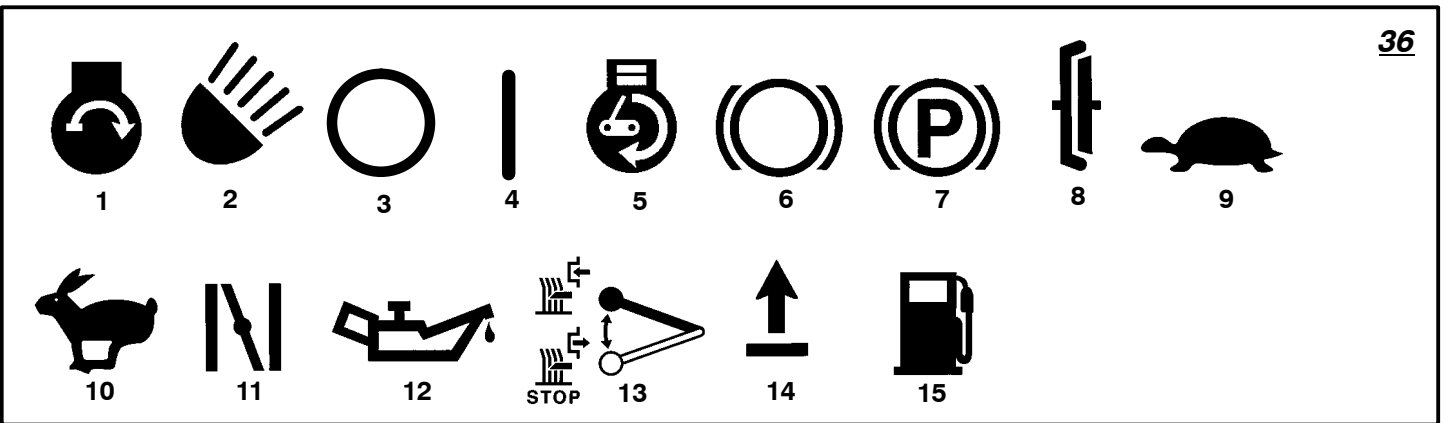
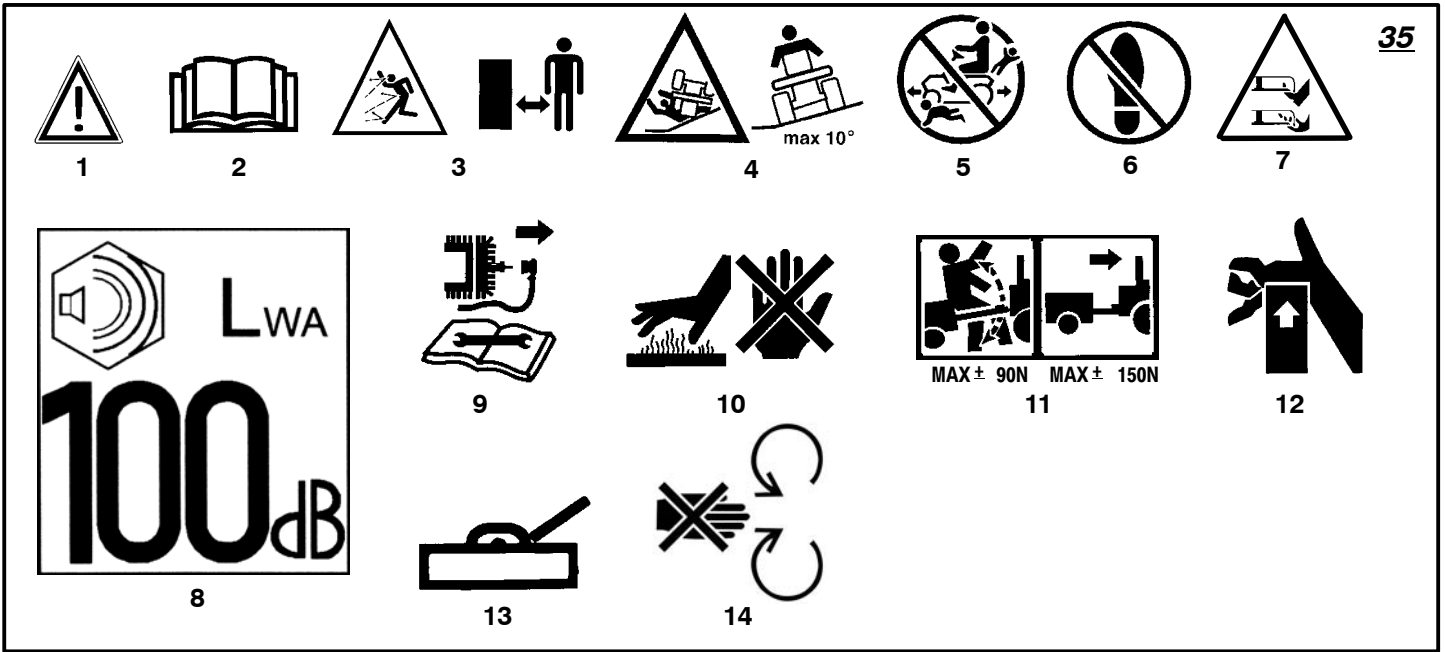

LIMITED WARRANTY

Hayter Limited warrants to the original user / purchaser that this unit shall be free from defects in material and workmanship under normal use and service for a period of **three years** from the date of purchase. The manufacturers of the engine and battery pack system (where applicable) furnish their own warranty and services are provided through their authorised network (Refer to "Engine/Battery Pack Warranty Statement"). To qualify for the full benefit of the warranty, the warranty registration card must be returned within 60 days of purchase. Subject to the conditions and exclusions noted in this limited warranty, we shall at our option, repair or replace any warranted part during the applicable period. If you are in doubt or experience any difficulty, please consult a **Hayter** Authorised Service Dealer for clarification..

To qualify for the extended warranty (second and third year) of the three year limited warranty, the machine must have annual services carried out by an Authorised Hayter Service Dealer. These chargeable services should be carried out within 12 and 24 months of the date of purchase.

Excluded from the extended warranty period are those items which are subject to normal wear and tear e.g. tyres, wheels, cutterbars, cables, batteries and other consumable wearing parts.

All consumer machines which are fitted with a **genuine** Hayter friction disc as original equipment, before use, are covered by a **Lifetime Warranty** against the engine crankshaft bending. **Note:** friction washers, blade brake units and other such devices are not applicable. Only machines fitted with a **genuine** Hayter friction disc, which are used in accordance with the recommended operating and maintenance procedures, are covered.

This warranty does not apply to any unit that has been tampered with, altered, misused, abused or used for hire, and will become invalid if non genuine Hayter parts are fitted. This warranty does not cover minor mechanical adjustments unless they are due to defective materials or workmanship. Consult the Owner's Handbook or a Hayter Authorised Service Dealer for assistance when making these adjustments.

A warranty period of 90 days applies to machines used for commercial purposes.

To make a warranty claim, return the unit to a **Hayter** authorised dealer along with proof of purchase stating the machine serial number and date of purchase. The service receipt(s) or this Owner's Handbook with the 1st/2nd year service boxes fully completed, must be produced as proof of entitlement to the extended warranty period. Subject to the conditions and exclusions in this limited warranty, the authorised dealer will, at our option, repair or replace any warranted part within the duration of the warranty period.

This limited warranty gives you specific legal rights and is in addition to any statutory rights to which you may be entitled and your statutory rights are not affected by this warranty. If you need additional information concerning this written warranty, or assistance in obtaining services, please write to:

HAYTER LIMITED, Service Department, Spellbrook, Bishop's Stortford, Hertfordshire. CM23 4BU.

UK ONLY: Details of your local **Hayter** authorised dealer are contained in Yellow Pages or contact: Freephone 0800 616298.

1st
Year
Service
Record

DEALER STAMP

2nd
Year
Service
Record

DEALER STAMP

Date
Signed

Date
Signed

CONTENTS

LIMITED WARRANTY	10
INTERNATIONAL PICTORIALS	11
OWNER'S INFORMATION	12
SAFE OPERATION PRACTICES	12
ASSEMBLY	13
OPERATION	14
MAINTENANCE	15
TROUBLE SHOOTING CHART	19

INTERNATIONAL PICTORIALS

IMPORTANT: The following pictorials are located on your unit or on literature supplied with the product. Before you operate the unit, learn and understand the purpose for each pictorial.

NOTE: Illustrations and pictorials begin on page 2.

Safety Warning Pictorials (Figure 35)

- 1 WARNING
- 2 IMPORTANT: Read Owner's Manual Before Operating This Machine.
- 3 WARNING: Thrown Objects. Keep Bystanders Away. Read User Instructions Before Operating This Machine.
- 4 WARNING: Do Not Use This Machine On Slopes Greater Than 10 Degrees.
- 5 DANGER: Keep People, Especially Children, Away From Unit.

- | | |
|--|-----------------|
| 6 DANGER: No Step. | 2 Lights |
| 7 DANGER: Keep Feet And Hands Away From Rotating Blade. | 3 Engine Run |
| 8 Declared airborne sound power level of 100 dB(A) is in accordance with Directive 2000/14/EC. | 4 Engine Stop |
| 9 DANGER: Disconnect Spark Plug Wire Before Servicing Unit. | 5 Engine Run |
| 10 WARNING: Hot Surface. | 6 Brake |
| 11 WARNING: Use Caution When Connecting Or Disconnecting Accessories. | 7 Parking Brake |
| 12 WARNING: Crushed Fingers. | 8 Clutch |
| 13 IMPORTANT: Follow Instructions In Owner's Manual To Level The Deck. | 9 Slow |
| 14 WARNING: Stay Clear Of Mower Blade As Long As Engine Is Running. | 10 Fast |
- Control And Operating Pictorials (Figure 36)**
- | | |
|----------------|---------------------------|
| 1 Engine Start | 11 Choke |
| | 12 Oil |
| | 13 Blade Rotation Control |
| | 14 Raise |
| | 15 Fuel |



Declared vibration emission values in accordance with Directive 98/37/EC.

Vibration Emission according to BS EN 1032: Seat 1,3 m/s²,

Right Running Board 0,73 m/s², Left Running Board 1,04 m/s²

Vibration Emission according to BS EN 1033: Steering Wheel 1,82 m/s²

Values determined with operator in operating position when the machine was operated stationary on a concrete surface at 2600 min⁻¹.

Declared airborne noise emissions in accordance with Directive 2000/14/EC, Annex VIII.

Sound Pressure Level at operator position 85 dB.

Values determined at ear according to the specifications of EN ISO 11201.

OWNER'S INFORMATION

Know your product: If you understand the unit and how the unit operates, you will get the best performance. As you read this manual, compare the illustrations to the unit. Learn the location and the function of the controls. To help prevent an accident, follow the operating instructions and the safety rules. Keep this manual for future reference.



WARNING: Look for this symbol to indicate important safety precautions. This symbol indicates: "Attention! Become Alert! Your Safety Is At Risk."

Responsibility Of The Owner



WARNING: This cutting machine is capable of amputating hands and feet and throwing objects. Failure to observe the following safety instructions could result in serious injury or death to the operator or bystanders.

The responsibility of the owner is to follow the instructions below.

SAFE OPERATION PRACTICES

For Ride-On (Riding) Rotary Mower Machines

Training

1. Read the instructions carefully. Be familiar with the controls and the proper use of the equipment.
2. Never allow children or people unfamiliar with these instructions to use the mower. Local regulations may restrict the age of the operator.
3. Never mow while people, especially children, or pets are nearby.
4. Keep in mind that the operator or user is responsible for accidents or hazards occurring to other people or their property.
5. Do not carry passengers.
6. All drivers should seek and obtain professional and practical instruction. Such instruction should emphasize:
 - a. the need for care and concentration when working with ride-on machines;
 - b. control of a ride-on machine sliding on a slope will not be regained by the application of the brake. The main reasons for loss of control are:
 - insufficient wheel grip;
 - being driven too fast;
 - inadequate braking
 - the type of machine is unsuitable for its task;
 - lack of awareness of the effect of ground conditions, especially slopes;
 - incorrect hitching and load distribution.

Preparation

1. While mowing, always wear substantial footwear and long trousers. Do not operate the equipment when barefoot or wearing open sandals.

2. Thoroughly inspect the area where the equipment is to be used and remove all objects which may be thrown by the machine.
3. **WARNING – Petrol is highly flammable.**
 - a. Store fuel in containers specifically designed for this purpose.
 - b. Refuel outdoors only and do not smoke while refuelling.
 - c. Add fuel before starting the engine. Never remove the cap of the fuel tank or add petrol while the engine is running or when the engine is hot.
 - d. If petrol is spilled, do not attempt to start the engine but move the machine away from the area of spillage and avoid creating any source of ignition until petrol vapours have dissipated.
 - e. Replace all fuel tanks and container caps securely.
4. Replace faulty silencers.
5. Before using, always visually inspect to see that the blades, blade bolts and cutter assembly are not worn or damaged. Replace worn or damaged blades and bolts in sets to preserve balance.
6. On multi-blade machines, take care as rotating one blade can cause other blades to rotate.

Operation

1. Do not operate the engine in a confined space where dangerous carbon monoxide fumes can collect.
2. Mow only in daylight or in good artificial light.
3. Before attempting to start the engine, disengage all blade attachment clutches and shift into neutral.
4. Do not use on slopes of more than 10 degrees.
5. Remember there is no such thing as a "safe" slope. Travel on grass slopes requires particular care. To guard against overturning:
 - a. do not stop or start suddenly when going up or downhill;
 - b. engage clutch slowly, always keep machine in gear, especially when travelling downhill;
 - c. machine speeds should be kept low on slopes and during tight turns;
 - d. stay alert for humps and hollows and other hidden hazards;
 - e. never mow across the face of the slope, unless the mower is designed for this purpose.
6. Use care when pulling loads or using heavy equipment.
 - a. Use only approved drawbar hitch points.
 - b. Limit loads to those you can safely control.
 - c. Do not turn sharply. Use care when reversing.
 - d. Use counterweight(s) or wheel weights when suggested in the Instruction Book.
7. Watch out for traffic when crossing or near roadways.
8. Stop the blades rotating before crossing surfaces other than grass.
9. When using any attachments, never direct discharge of material toward bystanders nor allow anyone near the machine while in operation.
10. Never operate the mower with defective guards or shields, or without safety protective devices in place.
11. Do not change the engine governor settings or overspeed the engine. Operating an engine at excessive speed may increase the hazard of personal injury.
12. Before leaving the operator's position
 - a. disengage the power take-off and lower the attachments;
 - b. change into neutral and set the parking brake;
 - c. stop the engine and remove the key.
13. Disengage drive to attachments, stop the engine, and disconnect the spark plug wire(s) or remove the ignition key
 - a. before cleaning blockages or unclogging chute;
 - b. before checking, cleaning or working on the mower;
 - c. after striking a foreign object. Inspect the mower for damage and make repairs before restarting and operating the equipment;
 - d. if the machine starts to vibrate abnormally (check immediately).
14. Disengage drive to attachments when transporting or not in use.
15. Stop the engine and disengage drive to attachment
 - a. before refuelling;
 - b. before removing the grass catcher;
 - c. before making height adjustment unless adjustment can be made from the operator's position.
16. Reduce the throttle setting during engine run-out and, if the engine is provided with a shut-off valve, turn the fuel off at the conclusion of mowing.
17. Before and when backing, look **behind and down** for small children.
18. Use extra care when approaching blind corners, shrubs, trees or other objects that may obscure vision.

Maintenance and Storage

1. On multi-blade machines, take care as rotating one blade can cause other blades to rotate.
2. When machine is to be parked, stored or left unattended, lower the cutting means unless a positive mechanical lock is used.
3. Keep all nuts, bolts, and screws tight to be sure the equipment is in safe working condition.
4. Never store the equipment with petrol in the tank inside a building where fumes may reach an open flame or spark.
5. Allow the engine to cool before storing in any enclosure.
6. To reduce the fire hazard, keep the engine, silencer, battery compartment and petrol storage area free of grass, leaves, or excessive grease.
7. Check the grass catcher frequently for wear or deterioration.
8. Replace worn or damaged parts for safety.
9. If the fuel tank has to be drained, this should be done outdoors.

ASSEMBLY

All fasteners are in the parts bag. Do not discard any parts or material until the unit is assembled.



WARNING: Before doing any assembly or maintenance to the mower, remove the wire from the spark plug.

NOTE: In this instruction book, left and right describe the location of a part with the operator on the seat.

NOTE: Illustrations and pictorials begin on page 2.

NOTE: To assemble the following loose parts, use the fasteners shown at full size in Figure 37.

How To Install The Front Wheels (Figure 1)

NOTE: Use a piece of wood about 4 feet (1.25 meters) long to raise the front of the tractor. If a piece of wood cannot be found, get another person to help lift the tractor. Be careful, do not let the tractor fall.

1. Raise the front of the tractor. Set a support (block of wood) under the tractor.
2. Make sure the **valve stem (2)** is to the outside of the tractor. Slide the **front wheel (1)** on the **spindle (3)**.
3. Fasten each **front wheel (1)** with **washer (4)**, **washer (7)**, and **cotter pin (5)**. Bend the ends of the **cotter pin (5)** apart to keep the **front wheel (1)** on the **spindle (3)**.
4. After the **front wheels (1)** are installed, lift the tractor from the support. Roll the tractor off of the container.
5. If your tractor has **hub caps (6)**, install the **hub caps (6)**. Make sure the **washers (4)** hold the **hub caps (6)** in place.

Check The Tyres

Check the air pressure in the tyres. Tyres with too much air pressure will cause the unit to ride rough. Also, the wrong air pressure will keep the mower housing from cutting level. The correct air pressure is: Front Tyres 0,97 BAR (14 PSI), Rear Tyres 0,69 BAR (10 PSI). The tyres were over inflated for shipment.

Check The Level Of The Mower Housing

Make sure the level of cut is still correct. After you mow a short distance, look at the area that was cut. If the mower housing does not cut level, see the instructions on "How To Level The Mower Housing" in the Maintenance section of this instruction book.

How To Install The Seat (Figure 2)

1. Carefully remove the plastic bag from the **seat (1)**.
2. Align the holes in the **seat hinge (2)** to the holes in the **seat (1)**. Fasten the **seat (1)** to the **seat hinge (2)** with the **fasteners (4)** and **(5)**.

F-040730L

3. Check the operating position of the **seat (1)**. If the **seat (1)** needs to be adjusted, loosen the two **wing bolts (5)**. Slide the **seat (1)** forward or backward along the **seat adjusting holes (3)**. Tighten the **wing bolts (5)**.

How To Assemble The Steering Wheel (Figure 3)

1. Make sure the front wheels point forward.
2. Slide the **cover (3)** over the **steering post (2)**. Make sure the collar of the **cover (3)** is on top.
3. Slide the **steering wheel (1)** onto the **steering post (2)**.
4. Attach the **steering wheel (1)** to the **steering post (2)** with **screw (4)** and **washer (6)**.
5. Some models have an **optional insert (7)** in the parts bag. Attach the **insert (7)** to the center of the **steering wheel (1)**.

How To Assemble The Grass Bag

1. (Figure 5) Slide the **top tube (1)** onto the **wire frame (2)**. Make sure the **handles (3)** on the **top tube (1)** and the **wire frame (2)** are on top.
2. Attach the **struts (4)** to the **INSIDE** of the **mounting tabs (5)** with **bolt (6)** and **nut (7)**. Make sure the head of **bolt (6)** is on the outside and **nut (7)** is locked against the **strut (4)**.
3. (Figure 6) Slide the **frame assembly (8)** into the **grass bag (9)**. Make sure the **Velcro flap (10)** is on top.
4. (Figure 7) Open the **Velcro flap (10)**. Slide the **handle (3)** through the opening and secure the **Velcro flap (10)** under the **handle (3)**.
5. Attach the **clips (11)** to the **frame assembly (8)**.

How To Mount The Grass Bag

1. (Figure 8) To lift the grass bag assembly, use the **grass bag handles (3)**.
2. (Figure 9) Mount the top of the **grass bag assembly (12)** onto the **rear plate hinges (13)**.
3. (Figure 8) When mounting the top of the **grass bag (9)**, hold the bottom of the **grass bag (9)** slightly away from the **rear plate (14)**.
4. (Figure 10) Then, lower the **grass bag (9)** until the bottom is against the rear plate.
5. (Figure 9) Push down on the rear handle. A **locking spring (15)** on the rear plate will secure the bottom of the **grass bag assembly (12)**.

Maintenance Free Battery (Figure 4)

IMPORTANT: Before you attach the battery cables to the battery, check the battery date. The battery date tells if the battery must be charged.

1. Check the top of the **battery (1)** for the location of the battery date.
2. If the **battery (1)** is put into service *before* the battery date, the battery cables can be attached without charging the **battery (1)**. See "How To Install The Battery Cables".

3. If the **battery (1)** is put into service *after* the battery date, the **battery (1)** must be charged. See "How To Charge The Maintenance Free Battery".

How To Charge The Battery (Figure 4)



WARNING: When you charge the battery, do not smoke. Keep the battery away from any sparks. The fumes from the battery acid can cause an explosion.

1. Remove the **battery (1)** and **battery tray (3)**.
2. Remove the protective caps from the battery terminals.
3. Use a 12 volt battery charger to charge the **battery (1)**. Charge at a rate of 6 amperes for one hour. If you do not have a battery charger, have an authorized service centre charge the battery.
4. Install the **battery (1)** and **battery tray (3)**. Make sure the **positive (+) terminal (4)** is on the left side.

How To Install The Battery Cables (Figure 4)



WARNING: To prevent sparks, fasten the red cable to the positive (+) terminal before you connect the black cable.

1. Remove the protective caps from the battery terminals.
2. Slide the **terminal cover (2)** onto the **red cable (5)**. Fasten the **red cable (5)** to the **positive (+) terminal (4)** with the **fasteners (6)** and **(7)**.
3. Fasten the **black cable (8)** to the negative (-) terminal with the **fasteners (6)** and **(7)**.

How To Prepare The Engine

NOTE: The engine was shipped from the factory filled with oil. Check the level of the oil. Add oil as needed.

See the engine manufacturer's instructions for the type of petrol and oil to use. Before you use the unit, read the information on safety, operation, maintenance, and storage.



WARNING: Follow the engine manufacturer's instructions for the type of petrol and oil to use. Always use a safety petrol container. Do not smoke when adding petrol to the engine. When inside an enclosure, do not fill with petrol. Before you add petrol, stop the engine. Let the engine cool for several minutes.

Important! Before You Start Mowing

- Check the engine oil.
- Fill the fuel tank with petrol.
- Check the level of the mower housing.
- Check the air pressure of the tyres.
- Attach the battery cables.

OPERATION

NOTE: Illustrations and pictorials begin on page 2.

Location Of Controls (Figure 13)

Blade Rotation Control (1): Use the blade rotation control to start and stop the rotation of the blade.

Clutch / Brake Pedal (2): The pedal has two functions. The first function is a clutch. The second function is a brake.

Headlight Switch (3): The headlight switch is the first part of the ignition switch. To use the lights with the engine running, turn the key to the position for the lights.

Ignition Switch (3): Use the ignition switch to start and stop the engine.

Shift Lever (4): Use the shift lever to change the speed of the unit.

Lift Lever (5): Use the lift lever to change the height of cut.

Parking Brake Lever (6): Use the parking brake lever to engage the brake when you leave the unit.

Throttle Control Lever (7): Use the throttle control lever to increase or decrease the speed of the engine.

How To Use The Throttle Control (Figure 13)

Use the **throttle control (7)** to increase or decrease the speed of the engine.

1. The FAST position is marked with a detent. For normal operation and when using a grass bagger, move the throttle control to the FAST position. For maximum charging of the battery and for a cooler running engine, operate the engine in the FAST position.
2. The engine governor is set at the factory for maximum performance. Do not adjust the governor to increase the speed of the engine.

How To Use The Blade Rotation Control (Figure 13)

Use the **blade rotation control (1)** to engage the blade(s).

1. Before you start the engine, make sure the **blade rotation control (1)** is in the DISENGAGE position.
2. Move the **blade rotation control (1)** to the ENGAGE position to rotate the blade(s).

NOTE: If the engine stops when you engage the blade(s), the seat switch or the grass bag switch is not activated.

3. Move the **blade rotation control (1)** to the DISENGAGE position to stop the blade(s). Before you leave the operator's position, make sure the blade(s) has stopped rotating.
4. Before you ride the unit across a sidewalk or a road, move the **blade rotation control (1)** to the DISENGAGE position.



WARNING: Always keep your hands and feet away from the blade, deflector opening, and the mower housing when the engine runs.

How To Use The Shift Lever (Figure 13)

To change the forward speed or the direction of the unit, follow the steps below.

CAUTION: Before you move the shift lever, completely push the clutch/brake pedal forward to stop the unit. If the unit is not stopped, the gearbox can be damaged.

1. Completely push the **clutch/brake pedal (2)** forward to stop the unit. Keep your foot on the pedal.
2. Move the **throttle control lever (7)** to the SLOW position.
3. To go forward, move the **shift lever (4)** to a forward speed setting. To go backward, move the **shift lever (4)** to reverse.
4. Slowly release the **clutch/brake pedal (2)**. Do not keep your foot on the pedal.
5. Move the **throttle control (7)** to the FAST position.

How To Use The Parking Brake (Figure 13)

1. Completely push the **clutch/brake pedal (2)** forward.
2. Lift the **parking brake lever (6)**.
3. Remove your foot from the **clutch/brake pedal (2)** and then release the **parking brake lever (6)**. Make sure the parking brake will hold the unit.
4. To release the **parking brake (6)**, completely push the **clutch/brake pedal (2)** forward. The parking brake will automatically release.



WARNING: Before you leave the operator's position, move the shift lever to the neutral (N) position. Set the parking brake. Move the blade rotation control to the DISENGAGE position. Stop the engine and remove the ignition key.

How To Change The Cutting Height (Figure 13)

To change the cutting height, raise or lower the **lift lever (5)** as follows.

1. Move the **lift lever (5)** forward to lower the mower housing and back to raise the mower housing.
2. When you ride on a sidewalk or road, move the **lift lever (5)** to the highest position and move the **blade rotation control** to the DISENGAGE position.

How To Stop The Unit (Figure 13)

1. Completely push the **clutch/brake pedal (2)** forward to stop the unit. Keep your foot on the pedal.
2. Move the **blade rotation control (1)** to the DISENGAGE position.
3. Move the **shift lever (4)** to the NEUTRAL position.
4. Set the **parking brake (6)**.



WARNING: Make sure the parking brake will hold the unit.

5. Move the **throttle control (7)** to the SLOW position.
6. To stop the engine, turn the **ignition key (3)** to the OFF position. Remove the key.

How To Transport The Unit

To transport the unit, follow the steps below.

1. Move the blade rotation control to the DISENGAGE position.
2. Raise the lift lever to the highest position.
3. Move the throttle control to a position between SLOW and FAST.
4. To go faster, move the shift lever to a faster speed.

How To Operate With The Mower Housing

IMPORTANT: When you operate with the mower housing, always operate with the throttle control in the FAST position.

1. Start the engine.
 2. Move the lift lever to a height of cut position. In high or thick grass, cut the grass in the highest position first and then lower the mower housing to a lower position.
 3. Move the throttle control to the SLOW position.
 4. Slowly move the blade rotation control to the ENGAGE position.
 5. Push the clutch/brake pedal completely forward.
 6. Move the shift lever to one of the speed settings.
- NOTE:** When you mow in heavy grass or mow with a bagger, put the shift lever in the slowest speed.
7. Slowly release the clutch/brake pedal.
 8. Move the throttle control to the FAST position. If you need to go faster or slower, stop the unit and move the shift lever to another speed setting.
 9. Make sure the level of cut is still correct. After you mow a short distance, look at the area that was cut. If the mower housing does not cut level, see the instructions on "How To Level The Mower Housing" in the Maintenance section.



WARNING: For better control of the unit, select a safe speed.

How To Operate On Hills



WARNING: Do not ride up or down slopes that are too steep to back straight up. Never ride the unit across a slope.

1. Before you ride up or down a hill, move the shift lever to the slowest speed.
2. Do not stop or change speed settings on a hill. If you must stop, quickly push the clutch/brake pedal forward and set the parking brake.
3. To start again, make sure the shift lever is in the slowest speed. Move the throttle control to the SLOW position. Slowly release the pedal.

4. If you must stop or start on a hill, always have enough space for the unit to roll when you release the brake and engage the clutch.
5. Be very careful when you change directions on a hill. When on a slope or in a turn on a hill, move the throttle control to the SLOW position to help prevent an accident.

How To Use The Grass Bagger



WARNING: Do not ride up or down slopes that are too steep to back straight up. Never ride the unit across a slope.

Operation

To operate with the grass bagger, follow the steps below.

1. Start the engine.
2. Move the throttle control to FAST position.
3. Move the shift lever to FIRST (1) position. To fill the grass bag, always operate at the slowest speed.
4. If the height of the grass is more than 3¹/₂ inches (9cm), cut the grass with the mower housing in the highest position. Then, lower the mower housing and cut the grass again. You can also cut at 1/2 to 2/3 of the full cutting width of the mower housing.

How To Clear The Connector Tube And The Extension Tube

If the **connector tube** or the **extension tube** becomes filled with grass, clear as follows.

1. Move the blade rotation control to the DISENGAGE position.
2. Move the shift lever to the neutral (N) position.
3. Engage the parking brake.
4. Stop the engine.
5. **(Figure 8)** Remove the **grass bagger (9)**.
6. **(Figure 11)** Use a long **stick (1)** to push any grass and debris from the **connector tube (2)** or the extension tube.
7. If the connector must be removed, see "How To Remove The Connector Tube" in the maintenance section.

How To Empty The Grass Bagger

1. Move the blade rotation control to the DISENGAGE position.
2. Move the shift lever to the neutral (N) position.
3. Engage the parking brake.
4. **(Figure 12)** Raise the rear of the **grass bag (9)**.

Before Starting The Engine

Check the oil

NOTE: The engine was shipped from the factory filled with oil. Check the level of the oil. Add oil as needed. See the engine manufacturer's instructions for the type of petrol and oil to use.

1. Make sure the unit is level.

NOTE: Do not check the level of the oil while the engine runs.

F-040730L

2. Check the oil. Follow the procedure in the engine manufacturer's instructions.
3. If necessary, add oil until the oil reaches the FULL mark on the dipstick. The quantity of oil needed from ADD to FULL is shown on the dipstick. Do not add too much oil.

Add Petrol



WARNING: Always use a safety petrol container. Do not smoke when adding petrol to the fuel tank. Do not add petrol when you are inside an enclosure. Before you add petrol, stop the engine and let the engine cool for several minutes.

(Figure 14) Fill the **fuel tank (1)** to the **FULL (2)** position with regular unleaded petrol. Do not use premium unleaded petrol. Make sure the petrol is fresh and clean. Leaded petrol will increase deposits and shorten the life of the valves.

How To Start The Engine



WARNING: The electrical system has an operator presence system that includes a sensor switch for the seat. These components tell the electrical system if the operator is sitting on the seat. This system will stop the engine when the operator leaves the seat if the blade rotation control is engaged or if the transmission is engaged. For your protection, always make sure this system operates correctly.

NOTE: The engine will not start unless you depress the clutch/brake pedal or engage the parking brake and move the blade rotation control to the DISENGAGE position.

1. Push the clutch/brake pedal completely forward. Keep your foot on the pedal.
2. Move the shift lever to the neutral (N) position.
3. Make sure the blade rotation control is in the DISENGAGE position.
4. Move the throttle control completely forward to the CHOKE or FAST position. Some models have a separate choke knob. Pull the choke knob to the full CHOKE position.
5. Turn the ignition key to the START position.

NOTE: If the engine does not start after four or five tries, move the throttle control to the FAST position. Again try to start the engine. If the engine will not start, see the TROUBLE SHOOTING CHART.

6. Slowly move the throttle control to the SLOW position.
7. To start a hot engine, move the throttle control to a position between FAST and SLOW.

Mowing And Bagging Tips

1. For a lawn to look better, check the cutting level of the mower housing. See "How To Level The Mower Housing" in the Maintenance section.
2. For the mower housing to cut level, make sure the tyres have the correct amount of air pressure.

3. Every time you use the unit, check the blade. If the blade is bent or damaged, immediately replace the blade. Also, make sure the nut for the blade is tight.
4. Keep the blade(s) sharpened. Worn blades will cause the ends of the grass to turn brown.
5. If the grass is very high, cut two times to decrease the load on the engine. First cut with the mower housing in the highest position and then lower the mower housing for the second cut.
6. Operate the engine with the throttle in FAST position and the shift lever in first or second gear.
7. For better cutting performance and a quality cut, mow with the shift lever in one of the slower speeds.
8. After each use, clean the bottom and top of the mower housing for better performance. Also, a clean mower housing will help prevent a fire.

MAINTENANCE

NOTE: Illustrations and pictorials begin on page 2.

General Recommendations

1. The owner's responsibility is to maintain this product. This will extend the life of the product and is also necessary to maintain warranty coverage.
2. Check the spark plug, drive brake, lubricate the unit, and clean the air filter once a year.
3. Check the fasteners. Make sure all fasteners are tight.
4. Follow the Maintenance section to keep the unit in good operating condition.



WARNING: Before you make an inspection, adjustment, or repair to the unit, disconnect the wire to the spark plug. Remove the wire from the spark plug to prevent the engine from starting by accident.

NOTE: Torque is measured in metric N-m (foot pounds). This measurement describes how tight a nut or bolt must be. The torque is measured with a torque wrench.

How To Remove The Connector Tube

For good bagging performance, the connector tube must be clean and free from grass and debris. Remove and clean the **connector tube** as follows.

To Remove

1. Move the blade rotation control to the DISENGAGE position.
2. Move the shift lever to the neutral (N) position.
3. Engage the parking brake.
4. Stop the engine.
5. Move the lift lever to the middle cutting position.
6. **(Figure 15 and Figure 16)** Disconnect the **rubber strap (1)** from the **latch pin (2)** on the **connector tube (3)**.
7. **(Figure 17)** Hold the **handles (4)**. Remove the **grass bag (5)**.

- (**Figure 18**) Pull the **connector tube (3)** through hole in **rear plate (6)**.
- Clean the **connector tube (3)** with soap and water.

To Install

- (**Figure 16 and Figure 18**) Slide the **flange (7)** end of the **connector tube (3)** through hole in **rear plate (6)**.
- (**Figure 16**) Slide the **flange (7)** end of the **connector tube (3)** over the **extension tube (8)**.
- (**Figure 15 and Figure 16**) Attach the **rubber strap (1)** to the **latch pin (2)** on the **connector tube (3)**.
- Install the grass bag.

Inspect Blade (**Figure 19**)



WARNING: Before you inspect or remove the blade, disconnect the wire to the spark plug. If the blade hits an object, stop the engine. Check the unit for damage. The blade has sharp edges. When you hold the blade, use gloves or cloth material to protect your hands.

If you keep the **blade (1)** sharp and inspect the blade for damage, the blade will cut better and be more safe to operate. Frequently check the blade for excessive wear, cracks, or other damage. Frequently check the **nut (3)** that holds the **blade (1)**. Keep the **nut (3)** tight. If the blade hits an object, stop the engine. Disconnect the wire to the spark plug. See if the blade is bent or damaged. Check the **blade adapter (5)** for damage. Before you operate the unit, replace damaged parts with original equipment parts. See the authorized service centre in your area. Every three years, have an authorized service person inspect the blade or replace the old blade with an original equipment part.

How To Remove And Install The Blade (**Figure 19**)

- Remove the mower housing. See the instructions on "How To Remove The Mower Housing".
- Use a piece of wood to keep the blade from rotating.
- Remove the **nut (3)** that holds the **blade (1)**.
- To remove the **blade (1)** from the **air assist fan (8)**, remove **fasteners (9)** and **(10)**.
- Check the **blade (1)** and the **blade adapter (5)** according to the instructions for "Inspect Blade". Check the **air assist fan (8)** for damage. Replace badly worn or damaged parts with original equipment parts. See an authorized service centre in your area.
- Clean the top and bottom of the mower housing. Clean the **air assist fan (8)**. Remove all the grass and debris.
- Assemble the **blade (1)** and **air assist fan (8)** with **fasteners (9)** and **(10)**. Tighten the **bolt (9)** that holds the **blade (1)** to a torque of 6,8 N-m (5 foot pounds).
- Mount the **blade (1)** and **blade adapter (5)** on the **mandrel (6)**.

- Mount the **blade (1)** so that the **hi-lift edges (7)** are up. If the **blade** is upside down, the **blade** will not cut correctly and can cause an accident.
- Fasten the **blade (1)** with the original washers and **nut (3)**. Make sure the outside rim of the **Belleville washer (2)** is against the **blade (1)**.



WARNING: Always keep the **nut (3)** tight that holds the **blade (1)**. A loose nut or blade can cause an accident.

- Tighten the **nut (3)** that holds the **blade (1)** to a torque of 41,5 N-m (30 foot pounds).
- Install the mower housing. See "How To Remove The Mower Housing".

How To Adjust The Blade Rotation Control



WARNING: To prevent an injury, the blade rotation control must operate correctly.

In normal usage, the blade rotation control will not require an adjustment. However, if the cutting performance decreases or the quality of cut is poor, make the following changes.

- When you mow, make sure the throttle control is in the FAST position.
- (**Figure 20**) Move the blade rotation control to the **DISENGAGE position (1)**.
- Stop the engine. Disconnect the wire from the spark plug.
- Check the blade(s). Keep a sharp edge on the blade(s). A blade that is not sharp will cause the tips of the grass to become brown.
- (**Figure 21**) Disconnect the **blade drive spring (2)** from the **blade control rod (1)**. Move the **blade drive spring (2)** to the **middle hole (4)**. This will increase the tension on the mower drive belt.
- Attach the wire to the spark plug. Mow for a short distance and again check the quality of cut. If necessary, move the **blade drive spring (2)** to the **bottom hole (5)**.
- Again check the quality of cut. If the quality of cut has not improved, replace the mower drive belt. See "How To Replace The Mower Drive Belt". If replacing the belt does not correct the problem, take the unit to an authorized service centre.
- Move the blade rotation control to the **DIS-ENGAGE** position. Stop the engine.
- (**Figure 22**) Check the operation of the blade brake. Rotate the **mandrel pulley (5)** with your hand. Make sure the **brake pad (7)** is pressed tightly against the **mandrel pulley (5)**.



WARNING: If the **brake pad (7)** does not press tightly against the **mandrel pulley (5)**, take the unit to an authorized service centre.

- (**Figure 20**) Move the blade rotation control to the **ENGAGE position (2)**.
- (**Figure 22**) Check the pad for the **blade brake (7)**. If the pad is excessively worn or damaged, replace the brake pad assembly. Correct replacement parts and assistance are available from an authorized service centre.

- Attach the wire to the spark plug. Mow for a short distance and again check the operation of the blade rotation control.
- When you move the blade rotation control to the **DISENGAGE** position, all movement will stop within five seconds. If there is movement of the belt or the blade(s) continue to rotate, engage and disengage the blade rotation control five times to remove any excess rubber from a new mower drive belt. If you need assistance, take the unit to an authorized service centre.
- (**Figure 21**) If you replace the mower drive belt, move the **blade drive spring (2)** to the **top hole (3)**.

How To Adjust The Shift Lever (**Figure 30**)

If the **NEUTRAL** position on the shift lever does not match neutral on the gearbox, adjust the shift lever as follows.

- Stop the engine.
- Disconnect the **adjuster nut (2)** from the **shifter bracket (3)**.
- Make sure the shift lever is in the **NEUTRAL** position.
- Push the unit forward. Make sure the gearbox is in neutral.
- To align the **adjuster nut (2)** with the hole in the **shifter bracket (3)**, turn the **adjuster nut (2)**.
- Connect the **adjuster nut (2)** to the **shifter bracket (3)**.
- Make sure the **NEUTRAL** position on the shift lever matches neutral on the gearbox.

How To Check And Adjust The Clutch (**Figure 23**)

If the motion drive belt is loose, the clutch will slip when: going up a hill, pulling a heavy load, or the unit will not move forward. Adjust the clutch as follows.



WARNING: Before you make an inspection, adjustment, or repair to the unit, disconnect the wire to the spark plug to prevent the engine from starting by accident.

- Check the routing of the motion drive belt. Make sure the belt is installed correctly and is inside all the belt guides.
- Remove the **cotter pin (1)**, **washer (2)**, and **brake spring (3)** from the **adjustable nut (4)**.
- Disconnect the **adjustable nut (4)** from the **brake lever assembly (5)** and the **parking brake latch (6)**.
- Align the hole in the **brake lever (5)** with the hole in the **frame**. Hold the **brake lever (5)** in place with a 6 mm **pin or bolt (7)**.
- Pull the clutch rod forward until tight. Turn the **adjustable nut (4)** until the nut will fit through the hole in the **brake lever (5)**.
- Assemble the **adjustable nut (4)** to the **parking brake latch (6)**, **brake lever (5)** and **brake spring (3)**. Fasten with the **washer (2)** and **cotter pin (1)**.
- Remove the 6 mm **pin or bolt (7)**.
- If the belt still slips after the clutch has been adjusted, then the motion drive belt is worn or damaged and must be replaced. See "How To Replace The Motion Drive Belt".

How To Check And Adjust The Drive Brake (Figure 24)

Completely push the clutch/brake pedal forward. Set the parking brake. Move the shift lever to the neutral (N) position. Push the unit. If the rear wheels rotate, adjust or replace the brake pads. Adjust the **drive brake (1)** as follows.

1. The location of the **drive brake (1)** is on the right side of the **gearbox (3)**.
2. Make sure the parking brake is set and the shift lever is in neutral (N). Turn the **hex nut (2)** in a clockwise direction until the rear wheels do not turn when the unit is pushed forward.
3. Release the parking brake and push the unit. If the unit does not roll, turn the **hex nut (2)** in a counter-clockwise direction until the unit rolls.
4. Set the parking brake. Push the unit. If the rear wheels do not turn, the **drive brake (1)** is correctly adjusted. Release the parking brake.

WARNING: If you cannot correctly adjust the drive brake, replace the brake pads. Correct replacement parts and assistance are available from an authorized service centre.

How To Remove The Battery (Figure 4)

To charge or clean the **battery (1)**, remove the **battery (1)** from the unit as follows.

WARNING: To prevent sparks, disconnect the black battery cable (8) from the negative (-) terminal before you disconnect the red cable (5).

WARNING: The battery contains sulphuric acid which is harmful to the skin, eyes and clothing. If the acid gets on the body or clothing, wash with water.

1. Disconnect the **black cable (8)** from the negative (-) terminal.
2. Disconnect the **red cable (5)** from the **positive (+) terminal (4)**.
3. Lift the **battery tray (3)** and the **battery (1)** out of the unit.

How To Charge The Battery (Figure 4)

WARNING: When you charge the battery, do not smoke. Keep the battery away from any sparks. The fumes from the battery acid can cause an explosion.

1. Before you charge the **battery (1)**, remove the **battery (1)**.
2. To charge the **battery (1)**, use a 12 volt battery charger. Charge at a rate of 6 amperes for 1 hour.
3. Install the **battery (1)**.

WARNING: To prevent sparks, fasten the red cable to the positive (+) terminal before you connect the black cable.

4. Fasten the **red cable (5)** to the **positive (+) terminal (4)** with the fasteners as shown.
5. Fasten the **black cable (8)** to the negative (-) terminal with the fasteners as shown.

F-040730L

How To Level The Mower Housing (Figure 25 and Figure 26)

If the mower housing is level, the blade will cut easier and the lawn will look better.

WARNING: Before you make an inspection, adjustment, or repair to the unit, disconnect the wire to the spark plug. Remove the spark plug wire to prevent the engine from starting by accident

1. Make sure the unit is on a hard flat surface.
2. Check the air pressure in the tyres. If the air pressure is incorrect, the mower housing will not cut level. Make sure the tyres are inflated to: Front Tyres 0,97 BAR (14 PSI), Rear Tyres 0,69 BAR (10 PSI).
3. (Figure 25) Move the **lift lever (1)** to the **lowest position (2)**.

WARNING: The lift lever (3) is spring loaded. Make sure the lift lever (1) is locked in the lowest position (2).

4. (Figure 26) Loosen the left and right **adjuster knobs (1)**. Push down on each side of the mower housing. Make sure both sides of the mower housing are setting on a flat surface. Also, make sure the **lift links (2)** are loose and can easily move up or down.
5. Push down on the **adjuster knobs (1)** and the **lift links (2)**. Tighten the left and right **adjuster knobs (1)**. Make sure the **adjuster knobs (1)** are tight. If necessary, use a wrench to tighten the **adjuster knobs (1)**.
6. (Figure 25) Raise the **lift lever (1)**.
7. Mow for a short distance. If the height of cut is not level, repeat the above steps.

Where To Lubricate (Figure 27)



Models with grease fittings:
Lubricate with grease gun.
Apply grease with a brush to the areas shown.
Lubricate the areas shown with engine oil.

NOTE: Apply grease to the steering gear assembly.

CAUTION: If the unit is operated in dry areas that have sand, use a dry graphite spray to lubricate the unit.

Check The Tyres

Check the air pressure in the tyres. Tyres with too much air pressure will cause the unit to ride rough. Also, the wrong air pressure will keep the mower housing from cutting level. The correct air pressure is: Front Tyres 0,97 BAR (14 PSI), Rear Tyres 0,69 BAR (10 PSI).

How To Replace The Motion Drive Belt

1. Remove the mower housing. See the instructions on "How To Remove The Mower Housing".
2. Completely push the pedal forward and engage the parking brake.
3. (Figure 28) Remove the **idler pulley (1)**.

4. (Figure 29) To access the **belt guides (1)**, remove the battery and battery tray. See "How To Remove The Battery".
5. Loosen the **belt guides (1)** at the **drive pulley (2)**.
6. (Figure 28) Remove the **motion drive belt (3)** from the **drive pulley (4)**.
7. (Figure 30) Remove the **adjuster nut (2)** from the **shifter bracket (3)**. Pull the motion drive belt over the **shifter bracket (3)**.
8. (Figure 31) To remove the **motion drive belt (1)** from the **stack pulley (2)**, pull the front end of the belt under the **stack pulley (2)** and then back between the stack pulley and the **steering plate (3)**.
9. (Figure 32) Remove the **access panel (1)**.
10. Remove the two **screws (4)** that attach the **steering shaft assembly (2)**. Raise the steering wheel and **steering shaft assembly (2)**. Pull the **motion drive belt (3)** under the **steering shaft assembly (2)**.
11. Remove the motion drive belt. A correct replacement part or assistance is available from an Authorized Service Centre in your area.
12. To install the motion drive belt, reverse the above steps.
13. (Figure 33) Check the routing of the **motion drive belt (1)**. Make sure the motion drive belt is installed correctly on the **idler pulley (2)**. Make sure the **steering shaft assembly (3)** is inside the **motion drive belt (1)**.

How To Replace The Mower Drive Belt (Figure 22)

1. Remove the mower housing. See the instructions on "How To Remove The Mower Housing".
2. Pull the **belt retainer (1)** away from the **idler pulley (2)** and remove the **mower drive belt (3)**.
3. Pull the **belt guide (4)** and the **brake assembly (7)** away from the **mandrel pulley (5)** and remove the **mower drive belt (3)**. A correct replacement part or assistance is available from an Authorized Service Centre in your area.
4. To install the mower drive belt, reverse the above steps.
5. Before you mow, check the blade rotation control. See the instructions on "How To Adjust The Blade Rotation Control".

How To Remove The Mower Housing (Figure 34)

1. Move the **blade rotation control (1)** to the **DISENGAGE** position.
2. Move the **lift lever (2)** to the lowest position.

WARNING: The lift lever (2) is spring loaded. Make sure the lift lever (2) is locked in the lowest position.

3. Remove the hair pins and the washers from the **adjuster arms (3)**. See illustrations "C" and "D".
4. Remove the hair pins and washers from the **suspension links (4)**. See illustrations "A" and "B".
5. Disconnect the **extension spring (5)** from the **blade control rod (6)**. See illustration "E".

6. Disconnect the **front hanger (9)** from the axle support. See illustration "F".
7. Remove the **mower drive belt (7)** from the **stack pulley (8)**. See illustration "G".
8. (**Figure 16**) Disconnect the **rubber strap (1)** from the **connector tube (3)**. Slide the **connector tube (3)** off the **extension tube (8)**.
9. Pull the mower housing away from the right side of the unit.
10. To install the mower housing, reverse the above steps.

How To Replace The Fuse

If the fuse is blown, the engine will not start. Remove the fuse and replace with a 15 amp. automotive fuse.

Storage (over 30 days)

At the end of each year, prepare the unit for

storage as follows.

1. Drain the fuel from the carburettor and the fuel tank. Change the engine oil. See the engine manufacturer's instructions.
2. Clean the unit.
3. Charge the battery. See "How To Charge The Battery".

How To Order Replacement Parts

The replacement parts are shown either on the back pages of this Instruction Book or in a separate Parts List Book.

Use only manufacturer's authorized or approved replacement parts. The letter placed on the end of the part number denotes the type of finish for the part, C for chrome, Z for zinc, a PA for purchased assembly. It is important that you include this when ordering a part. Do not use attachments or accessories not specifically

recommended for this unit. In order to obtain proper replacement parts you must supply the model number of your mower (see nameplate).

Replacement parts are available from your local **Hayter** authorised dealer.

If you are unable to obtain parts or service in the manner outlined above, then contact:

**HAYTER LIMITED, Service Department,
Spellbrook, Bishop's Stortford,
Hertfordshire. CM23 4BU.**

UK ONLY: Details of your local **Hayter** authorised dealer are contained in Yellow Pages or contact: Freephone 0800 616298.

When ordering the following information is required:

- (1) The Model Number
- (2) Serial Number
- (3) Part Number
- (4) Quantity

TROUBLE SHOOTING CHART

PROBLEM: The engine will not start.

1. Follow the steps, "How To Start The Engine" in this book.
2. Electric-Start Models: Clean the battery terminals. Tighten the cables.
3. Check for a loose wire. Tighten the limit switches. (See the wiring diagram.)
4. Drain the fuel tank. Clean the fuel line. Replace the fuel filter.
5. Remove the spark plug(s). Move the throttle to the SLOW position. Turn the ignition key to the ON position. Try to start the engine several times. Install the spark plug.
6. Replace the spark plug.
7. Adjust the carburettor.

PROBLEM: The engine will not turn over.

1. Follow the steps, "How To Start The Engine" in this book.
2. Electric-Start Models: Charge the battery.
3. Replace the fuse.
4. Check the wiring harness for damage or a loose connection. Repair the damaged wire.
5. Electric-Start Models: replace the solenoid. Recoil-Start Models: replace the module.

PROBLEM: The engine is difficult to start.

1. Adjust the carburettor.
2. Replace the spark plug.
3. Replace the fuel filter.

PROBLEM: The engine does not run smooth or has a loss of power.

1. Check the oil.
2. Clean the air filter.
3. Clean the air screen.
4. Replace the spark plug.
5. The engine is working too hard. Use a lower gear.
6. Adjust the carburettor.
7. Replace the fuel filter.

PROBLEM: The engine does not run smooth at fast speed.

1. Replace the spark plug.
2. Adjust the throttle control.

3. Clean the air filter.
4. Replace the fuel filter.

PROBLEM: The engine stops when the blades are engaged.

1. Check the wiring harness for damage or a loose connection. Repair the damaged wire.
2. Grass bag must be installed (applies only to model with rear discharge grass bag).

PROBLEM: On slopes, the engine stops.

1. Mow up and down slopes. Never mow across a slope.

PROBLEM: The engine will not idle.

1. Replace the spark plug.
2. Clean the air filter.
3. Adjust the carburettor.
4. Adjust the throttle control.
5. Drain the fuel tank. Clean the fuel line. Replace the fuel filter.

PROBLEM: A hot engine causes a decrease in power.

1. Clean the air screen.
2. Check the oil.
3. Adjust the carburettor.
4. Replace the fuel filter.

PROBLEM: Excessive vibration.

1. Replace the blade.
2. Check for loose engine bolts.
3. Decrease the air pressure in the tyres.
4. Adjust the carburettor.
5. Check for a damaged belt or damaged pulley. Replace the damaged parts.

PROBLEM: The grass does not discharge correctly.

1. Stop the engine. Clean the mower housing.
2. Raise the height of cut.
3. Replace or sharpen the blade(s).
4. Move the shift lever to a slower speed.
5. Move the throttle control to the FAST position.
6. Replace the spring for the blade idler.

7. Clean the extension tube and the connector tube (applies only to model with rear discharge grass bag).

PROBLEM: The mower housing does not cut level.

1. Check the air pressure in the tyres.
2. Adjust the level of the mower housing.
3. Check the front axle. If the front axle does not freely pivot, loosen the axle bolt(s).

PROBLEM: The mower blades will not rotate.

1. Check the mower drive belt. Make sure the belt is installed correctly.
2. Replace the mower drive belt.

PROBLEM: The unit will not move when the clutch is engaged.

1. Check the motion drive belt. Make sure the belt is installed correctly.
2. Adjust the clutch.
3. Replace the motion drive belt.

PROBLEM: The unit moves slower or stops when the clutch is engaged.

1. Adjust the clutch.
2. Replace the motion drive belt.

PROBLEM: When the clutch/brake pedal is released, belt noise can be heard.

1. Temporary belt noise does not change the operation of the unit. If belt noise is continuous, check the routing of the belt. Make sure the belt is inside all belt guides.
2. If the noise is continuous, adjust the clutch.

PROBLEM: The rear wheels spin over uneven terrain.

1. Check the front axle. If the front axle does not freely pivot, loosen the axle bolt(s).

PROBLEM: The transaxle is difficult to shift between gears with the engine running and the clutch depressed.

1. Check the clutch adjustment to make sure the belt stops when the clutch pedal is depressed with the transaxle in (N) neutral.
2. Check the belt guides around the transaxle drive pulley. Make sure the belt guides do not touch the pulley.

CODE131B

REPAIR PARTS CHASSIS & HOOD

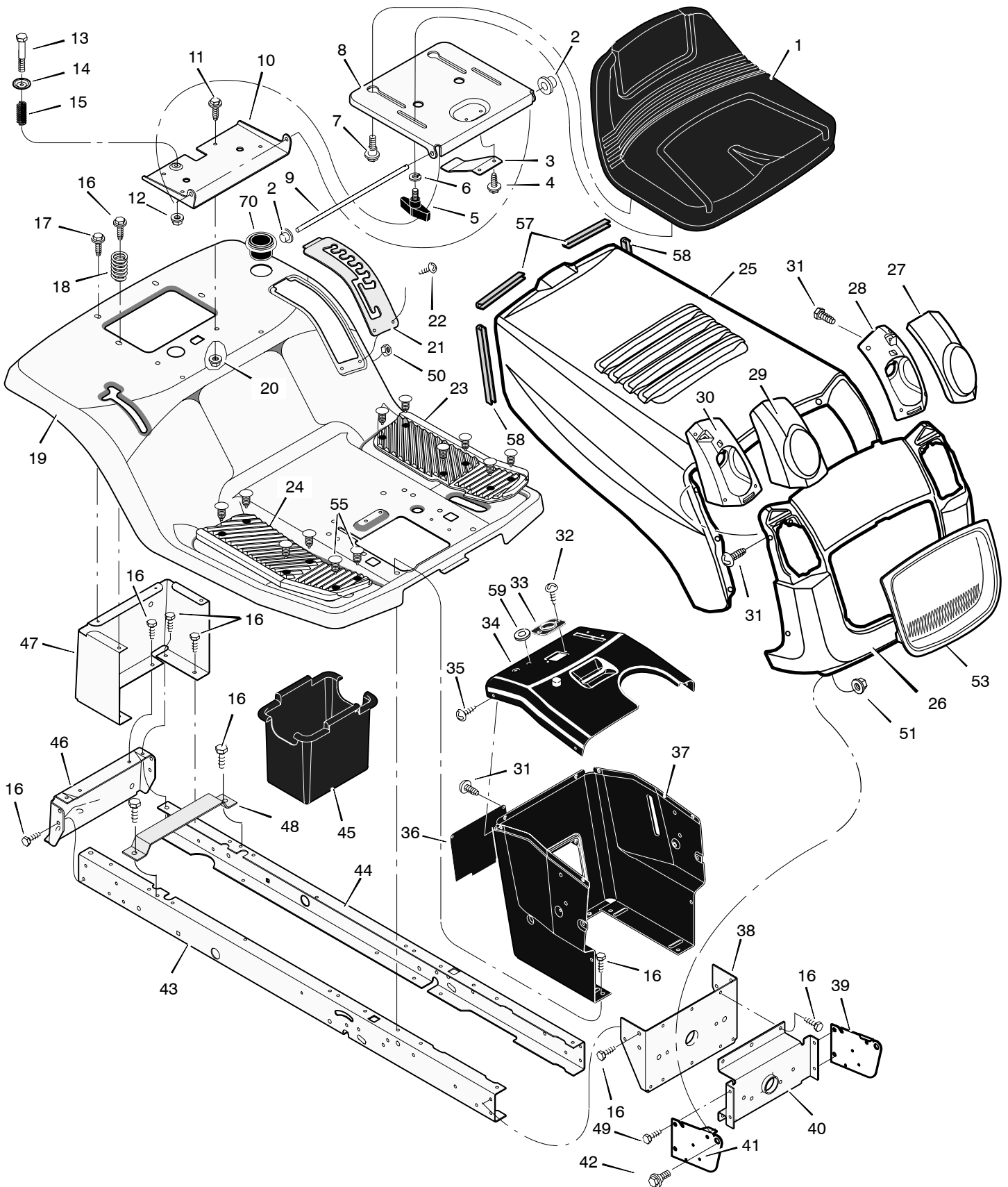

CODE131B

REPAIR PARTS CHASSIS & HOOD

Key No.	Part No.	Description	Key No.	Part No.	Description
1	MU1001028	Seat	31	MU26x270	Screw
2	MU028x23	Cap, Push On	32	MU26x238	Screw
3	MU094057	Spring	33	MU1001491	Bearing, Steering
4	MU26x229	Screw	34	MU1001584E701	Dash
5	MU1001054	Bolt, Wing	35	MU26x201	Screw
6	MU017x47	Washer	36	MU093007E701	Panel, Access
7	MU009x56	Bolt, Shoulder	37	MU095318E701	Support, Dash
8	MU094154E701	Support, Seat	38	MU1001270E701	Bracket, Rear Hanger
9	MU094156 Z	Rod, Pivot	39	MU094085E701	Support, Left Grille
10	MU1001648E701	Bracket, Pivot	40	MU094007E701	Axle, Hanger
11	MU001x45	Bolt	41	MU094084E701	Support, Right Grille
12	MU015x89	Nut	42	MU009x58	Bolt, Shoulder
13	MU009x55	Bolt, Shoulder	43	MU1001928E701	Frame, Right
14	MU094155 Z	Washer	44	MU1001927E701	Frame, Left
15	MU164x31	Spring	45	MU690424	Container, Battery
16	MU26x249	Screw	46	MU1001002E701	Plate, Hitch
17	MU26x263	Screw	47	MU690434E701	Panel, Rear
18	MU164x30	Spring	48	MU690482E701	Support, Battery
19	MU1001558E549	Deck, Seat	49	MU26x277	Screw
20	MU15x123	Nut	50	MU015x81	Nut
21	MU094151E701	Plate, Index	51	MU15x124	Nut
22	MU009x49	Screw	53	MU1001540	Insert, Grille
23	MU1001582	Mat, Left	55	MU0193x1	Fastener, Panel
24	MU1001578	Mat, Right	57	MU1001652	Trim, Hood (3.75")
25	MU1001538E549	Hood	58	MU1001653	Trim, Hood (6.5")
26	MU1001531E549	Grille	59	MU1001755	Grommet, Parking Brake
27	MU1001546	Lens, Left	70	MU1001542	Holder, Cup
28	MU1001544	Housing, Left Headlamp	—	MU1001865	Bag, Parts
29	MU1001545	Lens, Right	—	MUF-040730L	Instruction Book & Parts List
30	MU1001543	Housing, Right Headlamp			

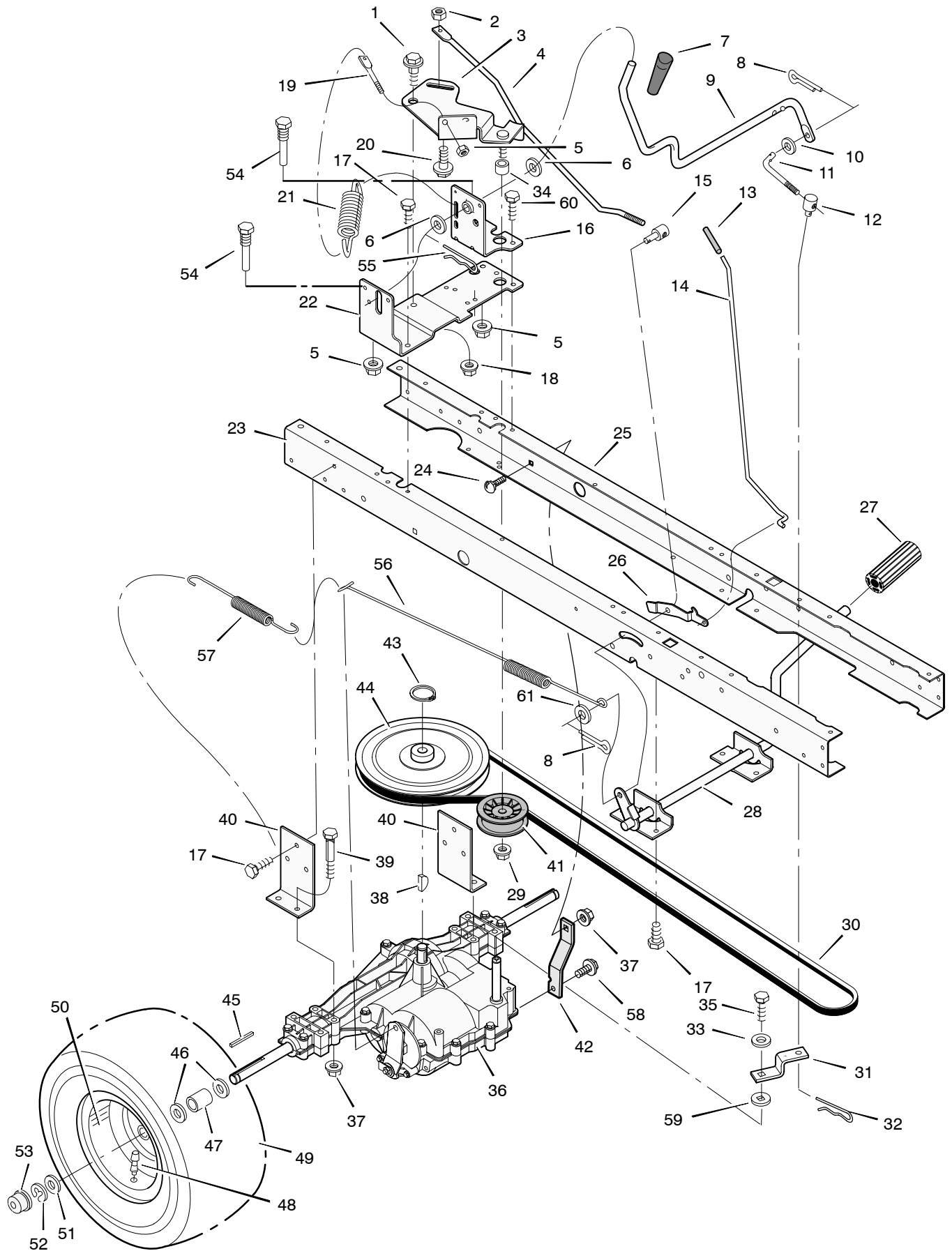

CODE131B

REPAIR PARTS MOTION DRIVE

Key No.	Part No.	Description	Key No.	Part No.	Description
1	MU009x39	Bolt, Shoulder	32	MU0031x6	Pin, Hair
2	MU015x89	Nut, Hex	33	MU017x38	Washer
3	MU690173 Z	Arm, Idler	34	MU690369	Spacer
4	MU094041 Z	Rod, Clutch	35	MU06x105	Bolt
5	MU015x79	Nut	36	— ** —	Transaxle, Peerless
6	MU17x102	Washer	37	MU015x88	Nut
7	MU092697	Grip	38	MU020697	Key, Woodruff
8	MU030x20	Pin, Cotter	39	MU01x155	Bolt
9	MU094043 Z	Lever, Shift	40	MU094008E701	Bracket, Transaxle
10	MU017x47 Z	Washer	41	MU690409	Pulley
11	MU094044 Z	Link, Shift	42	MU094433E701	Bracket, Transaxle Support
12	MU021920 Z	Nut, Adjuster	43	MU0011x7	Ring, Snap
13	MU091079	Grip	44	MU095094	Pulley, Drive
14	MU1001245 Z	Rod, Parking Brake	45	MU021553	Key, Square
15	MU094815 Z	Nut, Adjuster	46	MU17x160	Washer
16	MU1001303 Z	Bracket, Shift Pivot	47	MU690554 Z	Spacer, Transaxle
17	MU26x249	Screw	48	MU024373	Stem, Valve
18	MU015x84	Nut	49		Tire *
19	MU094042 Z	Mount, Stud Spring	—	MU407049	Tube
20	MU009x54	Bolt, Shoulder	50	MU690376–601	Wheel & Tire Assembly
21	MU165x116	Spring, Extension	51	MU17x195	Washer
22	MU1001302E701	Bracket, Right Shifter	52	MU0011x3	E–Ring
23	MU1001928E701	Frame, Right	53	MU094618	Hub Cap
24	MU002x53	Bolt, Carriage	54	MU093349	Guide, Belt
25	MU1001927E701	Frame, Left	55	MU0031x4	Pin, Hair
26	MU094045 Z	Latch, Parking Brake	56	MU165x141	Spring, Extension
27	MU021544	Pedal	57	MU165x92	Spring, Extension
28	MU94038E700	Lever, Brake/Clutch	58	MU26x216	Screw
29	MU015x98	Nut	59	MU17x148	Washer
30	MU037x87	Belt, Motion Drive	60	MU26x267	Screw
31	MU094031 Z	Yoke, Shift	61	MU17x169	Washer

* When you order a tire, make sure to give the brand name of the tire so that the tread pattern on the tire will match.

** For information on Replacement Parts for this transaxle contact the manufacturer.

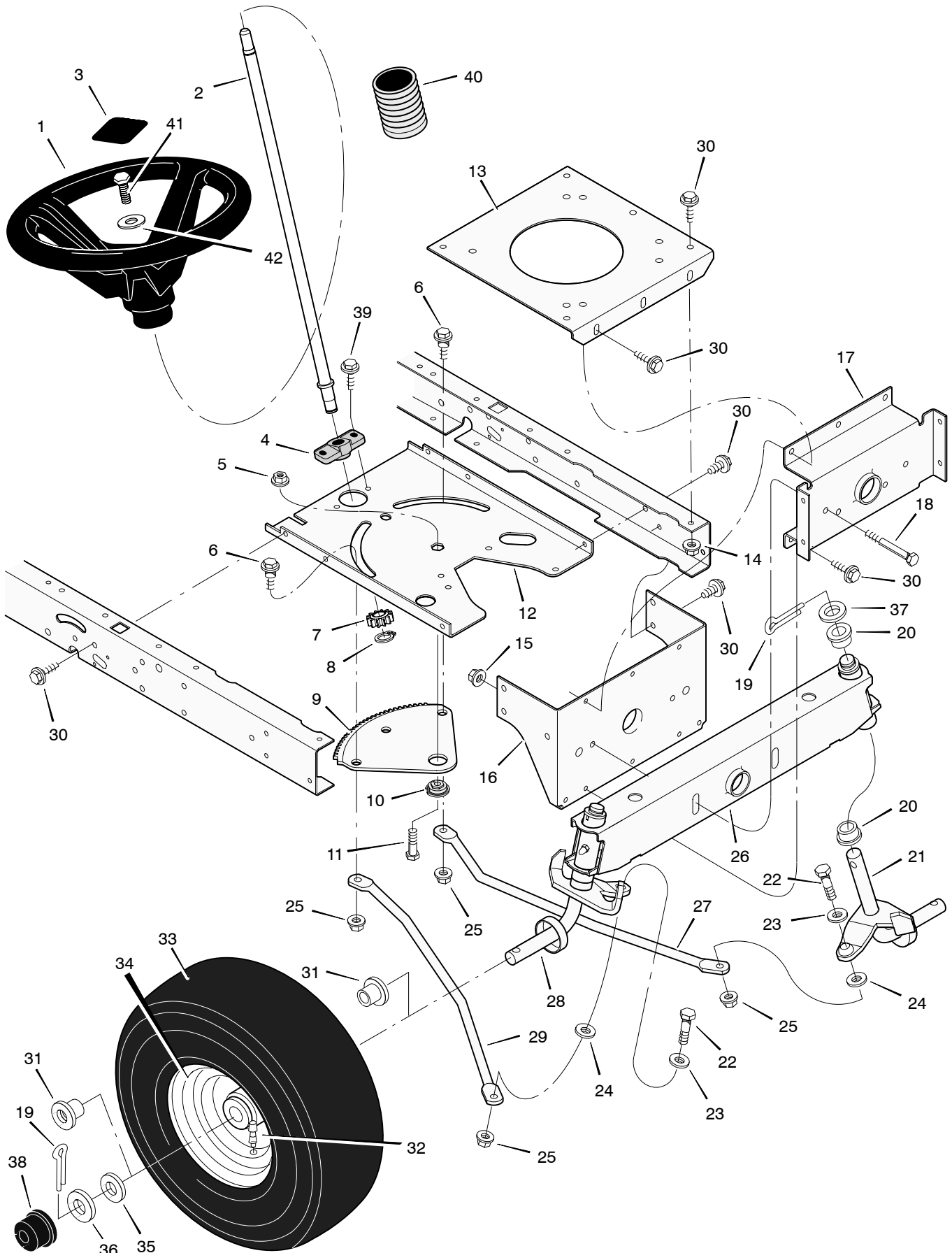

CODE131B

REPAIR PARTS STEERING

Key No.	Part No.	Description	Key No.	Part No.	Description
1	MU095185	Wheel, Steering	23	MU17x104	Washer
2	MU690625	Post, Steering	24	MU017x53 Z	Washer
3	MU711326	Insert, Steering Wheel	25	MU015x84	Nut, Flange
4	MU094124	Bearing, Lower	26	MU690210E701	Axle Assembly
5	MU15x111	Nut, Flange	27	MU095329E701	Drag Link, Left
6	MU009x57	Bolt, Shoulder	28	MU1001298E701	Spindle Assembly, Right
7	MU690183	Gear, Pinion	29	MU095328E701	Drag Link, Right
8	MU011x25	Ring, Snap	30	MU26x249	Screw
9	MU094121	Gear, Sector	31	MU091334	Bearing, Wheel
10	MU094123	Bearing	32	MU024373	Stem, Valve
11	MU001x84	Bolt	33		Tire *
12	MU1001121E701	Plate, Steering	—	MU407046	Tube
13	MU094006E701	Plate, Engine	34	MU690377-601	Wheel and Tire Assembly
14	MU015x88	Nut, Flange	35	MU17x195	Washer
15	MU15x118	Nut, Flange	36	MU17x192	Washer
16	MU1001270E701	Bracket, Hanger	37	MU017x83	Washer
17	MU094007E701	Axle, Hanger	38	MU094618	Hub Cap
18	MU01x146	Bolt	39	MU26x267	Screw
19	MU030x49	Pin, Cotter	40	MU092059	Bellows
20	MU690150	Bearing	41	MU0025x3	Bolt
21	MU1001299E701	Spindle Assembly, Left	42	MU17x146	Washer
22	MU01x111	Bolt			

* When you order a tire, make sure to give the brand name of the tire so that the tread pattern on the tire will match.

CODE131B

REPAIR PARTS MOWER HOUSING SUSPENSION

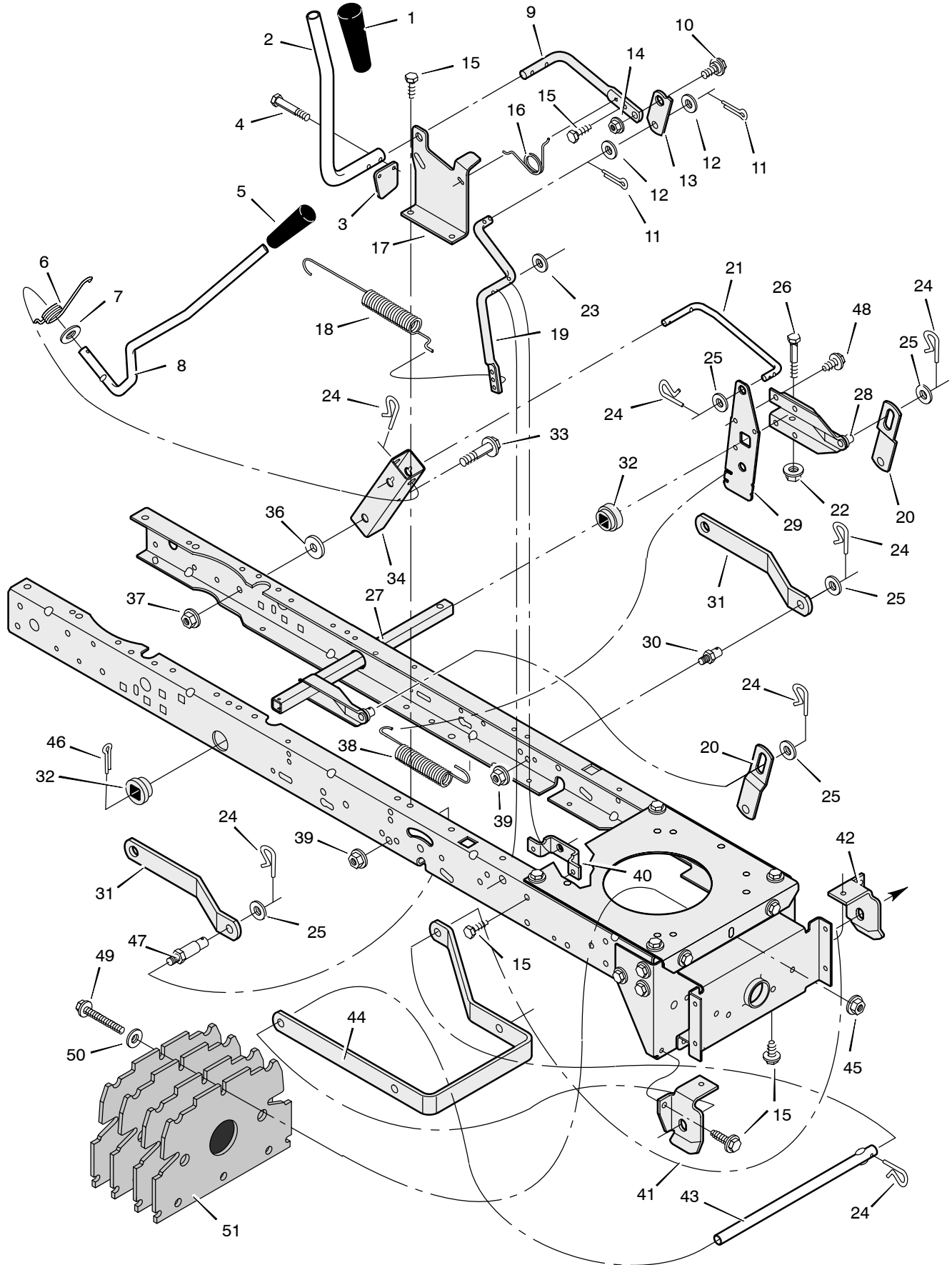

CODE131B

REPAIR PARTS MOWER HOUSING SUSPENSION

Key No.	Part No.	Description	Key No.	Part No.	Description
1	MU092698	Grip	26	MU001x74	Bolt, Hex
2	MU094157 Z	Handle, PTO	27	MU690386E700	Arm Assembly, Right Lift
3	MU094022 Z	Pad, Switch	28	MU094180E700	Arm, Right Lift
4	MU0025x3	Bolt	29	MU094030E700	Plate, Lift Arm
5	MU092697	Grip	30	MU094067	Pin
6	MU166x40	Spring	31	MU094055E701	Bracket, Rear Suspension
7	MU17x103	Washer	32	MU094065	Bushing, Lift Tube
8	MU690533	Handle, Lift	33	MU009x53	Bolt, Shoulder
9	MU094017 Z	Lever, PTO	34	MU094015E700	Bracket, Pivot
10	MU009x39	Bolt, Shoulder	36	MU17x191	Washer
11	MU030x20	Pin, Cotter	37	MU015x84	Nut, Flange
12	MU017x57	Washer	38	MU165x117	Spring
13	MU094004 Z	Link, PTO	39	MU015x68	Nut, Flange
14	MU015x84	Nut, Flange	40	MU094005E700	Bracket, PTO
15	MU26x249	Screw	41	MU094026E700	Hanger, Right Deck
16	MU166x39	Spring	42	MU094027E700	Hanger, Left Deck
17	MU094018E701	Bracket, PTO	43	MU094158 Z	Rod, Hanger
18	MU165x116	Spring	44	MU690381E700	Hanger, Front
19	MU690394E701	Crank, PTO	45	MU015x89	Nut, Flange
20	MU094053E701	Link, Lift	46	MU030x49	Pin, Cotter
21	MU094028 Z	Link, Lift Handle	47	MU690382	Pin, Threaded Shoulder
22	MU15x118	Nut, Flange	48	MU26x49	Screw
23	MU17x57	Washer	49	MU01x106	Bolt, Hex
24	MU0031x4	Pin, Hair	50	MU017x38	Washer
25	MU017x91	Washer	51	MU690370E701	Plate, Weight (4 Required)

CODE131B

REPAIR PARTS MOWER HOUSING

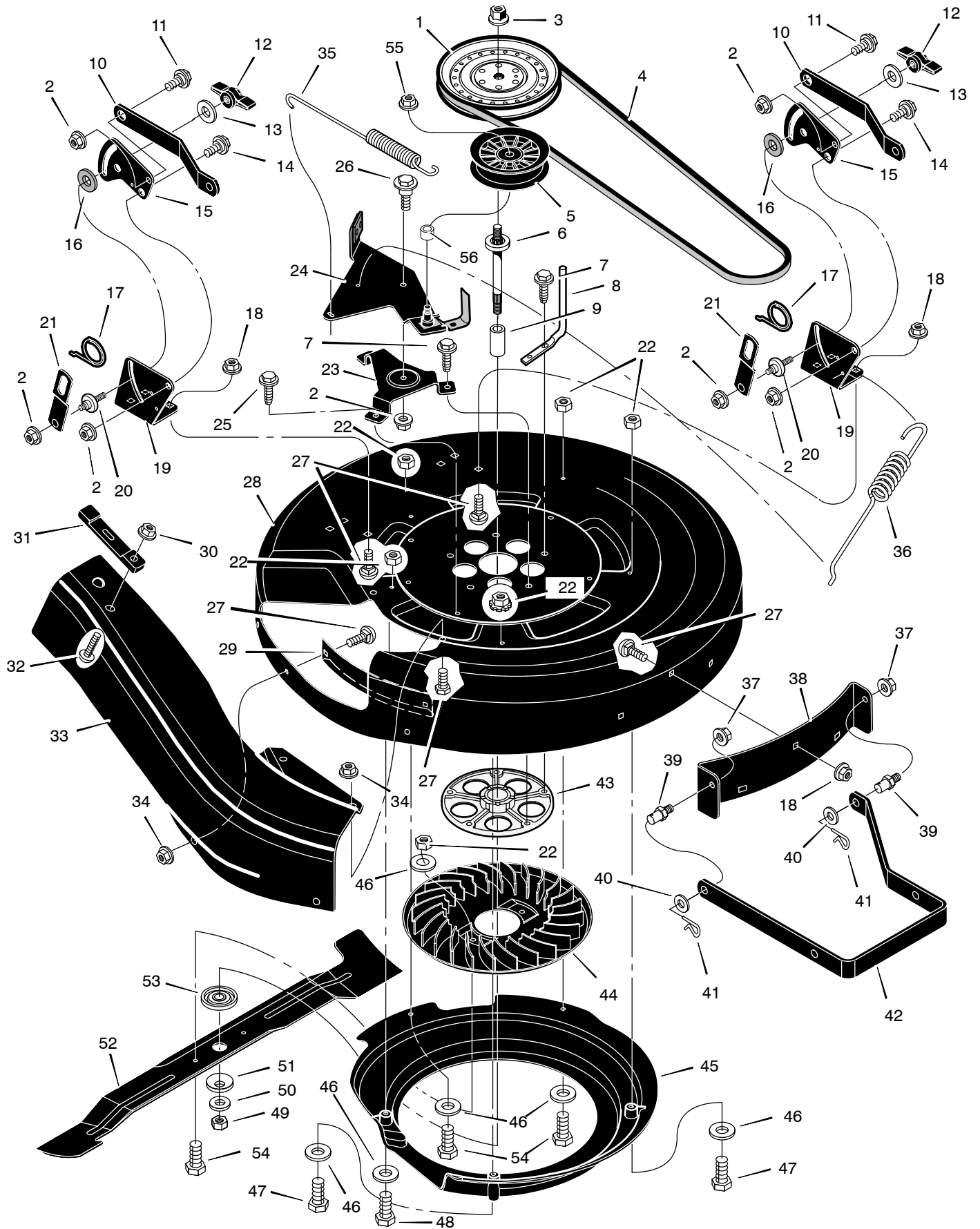

CODE131B

REPAIR PARTS MOWER HOUSING

Key No.	Part No.	Description	Key No.	Part No.	Description
1	MU690432	Pulley	30	MU015x89	Nut, Flange
2	MU015x84	Nut, Flange	31	MU054695	Strap, Rubber
3	MU15x140	Nut	32	MU01x139	Screw
4	MU037x74	Belt, Blade	33	MU690367	Chute
5	MU690387	Pulley, Idler	34	MU015x79	Nut
6	MU094129	Mandrel	35	MU165x118	Spring, PTO
7	MU0025x7	Screw	36	MU165x140	Spring, Extension
8	MU092424	Guide, Belt	37	MU015x84	Nut, Flange
9	MU094130	Spacer	38	MU690380E700	Bracket, Front Deck
10	MU094055E701	Bracket, Rear Suspension	39	MU094067	Pin, Threaded Shoulder
11	MU009x52	Bolt, Shoulder	40	MU017x91	Washer
12	MU094068	Knob	41	MU0031x4	Pin, Hair
13	MU017x45	Washer	42	MU690381E700	Hanger, Front
14	MU009x51	Bolt, Shoulder	43	MU1401275	Housing, Jackshaft
15	MU690379E700	Plate, Suspension	44	MU690359	Fan, Assist
16	MU094137	Pad, Friction	45	MU1001237E701	Housing, Fan
17	MU166x43	Spring	46	MU017x37	Washer
18	MU015x79	Nut, Flange	47	MU001x71	Bolt
19	MU690378E700	Bracket, Rear Deck	48	MU001x106	Bolt
20	MU095194	Pin, Hanger	49	MU15x100	Nut
21	MU094053	Link, Lift	50	MU17x165	Washer
22	MU15x116	Nut	51	MU17x166	Washer, Belleville
23	MU690427E700	Bracket, Idler Arm	52	MU690398E701	Blade
24	MU690647	Assembly, Idler Arm & Pad	53	MU092466	Adapter, Blade
25	MU26x249	Screw	54	MU01x121	Bolt
26	MU009x39	Bolt, Shoulder	55	MU015x98	Nut, Flange
27	MU002x64	Bolt, Carriage	56	MU690369	Spacer
28	MU690530E700	Housing, Blade	1-56	MU776110	Blade Housing, Complete
29	MU690399E700	Baffle			

CODE131B

REPAIR PARTS ENGINE MOUNT

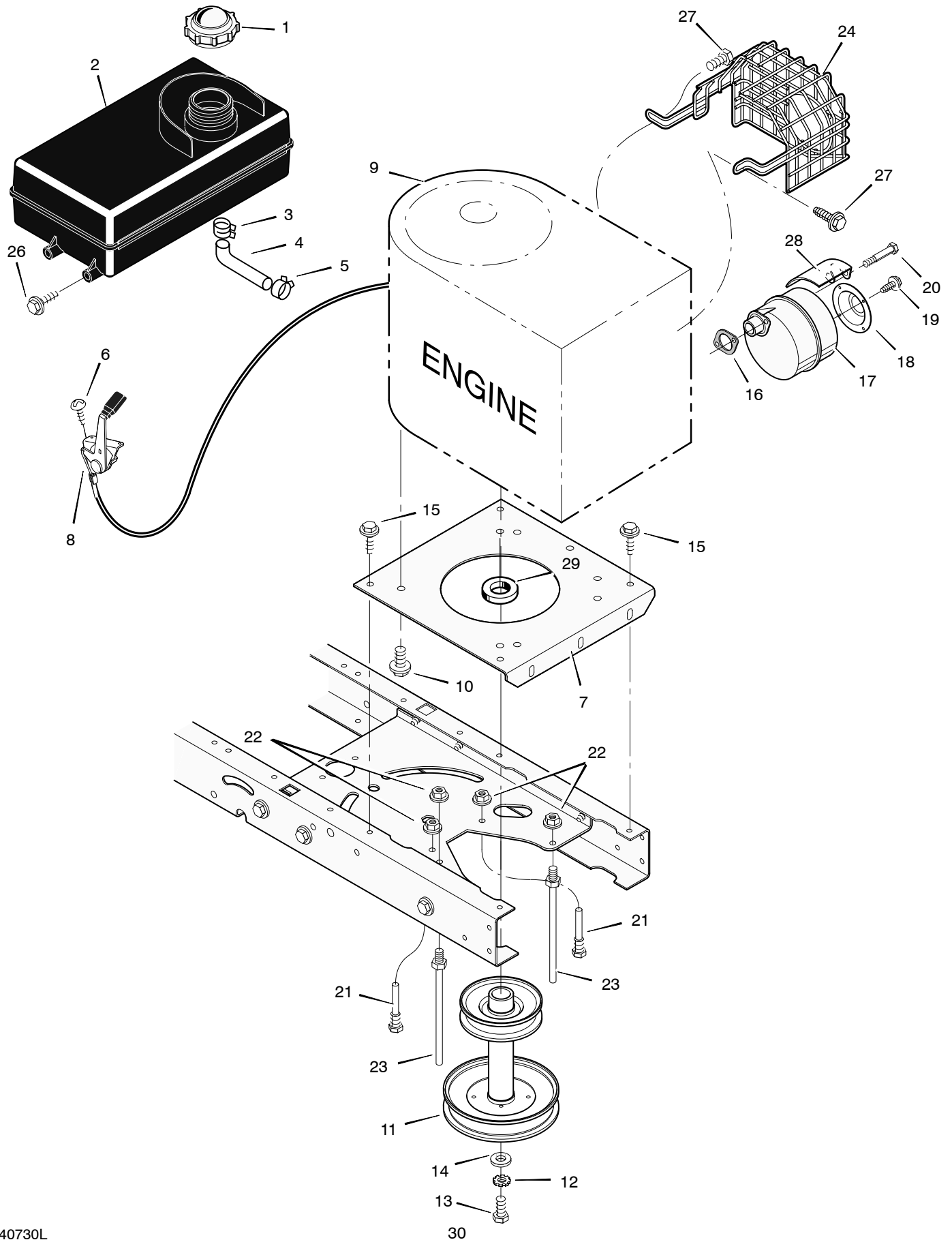

Key No.	Part No.	Description
1	MU092317	Fuel Cap (Incl'd w/Key 2)
2	MU690280	Fuel Tank
3	MU095197	Hose Clamp (Incl'd w/Key 2)
4	MU7601033	Fuel Line (Incl'd w/Key 2) (Must cut to Length)
5	MU095197	Hose Clamp
6	MU26x201	Screw
7	MU094006E701	Plate, Engine
8	MU092371	Throttle Control
9	— * —	Engine, Briggs & Stratton
10	MU0025x7	Bolt, Engine Mount
11	MU690439 Z	Stack Pulley Assembly
12	MU019x35	Lockwasher
13	MU01x140	Bolt, Hex
14	MU17x170	Washer
15	MU26x249	Screw
16	MU091309	Gasket
17	MU091271	Muffler
18	MU1001350	Deflector, Muffler
19	MU26x208	Screw
20	MU01x134	Bolt, Hex
21	MU093349	Guide, Belt
22	MU015x79	Nut, Flange
23	MU094066	Guide, Belt
24	MU10015950 Z	Shield, Heat
26	MU26x253	Screw
27	MU26x263	Screw
28	MU091277	Shield, Heat
29	MU093077	Spacer, Engine

* For information on Replacement Parts for this engine contact the manufacturer.

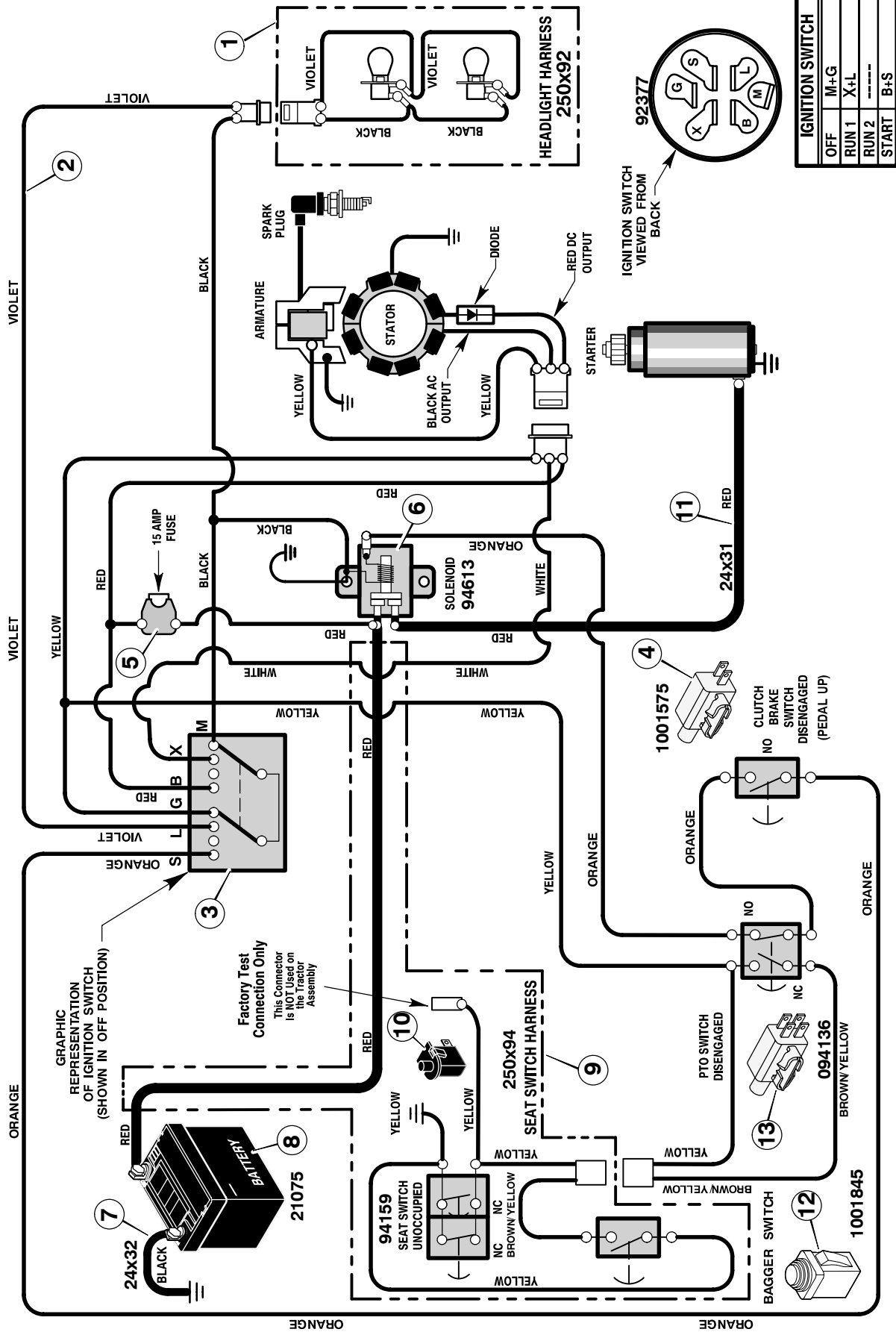

MAIN HARNESS: 250X126
REAR HARNESS: 250X130
LIGHT HARNESS: 250X92

Key No.	Part No.	Description
1	MU250x92	Harness, Light Wire
	MU1001716	Socket, Light
	MU090084	Bulb, Light
2	MU250x126	Harness, Chassis Wire
3	MU092377	Switch, Ignition
	MU020729	Key, Ignition
	MU091489	Nut, Hex
	MU091488	Cap, Ignition
4	MU1001575	Switch, Limit
5	MU302031	Fuse
	MU407078	Holder, Fuse
6	MU094613	Solenoid
	MU26x229	Screw, Mounting
	MU15x116	Locknut
7	MU024x32	Cable, Battery Ground
	MU26x229	Screw, Ground Cable
8	MU021075	Battery
	MU002x82	Bolt, Carriage
	MU014x79	Wingnut
	MU690604	Boot, Battery –Positive
9	MU250x130	Harness, Seat Switch Wire
10	MU094159	Switch, Seat Sensor
11	MU024x31	Cable
12	MU1001845	Switch, Bag Sensor
13	MU094136	Switch, Limit

CODE131B

REPAIR PARTS GRASS BAGGER

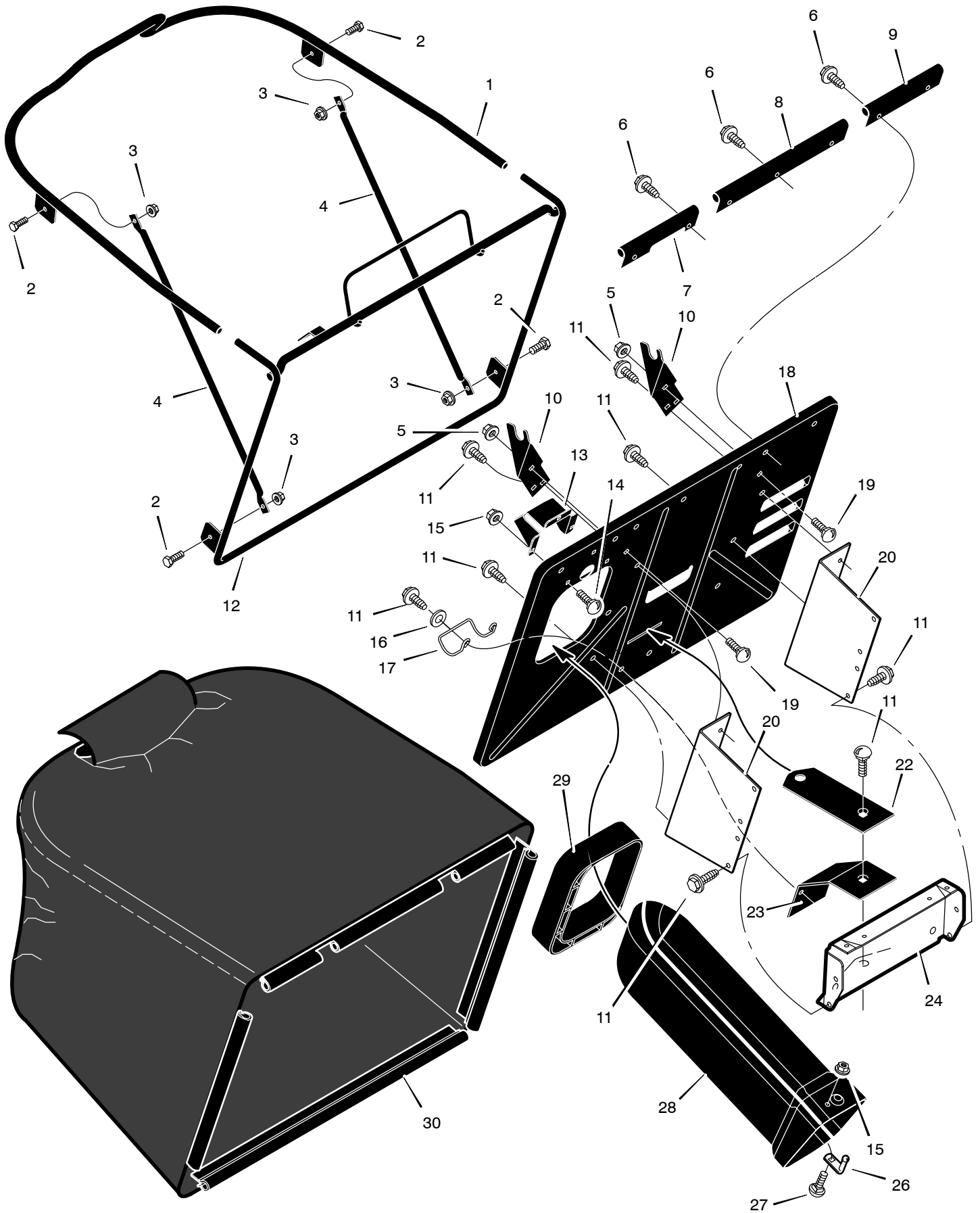

CODE131B

REPAIR PARTS GRASS BAGGER

Key No.	Part No.	Description	Key No.	Part No.	Description
1	MU690404	Tube, Top	15	MU015x89	Nut, Flange
2	MU01x121	Bolt	16	MU17x185	Washer
3	MU15x116	Nut	17	MU690402	Latch, Spring
4	MU690433	Strut, Bag	18	MU690362E701	Pan, Rear
5	MU015x79	Nut, Flange	19	MU002x53	Bolt, Carriage
6	MU0193x2	Fastener, Panel	20	MU690355E700	Bracket, Bagger Mounting
7	MU690491	Seal, Bag (Right End)	22	MU1001000E701	Plate, Hitch
8	MU690492	Seal, Bag (Center)	23	MU1001001E701	Bracket, Lower Mounting
9	MU690493	Seal, Bag (Left End)	24	MU1001002E701	Plate, Hitch
10	MU690356E700	Hinge	26	MU054563	Pin, Latch
11	MU26x249	Screw	27	MU002x39	Bolt, Carriage
12	MU690403	Assembly, Bag Frame	28	MU690368	Tube, Connecting
13	MU690400E700	Bracket, Switch	29	MU690429	Grommet, Extension Tube
14	MU002x82	Bolt, Carriage	30	MU690438	Bag, Grass

-
- (D) EG–Konformitätserklärung**
entsprechend der Richtlinie 98/37/EG
entsprechend der Richtlinie 89/336/EWG
entsprechend der Richtlinie 2000/14/EG
- (GB) EC Certificate of Conformity**
conforming to Directive 98/37/EC
conforming to Directive 89/336/EEC
conforming to Directive 2000/14/EC
- (F) Déclaration de conformité pour la CEE**
conforme à la directive 98/37/CE
conforme à la directive 89/336/CEE
conforme à la directive 2000/14/CE
- (I) Certificato di conformita' comunitario**
conforme alla Direttiva 98/37/CE
conforme alla Direttiva 89/336/CEE
conforme alla Direttiva 2000/14/CE
- (E) Declaración de Conformidad**
según la directiva 98/37/CE
según la directiva 89/336/CEE
según la directiva 2000/14/CE
- (NL) EG–Conformiteitsverklaring**
overeen komstig de Richtlijn 98/37/EG
overeen komstig de Richtlijn 89/336/EEG
overeen komstig de Richtlijn 2000/14/EG
- (P) Declaração de conformidade**
conforme com a Diretiva 98/37/CE
conforme com a Diretiva 89/336/CEE
conforme com a Diretiva 2000/14/CE
- (S) EU–konformitetsintyg**
överensstämmande med direktiv 98/37/EG
överensstämmande med direktiv 89/336/EEG
överensstämmande med direktiv 2000/14/EG
- (N) EU–konformitetserklæring**
overholder direktiv 98/37/EF
overholder direktiv 89/336/EØS
overholder direktiv 2000/14/EF
- (DK) EU–overensstemmelseserklæring**
overholder direktiv 98/37/EF
overholder direktiv 89/336/EØF
overholder direktiv 2000/14/EF
- (SF) EY: n Vaatimustenmukaisuusilmoitus**
noudattaa direktiiviä 98/37/EY
noudattaa direktiiviä 89/336/ETY
noudattaa direktiiviä 2000/14/EY

erklären in alleiniger Verantwortung, daß das Produkt
 declare in sole responsibility, that the product
 déclarons sous notre seule responsabilité que le produit
 dichiariamo sotto la nostra piena responsabilità che il prodotto
 declaramos bajo responsabilidad propia que el producto
 verklaren enig in verantwoording, dat het produkt
 declaramos com responsabilidade própria que o produto
 intyggar med ensamansvar att nedanstående produkt
 erklærer som eneansvarlig at produktet
 erklærer som eneansvarlig, at produktet
 ilmoitamme yksin vastaavamme, että tuote

312002x11A

(Fabrikat, Typ) (Make, model) (Marque, modèle) (Marca, tipo)
 (Marca, modelo) (Fabricant, type) (Marca, modelo) (Fabrikat, typ)
 (Fabrikat, type) (Mærke, type) (Merkki, malli)

auf das sich diese Erklärung bezieht, den Anforderungen der Richtlinie 98/37/EG, der Richtlinie 2000/14/EG
 (Konformitätsbewertungsverfahren gemäß Anhang VIII) und der Richtlinie 89/336/EWG und aktuellen Ergänzungen entspricht
 to which this certificate applies, conforms to the requirements of Directive 98/37/EC, Directive 2000/14/EC (conformity assessment
 procedure according to Annex VIII), and Directive 89/336/EEC and current amendments
 faisant l'objet de la déclaration est conforme aux prescriptions fondamentales stipulées dans la Directive 98/37/CE, la directive
 2000/14/CE (procédure d'évaluation de conformité selon l'annexe VIII), la directive 89/336/CEE et leurs modifications courantes
 cui la presente dichiarazione si riferisce, è conforme ai requisiti della Direttiva 98/37/CE, della Direttiva 2000/14/CE (procedura di
 valutazione della conformità secondo l'Allegato VIII), e della Direttiva 89/336/CEE e correnti emendamenti
 al cual se refiere la presente declaración corresponde a las exigencias de la directiva 98/37/CE, de la directiva 2000/14/CE (los
 procedimientos de evaluación de conformidad según el Anexo VIII) y de la directiva 89/336/CEE y enmiendas vigentes
 waarop deze verklaring betrekking heeft, overeenkomt met eisen van de richtlijn 98/37/EG, de richtlijn 2000/14/EG
 (conformiteitsbeoordelingsprocedure volgens bijlage VIII), de richtlijn 89/336/EEG en huidige wijzigingen
 ao que se refere esta declaração corresponde às exigências da Directiva 98/37/CE, Directiva 2000/14/CE (em conformidade com o
 processo de avaliação, de acordo com o Anexo VIII) e Directiva 89/336/CEE e actuais alterações
 för vilket detta intyg gäller, uppfyller kraven enligt direktiv 98/37/EG, direktiv 2000/14/EG (procedur för bedömning av överensstämmelse
 enligt tillägg VIII), 89/336/EEG samt allmänna tillägg
 som denne erklæring vedrører, oppfyller kravene i direktiv 98/37/EF, direktiv 2000/14/EF (konformitetsvurderingsprosedyre i henhold til
 annekts VIII) og direktiv 89/336/EØS og aktuelle vedlegg
 som denne erklæring vedrører, overholder kravene i direktiv 98/37/EF, direktiv 2000/14/EF (konformitetsvurderingsprocedure iflg. Annex
 VIII) og direktiv 89/336/EØF og ændringer
 johon tämä ilmoitus liittyy, vastaa direktiivin 98/37/EY, direktiivin 2000/14/EY (Liitteen VIII mukaisten yhdenmukaisuuden
 arviointitoimien), direktiivin 89/336/ETY ja nykyisten muutosten vaatimuksia

Zursachgerechten Umsetzung der EG-Richtlinien wurde(n) folgende Norm(en) und/oder technische Spezifikation(en) herangezogen:
 EN 836/A2:2001, EN 836:1997, BS EN 1033:1996 und/oder BS EN 1032:1997, EN ISO 3744:1995, ISO 11094:1991

To effect correct application of the EEC Directives, the following standards and/or technical specifications were consulted: EN
 836/A2:2001, EN 836:1997, BS EN 1033:1996 and/or BS EN 1032:1997, EN ISO 3744:1995, ISO 11094:1991

Pour mettre en pratique les Directives de la CEE, il a été tenu compte de la/des norme(s) et/ou de la/des spécification(s) technique(s)
 suivante(s): EN 836/A2:2001, EN 836:1997, BS EN 1033:1996 et/ou BS EN 1032:1997, EN ISO 3744:1995, ISO 11094:1991

Per un'opportuno riscontro della normativa CEE, è (sono) stata(e) consultata(e) la(e) seguente(i) norma(e) e/o specifica(che)
 tecnica(che): EN 836/A2:2001, EN 836:1997, BS EN 1033:1996 e/o BS EN 1032:1997, EN ISO 3744:1995, ISO 11094:1991

Con el fin de realizar de forma adecuada las exigencias en las normativas de la CEE (fué(ron) consultada(s) la(s) siguiente(s)
 normativa(s) y especificación(es) técnica(s): EN 836/A2:2001, EN 836:1997, BS EN 1033:1996 y/o BS EN 1032:1997, EN ISO
 3744:1995, ISO 11094:1991

Om de EG-richtlijnen in juiste vorm om te zetten, is/zijn van volgende norm(en) en/of technische specificatie(s) gebruik gemaakt: EN
 836/A2:2001, EN 836:1997, BS EN 1033:1996 en/of BS EN 1032:1997, EN ISO 3744:1995, ISO 11094:1991

Com o fim de realizar de forma apropriada as exigências nas normas da C.E.E. consultou-se a(s) seguinte(s) norma(s) e/ou
 especificação(ões) técnica(s): EN 836/A2:2001, EN 836:1997, BS EN 1033:1996 e/ou BS EN 1032:1997, EN ISO 3744:1995, ISO
 11094:1991

Följande norm(er) och/eller teknisk(a) specifikation(er) har legat till grund för ett fackmässigt införande av de i EU-normerna: EN
 836/A2:2001, EN 836:1997, BS EN 1033:1996 och/eller BS EN 1032:1997, EN ISO 3744:1995, ISO 11094:1991

Følgende normer og/eller tekniske spesifikasjoner er lagt til grunn for gjennomførelse av EU-retningslinjenes: EN 836/A2:2001, EN
 836:1997, BS EN 1033:1996 og/eller BS EN 1032:1997, EN ISO 3744:1995, ISO 11094:1991

Til gennemførelse af de EF-direktivet er følgende standard(er) og/eller tekniske specifikation(er) anvendt: EN 836/A2:2001, EN
 836:1997, BS EN 1033:1996 og/eller BS EN 1032:1997, EN ISO 3744:1995, ISO 11094:1991

ETY-direktiivin oikean soveltamisen varmistamiseksi on käytetty seuraavia standardeja ja/tai teknisiä erittelyjä: EN 836/A2:2001, EN
 836:1997, BS EN 1033:1996 ja/tai BS EN 1032:1997, EN ISO 3744:1995, ISO 11094:1991

Bauart	RASENTRAKTOR
Category	LAWNMOWER
Categorie	TONDEUSE A GAZON
Categoria	TORSAERBA
Categoría	CORTADORA DE CESPED
Categorie	GRASMAAIMACHINE
Categoria	CORTADOR DE GRAMA
Kategori	GRÄSKLIPPARE
Kategori	GRESSKLIPPER
Kategori	GRÆSSLÅMASKINE
Kategoria	RUOHONLEIKKURI

Fabrikmarke / Make / Marque / Marca / Marca / Merk / Marca / Fabriksmärke / Merke / Mærke / Merkki	MURRAY
--	--------

Typ / Type / Type / Tipo / Tipo / Model / Tipo / Typ / Type / Type / Tyyppi	12,5 HP / 30
---	--------------

Garantierter Schalleistungspegel Guaranteed sound power level Niveau de puissance acoustique garanti Livello di potenza acustica garantito Nivel garantizado de potencia acústica Gewaarborgd niveau van geluidssterkte Nível de ruído motriz garantido Garanterad ljudstyrksnivå Garantert lydnivå Lydniveau garanti Taattu äänenvoiman taso	100 dB (A)
---	------------

Gemessener Schalleistungspegel Measured sound power level Niveau de puissance acoustique mesuré Livello di potenza acustica misurato Nivel medido de potencia acústica Gemeten niveau van geluidssterkte Nível de potencia acústica medido Uppmätt ljudstyrksnivå Mått lydnivå Mått lydniveau Mitattu äänentehotaso	98 dB (A)
---	-----------

Art der Schneidevorrichtung Type of cutting device Genre du dispositif de coupe Tipo di dispositivo di taglio Tipo de dispositivo de corte Soort snijmiddel Tipo de dispositivo cortante Typ av skäranordning Type klipperedskap Bladtype Leikkurityyppi	SICHELMESSER ROTATING BLADE LAME ROTATIVE LAMA ROTANTE CUCHILLA GIRATORIA ROTARENDE BLAD LÂMINA ROTATIVA ROTARENDE BLAD ROTARENDE BLAD ROTARENDE BLADE PYÖRIVÄ TERÄ
--	---

Schnittbreite / Width of cut / Largeur de coupe / Ampiezza di taglio / Ancho de corte / Snijbreedte / Extensão do corte / Skärbredd / Snittbredde / Skærebredde / Leikkuujäljen leveys	76 cm
--	-------

Name und Adresse der in der Europäischen Gemeinschaft etablierten benannten Stelle für Richtlinie 2000/14/EG

Name and address of the notified body established in the European Community for Directive 2000/14/EC

Nom et adresse de l'organisme notifié établi dans la Communauté européenne pour la directive 2000/14/CE

Nome e indirizzo dell'organismo notificato stabilito nella Comunità Europea per Direttiva 2000/14/CE

SNCH
11, Route de Luxembourg
L - 5230 Sandweiler

Nombre y dirección del organismo notificado establecido en la Comunidad Europea para la Directiva 2000/14/CE

Naam en adres van de aangemelde instantie gevestigd in de Europese Gemeenschap voor richtlijn 2000/14/EG

Nome e morada do organismo notificado na Comunidade Europeia para Directiva 2000/14/CE

Namn och adress på godkännande organ inom EU för föreskrift 2000/14/EG

Navn og adresse til godkjennende organ innen EU for direktivet 2000/14/EF

Navn og adresse på det bemyndigede organ, som er etableret i De Europæiske Fællesskaber for direktiv 2000/14/EF

Euroopan yhteisön alueella olevan ilmoitetun laitoksen nimi ja osoite direktiivin 2000/14/EY mukaisesti

Brentwood, TN USA 2002.12.05
 YYYY MM DD



Director, International Sales

(Ort und Datum der Ausstellung)
(Place and date of issue)
(Lieu et date)
(Luogo e data del rilascio)
(Lugar y fecha de expedición)
(Plaats en datum van de verklaring)
(Lugar e data de emissão)
(Utfärdat ort/datum)
(Sted og datum)
(Sted og dato)
(Ilmoitus annettu paikka ja päiväys)

(Name, Funktion und Unterschrift des Befugten)
(Name and job function of authorized person)
(Nom, fonction et signature de la personne autorisée)
(Nome, qualifica e firma dell'incaricato)
(Nombre, función y firma del encargado)
(Naam, functie en handtekening van bevoegd persoon)
(Nome, cargo e assinatura do responsável)
(Namn, befattning och underskrift av behörig medarbetare)
(Bemyndigtes navn, funksjon og underskrift)
(Bemyndigedes navn, funktion og underskrift)
(Valtuutetun henkilön nimi ja tehtävä)