



**CCR 2500E
CCR 2500E Int'l
SNOWTHROWER**

**Model No. 38425 - 7900001 & Up
Model No. 38426 - 7900001 & Up**

Parts Catalog

ORDERING REPLACEMENT PARTS

To order replacement parts, please supply: the part number, the quantity, and the description of each part desired.

Contents

Description	Page	Description	Page
Side Plate & Scraper Assembly	1	Engine Tecumseh Model No. HSK850	
Pulley & Cover Assembly	2	Type 8312B	9
Discharge Chute Assembly	3	Engine Tecumseh Model No. HSK850	
Rotor Assembly	4	Type 8312B	10
Engine & Fuel Tank Assembly	5	Recoil Starter Assembly No. 590712	11
Shroud Assembly	6	Recoil Starter Assembly No. 590743	
Handle Assembly	7	(Optional)	12
Carburetor Assembly No. 632751	8	Toro Part Number Index	13

Note:

Accessories

Description	Model / Parts No.	Description	Model / Parts No.
Snow Cab Kit	Part No. 88-0600		

Part Description Abbreviations

Part descriptions in this catalog may include the following abbreviations.

Abbreviation	Meaning	Abbreviation	Meaning
AR	as required	HWHTF	hex washer head thread forming
ASM	assembly	INC	incorporated
CARR	carriage	LH	left hand
DEG	degrees	PH	pan head
FH	flat head	PPH	Phillips pan head
GA	gauge	PTO	power take off
HF	hex flange	RH	right hand
HFW	hex flange washer	SFH	slotted fillister head
HH	hex head	SH	square head
HHF	hex head flange	SHWH	slotted hex washer head
HHST	hex head self tapping	SPH	slotted pan head
HJ	hex jam	STD	standard
HOC	height-of-cut	TAP	self tapping
HS	hex socket	TH	truss head
HSBH	hex socket button head	TTH	Torx truss head
HSFH	hex socket flat head	WH	wing head
HSH	hex socket head		
HWH	hex washer head		

Important Format Explanations

This catalog uses special formats to convey information in illustrations and parts lists. Specifically, one format is used in conjunction with service assemblies and another with quantities associated with reference numbers.

Service Assemblies

Parts within service assemblies have reference numbers in the form $X:Y$. X is the reference number of the service assembly and Y is a sequential number unique to each part within the service assembly.

For example, a wheel assembly might be identified by reference number 6, the tire by 6:1, the valve by 6:2, and the wheel by 6:3. When you order the assembly identified by reference number 6, you receive all parts identified by reference numbers 6:1, 6:2, and 6:3. However, you may also order any part individually.

Reference numbers of this type appear in part lists and as callouts in illustrations.

Reference Numbers with Quantities

Illustrations may have a quantity in parentheses next to a reference number, in the form $X (Y)$. X is the reference number. Y in parentheses is the quantity of the part identified by the reference number.

For example, the illustration callout 4 (2) indicates that two parts are used in that instance.

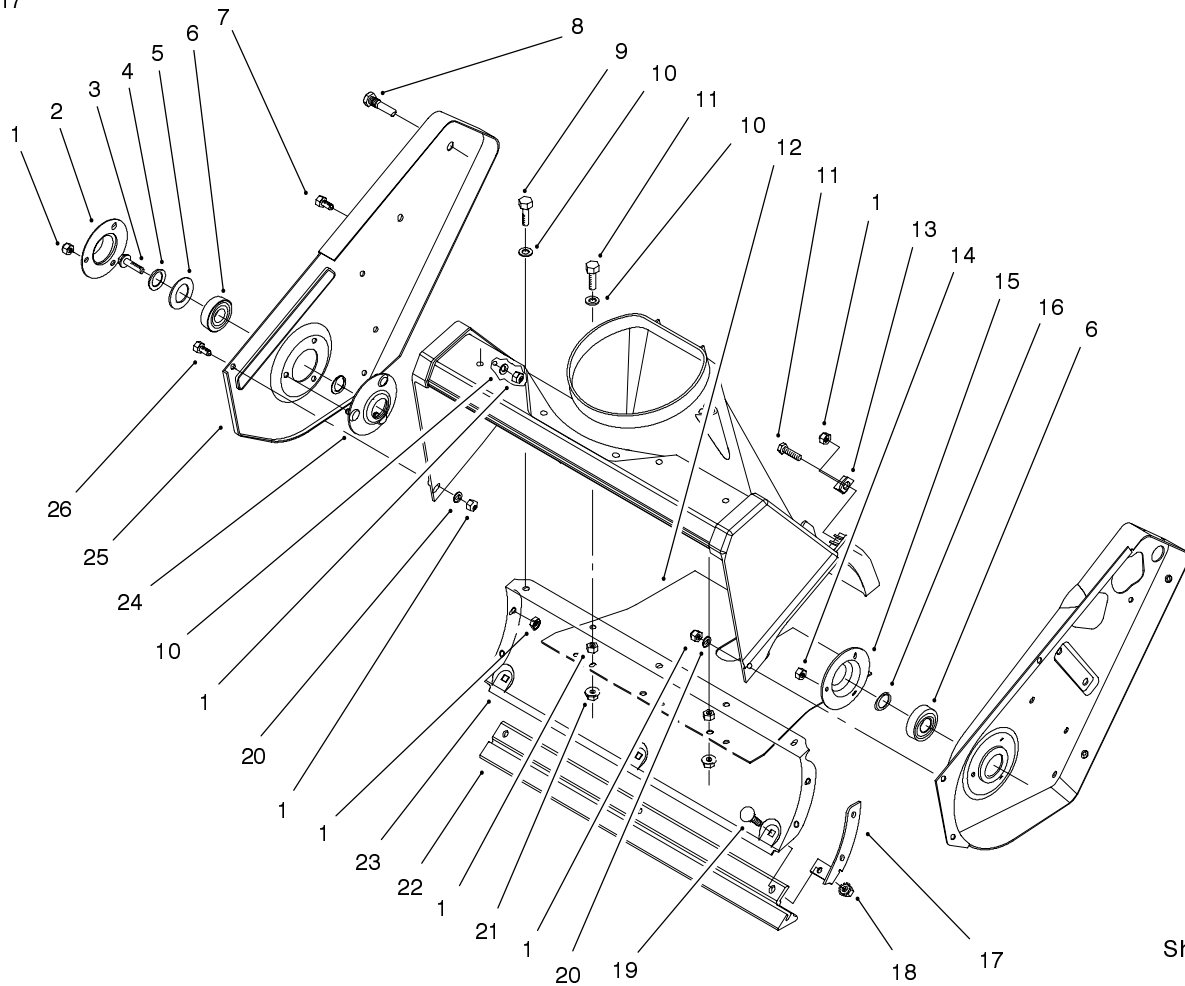

Sheet No.:2

Side Plate & Scraper Assembly

Ref. No.	Part No.	Qty.	Description
1	3296-42	16	Nut-Lock
2	52-7290	1	Retainer-Bearing
3	3234-25	1	Bolt-Flange
4	3256-24	1	Washer-Flat
5	52-7270	1	Washer-Rubber
6	38-7820	2	Bearing-Ball
7	322-43	1	Screw-HH
8	38-8211	1	Pin
9	321-4	3	Screw-HH
10	3256-22	7	Washer-Flat
11	321-6	3	Screw-HH
12	55-9512	1	Cover-Bottom
13	55-9430	1	"z" Bracket-Housing
14	3296-2	3	Nut Lock
15	38-8620	1	Retainer-Bearing
16	52-7280	2	Washer-Thrust
17	56-2610	1	Bracket-Housing
18	32149-2	3	Nut-Hex Lock Keps
19	3229-11	3	Bolt-CARR
20	3256-67	2	Washer-Flat
21	32128-10	2	Nut-Lock HHF
22	55-8760	1	Scraper
23	55-9220-01	1	Wa-Housing
24	52-9110	1	Wa-Bearing Flange
25	55-8840-01	1	Sideplate-RH

Ref. No.	Part No.	Qty.	Description
26	32105-15	5	Screw-HH

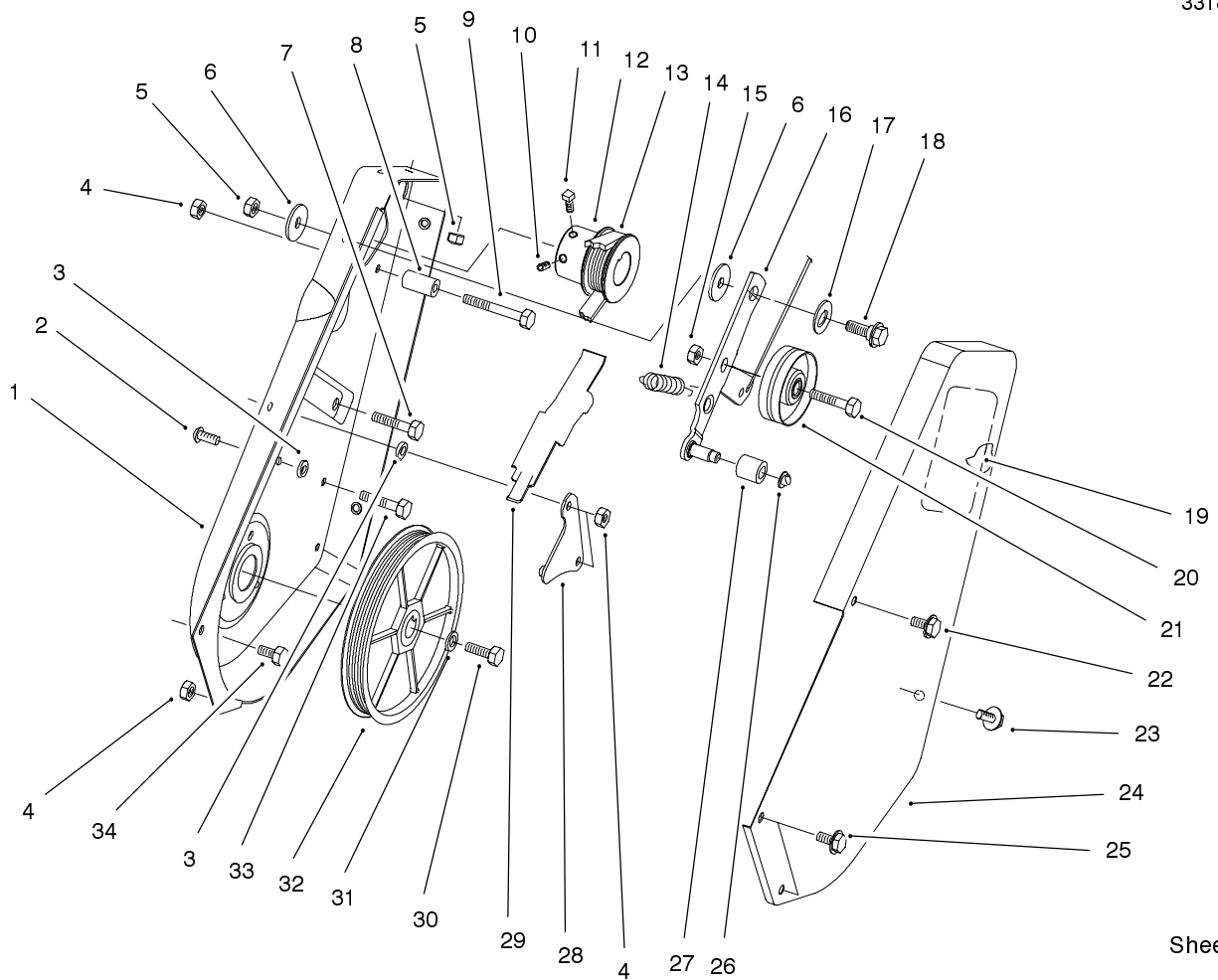

Sheet No.:3

Pulley & Cover Assembly

Ref. No.	Part No.	Qty.	Description
1	55-8851-01	1	Sideplate-LH
2	3274-31	1	Screw-HH
3	55-9620	2	Spacer
4	3296-42	5	Nut-Lock
5	3296-29	3	Nut-Lock
6	5-4460	2	Washer-Fender
7	322-3	2	Screw-HH
8	55-9530	1	Guide-Belt
9	321-13	1	Screw-HH
10	3245-41	1	Screw-Skt HH
11	3241-7	1	Screw-Sqh
12	55-9180	1	Pulley-Engine
13	55-9300	1	Belt-Drive
14	55-9280	1	Spring-Extension
15	32152-2	1	Nut-Lock HH
16	63-3610	1	ASM-Idler Arm
17	25-5640	1	Washer
18	27-0410	1	Bolt-Shoulder
19	60-9480	1	Decal-Routing
20	323-29	1	Screw-HH
21	55-9290	1	Pulley-Idler
22	36-3860	1	Screw-Pentaflor
23	12-3270	2	Screw-HH
24	55-9010-01	1	Cover-Drive
25	32105-15	2	Screw-HH
26	32112-11	1	Nut-Push

Ref. No.	Part No.	Qty.	Description
27	55-9520	1	Roller-Brake
28	55-9570	1	ASM-Pivot Plate
29	55-9550	1	Arm-Brake
30	321-30	1	Screw - HH
31	3290-456	1	Washer-Lock
32	60-9320	1	ASM-Pulley
33	321-4	2	Screw-HH
34	32105-8	3	Screw

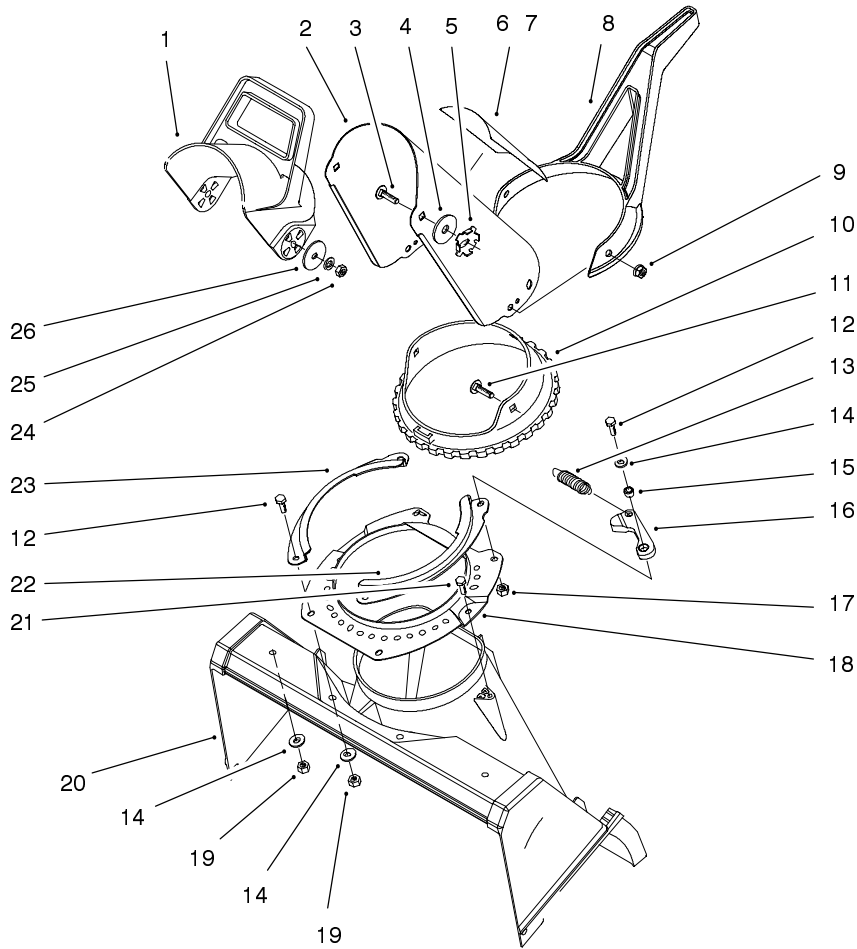

Sheet No.:4

Discharge Chute Assembly

Ref. No.	Part No.	Qty.	Description
1	56-2680	1	Deflector
2	94-2790	1	ASM-Chute & Decal(Serv) (Only On: 38425)
2	94-2791	1	ASM-Chute & Decal(Serv) (Only On: 38426)
3	3230-22	2	Screw-CARR
4	20-4320	2	Washer-Rubber
5	55-8950	2	Plate-Friction
6	94-2900	1	Decal-Danger (Only On: 38425)
7	94-2901	1	Decal-Danger (Only On: 38426)
8	94-9914	1	Handle-Chute Control
9	32149-1	3	Nut-Keps
10	71-4950	1	Ring-Chute
11	3230-18	3	Screw-CARR
12	321-4	4	Screw-HH
13	71-5590	1	Spring-Extension
14	3256-22	5	Washer-Flat
15	55-9370	1	Spacer-Rotor Blade
16	80-4610	1	Arm-Detent
17	3296-56	1	Nut-Hex Lock
18	55-8921-01	1	Ring-Chute Support
19	3296-42	5	Nut-Lock

Ref. No.	Part No.	Qty.	Description
20	55-8700	1	Housing
21	46-8092	2	Screw - Plastite
22	71-4980-01	1	Retainer-Chute Ring
23	71-4990-01	1	Retainer-Chute Ring
24	3296-29	2	Nut-Lock
25	3290-456	2	Washer-Lock
26	3256-68	2	Washer-Fit

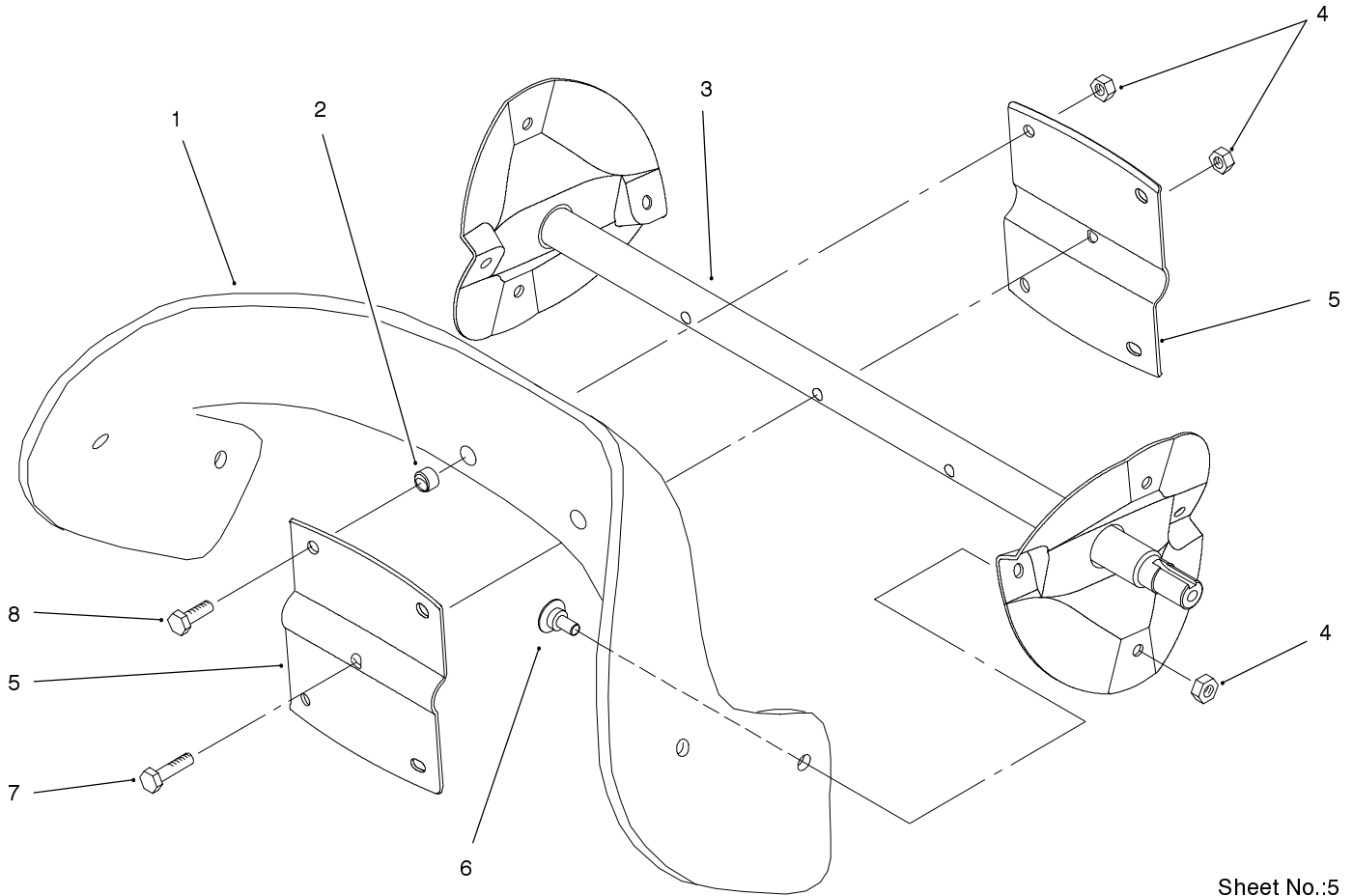

Sheet No.:5

Rotor Assembly

Ref. No.	Part No.	Qty.	Description
1	88-0771	2	Blade-Rotor
2	55-9370	4	Spacer-Rotor Blade
3	55-9202-01	1	Wa-Rotor
4	3296-56	12	Nut-Hex Lock
5	66-6600-01	2	Rotor
6	84-1971	8	Screw-Counter Sunk Oval
7	321-8	1	Screw-HH
8	321-4	4	Screw-HH

Ref. No.	Part No.	Qty.	Description

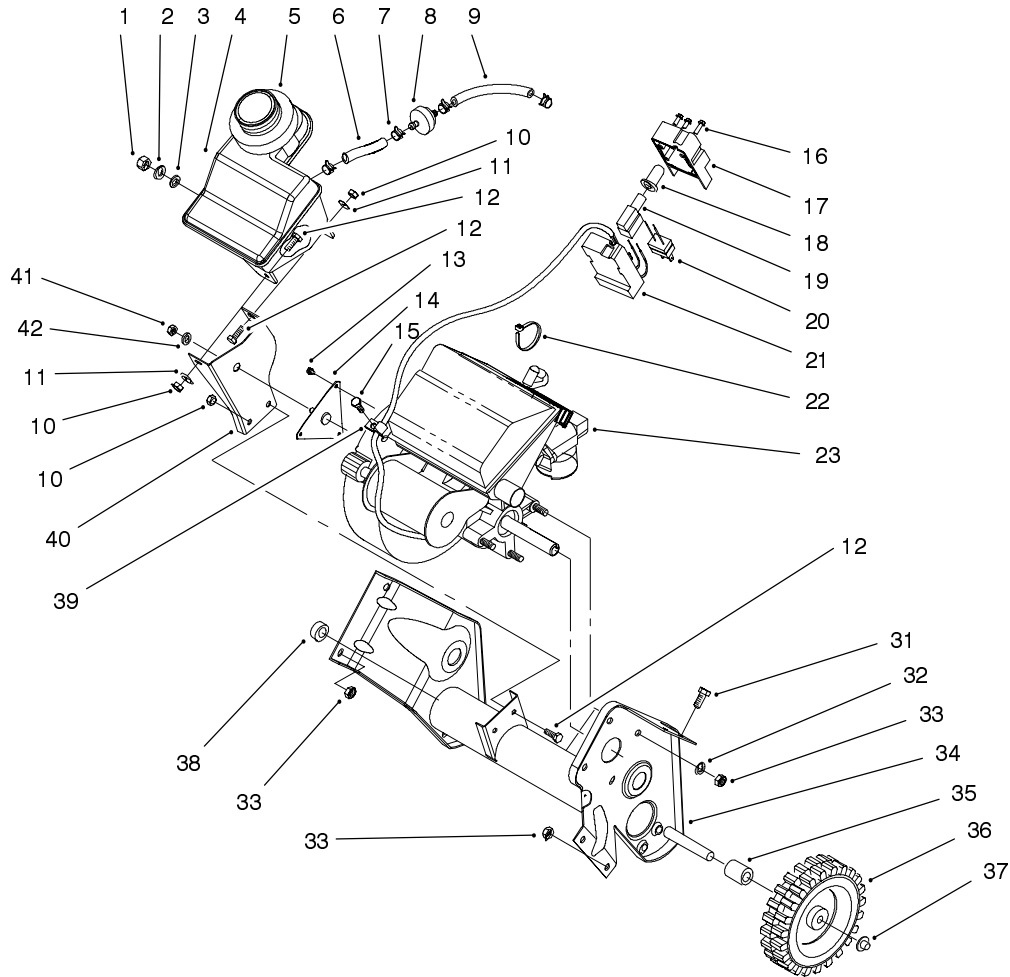

Sheet No.:6

Engine & Fuel Tank Assembly

Ref. No.	Part No.	Qty.	Description
1	32152-8	1	Nut - Top Deform
2	3256-23	1	Washer-Flat
3	237-89	1	Grommet
4	94-9920	1	Tank-Gas (Incl. Ref. #3)
5	55-9310	1	Seal-Tank
6	49-2482	1	Hose-Gas
7	2412-98	4	Clamp-Hose
8	56-6360	1	Filter-Fuel
9	94-9932	1	Hose-Gas
10	3296-42	4	Nut-Lock
11	3256-22	2	Washer-Flat
12	321-4	4	Screw-HH
13	92-6019	3	Screw-Thread Forming
14	92-6012	1	ASM-Bracket & Stud
15	32144-10	1	Screw-HH
16	32144-27	3	Screw
17	80-3740	1	Cap-Switch Housing
18	61-4810	1	Boot-Switch
19	61-4820	1	Switch-Starter
20	94-9933	1	Plug-Power
21	80-3730	1	Base-Switch Housing
22	250-4	1	Tie-Cable
23		1	Engine Assembly
31	322-3	2	Screw-HH

Ref. No.	Part No.	Qty.	Description
32	3290-456	5	Washer-Lock
33	3296-29	7	Nut-Lock
34	94-9917	1	Wa-Frame
35	66-6501	1	Spacer-Wheel
36	66-6510	2	Wheel
37	32112-14	2	Pushnut
38	66-6500	1	Spacer-Wheel
39	2412-91	1	Clamp-Cable
40	94-9918	1	Support-Recoil
41	3296-16	1	Nut-Lock
42	71-5320	1	Washer - Engine Support

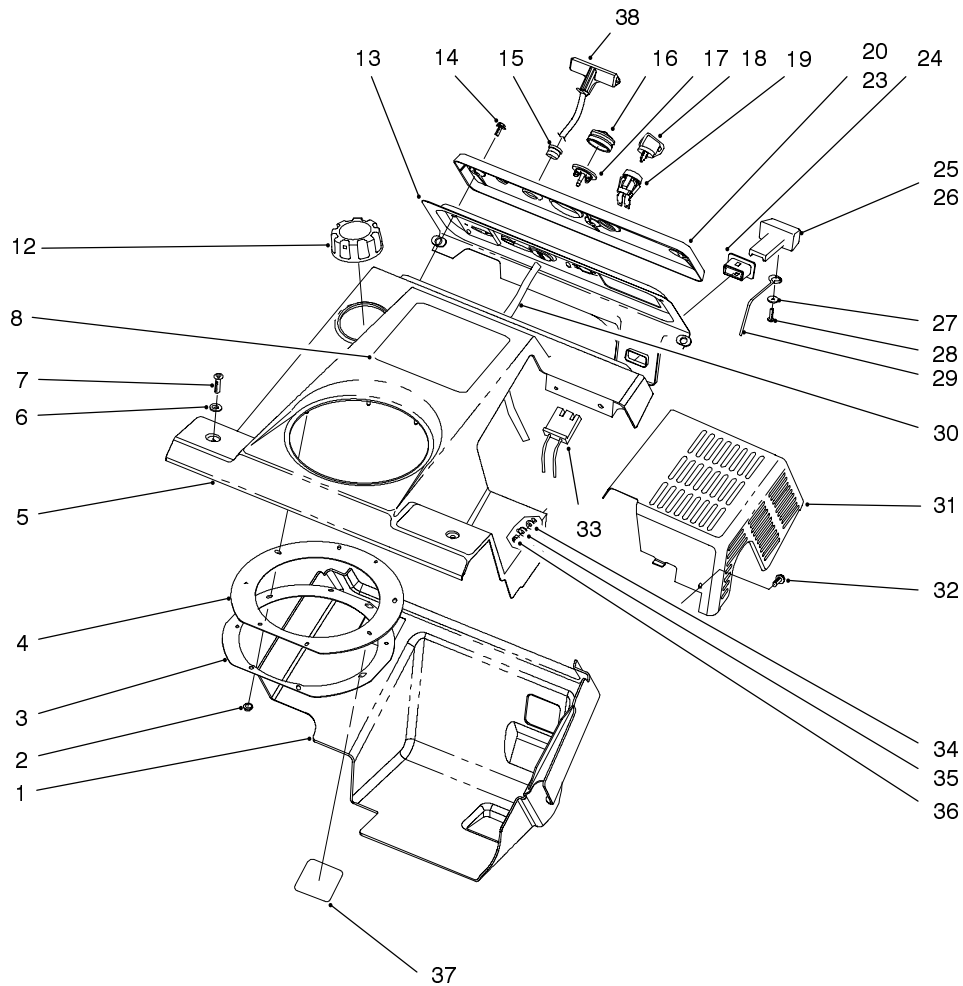

Sheet No.:7

Shroud Assembly

Ref. No.	Part No.	Qty.	Description	Ref. No.	Part No.	Qty.	Description
1	94-9919	1	Shroud-Lower	27	3256-49	1	Washer-Fit
2	3290-474	8	Pushnut-Arched Round	28	32144-111	1	Screw - PPH
3	55-9540-01	1	Retainer-Chute Seal	29	94-9921	1	Linkage-Choke
4	55-9260	1	Seal-Chute	30	44-3174	1	Hose-Primer
5	94-9925	1	Shroud-Upper	31	94-9924	1	Heat Shield Wa
6	3256-22	2	Washer-Flat	32	32105-8	3	Screw
7	3250-32	2	Screw-PPH	33	218-532	1	Connector
8	94-9910	1	Decal-Ccr2500e	34	55-9660	3	Washer-Rubber
12	55-3573	1	ASM-Gas Cap	35	3256-14	3	Washer-Flat
13	55-9490-01	1	Wa-Panel	36	3296-12	3	Nut-Lock
14	32144-112	3	Screw-Thd Form	37	61-4790	1	Decal-Warning (Csa) (E) (Only On: 38426)
15	55-9410	1	Guide-Starter Rope	38	92-4853	1	Handle-Starter
16	66-7460	1	Bulb-Primer				
17	44-2750	1	Body-Primer				
18	63-8360	1	Key-Ignition				
19	40-5940	1	Switch-Key				
20	94-2569	1	Plate-Name (Only On: 38426)				
23	61-4410	1	Nameplate-Control (Only On: 38425)				
24	55-8820	1	Fitting-Choke Control				
25	55-8811	1	Control-Choke Int'l (Only On: 38426)				
26	55-8810	1	Control-Choke (Only On: 38425)				

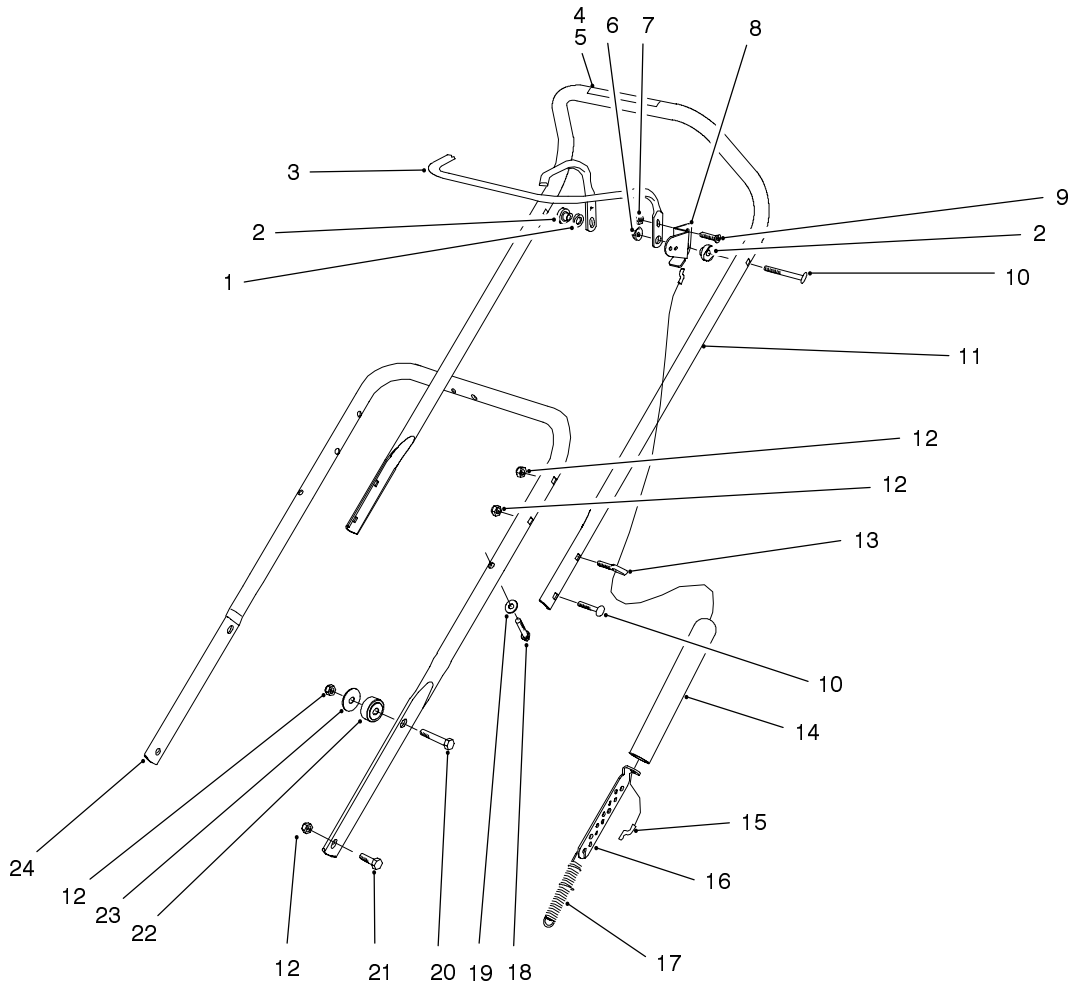

Sheet No.:8

Handle Assembly

Ref. No.	Part No.	Qty.	Description
1	55-9670	1	Washer-Rubber
2	55-9340	2	Spacer-Control Bar
3	55-9130-01	1	Bar-Control
4	66-6870	1	Decal-Rotor Drive (Only On: 38425)
5	94-2577	1	Decal-Rotor Drive (Only On: 38426)
6	32111-8	2	Nut Acorn
7	3296-42	1	Nut-Lock
8	55-9100-01	1	Arm-Clutch Cable
9	3274-31	1	Screw-HH
10	17-9424	5	Screw
11	94-2794	1	Upper Handle/Decal ASM (Only On: 38426)
11	95-2669	1	ASM-Handle (Only On: 38425)
12	3296-29	8	Nut-Lock
13	55-9420	1	Bolt - Eye
14	55-9390	1	Cover-Spring
15	55-9321	1	Cable-Clutch
16	55-9380	1	Adjuster-Clutch Cable
17	55-9270	1	Spring-Extension
18	61-8640	2	Screw - HH
19	3-7501	2	Washer-Curved
20	322-17	2	Screw-HH
21	322-3	2	Screw-HH

Ref. No.	Part No.	Qty.	Description
22	94-9923	2	Spacer-Lower Handle
23	3256-68	2	Washer-Fit
24	55-9121-01	1	Handle-Lower

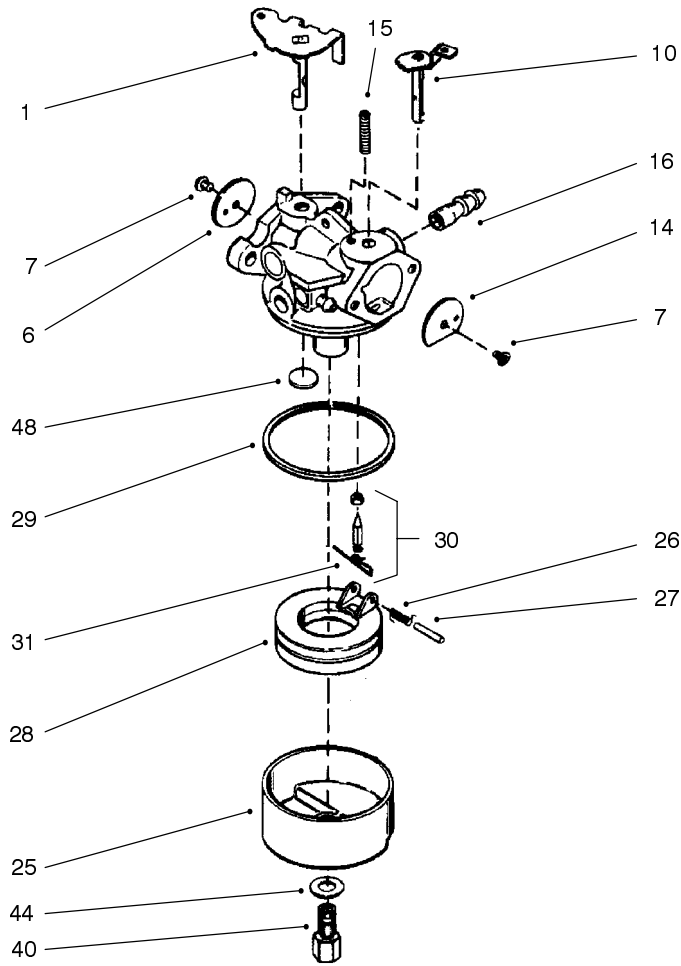

CARBURETOR ASSEMBLY NO. 632751

Ref. No.	Part No.	Description	No. Used	Ref. No.	Part No.	Description	No. Used
0	632751	Carburetor (Incl. 184 pg. 2)	1	26	632386	Float dampening Spring	1
1	632538	Throttle Shaft & Lever Assembly	1	27	631024	Float Shaft	1
6	631621	Throttle Shutter	1	28	632019	Float	1
7	650506	Shutter Screw	2	29	631028	Float Bowl "O" Ring	1
10	632752	Choke Shaft & Lever Assembly	1	30	631021	Inlet Needle, Seat & Clip (Incl. 31)	1
14	631815	Choke Shutter	1	31	631022	Spring Clip	1
15	630735	Choke Positioning Spring	1	40	632682	High Speed Bowl Nut	1
16	632164	Fuel Fitting	1	44	27110	Bowl Nut Washer	1
25	631867	Float Bowl	1	48	631027	Welch Plug, Atmospheric Vent	1

ENGINE TECUMSEH MODEL NO. HSK850 TYPE 8312B

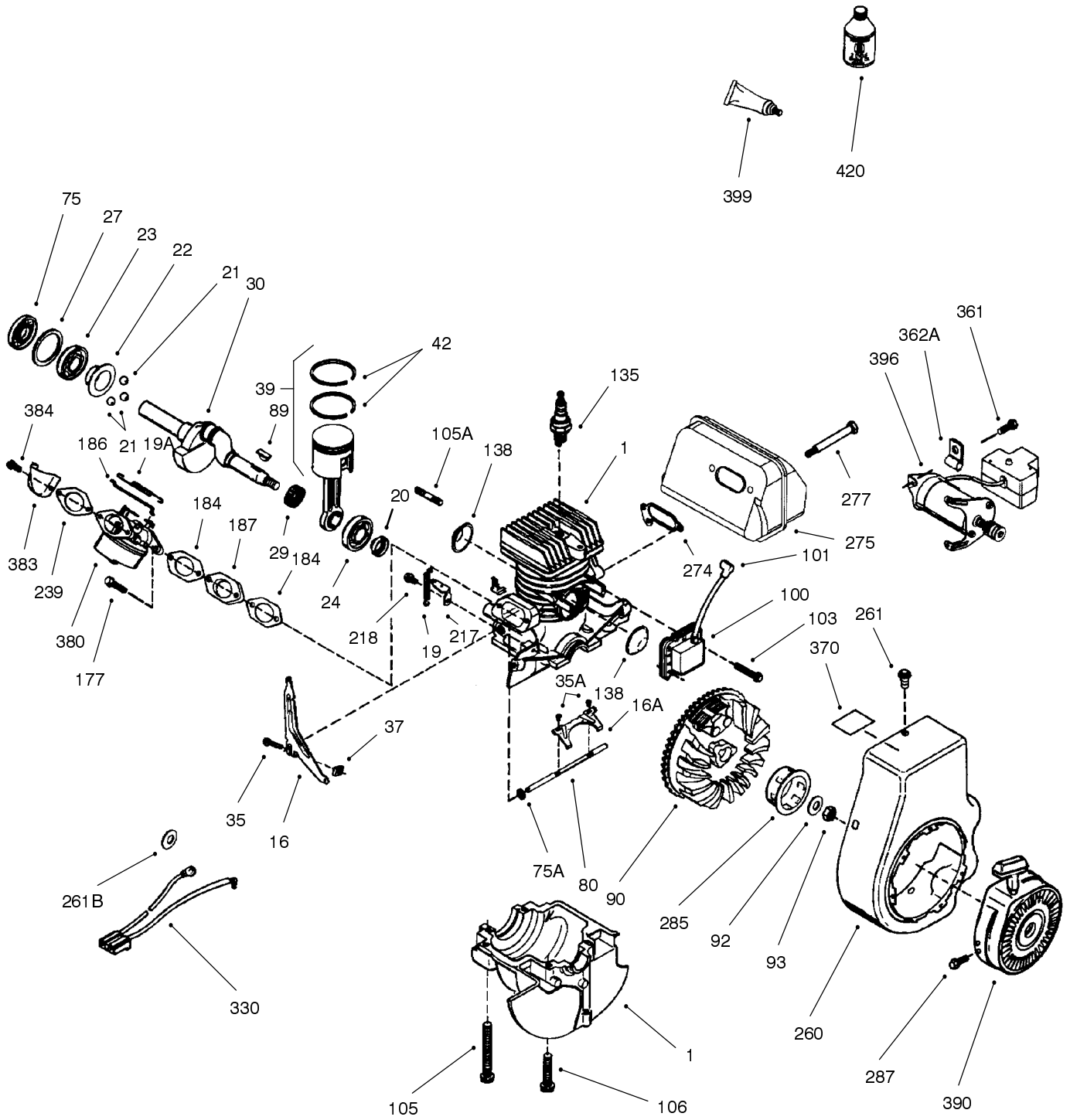

ENGINE TECUMSEH MODEL NO. HSK850 TYPE 8312B

Ref. No.	Part No.	Description	No. Used	Ref. No.	Part No.	Description	No. Used
	0	RPM High 3550 to 3850	0	184	510326A	Carburetor Gasket	2
	0	RPM Low 00	0	186	490319	Governor Link	1
1	250296A	Cylinder Ass'y (Incl. 75A, 105, 106, & 138)	1	187	570438A	Spacer	1
16	490317	Governor Lever	1	217	570667A	Control Lever	1
16A	490304	Governor Lever	1	218	650847	Screw	1
19	490325	Extension Spring	1	239	35815	Air Cleaner Gasket	1
19A	490318	Throttle Link Spring	1	260	350462	Blower Housing	1
20	510340	Oil Seal	1	261	650894	Screw	4
21	570673	Ball Bearing	3	261B	650890	Washer	1
22	510338	Slide Ring	1	274	510343A	Exhaust Gasket	1
23	530158	Ball Bearing	1	275	390342	Muffler	1
24	53-161	Ball Bearing	1	277	651021	Screw	2
27	530159	Bearing Retainer	1	285	34449A	Starter Cup	1
29	530164	Bearing Strip (31 Needles)	1	287	650926	Screw	3
30	290681	Crankshaft	1	325	29443	Wire Clip	1
35	29826	Screw	1	330	611217	Wire Harness	1
35A	650506	Screw	2	361	30063	Screw, Torx T-30	3
37	29216	Lock Nut	1	362A	430235	Extension Cord Clamp	1
39	310277B	Piston & Rod Ass'y (Incl. 29 & 42)	1	370	36261	Lubrication Decal	1
42	310278	Ring Set	1	380	632751	Carburetor (Incl. 184)	1
75	510339	Oil Seal	1	383	570695	Spit Cup	1
75A	510337	Oil Seal	1	384	650229	Screw, Torx T-25	2
80	490305	Governor Shaft	1	390	590712	Rewind Starter	1
89	611191	Flywheel Key	1			(Note: This engine could have been built with 590743 starter. Refer to the design of the rope pulley strength ribs for part identification. Individual starter parts do not interchange. Refer to Tecumseh service bulletin 116.)	
90	611192	Flywheel	1	396	590744	Electric Starter Motor (110V)	1
92	650815	Belleville Washer	1	399	510334	Gasket Eliminator (Loctite 515)	1
93	650816	Flywheel Nut	1	420	730227A	2-Cycle Oil (8 oz.)	1
100	34443A	Solid State Ignition	1				
101	610118	Spark Plug Cover	1				
103	651007	Screw, Torx T-15	2				
105	650892	Screw	2				
105A	650796	Stud	4				
106	650891	Screw	2				
135	611049	Resistor Spark Plug (RCJ8Y)	1				
138	570683	Port Cover	2				
177	650959	Screw - 5/32 Allen	2				

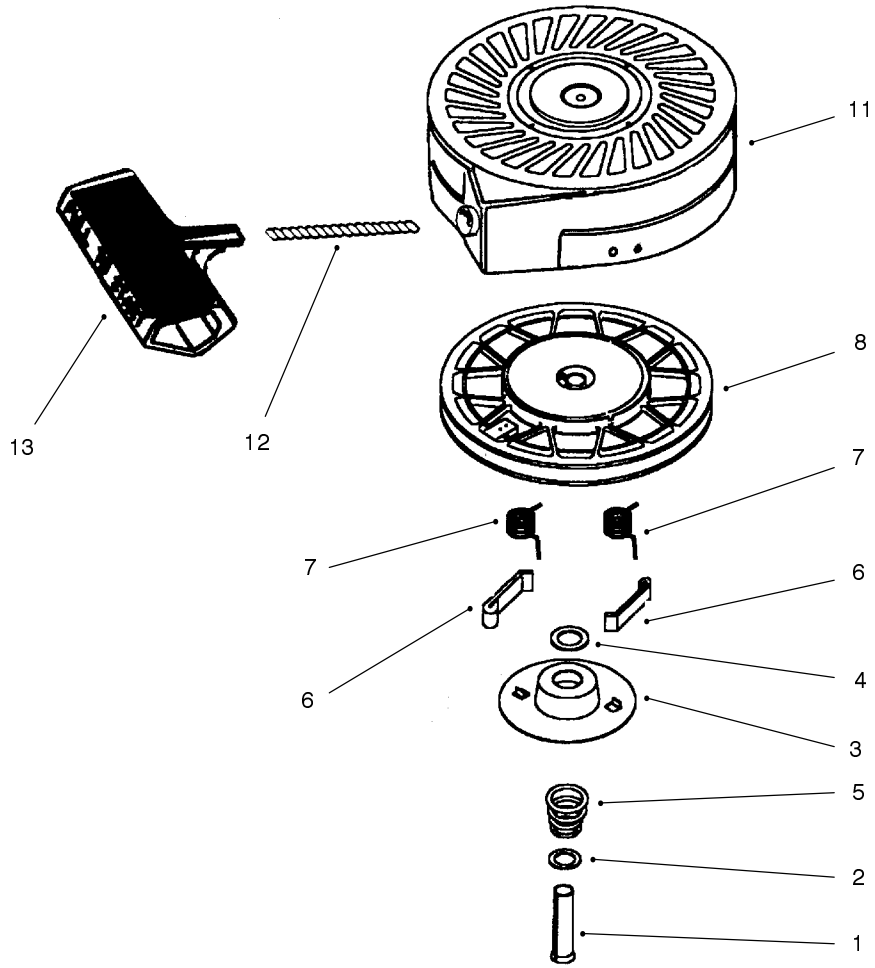

RECOIL STARTER ASSEMBLY NO. 590712

Ref. No.	Part No.	Description	No. Used
0	590712	Rewind Starter	1
1	590599A	Spring Pin (Incl. 4)	1
2	590600	Washer	1
3	590696	Retainer	1
4	590601	Washer	1
5	590697	Brake Spring	1
6	590698	Starter Dog	2

Ref. No.	Part No.	Description	No. Used
7	590699	Dog Spring	2
8	590709	Pulley & Rewind Spring Ass'y	1
11	590713	Starter Housing Ass'y	1
12	590535	Starter Rope (Length 98" x 9/64" Dia.)	1
13	590701	Starter Handle	1

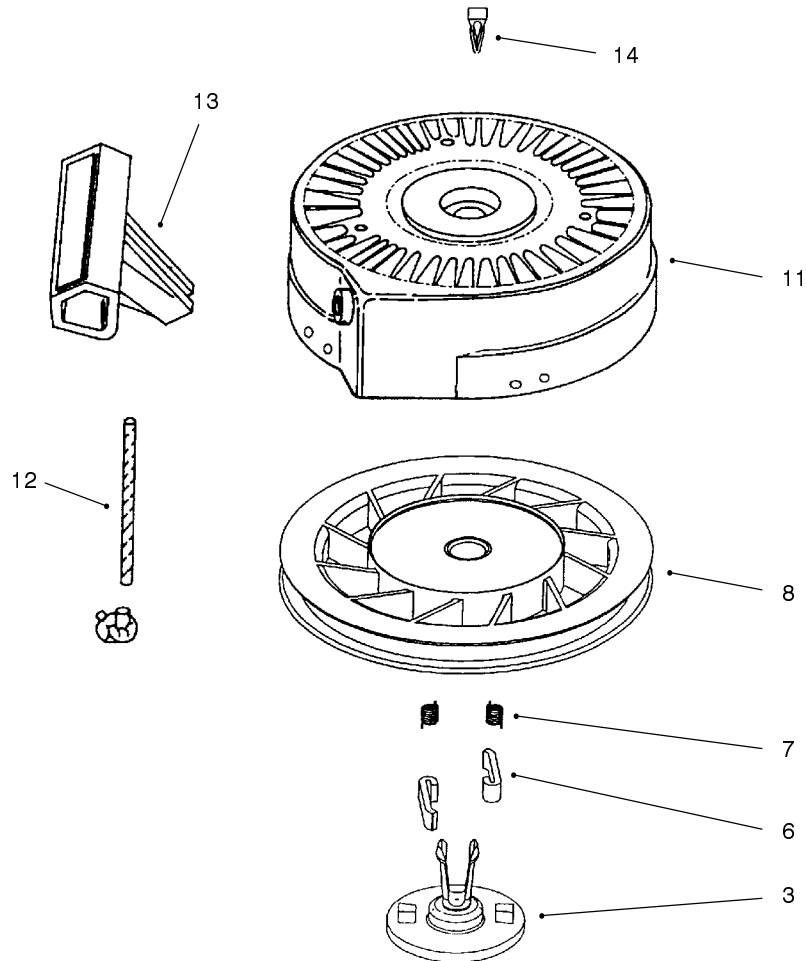

RECOIL STARTER ASSEMBLY NO. 590743 (OPTIONAL)

Ref. No.	Part No.	Description	No. Used	Ref. No.	Part No.	Description	No. Used
0	590743	Rewind Starter	1	11	590643	Starter Housing Ass'y	1
3	590740	Retainer	1	12	590535	Starter Rope (Length 98" x 9/64" Dia.)	1
6	590616	Starter Dog	2	13	590701	Starter Handle	1
7	590617	Dog Spring	2	14	590741	Locking Tab	1
8	590645A	Pulley & Rewind Spring Ass'y	1				

Toro Part Number Index

Part No.	Page No.	Ref. No.	Qty.	Description
	5	23	1	Engine Assembly
3-7501	7	19	2	Washer-Curved
5-4460	2	6	2	Washer-Fender
12-3270	2	23	2	Screw-HH
17-9424	7	10	5	Screw
20-4320	3	4	2	Washer-Rubber
25-5640	2	17	1	Washer
27-0410	2	18	1	Bolt-Shoulder
36-3860	2	22	1	Screw-Pentaflo
38-7820	1	6	2	Bearing-Ball
38-8211	1	8	1	Pin
38-8620	1	15	1	Retainer-Bearing
40-5940	6	19	1	Switch-Key
44-2750	6	17	1	Body-Primer
44-3174	6	30	1	Hose-Primer
46-8092	3	21	2	Screw - Plastite
49-2482	5	6	1	Hose-Gas
52-7270	1	5	1	Washer-Rubber
52-7280	1	16	2	Washer-Thrust
52-7290	1	2	1	Retainer-Bearing
52-9110	1	24	1	Wa-Bearing Flange
55-3573	6	12	1	ASM-Gas Cap
55-8700	3	20	1	Housing
55-8760	1	22	1	Scraper
55-8810	6	26	1	Control-Choke (Only On: 38425)
55-8811	6	25	1	Control-Choke Int'l (Only On: 38426)
55-8820	6	24	1	Fitting-Choke Control
55-8840-01	1	25	1	Sideplate-RH
55-8851-01	2	1	1	Sideplate-LH
55-8921-01	3	18	1	Ring-Chute Support
55-8950	3	5	2	Plate-Friction
55-9010-01	2	24	1	Cover-Drive
55-9100-01	7	8	1	Arm-Clutch Cable
55-9121-01	7	24	1	Handle-Lower
55-9130-01	7	3	1	Bar-Control
55-9180	2	12	1	Pulley-Engine
55-9202-01	4	3	1	Wa-Rotor
55-9220-01	1	23	1	Wa-Housing
55-9260	6	4	1	Seal-Chute
55-9270	7	17	1	Spring-Extension
55-9280	2	14	1	Spring-Extension
55-9290	2	21	1	Pulley-Idler
55-9300	2	13	1	Belt-Drive
55-9310	5	5	1	Seal-Tank
55-9321	7	15	1	Cable-Clutch
55-9340	7	2	2	Spacer-Control Bar
55-9370	3	15	1	Spacer-Rotor Blade
55-9370	4	2	4	Spacer-Rotor Blade
55-9380	7	16	1	Adjuster-Clutch Cable
55-9390	7	14	1	Cover-Spring
55-9410	6	15	1	Guide-Starter Rope
55-9420	7	13	1	Bolt - Eye
55-9430	1	13	1	"z" Bracket-Housing
55-9490-01	6	13	1	Wa-Panel
55-9512	1	12	1	Cover-Bottom
55-9520	2	27	1	Roller-Brake
55-9530	2	8	1	Guide-Belt
55-9540-01	6	3	1	Retainer-Chute Seal
55-9550	2	29	1	Arm-Brake
55-9570	2	28	1	ASM-Pivot Plate
55-9620	2	3	2	Spacer
55-9660	6	34	3	Washer-Rubber
55-9670	7	1	1	Washer-Rubber

*Not Illustrated

Toro Part Number Index (cont.)

Part No.	Page No.	Ref. No.	Qty.	Description
56-2610	1	17	1	Bracket-Housing
56-2680	3	1	1	Deflector
56-6360	5	8	1	Filter-Fuel
60-9320	2	32	1	ASM-Pulley
60-9480	2	19	1	Decal-Routing
61-4410	6	23	1	Nameplate-Control (Only On: 38425)
61-4790	6	37	1	Decal-Warning (Csa) (E) (Only On: 38426)
61-4810	5	18	1	Boot-Switch
61-4820	5	19	1	Switch-Starter
61-8640	7	18	2	Screw - HH
63-3610	2	16	1	ASM-Idler Arm
63-8360	6	18	1	Key-Ignition
66-6500	5	38	1	Spacer-Wheel
66-6501	5	35	1	Spacer-Wheel
66-6510	5	36	2	Wheel
66-6600-01	4	5	2	Rotor
66-6870	7	4	1	Decal-Rotor Drive (Only On: 38425)
66-7460	6	16	1	Bulb-Primer
71-4950	3	10	1	Ring-Chute
71-4980-01	3	22	1	Retainer-Chute Ring
71-4990-01	3	23	1	Retainer-Chute Ring
71-5320	5	42	1	Washer - Engine Support
71-5590	3	13	1	Spring-Extension
80-3730	5	21	1	Base-Switch Housing
80-3740	5	17	1	Cap-Switch Housing
80-4610	3	16	1	Arm-Detent
84-1971	4	6	8	Screw-Counter Sunk Oval
88-0771	4	1	2	Blade-Rotor
92-4853	6	38	1	Handle-Starter
92-6012	5	14	1	ASM-Bracket & Stud
92-6019	5	13	3	Screw-Thread Forming
94-2569	6	20	1	Plate-Name (Only On: 38426)
94-2577	7	5	1	Decal-Rotor Drive (Only On: 38426)
94-2790	3	2	1	ASM-Chute & Decal(Serv) (Only On: 38425)
94-2791	3	2	1	ASM-Chute & Decal(Serv) (Only On: 38426)
94-2794	7	11	1	Upper Handle/Decal ASM (Only On: 38426)
94-2900	3	6	1	Decal-Danger (Only On: 38425)
94-2901	3	7	1	Decal-Danger (Only On: 38426)
94-9910	6	8	1	Decal-Ccr2500e
94-9914	3	8	1	Handle-Chute Control
94-9917	5	34	1	Wa-Frame
94-9918	5	40	1	Support-Recoil
94-9919	6	1	1	Shroud-Lower
94-9920	5	4	1	Tank-Gas
94-9921	6	29	1	Linkage-Choke
94-9923	7	22	2	Spacer-Lower Handle
94-9924	6	31	1	Heat Shield Wa
94-9925	6	5	1	Shroud-Upper
94-9932	5	9	1	Hose-Gas
94-9933	5	20	1	Plug-Power
95-2669	7	11	1	ASM-Handle (Only On: 38425)
218-532	6	33	1	Connector
237-89	5	3	1	Grommet
2412-91	5	39	1	Clamp-Cable
2412-98	5	7	4	Clamp-Hose
250-4	5	22	1	Tie-Cable
321-4	1	9	3	Screw-HH
321-4	2	33	2	Screw-HH
321-4	3	12	4	Screw-HH
321-4	4	8	4	Screw-HH
321-4	5	12	4	Screw-HH
321-6	1	11	3	Screw-HH
321-8	4	7	1	Screw-HH

*Not Illustrated

Toro Part Number Index (cont.)

Part No.	Page No.	Ref. No.	Qty.	Description
321-13	2	9	1	Screw-HH
321-30	2	30	1	Screw - HH
322-3	2	7	2	Screw-HH
322-3	5	31	2	Screw-HH
322-3	7	21	2	Screw-HH
322-17	7	20	2	Screw-HH
322-43	1	7	1	Screw-HH
323-29	2	20	1	Screw-HH
3229-11	1	19	3	Bolt-CARR
3230-18	3	11	3	Screw-CARR
3230-22	3	3	2	Screw-CARR
3234-25	1	3	1	Bolt-Flange
3241-7	2	11	1	Screw-Sqh
3245-41	2	10	1	Screw-Skt HH
3250-32	6	7	2	Screw-PPH
3256-14	6	35	3	Washer-Flat
3256-22	1	10	7	Washer-Flat
3256-22	3	14	5	Washer-Flat
3256-22	5	11	2	Washer-Flat
3256-22	6	6	2	Washer-Flat
3256-23	5	2	1	Washer-Flat
3256-24	1	4	1	Washer-Flat
3256-49	6	27	1	Washer-Flt
3256-67	1	20	2	Washer-Flat
3256-68	3	26	2	Washer-Flt
3256-68	7	23	2	Washer-Flt
3274-31	2	2	1	Screw-HH
3274-31	7	9	1	Screw-HH
3290-456	2	31	1	Washer-Lock
3290-456	3	25	2	Washer-Lock
3290-456	5	32	5	Washer-Lock
3290-474	6	2	8	Pushnut-Arched Round
3296-2	1	14	3	Nut Lock
3296-12	6	36	3	Nut-Lock
3296-16	5	41	1	Nut-Lock
3296-29	2	5	3	Nut-Lock
3296-29	3	24	2	Nut-Lock
3296-29	5	33	7	Nut-Lock
3296-29	7	12	8	Nut-Lock
3296-42	1	1	16	Nut-Lock
3296-42	2	4	5	Nut-Lock
3296-42	3	19	5	Nut-Lock
3296-42	5	10	4	Nut-Lock
3296-42	7	7	1	Nut-Lock
3296-56	3	17	1	Nut-Hex Lock
3296-56	4	4	12	Nut-Hex Lock
32105-8	2	34	3	Screw
32105-8	6	32	3	Screw
32105-15	1	26	5	Screw-HH
32105-15	2	25	2	Screw-HH
32111-8	7	6	2	Nut Acorn
32112-11	2	26	1	Nut-Push
32112-14	5	37	2	Pushnut
32128-10	1	21	2	Nut-Lock HHF
32144-10	5	15	1	Screw-HH
32144-27	5	16	3	Screw
32144-111	6	28	1	Screw - PPH
32144-112	6	14	3	Screw-Thd Form
32149-1	3	9	3	Nut-Keps
32149-2	1	18	3	Nut-Hex Lock Keps
32152-2	2	15	1	Nut-Lock HH
32152-8	5	1	1	Nut - Top Deform

*Not Illustrated

