



1438HXL LAWN TRACTOR

Model No. 71215 – 7900001 & Up

Parts Catalog

ORDERING REPLACEMENT PARTS

To order replacement parts, please supply: the part number, the quantity, and the description of each part desired.

Contents

Description	Page	Description	Page
Frame Assembly	1	Pulley & Belt Assembly (38" Cutting Unit)	12
Hood Assembly	2	Suspension Assembly (38" Cutting Unit)	13
Seat Assembly	3	Height Of Cut Assembly	14
Front Axle Assembly	4	Electrical Assembly	15
Steering Assembly	5	Electrical Schematic	16
Engine & Gas Tank Assembly	6	Engine Briggs & Stratton	
Clutch Assembly	7	Model 28N707-0631-A1	17-25
Rear Wheel Assembly	8	Toro Part Number Index	26-32
Transaxle Assembly	9	Maintenance	33
Speed Control Assembly	10		
Deck Assembly (38" Cutting Unit)	11		

Note:

Accessories

Description	Model / Parts No.	Description	Model / Parts No.
Easy Empty Bagger	Model No. 79116 or Model No. 79117	Tire Chains	Part No. 11-0430
Twin Bag Bagger Kit	Model No. 79101 or Model No. 79103	Headlight Kit	Model No. 79180
Recycler Kit (Std. on 71193)	Model No. 79170	42" Snowblade Kit	Model No. 79150
Hi-Sail Bagging Blade	Part No. 57-4700	Wheel Weight Kit	Model No. 59159
		Anti-Scalp Kit	Model No. 79182

Part Description Abbreviations

Part descriptions in this catalog may include the following abbreviations.

Abbreviation	Meaning	Abbreviation	Meaning
AR	as required	HSH	hex socket head
ASM	assembly	HWH	hex washer head
CARR	carriage	HWHTF	hex washer head thread forming
DEG	degrees	INC	incorporated
FH	flat head	LH	left hand
GA	gauge	PH	pan head
HF	hex flange	PPH	Phillips pan head
HFW	hex flange washer	PTO	power take off
HH	hex head	RH	right hand
HHF	hex head flange	SFH	slotted fillister head
HHST	hex head self tapping	SH	square head
HJ	hex jam	SHWH	slotted hex washer head
HOC	height-of-cut	SPH	slotted pan head
HS	hex socket	STD	standard
HSBH	hex socket button head	TAP	self tapping
HSFH	hex socket flat head		

TH truss head
 TTH Torx truss head

WH wing head

Important Format Explanations

This catalog uses special formats to convey information in illustrations and parts lists. Specifically, one format is used in conjunction with service assemblies and another with quantities associated with reference numbers.

Service Assemblies

Parts within service assemblies have reference numbers in the form $X:Y$. X is the reference number of the service assembly and Y is a sequential number unique to each part within the service assembly.

For example, a wheel assembly might be identified by reference number 6, the tire by 6:1, the valve by 6:2, and the wheel by 6:3. When you order the assembly identified by reference number 6, you receive all parts identified by reference numbers 6:1, 6:2, and 6:3. However, you may also order any part individually.

Reference numbers of this type appear in part lists and as callouts in illustrations.

Reference Numbers with Quantities

Illustrations may have a quantity in parentheses next to a reference number, in the form $X (Y)$. X is the reference number. Y in parentheses is the quantity of the part identified by the reference number.

For example, the illustration callout 4 (2) indicates that two parts are used in that instance.

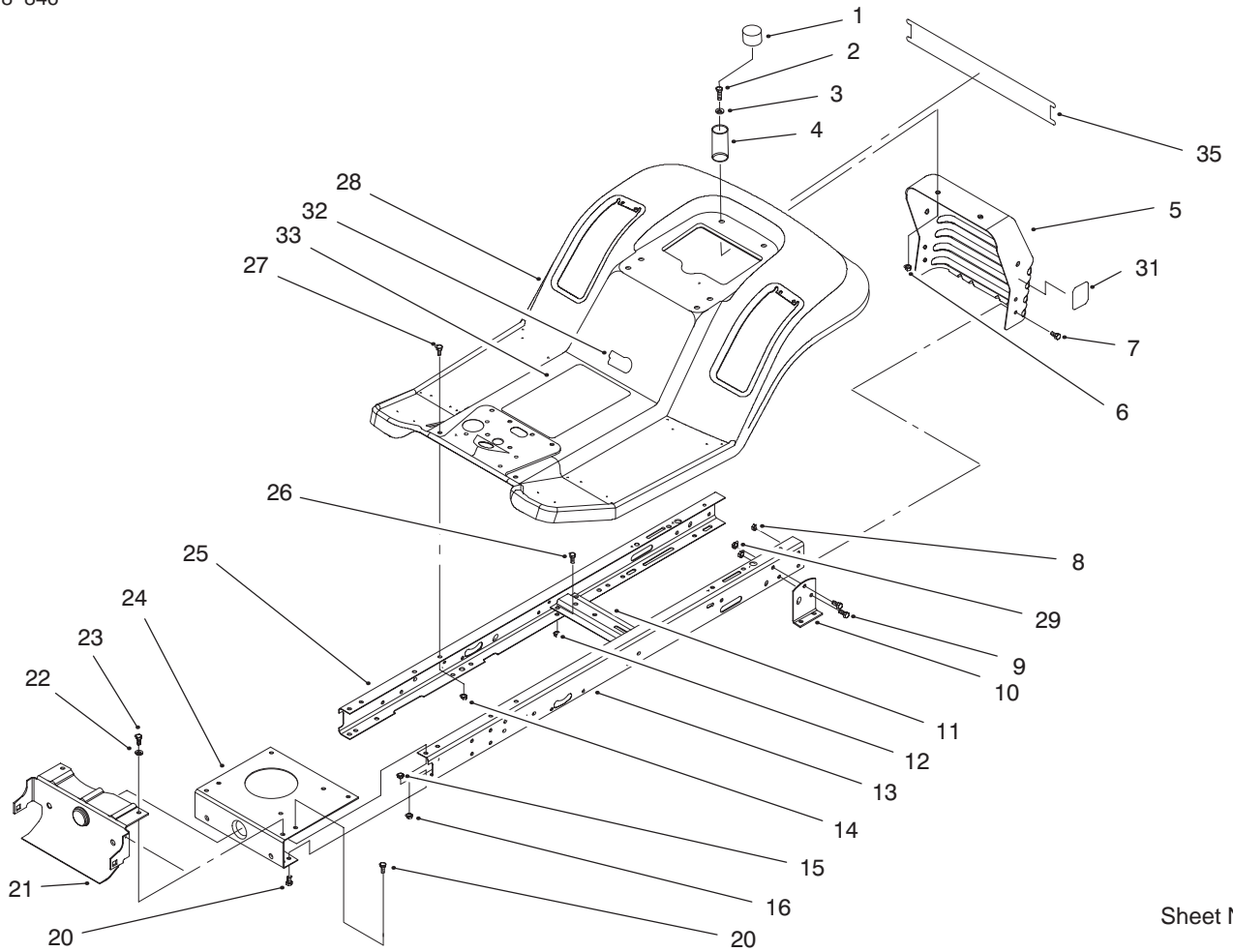

Sheet No.:2

Frame Assembly

Ref. No.	Part No.	Qty.	Description
1	701178	2	Cap-Protector
2	322-5	2	Screw-HH
3	3256-23	2	Washer-Flat
4	88-6220	2	Spring - Compression
5	88-3940-03	1	Panel - Rear
6	3296-29	2	Nut-Lock
7	322-3	4	Screw-HH
8	3296-29	4	Nut-Lock
9	322-3	4	Screw-HH
10	88-5260-03	2	Bracket-Transaxle Mounti
11	88-4620-03	1	Bracket - Idler Pivot
12	3296-29	4	Nut-Lock
13	94-1999-03	1	Frame Rail-LH
14	3296-29	2	Nut-Lock
15	3296-29	6	Nut-Lock
16	3296-29	2	Nut-Lock
20	322-3	6	Screw-HH
21	88-5120-03	1	Support - Front Axle
22	3256-23	2	Washer-Flat
23	322-3	2	Screw-HH
24	88-4630-03	1	Plate - Engine Mounting
25	94-1998-03	1	Frame Rail-RH
26	322-3	4	Screw-HH
27	322-3	2	Screw-HH

Ref. No.	Part No.	Qty.	Description
28	88-3840	1	Body - Rear
29	3296-29	4	Nut-Lock
31	93-6678	1	Decal - Dump Valve
32	76-1340	1	Decal-USA
33	94-1238	1	Decal-Instruction
35	94-3529	1	Decal-Rear Body

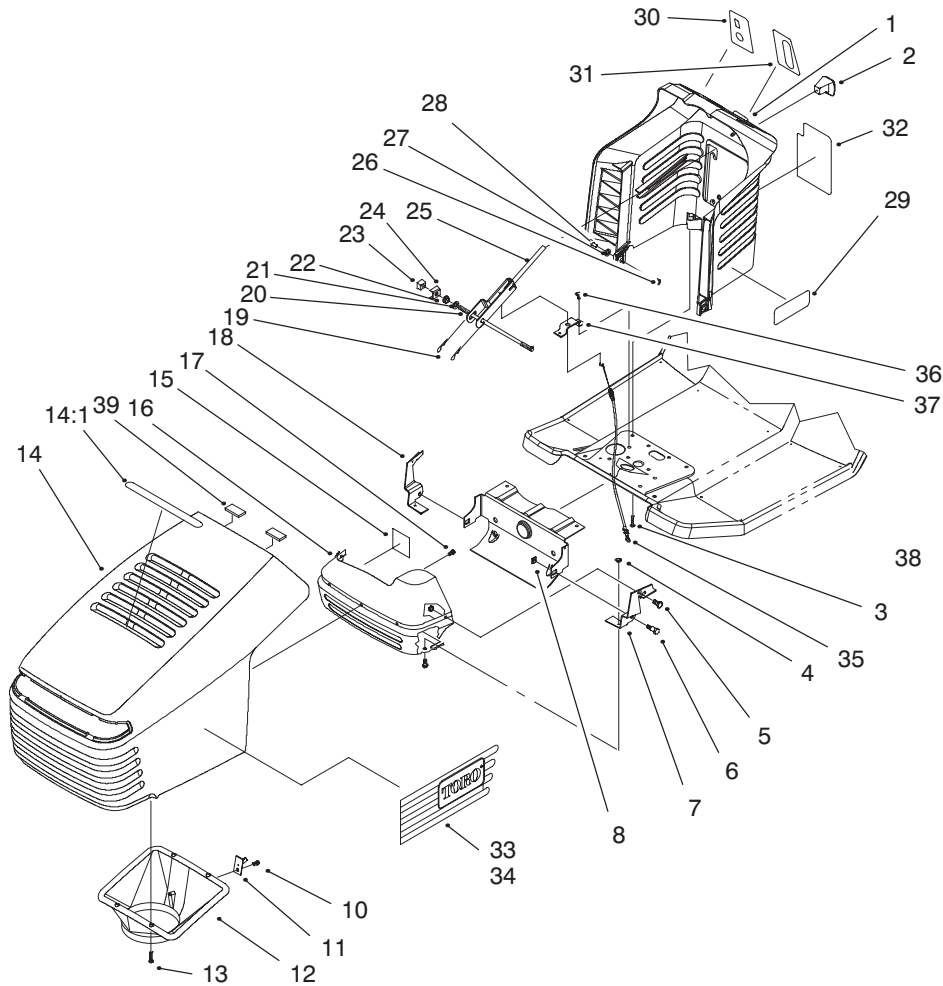

Sheet No.:3

Hood Assembly

Ref. No.	Part No.	Qty.	Description
1	93-0303	1	Tower-Steering Toro
2	94-5565	1	Knob - Control
3	46-8091	2	Screw-Tapping
4	3296-42	4	Nut-Lock
5	321-2	4	Screw-HH
6	28-0540	2	Bolt-Shoulder
7	88-6050-03	1	Bracket - Hinge
8	3290-496	2	Nut - Retained
10	46-8091	1	Screw-Tapping
11	94-1984	1	Pin-Latch
12	88-4050	1	Duct - Hood Air
13	46-8090	4	Screw-Tapping
14	92-8650	1	Hood-Toro
14:1	92-5748	1	Decal - Air Duct
15	92-5782	1	Patch - Heat Tape
16	93-3864	1	Shield - Heat
17	46-8090	3	Screw-Tapping
18	88-6040-03	1	Bracket - Hinge
19	3290-307	2	Pin-Cotter
20	88-4170	1	Rod - Pivot
21	3256-24	2	Washer-Flat
22	32128-43	2	Nut-Flange
23	88-4140	2	Nut - Wedge
24	88-4160	2	Clamp - Pivot Rod
25	88-5190-03	1	Lever W.a. - Deck Engage

Ref. No.	Part No.	Qty.	Description
26	3296-29	2	Nut-Lock
27	3256-23	2	Washer-Flat
28	322-3	2	Screw-HH
29	94-3527	2	Decal-Tower
30	92-2460	1	Decal - Ignition/Lights
31	92-2461	1	Decal - Throttle
32	92-2462	1	Decal - Deck Engage
33	92-2468	1	Decal - Hood Left
34	92-2467	1	Decal - Hood Right
35	94-4293	1	Cable ASM-Deck Engage
36	9266714	2	Screw-HWHTF
37	93-3849	1	Brkt-Cable
39	94-1980	2	Foam-Hood

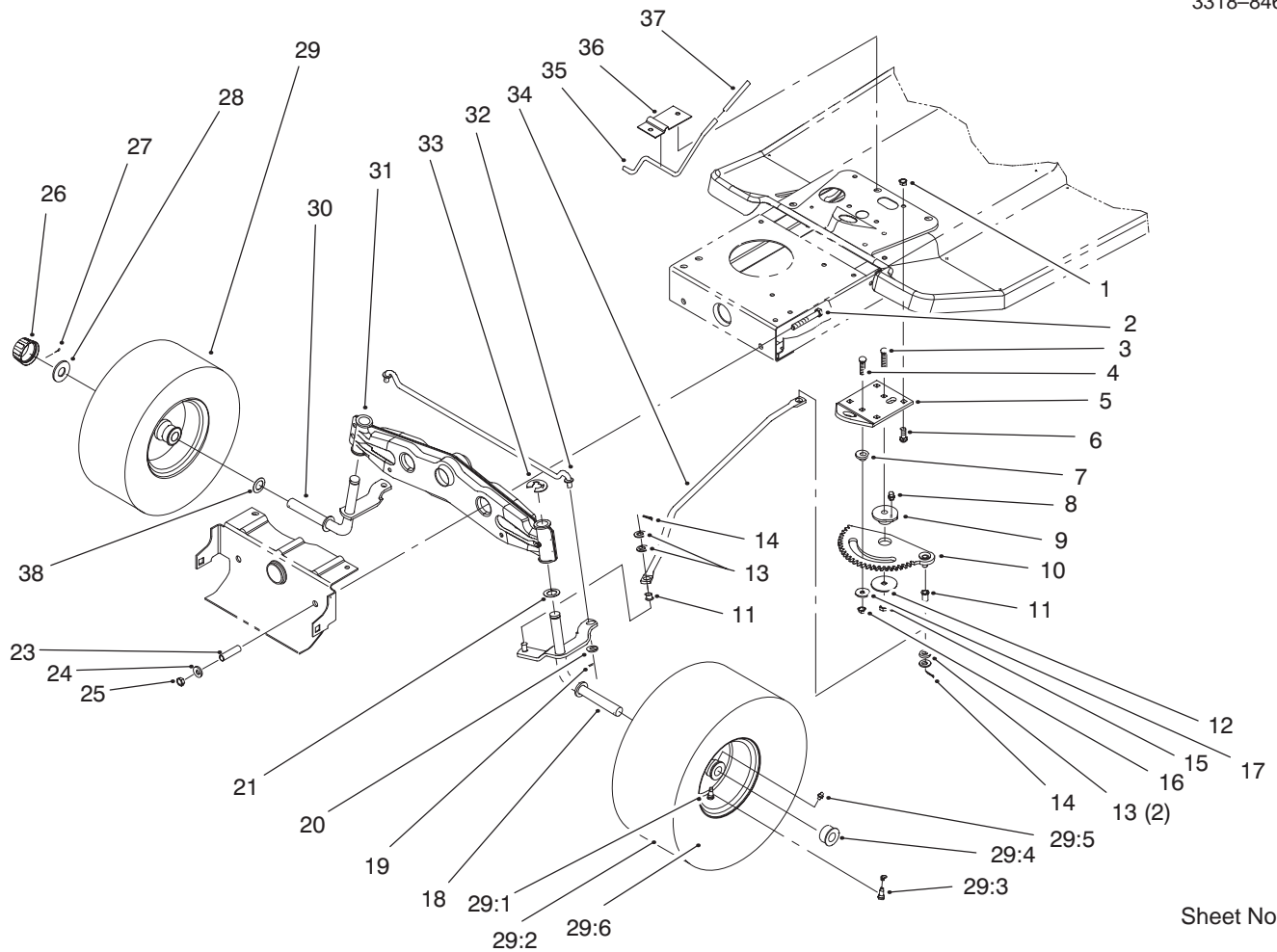

Sheet No.:5

Front Axle Assembly

Ref. No.	Part No.	Qty.	Description
1	3296-29	4	Nut-Lock
2	323-13	2	Screw-HH
3	3231-4	1	Bolt-CARR
4	3230-3	1	Screw-CARR
5	88-5130-03	1	Bracket - Steering Rack
6	3230-1	4	Bolt-CARR
7	88-5010	1	Spacer - Steering Rack
8	302-26	1	Fitting-Grease
9	88-4670	1	Bushing - Eccentric
10	88-5200	1	Steering Rack W.a.
11	52-2891	2	Bushing - Steering Links
12	111419	1	Washer-Bearing
13	3256-25	4	Washer-Flt
14	3272-10	2	Pin-Cotter
15	3296-39	1	Nut-Lock
16	3296-29	1	Nut-Lock
17	5-4460	1	Washer-Fender
18	92-7890-03	1	Spindle Wa-LH
19	3272-10	2	Pin-Cotter
20	3256-24	2	Washer-Flat
21	3-6498	2	Washer-Thrust
23	88-5470	2	Spacer - Front Axle
24	3256-24	2	Washer-Flat

Ref. No.	Part No.	Qty.	Description
25	3296-39	2	Nut-Lock
26	61-9780	2	Hubcap
27	3272-12	2	Pin-Cotter
28	28-2480	2	Washer-Flat
29	88-4280	2	Front Wheel & Tire ASM
29:1	88-4370	2	Rim ASM - 15" Front
29:2	88-4070	2	Tire 15 X 6.00-6
29:3	232-27	2	Valve Stem & Cap Assembly
29:4	88-4400	2	Bearing - Wheel
29:5	302-5	2	Fitting - Grease
29:6	232-39	2	Tube - Inner 15 X 6-6
30	92-7889-03	1	Spindle Wa-RH
31	94-1962-03	1	Front Axle Wa
32	88-5380	1	Tie Rod - Steering
33	32151-48	2	Ring-Retaining
34	88-4830	1	Link - Drag
35	88-5510	1	Rod-Parking Brake
36	88-5520-03	1	Bracket-Parking Brake
37	88-0890	1	Grip - Parking Brake
38	3-6498	4	Washer-Thrust

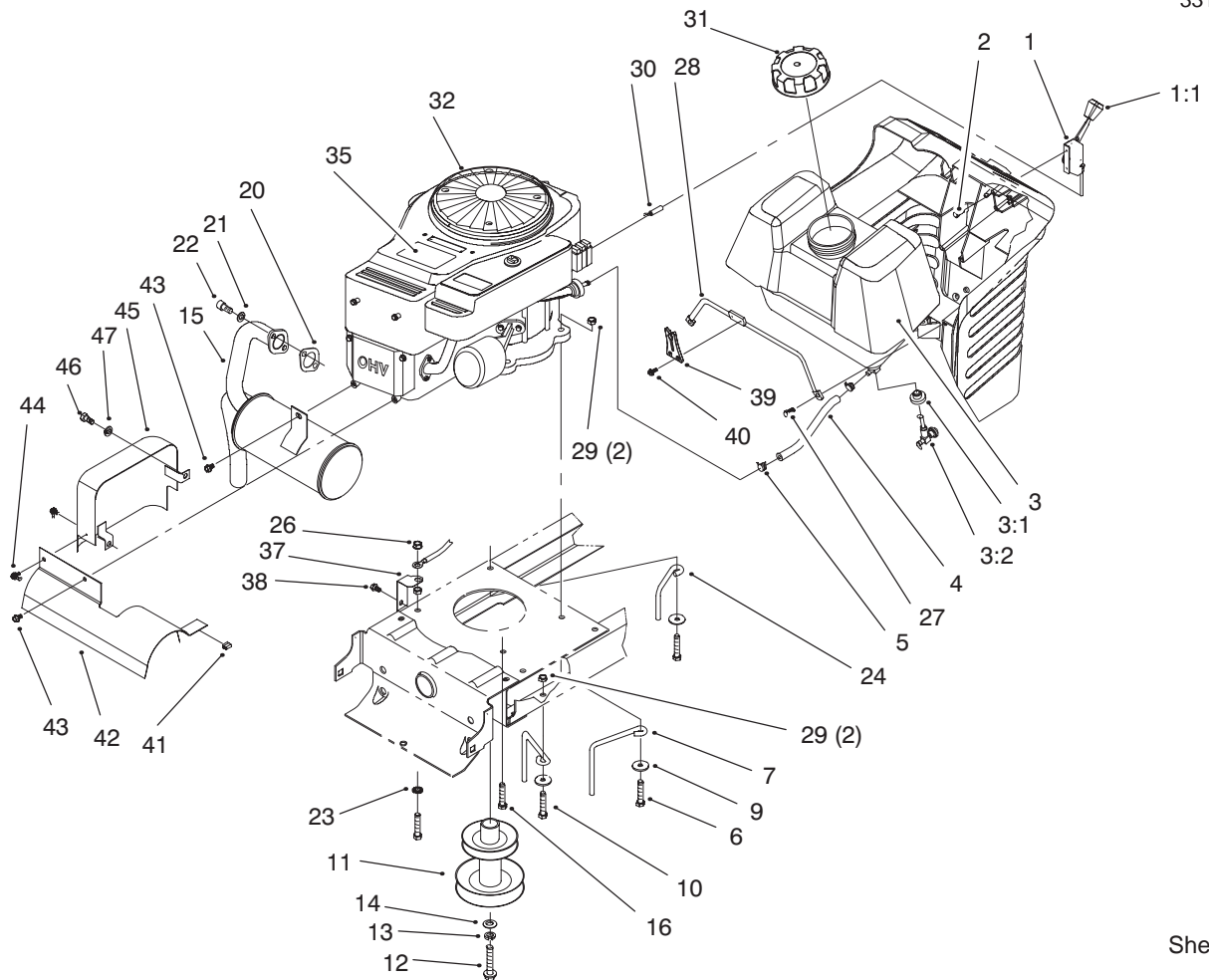

Sheet No.:8

Engine & Gas Tank Assembly

Ref. No.	Part No.	Qty.	Description
1	88-4340	1	Throttle Control ASM
1:1	66-0120	1	Knob
2	27-0220	2	Screw-Special HWH
3	88-3880	1	Gas Tank Assembly
3:1	104047	1	Bushing
3:2	104048	1	Assembly-Valve
4	47-2963	1	Fuel Line
5	2412-98	2	Clamp-Hose
6	322-9	3	Screw-HH
7	93-3854	3	Belt Guide - Engine
9	5-4460	4	Washer-Fender
10	322-5	2	Screw-HH
11	88-4850	1	Pulley - Engine (38")
12	26-0671	1	Bolt-Blade
13	3253-22	1	Washer-Lock
14	3256-25	1	Washer-Flt
15	94-1953	1	Muffler-Exhaust
16	9267154	1	Screw
20	88-4410	1	Gasket - Muffler
21	3253-4	2	Washer-Lock
22	3274-10	2	Screw-Sckt Hd
23	3255-8	1	Washer-Lock
24	93-3855	1	Belt Guide - R.h.
26	32149-1	2	Nut-Keps
27	27-0220	2	Screw-Special HWH
28	94-1952	1	Rod-Gas Tank

Ref. No.	Part No.	Qty.	Description
29	3296-29	4	Nut-Lock
30	88-4350	1	Cable ASM-Throttle
31	88-3980	1	Gas Cap ASM
32	95-1696	1	Engine-14.5hp B&s (Carb)
35	94-3525	1	Decal-Engine
37	93-3809	1	Bracket-Ground
38	9266714	1	Screw-HWHTF
39	94-1951	1	Latch-Hood
40	32144-112	2	Screw-Thd Form
41	93-3882	1	Clip-Tinnerman
42	93-3880-03	1	Shield - Muffler
43	9266714	2	Screw-HWHTF
44	32104-76	2	Screw-Self TAP
45	93-8450-03	1	Exhaust Shield Wa
46	322-3	1	Screw-HH
47	3253-4	1	Washer-Lock

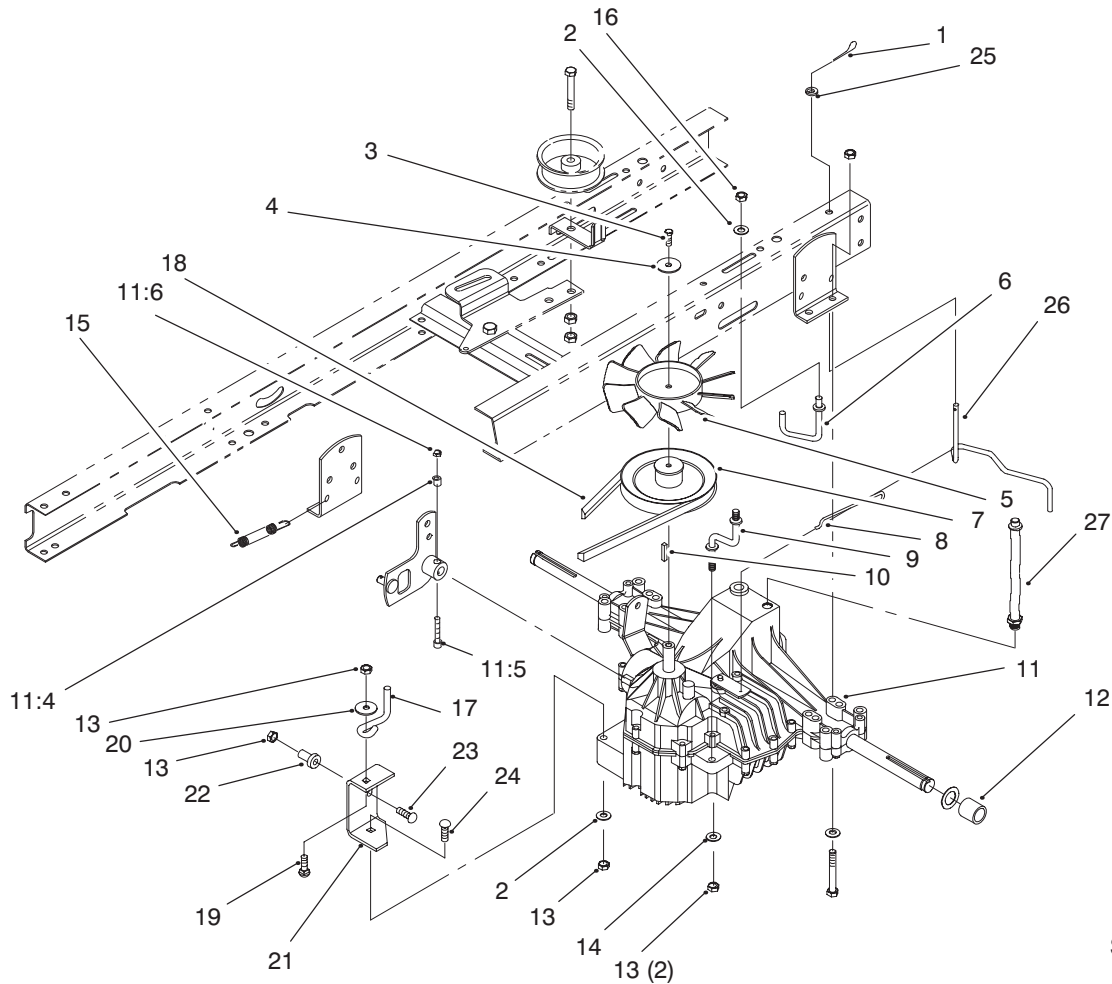

Sheet No.:12

Transaxle Assembly

Ref. No.	Part No.	Qty.	Description
1	3290-307	1	Pin-Cotter
2	3256-23	2	Washer-Flat
3	48-7620	1	Screw
4	3256-58	1	Washer-Fit
5	115271	1	Fan-Hydro
6	88-5960	1	Belt Guide - Trans. LH
7	88-6180	1	Pulley - Transmission
8	92-8856	1	Wire - Bypass
9	88-5620	1	Strap - Torque
10	80-6090	1	Key-Square
11	94-6775	1	Transaxle ASM-Hydro
11:4	86-4270	1	Spacer - Lock
11:5	3274-59	1	Screw - HSH
11:6	3296-12	1	Nut - Lock Thin
12	88-5360	2	Spacer - Pulley
13	3296-29	5	Nut-Lock
14	3256-23	2	Washer-Flat
15	26-6701	1	Spring - Extension
16	32149-1	1	Nut-Keps
17	88-5460	1	Belt Guide - Trans
18	88-6280	1	V-Belt
19	3230-2	1	Screw-CARR
20	5-4460	1	Washer-Fender
21	92-6013-03	1	Bracket - Speed Control

Ref. No.	Part No.	Qty.	Description
22	65-5080	1	Bushing - Flanged
23	3230-5	1	Bolt-Carriage
24	3230-7	1	Bolt-Carriage
25	3256-22	1	Washer-Flat
26	92-8857	1	Lever - Bypass
27	94-1945	1	ASM-Breather Hose

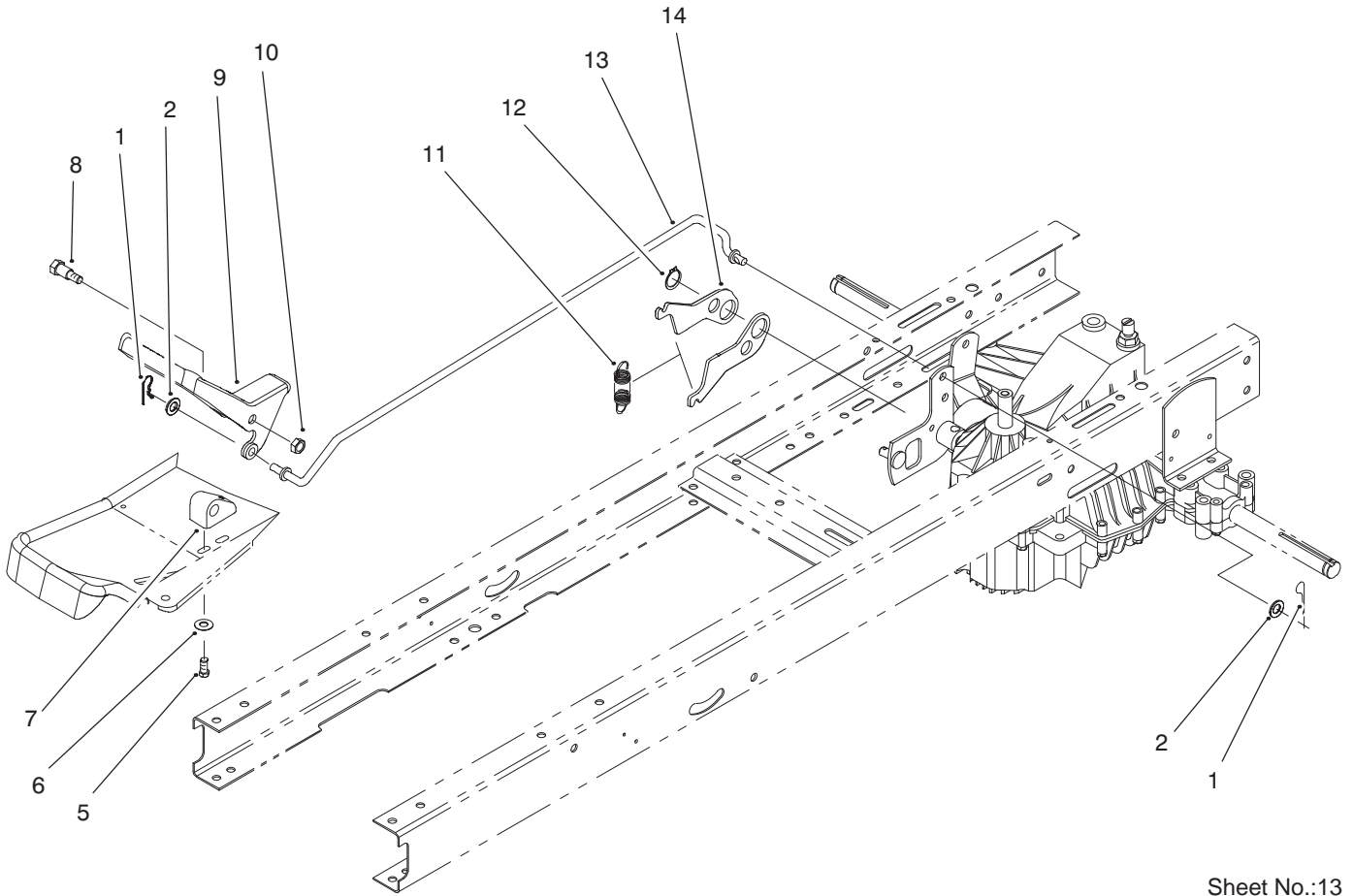

Sheet No.:13

Speed Control Assembly

Ref. No.	Part No.	Qty.	Description
1	3290-307	2	Pin-Cotter
2	3256-23	2	Washer-Flat
5	46-8090	2	Screw-Tapping
6	3256-22	2	Washer-Flat
7	88-4690	1	Block - Pivot
8	23-0310	1	Shoulder Bolt
9	93-3812	1	Pedal - Speed Control
10	3296-59	1	Nut-Lock
11	92-7305	1	Spring - Extension
12	32151-83	1	Ring-Retaining
13	92-9793	1	Rod-Speed Control
14	88-5610	2	Lever - Neutral Return

Ref. No.	Part No.	Qty.	Description

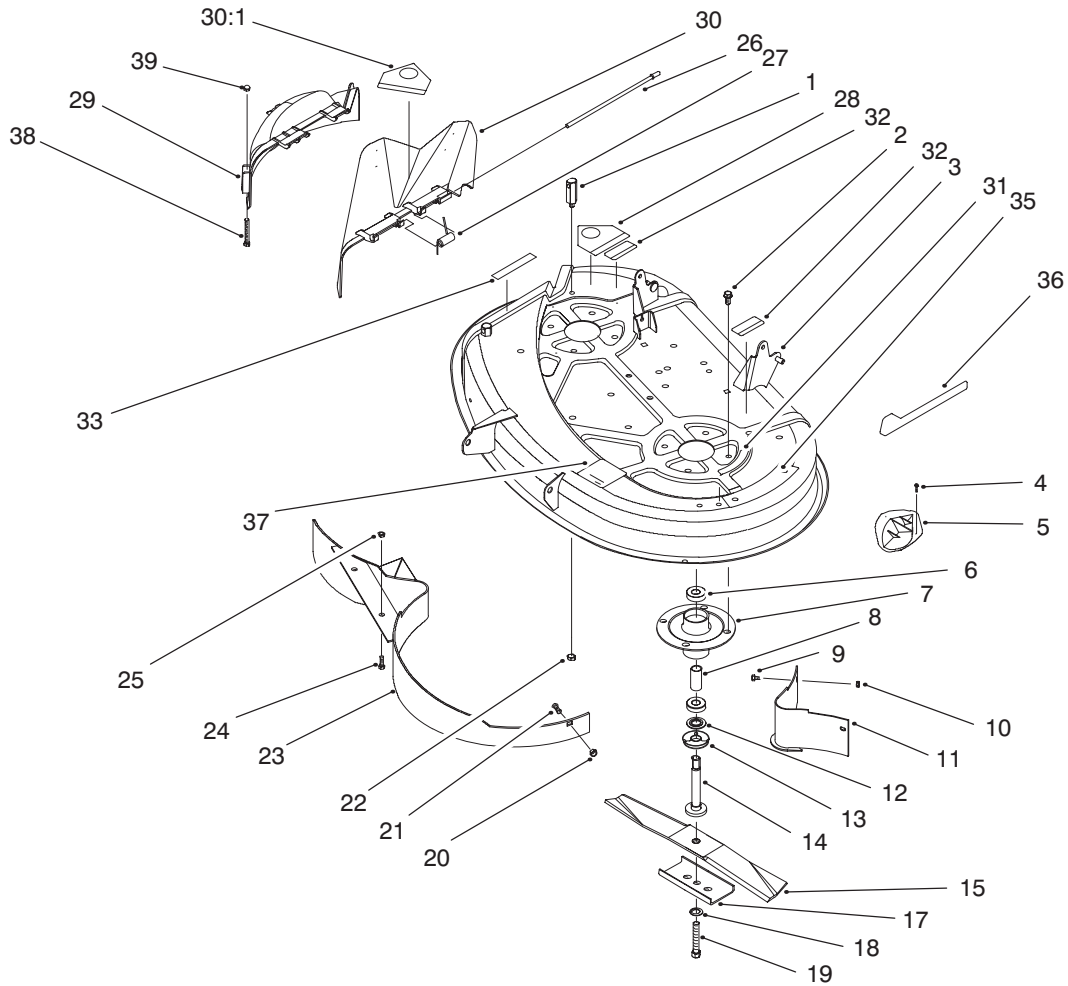

Sheet No.:16

Deck Assembly (38" Cutting Unit)

Ref. No.	Part No.	Qty.	Description
1	57-4360	1	Pivot Post – Rear
2	32144-41	8	Screw-HWHTF
3	94-1949-01	1	Deck Wa-38"
4	32144-111	8	Screw – PPH
5	76-2160	4	Plate-Kicker
6	38-7820	4	Bearing-Ball
7	88-4510	2	Spindle – Diecast Alum.
8	62-3661	2	Spacer – Bearing
9	321-4	2	Screw-HH
10	3296-42	2	Nut-Lock
11	79-1640-03	1	Wa-Baffle
12	80-4380	2	Spacer – Hardened
13	80-4360	2	Shield – Bearing
14	80-4341	2	Shaft – Spindle
15	79-3061	2	Blade-19.32 Recycler
17	80-0510-03	2	Stiffener-Blade
18	3290-465	2	Washer-Spring
19	26-0671	2	Bolt-Blade
20	3296-29	1	Nut-Lock
21	3230-1	1	Bolt-CARR
22	3296-39	1	Nut-Lock
23	79-1600-03	1	Wa-Baffle
24	323-5	2	Screw-HH
25	3296-39	2	Nut-Lock
26	57-4380	1	Rod- Hinge Deflector

Ref. No.	Part No.	Qty.	Description
27	57-6950	1	Spring-Torsion Deflector
28	93-1122	1	Decal-Danger
29	88-4430	1	Recycler Cover ASM
30	93-0317	1	ASM-Deflector
30:1	93-1122	1	Decal – Danger
31	68-3660	1	Decal – Shield Danger
32	55-4300	2	Decal-Warning
33	68-3650	1	Decal-Danger
35	79-3140	1	Decal-Danger
36	92-9520	1	Decal-Deck
37	93-6679	1	Decal – Belt Routing
38	321-15	2	Screw-HH
39	32111-7	2	Nut-Cap

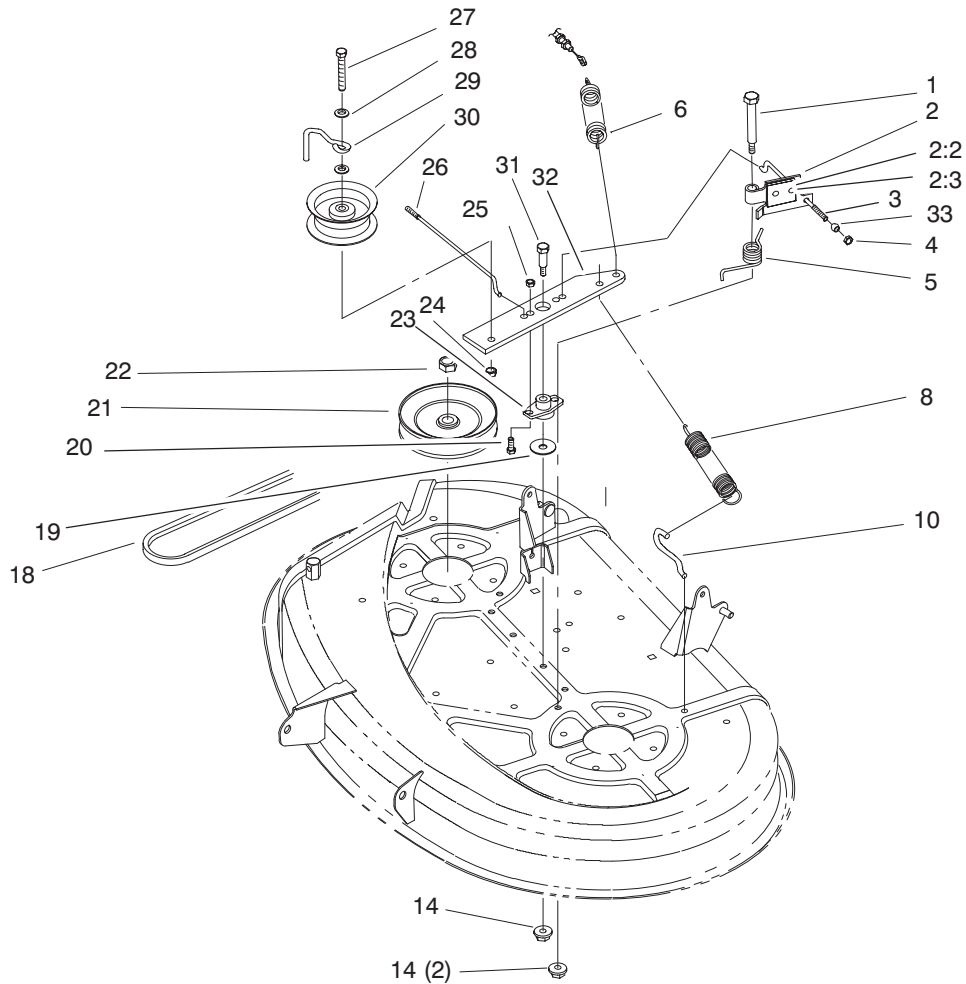

Sheet No.:17

Pulley & Belt Assembly (38" Cutting Unit)

Ref. No.	Part No.	Qty.	Description
1	88-4590	2	Bolt-Shoulder
2	88-6100	2	ASM. - Deck Brake
2:2	56-9830	2	Brake Pad
2:3	3290-282	2	Pop Rivet
3	88-5550	1	Rod -LH Deck Brake
4	3296-42	2	Nut-Lock
5	88-5910	2	Spring - Torsion
6	88-6130	1	Spring - Deck Engage
8	92-8934	1	Spring - Extension
10	88-5970	1	Hook - Return Spring
14	3296-58	3	Nut-Flange
18	88-6250	1	V-Belt
19	3256-68	1	Washer-Flt
20	322-5	2	Screw-HH
21	88-5330	2	Pulley - Deck
22	3219-6	2	Nut-Hex
23	88-4980	1	Bushing - Idler Arm
24	3296-39	1	Nut-Lock
25	3296-29	2	Nut-Lock
26	88-5540	1	Rod -RH Deck Brake
27	323-12	1	Screw
28	3256-24	2	Washer-Flat
29	88-5070	1	Belt Guide - Idler
30	88-5630	1	Pulley - Idler
31	7-0030	1	Shoulder Bolt

Ref. No.	Part No.	Qty.	Description
32	88-4870-03	1	Arm - Idler
33	67-0710	2	Ball - Swivel

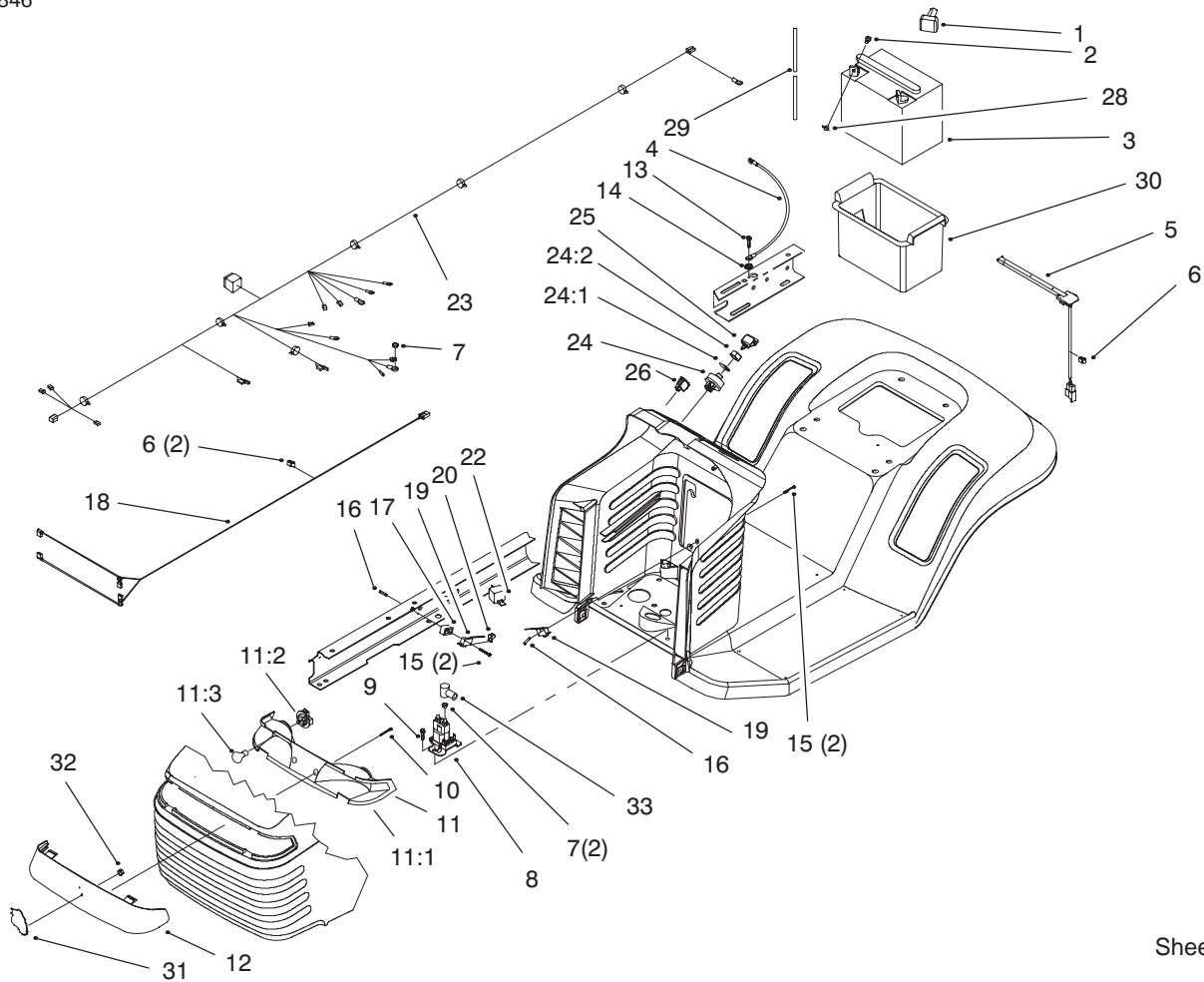

Sheet No.:20

Electrical Assembly

Ref. No.	Part No.	Qty.	Description
1	28-8080	1	Boot-Battery Terminal
2	321-4	2	Screw-HH
3	80-2600	1	Battery - 7 Plate
4	44-8110	1	Battery Cable -Neg
5	38-1420	1	Switch-Seat
6	702366	1	Clip-Wire Retainer
7	702366	2	Clip-Wire Retainer
8	32149-2	3	Nut-Hex Lock
9	92-9845	1	Solenoid
10	9266714	2	Screw-HWHTF
11	32144-32	2	Screw-Plastic
11:1	88-3970	1	Reflector-Lamp
11:2	93-8741	1	Reflector
11:3	111686	2	Socket Light
12	7228	2	Bulb
13	88-3960	1	Lense - Headlights
14	9266714	1	Screw-HWHTF
15	3255-7	1	Washer-Lock
16	93-0539	4	Screw-PPH
17	3290-354	2	Nut-Speed
18	88-4880	1	Spacer - Microswitch
19	88-4320	1	Harness-Wire
20	88-9932	2	Switch - Micro
22	93-3240	1	Seal-Plunger
23	116397	1	Relay
23	93-3810	1	Wire Harness

Ref. No.	Part No.	Qty.	Description
24	88-9830	1	Switch-Ignition
24:1	3254-5	1	Washer-Lock(F/W Switch)
24:2	218-461	1	Nut-HH (F/W Sw)
25	63-8360	1	Key-Ignition
26	92-8875	1	Switch-Rocker
28	32103-22	2	Nut-Wing
29	56-2540	1	Tube-Vent Use w/80-2600
30	88-4040	1	Battery Box
31	80-2240	1	Plate-Name Grille
32	3290-299	1	Nut - Tinnerman
33	94-5362	1	Boot-Terminal Insulator

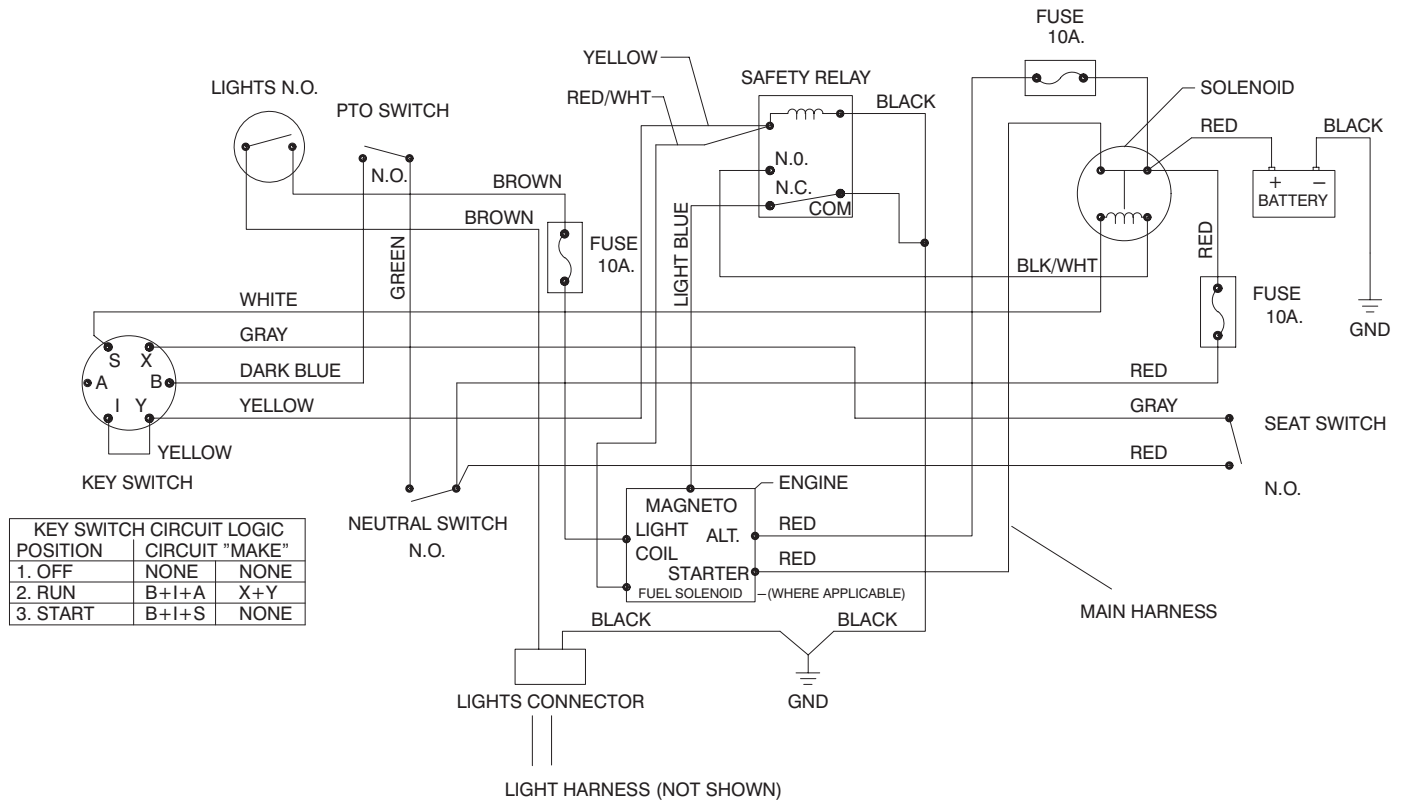

Sheet No.:21

Electrical Schematic

Ref. No.	Part No.	Qty.	Description
*	218-578	3	Fuse - 10 Amp

Ref. No.	Part No.	Qty.	Description

*Not Illustrated

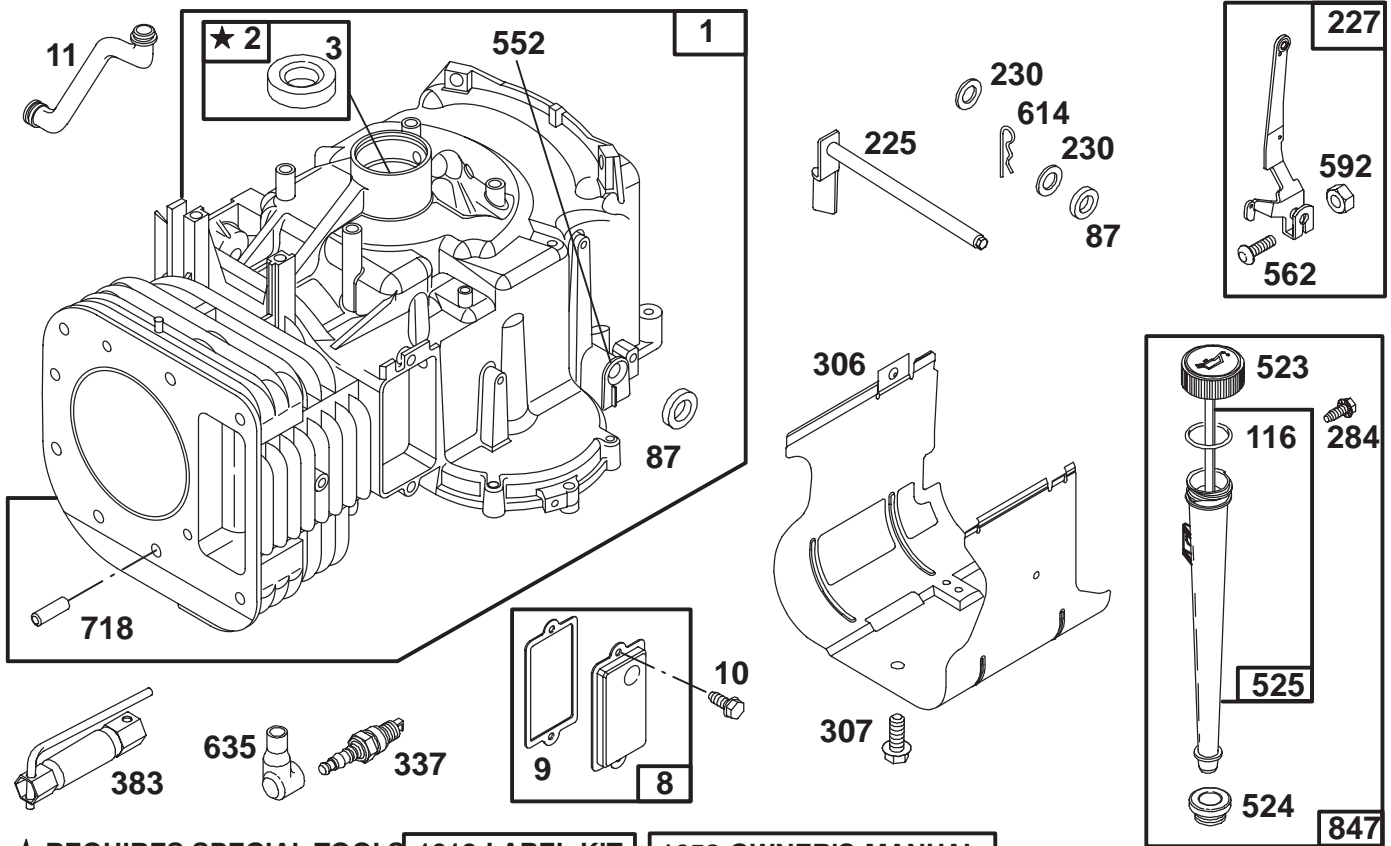

★ **REQUIRES SPECIAL TOOLS TO INSTALL. SEE REPAIR INSTRUCTION MANUAL.** **1019 LABEL KIT** **1058 OWNER'S MANUAL**
 Assemblies include all parts shown in frames.

ENGINE BRIGGS & STRATTON MODEL 28N707-0631-A1

Ref. No.	Part No.	Description	No. Used
1	496412	Cylinder Assembly	1
2	399265	Bearing-Cylinder	1
★3	391086	Seal-Oil	1
8	495735	Breather Assembly	1
★9	27803	Gasket-Valve Cover	1
10	94621	Screw-Sem	1
11	281246	Tube-Breather	1
★87	491323	Seal-Governor	1
★116	270920	Seal-Oil Fill Cap	1
227	493935	Lever Assy.-Governor	1
230	94927	Washer-Governor Lever	1
284	94903	Screw-Hex. Head	1
306	225020	Shield-Cylinder	1
307	94623	Screw-Self Tap	1
337	491055	Plug-Spark	1

Ref. No.	Part No.	Description	No. Used
383	89838	Wrench-Spark Plug	1
523	495230	Cap-Oil Fill	1
★524	281370	Seal-Fill Tube	1
525	496113	Tube-Oil Fill	1
552	231597	Bushing-Gov. Crank	1
562	92613	Bolt-Governor Lever	1
592	231082	Nut-Hex.	1
614	93306	Pin-Cotter	1
616	495157	Crank-Governor	1
635	280872	Elbow-Spark Plug	1
718	230192	Pin-Dowel	1
847	496415	Fill Group-Oil	1
1019	496758	Label Kit	1
1058	273132	Owner's Manual	1

★ Included in Gasket Set-Part No. 495993.
 Δ Included in Valve Overhaul Kit-Part No. 495992.

● Included in Carburetor Kit-Part No. 498116.
 ◆ Included in Carburetor Gasket Set-Part No. 494385.

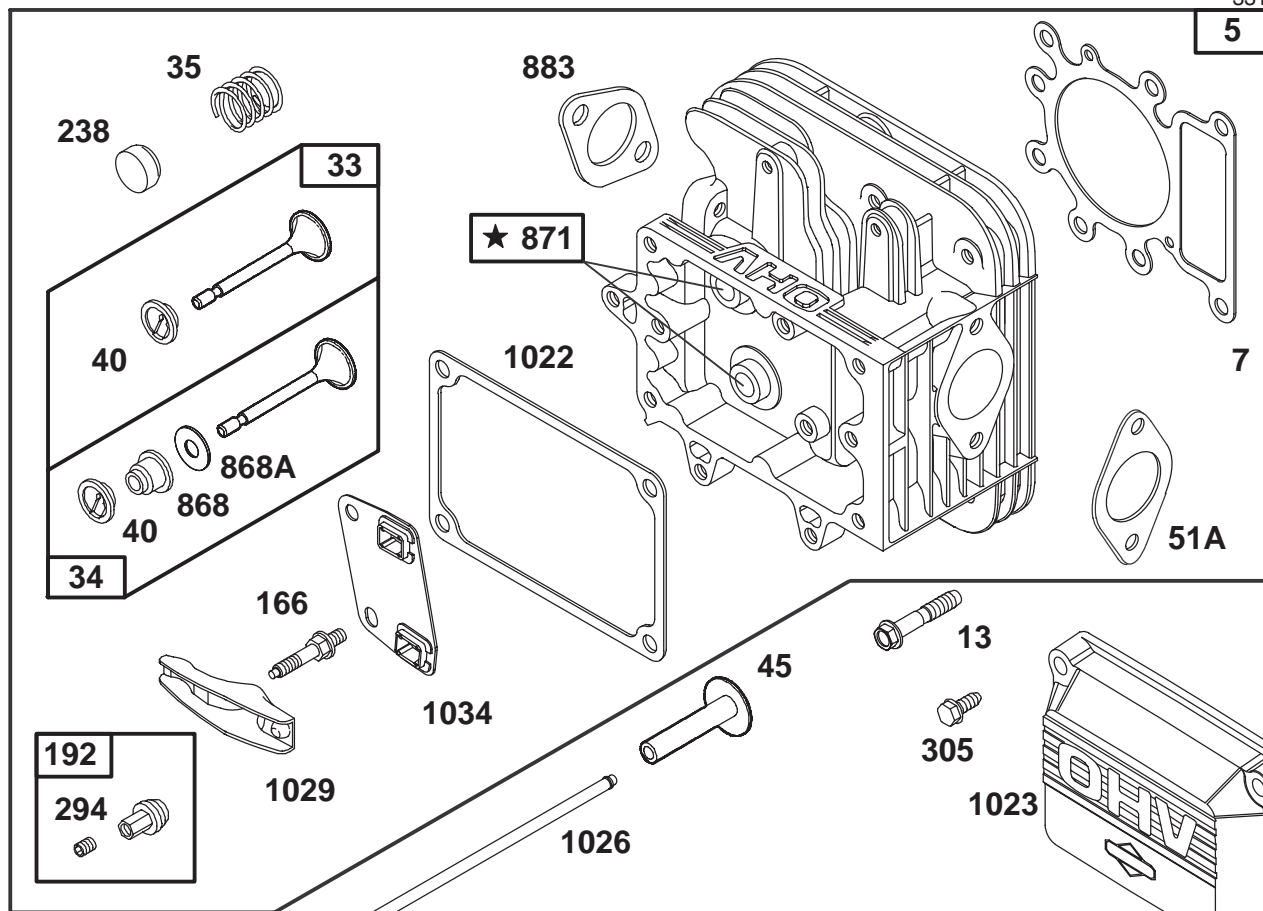

Assemblies include all parts shown in frames.

ENGINE BRIGGS & STRATTON MODEL 28N707-0631-A1

Ref. No.	Part No.	Description	No. Used
5	495858	Head—Cylinder	1
Δ*7	273280	Gasket—Cylinder Head	1
13	94728	Screw—Cylinder Head	1
33	495856	Valve—Exhaust	1
34	495857	Valve—Intake	1
35	262811	Spring—Valve	1
40	224641	Retainer—Valve	1
45	262411	Tappet—Valve	1
Δ*51A	272569	Gasket—Intake	1
166	94555	Stud—Rocker Arm	1
192	492160	Adjuster—Valve	1
238	262836	Cap—Valve	1
294	810068	Screw—Set	1

Ref. No.	Part No.	Description	No. Used
305	94786	Screw—Hex. Head	1
Δ*868	494435	Seal—Valve	1
Δ*868A	272610	Seal—Valve	1
871	262835	Bushing—Guide (Intake and Exhaust)	1
Δ*883	272293	Gasket—Exhaust	1
Δ*1022	272475	Gasket—Rocker Cover	1
1023	224552	Cover—Rocker	1
1026	494432	Rod—Push (Intake) Note: 495136 Rod—Push (Exhaust)	1
1029	224554	Arm—Rocker	1
1034	494432	Guide—Push Rod	1

★ Included in Gasket Set—Part No. 495993.

Δ Included in Valve Overhaul Kit—Part No. 495992.

● Included in Carburetor Kit—Part No. 498116.

◆ Included in Carburetor Gasket Set—Part No. 494385.

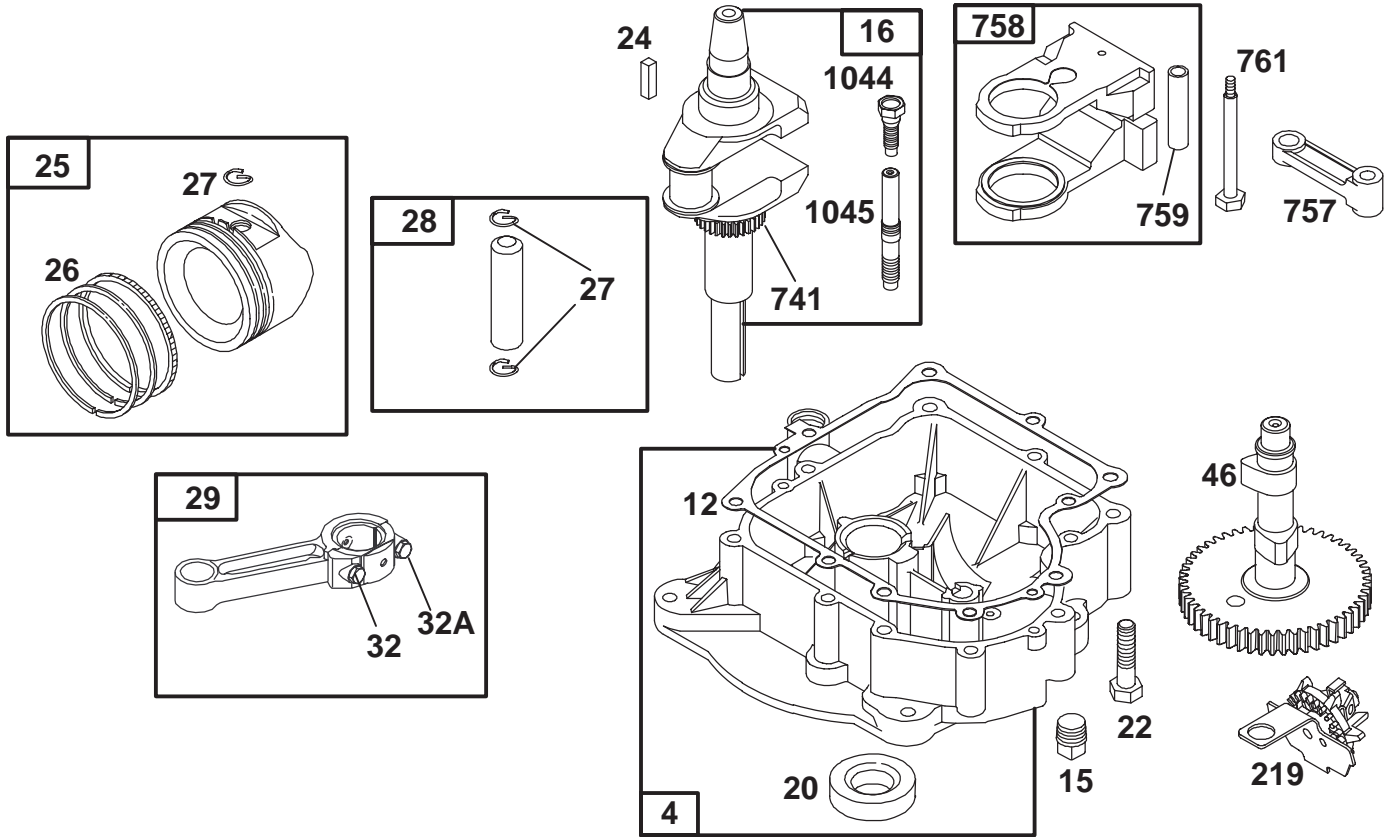

Assemblies include all parts shown in frames.

ENGINE BRIGGS & STRATTON MODEL 28N707-0631-A1

Ref. No.	Part No.	Description	No. Used
4	494238	Base-Engine	1
★12	271916	Gasket-Crankcase (.015" Thick)	1
★	271997	Gasket-Crankcase (.005" Thick)	1
★	271996	Gasket-Crankcase (.009" Thick)	1
15	94239	Plug-Oil Drain	1
16	495162	Crankshaft	1
		Note: For Timing Gear	1
		Key-Order 94196.	1
★20	291675	Seal-Oil	1
22	94624	Screw-Sem	1
24	222698	Key-Flywheel	1
25	494860	Piston Assembly (Standard)	1
	495977	Piston Assy. (.010" O.S.)	1
	495978	Piston Assy. (.020" O.S.)	1
	495979	Piston Assy. (.030" O.S.)	1
26	495854	Ring Set (Standard)	1
	495852	Ring Set (.010" O.S.)	1
	495851	Ring Set (.020" O.S.)	1
	495855	Ring Set (.030" O.S.)	1

Ref. No.	Part No.	Description	No. Used
27	263129	Lock-Piston Pin	1
28	498319	Pin-Piston (Standard)	1
	498320	Pin-Piston (.005" O.S.)	1
29	494504	Rod-Connecting	1
	495490	Rod-Conn. (.020" U.S.)	1
32	94695	Screw-Conn. Rod (1 57/64" Long)	1
32A	94648	Screw-Conn. Rod (1 5/8" Long)	1
46	496884	Gear-Cam	1
219	490815	Gear-Gov.	1
741	262932	Gear-Timing	1
757	213998	Link-Counterweight	1
758	399891	Counterweight Assy.	1
759	298909	Pin-Counterweight	1
761	94593	Screw-Counterweight	1
1044	94673	Screw-Shoulder	1
1045	231828	Extension-Crankshaft	1

★ Included in Gasket Set-Part No. 495993.

△ Included in Valve Overhaul Kit-Part No. 495992.

● Included in Carburetor Kit-Part No. 498116.

◆ Included in Carburetor Gasket Set-Part No. 494385.

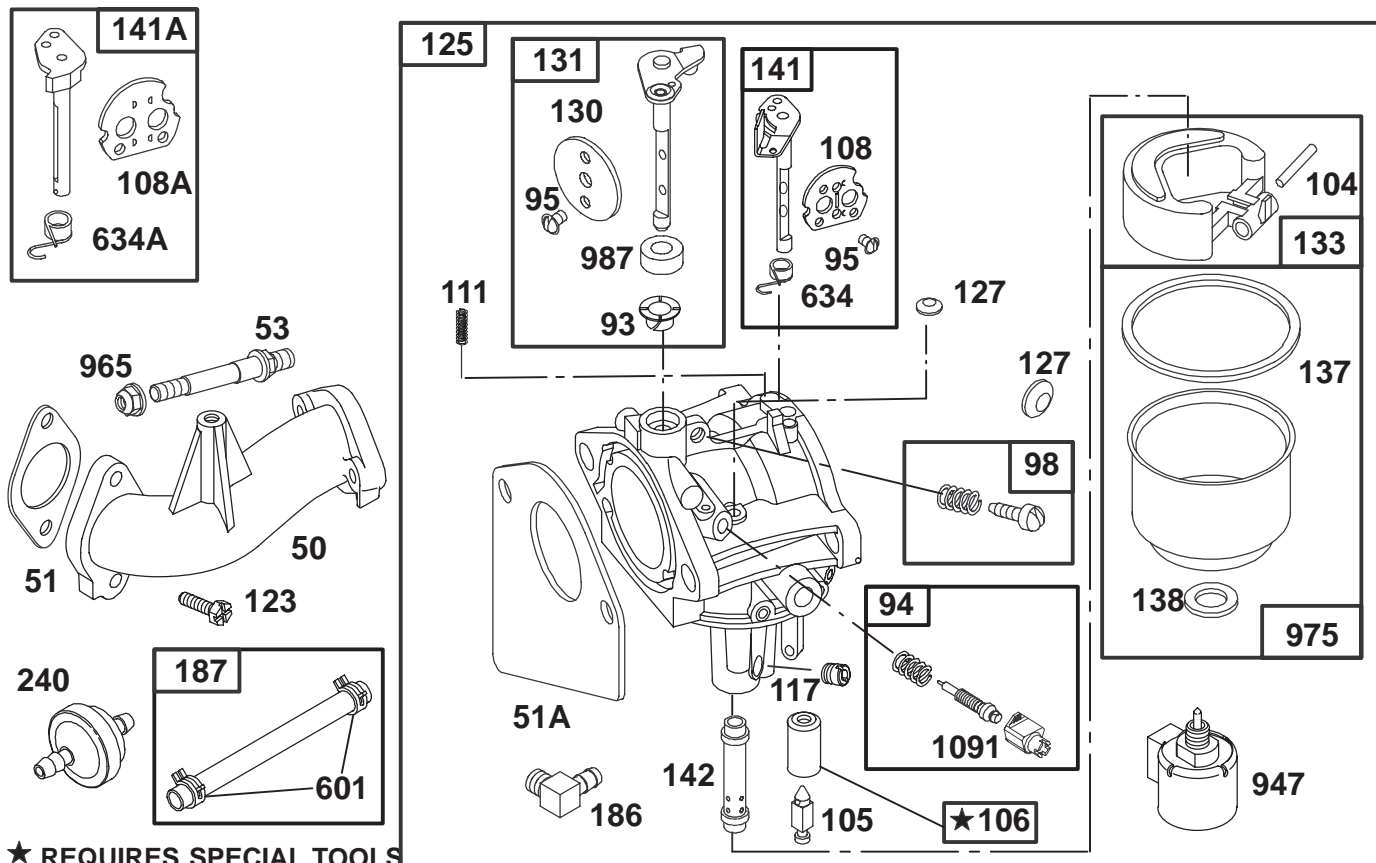

★ REQUIRES SPECIAL TOOLS TO INSTALL. SEE REPAIR INSTRUCTION MANUAL. Assemblies include all parts shown in frames.

ENGINE BRIGGS & STRATTON MODEL 28N707-0631-A1

Ref. No.	Part No.	Description	No. Used
50	214047	Manifold-Intake	1
Δ★51	272569	Gasket-Carburetor	1
◆◆51A	272465	Gasket-Carburetor	1
53	94637	Stud-Carb. Mtg.	1
●93	281346	Bushing-Throttle Shaft	1
●95	94098	Screw-Round Head	1
94	498030	Valve-Idle Adjust	1
98	495800	Screw-Idle Adjust	1
●104	231789	Pin-Float Hinge	1
●105	231855	Valve-Inlet Needle	1
●106	231854	Seat-Inlet	1
108	224558	Valve-Choke	1
108A	224540	Valve-Choke	1
111	262715	Spring-Friction	1
●117	232118	Jet-Main (Standard)	1
	232119	Jet-Main (High Altitude)	1
123	94913	Screw-Elbow Mtg.	1
125	499153	Carburetor	1
●127		Plug-Welch (Sold in Kit Only)	1

Ref. No.	Part No.	Description	No. Used
130	224539	Valve-Throttle	1
131	494379	Shaft-Throttle	1
133	494381	Float-Carburetor	1
◆◆137	281165	Gasket-Float Bowl	1
◆◆138	281164	Washer-Float Bowl	1
141	495097	Shaft-Choke	1
141A	495931	Shaft-Choke	1
●142	232117	Nozzle-Carburetor	1
186	493496	Elbow-Fuel Pipe	1
187	296004	Line-Fuel (Cut to Length)	1
240	394358	Filter-Fuel	1
601	93053	Clamp-Hose	1
●634	494453	Seal-Spring Assembly	1
●634A	494455	Seal-Spring Assembly	1
947	497672	Solenoid	1
965	94010	Nut-Hex.	1
975	495933	Bowl-Float	1
●987	281166	Seal-Throttle Shaft	1
1091	281364	Cap-Limiter	1

★ Included in Gasket Set-Part No. 495993.
 Δ Included in Valve Overhaul Kit-Part No. 495992.

● Included in Carburetor Kit-Part No. 499116.
 ◆ Included in Carburetor Gasket Set-Part No. 494385.

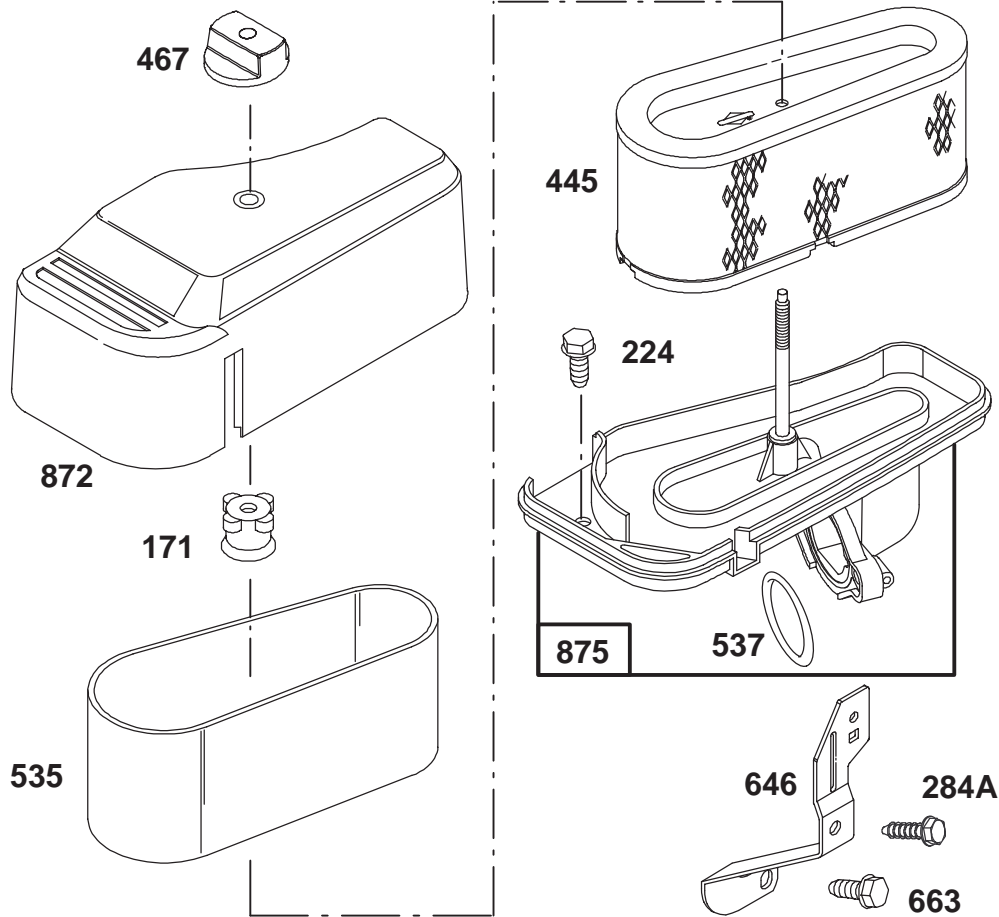

Assemblies include all parts shown in frames.

ENGINE BRIGGS & STRATTON MODEL 28N707-0631-A1

Ref. No.	Part No.	Description	No. Used
171	281051	Nut—Air Cleaner Mtg.	1
224	94729	Screw—Air Cleaner Sem	1
284A	94704	Screw—Air Cleaner	1
445	496894	Filter—Air	1
467	493903	Knob—Air Cleaner	1
535	272403	Filter—Air	1

Ref. No.	Part No.	Description	No. Used
★537	281106	Gasket—Air Cleaner	1
646	224546	Brace—Air Cleaner	1
663	94929	Screw—Hex. Hd.	1
872	281361	Cover—Air Cleaner	1
875	495862	Body—Air Cleaner	1

★ Included in Gasket Set—Part No. 495993.

△ Included in Valve Overhaul Kit—Part No. 495992.

● Included in Carburetor Kit—Part No. 498116.

◆ Included in Carburetor Gasket Set—Part No. 494385.

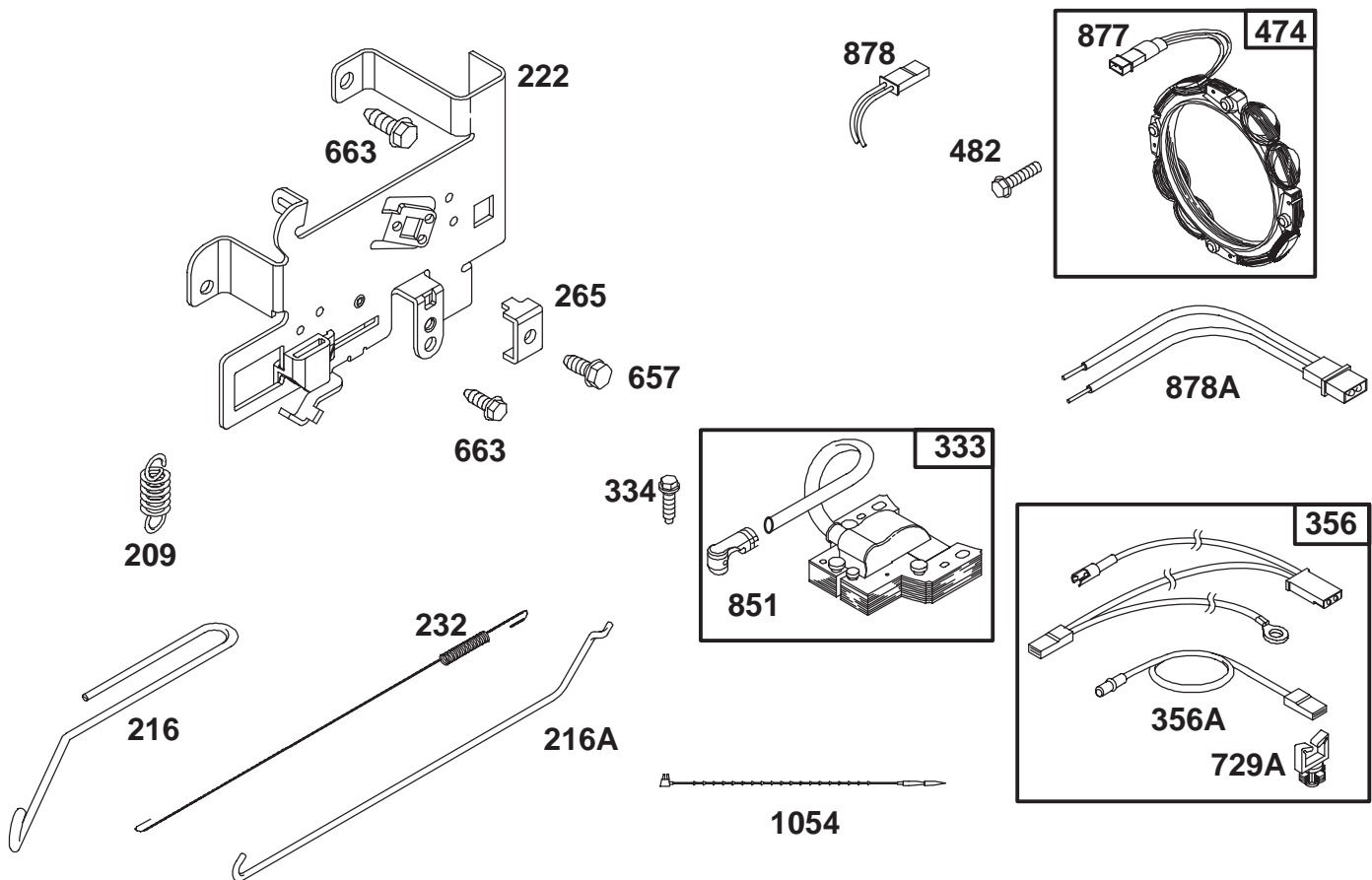

Assemblies include all parts shown in frames.

ENGINE BRIGGS & STRATTON MODEL 28N707-0631-A1

Ref. No.	Part No.	Description	No. Used
209	260695	Spring-Governor	1
216	262766	Link-Choke	1
216A	262767	Link-Governor	1
222	495611	Plate-Gov. Control	1
232	262785	Spring-Governor Link	1
265	221535	Clamp-Casing	1
333	495859	Armature-Magneto	1
334	94731	Screw-Sem	1
356	497708	Wire-Stop	1
356A	494705	Wire-Ground	1

Ref. No.	Part No.	Description	No. Used
474	393474	Alternator	1
482	93621	Screw-Sem	1
657	94906	Screw-Sem	1
663	94929	Screw-Hex. Hd.	1
729A	281390	Clip-Lead Wire	1
851	493880	Terminal-Ignition Cable	1
877	393456	Diode Assy.	1
878	393362	Harness-Alternator	1
878A	399916	Harness-Alternator	1
1054	270723	Tie-Cable	1

★ Included in Gasket Set-Part No. 495993.

△ Included in Valve Overhaul Kit-Part No. 495992.

● Included in Carburetor Kit-Part No. 499116.

◆ Included in Carburetor Gasket Set-Part No. 494385.

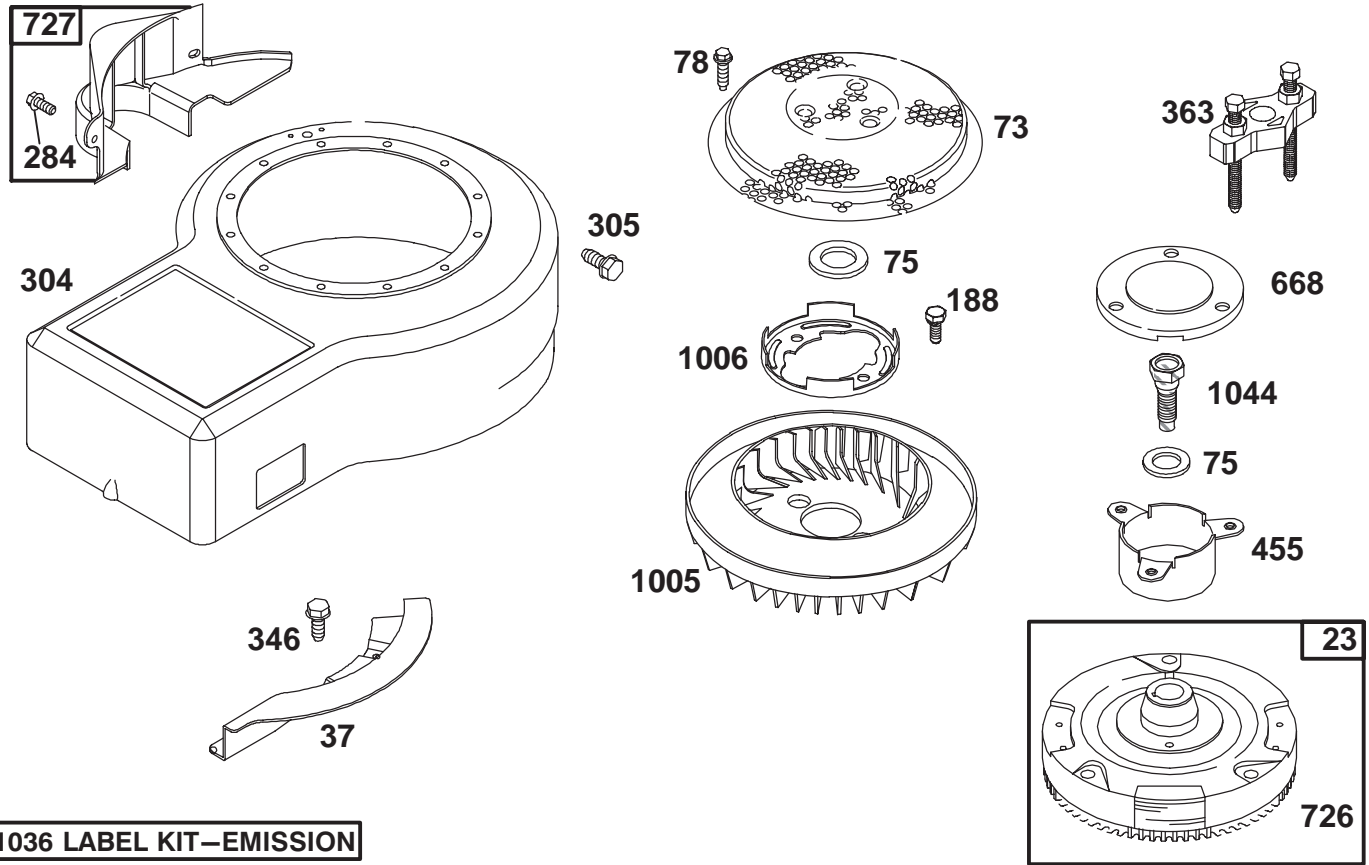

Assemblies include all parts shown in frames.

ENGINE BRIGGS & STRATTON MODEL 28N707-0631-A1

Ref. No.	Part No.	Description	No. Used
23	492326	Flywheel	1
37	224502	Guard-Flywheel	1
73	224948	Screen-Rotating	1
75	225136	Washer-Spring	1
78	94954	Screw-Sem	1
188	94627	Screw-Sem	1
284	94073	Screw-Hex. Head	1
304	496431	Housing-Blower	1
305	94786	Screw-Hex. Head	1
346	93705	Screw-Hex. Head	1

Ref. No.	Part No.	Description	No. Used
363	19203	Puller-Flywheel	1
455	222561	Cup-Flywheel	1
668	280848	Spacer	1
726	392134	Gear-Ring	1
		(Includes Mtg. Hardware)	1
727	490324	Guard-Flywheel	1
1005	281355	Fan-Flywheel	1
1006	224413	Retainer-Fan	1
1036	499363	Label Kit-Emission	1
1044	94673	Screw-Shoulder	1

★ Included in Gasket Set-Part No. 494241.

◆ Included in Carburetor Gasket Set-Part No. 494385.

● Included in Carburetor Kit-Part No. 496622.

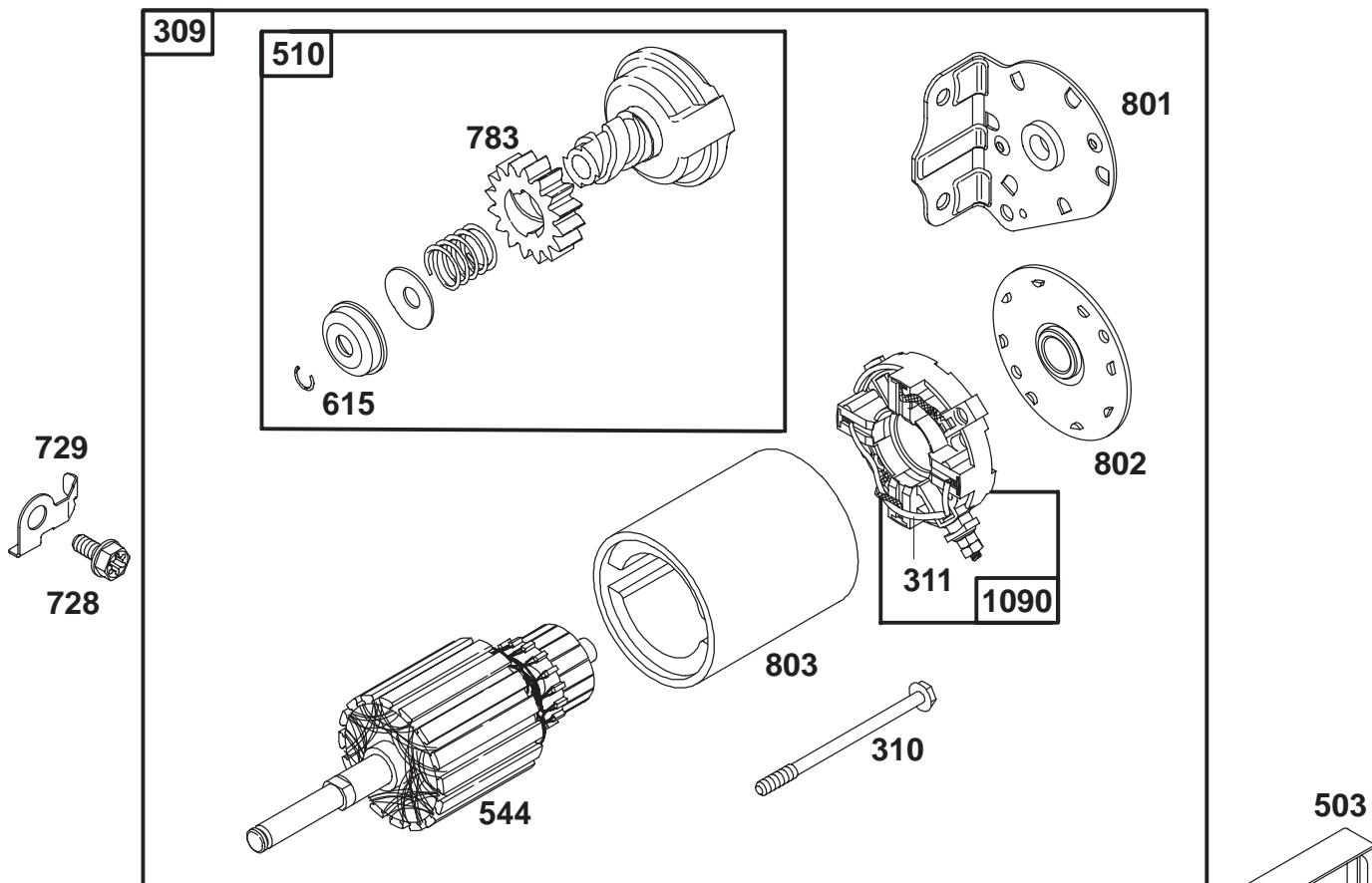

Assemblies include all parts shown in frames.

ENGINE BRIGGS & STRATTON MODEL 28N707-0631-A1

Ref. No.	Part No.	Description	No. Used
309	497595	Motor-Starter	1
310	94003	Bolt-Thru	1
311	497608	Brush Set	1
503	806000	Strap-Starter	1
510	497606	Drive-Starter	1
544	497603	Armature-Starter	1
615	263080	Retainer	1

Ref. No.	Part No.	Description	No. Used
728	94951	Screw-Torx®	1
729	225170	Clip-Wire	1
783	280104	Gear-Starter	1
801	394856	Cap-Drive	1
802	497607	Plate-Cover	1
803	497604	Housing-Starter	1
1090	497605	Cap-End	1

★ Included in Gasket Set-Part No. 495993.

△ Included in Valve Overhaul Kit-Part No. 495992.

● Included in Carburetor Kit-Part No. 498116.

◆ Included in Carburetor Gasket Set-Part No. 494385.

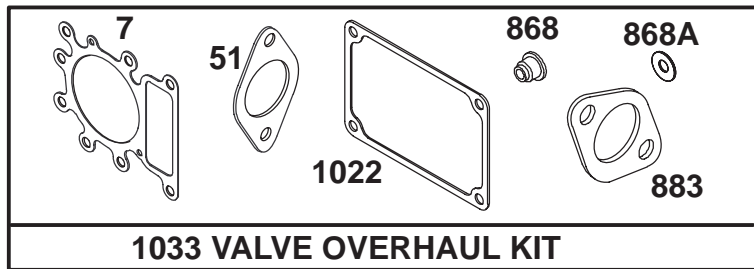
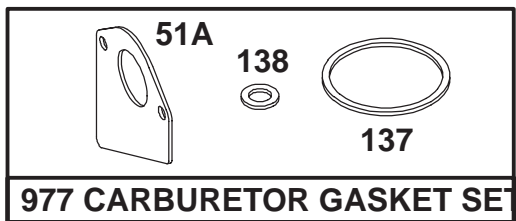
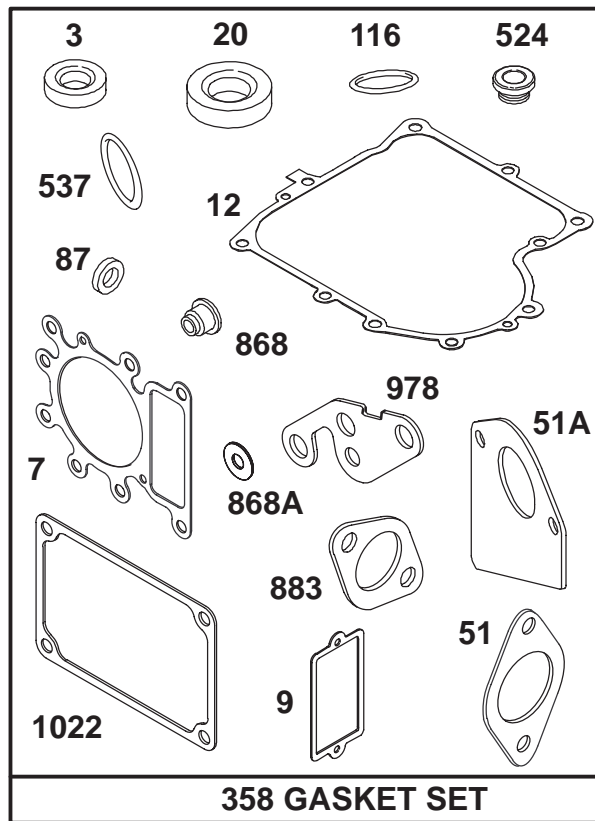
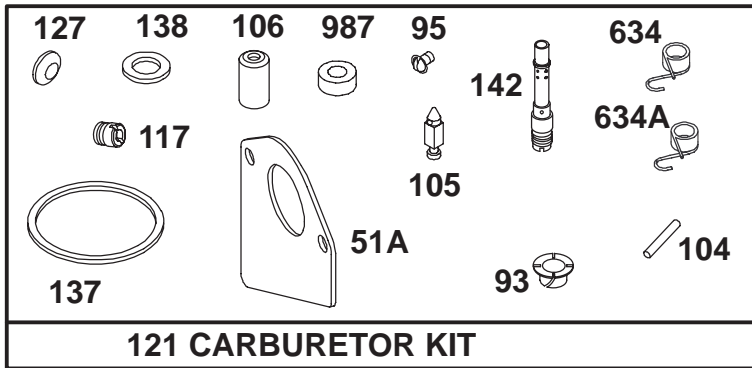

Assemblies include all parts shown in frames.

ENGINE BRIGGS & STRATTON MODEL 28N707-0631-A1

Ref. No.	Part No.	Description	No. Used
★3	391086	Seal—Oil	1
△★7	272614	Gasket—Cylinder Head	1
★9	27803	Gasket—Valve Cover	1
★12	271916	Gasket—Crankcase (.015" Thick)	1
★	271997	Gasket—Crankcase (.005" Thick)	1
★	271996	Gasket—Crankcase (.009" Thick)	1
★20	291675	Seal—Oil	1
△★51	272569	Gasket—Carburetor	1
◆★51A	272465	Gasket—Carburetor	1
★87	491323	Seal—Governor	1
●93	281346	Bushing—Throttle Shaft	1
●95	94098	Screw—Throttle	1
●104	231789	Pin—Float Hinge	1
●105	231855	Valve—Inlet Needle	1
●106	231854	Seat—Inlet	1
★116	270920	Seal—O Ring	1
●117	232118	Jet—Main	1

Ref. No.	Part No.	Description	No. Used
121	498116	Carburetor Kit	1
●127		Plug—Welch (Sold in Kit Only).	1
◆◆137	281165	Gasket—Float Bowl	1
◆◆138	281164	Washer—Float Bowl	1
●142	232117	Nozzle—Carburetor	1
358	495993	Gasket Set	1
★524	281370	Seal—Fill Tube	1
★537	281106	Gasket—Air Cleaner	1
●634	494453	Seal—Spring Assembly	1
●634A	494555	Seal—Spring Assembly	1
△★868	494435	Seal—Valve	1
△★868A	272610	Seal—Valve	1
★883	272293	Gasket—Exhaust	1
★977	494385	Carburetor Gasket Set	1
★978	272888	Gasket—Adapter	1
●987	281166	Seal—Throttle Shaft	1
△★1022	272475	Gasket—Rocker Cover	1
1033	495992	Kit—Valve Overhaul	1

★ Included in Gasket Set—Part No. 495993.

△ Included in Valve Overhaul Kit—Part No. 495992.

● Included in Carburetor Kit—Part No. 498116.

◆ Included in Carburetor Gasket Set—Part No. 494385.

Toro Part Number Index

Part No.	Page No.	Ref. No.	Qty.	Description
7228	15	11:3	2	Bulb
104047	6	3:1	1	Bushing
104048	6	3:2	1	Assembly—Valve
111419	4	12	1	Washer—Bearing
111686	15	11:2	2	Socket Light
115271	9	5	1	Fan—Hydro
116397	15	22	1	Relay
701178	1	1	2	Cap—Protector
702366	15	6	1	Clip—Wire Retainer
702366	15	6	2	Clip—Wire Retainer
9266714	2	36	2	Screw—HWHTF
9266714	6	38	1	Screw—HWHTF
9266714	6	43	2	Screw—HWHTF
9266714	15	9	2	Screw—HWHTF
9266714	15	13	1	Screw—HWHTF
9267154	6	16	1	Screw
3-6498	4	21	2	Washer—Thrust
3-6498	4	38	4	Washer—Thrust
3-6498	5	17	1	Washer—Thrust
3-6498	5	22	1	Washer—Thrust
3-6498	8	10	2	Washer—Thrust
3-7501	5	11	4	Washer—Curved
5-4460	3	4	1	Washer—Fender
5-4460	4	17	1	Washer—Fender
5-4460	6	9	4	Washer—Fender
5-4460	7	35	1	Washer—Fender
5-4460	9	20	1	Washer—Fender
7-0030	12	31	1	Shoulder Bolt
7-0030	14	11	2	Shoulder Bolt
7-0030	14	18	1	Shoulder Bolt
7-0036	8	11	2	Key—Square
23-0310	10	8	1	Shoulder Bolt
26-0671	6	12	1	Bolt—Blade
26-0671	11	19	2	Bolt—Blade
26-6701	9	15	1	Spring — Extension
27-0220	5	15	2	Screw—Special HWH
27-0220	6	2	2	Screw—Special HWH
27-0220	6	27	2	Screw—Special HWH
27-8890	7	1	1	Spring — Pedal Return
28-0540	2	6	2	Bolt—Shoulder
28-2480	4	28	2	Washer—Flat
28-2480	8	12	2	Washer—Flat
28-8080	15	1	1	Boot—Battery Terminal
37-8770	3	1	2	Bolt—Shldr
37-8770	3	2	2	Bolt—Shldr
37-8770	7	31	1	Bolt—Shldr
38-1420	15	5	1	Switch—Seat
38-7820	11	6	4	Bearing—Ball
44-8110	15	4	1	Battery Cable —Neg
46-6290	13	21	1	O—Ring
46-8090	2	13	4	Screw—Tapping
46-8090	2	17	3	Screw—Tapping
46-8090	10	5	2	Screw—Tapping
46-8091	2	3	2	Screw—Tapping
46-8091	2	10	1	Screw—Tapping
47-2963	6	4	1	Fuel Line
48-7620	9	3	1	Screw
52-2891	4	11	2	Bushing — Steering Links
55-4300	11	32	2	Decal—Warning
56-2540	15	29	1	Tube—Vent Use w/80-2600
56-9830	12	2:2	2	Brake Pad
57-4360	11	1	1	Pivot Post — Rear

*Not Illustrated

Toro Part Number Index (cont.)

Part No.	Page No.	Ref. No.	Qty.	Description
57-4380	11	26	1	Rod- Hinge Deflector
57-6950	11	27	1	Spring-Torsion Deflector
61-9780	4	26	2	Hubcap
61-9780	8	14	2	Hubcap
61-9980	13	8	2	Screw-Adjusting
62-3661	11	8	2	Spacer - Bearing
63-8360	15	25	1	Key-Ignition
65-2920	7	20	1	Pad-Pedal
65-5080	9	22	1	Bushing - Flanged
65-7210	14	23	1	Spacer
66-0120	6	1:1	1	Knob
67-0710	12	33	2	Ball - Swivel
68-3650	11	33	1	Decal-Danger
68-3660	11	31	1	Decal - Shield Danger
76-1340	1	32	1	Decal-USA
76-2160	11	5	4	Plate-Kicker
79-1600-03	11	23	1	Wa-Baffle
79-1640-03	11	11	1	Wa-Baffle
79-3061	11	15	2	Blade-19.32 Recycler
79-3140	11	35	1	Decal-Danger
80-0510-03	11	17	2	Stiffener-Blade
80-2240	15	31	1	Plate-Name Grille
80-2600	15	3	1	Battery - 7 Plate
80-4341	11	14	2	Shaft - Spindle
80-4360	11	13	2	Shield - Bearing
80-4380	11	12	2	Spacer - Hardened
80-6090	9	10	1	Key-Square
80-6990	13	9	4	Washer-Hardened
80-6990	14	8	4	Washer-Hardened
86-4270	9	11:4	1	Spacer - Lock
88-0890	4	37	1	Grip - Parking Brake
88-3840	1	28	1	Body - Rear
88-3850	5	1	1	Steering Wheel
88-3870	5	1:2	1	Cover-Steering Wheel
88-3880	6	3	1	Gas Tank Assembly
88-3940-03	1	5	1	Panel - Rear
88-3950	3	25	1	Seat
88-3960	15	12	1	Lense - Headlights
88-3970	15	11	1	Reflector-Lamp
88-3980	6	31	1	Gas Cap ASM
88-4020	13	7	1	Belt Guide - Deck
88-4030	13	2	1	Belt Guide - Deck
88-4040	15	30	1	Battery Box
88-4050	2	12	1	Duct - Hood Air
88-4070	4	29:2	2	Tire 15 X 6.00-6
88-4090	8	9:2	2	Tire - 18 X 9.50-8
88-4140	2	23	2	Nut - Wedge
88-4160	2	24	2	Clamp - Pivot Rod
88-4170	2	20	1	Rod - Pivot
88-4180	5	5	1	Button - Release
88-4190	5	4	1	Bushing - Sliding
88-4210	5	19	1	Bushing - Stationary
88-4230	14	13	2	Trunnion - HOC
88-4280	4	29	2	Front Wheel & Tire ASM
88-4300	8	9	2	Rear Wheel & Tire ASM
88-4320	15	18	1	Harness-Wire
88-4340	6	1	1	Throttle Control ASM
88-4350	6	30	1	Cable ASM-Throttle
88-4370	4	29:1	2	Rim ASM - 15" Front
88-4390	8	9:1	2	Rim ASM - 18" Rear
88-4400	4	29:4	2	Bearing - Wheel
88-4410	6	20	1	Gasket - Muffler

*Not Illustrated

Toro Part Number Index (cont.)

Part No.	Page No.	Ref. No.	Qty.	Description
88-4430	11	29	1	Recycler Cover ASM
88-4510	11	7	2	Spindle – Diecast Alum.
88-4590	12	1	2	Bolt-Shoulder
88-4620-03	1	11	1	Bracket – Idler Pivot
88-4630-03	1	24	1	Plate – Engine Mounting
88-4670	4	9	1	Bushing – Eccentric
88-4690	10	7	1	Block – Pivot
88-4730	14	16	2	Clamp – HOC Pivot
88-4810	7	13	1	Clamp – Shift Pivot
88-4820-03	3	11	2	Bracket – Seat Hinge
88-4830	4	34	1	Link – Drag
88-4850	6	11	1	Pulley – Engine (38")
88-4870-03	12	32	1	Arm – Idler
88-4880	15	17	1	Spacer – Microswitch
88-4890	5	10	1	Spring – Leaf
88-4910-03	3	3	1	Support – Seat
88-4980	12	23	1	Bushing – Idler Arm
88-4990	3	23	1	Tray – Fender
88-5000-03	7	21	1	Pedal – Clutch/Brake
88-5010	4	7	1	Spacer – Steering Rack
88-5030-03	3	9	1	Gate – HOC
88-5070	12	29	1	Belt Guide – Idler
88-5110-03	14	22	1	Pivot W.a. (H.o.c.)
88-5120-03	1	21	1	Support – Front Axle
88-5130-03	4	5	1	Bracket – Steering Rack
88-5150	5	16	1	Bushing – Flange
88-5170	3	7	1	Cover – HOC
88-5180-01	5	8	1	Bracket – Backup
88-5190-03	2	25	1	Lever W.a. – Deck Engage
88-5200	4	10	1	Steering Rack W.a.
88-5230	3	17	1	Foot Mat – RH
88-5240	3	16	1	Foot Mat
88-5260-03	1	10	2	Bracket-Transaxle Mounti
88-5270	7	29	1	Rod – Clutch/Brake
88-5330	12	21	2	Pulley – Deck
88-5360	9	12	2	Spacer – Pulley
88-5380	4	32	1	Tie Rod – Steering
88-5450	14	12	2	Rod – Hanger
88-5460	9	17	1	Belt Guide – Trans
88-5470	4	23	2	Spacer – Front Axle
88-5500	7	15	1	Rod – Pedal Pivot
88-5510	4	35	1	Rod-Parking Brake
88-5520-03	4	36	1	Bracket-Parking Brake
88-5540	12	26	1	Rod –RH Deck Brake
88-5560	7	32	1	Belt Guide – Idler
88-5570-03	14	6	2	Link-Adjusting HOC
88-5610	10	14	2	Lever – Neutral Return
88-5620	9	9	1	Strap – Torque
88-5630	12	30	1	Pulley – Idler
88-5680	7	33	1	Idler Pulley
88-5900	14	3	1	Link – HOC
88-5910	12	5	2	Spring – Torsion
88-5960	9	6	1	Belt Guide – Trans. LH
88-5970	12	10	1	Hook – Return Spring
88-6040-03	2	18	1	Bracket – Hinge
88-6050-03	2	7	1	Bracket – Hinge
88-6070	7	30	1	Arm –Idler
88-6090	5	20	1	Coupling – Steering
88-6100	12	2	2	ASM. – Deck Brake
88-6130	12	6	1	Spring – Deck Engage
88-6140	7	2	1	Spring – Brake
88-6180	9	7	1	Pulley – Transmission

*Not Illustrated

Toro Part Number Index (cont.)

Part No.	Page No.	Ref. No.	Qty.	Description
88-6220	1	4	2	Spring - Compression
88-6250	12	18	1	V-Belt
88-6280	9	18	1	V-Belt
88-6300	5	13	1	Shaft - Steering
88-6330	7	7	1	Spring - Extension
88-6370	5	14	1	Shaft W.a. - Steering
88-6460	14	17	1	Spring - Extension
88-9830	15	24	1	Switch-Ignition
88-9932	15	19	2	Switch - Micro
92-2460	2	30	1	Decal - Ignition/Lights
92-2461	2	31	1	Decal - Throttle
92-2462	2	32	1	Decal - Deck Engage
92-2467	2	34	1	Decal - Hood Right
92-2468	2	33	1	Decal - Hood Left
92-5748	2	14:1	1	Decal - Air Duct
92-5782	2	15	1	Patch - Heat Tape
92-6013-03	9	21	1	Bracket - Speed Control
92-7305	10	11	1	Spring - Extension
92-7889-03	4	30	1	Spindle Wa-RH
92-7890-03	4	18	1	Spindle Wa-LH
92-8650	2	14	1	Hood-Toro
92-8856	9	8	1	Wire - Bypass
92-8857	9	26	1	Lever - Bypass
92-8875	15	26	1	Switch-Rocker
92-8934	12	8	1	Spring - Extension
92-9520	11	36	1	Decal-Deck
92-9674	3	5	1	Knob-Studded
92-9793	10	13	1	Rod-Speed Control
92-9845	15	8	1	Solenoid
93-0303	2	1	1	Tower-Steering Toro
93-0317	11	30	1	ASM-Deflector
93-0539	15	15	4	Screw-PPH
93-1122	11	30:1	1	Decal - Danger
93-1122	11	28	1	Decal-Danger
93-3240	15	20	1	Seal-Plunger
93-3809	6	37	1	Bracket-Ground
93-3810	15	23	1	Wire Harness
93-3812	10	9	1	Pedal - Speed Control
93-3822-03	14	1	1	Lever-HOC
93-3849	2	37	1	Brkt-Cable
93-3854	6	7	3	Belt Guide - Engine
93-3855	6	24	1	Belt Guide - R.h.
93-3864	2	16	1	Shield - Heat
93-3880-03	6	42	1	Shield - Muffler
93-3881-03	13	4	1	Pan - Front Deck Suspens
93-3882	6	41	1	Clip-Tinnerman
93-6678	1	31	1	Decal - Dump Valve
93-6679	11	37	1	Decal - Belt Routing
93-8450-03	6	45	1	Exhaust Shield Wa
93-8741	15	11:1	1	Reflector
93-9847	13	12	2	Spacer
94-1238	1	33	1	Decal-Instruction
94-1945	9	27	1	ASM-Breather Hose
94-1949-01	11	3	1	Deck Wa-38"
94-1951	6	39	1	Latch-Hood
94-1952	6	28	1	Rod-Gas Tank
94-1953	6	15	1	Muffler-Exhaust
94-1962-03	4	31	1	Front Axle Wa
94-1970-03	13	14	1	Bracket-Deck Susp
94-1971-03	13	6	1	Bracket-Deck Susp
94-1980	2	39	2	Foam-Hood
94-1984	2	11	1	Pin-Latch

*Not Illustrated

Toro Part Number Index (cont.)

Part No.	Page No.	Ref. No.	Qty.	Description
94-1998-03	1	25	1	Frame Rail-RH
94-1999-03	1	13	1	Frame Rail-LH
94-3525	6	35	1	Decal-Engine
94-3527	2	29	2	Decal-Tower
94-3529	1	35	1	Decal-Rear Body
94-4293	2	35	1	Cable ASM-Deck Engage
94-5362	15	33	1	Boot-Terminal Insulator
94-5565	2	2	1	Knob - Control
94-5565	14	24	1	Knob - Control
94-5823	13	5	2	Bolt-Shoulder
94-6775	9	11	1	Transaxle ASM-Hydro
95-1696	6	32	1	Engine-14.5hp B&s (Carb)
95-2747	13	20	1	Fitting-Washout
95-3270	13	23	1	Connector - Hose
218-461	15	24:2	1	Nut-HH (F/W Sw)
232-27	4	29:3	2	Valve Stem & Cap Assembly
232-27	8	9:3	2	Valve Stem & Cap Assembly
232-39	4	29:6	2	Tube - Inner 15 X 6-6
232-41	8	9:4	2	Tube - Inner
2412-98	6	5	2	Clamp-Hose
302-5	4	29:5	2	Fitting - Grease
302-26	4	8	1	Fitting-Grease
321-2	2	5	4	Screw-HH
321-4	5	7	2	Screw-HH
321-4	11	9	2	Screw-HH
321-4	15	2	2	Screw-HH
321-9	5	21	2	Screw-HH
321-15	11	38	2	Screw-HH
322-3	1	7	4	Screw-HH
322-3	1	9	4	Screw-HH
322-3	1	20	6	Screw-HH
322-3	1	23	2	Screw-HH
322-3	1	26	4	Screw-HH
322-3	1	27	2	Screw-HH
322-3	2	28	2	Screw-HH
322-3	3	10	4	Screw-HH
322-3	6	46	1	Screw-HH
322-3	7	14	2	Screw-HH
322-3	14	19	4	Screw-HH
322-5	1	2	2	Screw-HH
322-5	6	10	2	Screw-HH
322-5	12	20	2	Screw-HH
322-9	6	6	3	Screw-HH
322-9	14	2	1	Screw-HH
322-12	8	15	4	Screw HH
322-12	13	16	2	Screw HH
323-5	11	24	2	Screw-HH
323-9	13	13	2	Screw-HH
323-11	7	34	1	Screw
323-12	12	27	1	Screw
323-13	4	2	2	Screw-HH
3219-6	12	22	2	Nut-Hex
3229-1	13	22	2	Bolt-CARR
3230-1	4	6	4	Bolt-CARR
3230-1	11	21	1	Bolt-CARR
3230-2	9	19	1	Screw-CARR
3230-3	4	4	1	Screw-CARR
3230-3	7	22	1	Screw-CARR
3230-5	9	23	1	Bolt-Carriage
3230-7	9	24	1	Bolt-Carriage
3231-4	4	3	1	Bolt-CARR
3253-4	6	21	2	Washer-Lock

*Not Illustrated

Toro Part Number Index (cont.)

Part No.	Page No.	Ref. No.	Qty.	Description
3253-4	6	47	1	Washer-Lock
3253-22	6	13	1	Washer-Lock
3254-5	15	24:1	1	Washer-Lock(F/W Switch)
3255-7	15	14	1	Washer-Lock
3255-8	6	23	1	Washer-Lock
3256-1	13	19	2	Washer-Flat
3256-22	5	6	2	Washer-Flat
3256-22	9	25	1	Washer-Flat
3256-22	10	6	2	Washer-Flat
3256-22	13	10	2	Washer-Flat
3256-23	1	3	2	Washer-Flat
3256-23	1	22	2	Washer-Flat
3256-23	2	27	2	Washer-Flat
3256-23	7	23	1	Washer-Flat
3256-23	8	16	4	Washer-Flat
3256-23	9	2	2	Washer-Flat
3256-23	9	14	2	Washer-Flat
3256-23	10	2	2	Washer-Flat
3256-24	2	21	2	Washer-Flat
3256-24	4	20	2	Washer-Flat
3256-24	4	24	2	Washer-Flat
3256-24	12	28	2	Washer-Flat
3256-24	14	5	2	Washer-Flat
3256-24	14	10	2	Washer-Flat
3256-25	4	13	4	Washer-Flt
3256-25	6	14	1	Washer-Flt
3256-26	7	18	1	Washer-Flt
3256-58	9	4	1	Washer-Flt
3256-68	12	19	1	Washer-Flt
3272-10	4	14	2	Pin-Cotter
3272-10	4	19	2	Pin-Cotter
3272-10	7	24	1	Pin-Cotter
3272-12	4	27	2	Pin-Cotter
3274-10	6	22	2	Screw-Sckt Hd
3274-59	9	11:5	1	Screw - HSH
3290-282	12	2:3	2	Pop Rivet
3290-282	3	8	2	Pop Rivet
3290-299	15	32	1	Nut - Tinnerman
3290-307	2	19	2	Pin-Cotter
3290-307	9	1	1	Pin-Cotter
3290-307	10	1	2	Pin-Cotter
3290-307	14	4	1	Pin-Cotter
3290-307	14	7	4	Pin-Cotter
3290-307	14	9	2	Pin-Cotter
3290-354	15	16	2	Nut-Speed
3290-465	11	18	2	Washer-Spring
3290-479	3	6	4	Fastener-Panel
3290-479	3	15	12	Fastener-Panel
3290-496	2	8	2	Nut - Retained
3296-12	9	11:6	1	Nut - Lock Thin
3296-16	13	18	2	Nut-Lock
3296-23	13	17	2	Nut-Lock
3296-29	1	6	2	Nut-Lock
3296-29	1	8	4	Nut-Lock
3296-29	1	12	4	Nut-Lock
3296-29	1	14	2	Nut-Lock
3296-29	1	15	6	Nut-Lock
3296-29	1	16	2	Nut-Lock
3296-29	1	29	4	Nut-Lock
3296-29	2	26	2	Nut-Lock
3296-29	3	12	6	Nut-Lock
3296-29	4	1	4	Nut-Lock

*Not Illustrated

Toro Part Number Index (cont.)

Part No.	Page No.	Ref. No.	Qty.	Description
3296-29	4	16	1	Nut-Lock
3296-29	6	29	4	Nut-Lock
3296-29	7	19	1	Nut-Lock
3296-29	7	26	2	Nut-Lock
3296-29	7	27	1	Nut-Lock
3296-29	8	1	4	Nut-Lock
3296-29	9	13	5	Nut-Lock
3296-29	11	20	1	Nut-Lock
3296-29	12	25	2	Nut-Lock
3296-29	13	15	2	Nut-Lock
3296-29	14	14	4	Nut-Lock
3296-29	14	15	2	Nut-Lock
3296-29	14	20	1	Nut-Lock
3296-29	14	21	1	Nut-Lock
3296-39	4	15	1	Nut-Lock
3296-39	4	25	2	Nut-Lock
3296-39	11	22	1	Nut-Lock
3296-39	11	25	2	Nut-Lock
3296-39	12	24	1	Nut-Lock
3296-39	13	3	2	Nut-Lock
3296-42	2	4	4	Nut-Lock
3296-42	5	9	2	Nut-Lock
3296-42	5	12	2	Nut-Lock
3296-42	11	10	2	Nut-Lock
3296-42	12	4	2	Nut-Lock
3296-42	13	11	2	Nut-Lock
3296-58	12	14	3	Nut-Flange
3296-59	7	28	2	Nut-Lock
3296-59	10	10	1	Nut-Lock
32103-22	15	28	2	Nut-Wing
32104-76	6	44	2	Screw-Self TAP
32104-76	13	1	5	Screw-Self TAP
32111-7	11	39	2	Nut-Cap
32121-111	5	2	1	Pin-Spiral
32128-43	2	22	2	Nut-Flange
32144-32	15	10	2	Screw-Plastic
32144-41	11	2	8	Screw-HWHTF
32144-111	11	4	8	Screw - PPH
32144-112	6	40	2	Screw-Thd Form
32149-1	6	26	2	Nut-Keps
32149-1	9	16	1	Nut-Keps
32149-2	15	7	3	Nut-Hex Lock
32151-48	4	33	2	Ring-Retaining
32151-48	5	18	1	Ring-Retaining
32151-48	8	13	2	Ring-Retaining
32151-81	5	3	1	Retaining Ring Push-On
32151-83	10	12	1	Ring-Retaining

*Not Illustrated

