



Lawn & Garden Tractor

Model No. 72045 – 7900001 & Up

Parts Catalog

ORDERING REPLACEMENT PARTS

To order replacement parts, please supply: the part number, the quantity, and the description of each part desired.

Contents

Description	Page	Description	Page
Hood and Grill	1	Clutch and Brake — Gear	18
Dash	2	Rear Wheel	19
Steering Wheel and Tilt	3	Peerless Transaxle 820-024 / 820-024A	20
Lower Steering	4	Peerless Transaxle 820-024 / 820-024A	21
Front Axle	5	Crankshaft	22
Seat	6	Crankcase	23
Fuel Tank and Hydro Reservoir	7	Oil Pan / Lubrication	24
Fender and Footrest	8	Cylinder Head / Valve / Breather	25
Hoodstand and Firewall	9	Ignition / Electrical	26
Lift Lever and Height of Cut	10	Blower Housing & Baffles	27
Frame	11	Starting System	28
Gear Drive Components	12	Fuel System	29
Single Cylinder Engine, Muffler, and P.T.O.	13	Engine Controls	30
Clutch 94-2514	14	Air Intake / Filtration	31
Battery	15	Exhaust	32
Transaxle — Gear	16	Electric Schematic Single Cylinder Gear Drive ..	33
Gear Shift Linkage	17	Wire Harness Routing — Single Cylinder Engine	34

Accessories

Description	Model / Parts No.	Description	Model / Parts No.
.. 38" Side Discharge Mower	78216	.. 48" Snow Blade	79252
38" Recycler Mower	78226	42" Snow Thrower	79263
42" Side Discharge Mower	78231	36" Tiller	79271
48" Side Discharge Mower	78260	Hour Meter Kit	92-6898
52" Side Discharge Mower	78280	Indicator Light	92-6897
52" Recycler Mower	78285	Inner Tube, Front	100079
38" Twin Bagger	79202	Inner Tube, Rear	7007
48" Vacuum Bagger	79203		

Part Description Abbreviations

Part descriptions in this catalog may include the following abbreviations.

Abbreviation	Meaning	Abbreviation	Meaning
AR	as required	HH	hex head
ASM	assembly	HHF	hex head flange
CARR	carriage	HHST	hex head self tapping
DEG	degrees	HJ	hex jam
FH	flat head	HOC	height-of-cut
GA	gauge	HS	hex socket
HF	hex flange	HSBH	hex socket button head
HFV	hex head flange	HSFH	hex socket flat head

HSH	hex socket head	SFH	slotted fillister head
HWHTF	hex washer head thread forming	SH	square head
HWH	hex washer head	SHWH	slotted hex washer head
INCL	includes	SPH	slotted pan head
LH	left hand	STD	standard
PH	pan head	TAP	self tapping
PPH	Phillips pan head	TH	truss head
PTO	power take off	TTH	Torx truss head
RH	right hand	WH	wing head

Important Format Explanations

This catalog uses special formats to convey information in illustrations and parts lists. Specifically, one format is used in conjunction with service assemblies and another with quantities associated with reference numbers.

Service Assemblies

Parts within service assemblies have reference numbers in the form $X:Y$. X is the reference number of the service assembly and Y is a sequential number unique to each part within the service assembly.

For example, a wheel assembly might be identified by reference number 6, the tire by 6:1, the valve by 6:2, and the wheel by 6:3. When you order the assembly identified by reference number 6, you receive all parts identified by reference numbers 6:1, 6:2, and 6:3. However, you may also order any part individually.

Reference numbers of this type appear in part lists and as callouts in illustrations.

Reference Numbers with Quantities

Illustrations may have a quantity in parentheses next to a reference number, in the form $X (Y)$. X is the reference number. Y in parentheses is the quantity of the part identified by the reference number.

For example, the illustration callout 4 (2) indicates that two parts are used in that instance.

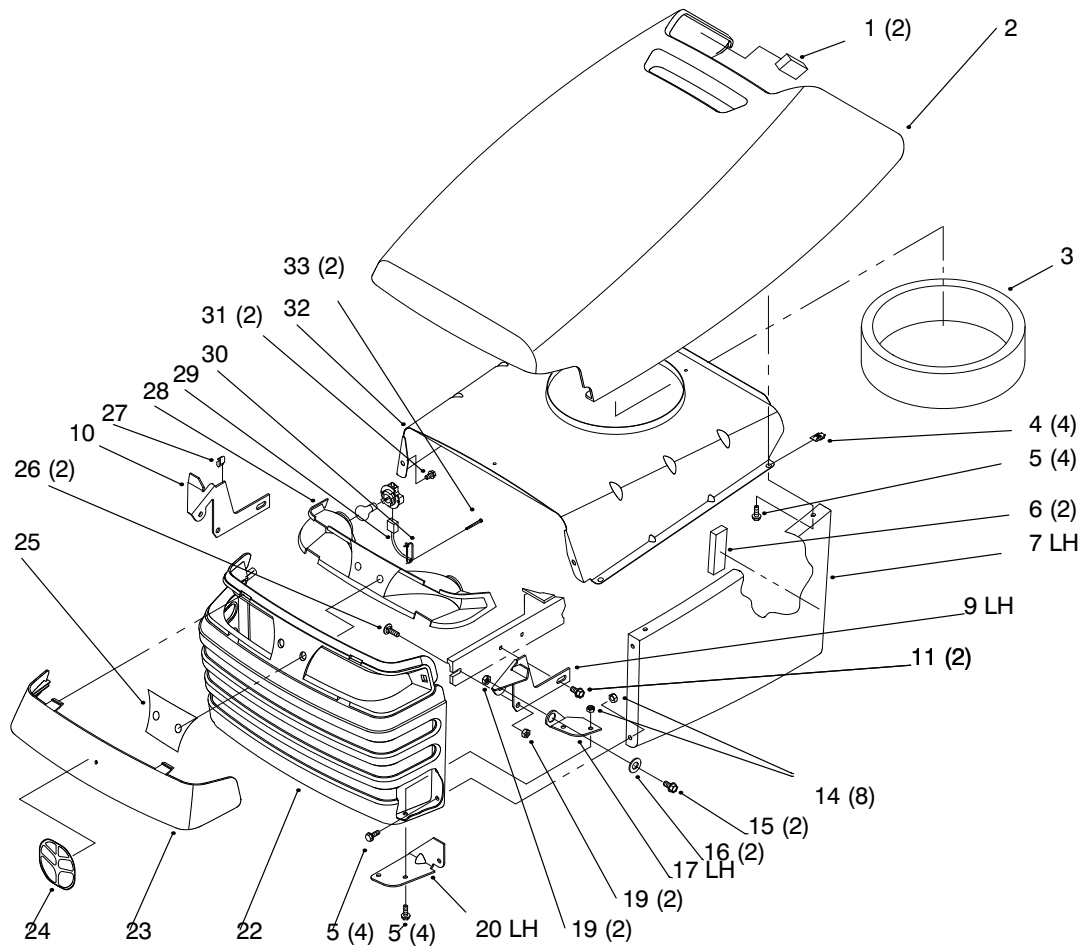

Sheet No.: 2

Hood and Grill

Ref. No.	Part No.	Qty.	Description
1	94-1980	2	Foam-Hood
2	93-0490	1	Hood
3	92-7077	1	Inlet-Seal Air
4	92-7006	4	Nut
5	32105-15	12	Screw-HH
6	92-7148	2	Foam-Sidepanel
7	93-0491	1	Sidepanel-LH Hood
8	93-0492	1	Sidepanel-RH Hood
9	92-6918-03	1	Bracket-Hinge LH
10	92-6917-03	1	Bracket-Hinge RH
11	32144-14	2	Screw-HWH
12	92-6728	1	Decal-Hood LH
13	92-6729	1	Decal-Hood RH
14	32128-10	8	Nut-Lock HHF
15	322-3	2	Screw-HH
16	105503	2	Bushing
17	92-6997-03	1	Hinge-Hood LH
18	92-6996-03	1	Hinge-Hood RH
19	3296-29	4	Nut-Lock
20	92-7049-03	1	Bracket-Hood Hinge LH
21	92-7048-03	1	Bracket-Hood Hinge RH
22	93-0494	1	Grille & Screen ASM
23	92-6656	1	Lens-Headlight
24	92-6987	1	Decal-Horsehead

Ref. No.	Part No.	Qty.	Description
26	3230-1	2	Bolt-CARR
27	702366	1	Clip-Wire Retainer
28	88-3970	1	Reflector-Lamp
29	88-4320	1	Harness-Wire
31	46-8093	2	Screw-TAP
32	92-6914-03	1	Baffle-Hood Upper
33	32144-32	2	Screw-Plastic

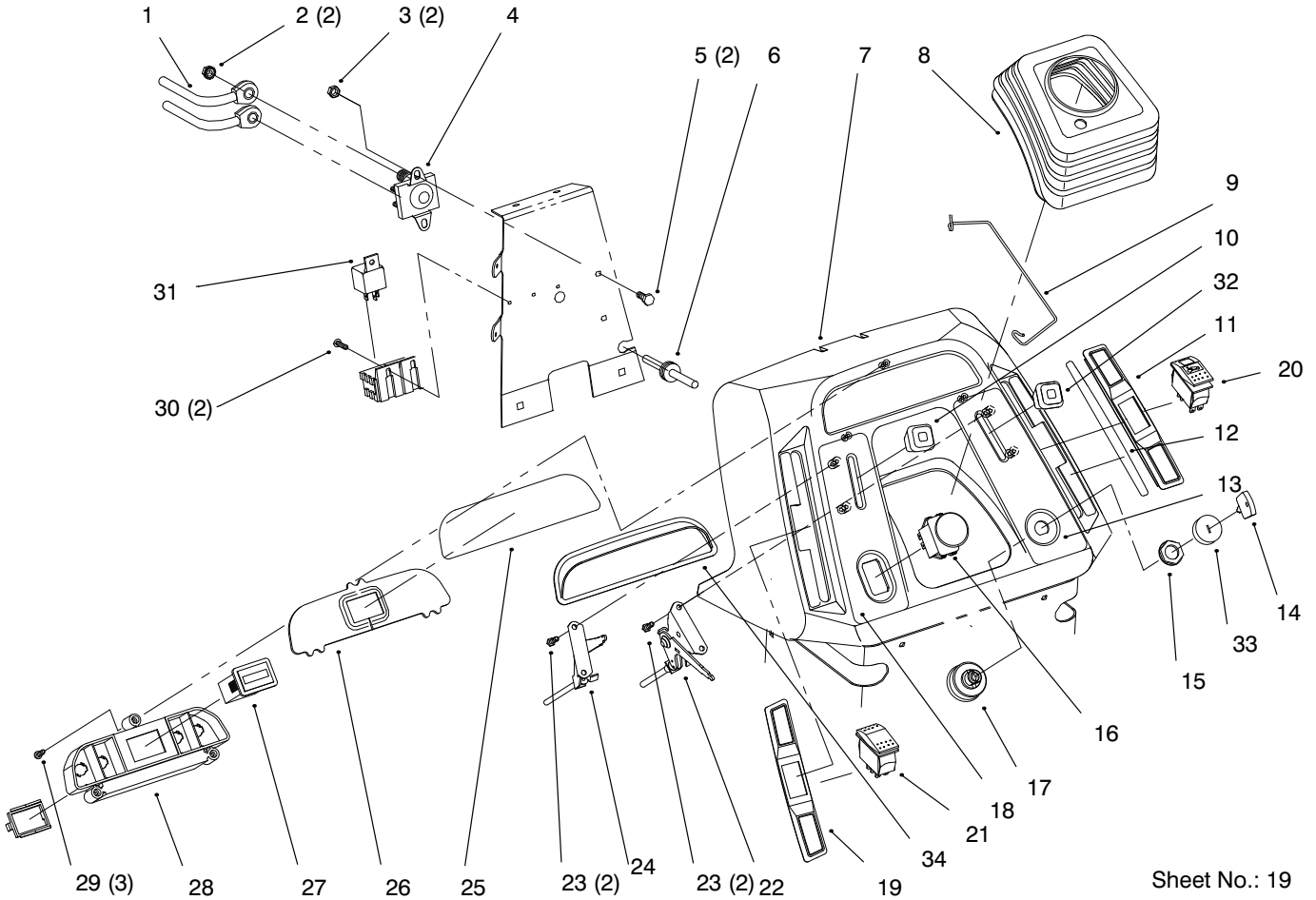

Sheet No.: 19

Dash

Ref. No.	Part No.	Qty.	Description
1	92-6989	1	Cable-Battery Red
2	32149-2	2	Nut-Hex Lock
3	3296-42	2	Nut-Lock
4	92-9845	1	Solenoid
5	321-4	2	Screw-HH
6	237-141	1	Grommet
7	94-1895	1	Dash-Gear
8	92-6680	1	Boot-Steering
9	94-2966	1	Clip-Boot
10	66-0120	2	Knob
12	92-6722	1	Decal-Shift
13	92-6721	1	Decal-Throttle/Ignition
14	62-7770	1	Key-Ignition
15	700919	1	Nut
16	93-9998	1	Switch-PTO
17	92-6785	1	Switch-Ignition
18	92-6720	1	Decal-Choke/PTO
19	92-6797	1	Cover-Slot LH
22	92-6782	1	Control-Throttle
23	32144-32	4	Screw-Plastic
24	92-6781	1	Control-Choke
25	92-6975	1	Decal-Dash Lens
26	92-6705	1	Lens-Dash
27	94-4208	1	Hourmeter
28	92-6732	1	Housing-Indicator Light

Ref. No.	Part No.	Qty.	Description
29	94-6961	3	Screw
30	32144-8	2	Screw-PPH
31	116397	2	Relay

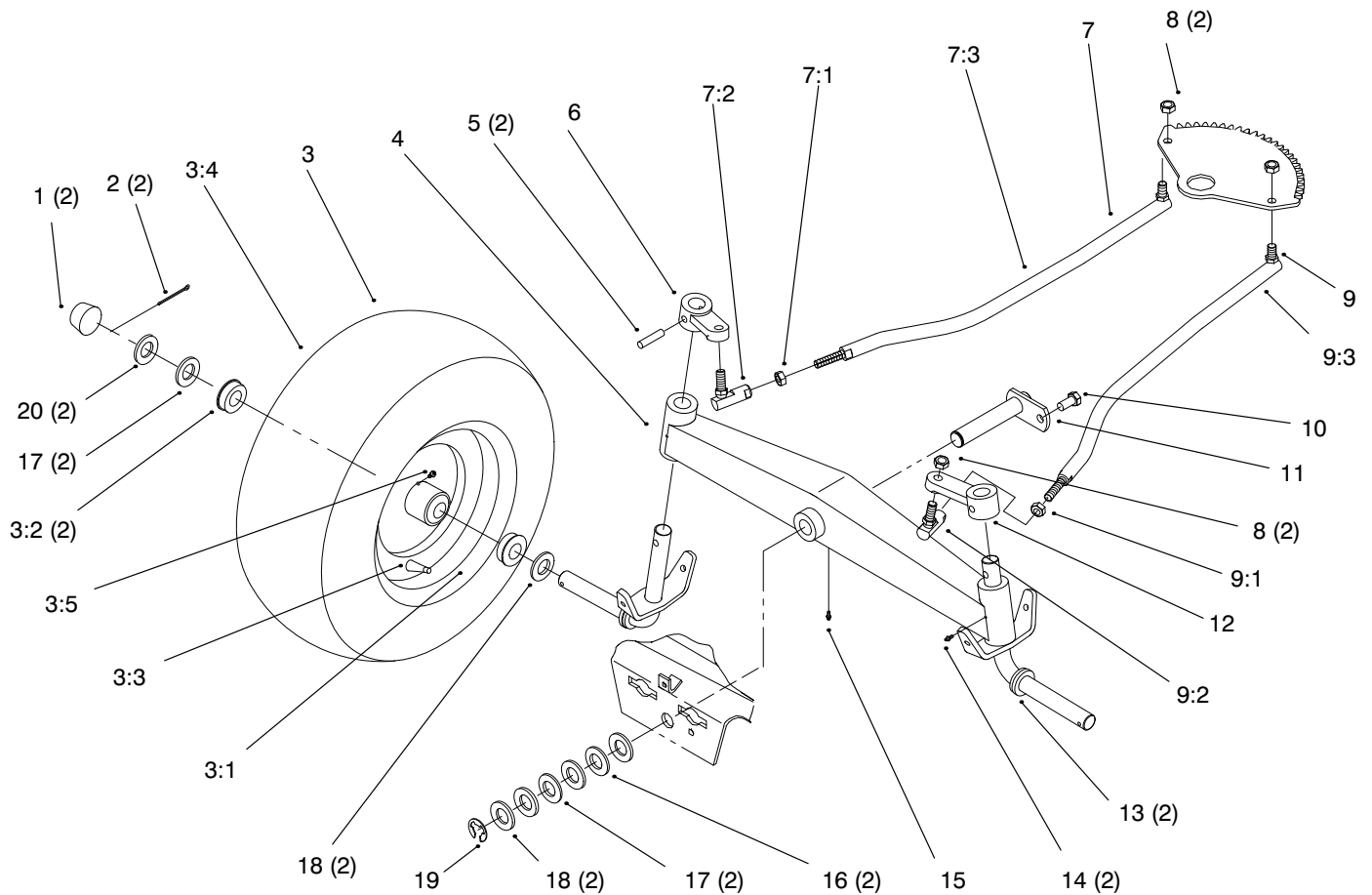

Sheet No.: 4

Front Axle

Ref. No.	Part No.	Qty.	Description
1	61-9780	2	Hubcap
2	3272-17	2	Pin-Cotter
☆3	93-9800	2	ASM-Wheel & Tire
3:1	93-9801	2	ASM-Wheel w/Zerk
3:2	110513	4	Bearing-Wheel
3:3	5108	2	Valve-Tire Tubeless
3:4	117127	2	Tire
3:5	109500	2	Fitting-Grease
4	78-7960-01	1	Axle-Front
5	933270	2	Pin-Roll
6	78-1950-01	1	Arm-Front Spindle LH
7	92-6883	1	Steering Link RH
☆7:1		1	Nut-Hex Jam
7:2	78-2920	1	Joint-Ball
7:3	78-5801	1	Joint-Ball RH w/ Jam Nut
8	9150026	4	Nut-Lock
9	92-6884	1	Steering Link LH
☆9:1		1	Nut-Hex Jam
9:2	78-2920	1	Joint-Ball
9:3	78-5811	1	Joint-Ball LH
10	9267154	1	Screw
11	92-7057-03	1	Pin-Front
12	78-1940-01	1	Arm-Front Spindle RH
13	78-2601-01	2	Spindle
14	302-5	2	Fitting-Grease

Ref. No.	Part No.	Qty.	Description
15	302-11	1	Fitting-Grease
16	9202324	2	Washer-10 GA
17	1278	4	Washer-Shim
18	5210	4	Washer-Shim
19	5618	1	Ring-Retaining
20	28-2480	2	Washer-Flat

☆ Not serviced

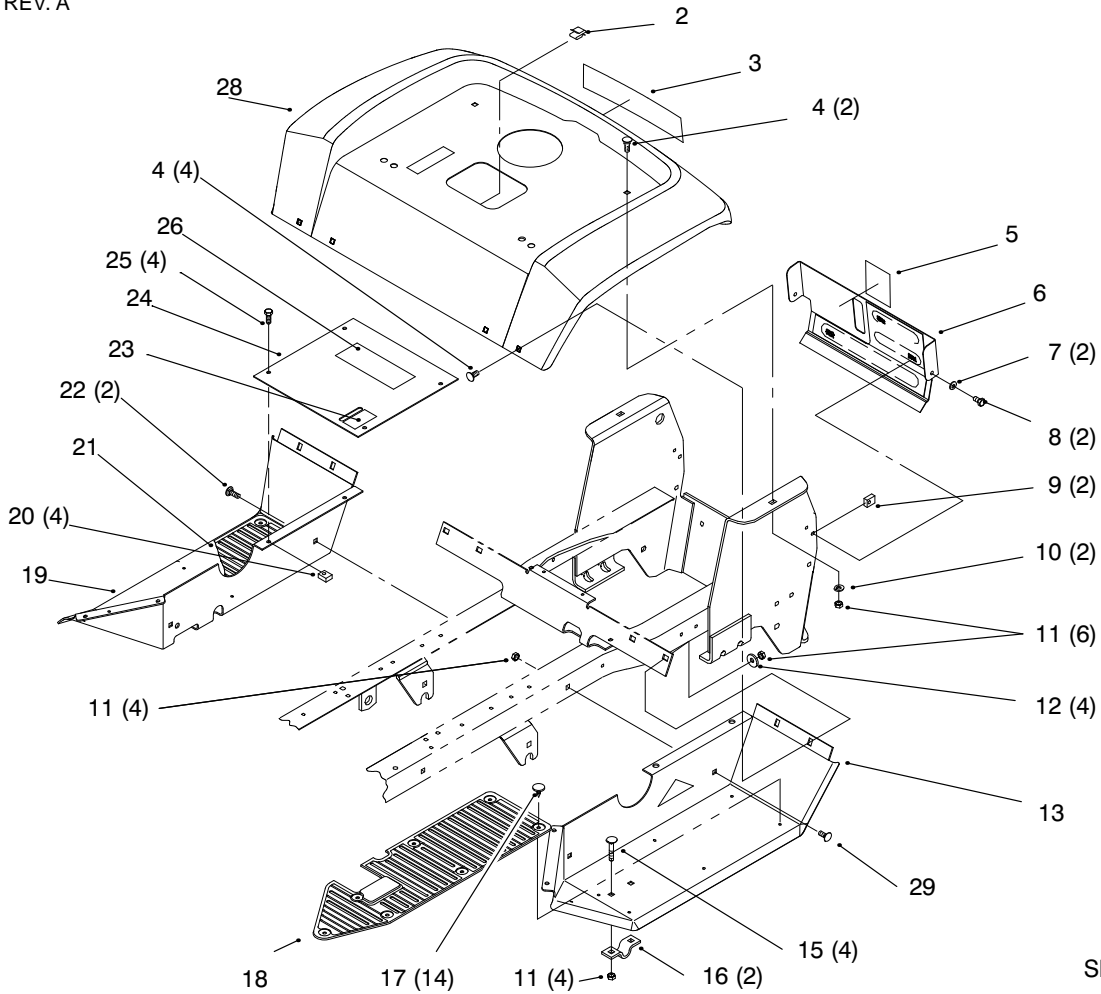

Sheet No.: 17

Fender and Footrest

Ref. No.	Part No.	Qty.	Description
2	702366	1	Clip-Wire Retainer
3	92-6730	1	Decal-Rear Fender
4	3230-31	6	Screw-CARR
5	92-6727	1	Decal-Fuel Level
6	94-1717-03	1	Panel-Rear
7	3256-22	2	Washer-Flat
8	321-4	2	Screw-HH
9	609900	2	Nut-Speed
10	3256-23	2	Washer-Flat
11	3296-29	14	Nut-Lock
12	94-2869	4	Washer-Flat
13	92-6745-01	1	Footrest-LH
15	3230-20	4	Bolt-CARR
16	106288	2	Clamp
17	3290-479	14	Fastener-Panel
18	92-6690	1	Mat-Foot LH
19	92-6744-01	1	Footrest-RH
20	107069	4	Nut-Retainer
21	92-6689	1	Mat-Foot RH
22	3230-23	3	Bolt-CARR
23	92-6725	1	Decal-HOC
24	93-0489-01	1	Plate-Footerest w/Decal
25	92-7020	4	Screw-TTH
26	92-8946	1	Decal-Danger
27	76-1340	1	Decal-USA

Ref. No.	Part No.	Qty.	Description
28	92-6795-01	1	Fender
29	3230-2	1	Screw-CARR

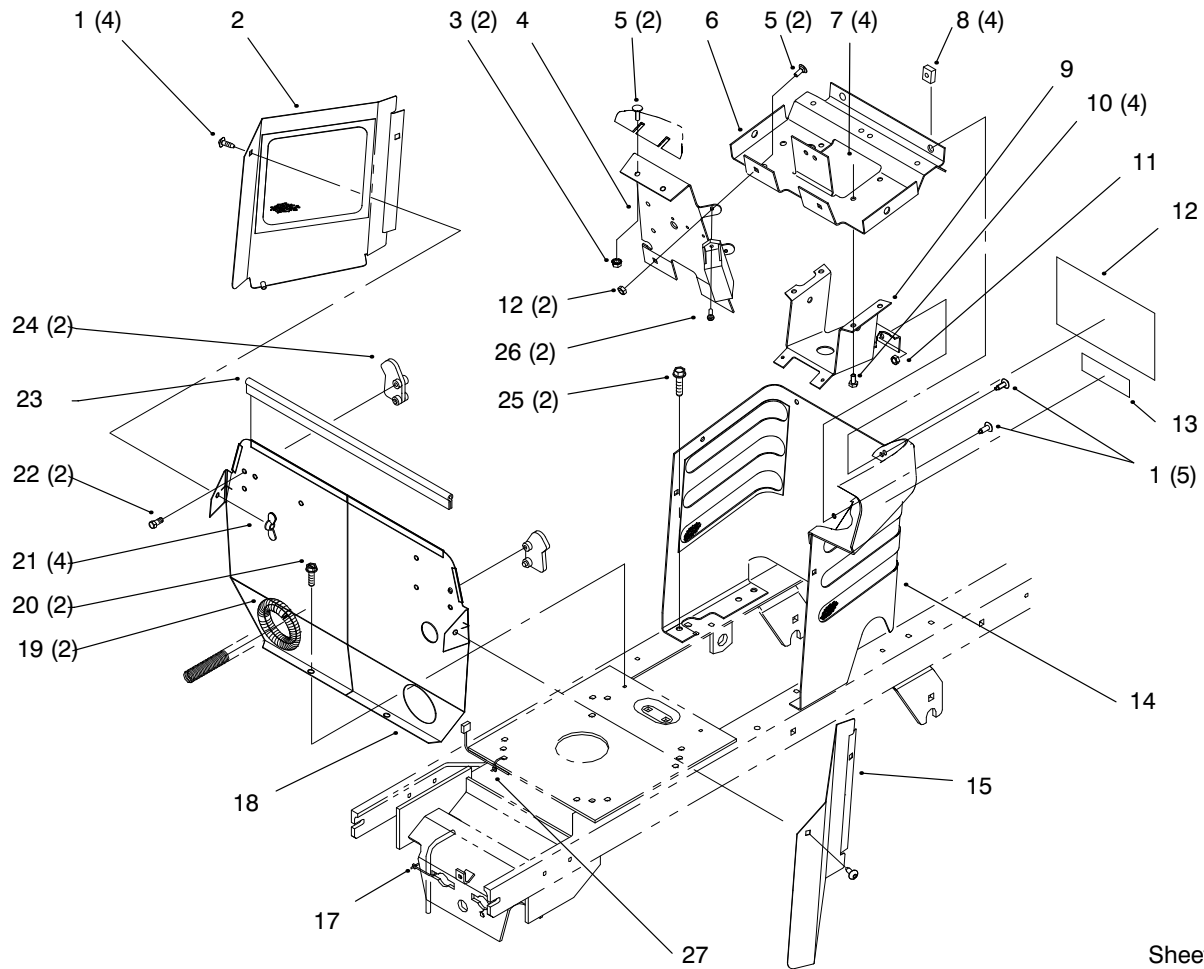

Sheet No.: 10

Hoodstand and Firewall

Ref. No.	Part No.	Qty.	Description	Ref. No.	Part No.	Qty.	Description
1	92-7020	9	Screw-TTH				
2	92-6937-03	1	Cover-Side RH				
3	32149-2	2	Nut-Hex Lock				
4	94-1712-03	1	Panel-Support				
5	3229-11	4	Bolt-CARR				
6	92-6859-03	1	Support-Dash				
7	3296-8	4	Nut-Lock				
8	92-6860	4	Nut-Retainer				
9	92-6778-03	1	Support-Column				
10	321-4	4	Screw-HH				
11	3296-42	3	Nut-Lock				
12	93-0301	1	Decal-Slope/Park Brake				
13	83-6620	1	Decal-Instruction				
14	93-0485-03	1	Hoodstand w/Decals				
15	92-6936-03	1	Cover-Side LH				
16	94-2972	2	Decal-265-6				
18	94-1749-03	1	Firewall				
19	24-7924	2	Cover-Drive Shaft				
20	32144-4	2	Screw-TAP				
21	32103-22	4	Nut-Wing				
22	46-8093	2	Screw-TAP				
23	93-1131	1	Trim-Seal				
24	92-6960	2	Latch-Hood				
25	32144-14	2	Screw-HWH				
26	32144-8	2	Screw-PPH				

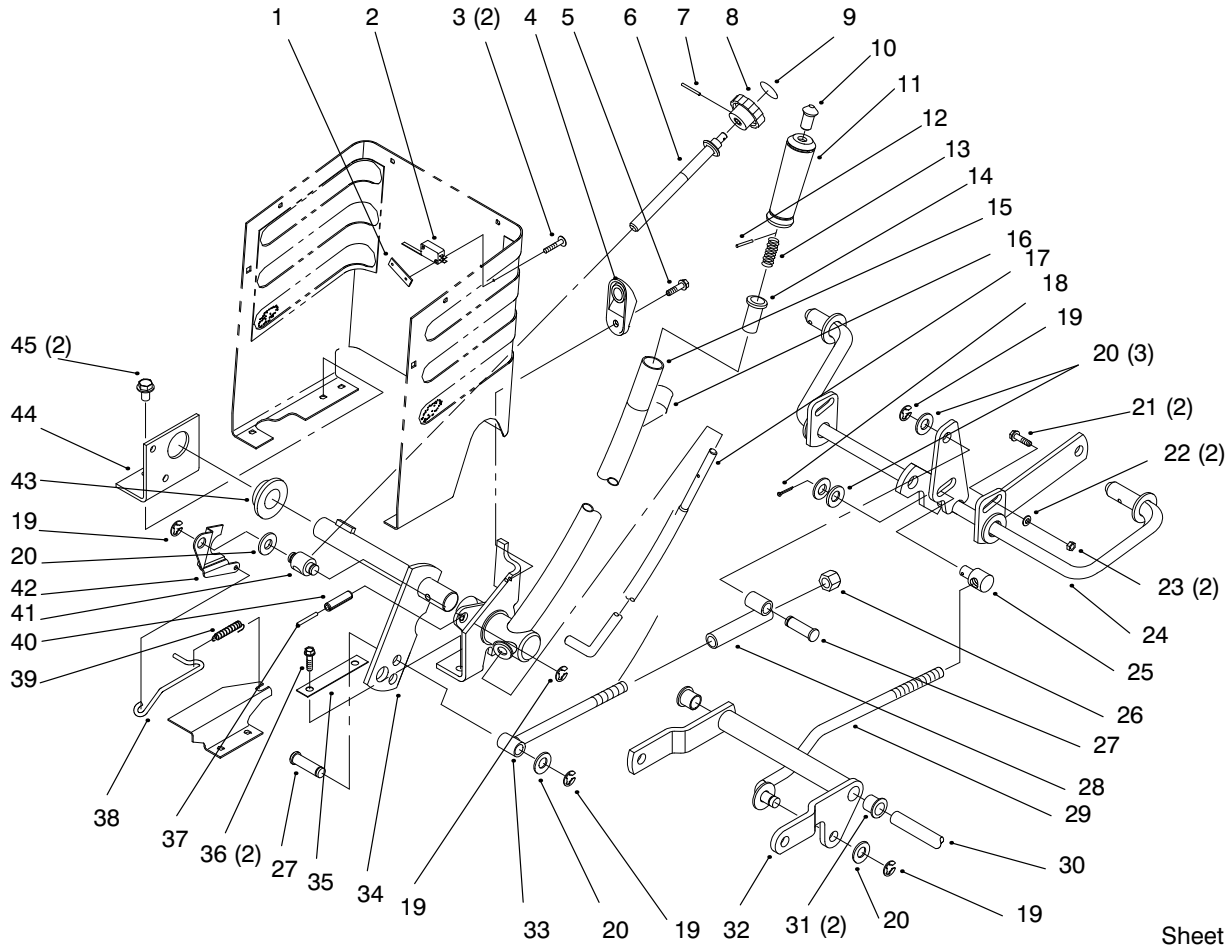

Sheet No.: 11

Lift Lever and Height of Cut

Ref. No.	Part No.	Qty.	Description
1	3290-354	1	Nut-Speed
2	88-9930	1	Switch-Micro
3	95-3003	2	Screw
4	92-6794	1	Wedge-HOC Adjust
5	32144-4	1	Screw-TAP
6	92-6965	1	Rod-HOC
7	933141	1	Pin-Spirol
8	115593	1	Knob
9	78-9740	1	Decal-HOC Knob
10	92-6711	1	Tip-Rod
11	92-6710	1	Grip-Handle
12	933148	1	Pin-Spirol
13	3624	1	Spring-Compression
14	8130	1	Retainer-Spring
15	94-3761-03	1	Lift Lever Wa
16	112168	1	Decal-Lift
17	92-6977-03	1	Rod-Lift Lever
18	3272-6	1	Pin-Cotter
19	32120-47	5	Ring-Retaining
20	3256-26	6	Washer-Flat
21	3231-25	2	Screw-CARR
22	3256-24	2	Washer-Flat
23	3296-39	2	Nut-Lock
24	79-3401-03	1	Gage Shaft
25	8870	1	Trunnion
26	3296-23	1	Nut-Lock

Ref. No.	Part No.	Qty.	Description
27	79-1250	2	Pin
28	78-7390	1	Link
29	78-2431	1	Rod
30	94-4944	1	Shaft
31	256-90	2	Bushing-Flange
32	92-6855-03	1	Arm
33	78-7360	1	Rod
34	94-3552-03	1	Lift Arm
35	78-6810-03	1	Plate
36	32144-14	2	Screw-HWH
37	32121-103	1	Pin-Spring
38	92-6978	1	Rod-HOC Indicator
39	92-7007	1	Spring-Extension
40	32121-25	1	Pin-Roll
41	78-2140	1	Trunnion
42	92-6979	1	Plate-HOC Gage
43	106269	1	Bearing-Flange
44	93-0523-03	1	Bracket-Pivot Linkage
45	32144-70	2	Screw-TAP

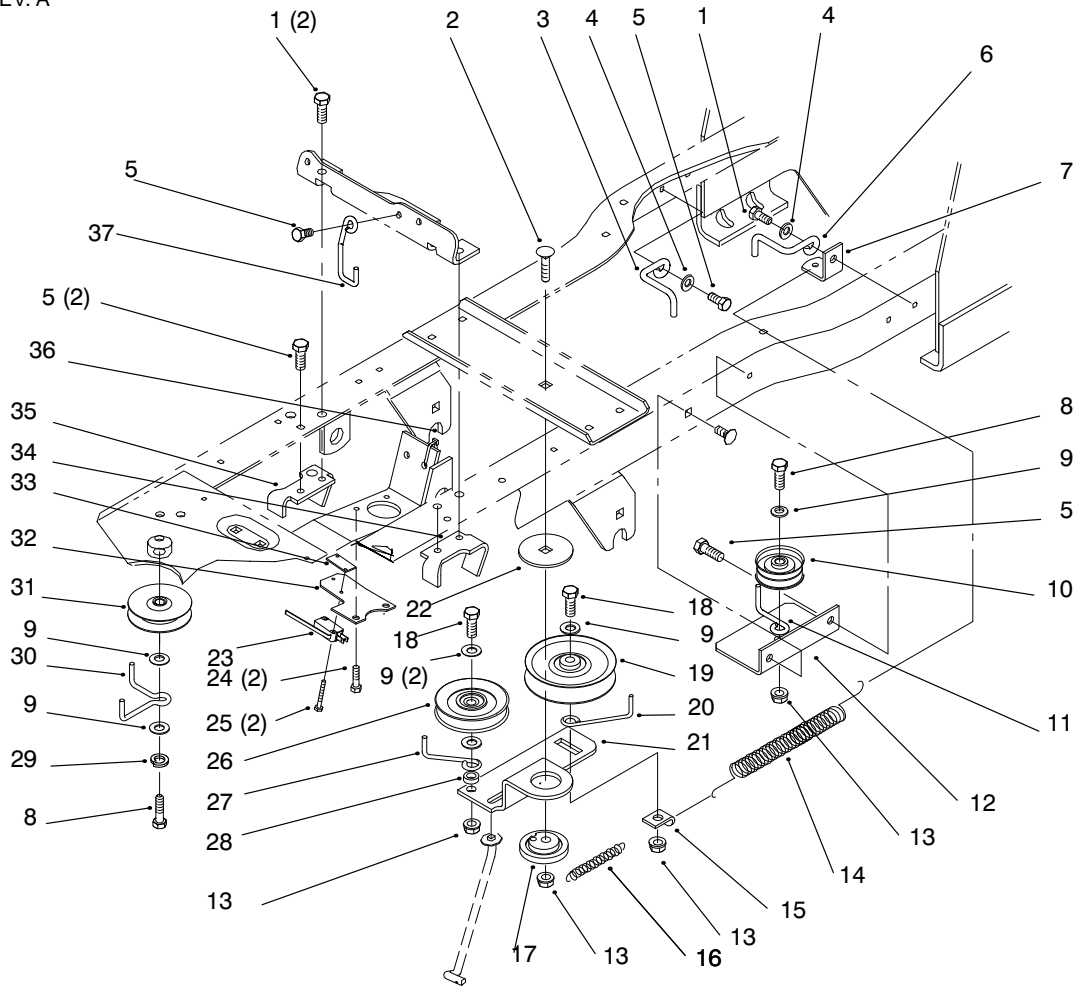

Sheet No.: 21

Gear Drive Components

Ref. No.	Part No.	Qty.	Description
1	32144-70	3	Screw-TAP
2	3231-25	1	Screw-CARR
3	92-7001	1	Guide-Belt RH
4	3256-23	2	Washer-Flat
5	32144-14	5	Screw-HWH
6	92-7002	1	Guide-Belt LH
7	92-6891-03	1	Bracket-Idler Spring
8	323-9	2	Screw-HH
9	3256-24	6	Washer-Flat
10	607978	1	Pulley-Idler
11	93-0549	1	Guide-Belt
12	92-6894-03	1	Bracket-Idler Rear
13	3296-39	4	Nut-Lock
14	79-7530	1	Spring-Extension
15	2534	1	Clip-Spring
16	107788	1	Spring-Extension
17	111418	1	Bushing
18	323-10	2	Screw-HH
19	92-7101	1	Pulley-Flat
20	79-0390	1	Guide-Belt
21	78-6771	1	Arm-Idler
22	111419	1	Washer-Bearing
23	88-9932	1	Switch - Micro
24	32144-4	2	Screw-TAP
25	147665	2	Screw
26	92-7102	1	Pulley-Idler
27	79-0400	1	Guide-Belt
28	93-3658	1	Spacer

Ref. No.	Part No.	Qty.	Description
29	3253-5	1	Washer-Lock
30	93-0547	1	Guide-Belt
31	93-0320	1	Pulley-Idler
32	93-0526-03	1	Bracket-Micro Switch
33	3290-354	1	Nut-Speed
34	92-6670	1	Bracket-Clutch
35	92-6671	1	Bracket-Brake
37	93-0548	1	Guide-Belt

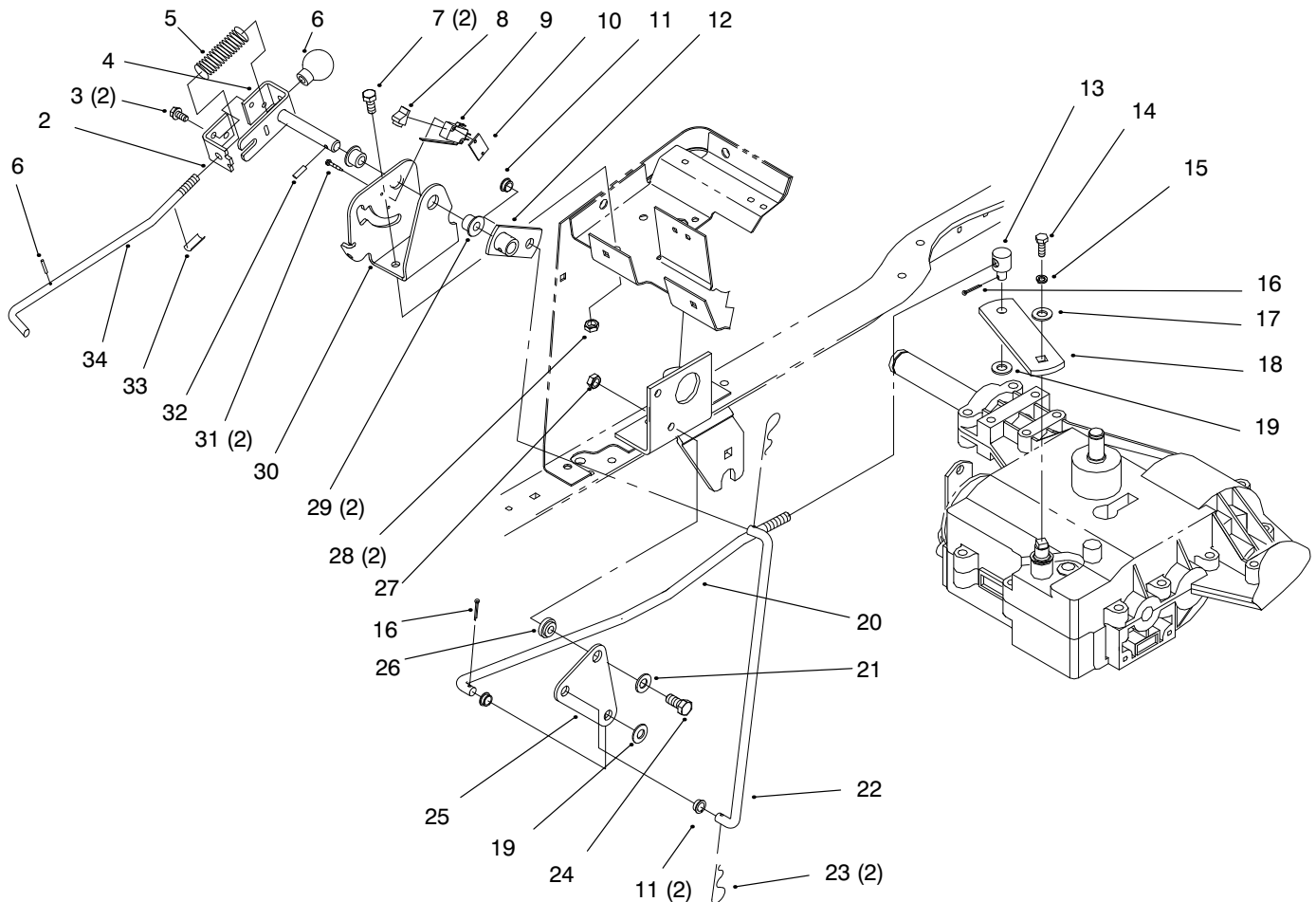

Sheet No.: 20

Gear Shift Linkage

Ref. No.	Part No.	Qty.	Description	Ref. No.	Part No.	Qty.	Description
1	32121-97	1	Pin-Roll	28	3296-29	2	Nut-Lock
2	92-6921	1	Bracket-Shaft	29	256-219	2	Bushing
3	32144-4	2	Screw-TAP	30	93-0503-03	1	Bracket-Pivot Mount
4	92-6919	1	Pivot-Shift	31	147665	2	Screw
5	3624	1	Spring-Compression	32	32121-4	1	Pin-Roll
6	233-42	1	Knob	33	93-3141	1	Decal-Reverse Shift
7	322-3	2	Screw-HH	34	92-6920	1	Rod-Shift
*9	115230	1	Switch-Clutch				
10	3290-354	1	Nut-Speed				
11	92-6875	3	Bearing-Shift Link				
12	92-6926-03	1	Tube-Linkage				
13	110656	1	Trunnion				
14	329-23	1	Screw				
15	3253-3	1	Washer-Lock				
16	3272-6	2	Pin-Cotter				
17	7-5461	1	Spacer-Transmission				
18	92-6886	1	Arm-Shift				
19	3256-24	2	Washer-Flat				
20	92-6896	1	Rod-Shift Transaxle				
21	3256-71	1	Washer-Flat				
22	92-7005	1	Rod				
23	3290-307	2	Pin-Cotter				
24	322-5	1	Screw-HH				
25	93-0524	1	Bracket-Pivot				
26	105503	1	Bushing				
27	3296-29	1	Nut-Lock				

* Refer to Lawn/Yard Tractor Service Bulletin for early models with black switches (P/N, Removal, Installation).

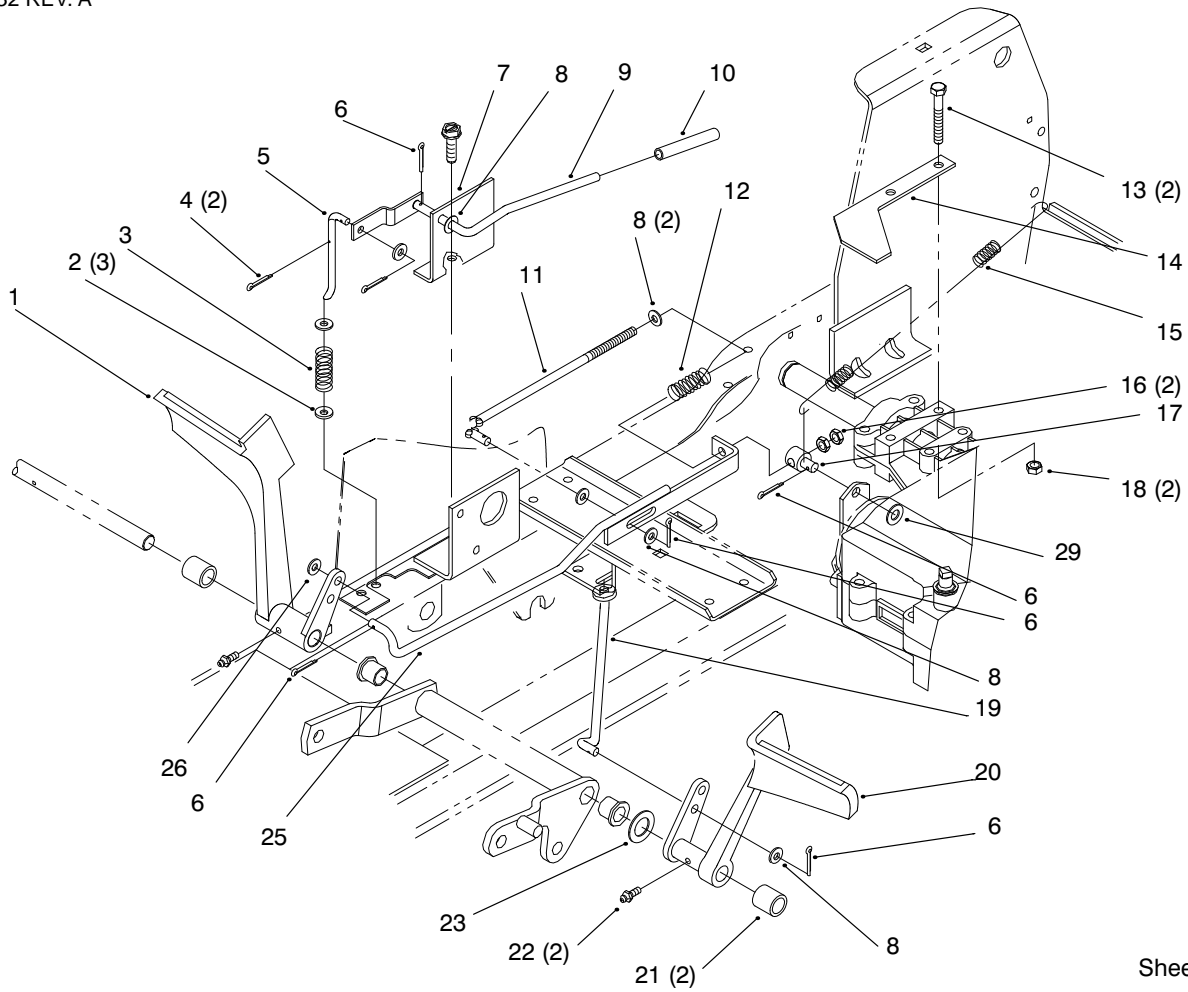

Sheet No.: 22

Clutch and Brake — Gear

Ref. No.	Part No.	Qty.	Description
1	93-3228-03	1	Pedal-Brake
2	3256-22	3	Washer-Flat
3	92-7116	1	Spring-Compression
4	3272-2	2	Pin-Cotter
5	92-7019	1	Rod-Park Brake
6	3272-6	5	Pin-Cotter
7	92-6929-03	1	Bracket-Parking Brake
8	3256-23	5	Washer-Flat
9	92-6931	1	Lever-Parking Brake
10	92-7009	1	Grip-Parking Brake
11	94-1729	1	Rod-Spring
12	94-1734	1	Spring-Compression
13	322-11	2	Screw-HH
14	94-1723-03	1	Stop-Brake
15	94-1733	1	Spring-Extension
16	3218-2	2	Nut-Hex Jam
17	94-2688	1	Trunnion
18	3296-29	2	Nut-Lock
19	92-6924	1	Rod-Clutch
20	78-8180-03	1	Pedal-Clutch
21	94-1862	2	Spacer
22	302-5	2	Fitting-Grease
23	111712	1	Washer-Wave
25	95-3039-03	1	Brake Arm Wa

Ref. No.	Part No.	Qty.	Description
26	3256-3	1	Washer-Flat
29	3256-24	1	Washer-Flat

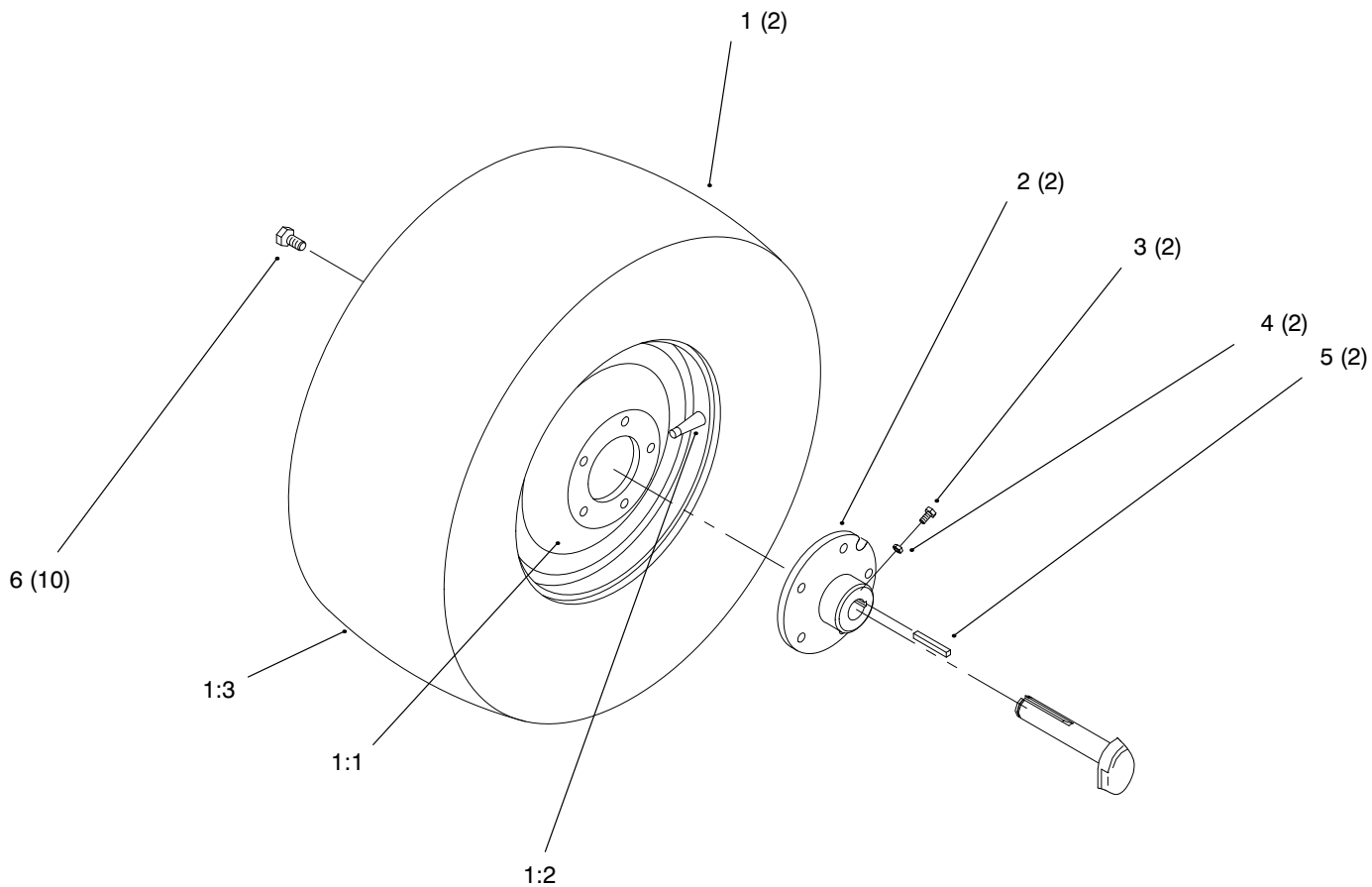

Sheet No.: 24

Rear Wheel

Ref. No.	Part No.	Qty.	Description
☆1		2	Wheel & Tire ASM
1:1	78-1221	2	Wheel
1:2	5108	2	Valve-Tire Tubeless
1:3	116744	2	Tire
2	93-3659-03	2	Hub-Wheel
3	3243-5	4	Screw-Set
4	3218-3	4	Nut-HJ
5	5-1336	2	Key
6	83-2720	10	Bolt-Lug

Ref. No.	Part No.	Qty.	Description

☆ Not serviced

Peerless Transaxle 820-024 / 820-024A

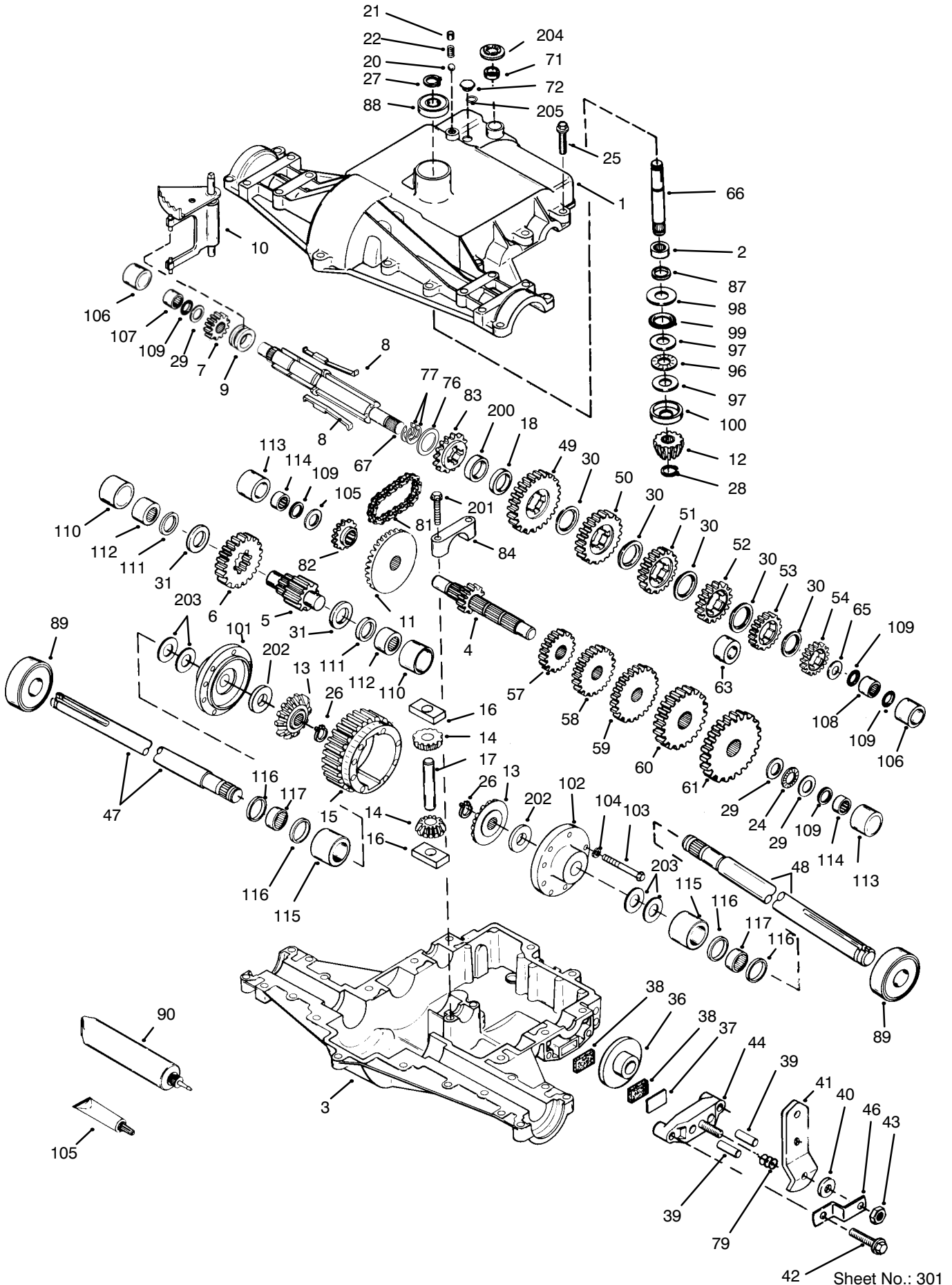

Peerless Transaxle 820-024 / 820-024A

Ref. No.	Part No.	Qty.	Description	Ref. No.	Part No.	Qty.	Description
1	772098A	1	Cover-Transaxle	58	778200	1	Gear Spur 20t
2	780155	1	Bearing-Needle	59	778201	1	Gear Spur 25t
3	770088	1	Case-Transaxle	60	778202	1	Gear Spur 28t
4	776291	1	Countershaft-Gear 9t	61	778222	1	Gear Spur 30t
5	776275	1	Shaft-Output	65	780109	1	Washer
6	778247	1	Gear-Output 35t	66	776293	1	Shaft-Input 30.910" Lg
7	778253	1	Gear-Spur 15t	67	776313	1	Shaft-Shifter/Brake (820-024 Only)
8	792138	4	Key-Shift (820-024 Only)	67	776385	1	Shaft-Shifter/Brake (820-024A Only)
8	792180	4	Key-Shift (820-024A Only)	71	788069	1	Ring-Square Cut
9	784216	1	Collar-Shift (820-024 Only)	72	792165	1	Plug-Threaded 5/16-18
9	784352	1	Collar-Shift (820-024A Only)	76	780090	1	Washer-Flat (820-024A Only)
10	784342	1	Fork-Shift (820-024 Only)	77	788078A	2	Ring-Retaining (820-024A Only)
10	784375	1	Fork-Shift (820-024A Only)	79	792144	1	Spring
11	778246	1	Gear-Bevel 33t	81	786062A	1	Chain-Roller #41 22" Lg
12	778245	1	Pinion-Input Bevel 13t	82	786061	1	Sprocket 10t
13	778198	2	Gear-Bevel 16t	83	786124	1	Sprocket-Reverse 14t
14	778197	2	Pinion-Bevel 10t	84	786131	1	Cap-Bearing
15	778248	1	Gear-Ring	87	788042	1	Seal-Oil 3/4"
16	786027	2	Block-Drive	88	780119	1	Bearing-Ball
17	786019	1	Pin-Drive	89	780050	2	Bearing-Ball
18	786121	1	Spacer .350-.340 Thick	90	788067B	1	Grease 32 Oz Bentonite
20	792077	1	Ball-Steel	96	780084	1	Bearing-Thrust
21	792078	1	Screw-Set 3/8-16x3/8	97	780051	2	Washer
22	792079	1	Spring	98	780165	1	Washer
24	780071	1	Bearing-Thrust	99	788077	1	O Ring
25	792129A	17	Screw 5/16-18x1 1/4	100	780166	1	Washer-Cupped
26	792018	2	Ring-Retaining	101	774833	1	Carrier-Differential
27	792018	1	Ring-Retaining	102	774834	1	Carrier-Differential
28	788040	1	Ring-Retaining	103	792020	8	Screw 14-20x2 1/4
29	780072	3	Washer	104	792006	8	Washer-Lock
30	780108	5	Washer	105	780153	1	Washer
31	780128	2	Washer	106	786144	1	Sleeve
36	790043	1	Disk	107	780152	1	Bearing-Needle
37	790007	1	Plate-Brake Pad	108	780150	1	Bearing-Needle
38	799021	1	Pad-Brake 2/Pkg	109	792001	5	O Ring
39	786026	2	Pin-Dowel	110	786142	2	Sleeve
40	792076A	1	Washer	111	788071	2	Ring-Square Cut
41	790013	1	Lever-Brake	112	780168	2	Bearing-Needle
42	792073	2	Screw 1/4-20x1 1/4	113	786143	2	Sleeve
43	792075	1	Nut-Lock 5/16x24	114	780151	2	Bearing-Needle
44	790025	1	Holder-Brake Pad	115	786145	2	Sleeve
46	786086	1	Bracket-Brake Lever	116	788070	4	Ring-Square Cut
47	774958	1	Axle 12 9/16" Long	117	780031	2	Bearing-Needle
48	774959	1	Axle 16 7/16" Long	150	510334	1	Gasket Loctite #515
49	778216A	1	Gear-Spur 41t	200	786122	1	Spacer .276-.268 Thick
50	778206A	1	Gear-Spur 35t	201	792073	2	Screw 1/4-20x1 1/4
51	778205A	1	Gear-Spur 30t	202	780107	2	Washer
52	778204A	1	Gear Spur 25t	203	780042	4	Washer
53	778203A	1	Gear Spur 22t	204	792145	1	Nut-Push
54	778273	1	Gear Spur 19t	205	780091	1	O Ring
57	778199	1	Gear Spur 15t				

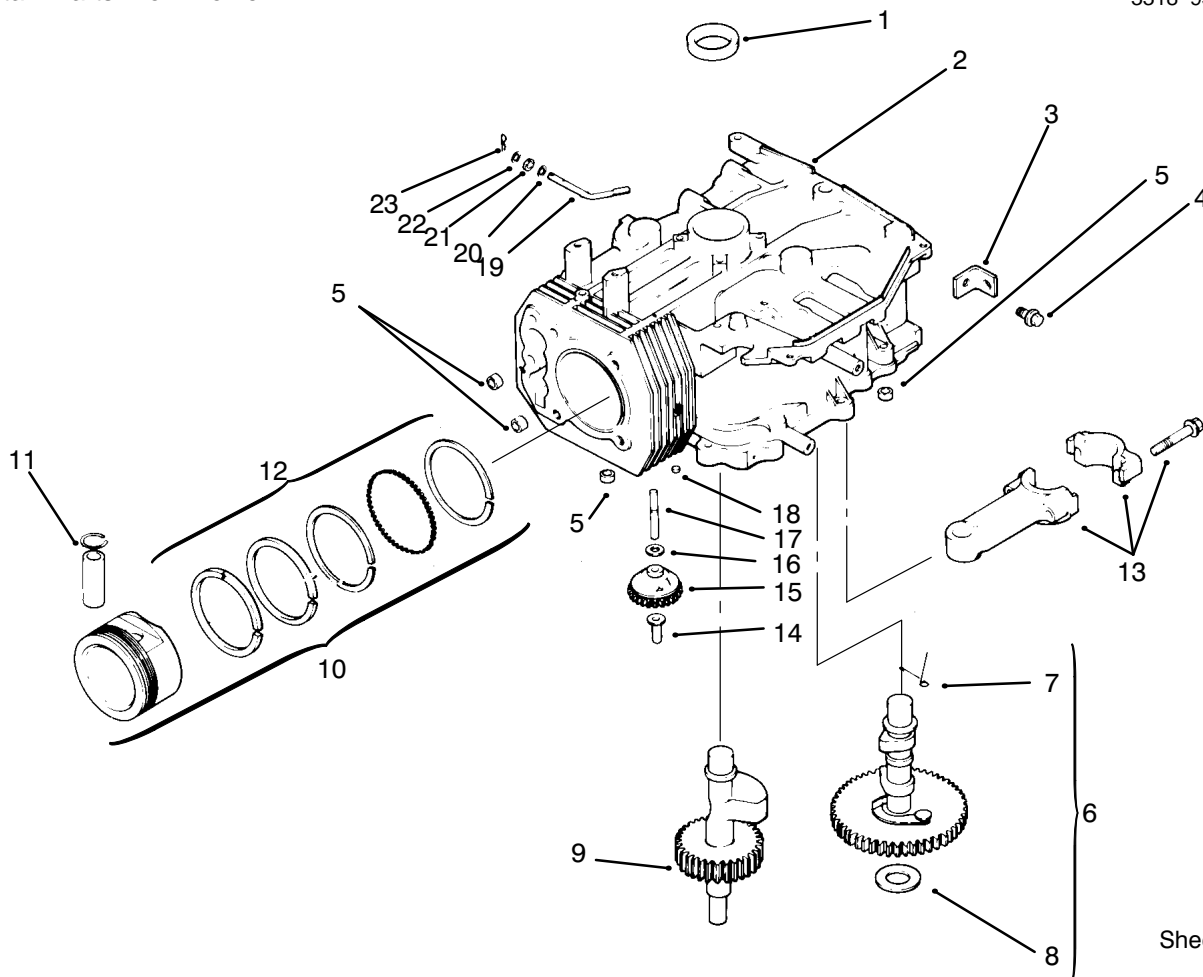

Sheet No.: 102
C-1949

Crankcase

Ref. No.	Part No.	Qty.	Description
1	12 032 03	1	Seal-Crankshaft
2	12 522 18	1	Block-Short
3	12 445 02	1	Strap-Lifting
4	M-0839025	1	Screw M8x1.25x22
5	12 380 03	4	Dowel-Locating
6	12 755 49	1	Kit-Camshaft INC 7-8
†7	12 089 18	1	Spring-Actuating
†8	12 422 07	1	Shim-Camshaft A/R
†8	12 422 08	1	Shim-Camshaft A/R
†8	12 422 09	1	Shim-Camshaft A/R
†8	12 422 10	1	Shim-Camshaft A/R
†8	12 422 11	1	Shim-Camshaft A/R
†8	12 422 12	1	Shim-Camshaft A/R
†8	12 422 13	1	Shim-Camshaft A/R
9	12 144 27	1	Shaft-Balance
10	12 874 07	1	Piston ASM STD Incl 11-2
10	12 874 08	1	Piston ASM .25 Incl 11-2
10	12 874 09	1	Piston ASM .50 Incl 11-2
†11	12 018 02	2	Retainer-Piston Pin
12	12 018 07	1	Ring Set STD
12	12 018 08	1	Ring Set .25
12	12 018 09	1	Ring Set .50

Ref. No.	Part No.	Qty.	Description
13	12 067 05	1	Rod Connecting STD
13	12 067 06	1	Rod Connecting .25
14	12 380 01	1	Pin-Governor Regulating
15	12 043 05	1	Gear-Governor ASM
16	M-0631005	1	Washer-Governor
17	12 144 02	1	Shaft-Governor Gear
18	52 139 09	1	Plug-Cup
19	12 755 64	1	Shaft-Governor Cross
20	M-0631015	1	Washer-Governor Shaft
21	12 032 01	1	Seal-Governor Shaft
22	X-25-102	1	Washer-Flat
23	12 154 05	1	Pin-Governor Hitch
*	12 722 59	1	Gasket Set

† Included in a service kit or in an assembly

* Not illustrated

3318-932 REV. A

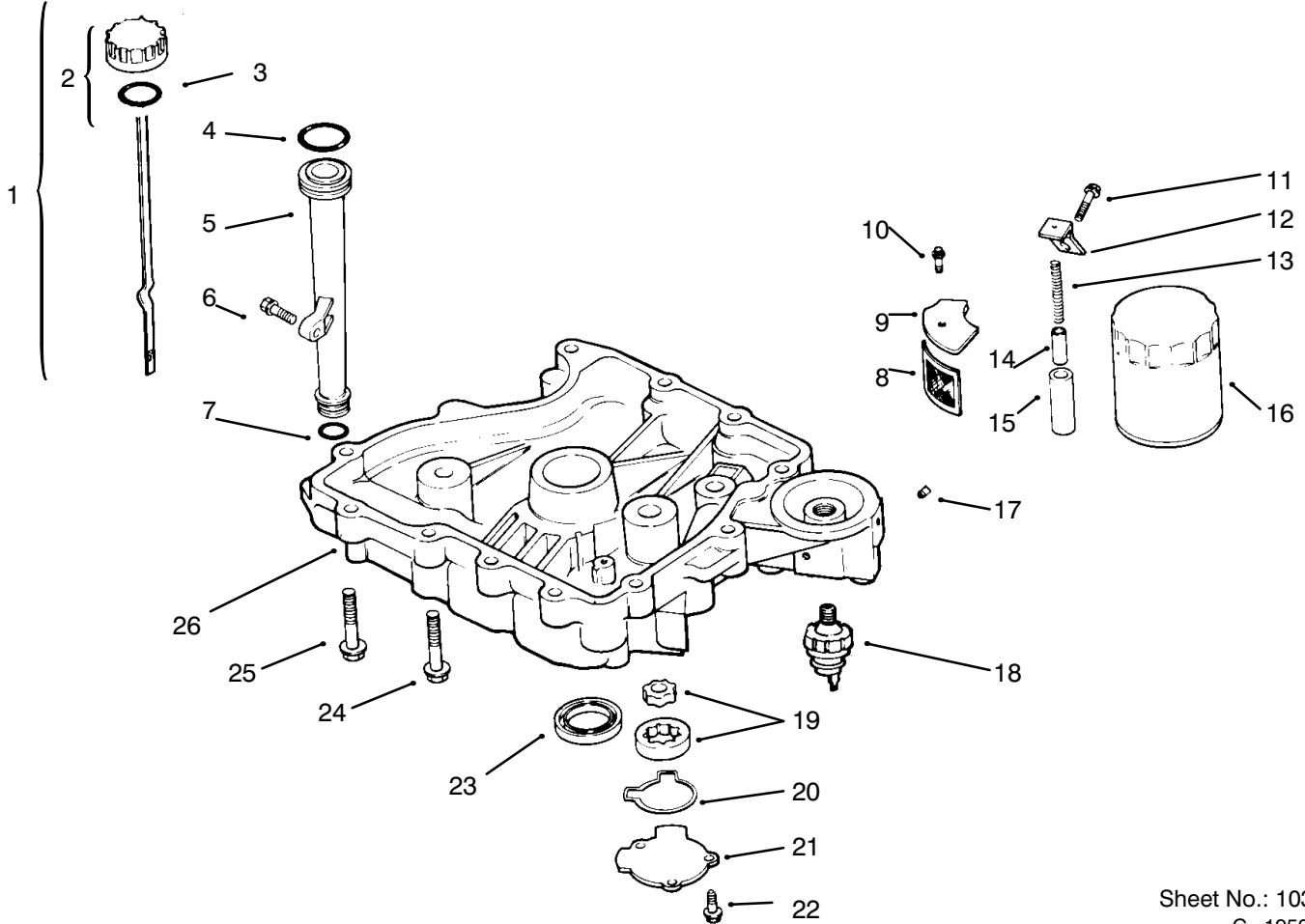

Sheet No.: 103
C-1950

Oil Pan / Lubrication

Ref. No.	Part No.	Qty.	Description
1	12 038 01	1	Dipstick INC 2-3
†2	25 755 13	1	Kit-Oil Cap INC 3
†3	12 153 03	1	O Ring-Fill Cap
4	12 153 02	1	O Ring-Upper Fill Tube
5	12 123 04	1	Tube-Oil Fill
6	M-0545020	1	Screw M5x0.8x20
7	12 153 01	1	O Ring-Lower Fill Tube
8	12 162 07	1	Screen-Oil Pickup
9	12 096 03	1	Cover-Oil Pickup Screen
10	M-0545016	1	Screw M5x0.8x16
11	M-1039025	1	Screw M10x1.5x25
12	12 126 02	1	Bracket-Oil Pump Relief
13	12 089 03	1	Spring-Oil Relief Valve
14	12 462 01	1	Piston-Oil Relief Valve
15	12 208 01	1	Body-Oil Relief Valve
16	12 050 01	1	Filter-Oil
17	X-75-10	2	Plug-SH 3/8 NPTF
18	52 099 06	1	Switch-Oil Pressure
19	12 393 01	1	Pump-Oil
20	12 032 04	1	O Ring-Oil Pump Cover
21	12 096 02	1	Cover-Oil Pump

Ref. No.	Part No.	Qty.	Description
22	M-0545016	3	Screw M5x0.8x16
23	12 032 03	1	Seal-Crankshaft
24	24 086 16	11	Screw M8x1.25x45
25	24 086 17	11	Screw M8x1.25x45
26	12 199 21	1	Pan-Oil
*	52 518 21	1	Lead-Oil Switch w/Tabs

† Included in a service kit or in an assembly

* Not illustrated

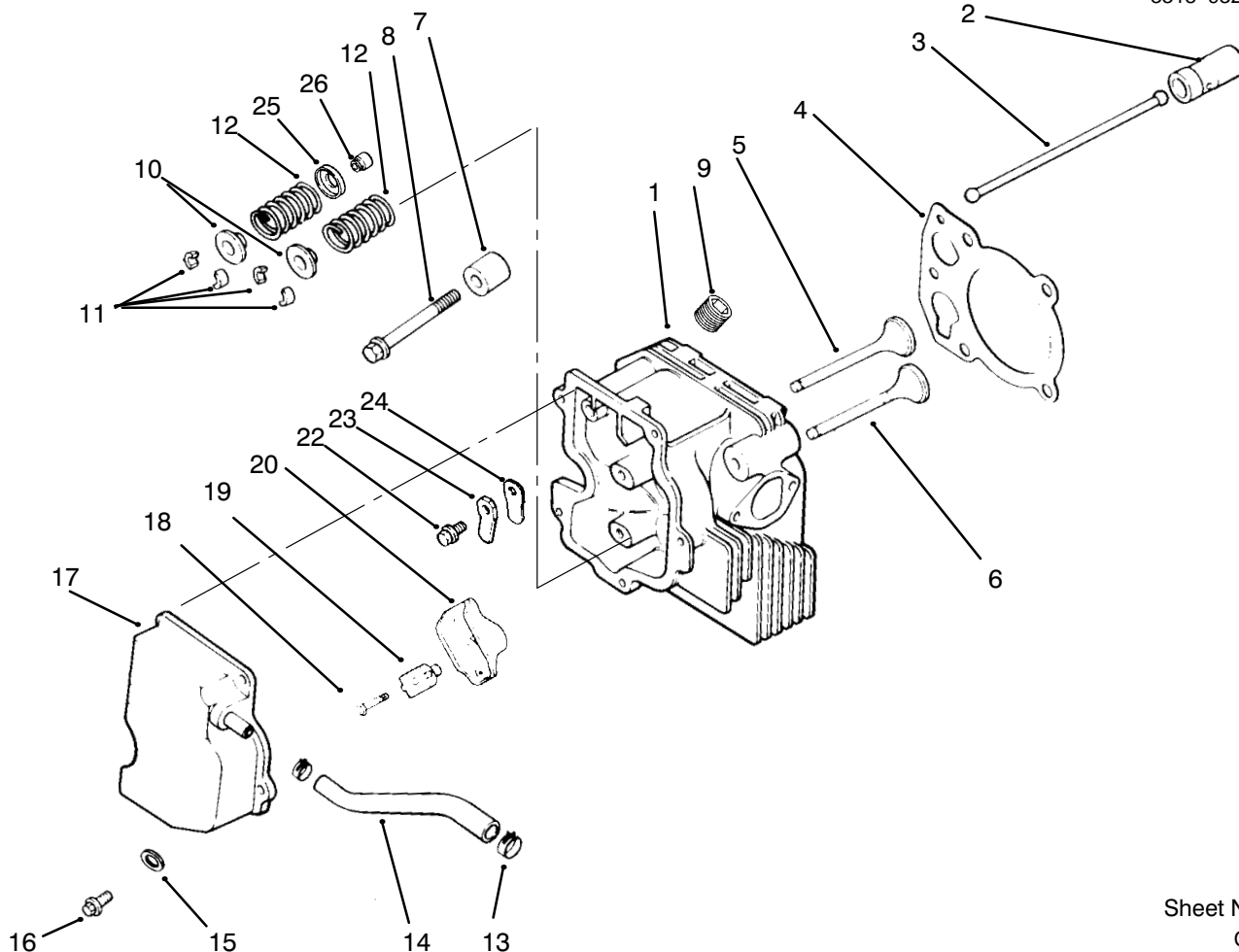

Sheet No.: 104
C-1951

Cylinder Head / Valve / Breather

Ref. No.	Part No.	Qty.	Description
1	12 318 15	1	Cylinder Head
2	12 351 02	1	Lifter-Valve
3	12 411 01	2	Rod-Push
4	12 041 10	1	Gasket-Cylinder Head
5	12 017 01	1	Valve-Intake STD
5	12 017 02	1	Valve-Intake .25
6	12 016 01	1	Valve-Exhaust STD
6	12 016 02	1	Valve-Exhaust .25
7	12 112 13	1	Spacer-Head Bolt Exhaust
8	12 086 15	5	Screw M10x1.5x80
9	X-75-23	1	Plug
10	12 173 01	2	Cap-Valve Spring
11	12 755 03	2	Kit-Retainer
12	12 089 01	2	Spring-Valve
13	X-426-9	2	Clamp-Hose
14	12 326 03	1	Hose-Breather
15	12 468 05	1	Washer-Flat
16	M-0645020	5	Screw-HH M6x1.0x20
17	12 096 07	1	Cover-Valve w/Nipple
18	M-0640034	2	Screw M6x1.0x34
19	12 599 03	2	Pivot-Rocker Arm
20	25 186 01	2	Arm-Rocker
22	M-0545010	1	Screw M5x0.8x10
23	12 018 01	1	Retainer-Breather Reed

Ref. No.	Part No.	Qty.	Description
24	24 402 02	1	Reed-Breather
25	235011	2	Retainer-Spring
26	24 032 05	2	Seal-Valve Stem
*	12 755 63	1	Kit-Cylinder Head (Incl. 3-12,17-20 25 & 26)

* Not illustrated

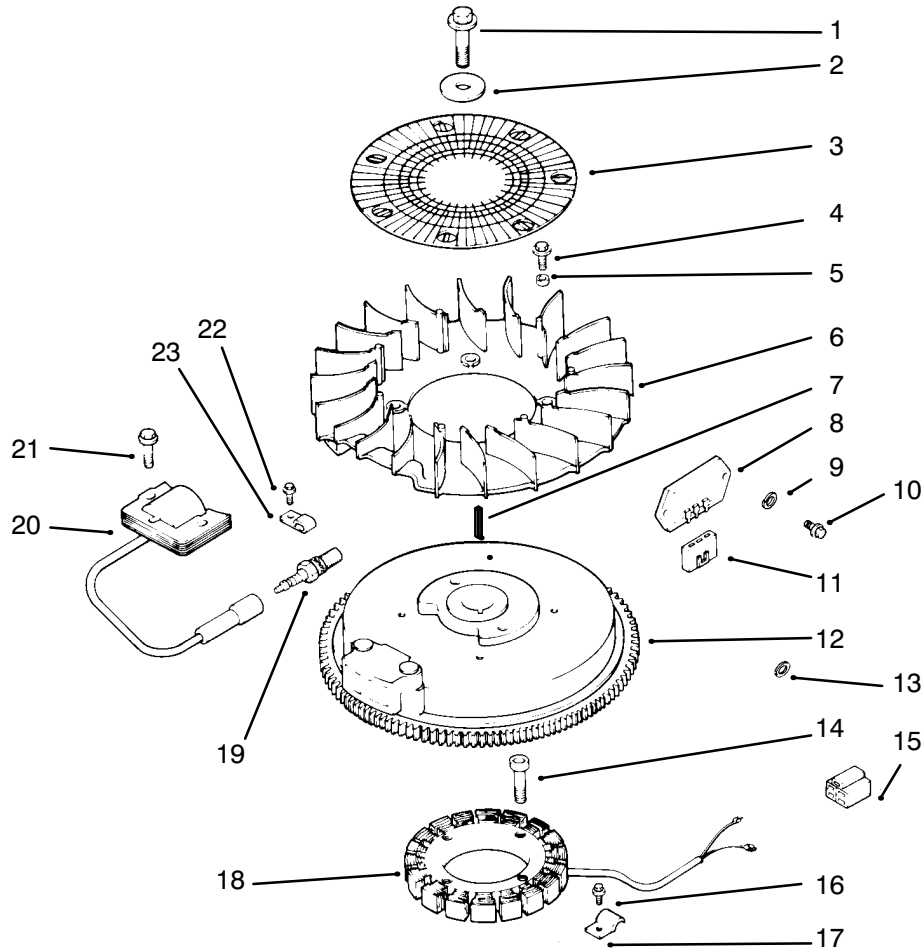

Sheet No.: 105
C-1952

Ignition / Electrical

Ref. No.	Part No.	Qty.	Description
1	12 086 14	1	Screw-Flywheel Mounting
2	12 468 03	1	Washer-Flywheel Screw
3	24 162 03	1	Screen-Grass
4	M-0639016	4	Screw M6x1.0x16
5	12 112 01	4	Spacer-Fan
6	12 157 02	1	Fan
7	X-42-15	1	Key
8	41 403 09	1	Rectifier-Regulator
9	X-22-11	1	Washer-Lock
10	M-0639016	2	Screw M6x1.0x16
11	236602	1	Connector-Regulator
12	12 025 15	1	Flywheel ASM
13	X-25-5	1	Washer-Flat
14	M-0548025	4	Screw M5x0.8x25
15	48 155 01	1	Connector-5 Contact
16	M-0545010	1	Screw M5x0.8x10
17	12 154 02	1	Clip-Stator Harness
18	24 085 01	1	Stator-15 Amp
19	12 132 02	1	Spark Plug
20	12 584 01	1	Module-Ignition
21	M-0545020	2	Screw M5x0.8x20
22	M-0545010	1	Screw M5x0.8x10
23	X-728-1	1	Clip-Kill Lead
*	12 518 01	1	Lead-White

Ref. No.	Part No.	Qty.	Description
*	25 518 05	1	Lead-Black
*	25 518 29	1	Lead-Black

* Not illustrated

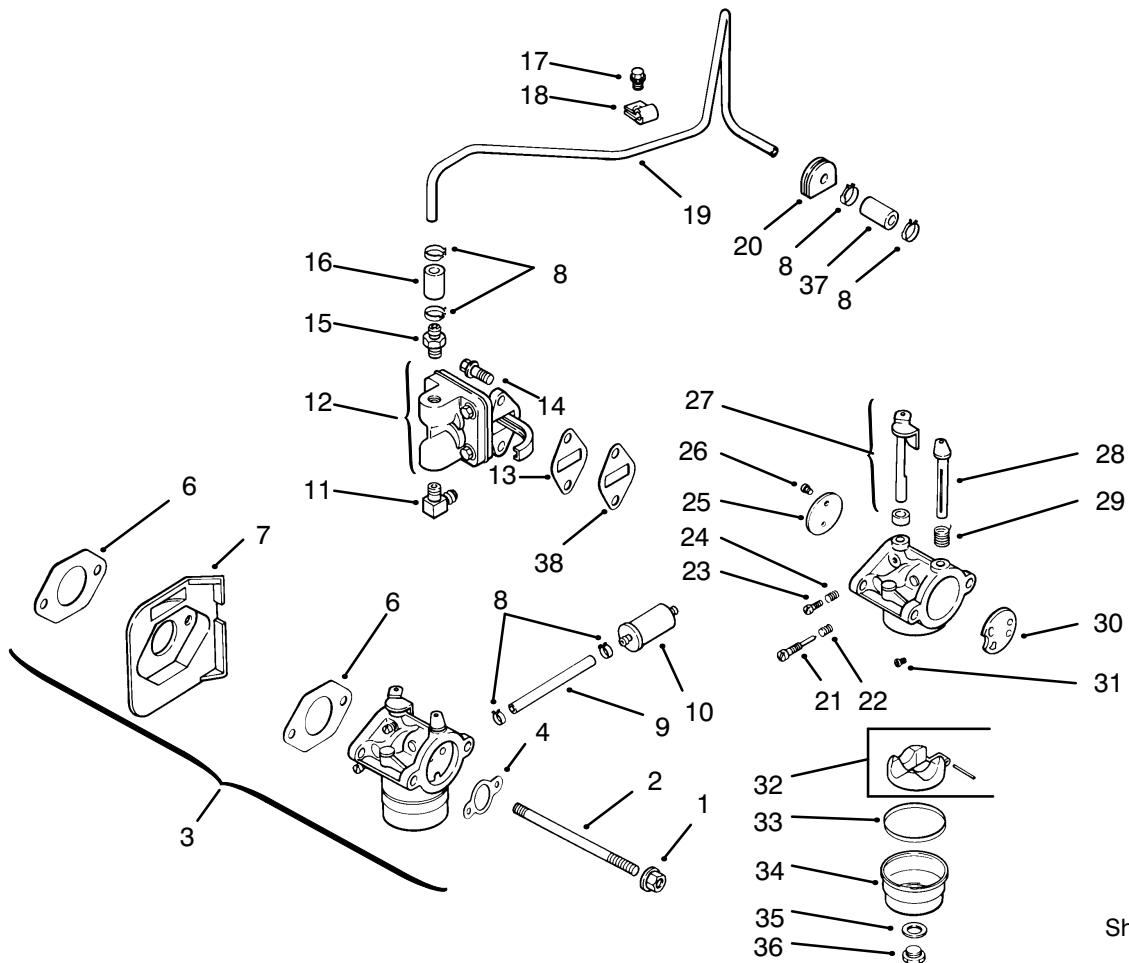

Sheet No.: 108
C-

Fuel System

Ref. No.	Part No.	Qty.	Description
1	M-0641060	2	Nut M6x1.0
2	M-0629122	2	Stud M6x1.0x110
3	12 853 57	1	Kit-Carburetor w/Gasket Incl 4-6
†4	12 041 02	1	Gasket-Air Cleaner
†5	12 053 57	1	Carurator ASM Incl 21-36
†6	12 041 01	2	Gasket-Carburetor
7	12 265 04	1	Deflector-Heat
8	X-426-9	1	Clamp-Hose
9	12 353 10	1	Line-Fuel
10	25 050 02	1	Filter-Fuel
11	25 155 02	1	Connector-90°
12	12 559 01	1	Kit-Pump INC 13-14
†13	25 041 09	1	Gasket-Fuel Pump
†14	M-0645020	2	Screw-HH M6x1.0x20
15	X-380-1	1	Connector-Straight
16	12 353 01	1	Line-Fuel 1.25 Inch
17	M-0545010	1	Screw M5x0.8x10
18	12 154 01	1	Clamp-Fuel Line
19	12 123 19	1	Line-Fuel
20	12 313 01	1	Grommet
†21	12 368 05	1	Needle-Idle Fuel Adjust
†22	12 089 09	1	Spring-Idle Fuel

Ref. No.	Part No.	Qty.	Description
†23	12 086 04	1	Screw-Idle Speed Adjust
†24	12 089 09	1	Spring-Idle Fuel
†25	12 146 03	1	Plate-Throttle
†26	25 086 27	1	Screw-Throttle Plate
†27	12 144 09	1	Shaft-w/Lever & Seal
†28	12 144 08	1	Shaft-Choke
†29	12 089 10	1	Spring-Choke Return
†30	12 146 02	1	Plate-Choke
†31	12 337 03	1	Jet-Main
†32	12 757 02	1	Kit-Float
†33	12 041 05	1	Gasket-Bowl
†34	12 104 01	1	Bowl-Fuel
†35	12 041 06	1	Gasket-Bowl Screw
†36	12 086 05	1	Screw-Fuel Bowl
37	25 353 02	1	Line-Fuel 3"
38	12 112 05	1	Spacer-Fuel Pump
*	12 041 01	1	Gasket-Carburetor
*	12 757 03	1	Kit-Carburetor Repair

† Included in a service kit or in an assembly

* Not illustrated

Electric Schematic Single Cylinder Gear Drive

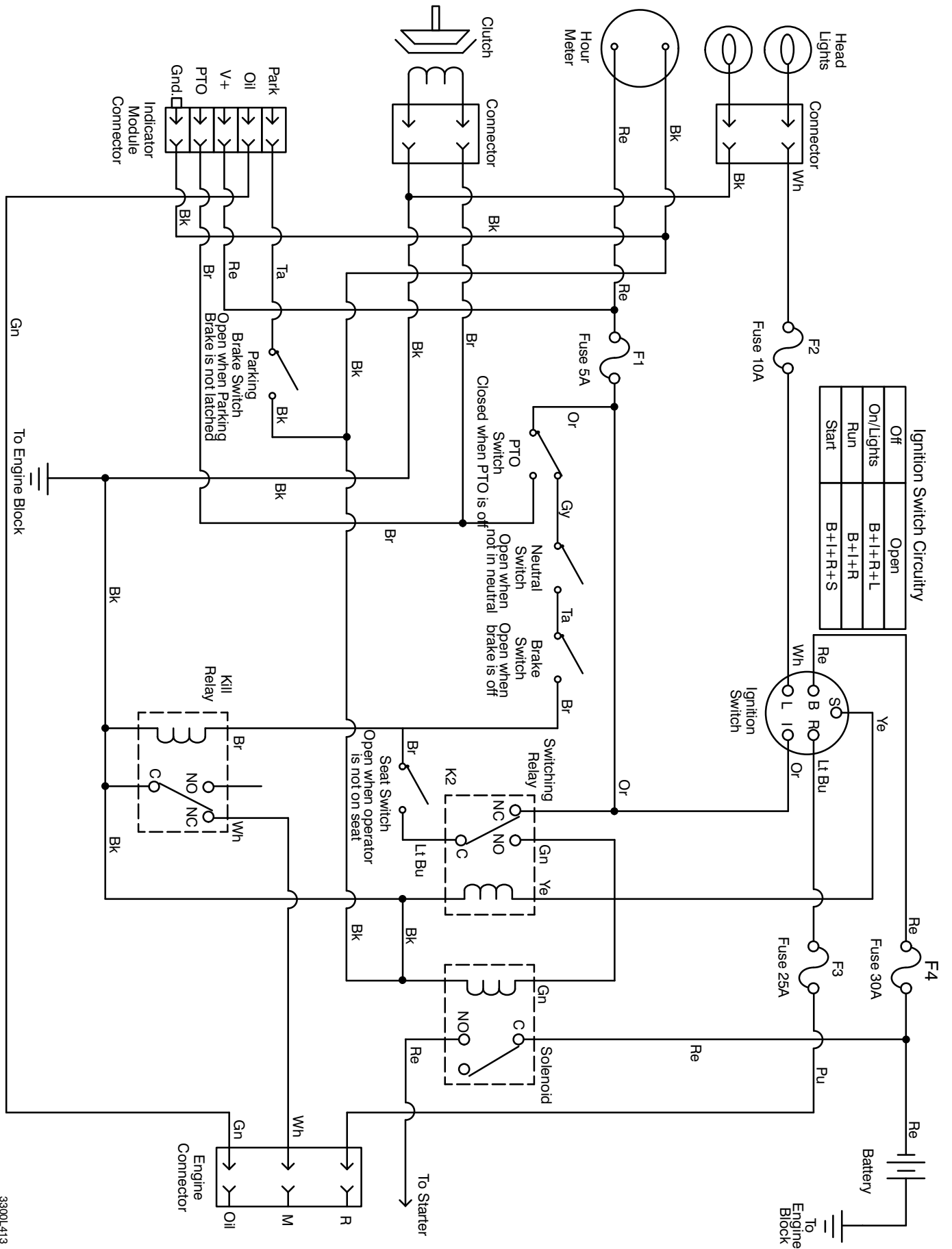

Wire Harness Routing — Single Cylinder Engine

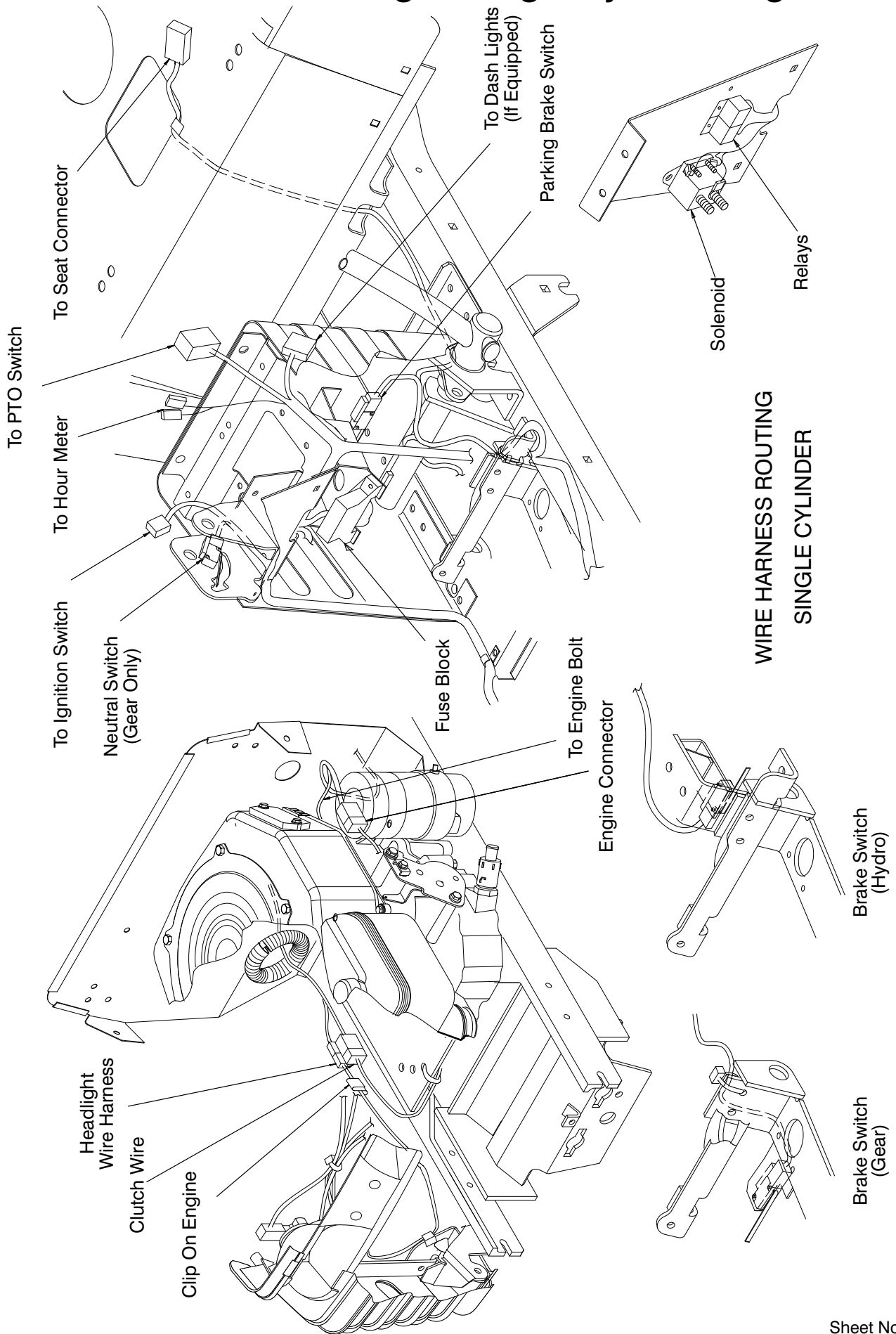

WIRE HARNESS ROUTING SINGLE CYLINDER

Toro Part Number Index

Part No.	Page No.	Ref. No.	Qty.	Description
1278	4	11	2	Washer-Shim
1278	5	17	4	Washer-Shim
2534	12	15	1	Clip-Spring
3624	10	13	1	Spring-Compression
3624	17	5	1	Spring-Compression
5108	5	3:3	2	Valve-Tire Tubeless
5108	19	1:2	2	Valve-Tire Tubeless
5210	5	18	4	Washer-Shim
5618	5	19	1	Ring-Retaining
7896	3	4	1	Washer-Bowed
8130	10	14	1	Retainer-Spring
8830	11	16	1	Retainer-"J"
8870	10	25	1	Trunnion
104047	7	3:1	1	Bushing
104048	7	3:2	1	Assembly-Valve
105503	1	16	2	Bushing
105503	6	14	2	Bushing
105503	17	26	1	Bushing
105842	15	12	1	Battery
106269	10	43	1	Bearing-Flange
106288	8	16	2	Clamp
106557	6	12	2	Reflector
106948	15	6	1	Tray-Battery
107069	8	20	4	Nut-Retainer
107788	12	16	1	Spring-Extension
108881	4	5	1	Nut-Hex
109189	4	7	1	Bearing-Flange
109500	5	3:6	2	Fitting-Grease
109547	15	8	2	Hook-Battery
109989	6	21	2	Spacer
110391	4	6	1	Bearing-Wheel
110513	5	3:2	4	Bearing-Wheel
110656	17	13	1	Trunnion
111078	15	5	1	Cable-Battery Black
111383	4	8	1	Collar w/Set Screw
111418	4	3	1	Bushing
111418	12	17	1	Bushing
111419	4	1	1	Washer-Bearing
111419	12	22	1	Washer-Bearing
111646	4	9	1	Grip Ring
111712	18	23	1	Washer-Wave
112168	10	16	1	Decal-Lift
112843	13	8	1	Washer-PTO
114064	14	4	2	Bearing-Elec Clutch
114720	15	9	1	Tube-Battery Drain
115230	17	9	1	Switch-Clutch
115593	10	8	1	Knob
116397	2	31	2	Relay
116744	19	1:3	2	Tire
117127	5	3:4	2	Tire
117316	15	2	1	Rod-Battery Hold Down
120930	15	10:1	1	Fuse Holder
147665	12	25	2	Screw
147665	17	31	2	Screw
607978	12	10	1	Pulley-Idler
609900	8	9	2	Nut-Speed
700806	6	18	2	Knob
700919	2	15	1	Nut
701178	6	10	2	Cap-Protector
702366	1	27	1	Clip-Wire Retainer
702366	8	2	1	Clip-Wire Retainer
702366	13	2	1	Clip-Wire Retainer

*Not Illustrated

Toro Part Number Index (cont.)

Part No.	Page No.	Ref. No.	Qty.	Description
909543	16	4	2	Screw-Set
933141	10	7	1	Pin-Spirol
933148	10	12	1	Pin-Spirol
933270	5	5	2	Pin-Roll
937225	16	6	1	Key
9114466	13	9	1	Screw HH
9150026	5	8	4	Nut-Lock
9202324	5	16	2	Washer-10 GA
9267154	5	10	1	Screw
5-1336	19	5	2	Key
7-5461	17	17	1	Spacer-Transmission
24-7924	9	19	2	Cover-Drive Shaft
28-2480	5	20	2	Washer-Flat
28-8080	15	15	1	Boot-Battery Terminal
38-1420	6	2	1	Switch-Seat
46-8093	1	31	2	Screw-TAP
46-8093	9	22	2	Screw-TAP
48-7730	3	20	2	Screw-HH
48-7730	13	13	4	Screw-HH
61-9780	5	1	2	Hubcap
62-7770	2	14	1	Key-Ignition
66-0120	2	10	2	Knob
76-1340	8	27	1	Decal-USA
78-1221	19	1:1	2	Wheel
78-1940-01	5	12	1	Arm-Front Spindle RH
78-1950-01	5	6	1	Arm-Front Spindle LH
78-2140	10	41	1	Trunnion
78-2431	10	29	1	Rod
78-2491-03	11	15	1	Stop-PTO
78-2601-01	5	13	2	Spindle
78-2610	4	2	1	Gear-Sector
78-2920	5	7:2	1	Joint-Ball
78-2920	5	9:2	1	Joint-Ball
78-5801	5	7:3	1	Joint-Ball RH w/ Jam Nut
78-5811	5	9:3	1	Joint-Ball LH
78-6771	12	21	1	Arm-Idler
78-6810-03	10	35	1	Plate
78-6820-03	15	7	1	Plate-Battery
78-7360	10	33	1	Rod
78-7390	10	28	1	Link
78-7960-01	5	4	1	Axle-Front
78-8180-03	18	20	1	Pedal-Clutch
78-9150-03	4	4	1	Plate
78-9740	10	9	1	Decal-HOC Knob
79-0390	12	20	1	Guide-Belt
79-0390	13	10	1	Guide-Belt
79-0400	12	27	1	Guide-Belt
79-0950-03	6	17	1	Bracket-Pivot RH
79-0970-03	6	15	1	Bracket-Pivot LH
79-1250	10	27	2	Pin
79-3401-03	10	24	1	Gage Shaft
79-7530	12	14	1	Spring-Extension
83-2720	19	6	10	Bolt-Lug
83-6620	9	13	1	Decal-Instruction
88-3870	3	6:1	1	Cover-Steering Wheel
88-3950	6	1	1	Seat
88-3970	1	28	1	Reflector-Lamp
88-3980	7	2	1	Gas Cap ASM
88-4320	1	29	1	Harness-Wire
88-9930	10	2	1	Switch-Micro
88-9932	12	23	1	Switch - Micro
92-3014	14	1	3	Nut & Spring Asm

*Not Illustrated

Toro Part Number Index (cont.)

Part No.	Page No.	Ref. No.	Qty.	Description
92-3016	14	3	1	Field ASM w/Bearing
92-6656	1	23	1	Lens-Headlight
92-6670	12	34	1	Bracket-Clutch
92-6671	12	35	1	Bracket-Brake
92-6674-03	11	7	1	Support-Fender
92-6680	2	8	1	Boot-Steering
92-6689	8	21	1	Mat-Foot RH
92-6690	8	18	1	Mat-Foot LH
92-6702	4	10	1	Shaft-Steering Lower
92-6705	2	26	1	Lens-Dash
92-6710	10	11	1	Grip-Handle
92-6711	10	10	1	Tip-Rod
92-6716	13	20	1	Gasket-Exhaust
92-6717	3	18	1	U-Joint-Steering
92-6720	2	18	1	Decal-Choke/PTO
92-6721	2	13	1	Decal-Throttle/Ignition
92-6722	2	12	1	Decal-Shift
92-6725	8	23	1	Decal-HOC
92-6727	8	5	1	Decal-Fuel Level
92-6728	1	12	1	Decal-Hood LH
92-6729	1	13	1	Decal-Hood RH
92-6730	8	3	1	Decal-Rear Fender
92-6732	2	28	1	Housing-Indicator Light
92-6744-01	8	19	1	Footrest-RH
92-6745-01	8	13	1	Footrest-LH
92-6750	6	3	2	Spacer-Nylon
92-6754	7	5	1	Hose-Fuel Line
92-6761	16	7	1	Transaxle-Peerless 820
92-6769	16	3	2	U-Bolt
92-6776	3	13	1	Bracket-Detent
92-6777-03	3	1	1	Bracket-Support
92-6778-03	9	9	1	Support-Column
92-6780	13	18	2	Nut-HHF
92-6781	2	24	1	Control-Choke
92-6782	2	22	1	Control-Throttle
92-6785	2	17	1	Switch-Ignition
92-6794	10	4	1	Wedge-HOC Adjust
92-6795-01	8	28	1	Fender
92-6797	2	19	1	Cover-Slot LH
92-6798	3	11	1	Cap-Rod
92-6855-03	10	32	1	Arm
92-6859-03	9	6	1	Support-Dash
92-6860	9	8	4	Nut-Retainer
92-6867-01	13	17	1	Shield-Muffler
92-6868-03	11	4	1	Bracket-Idler
92-6875	17	11	3	Bearing-Shift Link
92-6877	13	5	1	Valve-Oil Drain
92-6878-03	13	21	1	Baffle-Muffler
92-6883	5	7	1	Steering Link RH
92-6884	5	9	1	Steering Link LH
92-6886	17	18	1	Arm-Shift
92-6887	16	5	1	Pulley
92-6889-03	16	8	1	Strap-Torque LH
92-6890-03	16	12	1	Strap-Torque RH
92-6891-03	12	7	1	Bracket-Idler Spring
92-6894-03	12	12	1	Bracket-Idler Rear
92-6896	17	20	1	Rod-Shift Transaxle
92-6907	15	10	1	Harness-Wire
92-6914-03	1	32	1	Baffle-Hood Upper
92-6917-03	1	10	1	Bracket-Hinge RH
92-6918-03	1	9	1	Bracket-Hinge LH
92-6919	17	4	1	Pivot-Shift

*Not Illustrated

Toro Part Number Index (cont.)

Part No.	Page No.	Ref. No.	Qty.	Description
92-6920	17	34	1	Rod-Shift
92-6921	17	2	1	Bracket-Shaft
92-6924	18	19	1	Rod-Clutch
92-6926-03	17	12	1	Tube-Linkage
92-6929-03	18	7	1	Bracket-Parking Brake
92-6931	18	9	1	Lever-Parking Brake
92-6936-03	9	15	1	Cover-Side LH
92-6937-03	9	2	1	Cover-Side RH
92-6955	16	2	1	Belt
92-6960	9	24	2	Latch-Hood
92-6964-03	11	6	1	Bracket-HOC
92-6965	10	6	1	Rod-HOC
92-6971	3	5	1	Lever-Tilt
92-6972-03	6	5	1	Support-Seat
92-6975	2	25	1	Decal-Dash Lens
92-6977-03	10	17	1	Rod-Lift Lever
92-6978	10	38	1	Rod-HOC Indicator
92-6979	10	42	1	Plate-HOC Gage
92-6986	6	8	2	Bolt-Shoulder
92-6987	1	24	1	Decal-Horsehead
92-6989	2	1	1	Cable-Battery Red
92-6990	15	1	1	Cable-Battery Red
92-6992-03	11	12	1	Bracket-Steering
92-6996-03	1	18	1	Hinge-Hood RH
92-6997-03	1	17	1	Hinge-Hood LH
92-6998	3	22	1	Spacer-Yoke
92-6999	3	15	1	Spacer-Yoke
92-7001	12	3	1	Guide-Belt RH
92-7002	12	6	1	Guide-Belt LH
92-7005	17	22	1	Rod
92-7006	1	4	4	Nut
92-7007	10	39	1	Spring-Extension
92-7009	18	10	1	Grip-Parking Brake
92-7019	18	5	1	Rod-Park Brake
92-7020	8	25	4	Screw-TTH
92-7020	9	1	9	Screw-TTH
92-7048-03	1	21	1	Bracket-Hood Hinge RH
92-7049-03	1	20	1	Bracket-Hood Hinge LH
92-7054	6	7	2	Spring-Compression
92-7057-03	5	11	1	Pin-Front
92-7077	1	3	1	Inlet-Seal Air
92-7101	12	19	1	Pulley-Flat
92-7102	12	26	1	Pulley-Idler
92-7116	18	3	1	Spring-Compression
92-7148	1	6	2	Foam-Sidepanel
92-8747	11	14	2	Decal-Attach A Matic
92-8946	8	26	1	Decal-Danger
92-9845	2	4	1	Solenoid
93-0301	9	12	1	Decal-Slope/Park Brake
93-0320	12	31	1	Pulley-Idler
93-0321	13	6	1	Pulley-Engine
93-0485-03	9	14	1	Hoodstand w/Decals
93-0489-01	8	24	1	Plate-Footrest w/Decal
93-0490	1	2	1	Hood
93-0491	1	7	1	Sidepanel-LH Hood
93-0492	1	8	1	Sidepanel-RH Hood
93-0494	1	22	1	Grille & Screen ASM
93-0503-03	17	30	1	Bracket-Pivot Mount
93-0523-03	10	44	1	Bracket-Pivot Linkage
93-0524	17	25	1	Bracket-Pivot
93-0526-03	12	32	1	Bracket-Micro Switch
93-0547	12	30	1	Guide-Belt

*Not Illustrated

Toro Part Number Index (cont.)

Part No.	Page No.	Ref. No.	Qty.	Description
93-0548	12	37	1	Guide-Belt
93-0549	12	11	1	Guide-Belt
93-1131	9	23	1	Trim-Seal
93-1146	3	3	1	Bushing-Steering
93-1148-03	3	12	1	Column
93-1357	3	14	1	Spring-Extension
93-3141	17	33	1	Decal-Reverse Shift
93-3228-03	18	1	1	Pedal-Brake
93-3658	12	28	1	Spacer
93-3659-03	19	2	2	Hub-Wheel
93-9800	5	3	2	ASM-Wheel & Tire
93-9801	5	3:1	2	ASM-Wheel w/Zerk
93-9998	2	16	1	Switch-PTO
94-1712-03	9	4	1	Panel-Support
94-1717-03	8	6	1	Panel-Rear
94-1723-03	18	14	1	Stop-Brake
94-1729	18	11	1	Rod-Spring
94-1733	18	15	1	Spring-Extension
94-1734	18	12	1	Spring-Compression
94-1749-03	9	18	1	Firewall
94-1862	18	21	2	Spacer
94-1895	2	7	1	Dash-Gear
94-1980	1	1	2	Foam-Hood
94-2514	13	7	1	Clutch-Electric PTO
94-2668	11	10	1	Frame Wa
94-2688	18	17	1	Trunnion
94-2869	6	20	2	Washer-Flat
94-2869	8	12	4	Washer-Flat
94-2874	3	9	1	Shaft-Steer Upper
94-2966	2	9	1	Clip-Boot
94-2970	13	3	1	Decal-Toro Power Plus 15
94-2972	9	16	2	Decal-265-6
94-3500	3	6	1	Steering Wheel-14"
94-3552-03	10	34	1	Lift Arm
94-3761-03	10	15	1	Lift Lever Wa
94-4208	2	27	1	Hourmeter
94-4930	14	2	1	Rotor & Armature ASM
94-4944	10	30	1	Shaft
94-6928	7	3	1	Tank-Gas
94-6961	2	29	3	Screw
95-1663	13	19	1	Muffler
95-3003	10	3	2	Screw
95-3039-03	18	25	1	Brake Arm Wa
95-3041	13	4	1	Engine-Kohler
233-42	17	6	1	Knob
237-141	2	6	1	Grommet
2412-98	7	4	2	Clamp-Hose
256-90	10	31	2	Bushing-Flange
256-219	17	29	2	Bushing
302-5	5	14	2	Fitting-Grease
302-5	18	22	2	Fitting-Grease
302-11	5	15	1	Fitting-Grease
321-4	2	5	2	Screw-HH
321-4	3	2	4	Screw-HH
321-4	8	8	2	Screw-HH
321-4	9	10	4	Screw-HH
321-4	15	3	2	Screw-HH
322-3	1	15	2	Screw-HH
322-3	3	17	1	Screw-HH
322-3	17	7	2	Screw-HH
322-5	6	4	4	Screw-HH
322-5	11	8	1	Screw-HH

*Not Illustrated

Toro Part Number Index (cont.)

Part No.	Page No.	Ref. No.	Qty.	Description
322-5	17	24	1	Screw-HH
322-6	16	1	1	Screw-HH
322-11	18	13	2	Screw-HH
322-17	3	23	1	Screw-HH
323-9	12	8	2	Screw-HH
323-10	12	18	2	Screw-HH
329-23	17	14	1	Screw
3217-9	3	7	1	Nut-HH
3218-2	18	16	2	Nut-Hex Jam
3218-3	19	4	4	Nut-HJ
3229-11	9	5	4	Bolt-CARR
3230-1	1	26	2	Bolt-CARR
3230-2	6	19	4	Screw-CARR
3230-2	8	29	1	Screw-CARR
3230-2	11	3	2	Screw-CARR
3230-20	8	15	4	Bolt-CARR
3230-23	8	22	3	Bolt-CARR
3230-31	8	4	6	Screw-CARR
3231-4	4	12	1	Bolt-CARR
3231-25	10	21	2	Screw-CARR
3231-25	12	2	1	Screw-CARR
3231-25	13	14	2	Screw-CARR
3243-5	19	3	4	Screw-Set
3245-32	4	8:1	1	Screw-Set
3253-3	17	15	1	Washer-Lock
3253-4	3	19	2	Washer-Lock
3253-4	13	12	4	Washer-Lock
3253-5	12	29	1	Washer-Lock
3253-7	3	8	1	Washer-Lock
3256-3	18	26	1	Washer-Flat
3256-22	8	7	2	Washer-Flat
3256-22	18	2	3	Washer-Flat
3256-23	3	16	2	Washer-Flat
3256-23	8	10	2	Washer-Flat
3256-23	11	2	2	Washer-Flat
3256-23	12	4	2	Washer-Flat
3256-23	13	11	1	Washer-Flat
3256-23	16	11	6	Washer-Flat
3256-23	18	8	5	Washer-Flat
3256-24	10	22	2	Washer-Flat
3256-24	12	9	6	Washer-Flat
3256-24	13	15	2	Washer-Flat
3256-24	17	19	2	Washer-Flat
3256-24	18	29	1	Washer-Flat
3256-26	10	20	6	Washer-Flat
3256-28	3	10	1	Washer-Flat
3256-49	6	13	4	Washer-Flat
3256-71	17	21	1	Washer-Flat
3272-2	18	4	2	Pin-Cotter
3272-6	10	18	1	Pin-Cotter
3272-6	17	16	2	Pin-Cotter
3272-6	18	6	5	Pin-Cotter
3272-17	5	2	2	Pin-Cotter
3290-282	6	11	4	Pop Rivet
3290-307	17	23	2	Pin-Cotter
3290-354	10	1	1	Nut-Speed
3290-354	12	33	1	Nut-Speed
3290-354	17	10	1	Nut-Speed
3290-479	8	17	14	Fastener-Panel
3296-8	3	24	4	Nut-Lock
3296-8	9	7	4	Nut-Lock
3296-23	10	26	1	Nut-Lock

*Not Illustrated

Toro Part Number Index (cont.)

Part No.	Page No.	Ref. No.	Qty.	Description
3296-29	1	19	4	Nut-Lock
3296-29	3	21	2	Nut-Lock
3296-29	6	16	6	Nut-Lock
3296-29	8	11	14	Nut-Lock
3296-29	11	1	2	Nut-Lock
3296-29	16	10	6	Nut-Lock
3296-29	17	27	1	Nut-Lock
3296-29	17	28	2	Nut-Lock
3296-29	18	18	2	Nut-Lock
3296-39	10	23	2	Nut-Lock
3296-39	12	13	4	Nut-Lock
3296-39	13	16	2	Nut-Lock
3296-42	2	3	2	Nut-Lock
3296-42	9	11	3	Nut-Lock
3296-58	6	9	2	Nut-Flange
32103-22	9	21	4	Nut-Wing
32103-22	15	4	4	Nut-Wing
32105-15	1	5	12	Screw-HH
32120-47	10	19	5	Ring-Retaining
32121-4	17	32	1	Pin-Roll
32121-25	10	40	1	Pin-Roll
32121-97	17	1	1	Pin-Roll
32121-103	10	37	1	Pin-Spring
32128-10	1	14	8	Nut-Lock HHF
32144-4	7	16	2	Screw-TAP
32144-4	9	20	2	Screw-TAP
32144-4	10	5	1	Screw-TAP
32144-4	12	24	2	Screw-TAP
32144-4	17	3	2	Screw-TAP
32144-8	2	30	2	Screw-PPH
32144-8	9	26	2	Screw-PPH
32144-14	1	11	2	Screw-HWH
32144-14	9	25	2	Screw-HWH
32144-14	10	36	2	Screw-HWH
32144-14	11	5	6	Screw-HWH
32144-14	12	5	5	Screw-HWH
32144-14	13	1	3	Screw-HWH
32144-14	15	11	1	Screw-HWH
32144-32	1	33	2	Screw-Plastic
32144-32	2	23	4	Screw-Plastic
32144-70	10	45	2	Screw-TAP
32144-70	12	1	3	Screw-TAP
32144-70	16	9	4	Screw-TAP
32149-2	2	2	2	Nut-Hex Lock
32149-2	9	3	2	Nut-Hex Lock

*Not Illustrated

