



**Wheel Horse[®]
Lawn And Garden Tractor
38" Side Discharge
& Recycler[®]
Cutting Units**

**Model No. 78216-7900001 & Up
Model No. 78226-7900001 & Up**

Parts Catalog

ORDERING REPLACEMENT PARTS

To order replacement parts, please supply: the part number, the quantity, and the description of each part desired.

Contents

Description	Page	Description	Page
Blade, Spindle, Belt And Idler Pulley	1	Gage Wheels, Deck And Side Discharge Deflector . . .	3
Gage Wheels, Deck And Side Discharge Deflector . . .	2	Note:	

Part Description Abbreviations

Part descriptions in this catalog may include the following abbreviations.

Abbreviation	Meaning	Abbreviation	Meaning
AR	as required	HWHTF	hex washer head thread forming
ASM	assembly	INC	incorporated
CARR	carriage	LH	left hand
DEG	degrees	PH	pan head
FH	flat head	PPH	Phillips pan head
GA	gauge	PTO	power take off
HF	hex flange	RH	right hand
HFV	hex flange washer	SFH	slotted fillister head
HH	hex head	SH	square head
HHF	hex head flange	SHWH	slotted hex washer head
HHST	hex head self tapping	SPH	slotted pan head
HJ	hex jam	STD	standard
HOC	height-of-cut	TAP	self tapping
HS	hex socket	TH	truss head
HSBH	hex socket button head	TTH	Torx truss head
HSFH	hex socket flat head	WH	wing head
HSH	hex socket head		
HWH	hex washer head		

Important Format Explanations

This catalog uses special formats to convey information in illustrations and parts lists. Specifically, one format is used in conjunction with service assemblies and another with quantities associated with reference numbers.

Service Assemblies

Parts within service assemblies have reference numbers in the form *X:Y*. *X* is the reference number of the service assembly and *Y* is a sequential number unique to each part within the service assembly.

For example, a wheel assembly might be identified by reference number 6, the tire by 6:1, the valve by 6:2, and the wheel by 6:3. When you order the assembly identified by reference number 6, you receive all parts identified by reference numbers 6:1, 6:2, and 6:3. However, you may also order any part individually.

Reference numbers of this type appear in part lists and as callouts in illustrations.

Reference Numbers with Quantities

Illustrations may have a quantity in parentheses next to a reference number, in the form *X (Y)*. *X* is the reference number. *Y* in parentheses is the quantity of the part identified by the reference number.

For example, the illustration callout 4 (2) indicates that two parts are used in that instance.

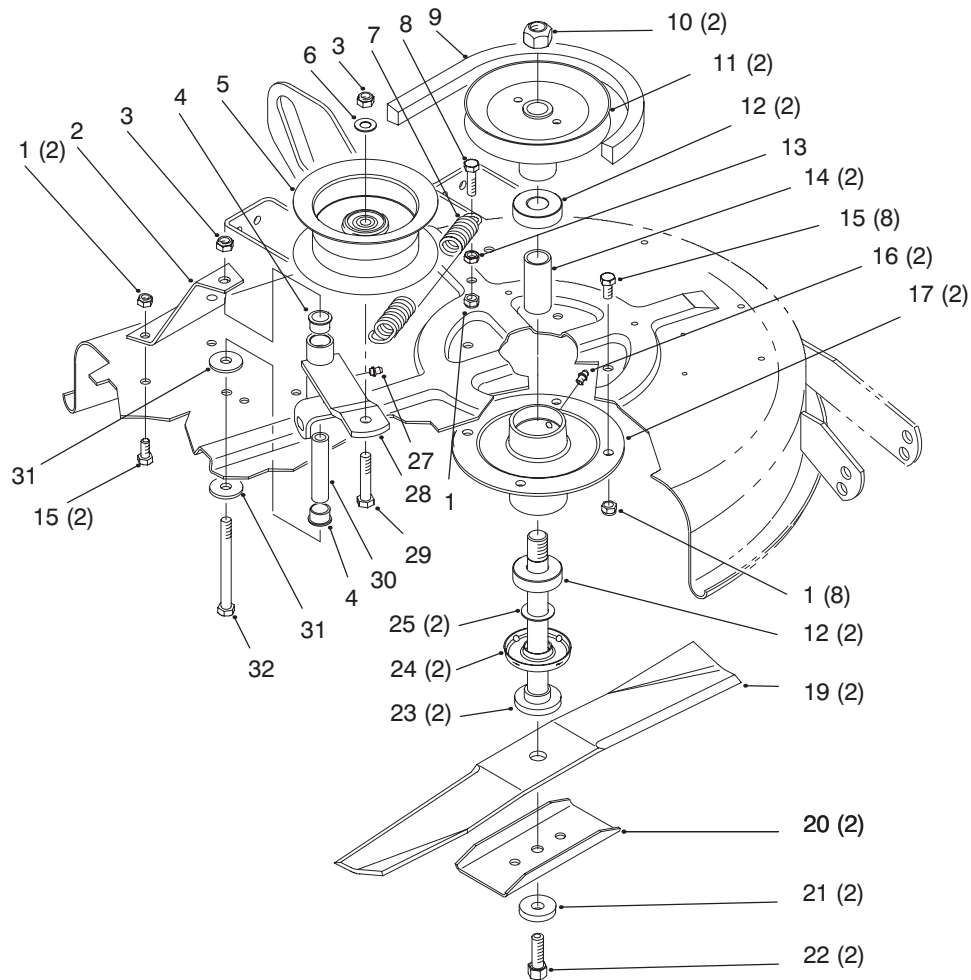

Sheet No.: 2

Blade, Spindle, Belt And Idler Pulley

Ref. No.	Part No.	Description	No. Used	Ref. No.	Part No.	Description	No. Used
1	3296-29	Nut-Lock	11	19	14-7799	Kit-Blade (Model No. 78226 Only)	2
2	78-8091-03	Brace	1	20	80-0510-03	Blade-Stiffener (Model No. 78226)	2
3	3296-39	Nut-Lock	2	21	112843	Washer (Model No. 78216)	2
4	109859	Bushing	2	21	3290-465	Washer (Model No. 78226)	2
5	92-7082	Pulley-Idler	1	22	26-0671	Bolt-Blade	2
6	3256-24	Washer-Flat	1	23	80-4351	Shaft-Spindle	2
7	78-6210	Spring-Extension	1	24	80-4370	Shield-Bearing	2
8	322-6	Screw-Hex. Hd.	1	25	80-4390	Spacer-Hardened	2
9	79-5980	"V" Belt	1	27	302-5	Fitting-Grease	1
10	3219-7	Nut-Hex	2	28	94-9795	Arm (Incl. Ref. #27)	1
11	92-7081	Pulley	2	29	323-10	Screw-Hex. Hd.	1
12	79-1090	Bearing-Ball	4	30	109950	Spacer	1
13	3217-6	Nut-Hex	1	31	2844	Washer-Flat	2
14	79-2780	Spacer	2	32	323-16	Screw-Hex. Hd.	1
15	322-3	Screw-Hex. Hd.	10				
16	302-16	Fitting-Grease	2				
17	79-1050-03	Housing-Spindle	2				
19	57-4700	Blade (Model No. 78216)	2				

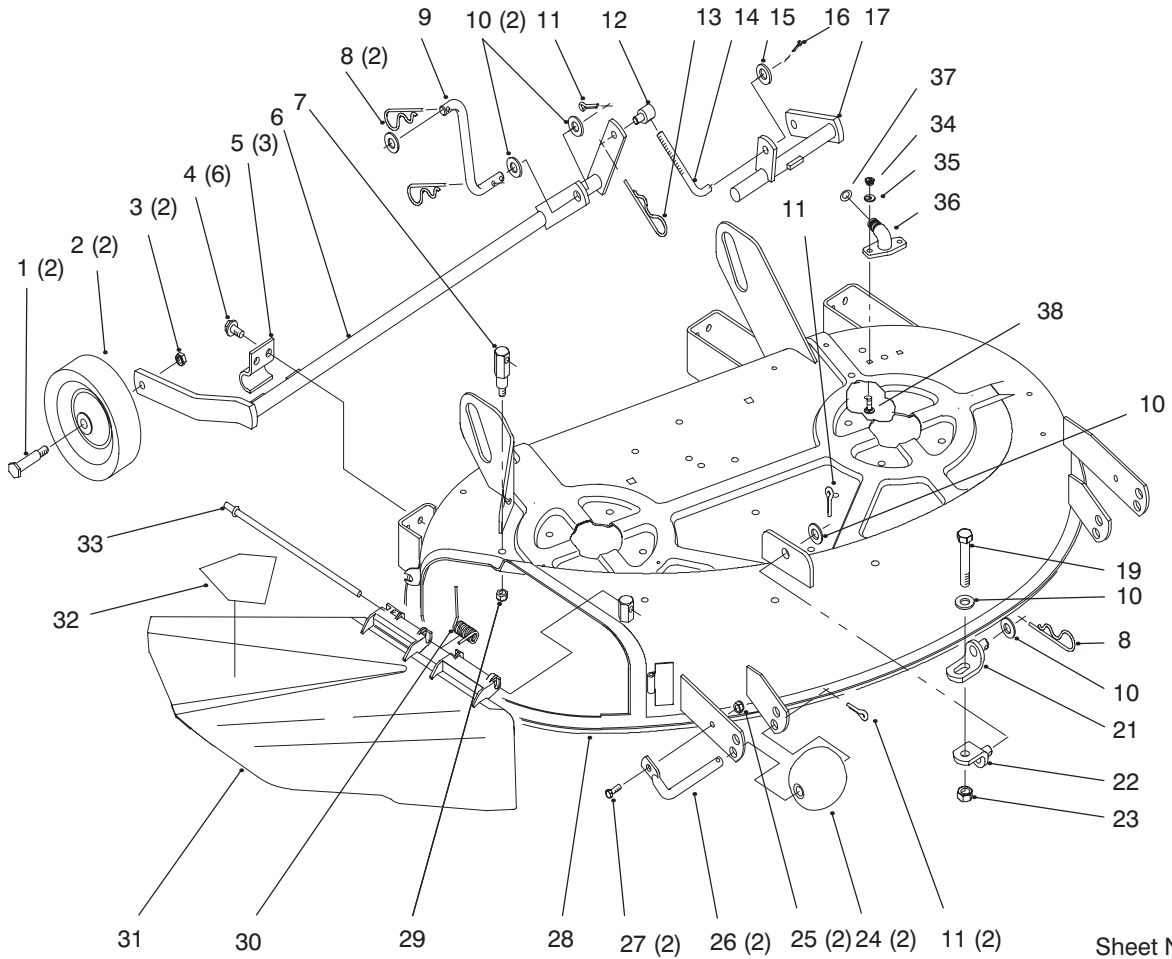

Gage Wheels, Deck And Side Discharge Deflector

Ref. No.	Part No.	Description	No. Used
1	5188	Screw-Hex. Soc. Hd.	2
2	110506	Wheel-Gage	2
3	32146-2	Nut-Lock	2
4	9267154	Screw	6
5	78-6400-03	Clamp	3
6	78-8011-03	Shaft	1
7	92-7063	Pivot Post-Rear	1
8	9335064	Hairpin-Cotter	3
9	78-8071	Link-Rear	1
10	3256-26	Washer-Flat	6
11	3272-21	Pin-Cotter	4
12	110656	Trunnion	1
13	9335044	Hairpin	1
14	121010	Rod-Lift	1
15	3256-24	Washer-Flat	1
16	3272-6	Pin-Cotter	1
17	92-7073-03	Shaft	1
19	325-13	Screw-Hex. Hd.	1

Ref. No.	Part No.	Description	No. Used
21	86-9240	Bracket	1
22	86-9250	Bracket	1
23	3218-5	Nut-Jam	1
24	29-4820	Roller	2
25	3296-42	Nut-Lock	2
26	118960	Shaft-Roller	2
27	321-4	Screw-Hex. Hd.	2
28	92-6834	Asm-Deck	1
29	3296-39	Nut-Lock	1
30	57-6950	Spring-Torsion Deflector	1
31	93-0317	Deflector Asm 38"	1
32	93-1122	Decal-Danger	1
33	57-4380	Rod- Hinge Deflector	1
34	3296-16	Nut - Lock	2
35	3256-1	Washer - Flat	2
36	95-2747	Fitting - Wash out	1
37	46-6290	O-Ring	1
38	3229-1	Bolt - Carriage	2

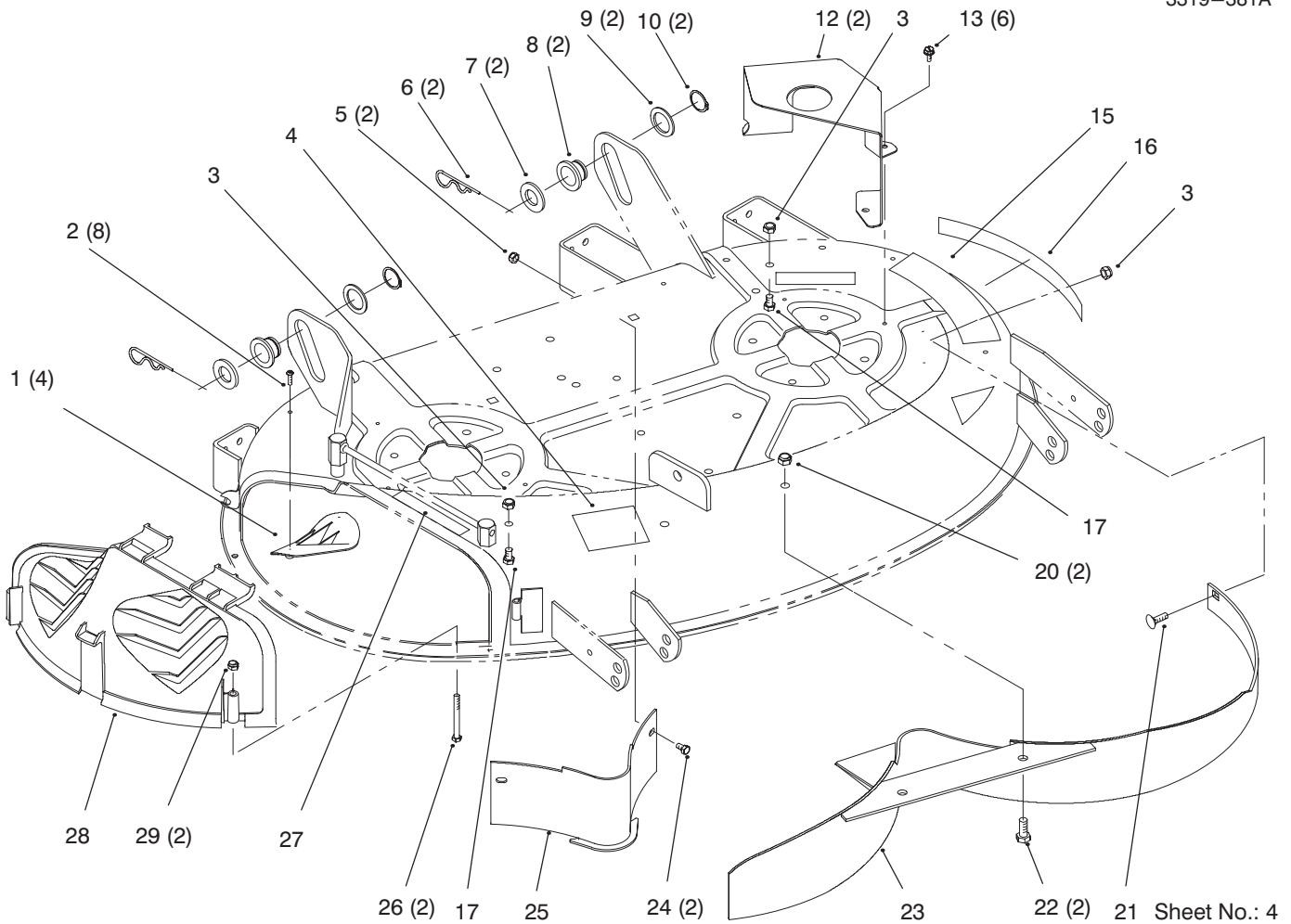

Gage Wheels, Deck And Side Discharge Deflector

Ref. No.	Part No.	Description	No. Used
1	76-2160	Plate-Kicker (Model No. 78226 Only)	4
2	32144-111	Screw-Pan Hd.	8
3	3296-29	Nut-Lock	3
4	117137	Decal-Routing	1
5	3296-42	Nut-Lock (Model No. 78226 Only)	2
6	9335074	Cotter-Hairpin	2
7	3256-28	Washer-Flat	2
8	78-7340	Roller-Lift	2
9	9202394	Washer	2
10	32151-29	Ring-Ext Snap	2
12	78-6840-03	Cover-Belt	2
13	32104-76	Screw-Self TAP	6
15	93-7110	Decal-Danger (Model No. 78216)	1
15	92-7111	Decal-Danger (Model No. 78226)	1
16	92-9520	Decal-Deck	

Ref. No.	Part No.	Description	No. Used
17	322-1	(Model No. 78226) Screw-Hex. Hd.	1
20	3296-39	Nut-Lock	2
21	3230-18	Screw-Hex. Hd. (Model No. 78216 Only)	1
21	3230-1	Screw-CARR (Model No. 78226 Only)	1
22	323-5	Screw-Hex. Hd. (Model No. 78226 Only)	2
23	79-1600-03	Baffle (Model No. 78226 Only)	1
24	321-4	Screw-Hex. Hd.	2
25	79-1640-03	Baffle (Model No. 78226 Only)	1
26	321-15	Screw-Hex. Hd.	2
27	92-7109	Decal-Danger	1
28	88-4430	Recycler Cover (Model No. 78226 Only)	1
29	32111-7	Nut-Cap	2

TORO PART NUMBER INDEX

Part No.	Description	Pg. No.	Ref. No.	Qty.	Part No.	Description	Pg. No.	Ref. No.	Qty.
2844	Washer-Flat	1	31	2	92-7082	Pulley-Idler	1	5	1
5188	Screw-Hex. Soc. Hd.	2	1	2	92-7109	Decal-Danger	3	27	1
109859	Bushing	1	4	2	92-7110	Decal-Danger	3	15	1
109950	Spacer	1	30	1	92-7111	Decal-Danger	3	15	1
110506	Wheel-Gage	2	2	2	92-9520	Decal-Deck	3	16	1
110656	Trunnion	2	12	1	93-0317	Deflector Asm 38"	2	31	1
112843	Washer (Model No. 78216)	1	21	2	93-1122	Decal-Danger	2	32	1
117137	Decal-Routing	3	4	1	93-7110	Decal-Danger	3	15	1
118960	Shaft-Roller	2	26	2	94-9795	Arm	1	28	1
121010	Rod-Lift	2	14	1	95-2747	Fitting-Washout	2	36	1
9202394	Washer	3	9	2	302-16	Fitting-Grease	1	16	2
9267154	Screw	2	4	6	302-5	Fitting-Grease	1	27	1
9335044	Hairpin	2	13	1	321-4	Screw-Hex. Hd.	3	24	2
9335064	Hairpin-Cotter	2	8	3	321-4	Screw-Hex. Hd.	2	27	2
9335074	Cotter-Hairpin	3	6	2	321-15	Screw-Hex. Hd.	3	26	2
14-7799	Kit-Blade	1	19	2	322-1	Screw-Hex. Hd.	3	17	2
26-0671	Bolt-Blade	1	22	2	322-3	Screw-Hex. Hd.	1	15	10
29-4820	Roller	2	24	2	322-6	Screw-Hex. Hd.	1	8	1
46-6290	O-Ring	2	37	1	323-5	Screw-Hex. Hd.	3	22	2
57-4380	Rod- Hinge Deflector	2	33	1	323-10	Screw-Hex. Hd.	1	29	1
57-4700	Blade (Model No. 78216)	1	19	2	323-16	Screw-Hex. Hd.	1	32	1
57-6950	Spring-Torsion Deflector	2	30	1	325-13	Screw-Hex. Hd.	2	19	1
76-2160	Plate-Kicker	3	1	4	3217-6	Nut-Hex	1	13	1
78-6210	Spring-Extension	1	7	1	3218-5	Nut-Jam	2	23	1
78-6400-03	Clamp	2	5	3	3219-7	Nut-Hex	1	10	2
78-6840-03	Cover-Belt	3	12	2	3229-1	Bolt-Carriage	2	38	2
78-7340	Roller-Lift	3	8	2	3230-1	Screw-CARR	3	21	1
78-8011-03	Shaft	2	6	1	3230-18	Screw-Hex. Hd.	3	21	1
78-8071	Link-Rear	2	9	1	3256-24	Washer-Flat	1	6	1
78-8091-03	Brace	1	2	1	3256-24	Washer-Flat	2	15	1
79-1050-03	Housing-Spindle	1	17	2	3256-26	Washer-Flat	2	10	5
79-1090	Bearing-Ball	1	12	4	3256-28	Washer-Flat	3	7	2
79-1600-03	Baffle	3	23	1	3272-6	Pin-Cotter	2	16	1
79-1640-03	Baffle	3	25	1	3272-21	Pin-Cotter	2	11	4
79-2780	Spacer	1	14	2	3290-465	Washer (Model No. 78226)	1	21	2
79-5980	V Belt	1	9	1	3292-16	Nut-Lock	2	34	2
80-0510-03	Blade-Stiffener	1	20	2	3296-29	Nut-Lock	1	1	11
80-4351	Shaft-Spindle	1	23	2	3296-29	Nut-Lock	3	3	3
80-4370	Shield-Bearing	1	24	2	3296-39	Nut-Lock	1	3	2
80-4390	Spacer-Hardened	1	25	2	3296-39	Nut-Lock	3	20	2
86-9240	Bracket	2	21	1	3296-39	Nut-Lock	2	29	1
86-9250	Bracket	2	22	1	3296-42	Nut-Lock	3	5	4
88-4430	Recycler Cover	3	28	1	3296-42	Nut-Lock	2	25	2
92-6834-01	Asm-Decal	2	28	1	32104-76	Screw-Self TAP	3	13	6
92-7063	Pivot Post-Rear	2	7	1	32144-111	Screw-Pan Hd.	3	2	8
92-7073-03	Shaft	2	17	1	32146-2	Nut-Lock	2	3	2
92-7081	Pulley	1	11	2	32151-29	Ring-Ext Snap	3	10	2

*Not Illustrated

