



**Count on it.**

**Operator's Manual**

**21in Heavy-Duty Recycler®/Rear  
Bagger Lawn Mower**

Model No. 22196—Serial No. 311000001 and Up

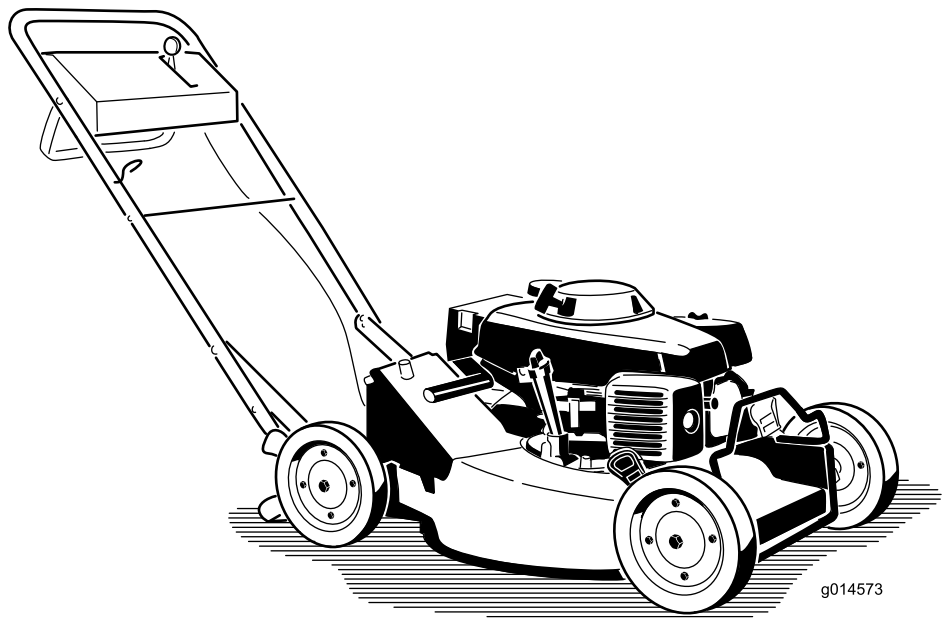

g014573

## WARNING

### CALIFORNIA Proposition 65 Warning

The engine exhaust from this product contains chemicals known to the State of California to cause cancer, birth defects, or other reproductive harm.

## WARNING

### CALIFORNIA Proposition 65 Warning

The engine exhaust from this product contains chemicals known to the State of California to cause cancer, birth defects, or other reproductive harm.

**Important:** This engine is not equipped with a spark arrester muffler. It is a violation of California Public Resource Code Section 4442 to use or operate the engine on any forest-covered, brush-covered, or grass-covered land. Other states or federal areas may have similar laws.

This spark ignition system complies with Canadian ICES-002.

The enclosed *Engine Owner's Manual* is supplied for information regarding the US Environmental Protection Agency (EPA) and the California Emission Control Regulation of emission systems, maintenance, and warranty. Replacements may be ordered through the engine manufacturer.

## Introduction

This rotary-blade, walk-behind lawn mower is intended to be used by residential homeowners or professional, hired operators. It is designed primarily for cutting grass on well-maintained lawns on residential or commercial properties. It is not designed for cutting brush or for agricultural uses.

Read this information carefully to learn how to operate and maintain your product properly and to avoid injury and product damage. You are responsible for operating the product properly and safely.

You may contact Toro directly at [www.Toro.com](http://www.Toro.com) for product and accessory information, help finding a dealer, or to register your product.

Whenever you need service, genuine Toro parts, or additional information, contact an Authorized Service Dealer or Toro Customer Service and have the model and serial numbers of your product ready. Figure 1 identifies the location of the model and serial numbers on the product. Write the numbers in the space provided.

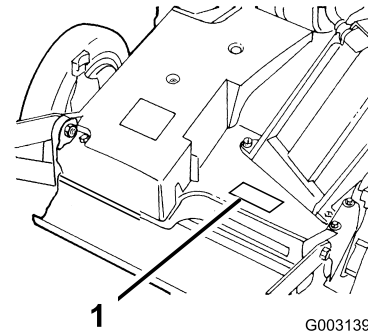

Figure 1

1. Model and serial number location

Model No.	_____
Serial No.	_____

This manual identifies potential hazards and has safety messages identified by the safety alert symbol (Figure 2), which signals a hazard that may cause serious injury or death if you do not follow the recommended precautions.



Figure 2

1. Safety alert symbol

This manual uses 2 words to highlight information. **Important** calls attention to special mechanical information and **Note** emphasizes general information worthy of special attention.

# Contents

Introduction.....	2
Safety .....	4
General Lawn Mower Safety .....	4
Training.....	4
Preparation .....	4
Operation.....	4
Maintenance and Storage.....	5
Safety and Instructional Decals .....	6
Setup .....	7
1 Installing the Handle.....	8
2 Installing the Starter Rope .....	8
3 Installing the Fuel Tank.....	9
4 Installing the Discharge Tunnel Plug.....	10
5 Filling the Crankcase with Oil.....	10
Product Overview .....	11
Operation.....	12
Checking the Engine Oil Level.....	12
Filling the Fuel Tank with Gasoline .....	12
Starting the Engine .....	13
Stopping the Engine .....	14
Operating the Mower Blade .....	14
Operating the Self-Propel Drive.....	14
Using the Discharge Tunnel Plug .....	14
Checking the Blade Brake Clutch .....	15
Adjusting the Cutting Height .....	16
Using the Grass Bag .....	17
Operating Tips .....	18
Maintenance.....	20
Recommended Maintenance Schedule(s) .....	20
Lubrication.....	21
Lubricating the Pivot Arms.....	21
Lubricating the Gear Case.....	21
Engine Maintenance.....	21
Servicing the Air Cleaner .....	21
Changing the Engine Oil .....	22
Servicing the Spark Plug .....	22
Drive System Maintenance .....	23
Adjusting the Self-propel Drive.....	23
Servicing the Wheels .....	24
Controls System Maintenance.....	25
Adjusting the Blade Brake Cable .....	25
Blade Maintenance .....	25
Maintaining the Blade .....	25
Cleaning .....	27
Cleaning under the Mower Housing.....	27
Cleaning the Discharge Tunnel and Plug.....	27
Cleaning under the Belt Cover.....	28
Cleaning the Blade Brake Clutch Shield .....	28
Storage.....	29
Preparing the Fuel System.....	29

Preparing the Engine.....	29
General Information .....	29
Removing the Mower from Storage.....	29
Troubleshooting.....	30

# Safety

This lawn mower meets or exceeds the CPSC blade safety requirements for walk-behind rotary lawn mowers and the B71.4 specifications of the American National Standards Institute in effect at the time of production.

Improperly using or maintaining this lawn mower can result in injury. To reduce the potential for injury, comply with these safety instructions.

Toro designed and tested this lawn mower for to offer reasonably safe service; however, **failure to comply with the following instructions may result in personal injury.**

## **⚠ WARNING**

Engine exhaust contains carbon monoxide, an odorless, deadly poison that can kill you.

Do not run the engine indoors or in an enclosed area.

To ensure maximum safety, best performance, and to gain knowledge of the product, it is essential that you and any other operator of the lawn mower read and understand the contents of this manual before the engine is ever started. Pay particular attention to the safety alert symbol (Figure 2) which means Caution, Warning, or Danger—“personal safety instruction.” Read and understand the instruction because it has to do with safety. Failure to comply with the instruction may result in personal injury.

## General Lawn Mower Safety

This lawn mower is capable of amputating hands and feet and of throwing objects. Failure to observe the following safety instructions could result in serious injury or death.

The following instructions are from the ANSI/OPEI B71.4–2004 standard.

## Training

- Read the Operator’s Manual and other training material. If the operator(s) or mechanic(s) cannot read English it is the owner’s responsibility to explain this material to them.
- Become familiar with the safe operation of the equipment, operator controls, and safety signs.
- All operators and mechanics should be trained. The owner is responsible for training the users.

- Never let children or untrained people operate or service the equipment. Local regulations may restrict the age of the operator.
- The owner/user can prevent and is responsible for accidents or injuries occurring to themselves, other people or property.

## Preparation

- Evaluate the terrain to determine what accessories and attachments are needed to properly and safely perform the job. Only use accessories and attachments approved by the manufacturer.
- Wear appropriate clothing, including safety glasses and hearing protection. Long hair, loose clothing or jewelry may get tangled in moving parts.
- Inspect the area where the equipment is to be used and remove all objects such as rocks, toys and wire which can be thrown by the machine.
- Use extra care when handling gasoline and other fuels. They are flammable and vapors are explosive.
  - Use only an approved container.
  - Never remove gas cap or add fuel when engine is running. Do not smoke.
  - Never refuel or drain the machine indoors.
- Check that operator’s presence controls, safety switches and shields are attached and functioning properly. Do not operate unless they are functioning properly.

## Operation

- Never run an engine in an enclosed area.
- Only operate in good light, keeping away from holes and hidden hazards.
- Be sure all drives are in neutral and parking brake is engaged before starting engine. Only start engine from the operator’s position.
- Be sure of your footing while using pedestrian controlled equipment, especially when backing up. Walk, don’t run. Never operate on wet grass. Reduced footing could cause slipping.
- Slow down and use extra care on hillsides. Be sure to travel side to side on hillsides. Use caution while operating near drop-offs.
- Slow down and use caution when making turns and when changing directions on slopes.
- Never raise deck with the blades running.

- Never operate with the discharge deflector raised, removed or altered, unless using a grass catcher.
- Do not change the engine governor setting or overspeed the engine.
- Stop on level ground and shut off engine before leaving the operator's position for any reason including emptying the catchers or unclogging the chute.
- Stop equipment and inspect blades after striking objects or if an abnormal vibration occurs. Make necessary repairs before resuming operations.
- Keep hands and feet away from the cutting units.
- Look behind and down before backing up to be sure of a clear path.
- Be aware of the mower discharge direction and do not point it at anyone.
- Do not operate the mower under the influence of alcohol or drugs.
- Use care when loading or unloading the machine into a trailer or truck.
- Use care when approaching blind corners, shrubs, trees, or other objects that may obscure vision.

## **Maintenance and Storage**

- Wait for all movement to stop before adjusting, cleaning or repairing.
- Clean grass and debris from cutting unit, muffler, and engine to help prevent fires. Clean up oil or fuel spillage.
- Let engine cool before storing and do not store near flame.
- Do not store fuel near flames or drain indoors.
- Never allow untrained personnel to service machine.
- Use care when checking blade. Wrap the blade or wear gloves, and use caution when servicing. Only replace blade. Never straighten or weld them.
- Keep hands and feet away from moving parts. If possible, do not make adjustments with the engine running.
- Keep all parts in good working condition and all hardware tightened. Replace all worn or damaged decals.

# Safety and Instructional Decals



Safety decals and instructions are easily visible to the operator and are located near any area of potential danger. Replace any decal that is damaged or lost.

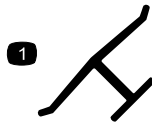

**Manufacturer's Mark**

1. Indicates the blade is identified as a part from the original machine manufacturer.

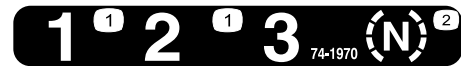

**74-1970**

1. Transmission speeds
2. Neutral



**94-8072**



**98-4387**

1. Warning—wear hearing protection.

## CALIFORNIA SPARK ARRESTER WARNING

Operation of this equipment may create sparks that can start fires around dry vegetation. A spark arrester may be required. The operator should contact local fire agencies for laws or regulations relating to fire prevention requirements.

117-2718

**117-2718**

Model 74625 only



**68-7410**

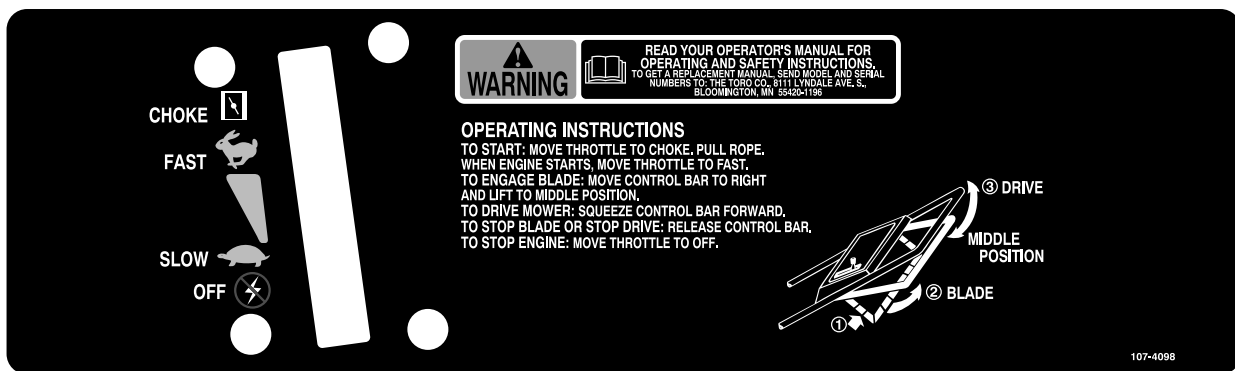

**107-4098**



**112-8736**

# Setup

## Loose Parts

Use the chart below to verify that all parts have been shipped.

Procedure	Description	Qty.	Use
<b>1</b>	Handle	1	Install the handle.
	Bolt (5/16 x 1-1/4 inches)	2	
	Washer	4	
	Thin nylon insert locknut (5/16 inch)	2	
	Bolt (5/16 x 1-1/2 inches)	2	
	Carriage bolt	1	
	Locknut (5/16 inch)	2	
	Bag support rod	1	
	Bag aligning plate	1	
	Cap locknut	3	
	Cable tie	3	
<b>2</b>	No parts required	–	Install the starter rope.
<b>3</b>	Self-tapping screw	2	Install the fuel tank.
	Fuel tank	1	
	Hose clamp	1	
<b>4</b>	Discharge tunnel plug	1	Install the discharge tunnel plug.
<b>5</b>	No parts required	–	Fill the crankcase with oil.

**Note:** Determine the left and right sides of the machine from the normal operating position.

# 1

## Installing the Handle

### Parts needed for this procedure:

1	Handle
2	Bolt (5/16 x 1-1/4 inches)
4	Washer
2	Thin nylon insert locknut (5/16 inch)
2	Bolt (5/16 x 1-1/2 inches)
1	Carriage bolt
2	Locknut (5/16 inch)
1	Bag support rod
1	Bag aligning plate
3	Cap locknut
3	Cable tie

### Procedure

1. Mount the handle to the outside of the mower housing (using the bottom hole) with two bolts (5/16 x 1-1/4 inches), washers, and thin locknuts (5/16 inch) (Figure 3).

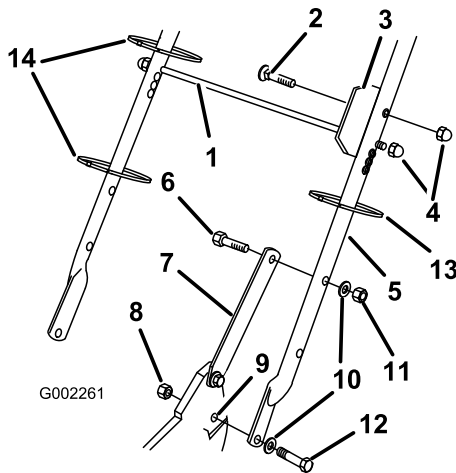

Figure 3

- |                                    |                                     |
|------------------------------------|-------------------------------------|
| 1. Bag support rod                 | 8. Thin nylon insert locknut (2)    |
| 2. Carriage bolt                   | 9. Bottom hole in housing           |
| 3. Bag aligning plate              | 10. Washer (4)                      |
| 4. Cap locknuts (3)                | 11. Locknut (2)                     |
| 5. Handle                          | 12. Bolt, (5/16 x 1-1/4 inches) (2) |
| 6. Bolt, (5/16 x 1-1/2 inches) (2) | 13. Cable tie (3)                   |
| 7. Handle latch (2)                |                                     |

2. Secure the handle latches to the handle with 2 bolts (5/16 x 1-1/2 inches), washers, and locknuts (5/16 inch) (Figure 3).

**Note:** You can adjust the handle height for comfortable operation. Stand behind the handle to determine the height. To adjust the handle height, position the bolts and the locknuts that secure the handle latches to the handle into the other mounting holes in the latches.

3. Insert the carriage bolt through the bag aligning plate and the second from the top hole on the left side of the handle, and secure it with a cap locknut (Figure 3).
4. Slide the bag support rod through the third from the top mounting holes in the handle, and secure each end with a cap locknut (Figure 3).
5. Use cable ties to secure the control cables to the handle (Figure 3).

# 2

## Installing the Starter Rope

### No Parts Required

### Procedure

Pull the starter rope through the rope guide on the handle (Figure 4).

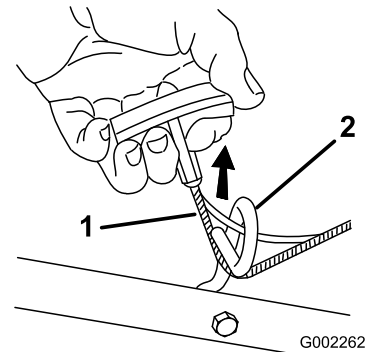

Figure 4

- |                 |               |
|-----------------|---------------|
| 1. Starter rope | 2. Rope guide |
|-----------------|---------------|

**Note:** To make the rope easier to install, squeeze the blade control bar on the handle.

# 3

## Installing the Fuel Tank

### Parts needed for this procedure:

2	Self-tapping screw
1	Fuel tank
1	Hose clamp

### Procedure

1. Slide the plastic clips, on the front of the fuel tank, onto the fuel tank mount (Figure 5).

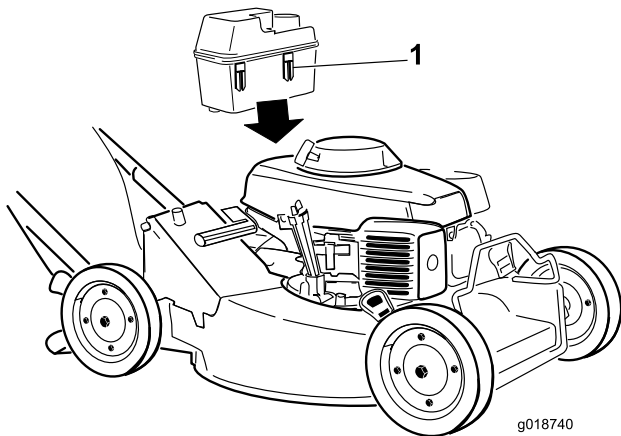

Figure 5

1. Fuel tank plastic clip (2)

2. Secure the bottom of the fuel tank to the fuel tank bracket by installing the self-tapping screws from the bottom. **Torque the screws to 40 to 50 in-lb (4.5 to 5.6 N-m).**
3. Insert the hose clamp onto the fuel line from the fuel filter (Figure 6).

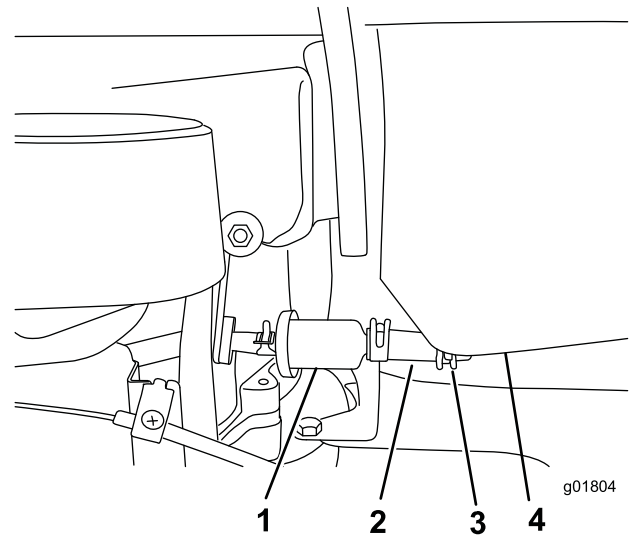

Figure 6

1. Fuel filter
2. Hose clamp

3. Fuel line

4. Slide the end of the fuel line onto the fuel tank fitting (Figure 6).
5. Secure the fuel line to the fuel tank with the hose clamp (Figure 6).

# 4

## Installing the Discharge Tunnel Plug

### Parts needed for this procedure:

1	Discharge tunnel plug
---	-----------------------

### Procedure

1. Open the discharge door by pulling the handle rearward (Figure 7). Hold the discharge door handle to prevent the spring-loaded door from closing while you insert the plug.

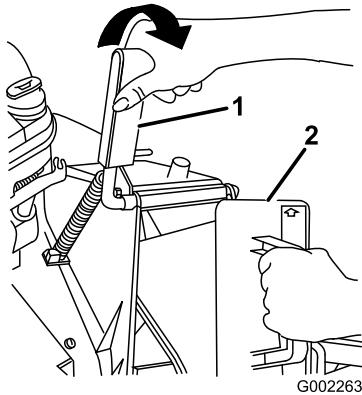

Figure 7

1. Discharge door handle
2. Plug, rotated clockwise

2. Since the plug is slightly wider than the discharge tunnel opening, rotate the plug clockwise slightly while inserting it (Figure 7).

**Note:** Ensure that the arrow on the plug decal points upward.

3. Push the plug all the way in until the spring clip on the bottom of the plug clicks into place, locking the plug securely into the discharge tunnel (Figure 8).

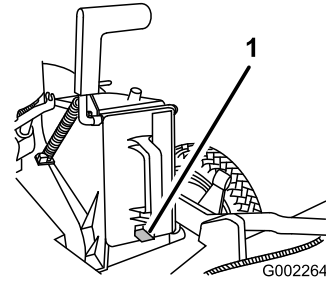

Figure 8

1. Spring clip

4. Release the discharge door handle to lock the top of the plug.

# 5

## Filling the Crankcase with Oil

### No Parts Required

### Procedure

The engine crankcase is shipped without oil. The engine crankcase can hold 22 ounces (0.65 liters) of oil. Use only high-quality SAE 10W-30 weight detergent oil that has the American Petroleum Institute (API) service classification SH, SJ, or equivalent.

Before each use, ensure that the oil level is between the lower limit and upper limit marks on the dipstick (Figure 9).

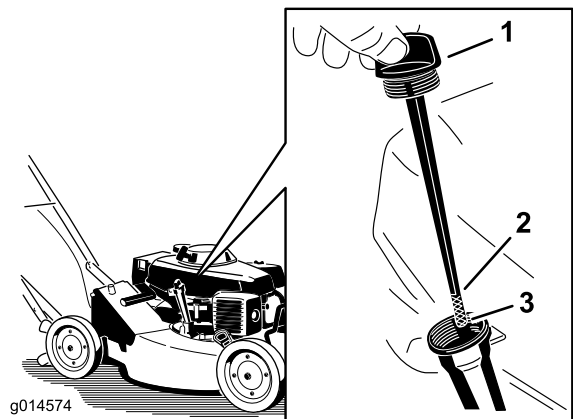

Figure 9

1. Dipstick
2. Upper limit mark
3. Lower limit mark

**Note:** When the crankcase is empty, pour about 3/4 of the crankcase capacity of oil in the crankcase, then follow the procedure in this section.

1. Move the mower to a level surface.
  2. Clean around the dipstick (Figure 9).
  3. Remove the dipstick by rotating the cap counterclockwise and pulling it out.
  4. Wipe the dipstick clean with a clean cloth.
  5. Insert the dipstick into the filler neck (but **do not rotate the cap clockwise to secure it**), then remove it.
  6. Read the oil level on the dipstick.
  7. If the oil level reading is below the lower limit mark on the dipstick, remove the dipstick and **slowly** pour only enough oil into the filler hole to raise the oil level to the upper limit mark on the dipstick.
- Important: Do not overfill the crankcase with oil and run the engine; engine damage will result. Drain the excess oil until the oil level reaches the upper limit mark on the dipstick.**
8. Insert the dipstick into the filler neck and rotate the cap clockwise until it is tight.

# Product Overview

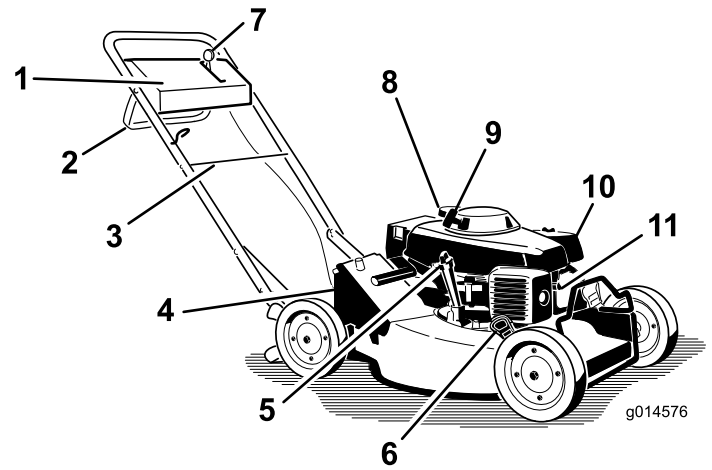

**Figure 10**

- |                         |                        |
|-------------------------|------------------------|
| 1. Control panel        | 7. Throttle lever      |
| 2. Blade control bar    | 8. Recoil start handle |
| 3. Bag support bar      | 9. Fuel tank cap       |
| 4. Discharge tunnel     | 10. Air cleaner        |
| 5. Oil fill/dipstick    | 11. Spark plug         |
| 6. Cutting height lever |                        |

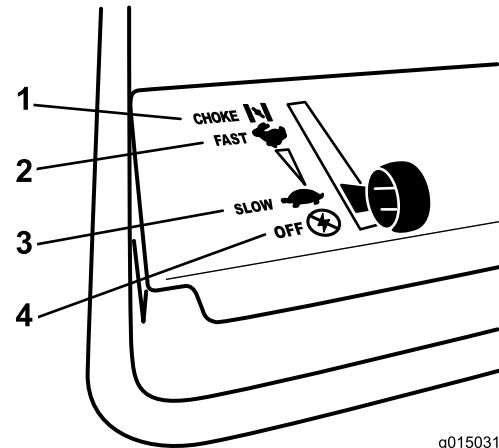

**Figure 11**  
Throttle

- |         |          |
|---------|----------|
| 1. Stop | 3. Fast  |
| 2. Slow | 4. Choke |

# Operation

**Note:** Determine the left and right sides of the machine from the normal operating position.

Each time before you mow, make sure that the self-propel drive and the blade control bar operate properly. When you release the blade control bar, the blade and self-propel drive should stop. If they do not, contact an Authorized Service Dealer.

## ⚠ CAUTION

This machine produces sound levels in excess of 85dBA at the operator's ear and can cause hearing loss through extended periods of exposure.

Wear hearing protection when operating this machine.



Figure 12

1. Warning—wear hearing protection.

## Checking the Engine Oil Level

**Service Interval:** Before each use or daily

Before you use the mower, ensure that the oil level is between the lower limit and upper limit marks as shown on the dipstick (Figure 13).

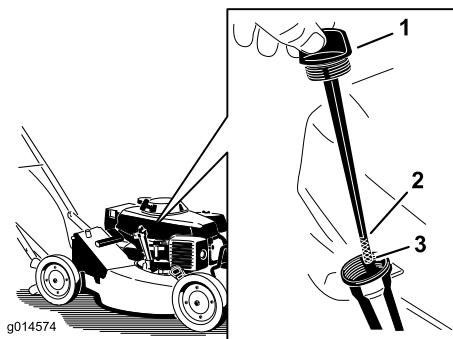

Figure 13

1. Dipstick
2. Upper limit mark
3. Lower limit mark

If the oil level is below the lower limit mark, add oil. Refer to Filling the Crankcase with Oil.

## Filling the Fuel Tank with Gasoline

For best results, use clean, fresh, lead-free gasoline with an octane rating of 87 or higher. To ensure freshness, purchase only the quantity of gasoline that you expect to use in 30 days. Using unleaded gasoline results in fewer combustion deposits and longer engine life. You may use leaded gasoline if unleaded gasoline is not available.

**Important:** Do not add oil to the gasoline.

**Important:** Do not use methanol, gasoline containing methanol, gasohol containing more than 10% ethanol, premium gasoline, or white gas. Using these fuels can damage the engine's fuel system.

**Important:** Do not use gasoline that has been stored more than 30 days old.

## ⚠ DANGER

In certain conditions, gasoline is extremely flammable and highly explosive. A fire or explosion from gasoline can burn you and others and can damage property.

- Fill the fuel tank outdoors, in an open area, and when the engine is cold. Wipe up any gasoline that spills.
- Do not fill the fuel tank completely full. Add gasoline to the fuel tank until the level is 1/4 to 1/2 in. (6 to 13 mm) below the bottom of the filler neck. This empty space in the tank allows the gasoline to expand.
- Never smoke when handling gasoline, and stay away from an open flame or where a spark may ignite the gasoline fumes.
- Store gasoline in an approved fuel container and keep it out of the reach of children.
- Never buy more than a 30-day supply of gasoline.

## **⚠ DANGER**

When fueling, under certain circumstances, a static charge can develop, igniting the gasoline. A fire or explosion from gasoline can burn you and others and damage property.

- Always place gasoline containers on the ground and away from your vehicle before filling.
- Do not fill gasoline containers inside a vehicle or on a truck or trailer bed because interior carpets or plastic truck bed liners may insulate the container and slow the loss of any static charge.
- When practical, remove gasoline-powered equipment from the truck or trailer and refuel the equipment with its wheels on the ground.
- If this is not possible, then refuel such equipment on a truck or trailer from a portable container, not from a gasoline dispenser nozzle.
- If you must use a gasoline dispenser nozzle, keep the nozzle in contact with the rim of the fuel tank or container opening at all times until fueling is complete.

Use a fuel stabilizer/conditioner regularly during operation and storage. A stabilizer/conditioner cleans the engine during operation and prevents gum-like varnish deposits from forming in the engine during periods of storage.

**Important:** Do not use fuel additives other than a fuel stabilizer/conditioner. Do not use fuel stabilizers with an alcohol base such as ethanol, methanol, or isopropanol.

1. Clean around the fuel tank cap (Figure 14).

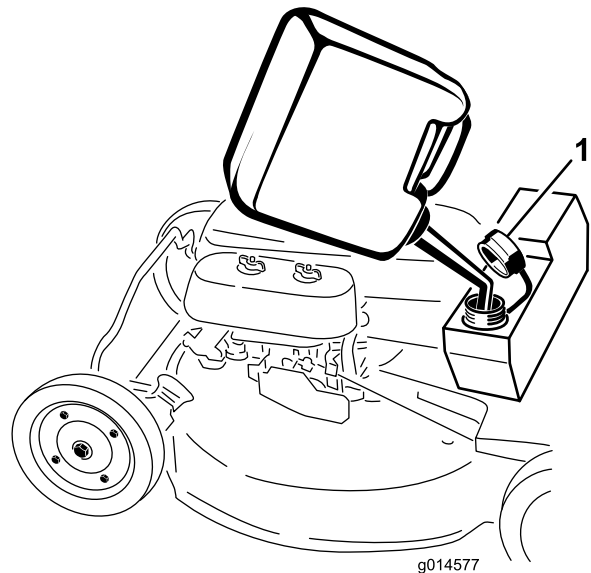

**Figure 14**

1. Fuel tank cap

2. Remove the fuel tank cap.
3. Fill the fuel tank with unleaded gasoline to within 1/4 to 1/2 inch (6 to 13 mm) from the top of the tank. **Do not fill into the filler neck.**

**Note:** The fuel tank capacity is 1 US Gallon. (3.8 L).

**Important:** Fill the tank no further than the bottom of the filler neck. Do not fill into the filler neck. The gasoline must have room to expand.

4. Install the fuel tank cap and wipe up any spilled gasoline.

## **Starting the Engine**

1. Connect the wire to the spark plug.
2. Open the fuel valve by moving the lever to the **right** (Figure 15)

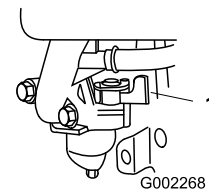

**Figure 15**

1. Fuel valve

3. Move the throttle control to the Choke position.

**Note:** Do not use the choke when the engine is warm.

- Pull the starter handle lightly until you feel resistance, then pull it sharply. Allow the rope to return to the handle slowly.
- When the engine starts, move the throttle control to the Fast position, and set the ground speed control as desired.

**Note:** If the engine fails to start after 3 pulls, repeat steps 4 through 5.

## Stopping the Engine

- Release the blade control bar and move the throttle control to the Off position.
- Disconnect the wire from the spark plug if you do not use the lawn mower or if you leave it unattended.

## Operating the Mower Blade

This mower is equipped with a blade brake clutch. To engage the mower blades and cut grass, do the following:

**Important:** Refer to Checking the Blade Brake Clutch for important information on ensuring that the blade brake clutch is working properly.

- With the engine running, push the blade control bar to the right.
- Lift the blade control bar to the Run/Shift position or Run/Drive position to start the blades (Figure 17).

**Note:** If you move to the Run/Drive position, you will engage the self-propel drive as well; refer to Operating the Self-Propel Drive.

## Operating the Self-Propel Drive

The mower has three ground speeds. 1 is slow, 2 is medium, and 3 is fast. The ground speed control is located at the rear of the belt cover (Figure 16).

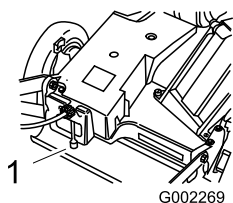

**Figure 16**

- Ground speed control
- 
- Move the ground speed control to the Neutral position (Figure 16).

- Start the engine.
- Squeeze the blade control bar to the Run/Shift position (Figure 17) and move the ground speed control to the desired speed setting (Figure 16).

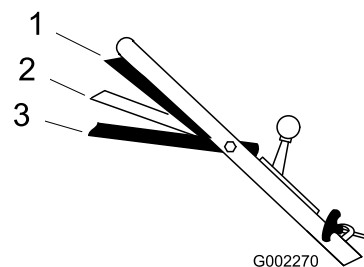

**Figure 17**

- Run/Drive position
- Run/Shift position
- Stop position

- 
- Squeeze the blade control bar against the handle to the Run/Drive position (Figure 17).

**Important:** Do not shift speeds while squeezing the blade control bar against the handle in the Run/Drive position; this can damage the transmission. Move the blade control bar to the Run/Shift position when you change the ground speed.

**Note:** You can vary the ground speed by increasing or decreasing the distance between the blade control bar and the handle. Lower the blade control bar to decrease the ground speed when you are making a turn or if the mower is moving too fast for you. If you lower the blade control bar too far, the mower stops self-propelling. Squeeze the blade control bar closer to the handle to increase the ground speed. When you hold the blade control bar tight against the handle, the mower self-propels at the maximum ground speed. Move the ground speed control to the Neutral position when you use the mower for trimming or whenever you leave the mower.

## Using the Discharge Tunnel Plug

- Stop the engine and wait for all moving parts to stop.
- Insert the plug; refer to Installing the Discharge Tunnel Plug.
- To remove the plug, move the discharge door handle rearward and lift up the spring clip on the bottom of the plug. When the plug is unlocked, pull it out of the discharge tunnel.

**Note:** When grass is thick and lush, clippings may collect on and around the discharge tunnel plug. This may make removing the plug difficult. Clean the plug thoroughly after each use.

## Checking the Blade Brake Clutch

Check the operation of the blade brake clutch before each use to ensure that it is operating properly.

### Normal Test

1. Stop the engine and wait for all moving parts to stop.
2. Move the mower onto a paved surface in a non-windy area.
3. Set all 4 wheels in to the 2-3/4 inch (70 mm) cutting height setting.
4. Set the ground speed selector to the Neutral position.
5. Take a half sheet of newspaper and crumple it into a ball small enough to go under the housing (about 3 inches or 76 mm in diameter).
6. Place the ball of newspaper 5 inches (12.7 cm) in front of the mower (Figure 18).

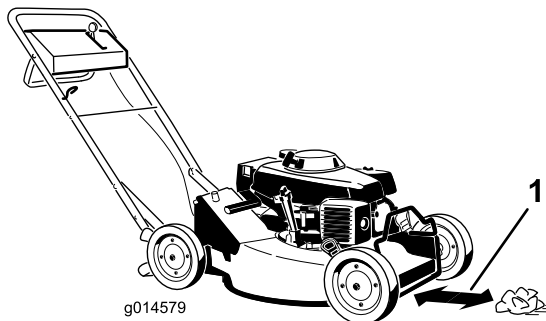

**Figure 18**

1. 5 inches (12.7 cm)

7. Start the engine.
8. Ensure that the blade control bar down is in the lowest position (Figure 19).

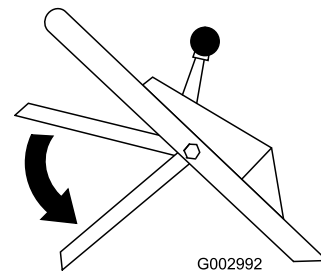

**Figure 19**

9. Push the blade control bar to the right.
10. Lift the blade control bar up to about one inch (2.5 cm) below the handle; refer to position A in Figure 20.

**Note:** The fan-like noise indicates that the mower blade is turning.

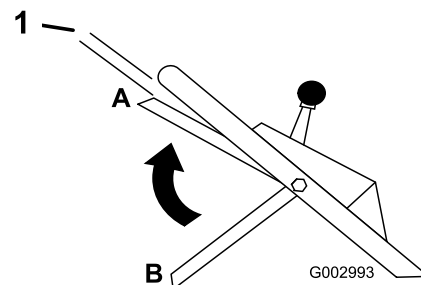

**Figure 20**

1. 1 inch (2.5 cm)

11. Release the blade control bar; refer to position B in Figure 21. You should hear a “bang.” The blade should stop in 3 seconds.

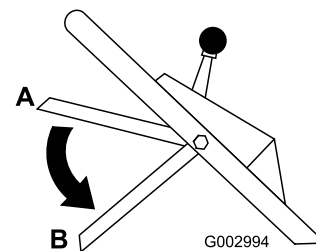

**Figure 21**

12. Immediately push the mower over the newspaper ball.
13. Stop the engine and wait for all moving parts to stop.
14. Walk around the mower to check for the newspaper ball. If the ball did not go under the housing, repeat steps 6 through 13.
15. Pull the mower away from the newspaper. If the newspaper ball unravels or is shredded, the blade has not properly stopped, resulting in an unsafe

operating condition. Contact an Authorized Service Dealer.

To check for a problem with the blade brake clutch system **before** it affects its normal operation, you can perform the Special Test that follows.

## Special Test

1. Follow steps 1 through 7 from the Normal Test.
2. Ensure that the blade control bar down is in the lowest position (Figure 19).
3. Move the blade control bar to the right.
4. Bring the blade control bar up into the middle position about 5 inches (12.7 cm) below the handle cross bar (Position C in Figure 22).

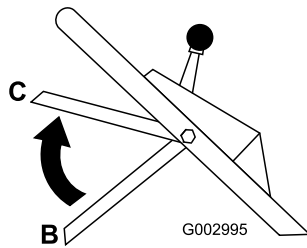

Figure 22

**Note:** This intermediate position (C) is not the normal operating position of the blade control bar. However, it helps to detect a sticking blade brake clutch system early enough to prevent an unsafe condition later.

5. Release the blade control bar (Position B in Figure 22).
- Note:** If you hear a loud “bang,” you have raised the blade control bar too high. Repeat steps 2 through 5 above, but do not raise the blade control bar as high as in step 4.
6. Immediately push the mower over the newspaper ball.
  7. Stop the engine and wait for all moving parts to stop.
  8. Walk around the mower to check for the newspaper ball. If the ball did not go under the housing:
    - A. Place the ball of newspaper 5 inches (12.7 cm) in front of the mower (Figure 18).
    - B. Start the engine.
    - C. Follow steps 2 through 7 above.
  9. Pull the mower away from the newspaper. If the newspaper ball unravels or is shredded, the blade

brake clutch system could be deteriorating to the point where it could result in an unsafe operating condition. Contact an Authorized Service Dealer for an inspection and repair of your mower.

## ⚠ DANGER

If the blade brake clutch system is inoperative, the blade will continue to rotate when you release the blade control bar. Contact with blade could occur, causing serious injury.

- Check the blade brake clutch operation before each use.
- Never use a blade brake clutch-equipped mower with an inoperative safety system.
- Take your mower to an Authorized Service Dealer for repair if the safety system fails to operate properly.

## Test Using the Grass Bag

You can use the grass bag to perform an additional test to check the blade brake clutch:

1. Install the empty grass bag on the discharge tunnel.
2. Start the engine.
3. Move the blade control bar down to its lowest position (Figure 19).
4. Push the blade control bar to the right.
5. Lift the blade control bar to the normal blade engaged position about one inch (2.5 cm) below the handle. The bag should begin to inflate, indicating that the blade is engaged and rotating.
6. Release the blade control bar. If the bag does not immediately deflate, it indicates that the blade is still rotating. The blade brake clutch may be deteriorating, and, if ignored, could result in an unsafe operating condition. Have the mower inspected and serviced by an Authorized Service Dealer.

## Adjusting the Cutting Height

Each wheel is adjusted individually with a wheel height adjustment lever. Cutting heights are 3/4 inch (19 mm), 1-1/4 inches (32 mm), 1-3/4 inches (44 mm), 2-1/4 inches (57 mm), 2-3/4 inches (70 mm), and 3-1/4 inches (83 mm).

## **⚠ DANGER**

Adjusting the cutting height levers could bring your hands into contact with a moving blade and result in serious injury.

- Stop the engine and wait for all movement to stop before adjusting the cutting height.
  - Do not put your fingers under the housing when adjusting the cutting height.
1. Pull the wheel height adjustment lever toward the wheel (Figure 23) and move it to the desired setting.

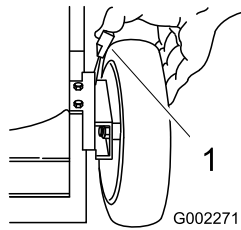

**Figure 23**

1. Wheel height adjustment lever

2. Release the wheel height adjustment lever and seat it securely in the notch.
3. Adjust all the wheels to the same cutting height setting.

## Using the Grass Bag

Occasionally, you may wish to use the grass bag for bagging extra long grass, lush grass, or leaves.

### Installing the Grass Bag

1. Stop the engine and wait for all moving parts to stop.
2. Ensure that the discharge door handle is fully forward and that the pin is engaged in the catch (Figure 24).

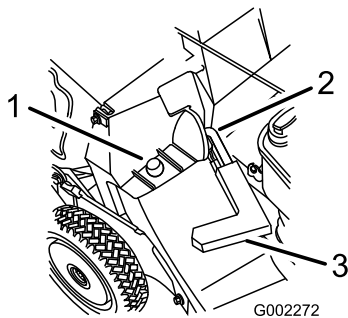

**Figure 24**

1. Bag frame on retaining post
2. Pin engaged in catch
3. Handle fully forward; discharge door closed

3. Slide the hole in the bag frame onto the retaining post on the discharge tunnel (Figure 24).
4. Set the rear of the bag frame onto the bag support rod.
5. Pull the discharge door handle forward until the pin clears the catch, and move the handle rearward until the pin locks in the bag notch (Figure 25).

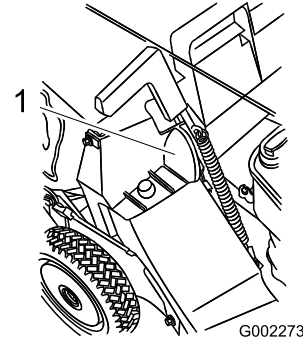

**Figure 25**

1. Pin locked in bag notch

**Note:** The discharge door in the mower housing is now open.

## Mowing with the Grass Bag

### **⚠ WARNING**

A worn grass bag could allow small stones and other similar debris to be thrown in the operator's or bystander's direction and result in serious personal injury or death to the operator or bystanders.

Check the grass bag frequently. If it is damaged, install a new Toro replacement bag.

### Removing the Grass Bag

1. Stop the engine and wait for all moving parts to stop.
2. Raise the discharge door handle and move it forward to engage the pin with the catch (Figure 24).
3. Grasp the handles at the front and the rear of the bag and lift the bag off the mower.
4. Gradually tip the bag forward to empty the clippings.
5. To install the bag, refer to Installing the Grass Bag.

## **⚠ DANGER**

If the discharge door does not close completely, the mower could throw objects, causing serious personal injury or death.

If you cannot close the door because the grass clippings clog the discharge area, stop the engine and gently move the discharge door handle back and forth until you can close the door completely. If you still cannot close the door, remove the obstruction with a stick, not your hand.

## **⚠ DANGER**

The mower can throw grass clippings and other objects through an open discharge tunnel. Objects thrown with enough force could cause serious personal injury or death to the operator or bystander.

Never open the door on the discharge tunnel when the engine is running.

## **Operating Tips**

### **General Tips**

- Review the safety instructions and read this manual carefully before operating the mower.
- Clear the area of sticks, stones, wire, branches, and other debris that the blade could hit and throw.
- Keep everyone, especially children and pets, away from the area of operation.
- Avoid striking trees, walls, curbs, or other solid objects. Never deliberately mow over any object.
- If the mower strikes an object or starts to vibrate, immediately stop the engine, disconnect the wire from the spark plug, and examine the mower for damage.
- Maintain a sharp blade throughout the cutting season. Periodically file down nicks on the blade.
- Replace the blade when necessary with an original Toro replacement blade.
- Mow only dry grass or leaves. Wet grass and leaves tend to clump on the yard and can cause the mower to plug or the engine to stall.

## **⚠ WARNING**

**Wet grass or leaves can cause serious injury if you slip and contact the blade.**

**Mow only in dry conditions.**

- Clean under the mower housing after each mowing. See Cleaning under the Mower Housing.
- Keep the engine in good running condition.
- Set the engine speed to the fastest position for the best cutting results.

## **⚠ WARNING**

**Operating a mower with its engine running at a speed greater than the factory setting can cause the mower to throw a part of the blade or engine into the operator's or bystander's area and result in serious personal injury or death.**

- **Do not change the engine speed setting.**
  - **If you suspect the engine speed is faster than normal, contact an Authorized Service Dealer.**
- Clean the air filter frequently. Mulching stirs up more clippings and dust which clogs the air filter and reduces engine performance.

## **Cutting Grass**

- Grass grows at different rates at different times of the year. In the summer heat, it is best to cut grass at the 2-1/4 inch (57 mm), 2-3/4 inch (70 mm), or 3-1/4 inch (83 mm) cutting height settings. Cut only about a third of the grass blade at a time. Do not cut below the 2-1/4 inch (57 mm) setting unless the grass is sparse or it is late fall when grass growth begins to slow down.
- When cutting grass over 6 inches (15 cm) tall, first mow at the highest cutting height setting and walk slower; then mow again at a lower setting for the best lawn appearance. If the grass is too long and the leaves clump on top of the lawn, the mower may plug and cause the engine to stall.
- Alternate the mowing direction. This helps disperse the clippings over the lawn for even fertilization.

If the finished lawn appearance is unsatisfactory, try one or more of the following:

- Sharpen the blade.
- Walk at a slower pace while mowing.
- Raise the cutting height on your mower.
- Cut the grass more frequently.
- Overlap cutting swaths instead of cutting a full swath with each pass.
- Set the cutting height on the front wheels one notch lower than the rear wheels. For example, set the

front wheels at 2-1/4 inches (57 mm) and the rear wheels at 2-3/4 inches (70 mm).

## Cutting Leaves

- After cutting the lawn, ensure that half of the lawn shows through the cut leaf cover. You may need to make more than one pass over the leaves.
- For light leaf coverage, set all the wheels at the same cutting height setting.
- If there are more than 5 inches (12.7 cm) of leaves on the lawn, set the front cutting height 1 or 2 notches higher than the rear cutting height. This makes it easier to feed the leaves under the mower housing.
- Slow down your mowing speed if the mower does not cut the leaves finely enough.
- If you mow over oak leaves, you can add lime to the grass in the spring to reduce the acidity of the oak leaves.

# Maintenance

**Note:** Determine the left and right sides of the machine from the normal operating position.

## ***Recommended Maintenance Schedule(s)***

Maintenance Service Interval	Maintenance Procedure
After the first 5 hours	<ul style="list-style-type: none"> <li>• Change the engine oil.</li> </ul>
Before each use or daily	<ul style="list-style-type: none"> <li>• Check the engine oil level.</li> <li>• Check the blade brake clutch operation.</li> <li>• Inspect the air cleaner elements.</li> <li>• Inspect the mower blades for wear or damage.</li> <li>• Clean under the mower housing.</li> <li>• Clean the discharge tunnel and the discharge tunnel plug.</li> <li>• Check the stopping time of the blade brake. The blade must stop within 3 seconds of releasing the blade control bar; if it does not, contact an Authorized Service Dealer for repair.</li> </ul>
Every 25 hours	<ul style="list-style-type: none"> <li>• Lubricate the pivot arms.</li> <li>• Clean the air filter elements. Clean them more frequently in dusty operating conditions.</li> <li>• Check the blade and engine mounting fasteners. Tighten loose fasteners.</li> </ul>
Every 50 hours	<ul style="list-style-type: none"> <li>• Change the engine oil.</li> <li>• Sharpen or replace the blade.</li> <li>• Remove grass clippings and debris from under the belt cover.</li> <li>• Clean the blade brake clutch shield.</li> <li>• Have an authorized engine servicing dealer check the flywheel brake operation.</li> </ul>
Every 100 hours	<ul style="list-style-type: none"> <li>• Lubricate the gear case.</li> <li>• Inspect, clean, and adjust the spark plug; replace it if necessary.</li> <li>• Adjust the self-propel drive.</li> <li>• Service the wheels.</li> <li>• Adjust the blade brake cable.</li> <li>• Have an authorized engine servicing dealer check and adjust the flywheel brake pad.</li> </ul>
Every 250 hours	<ul style="list-style-type: none"> <li>• Replace the air cleaner elements. Replace them more frequently in dusty operating conditions.</li> <li>• Replace the spark plug.</li> <li>• Have an authorized engine servicing dealer check for leaks in the fuel system and/or a deteriorating fuel hose. Replace parts if necessary.</li> <li>• Have an authorized engine servicing dealer check and adjust the engine idle speed, check and adjust the valve clearance, and clean the fuel tank and filter.</li> </ul>

**Important:** Refer to your *Engine Operator's Manual* for additional maintenance procedures.

### **▲ CAUTION**

If you leave the wire on the spark plug, someone could accidentally start the engine and seriously injure you or other bystanders.

Disconnect the wire from the spark plug before you do any maintenance. Set the wire aside so that it does not accidentally contact the spark plug.

# Lubrication

## Lubricating the Pivot Arms

**Service Interval:** Every 25 hours

1. Move the rear wheel cutting height levers to the center setting.
2. Wipe the grease fittings with a clean rag (Figure 26).

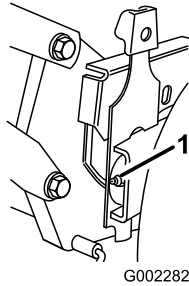

**Figure 26**

1. Grease fitting

- 
3. Install a grease gun onto the fitting and gently apply 2 or 3 pumps of #2 multi-purpose lithium base grease (Figure 26).

**Important:** Excessive grease pressure may damage the seals.

## Lubricating the Gear Case

**Service Interval:** Every 100 hours

1. Remove the grass bag.
2. Install a grease gun onto the fitting through the belt cover opening (Figure 27).

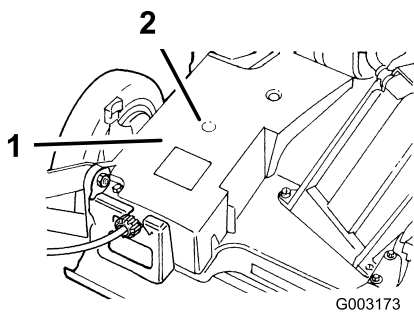

**Figure 27**

1. Belt cover
2. Grease fitting

- 
3. Gently apply one to 2 pumps of #2 multi-purpose lithium-base grease.
  4. Install the grass bag.

# Engine Maintenance

## Servicing the Air Cleaner

**Service Interval:** Before each use or daily—Inspect the air cleaner elements.

Every 25 hours—Clean the air filter elements. Clean them more frequently in dusty operating conditions.

Every 250 hours—Replace the air cleaner elements. Replace them more frequently in dusty operating conditions.

**Important:** Do not operate the engine without the air filter assembly; extreme engine damage will occur.

1. Stop the engine and wait for all moving parts to stop.
2. Disconnect the wire from the spark plug.
3. Remove the 2 nuts that secure the cover (Figure 28).

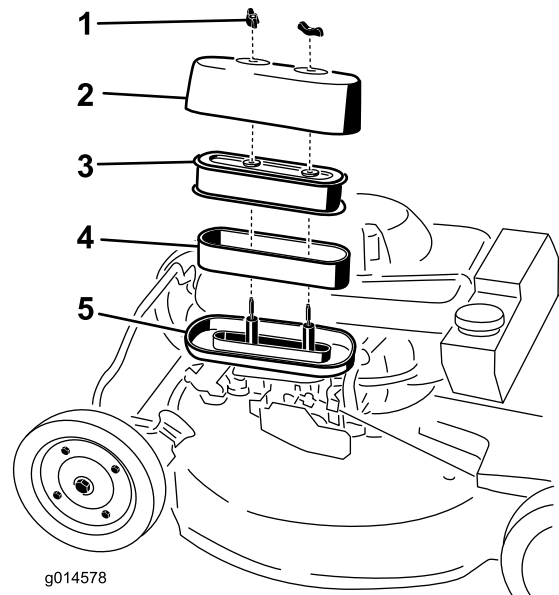

**Figure 28**

1. Nut (2)
2. Cover
3. Paper element
4. Foam element
5. Base

- 
4. Remove the cover.

**Note:** Be careful to prevent dirt and debris from falling into the base.

5. Remove the foam and paper elements from the base (Figure 28).

- Remove the foam element from the paper element (Figure 28).
- Inspect the foam and paper elements, and replace them if they are damaged or excessively dirty.
- If the paper element is excessively dirty, replace it.

**Note:** Never try to brush dirt off the paper element; brushing forces the dirt into the fibers.

- Clean the foam element in warm, soapy water or in a **nonflammable** solvent.

**Note:** Do not use gasoline to clean the foam element because it could create a risk of fire or explosion.

- Rinse and dry the foam element thoroughly.
- Dip the foam element in clean engine oil, then squeeze out the excess oil.

**Note:** Excess oil in the foam element restricts the air flow through the element and may reach the paper filter and clog it.

- Wipe dirt from the base and the cover with a moist rag.

**Note:** Be careful to prevent dirt and debris from entering the air duct leading to the carburetor.

- Install the air cleaner elements and ensure that they are properly positioned.
- Securely install the cover with the 2 nuts.

## Changing the Engine Oil

**Service Interval:** After the first 5 hours  
Every 50 hours

- Run the engine to warm the engine oil.

**Note:** Warm oil flows better and carries more contaminants.

### **⚠ WARNING**

Oil may be hot after engine has been run, and contact with hot oil can cause severe personal injury.

Avoid contacting the hot engine oil when you drain it.

- Stop the engine and wait for all moving parts to stop.
- Disconnect the wire from the spark plug.
- Place a suitable drain pan under the dipstick/oil drain.
- Clean around the dipstick.
- Remove the dipstick by rotating the cap counterclockwise and pulling it out.

- Raise the **left** side of the mower to drain the oil from the dipstick fill tube into the drain pan.
- After draining the oil, return the mower to its operating position.
- Fill the crankcase to the upper limit mark on the dipstick with fresh oil. Refer to the Filling the Crankcase with Oil.
- Insert the dipstick into the filler neck and rotate the cap clockwise until it is tight.
- Wipe up any spilled oil.
- Recycle the used oil according to local codes.

## Servicing the Spark Plug

**Service Interval:** Every 100 hours—Inspect, clean, and adjust the spark plug; replace it if necessary.

Every 250 hours—Replace the spark plug.

Use an **NGK BPR5ES®** or **Nippondenso® W16EPR-U** spark plug or equivalent.

- Stop the engine and wait for all moving parts to stop.
- Disconnect the wire from the spark plug.
- Clean around the spark plug.
- Remove the spark plug from the cylinder head.

**Important:** Replace a cracked, fouled, or dirty spark plug. Do not clean the electrodes because grit entering the cylinder can damage the engine.

- Set the gap on the plug to 0.030 in. (0.76 mm) (Figure 29).

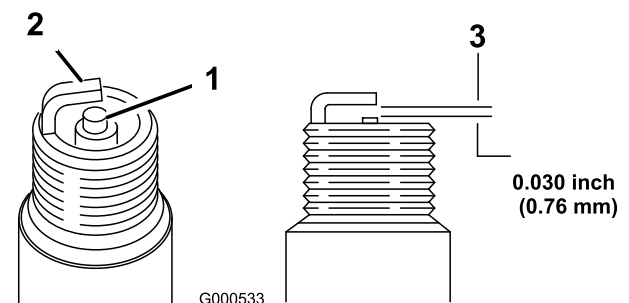

**Figure 29**

- Center electrode insulator
- Side electrode
- Air gap (not to scale)

- Carefully install the spark plug by hand (to avoid cross threading) until it is hand tight.

# Drive System Maintenance

## Adjusting the Self-propel Drive

**Service Interval:** Every 100 hours

If the lawn mower does not self-propel or has a tendency to creep forward when the control bar is more than 1-1/2 inches (3.8 cm) from the handle, adjust the wheel drive control knob on the rear of the gear box.

1. Close the door in the lawn mower housing and remove the grass bag.
2. Rotate the control knob clockwise a half turn if the lawn mower does not self-propel. If the lawn mower creeps forward, rotate the knob a half turn counterclockwise to loosen the belt (Figure 30).

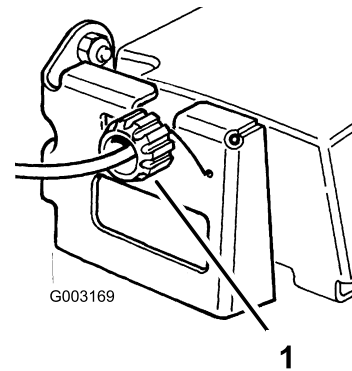
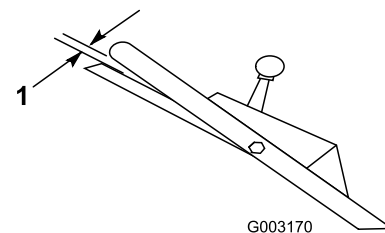

**Figure 30**

1. Control knob

3. Slowly pull the lawn mower backward while you gradually move the control bar toward the handle.

**Note:** The adjustment is correct when the rear wheels stop turning and the control bar is about one inch (2.5 cm) from the handle (Figure 31).



**Figure 31**

1. 1 inch (2.5 cm)

7. Tighten the spark plug an additional 1/2 turn if it is new; otherwise, tighten it an additional 1/8 to 1/4 turn.

**Important:** A loose spark plug can become very hot and can damage the engine; overtightening a spark plug may damage the threads in the cylinder head.

8. Connect the wire to the spark plug.

# Servicing the Wheels

## Removing the Wheels

**Service Interval:** Every 100 hours

1. Stop the engine and wait for all moving parts to stop.
2. Disconnect the wire from the spark plug.
3. Remove the bolt, the wheel spacer, and the locknut mounting the wheel to the pivot arm (Figure 32).

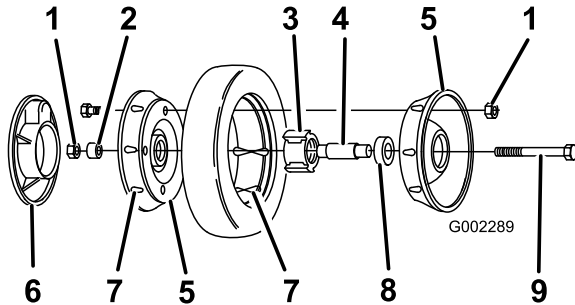

**Figure 32**

- |                         |                                     |
|-------------------------|-------------------------------------|
| 1. Locknuts             | 6. Plastic cover (rear wheels only) |
| 2. Wheel spacer         | 7. Lug                              |
| 3. Bearing/hub assembly | 8. Bearing (2)                      |
| 4. Bearing spacer       | 9. Bolt                             |
| 5. Wheel half           |                                     |

4. Separate the wheel halves from the tire by removing 4 bolts and 4 locknuts (Figure 32).

**Note:** If you remove the bearings from the bearing/hub assembly, remove them by pressing on the bearing spacer (Figure 32).

## Assembling the Wheels

1. Position the tire onto one wheel half, aligning the lugs on each (Figure 32).
2. Place the bearing/hub assembly into the center hole of the wheel half. Ensure that the legs of the hub are positioned over the flange of the hole (Figure 32).
3. Place the other wheel half onto the bearing/hub assembly, aligning the wheel and the tire lugs and the mounting holes (Figure 32).
4. Using 2 fully threaded screws or bolts (1/4-20 x 1.50 inch) and non-locking nuts, loosely secure the wheel halves together. Mount the screws or bolts in the opposing holes (Figure 32).
5. Check the alignment of all parts and tighten the bolts, alternating from side to side for a uniform fit, until the wheel halves are drawn together (Figure 32).

6. Install the 2 bolts and 2 locknuts previously removed in the remaining holes in the wheel halves and tighten. Remove the 2 long screws or bolts and replace them with 2 bolts and 2 locknuts (Figure 32).
7. Install the wheel to the pivot arm with the bolts, a spacer, and a locknut. Ensure that the spacer is positioned between the wheel hub and the pivot arm (Figure 32).

# Controls System Maintenance

## Adjusting the Blade Brake Cable

**Service Interval:** Every 100 hours

Whenever you install a new blade brake cable assembly or replace the belt, adjust the blade brake cable.

1. Stop the engine and wait for all moving parts to stop.
2. Disconnect the wire from the spark plug.
3. Loosen the cable clamp screw until the brake cable conduit slides (Figure 33).

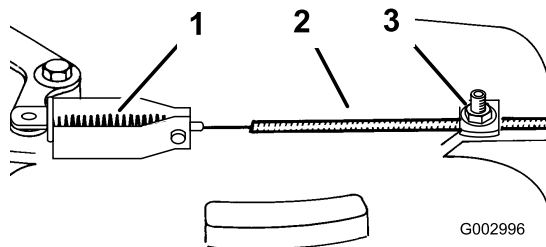

**Figure 33**

1. Spring
2. Cable conduit
3. Cable clamp screw

4. Pull the cable to the remove slack, but do not compress the spring. Tighten the cable clamp screw to lock the adjustment in place.

### **⚠ WARNING**

**Do not overtighten the blade brake cable. Overtightening the blade brake cable could cause the blade brake to come off of the brake drum. If the brake does not contact the drum, the blade will not stop rotating when you release the control bar. A rotating blade could cause serious personal injury.**

- Each time you adjust the brake cable, ensure that the brake stops the blade in 3 seconds or less.
- If the blade does not stop rotating in 3 seconds or less, bring the mower to an Authorized Service Dealer for inspection and repair.

# Blade Maintenance

## Maintaining the Blade

Always mow with a sharp blade. A sharp blade cuts cleanly and without tearing or shredding the grass blades.

1. Stop the engine and wait for all moving parts to stop.
2. Disconnect the wire from the spark plug.
3. Drain the gasoline from the fuel tank.
4. Tip the mower onto its **left** side (air cleaner up)(Figure 34).

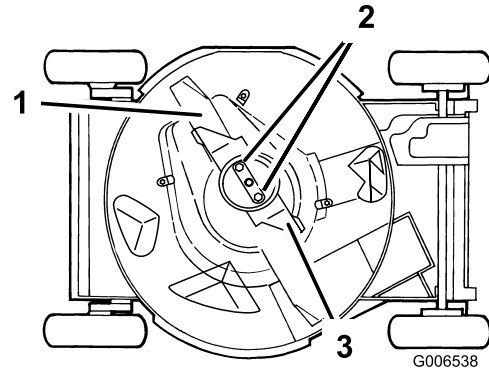

**Figure 34**

1. Blade
2. Blade nuts
3. Accelerator

## Inspecting the Blade

**Service Interval:** Before each use or daily

Carefully examine the blade for sharpness and wear, especially where the flat and the curved parts meet (Figure 35A). Because sand and abrasive material can wear away the metal that connects the flat and curved parts of the blade, check the blade before using the mower. If you notice a slot or wear (Figure 35B and C), replace the blade; refer to Removing the Blade.

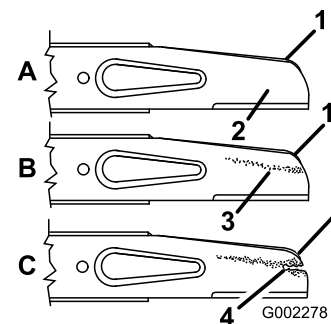

**Figure 35**

1. Sail
2. Flat part of the blade
3. Wear
4. Slot formed

**Note:** For the best performance, install a new blade before the cutting season begins. During the year, file down any small nicks to maintain the cutting edge.

## **⚠ DANGER**

A worn or damaged blade can break, and a piece of the blade could be thrown into the operator's or bystander's area, resulting in serious personal injury or death.

- Inspect the blade periodically for wear or damage.
- Replace a worn or damaged blade.

## Removing the Blade

1. Grasp the end of the blade using a rag or a thickly padded glove.
2. Remove the blade nuts, the accelerator, and the blade (Figure 35).

## Sharpening the Blade

**Service Interval:** Every 50 hours

File the top side of the blade to maintain its original cutting angle (Figure 36A) and inner cutting edge radius (Figure 36B). The blade will remain balanced if you remove the same amount of material from both cutting edges.

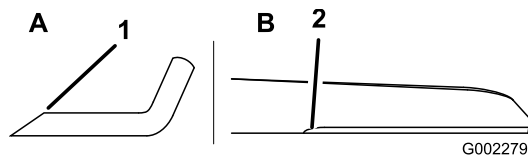
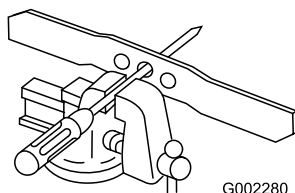

**Figure 36**

1. Sharpen at this angle only.
2. Maintain the original radius here.

## Balancing the Blade

1. Check the balance of the blade by placing the center hole of the blade over a nail or screwdriver shank clamped horizontally in a vise (Figure 37).



**Figure 37**

**Note:** You can also check the balance using a commercially manufactured blade balancer.

2. If either end of the blade rotates downward, file that end (not the cutting edge or the end near the cutting edge). The blade is properly balanced when neither end drops.

## Installing the Blade

1. Install a sharp, balanced Toro blade, the accelerator, the anti-scalp cup, and the blade nuts. The sail of the blade must point toward the top of the mower housing for proper installation. Torque the blade nuts to 15 to 27 ft-lb (20 to 37 N-m).

## **⚠ WARNING**

**Operating the mower without the accelerator in place can cause the blade to flex, bend, or break, resulting in serious injury or death to the operator or bystanders.**

**Do not operate the mower without the accelerator.**

2. Return the mower to its operating position.
3. Connect the wire to the spark plug.

# Cleaning

## Cleaning under the Mower Housing

To ensure the best performance, keep the underside of the mower housing clean. Be especially careful to keep the kickers free of debris (Figure 38).

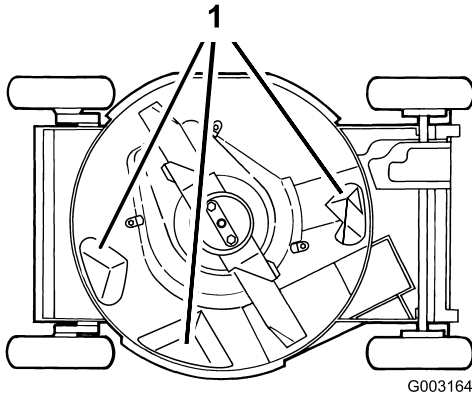

Figure 38

1. Kickers

## Washing Method

**Service Interval:** Before each use or daily

1. Position the mower on a flat concrete or asphalt surface near a garden hose.
2. Start the engine.
3. Hold the running garden hose at handle level and direct the water to flow on the ground just in front of the **right** rear tire (Figure 39).

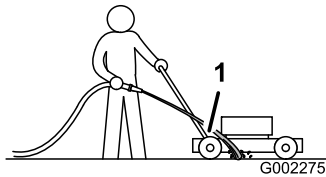

Figure 39

1. Right rear wheel

**Note:** The blade will draw in water and wash out clippings. Let the water run until you no longer see clippings being washed out from under the housing.

4. Stop the engine and wait for all moving parts to stop.
5. Turn off the water.
6. Start the mower and let it run for a few minutes to dry out the mower and its components.

## Scraping Method

If washing does not remove all debris from under the mower, scrape it clean.

1. Disconnect the wire from the spark plug.
2. Drain the fuel from the fuel tank.

### ⚠ WARNING

Tipping the mower may cause the fuel to leak from the carburetor or the fuel tank. Gasoline is extremely flammable, highly explosive, and, under certain conditions, can cause personal injury or property damage.

Avoid fuel spills by running the engine dry or by removing the gasoline with a hand pump; never siphon.

3. Tip the mower onto its **left** side.
4. Remove the dirt and grass clippings with a hardwood scraper. Avoid burrs and sharp edges.
5. Turn the mower upright.
6. Fill the fuel tank.
7. Connect the wire to the spark plug.

## Cleaning the Discharge Tunnel and Plug

**Service Interval:** Before each use or daily

Remove the plug from the discharge tunnel and clean it after each use.

Always ensure that the discharge tunnel door closes securely when you release the handle. If debris prevents the discharge door from closing securely, clean the inside of the discharge tunnel and the door thoroughly.

### ⚠ WARNING

Grass clippings and other objects can be thrown from an open discharge tunnel and cause serious injury or kill the operator or bystanders.

Never start or operate the mower unless *one* of the following is true:

- The discharge tunnel plug is locked securely in the discharge tunnel.
- The grass bag is locked in place.
- The optional side discharge chute is locked in place.
- The discharge tunnel door is locked in place.

# Cleaning under the Belt Cover

**Service Interval:** Every 50 hours—Remove grass clippings and debris from under the belt cover.

1. Stop the engine and wait for all moving parts to stop.
2. Remove the bolts that secure the belt cover (Figure 40) to the mower housing.

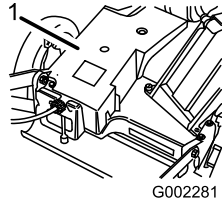

**Figure 40**

- |               |          |
|---------------|----------|
| 1. Belt cover | 2. Bolts |
|---------------|----------|

3. Lift off the cover and brush out all the debris around the belt area.
4. Install the belt cover.

# Cleaning the Blade Brake Clutch Shield

**Service Interval:** Every 50 hours

Clean the blade brake clutch shield to ensure the best performance and to prevent parts from degrading. Clean the blade brake clutch shield when you sharpen the blade because you need to remove the blade in order to remove the blade brake clutch shield.

1. Stop the engine and wait for all moving parts to stop.
2. Disconnect the wire from the spark plug.
3. Drain the gasoline from the fuel tank.
4. Tip the mower on its **left** side.

## **⚠ WARNING**

**Tipping the mower may cause the fuel to leak from the carburetor or the fuel tank. Gasoline is extremely flammable, highly explosive, and, under certain conditions, can cause personal injury or property damage.**

**Avoid fuel spills by emptying the fuel tank as directed; never siphon.**

5. Remove 2 blade nuts, the anti-scalp cup, the accelerator, and the blade (Figure 38).
6. Loosen the tabs that secure the blade brake clutch shield to the housing by loosening the nuts or the

bolts on the tabs (Figure 41). Rotate the tabs 180° to move them out of the way.

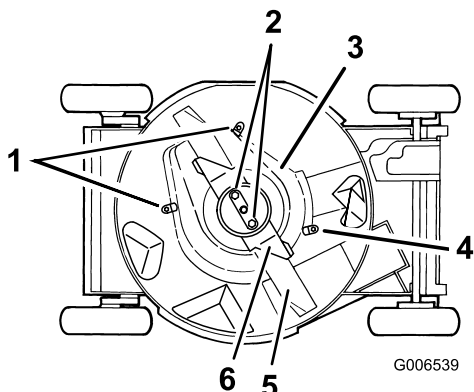

**Figure 41**

- |                              |                 |
|------------------------------|-----------------|
| 1. Tabs and nuts             | 4. Tab and bolt |
| 2. Blade nuts                | 5. Blade        |
| 3. Blade brake clutch shield | 6. Accelerator  |

7. Remove the blade brake clutch shield and brush or blow all the debris from under the shield and around the blade brake clutch system.
8. Install the blade brake clutch shield. Rotate the tabs 180° back into position. Tighten the nuts or the bolts on tabs to secure the blade brake clutch shield to the housing.
9. Install the blade, the accelerator, the anti-scalp cup, and the 2 blade nuts.
10. Return the mower to the operating position.
11. Connect the wire to the spark plug.

# Storage

To prepare the mower for off-season storage, perform the recommended maintenance procedures. Refer to Maintenance.

Store the mower in a cool, clean, dry place. Cover the mower to keep it clean and protected.

## Preparing the Fuel System

### **⚠ WARNING**

**Gasoline can vaporize if you store it over long periods of time and explode if it comes into contact with an open flame.**

- Do not store gasoline over long periods of time.
- Do not store the mower with gasoline in the fuel tank or the carburetor in an enclosure with an open flame. (For example, a furnace or a water heater pilot light.)
- Allow the engine to cool before storing it in any enclosure.

Empty the fuel tank when mowing the last time before storing the mower.

1. Run the mower until the engine stops from running out of fuel.
2. Prime the engine and start it again.
3. Allow the engine to run until it stops. When you can no longer start the engine, it is sufficiently dry.

## Preparing the Engine

1. While the engine is still warm, change the oil from the crankcase. Refer to Changing the Engine Oil.
2. Remove the spark plug.
3. Using an oil can, add about one tablespoon of oil to the crankcase through the spark plug hole.
4. Slowly rotate the engine several times, using the starter rope, to distribute the oil.
5. Install the spark plug but **do not** connect the wire to the spark plug.

## General Information

1. Clean under the mower housing. Refer to Cleaning under the Mower Housing.
2. Clean any dirt and chaff from the cylinder, cylinder head fins, and blower housing.

3. Remove grass clippings, dirt, and grime from the external parts of the engine, the shrouding, and the top of the mower housing.
4. Check the condition of the blade. Refer to Maintaining the Blade.
5. Clean the blade brake clutch shield; refer to Cleaning the Blade Brake Clutch Shield.
6. Service the air filter; refer to Servicing the Air Filter.
7. Lubricate the pivot arms; refer to Lubricating the Pivot Arms.
8. Tighten all nuts, bolts, and screws.
9. Touch up all rusted or chipped paint surfaces with paint available from an Authorized Service Dealer.

## Removing the Mower from Storage

1. Check and tighten all fasteners.
2. Remove the spark plug and spin the engine rapidly using the starter to blow excess oil from the cylinder.
3. Clean the spark plug or replace it if it is cracked, broken, or if the electrodes are worn.
4. Install the spark plug. Refer to Servicing the Spark Plug.
5. Perform any needed maintenance procedures; refer to Maintenance.
6. Fill the fuel in the fuel tank with fresh gasoline.
7. Check the engine oil level.
8. Connect the wire to the spark plug.

# Troubleshooting

Problem	Possible Cause	Corrective Action
Engine does not start	<ol style="list-style-type: none"> <li>1. The fuel tank is empty or the fuel system contains stale fuel.</li> <li>2. The throttle lever is not in the Choke position.</li> <li>3. The wire is not connected to the spark plug.</li> <li>4. The spark plug is pitted, fouled, or the gap is incorrect.</li> </ol>	<ol style="list-style-type: none"> <li>1. Drain and/or fill the fuel tank with fresh gasoline. If the problem persists, contact an Authorized Service Dealer.</li> <li>2. Move the throttle lever to the Choke position.</li> <li>3. Connect the wire to the spark plug.</li> <li>4. Check the spark plug and adjust the gap if necessary. Replace the spark plug if it is pitted, fouled, or cracked.</li> </ol>
Engine starts hard or loses power	<ol style="list-style-type: none"> <li>1. The fuel tank contains stale fuel.</li> <li>2. The fuel cap vent hole is plugged.</li> <li>3. The air filter element is dirty and is restricting the air flow.</li> <li>4. The underside of the lawn mower deck contains clippings and debris.</li> <li>5. The spark plug is pitted, fouled, or the gap is incorrect.</li> <li>6. The engine oil level is low or the oil is dirty.</li> </ol>	<ol style="list-style-type: none"> <li>1. Drain and fill the fuel tank with fresh gasoline.</li> <li>2. Clean the fuel cap vent hole or replace the fuel cap.</li> <li>3. Clean the air filter pre-cleaner and/or replace the paper air filter.</li> <li>4. Clean the underside of the lawn mower deck.</li> <li>5. Check the spark plug and adjust the gap if necessary. Replace the spark plug if it is pitted, fouled, or cracked.</li> <li>6. Check the engine oil. Change the oil if it is dirty or add oil if it is low.</li> </ol>
Engine runs rough	<ol style="list-style-type: none"> <li>1. The wire is not connected to the spark plug.</li> <li>2. The spark plug is pitted, fouled, or the gap is incorrect.</li> <li>3. The throttle lever is not in the Fast position.</li> <li>4. The air filter element is dirty and is restricting the air flow.</li> </ol>	<ol style="list-style-type: none"> <li>1. Connect the wire to the spark plug.</li> <li>2. Check the spark plug and adjust the gap if necessary. Replace the spark plug if it is pitted, fouled, or cracked.</li> <li>3. Move the throttle lever to the Fast position.</li> <li>4. Clean the air filter pre-cleaner and/or replace the paper air filter.</li> </ol>
Lawn mower or engine vibrates excessively	<ol style="list-style-type: none"> <li>1. The blade is bent or is out of balance.</li> <li>2. The blade mounting nuts are loose.</li> <li>3. The underside of the lawn mower deck contains clippings and debris.</li> <li>4. The engine mounting bolts are loose.</li> </ol>	<ol style="list-style-type: none"> <li>1. Balance the blade. If the blade is bent, replace it.</li> <li>2. Tighten the blade mounting nuts.</li> <li>3. Clean the underside of the lawn mower deck.</li> <li>4. Tighten the engine mounting bolts.</li> </ol>
Uneven cutting pattern	<ol style="list-style-type: none"> <li>1. All 4 wheels are not at the same height.</li> <li>2. The blade is dull.</li> <li>3. You are mowing in the same pattern repeatedly.</li> <li>4. The underside of the lawn mower deck contains clippings and debris.</li> </ol>	<ol style="list-style-type: none"> <li>1. Place all 4 wheels at the same height.</li> <li>2. Sharpen and balance the blade.</li> <li>3. Change the mowing pattern.</li> <li>4. Clean the underside of the lawn mower deck.</li> </ol>
Discharge chute plugs	<ol style="list-style-type: none"> <li>1. The throttle lever is not in the Fast position.</li> <li>2. The cutting height is too low.</li> <li>3. You are mowing too fast.</li> <li>4. The grass is wet.</li> <li>5. The underside of the lawn mower deck contains clippings and debris.</li> </ol>	<ol style="list-style-type: none"> <li>1. Move the throttle lever to the Fast position.</li> <li>2. Raise the cutting height.</li> <li>3. Slow down.</li> <li>4. Allow the grass to dry before mowing.</li> <li>5. Clean the underside of the lawn mower deck.</li> </ol>

<b>Problem</b>	<b>Possible Cause</b>	<b>Corrective Action</b>
Lawn mower does not self-propel	<ol style="list-style-type: none"><li data-bbox="571 111 1049 178">1. The self-propel drive cable is out of adjustment or is damaged.</li><li data-bbox="571 178 1049 256">2. There is debris under the belt cover.</li></ol>	<ol style="list-style-type: none"><li data-bbox="1049 111 1534 178">1. Adjust the self-propel drive cable. Replace the cable if necessary.</li><li data-bbox="1049 178 1534 256">2. Clean the debris from under the belt cover.</li></ol>



# The Toro Total Coverage Warranty

A Limited Warranty (see warranty periods below)

Landscape  
Contractor  
Equipment  
(LCE)

## Conditions and Products Covered

The Toro Company and its affiliate, Toro Warranty Company, pursuant to an agreement between them, jointly promise to the original purchaser to repair the Toro Products listed below if defective in materials or workmanship.

The following time periods apply from the date of purchase by the original owner:

Products	Warranty Period
All Mowers	
• Engine	See engine manufacturer's warranty <sup>1</sup>
• Battery	90 days Parts and Labor 1 year Parts only
• Belts and Tires	90 days
• Attachments	1 year
21 in. Heavy Duty Mowers	1 year commercial Use 2 years Residential Use <sup>2</sup>
Mid-Size Walk-Behind Mowers	2 years
Grand Stand™ Mowers	5 years or 1,200 hours <sup>3</sup>
• Frame	Lifetime (original owner only) <sup>4</sup>
Z Master® Z400, Z500 Mowers	4 years or 1,200 hours <sup>3</sup>
• Frame	Lifetime (original owner only) <sup>4</sup>
Z Master® G3 Mowers	5 years or 1,200 hours <sup>3</sup>
• Frame	Lifetime (original owner only) <sup>4</sup>

<sup>1</sup>Some engines used on Toro LCE Products are warranted by the engine manufacturer.

<sup>2</sup>Residential use means use of the product on the same lot as your home. Use at more than one location is considered commercial use and the commercial warranty would apply.

<sup>3</sup>Whichever occurs first.

<sup>4</sup>Lifetime Frame Warranty - If the main frame, consisting of the parts welded together to form the tractor structure that other components such as the engine are secured to, cracks or breaks in normal use, it will be repaired or replaced, at Toro's option, under warranty at no cost for parts and labor. Frame failure due to misuse or abuse and failure or repair required due to rust or corrosion are not covered.

This warranty includes the cost of parts and labor, but you must pay transportation costs.

## Instructions for Obtaining Warranty Service

If you think that your Toro Product contains a defect in materials or workmanship, follow this procedure:

1. Contact any Authorized Toro Service Dealer to arrange service at their dealership. To locate a dealer convenient to you, refer to the Yellow Pages of your telephone directory (look under "Lawn Mowers") or access our web site at [www.Toro.com](http://www.Toro.com). You may also call the numbers listed in item #3 to use the 24-hour Toro Dealer locator system.
2. Bring the product and your proof of purchase (sales receipt) to the Service Dealer. The dealer will diagnose the problem and determine if it is covered under warranty.

## Countries Other than the United States or Canada

Customers who have purchased Toro products outside the United States or Canada should contact their Toro Distributor (Dealer) to obtain guarantee policies for your country, province, or state. If for any reason you are dissatisfied with your Distributor's service or have difficulty obtaining guarantee information, contact the Toro importer. If all other remedies fail, you may contact us at Toro Warranty Company.

3. If for any reason you are dissatisfied with the Service Dealer's analysis or with the assistance provided, contact us at:

RLC Customer Care Department  
Toro Warranty Company  
8111 Lyndale Avenue South  
Bloomington, MN 55420-1196  
888-865-5676 (U.S. Customers)  
888-865-5691 (Canada customers)

## Owner Responsibilities

You must maintain your Toro Product by following the maintenance procedures described in the *Operator's Manual*. Such routine maintenance, whether performed by a dealer or by you, is at your expense.

## Items and Conditions Not Covered

There is no other express warranty except for special emission system and engine warranty coverage on some products. This express warranty does not cover the following:

- Cost of regular maintenance service or wear parts, such as filters, fuel, lubricants, tune-up parts, blade sharpening, brake and clutch adjustments.
- Any product or part which has been altered or misused and requires replacement or repair due to normal wear, accidents, or lack of proper maintenance.
- Repairs necessary due to improper fuel, contaminants in the fuel system, or failure to properly prepare the fuel system prior to any period of non-use over three months.
- Pickup and delivery charges.

## General Conditions

All repairs covered by these warranties must be performed by an Authorized Toro Service Dealer using Toro approved replacement parts.

**Neither The Toro Company nor Toro Warranty Company is liable for indirect, incidental or consequential damages in connection with the use of the Toro Products covered by this warranty, including any cost or expense of providing substitute equipment or service during reasonable periods of malfunction or non-use pending completion of repairs under this warranty.**

**All implied warranties of merchantability (that the product is fit for ordinary use) and fitness for use (that the product is fit for a particular purpose) are limited to the duration of the express warranty**

**Some states do not allow exclusions of incidental or consequential damages, or limitations on how long an implied warranty lasts, so the above exclusions and limitations may not apply to you.**

This warranty gives you specific legal rights, and you may also have other rights which vary from state to state.