



Bed Reinforcement Kit

Workman® MD Utility Vehicle

Model No. 121-9648

Installation Instructions

Loose Parts

Use the chart below to verify that all parts have been shipped.

Description	Qty.	Use
Right reinforcement bar	1	Install the kit.
Left reinforcement bar	1	
Pop rivet	20	

Installing the Kit

Note: The Drill Template Kit (121-9649) is required for this installation. Contact your authorized Toro dealer for more information.

1. Park the machine on a level surface. Set the parking brake, turn the ignition off, and remove the key.
2. Remove the steel strap holding the left end of the tailgate in place.
3. Carefully open the tailgate, drop the now free end out, and slide the tailgate to remove the right side.
4. Align the rounded edge of the tailgate drill template with the tailgate pivot and ensure that both surfaces are flush with the bed (Figure 1).

Note: Ensure that the “L” is upright for the left side of the tailgate and that the “R” is upright for the right side.

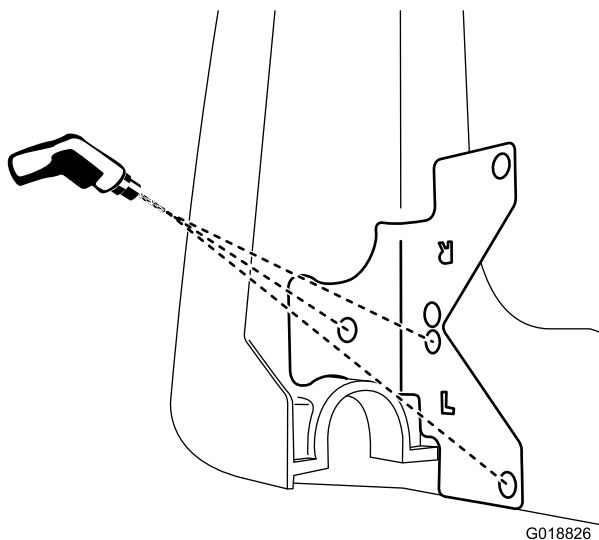

Figure 1

5. Drill 3, 8 mm (5/16 inch) holes using the template as a guide (Figure 1).
6. Slide the front end of the left reinforcement bar over the bed lift handle and tap the bar in to place.
7. Clamp the front end of the reinforcement bar to the bed near the front corner (Figure 2).

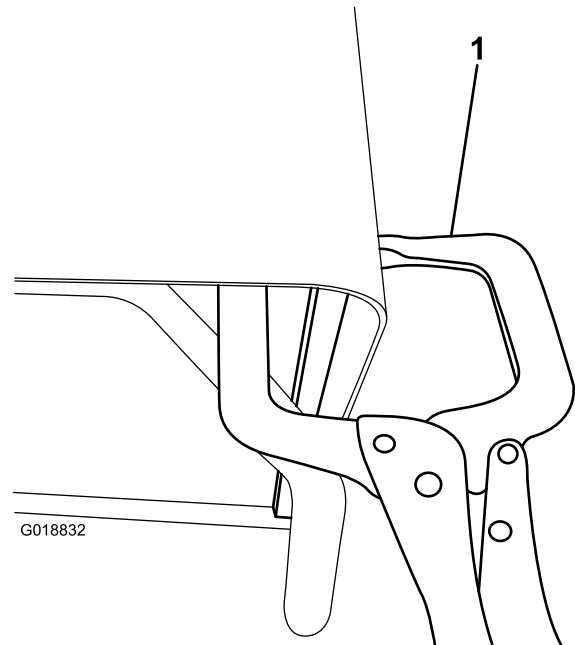

Figure 2

1. Clamp

8. Secure the back end of the reinforcement bar with 3 pop rivets in the previously drilled holes (Figure 3).



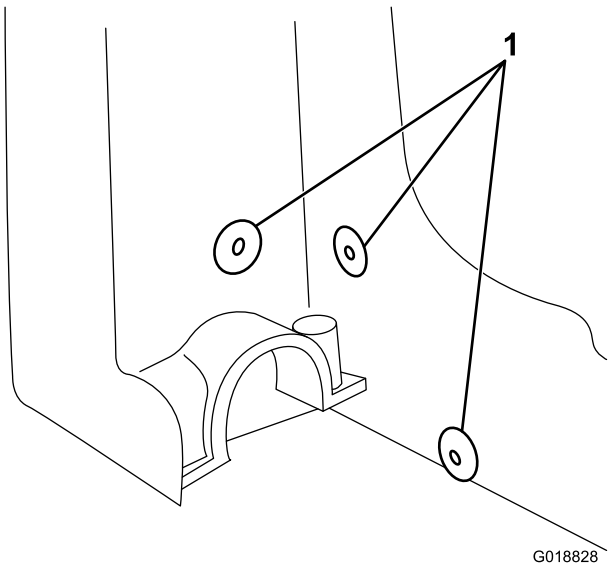

Figure 3

1. Pop rivets

9. Lift the cargo bed to gain better access to the front of the bed.
10. Using the 2 holes on the front of the reinforcement bar as a guide, drill the 4.75 mm (3/16 inch) holes from the inside of the bed (Figure 4).

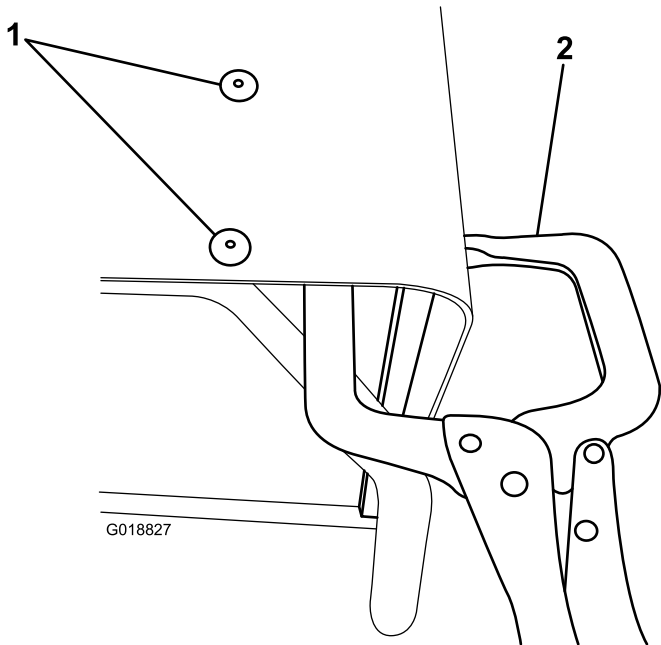

Figure 4

1. Pop rivets 2. Clamp

11. Install 2 pop rivets in the previously drilled holes (Figure 4).
12. From the inside of the bed, use the 2 holes in the reinforcement bar nearest the wheel opening as a guide and drill 4.75 mm (3/16 inch) holes (Figure 5).

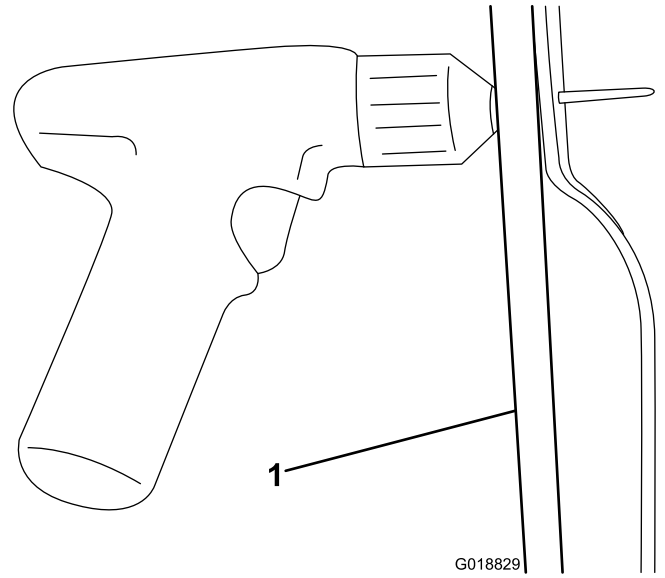

Figure 5

1. Reinforcement bar

13. Using a rivet to temporarily hold the side panel template into the front hole, line up the pointed end of the template with the bottom edge of the bed and drill an 8mm (5/16 inch) hole (Figure 6).

Important: Do not collapse the rivet while the template is in place.

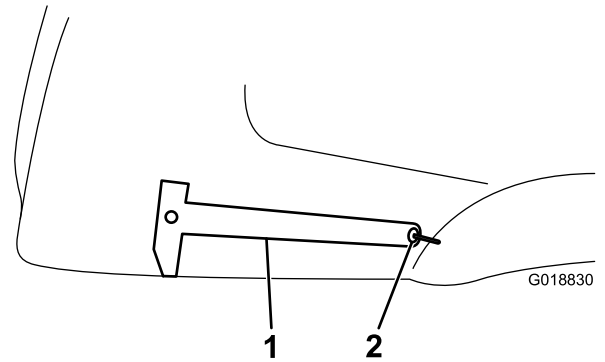
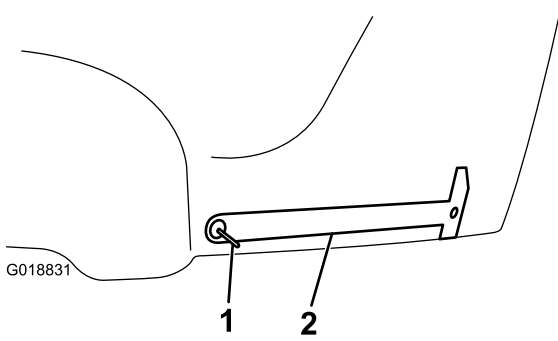

Figure 6

1. Side panel template 2. Uncollapsed pop rivet

14. Using a rivet to temporarily hold the side panel template into the rear hole, line up the square end of the template with the bottom edge of the bed and drill an 8mm (5/16 inch) hole (Figure 7).

Important: Do not collapse the rivet while the template is in place.



1. Uncollapsed pop rivet 2. Side panel template
-

15. Remove the template and install 4 pop rivets in the previously drilled holes.
16. Repeat steps 4 through 15 on the right side of the machine.
17. Install the previously removed tailgate.



Count on it.