



MODEL NO. 07050 – 50001 thru
70001 & UP (Engine Driven)
MODEL NO. 07052 – 50001 thru
70001 & Up (PTO Driven)

OPERATOR'S
MANUAL

RAKE-O-VAC®
ENGINE & PTO DRIVEN SWEEPERS

Helping you put quality into play.™

To assure maximum safety, optimum performance, and to gain knowledge of the product, it is essential that you or any other operator of the machine read and understand the contents of this manual before the engine is ever started. Pay particular attention to the SAFETY INSTRUCTIONS highlighted by this symbol—

The safety alert symbol means CAUTION, WARNING or DANGER — personal safety instruction. Failure to comply with the instruction may result in personal injury.



FOREWORD

The RAKE–O–VAC was developed to provide an efficient, trouble free and economical method of turf maintenance. The latest concepts of engineering, design and safety have been incorporated into this machine, along with the highest quality parts and workmanship. Excellent service will be derived if proper operation and maintenance practices are followed.

You know, since you have purchased the industry leader in turf maintenance excellence, that future performance and dependability are of prime importance. TORO also is concerned about future use of the machine and of safety to the user. Therefore, this manual must be read by you and those involved with the RAKE–O–VAC to make sure that safety, proper set-up, operation and maintenance procedures are followed at all times. The major sections of the manual are:

1. Safety Instructions
2. Set-Up Instructions

3. Before Operating
4. Operating Instructions

5. Maintenance

Safety, mechanical and some general information in this manual are emphasized. **DANGER, WARNING** and **CAUTION** identify safety messages. Whenever the triangle safety symbol appears, it is followed by a safety message that must be read and understood. For more details concerning safety, read the safety instructions on pages 4 and 5. **IMPORTANT** identifies special mechanical information and **NOTE** identifies general information worthy of special attention.

NOTE: All information in operator's manual is pertinent to both engine powered sweeper and P.T.O. sweeper unless specified.

OPTIONAL SPARK ARRESTER (Model 07050 only)

In some areas there are local, state or federal regulations requiring a spark arrester muffler must be used on the engine of this machine. If a spark arrester is required, contact your local Kohler Dealer.

These parts are approved by the United States Department of Agriculture and the United States Forest Service.

When the machine is used or operated on any California forest, brush or grass covered land, a properly operating spark arrester must be attached to the muffler. The operator is violating state law, Section 442 Public Resources Code if a spark arrester is not used.

If help concerning set up, operation, maintenance or safety is ever needed, contact your local Authorized TORO Distributor. In addition to genuine TORO replacement parts, the distributor also has optional equipment for the complete line of TORO turf care equipment. Keep your Toro all TORO. Buy genuine TORO parts and accessories.

TABLE OF CONTENTS

SAFETY INSTRUCTIONS	4	MAINTENANCE	16
SAFETY AND INSTRUCTION DECALS	6	Changing Engine Oil And Filter (Model 07050)	16
SPECIFICATIONS	7	Servicing Air Cleaners (Model 07050)	17
LOOSE PARTS CHART	7	Replacing Spark Plugs (Model 07050)	18
SET-UP INSTRUCTIONS	8	Removing Debris From Engine (Model 07050)	19
Remove, Activate And Charge Battery (Model 07050)	8	Replacing Fuel Filter (Model 07050)	19
Install Battery (Model 07050)	8	Changing Clutch Housing Oil (Model 07050) .	19
Mount Sweeper To Prime Mover	8	Adjusting Clutch (Model 07050)	19
Connecting Drive Shaft To Prime Mover PTO Shaft (Model 07052)	9	Changing Rubber Flap	20
Removing Sweeper From Prime Mover	9	Cleaning Blower Housing	20
BEFORE OPERATING	10	Adjusting Belts	20
Check Engine Oil (Model 07050)	10	Adjusting Drive Chain (Model 07052)	22
Check Clutch Housing Oil (Model 07050)	10	Changing Gear Box Oil (Model 07052)	23
Fill Fuel Tank (Model 07050 Only)	11	Gear Box Removal (Model 07052)	23
Check Tire Pressure	11	Locking Collar Removal	24
Transport Hooks	11	Pulley Removal	24
Adjust Reel Support Arm	11	Flex Tip Reel Removal	25
Adjust Rake Depth	12	Thatcher Installation	25
Adjust Rubber Flap	12	Flex Tip Rake Rod Or Finger Plate Replacement	25
KNOW YOUR CONTROLS	13	Flex Tip Rake Tine Replacement	26
OPERATING INSTRUCTIONS	14	Brush Half Replacement	26
Starting Instructions	14	Changing Tires	26
Stopping Instructions	14	Battery Care (Model 07050)	27
Operating Tips	14	IDENTIFICATION AND ORDERING	27
Inspection And Clean-up After Operation ...	14	Model And Serial Numbers	27
LUBRICATION	15	TORO PROMISE	Back Cover
Greasing Bearings And Bushings	15		
Oil Drive Chain (Model 07052)	16		
Oil Sweeper Jack	16		



SAFETY INSTRUCTIONS

The RAKE–O–VAC was designed and tested to offer safe service when operated and maintained properly. Although hazard control and accident prevention partially are dependent upon the design and configuration of the machine, these factors are also dependent upon the awareness, concern, and proper training of the personnel involved in the operation, transport, maintenance, and storage of the machine. Improper use or maintenance of the machine can result in injury or death. To reduce the potential for injury or death, comply with the following safety instructions.

Since the Rake–O–Vac must be towed to operate, it is extremely important that the tow tractor be carefully selected to assure the best performance and safe operation.

The tow tractor must have the proper wheel base and tread width and equipped with a roll bar and seat belt to operate safely on hilly terrain. The normal operating speed is 6 mph but will vary with terrain and debris being picked up. The maximum transport speed is 20 mph with slower speeds required on hilly terrain. Refer to tractor Operator's Manual for information or tractor service agency if you have any question on safe operation.

The brakes of the tow tractor must have the capacity to stop the Rake–O–Vac with hopper fully loaded and traveling at the maximum recommended transport speed.

The power take–off drive of the Rake–O–Vac requires a tractor with operating speeds of 540 rpm and output power of 20 hp or higher. Do not exceed the 540 rpm speed.

The Rake–O–Vac must comply with local road requirements, if transported on public roads. A Slow–moving vehicle sign has been provided. Signal lights and brakes are not provided and may be required in some areas.

WARNING: Engine exhaust contains carbon monoxide which is an odorless, deadly poison. Carbon monoxide is also known to the State of California to cause birth defects. Do not run engine indoors or in an enclosed area.

BEFORE OPERATING

1. Operate the machine only after reading and understanding the contents of this manual. A replacement manual is available by sending complete model and serial number to:

The Toro Company
8111 Lyndale Avenue South
Bloomington, Minnesota 55420–1196.

2. Never allow children to operate the machine or adults to operate it without proper instructions.

3. Become familiar with the controls and know how to stop the engine/sweeper quickly.

4. Keep all shields, safety devices and decals in place. If a shield, safety device or decal is malfunctioning, illegible, or damaged, repair or replace it before operating the machine.

5. Always wear substantial shoes. Do not operate machine while wearing sandals, tennis shoes or sneakers. Do not wear loose fitting clothing which could get caught in moving parts and cause personal injury.

6. Wearing safety glasses, safety shoes, long pants and a helmet is advisable and required by some local safety and insurance regulations.

7. Keep everyone, especially children and pets away from the areas of operation.

8. Since gasoline is highly flammable, handle it carefully.

A. Use an approved gasoline container.

B. Do not remove cap from fuel tank when engine is hot or running.

C. Do not smoke while handling gasoline.

D. Fill fuel tank outdoors and to about one inch below top of tank, (bottom of filler neck). Do not overfill.

E. Wipe up any spilled gasoline.

WHILE OPERATING

9. Exhaust fumes are hazardous and could be deadly, so do not run the engine in a confined area without adequate ventilation.

10. This product may exceed noise levels of 85 dB(A) at the operator position. Ear protectors are recommended, for prolonged exposure, to reduce the potential of permanent hearing damage.

11. Never carry passengers on prime mover or allow anyone to ride on sweeper.

12. Disengage clutch before starting sweeper engine.

13. Using the machine demands attention. To prevent tipping or loss of control:

A. Use extreme caution around ditches, creeks or other hazards.

B. Watch for holes or other hidden hazards.

C. Use caution when operating machine on a steep slope. Reduce speed when making sharp turns or when turning on hillsides.

D. Avoid sudden stops and starts.

E. Before backing up, look to the rear and assure no one is behind the machine.

F. Watch out for traffic when near or crossing roads. Always yield the right of way.



SAFETY INSTRUCTIONS

14. Before leaving operator position:

- A.** Shift into neutral, stop prime mover and engage parking brake.
- B.** Shut engine off and wait for all movement to stop. The impeller may momentarily turn after other components have stopped. Use extreme caution when removing cover from blower housing.
- C.** Disengage and lower sweeper implement.
- D.** Shut sweeper engine off.
- E.** Disengage P.T.O.
- F.** Take precautions to prevent accidental starts, rolling away, etc.

15. Do not step over P.T.O. shaft to get to other side of machine. Walk around sweeper.

16. Never get on or off prime mover with P.T.O. shaft engaged.

17. If prime mover or sweeper ever vibrate abnormally, stop immediately, turn engine off, wait for all motion to stop and inspect for damage. Repair all damage before commencing operation.

18. Whenever machine is left unattended, be sure engine is stopped, implement is lowered and key is removed from ignition switch.

19. Shut sweeper blower off when dumping contents of hopper. Always stand to extreme right or left side of hopper when opening tailgate.

20. Park on a level surface, empty hopper and block wheels before removing sweeper from prime mover.

MAINTENANCE

21. Disengage power to sweeper implement and stop engine before servicing or making adjustments.

22. Disengage power to sweeper implement and stop engine when transporting or not in use.

23. To make sure entire machine is in good condition, keep all nuts, bolts and screws properly tightened.

24. If major repairs are ever needed or assistance is required, contact an Authorized TORO Distributor.

25. To reduce potential fire hazard, keep the engine area free of excessive grease, grass, leaves and accumulation of dirt.

26. If the engine must be running to perform a maintenance adjustment, keep hands, feet, clothing, and any parts of the body away from the engine and any moving parts. Keep everyone away.

27. Do not overspeed engine by changing governor settings. To assure safety and accuracy, have an Authorized Toro Distributor check maximum engine speed with a tachometer. P.T.O. driven machines must not exceed 540 R.P.M.

28. Engine must be shut off before checking oil or adding oil to the crankcase.

29. Check prime mover brakes periodically to be sure brakes, when applied, will hold firmly. Also, check to make sure all safety equipment is functioning properly.

30. To be sure of optimum performance and safety, always purchase genuine TORO replacement parts and accessories. Replacement parts and accessories made by other manufacturers could be dangerous. Such use could void the product warranty of The Toro Company.



SAFETY AND INSTRUCTION DECALS

The following safety and instruction decals are installed on the machine. If any become damaged or illegible, replace them. Decal part numbers are listed below and in the parts catalog. Order replacements from your Authorized Toro Distributor.



ON LEFT SIDE OF BLOWER
(Part No. 67-5360)



ON LEFT SIDE OF HOPPER
(Part No. 13-7430)



ON REAR OF HOPPER
(Part No. 13-6760)



ON LEFT SIDE OF BLOWER
(Part No. 92-8309)



ON BATTERY COVER
(Part No. 61-5950)
(Model 07050 only)



ON DRIVE SHAFT
(Part No. 92-1582)
Model 07052 only)

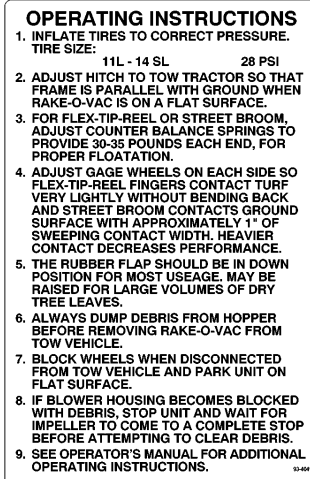

ON RIGHT SIDE OF BLOWER
(Part No. 92-4041)



ON FUEL TANK
(Part No. 92-1582)
(Model 07050 only)



ON FRONT OF BLOWER
(Part No. 13-6410)



ON DRIVE SHAFT
(Part No. 92-1581)
Model 07052 only)



ON FRONT OF BLOWER
(Part No. 93-7307)

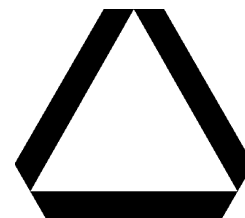

ON REAR OF HOPPER
(Part No. 13-2930)
(When required for transporting on public roads)

SPECIFICATIONS

Machine Drive:

(Model 07050): Kohler, 4 cycle air cooled 22 H.P. engine @ 2800 rpm, 38.1 cu. in. (624 cc) displacement. 2 qt. oil capacity. Mechanical fuel pump. Gas tank capacity is 4 gallons.

(Model 07052): Powered by Power Take Off drive from prime mover—540 RPM.

Frame: All welded structural rectangular 11 ga. tubing.

Hitch (Model 07050) Pin—type, 3/4” dia. vertically adjustable in 1” increments.

Hitch (Model 07052) Pin—type, 3/4” dia. three vertical positions for tractor hitches ranging from 7–1/4” to 17–1/4” in height.

Fan: Centrifugal type—double inlet; 4 blade, 16” wide, 23–14” diameter, 3/16” thick, high tensile steel. Shaft mounted in self—aligning, sealed ball bearings. Blower inlet area is 286 sq. in., blower discharge area is 255 sq. in. Twin fan hood construction for uniform air distribution: 4–1/2” deep x 63” wide (inlet area—283 sq. in.); variable position from weighted rubber flap.

Fan Drive (Model 07050) – Banded double, B–80 drive belt direct from drive shaft to fan impeller drive shaft with 3.6 P. diameter (driver) pulley, fan with 7.4 P. diameter (driven) pulley. Fan impeller runs at 1580 R.P.M. (tip speed 9100 ft./min.) at 3250 engine R.P.M.

Fan Drive (Model 07052) – Banded double, B–83 drive belt direct from drive shaft to fan impeller drive shaft with 9.4 P. diameter (driver) pulley, fan with 4.6 P. diameter (driven) pulley. Fan impeller runs at 1490 R.P.M. (tip speed 9100 ft./min.) with 540 PTO R.P.M.

Hopper: 5–3/4 cu. yd. volume; 18 gauge top section with 16 gauge bottom section—rib reinforced; full width self cleaning semi—automatic dumping.

Flex Tip Reel: Forward spinning with 6 rows of teeth. All steel construction with replaceable 3/16” extruded

nylon teeth; each row containing 11 individually spring—loaded flexible sets, 552 teeth total; 18–3/4” dia., 612 wide; 1–1/8” shaft set in self—aligning sealed bearings. Reel supported by adjustable counter balance springs and adjustable gauge wheels. Gauge wheels are steel construction with non—scuffing rubber tires and sealed ball bearings; infinitely adjustable vertically.

Flex Tip Reel Drive (Model 07050) – Banded double, B–53 drive belt from 3.6” P. diameter engine pulley to 11” P. diameter jackshaft pulley; Banded (4) 3V cross section belt from 2.76 P diameter jack shaft (driver) pulley to 10.55 P diameter flex tip reel (driven) pulley. Flex tip runs at 275 R.P.M. (tip speed 1355 ft./min.) at 3250 engine R.P.M.

Flex Tip Reel Drive (Model 07052) – #60 roller chain from 40 tooth side shaft sprocket to 29 tooth jackshaft sprocket. Banded (4) 3V cross section belt from 2.76 P diameter jack shaft (driver) pulley to 10.55 P diameter flex tip reel (driven) pulley. Flex tip runs at 260 R.P.M. (tip speed 1,230 ft./min.) with 540 R.P.M.

Dimensions:

Width	85–1/2”
Height:	79–1/2”
Length	13’ 3” (Model 07050) 14’ (Model 07052)
Empty Weight:	2160 lb. (Model 07050) 1980 lb. (Model 07052)

Optional Equipment:

- Hard Surface Brush Kit, Model No. 07162
- Thatching Reel Kit, Model No. 07178
- Flex Tip Reel, Model No. 07164
- Spark Arrester Muffler, Kohler No. 1218902, Contact Your Local Kohler Dealer.

LOOSE PARTS CHART

Note: Use this chart as a checklist to ensure all parts necessary for assembly have been shipped. If any of these parts are missing, total set—up cannot be completed.

PART DESCRIPTION	QTY.	WHERE USED
Operator’s Manual	1	Read before operating machine. Fill out and return to Toro.
Parts Catalog	1	
Engine Operator’s Manual	1	
Registration Card	1	

Specifications and design subject to change without notice.

SET UP INSTRUCTIONS

REMOVE, ACTIVATE AND CHARGE BATTERY (Model 07050 only)

1. If Battery is not filled with electrolyte or activated, bulk electrolyte with 1.260 specific gravity must be purchased from a local battery supply outlet and added to battery.

CAUTION

Wear safety goggles and rubber gloves when working with electrolyte. Charge the battery in a well ventilated place so gasses produced while charging can dissipate. Since the gases are explosive, keep open flames and electrical spark away from the battery; do not smoke. Nausea may result if the gases are inhaled. Unplug charger from electrical outlet before connecting to or disconnecting charger leads from battery posts.

2. Unhook springs from battery cover, remove cover and lift battery out of battery box.

3. Remove filler caps from battery and slowly fill each cell until electrolyte is up to fill line.

4. Replace filler caps and connect a 3 to 4 amp battery charger to the battery posts. Charge the battery at a rate of 3 to 4 amperes for 4 to 8 hours.

5. When battery is charged, disconnect charger from electrical outlet and battery posts. Allow battery to sit for 5 to 10 minutes before proceeding to next step.

6. Remove filler caps and slowly add electrolyte to each cell until level is up fill line. Install filler caps.

IMPORTANT: Do not overfill battery. Electrolyte will overflow onto other parts of the machine and severe corrosion and deterioration will result.

INSTALL BATTERY (Model 07050 only)

1. Slide the battery into battery box with the terminals to the inside.

2. Attach the negative cable (wire from engine block) to the negative (-) terminal of the battery.

3. Attach the positive cable (wire from ignition switch) to the positive (+) terminal.

4. Coat the terminals and mounting fasteners with petroleum jelly to prevent corrosion.

5. Install battery cover and secure with springs.

WARNING

Connecting cables to the wrong post could result in personal injury and/or damage to the electrical system. Make sure battery or cables do not interfere or rub on any moving or hot parts.

MOUNT SWEEPER TO PRIME MOVER (Fig. 1 & 2)

To assure proper debris pickup, make sure sweeper frame is parallel with the ground.

1. Position sweeper on a flat, level surface.
2. Insert sweeper jack caster wheel onto sweeper end of jack tube.
3. Adjust sweeper jack so distance from top of frame to ground is approximately 23–1/2”.

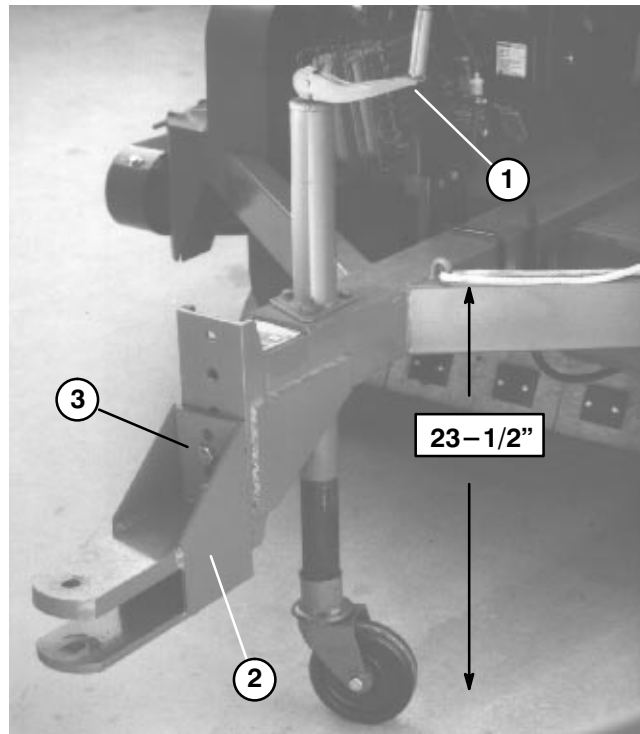

Figure 1

1. Sweeper jack
2. Hitch tongue (Model 07050)
3. Adjusting screws

4. Back prime mover up to sweeper.

5. Adjust sweeper hitch tongue to same level as hitch of prime mover as follows:

Model 07050 –

A. Remove capscrews and locknuts securing hitch tongue to frame (Fig. 1).

B. Raise or lower hitch tongue to position approximately level with prime mover hitch and secure with (2) capscrews and locknuts.

SET UP INSTRUCTIONS

Model 07052

A. Remove front and rear capscrews and locknuts securing hitch tongue to frame (Fig. 2).

B. Raise or lower hitch tongue to position it approximately level with prime move hitch and secure with (2) capscrews and locknuts. The main frame should be parallel with the ground surface about 23–1/2" when attached to tractor.

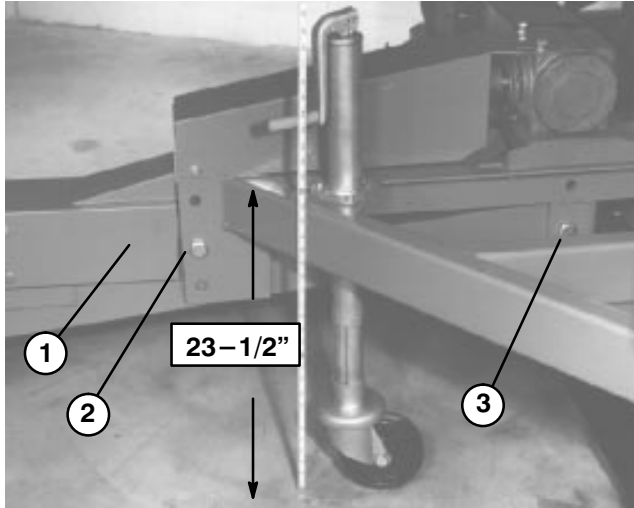

Figure 2

1. Hitch tongue (Model 07052)
2. Front adjustment capscrew
3. Rear adjustment capscrew

6. Secure sweeper hitch tongue to prime mover hitch with hitch pin and hair pin cotter.

7. Raise sweeper jack caster wheel tube up to frame and fold handle down.

8. Store caster wheel in compartment on left side of machine in front of hopper.

IMPORTANT: After first ten hours of operation, re-tighten capscrews and locknuts securing hitch tongue to sweeper.

CONNECTING DRIVE SHAFT TO PRIME MOVER PTO SHAFT (Model 07052 only)

IMPORTANT: Mating tractor must have the following dimensions. Do not operate sweeper with tractor of different dimensions.

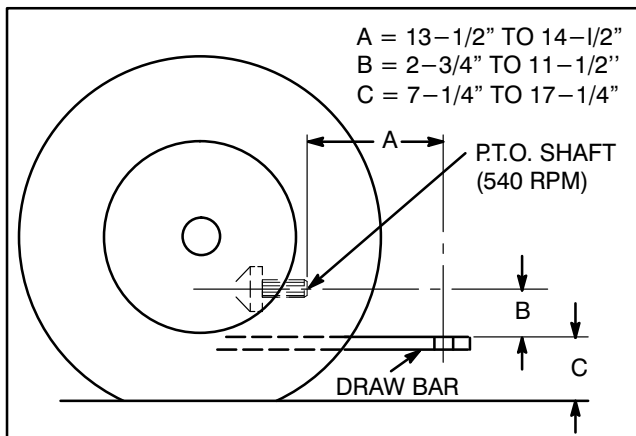

Figure 3

IMPORTANT: The distance ("A" Figure 3) between the hole in the tractor hitch and the point where the drive shaft coupler attaches to the prime mover, P.T.O. shaft must be 14" plus or minus 1/2". If 14" is not evident, an adjustment to the tractor hitch must be made before operating sweeper.



WARNING

If "B" dimension (Fig. 3) is less than 3", extreme caution must be used when tractor and sweeper unit crests tops of steep hills.

1. Attach drive shaft quick disconnect to P.T.O. shaft of prime mover.

IMPORTANT: A shield should be provided on tractor to cover drive shaft universal joint. Do not operate drive shaft without this shield in place.

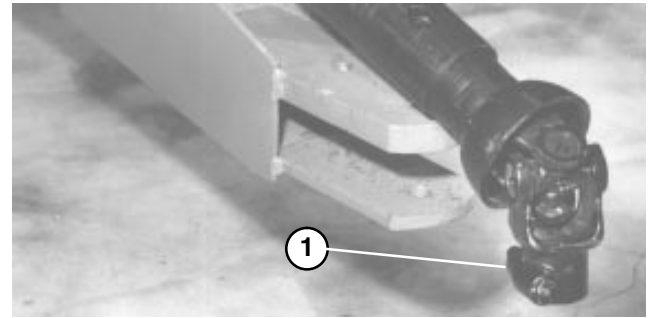

Figure 4

1. Drive shaft quick coupler



WARNING

This sweeper is designed for a 540 RPM P.T.O. shaft only. Do not operate with 1000 P.T.O. tractor.

REMOVING SWEEPER FROM PRIME MOVER



WARNING

Always empty sweeper hopper before disconnecting hopper from prime mover or sweeper may tip backwards and cause injury.

1. Park sweeper on a level surface and block wheels.
2. On Model 07052 only, disconnect drive shaft quick coupler from prime mover PTO shaft.
3. Insert castor wheel onto jack tube.
4. Raise sweeper jack handle and lower caster wheel to ground.
5. Continue to raise sweeper with jack until hair pin cotter and hitch pin can be removed from hitch.

BEFORE OPERATING



CAUTION

Before servicing or making adjustments to the machine, stop engine(s), disengage clutch and disconnect PTO (If so equipped) from prime mover.

CHECK ENGINE OIL (Fig. 5 & 6) (Model 07050 only)

The engine is shipped with approximately 2 quarts (w/filter) of oil in the crankcase; however, level of oil must be checked before and after the engine is first started.

1. Position machine on a level surface.
2. Remove dipstick and wipe it with a clean rag. Insert dipstick into tube and make sure it is seated fully. Remove dipstick from tube and check level of oil. If oil level is low, remove filler cap and add enough oil to raise level to "FULL" mark on dipstick.



Figure 5
1. Dipstick

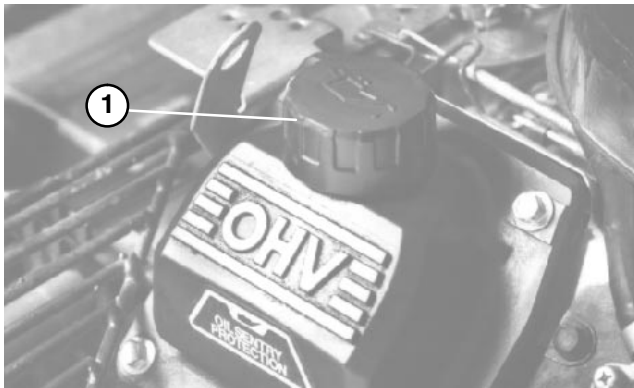

Figure 6
1. Filler cap

3. The engine uses any high-quality detergent oil having the American Petroleum Institute -API- "service classification" SF, SG or SH. Oil viscosity (weight) is selected according to the anticipated ambient temperature.

Temperature / viscosity recommendations are:

A. Above 0°F (-20°C) – Use 10W-30 or 10W-40.

B. Below 32°F (0°C) – Use 5W-20 or 5W-30.

4. Pour oil into fill opening until the oil level is up to the "FULL" mark on the dipstick. Add the oil slowly and check the level often during this process. DO NOT OVERFILL

IMPORTANT: Check level of oil every 8 operating hours or daily. Initially, change oil after the first 5 hours of operation; thereafter, under normal conditions, change oil every 100 hours and filter every 200 hours. However, change oil more frequently when engine is operated in extremely dusty or dirty conditions.

5. Install the dipstick firmly in place.

CHECK CLUTCH HOUSING OIL (Model 07050 only) (Fig. 7)

The clutch housing uses any high-quality detergent oil having the American Petroleum Institute -API- "service classification" SE, SF, SG or SH. Recommended viscosity (weight) is SAE 30.

1. Position machine on a level surface.
2. Remove oil level plug on side of clutch housing.

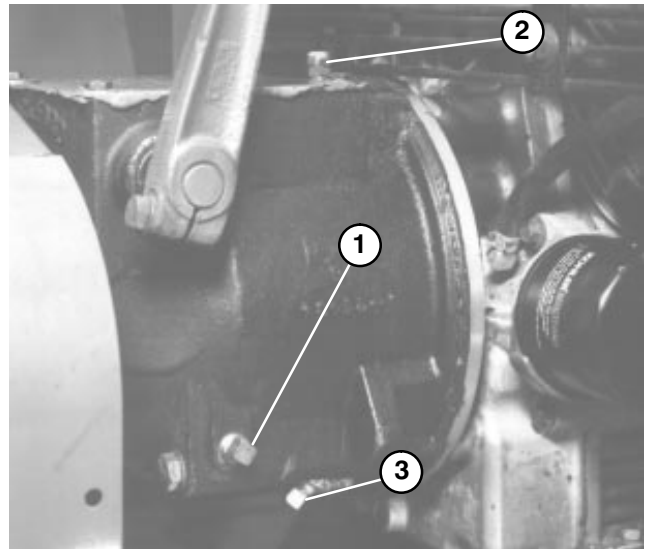

Figure 7
1. Oil level plug
2. Filler/breather plug
3. Drain plug

3. If oil drips from hole, there is enough oil in clutch housing. Replace plug.
4. If oil does not drip from hole, oil must be added to clutch housing. Do not replace plug.
5. Remove filler plug from top of clutch housing.
6. Add enough oil to clutch housing until it drips out oil level hole.
7. Reinstall plugs.

BEFORE OPERATING

FILL FUEL TANK

(Model 07050 only)

Fuel tank capacity is approximately 4 gallons.



DANGER

Because gasoline is flammable, caution must be used when storing or handling it. Do not fill fuel tank while engine is running, hot or when machine is in an enclosed area. Vapors may build up and be ignited by a spark or flame source many feet away. **DO NOT SMOKE** while filling the fuel tank to prevent the possibility of an explosion. Always fill fuel tank outside and wipe up any spilled gasoline before starting engine. Use a funnel or spout to prevent spilling gasoline, and fill tank no higher than one inch below top of tank, (bottom of filler neck). **DO NOT OVER FILL.** Store gasoline in a clean safety approved container and keep the cap on the container. Keep gasoline in a cool, well-ventilated place; never in an enclosed area such as a hot storage shed. To assure volatility, do not buy more than a 30 day supply of gasoline. Gasoline is a fuel for internal combustion engines; therefore do not use it for any other purpose. Since many children like the smell of gas, keep it out of their reach because the fumes are explosive and dangerous to inhale.

THE TORO COMPANY STRONGLY RECOMMENDS THE USE OF FRESH, CLEAN, **UNLEADED** REGULAR GRADE GASOLINE IN TORO GASOLINE POWERED PRODUCTS. UNLEADED GASOLINE BURNS CLEANER, EXTENDS ENGINE LIFE, AND PROMOTES GOOD STARTING BY REDUCING THE BUILD-UP OF COMBUSTION CHAMBER DEPOSITS. LEADED GASOLINE CAN BE USED IF UNLEADED IS NOT AVAILABLE.

NOTE: NEVER USE METHANOL, GASOLINE CONTAINING METHANOL, GASOLINE CONTAINING MORE THAN 10% ETHANOL, GASOLINE ADDITIVES, PREMIUM GASOLINE OR WHITE GAS BECAUSE ENGINE FUEL SYSTEM DAMAGE COULD RESULT.

1. Clean area around fuel tank cap.
2. Remove fuel tank cap.
3. Fill tank to about one inch below top of tank, (bottom of filler neck). **DO NOT OVERFILL.** Then install cap.

4. Wipe up any fuel that may have spilled to prevent a fire hazard.

CHECK TIRE PRESSURE

Check tire pressure daily to assure proper level.

Correct tire pressure is 28 psi.

TRANSPORT HOOKS (Fig. 8)

1. Lift each end of reel and remove transport hooks before operating machine.

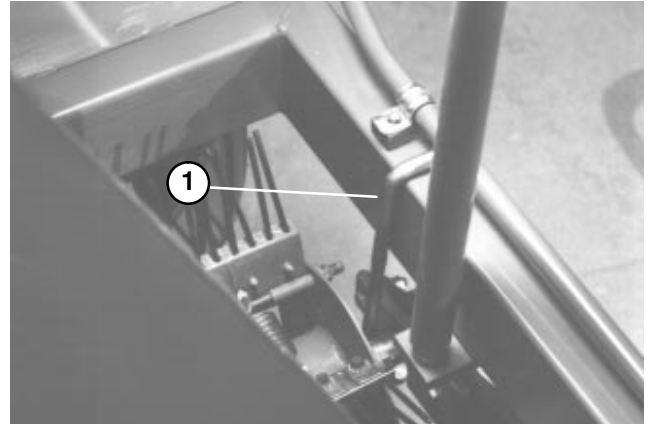

Figure 8

1. Transport hook

2. When transporting sweeper from one location to another, support flex tip reel, broom or thatching reel with transport hooks.

ADJUST REEL SUPPORT ARM (Fig. 9)

When machine is operated, gauge wheel should ride over the turf evenly. If reel support arm has a tendency to bounce, spring setting is too tight. If gauge wheel scars turf, spring setting is too light.

To adjust reel support arm:

1. Pull rake lever rearward to lower flex tip reel or broom.

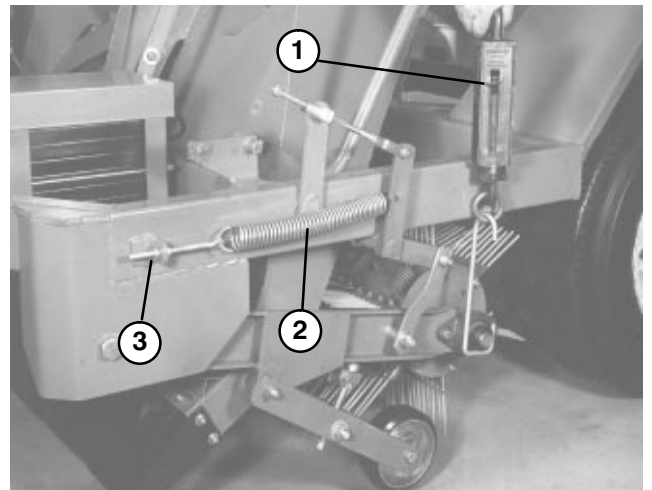

Figure 9

1. Spring scale
2. Counterbalance spring
3. Adjustment screw

BEFORE OPERATING

2. Position a spring scale on transport hook and lift up. Tension necessary to lift gauge wheel off ground should be 30–50 lbs.

3. If tension is not 30–50 lbs., adjustment is made by tightening or loosening adjustment screw on counterbalance spring.

4. Perform this procedure on both sides of sweeper.

NOTE: Because of added weight of drive components, the R.H. spring will require a tighter setting than the L.H. spring.

ADJUST RAKE DEPTH (Fig. 10 & 11)

Flex tip reel should be adjusted so rake tips slightly touch surface but do not penetrate turf. If rake tips penetrate turf, improper debris pickup could result.

1. Position sweeper on a level surface.
2. Loosen locknut on depth adjustment bolt so it can be turned.

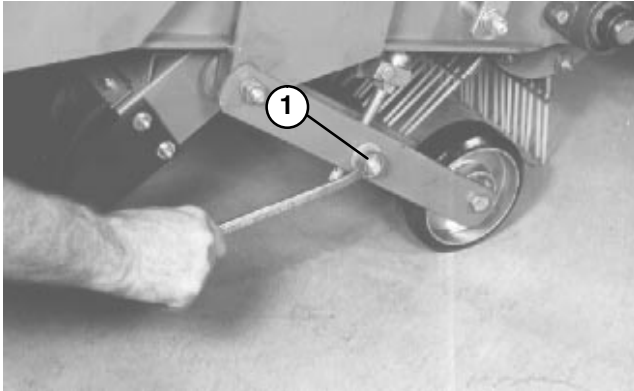

Figure 10

1. Locknut

3. Turn depth adjustment bolt until rake slightly contacts top of turf grass. If a broom is installed, slight contact should be made with surface. When broom is operating, the contact width surface should be about 1" wide across entire length of broom.

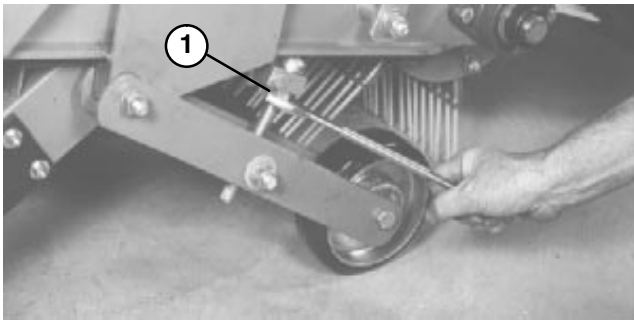

Figure 11

1. Depth adjusting bolt

4. Repeat procedure on opposite side of machine.

5. Retighten adjustment lock nut.

ADJUST RUBBER FLAP (Fig. 12 & 13)

For best debris pick up results, metal portion of front flap should be vertical to ground.

1. Move flat lever forward to lower flat.

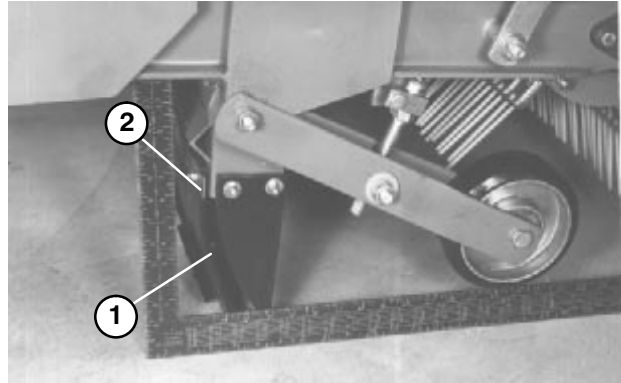

Figure 12

1. Rubber flap
2. Metal edge

2. Loosen jam nut on top of stop and rotate adjustment bolt up or down until flap is vertical to ground.

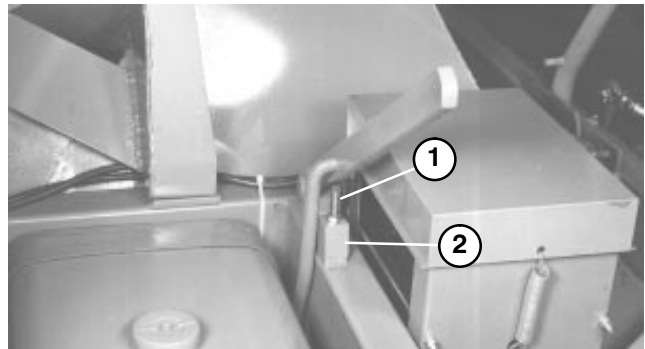

Figure 13

1. Adjustment bolt
2. Stop

3. Tighten jam nut to secure adjustment.

NOTE: Flap may be positioned in raised position when picking up large amounts of leaves.

KNOW YOUR CONTROLS

Flap Lever (Fig. 14) – Move lever downward to engaged position and upward for disengaged position. Move lever to upward position when transporting machine.

Reel Lever (Fig. 14) – Push lever forward to raise flex tip reel. To lower flex reel, push lever forward until catch releases, then push to rear until lever hits STOP. Move lever to raised position when sweeper is not in operation, when storing machine or when transporting machine.

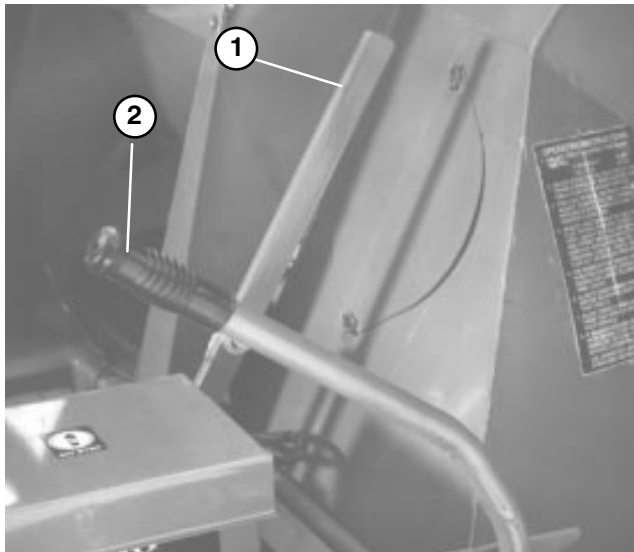

Figure 14
1. Flap lever
2. Reel lever

Clutch Handle (Model 07050 only) (Fig. 15) – The clutch handle is located on the clutch housing. Push outward on clutch handle to engage and inward to disengage.

IMPORTANT: Move sweeper as quickly as possible after lowering reel lever and engaging clutch lever to prevent turf damage.

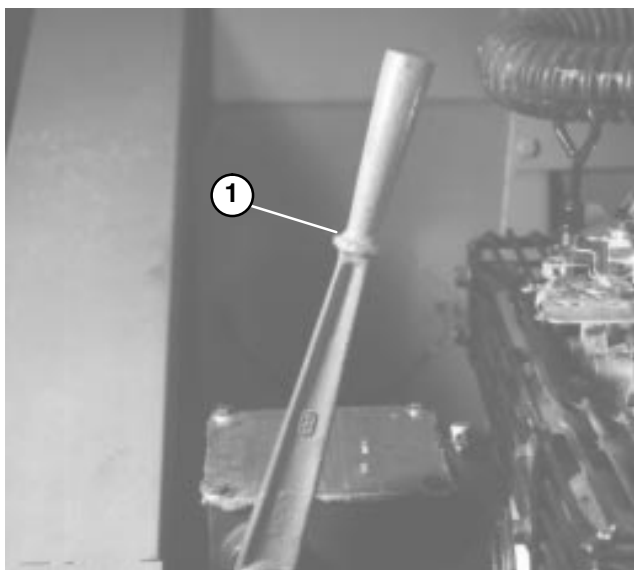

Figure 15
1. Clutch handle

Choke Control (Model 07050 only) (Fig. 16) – To start a cold engine, close carburetor choke by pulling choke control outward to the “CLOSED” position. After engine starts, regulate choke to keep engine running smoothly. As soon as possible, open the choke by pushing inward to the “OPEN” position. Starting a warm engine requires little or no choking.

Ignition Switch (Model 07050 only) (Fig. 16) – The ignition switch, which is used to start and stop the engine, has three positions: OFF, RUN and START. Rotate key clockwise — START position — to engage starter motor. Release key when engine starts. The key will move automatically to the ON position. To shut engine off, rotate key counterclockwise to the OFF position.

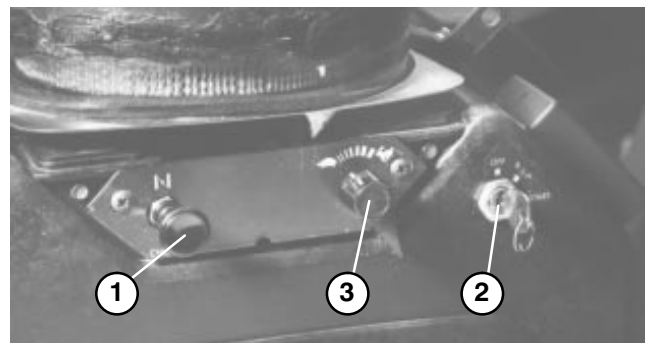

Figure 16
1. Choke control
2. Ignition switch
3. Throttle control

Throttle Control (Model 07050 only) (Fig. 16) – Throttle is used to operate engine at various speeds. Rotating throttle clockwise increases engine speed — FAST; counterclockwise decreases engine speed — SLOW.

Tailgate Latch Rope (Fig. 17) – Pull rope to unlatch tailgate when emptying hopper.

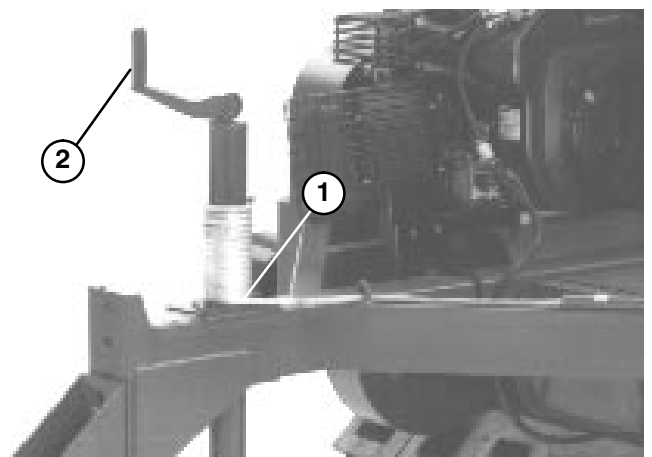

Figure 17
1. Tailgate latch rope
2. Jack handle

OPERATING INSTRUCTIONS

STARTING INSTRUCTIONS (Engine Driven)

1. Place all controls in disengaged or off position.
2. Rotate throttle control midway between SLOW and FAST position.
3. Pull choke out to ON position.

NOTE: Choke not required when starting a warm engine.

4. Insert key into ignition switch and rotate it clockwise to start the engine. Release key when engine starts. Regulate the choke to keep engine running smoothly.

IMPORTANT: To prevent overheating of the starter motor, do not engage starter longer than 10 seconds. After 10 seconds of continuous cranking, wait 60 seconds before engaging starter motor again.

5. Move throttle control to desired engine speed.
6. Pull flap lever as far forward as possible.
7. Push rake lever to the rear as far as possible.
8. Engage rake by engaging clutch handle.

NOTE: Do not allow sweeper to stand still with rake engaged as turf damage may occur.

STOPPING INSTRUCTIONS

1. Disengage power to rake by disengaging clutch lever.
2. Move throttle to "SLOW" position.
3. Move ignition switch to "OFF" position. Remove key from switch to prevent accidental starting.

IMPORTANT: To stop sweeper in an emergency, move ignition switch to "OFF" position.

STARTING INSTRUCTIONS (PTO Driven)

1. Read and understand all operating procedures in tow tractor operator's manual. Contact tow tractor dealer or manufacturer regarding any questions you have about safety or operation.
2. Make sure all P.T.O. guards are installed and operating properly.
3. Know how to stop tow tractor and sweeper in an emergency.
4. Pull flap lever as far forward as possible.
5. Push rake lever to the rear as far as possible.
6. Engage rake by engaging clutch handle.

NOTE: Do not allow sweeper to stand still with rake engaged as turf damage may occur.

OPERATING TIPS

Before starting to sweep, survey area to determine the best direction to sweep.

NOTE: To maintain a straight line when sweeping, sight of an object in the foreground.

Always try to make a long, continuous run with a slight overlap on the return run.

On turf areas, the flex tip reel will pick up twigs, clippings, leaves, pine needles and cones, small debris (beverage cans, small bottles, paper plates, etc.).

The rake teeth are made of flexible nylon and easily changed. To prevent damage, the rake is protected from solid obstructions by spring action. The nylon teeth will not mar bronze, stone markers, sidewalks or pavement.

Because of its unique design, the sweeper also grooms the turf. The flex tip reel combs through and lifts grass for a uniform cut when mowed. As it cleans, the light scarifying action increase water and pesticide penetration, thus reducing the need for renovation.

IMPORTANT: Do not make sharp turns when using the thatching reel as damage to turf may occur.

IMPORTANT: Do not operate sweeper while reel is turning and in the raised position. Damage to the rake and tires may result if teeth come in contact with tires.

CAUTION: This product may exceed noise levels of 85 dB(A) at the operator position. Ear protectors are recommended, for prolonged exposure, to reduce the potential of permanent hearing damage.

To empty hopper, pull tailgate latch rope.

INSPECTION AND CLEANUP AFTER OPERATION

When sweeping has been completed, thoroughly clean and wash the machine. Air dry hopper. After cleaning, it is recommended that the machine be inspected for possible damage to mechanical components and blower. These procedures will assure that the machine will perform satisfactorily during next sweeping operation.

IMPORTANT: When towing sweeper for long distances, fasten gauge wheel arm securely to sweeper frame with transport hooks. Should gauge wheel arm fall to ground, damage to sweeper may occur.

LUBRICATION



CAUTION

Before servicing or making adjustments to the machine, disengage clutch, stop engine and wait for all moving parts to stop.

GREASING BEARINGS AND BUSHINGS

The Rake-O-Vac has grease fittings that must be lubricated regularly with No. 2 General Purpose Lithium Base Grease. Lubricate bearings after every 30 hours of operation or whenever machine is washed with water. Bearings and bushings must be lubricated daily when operating conditions are extremely dusty and dirty. Dusty and dirty operating conditions could cause dirt to get into the bearings and bushings, resulting in accelerated wear. The grease fittings that must be lubricated are the gauge wheel bearings (2) (Fig. 18); reel shaft bearings (2) (Fig. 18); impeller shaft bearings (2) (Fig. 19); Jackshaft bearings (2) (Fig. 20) left and right trailing arms (1 ea.) (Fig. 20) front and rear drive shafts (6) (Model 07052 only) (Fig. 21 & 22).

1. Wipe grease fittings clean so foreign matter cannot be forced into the bearing or bushing.
2. Pump grease into the bearing or bushing.
3. Wipe up excess grease.

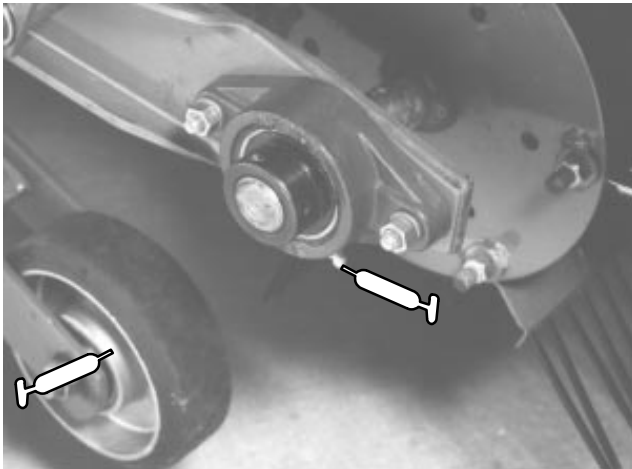

Figure 18

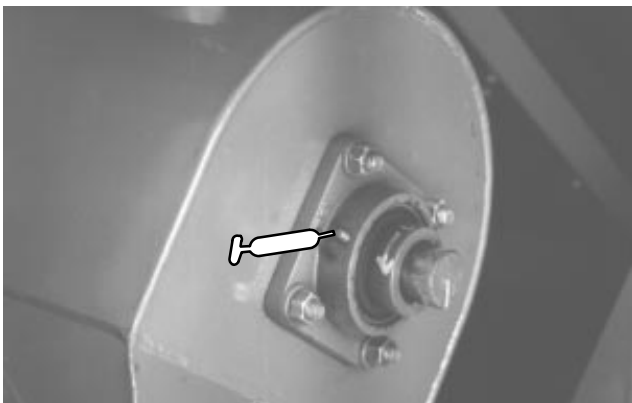

Figure 19

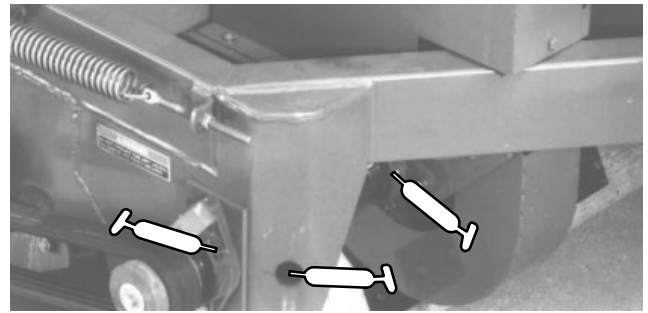

Figure 20

To lubricate drive shafts:

1. Disconnect sweeper from P.T.O. shaft on prime mover.
2. Rotate shafts by hand until you can see the grease fittings through the three holes in sides of shields.

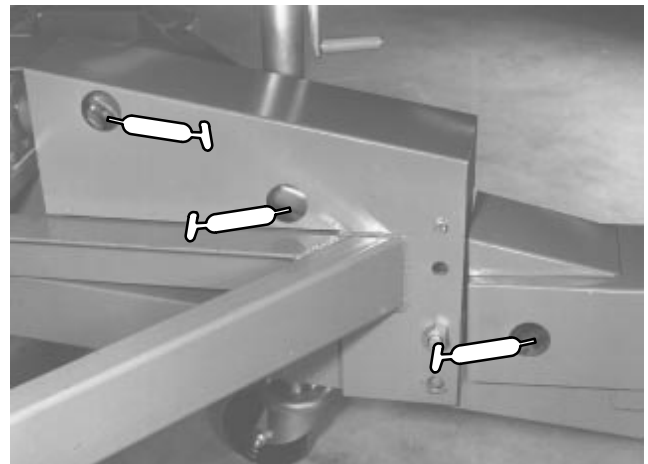

Figure 21

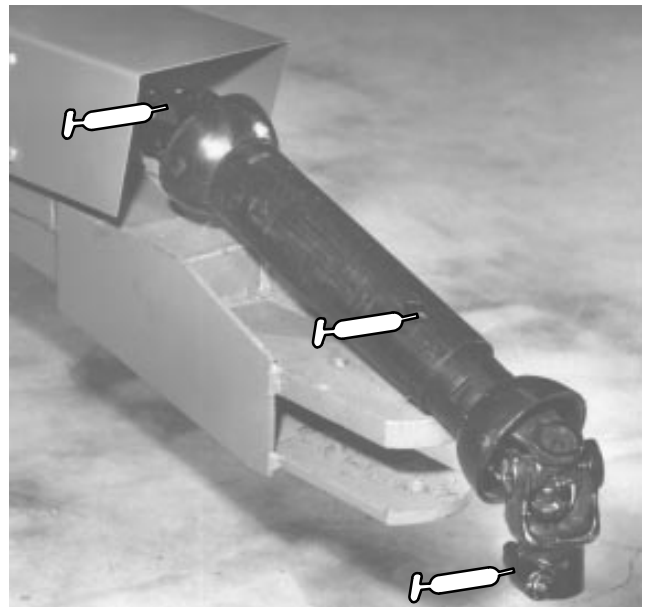

Figure 22

LUBRICATION

OIL DRIVE CHAIN (Model 07052)

Oil entire length of all chains every 30 hours of operation with SAE 30 oil.



Figure 23

OIL SWEEPER JACK

Sweeper jack must be oiled after every 50 hours of operation.



Figure 24

MAINTENANCE



CAUTION

Before servicing or making adjustments to the machine, disengage clutch, stop engine(s) and wait for all moving parts to stop.

CHANGING ENGINE OIL AND FILTER (Model 07050 only) (Fig. 25)

Change oil initially after the first 5 hours of operation, thereafter change oil every 100 hours and filter every 200 hours.

1. Park the machine on a level surface and turn the engine off.

2. Remove drain plug and let oil flow into drain pan. When oil stops, install drain plug.

NOTE: Warm oil flows better and carries more contaminants than cold oil.

3. Remove oil filter. Apply a light coat of clean oil to the new filter gasket.

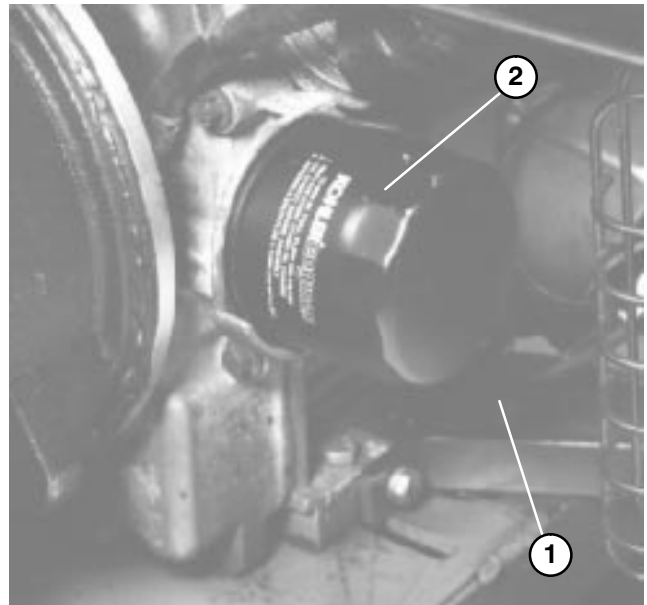

Figure 25

1. Drain plug
2. Oil filter

4. Screw filter on by hand until gasket contacts mounting plate, then tighten 1/2 turn further. DO NOT OVER-TIGHTEN.

5. Add oil to crankcase, refer to CHECK ENGINE OIL.

6. Dispose of used oil properly.

MAINTENANCE

SERVICING AIR CLEANER

(Model 07050 only)

Engine Plenum Chamber & Air Cleaner (Fig. 26 & 27)

The foam pre-cleaner must be cleaned and re-oiled after every 25 hours engine operation.

1. Remove wing nut and cover.

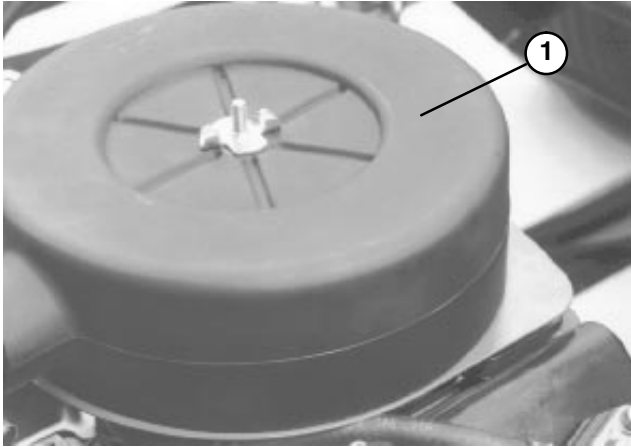

Figure 26

1. Air cleaner cover

2. Remove foam pre-cleaner by sliding it off the paper element.

A. Wash foam pre-cleaner in detergent and warm water.

B. Wrap foam pre-cleaner in cloth and squeeze dry. Do not wring pre-cleaner. Allow to air dry.

C. Saturate foam pre-cleaner in new engine oil. Squeeze to remove excess oil.

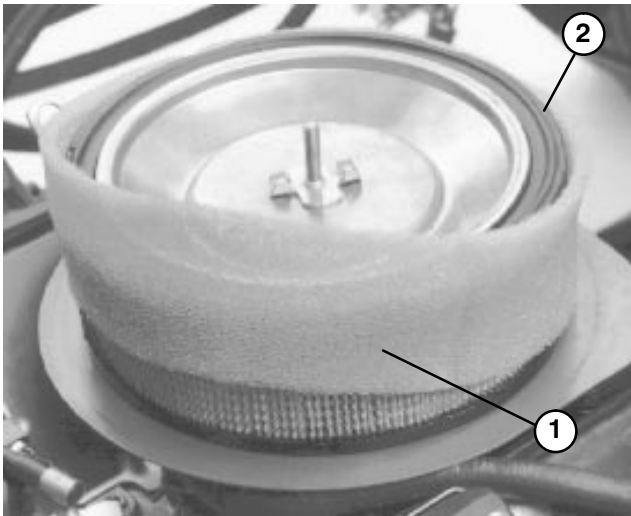

Figure 27

1. Pre-cleaner
2. Paper element

3. Inspect paper element every 100 hours of operation and replace if dirty or damaged. Change paper element when dirty. Do not wash paper element or do not clean with compressed air as damage will occur.

Note: With air cleaner disassembled, check air cleaner components for damage. Replace if necessary. Make sure rubber breather tube in base plate is securely in place or severe engine damage may occur.

4. Reinstall element with pre-cleaner, element cover sealing tube, air cleaner element cover, wing nut, second sealing tube, air cleaner cover and wing nut.

5. Tighten wing nut 1/2 to 1 turn after nut contacts cover. Do not overtighten.

PRIMARY AIR CLEANER

Bowl Assembly (Fig. 28)

Visually inspect the pre-cleaner bowl after every 8 hours operation or more frequently when operating conditions are extremely dusty and dirty. Never allow dust to build up above the level marks on outside of bowl.

A. Loosen thumb screw until cover and bowl can be removed. Separate cover and bowl.

B. Dump dust out of bowl and clean bowl. After cleaning, assemble and reinstall both parts.

Dust Cup And Baffle (Fig. 28)

Inspect the dust cup and rubber baffle after every 8 hours operation or more frequently when operating conditions are extremely dusty and dirty. Never allow dust to build up closer than one inch from the rubber baffle.

1. Loosen thumb screw until dust cup and baffle can be removed. Separate dust cup and baffle.

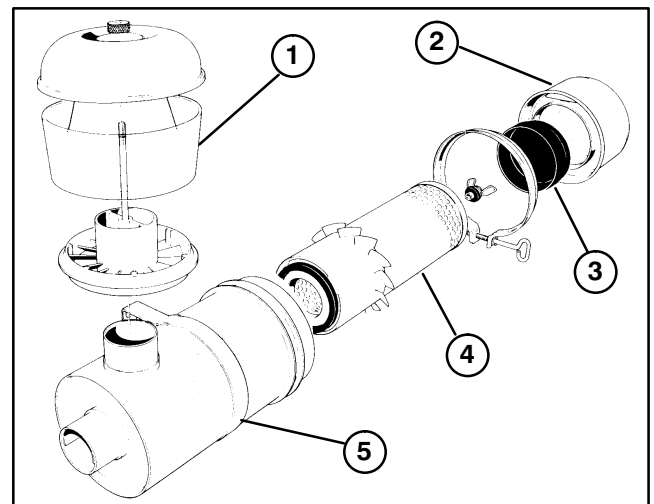

Figure 28

1. Bowl
2. Dust Cup
3. Baffle
4. Filter Element
5. Air Cleaner Body

2. Dump dust out of the dust cup. After cleaning cup and baffle, assemble and reinstall both parts.

MAINTENANCE

Filter Element (Fig. 28)

Service the air cleaner filter every 100 hours or more frequently in extreme dusty or dirty conditions by washing or using compressed air. Replace the element after every (5) cleanings (500 hours) or annually, whichever comes first.

1. Remove and service dust cup; refer to Servicing Dust Cup and Baffle.
2. Remove wing nut w/gasket and slide filter element out of air cleaner body.
3. Clean the element by washing it in a solution of filter cleaner (Toro Part No. 27-7220) and water, or blow dirt out of filter by using compressed air.

Note: Compressed air is recommended when element must be used immediately after servicing because a washed element must be dried before it is used. By comparison, washing the element cleans better than blowing dirt out with compressed air. Remember, though, filter must be washed when exhaust soot is lodged in the filter pores.

Washing Method

IMPORTANT: Do not remove plastic fin assembly because washing removes dust from beneath fins.

- A. Prepare a solution of filter cleaner and water and soak filter element about 15 minutes. Refer to directions on filter cleaner carton for complete information.
- B. After soaking filter for 15 minutes, rinse it with clear water. Maximum water pressure must not exceed 40 psi to prevent damage to the filter element.
- C. Dry filter element using warm, flowing air (160°F max), or allow element to air-dry. Do not use compressed air or a light bulb to dry the filter element because damage could result.

Compressed Air Method

IMPORTANT: Do not remove plastic fin assembly because back-blowing with compressed air removes dust from beneath fins.

- A. Blow compressed air from inside to the outside of dry filter element. Do not exceed 100 psi to prevent damage to the element.
- B. Keep air hose nozzle at least one inch from pleated paper, and move nozzle up and down while rotating the filter element. Inspect element when dust and dirt are removed; refer to Inspecting Filter Element.

4. Wipe inside of air cleaner body with a damp cloth to remove excess dust. Slide filter into air cleaner body and secure it in place with wing nut and gasket.

5. Reinstall dust cup and baffle. Move thumb screw behind air cleaner body and tighten it securely.

Inspecting Filter Element

1. Place bright light inside filter.
2. Rotate filter slowly while checking for cleanliness, ruptures, holes, and tears. Replace defective filter element.
3. Check fin assembly, gasket, and screen for damage. Replace filter if damage is evident.

REPLACING SPARK PLUGS

(Model 07050 only) (Fig. 29)

Replace spark plugs or reset gap after every 200 operating hours to assure proper engine performance and reduce exhaust emission level.

Correct spark plug to use is a Champion RC 12YC or equivalent.

Recommended air gap is .040".

Note: The spark plug usually lasts a long time; however, the plug should be removed and checked whenever the engine malfunctions.

1. Clean area around spark plugs so foreign matter cannot fall into cylinder when spark plug is removed.
2. Pull spark plug wires off spark plugs and remove plugs from cylinder head.
3. Check condition of side electrode, center electrode, and center electrode insulator to assure there is no damage.

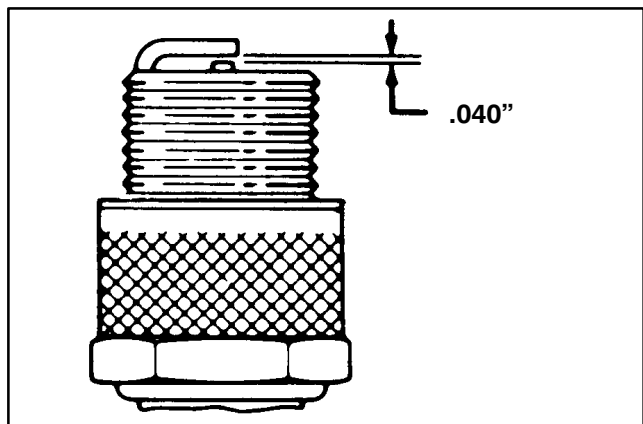

Figure 29

IMPORTANT: A cracked, fouled, dirty or otherwise malfunctioning spark plug must be replaced. Do not sand blast, scrape, or clean electrodes by using a wire brush because grit may eventually release from the plug and fall into the cylinder. The result is usually a damaged engine.

MAINTENANCE

REMOVING DEBRIS FROM ENGINE

(Model 07050 only)

To ensure proper cooling, make sure the grass screen, cooling fins and other external surfaces of the engine are kept clean at all times.

Every 100 hours of operation (more often under extremely dusty, dirty conditions) remove the blower housing and other cooling shrouds and clean the cooling fins and external surfaces as necessary. Make sure cooling shrouds are reinstalled.

NOTE: Operating the engine with a blocked grass screen, dirty or plugged cooling fins or cooling shrouds removed, will cause engine damage due to overheating.

REPLACE FUEL FILTER

(Model 07050 only) (Fig. 30)

Replace fuel filter after every 600 hours of operation.

1. Place a clean container under fuel filter.
2. Remove clamps securing fuel filter to fuel lines.

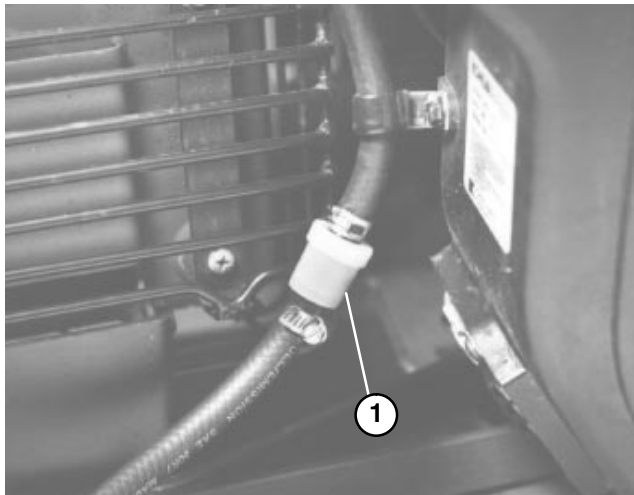

Figure 30
1. Fuel Filter

3. Install new fuel filter to fuel lines with clamps previously removed. Filter to be mounted so arrow points toward carburetor.

CHANGING CLUTCH HOUSING OIL

(Model 07050 only) (Fig. 31)

Clutch housing oil should be changed annually, or every 800 hours of operation, whichever comes first.

1. Place a drain pan under drain plug at bottom of housing.
2. Remove drain plug at bottom of housing and remove filler plug.

NOTE: Warm oil flows better and carries more contaminants than cold oil.

3. Allow all oil to drain out.
4. Replace drain plug.
5. Remove filler/breather plug from top of clutch housing.
6. Remove oil level plug on side of clutch housing.
7. Add enough oil to clutch housing until it drips out overflow hole.

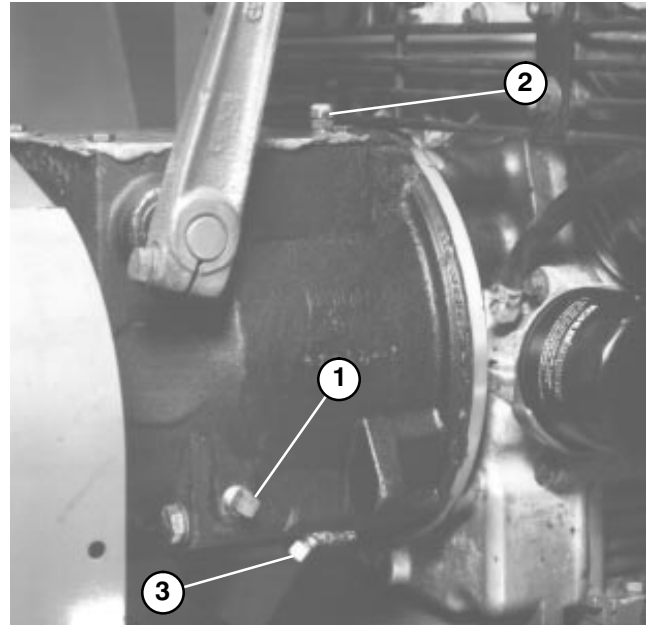

Figure 31
1. Overflow plug
2. Filler plug
3. Drain plug

8. Reinstall plugs.

ADJUSTING CLUTCH

(Model 07050 only) (Fig. 32)

A properly adjusted clutch will require 60–72 pounds of force applied to clutch handle, 8 inches above clutch lever pivot shaft. To adjust clutch proceed as follows:

1. Remove clutch cover plate.
2. Turn adjusting ring clockwise until proper adjustment is attained.
3. Install cover plate.



WARNING

Do not operate P.T.O. with clutch cover plate removed as rotating parts can cause injury.

MAINTENANCE

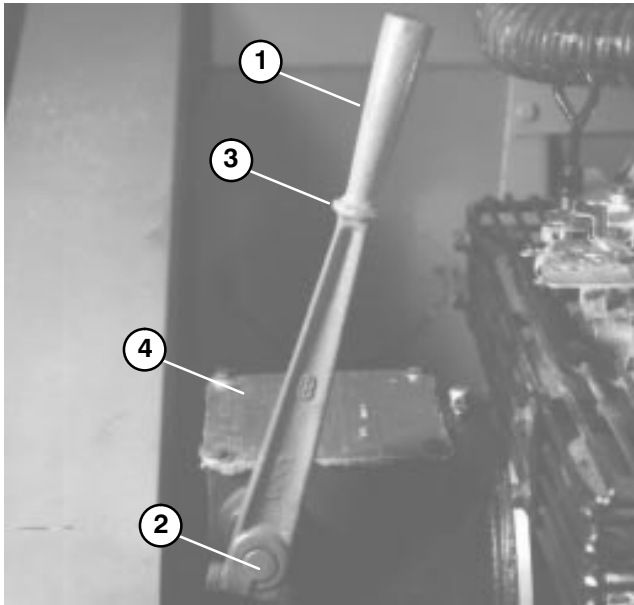

Figure 32

1. Clutch lever
2. Clutch lever pivot shaft
3. Apply force here
4. Cover plate

CHANGING RUBBER FLAP (Fig. 33)

Replace rubber flap when it becomes worn or damaged.

CAUTION

Change rubber flap on a flat, level surface and block wheels to prevent sweeper from rolling. Failure to do so may result in personal injury.

1. Remove (10) capscrews, washers, and nuts mounting flap and flap retainer.

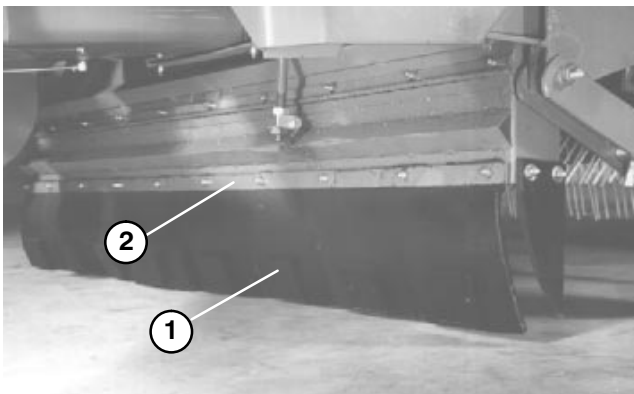

Figure 33

1. Rubber flap
2. Flap retainer

2. Replace with new rubber flap and fasten securely.

CLEANING BLOWER HOUSING (Fig. 34)



WARNING

Before removing any debris from blower housing, disengage clutch, disengage P.T.O. drive, stop engine(s) and make certain all moving parts have stopped or personal injury may occur.

1. Make sure impeller has stopped rotating before removing access plates.
2. Loosen (2) wing nuts securing access plate.

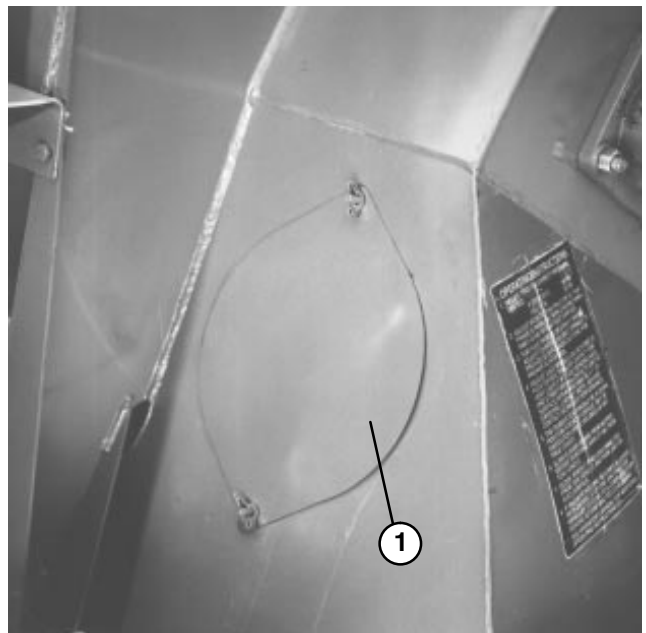

Figure 34

1. Access plate (2)

3. Swing access plate to one side allowing removal of debris.

4. After debris has been removed, lower access plate and secure with wing nuts. Repeat procedure on other access plate.

ADJUSTING BELTS

Check condition and tension of belts after first day of operation and every 200 operating hours thereafter.

Impeller Drive Belt (Model 07050 only) (Fig. 35–38)

1. Check tension by depressing belt at mid span of impeller and clutch pulleys with 3.8–5.2 lbs. of force. Belt should deflect .53 in. If deflection is incorrect, proceed to next step. If correct, continue operation.

MAINTENANCE

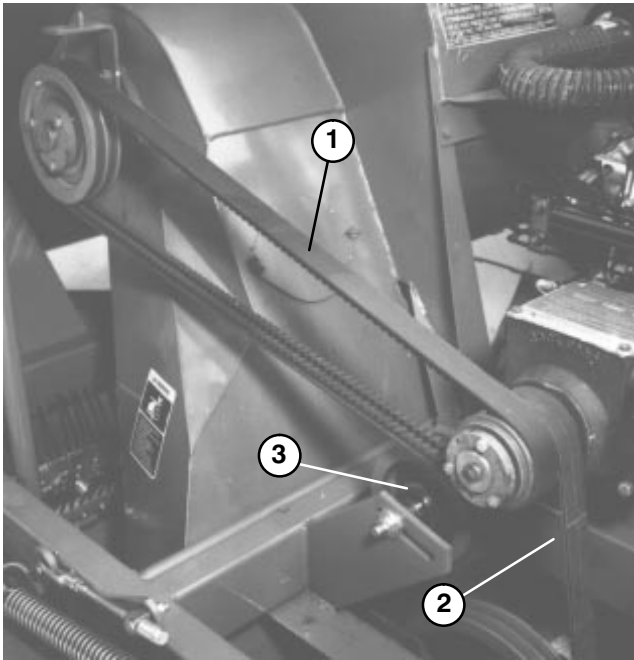

Figure 35

1. Impeller belt
2. Jackshaft belt
3. Idler pulley

NOTE: It is not necessary to remove upper belt guard (Fig. 36) to check belt tension. If for some reason belt guard must be removed, remove (4) capscrews, washers and nuts securing guard to frame. **Never operate sweeper without guards in place.**

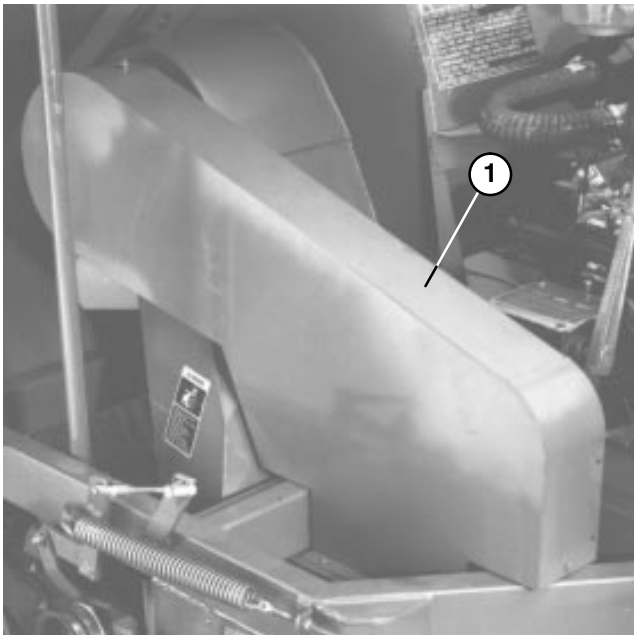

Figure 36

1. Upper belt guard

2. To adjust belt tension:

A. Loosen (4) engine mounting bolts.

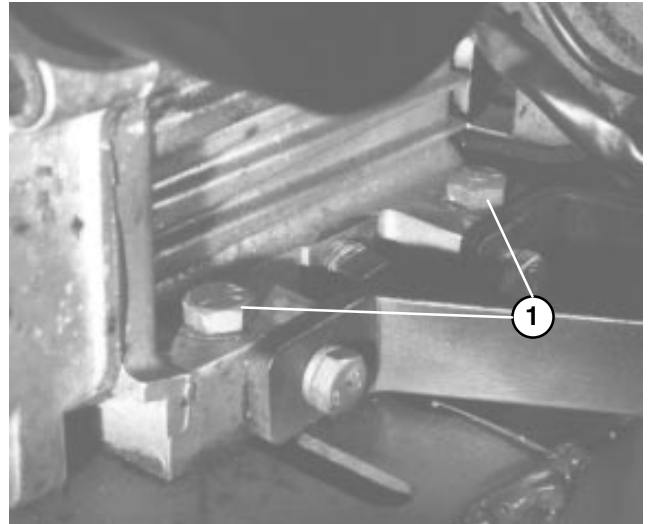

Figure 37

1. Engine mounting bolts

B. Turn belt adjusting (Fig. 38) bolt until desired belt tension is obtained. Retighten engine mounting bolts. Reorient engine to make sure engine is parallel with frame. Retighten engine mounting bolts.

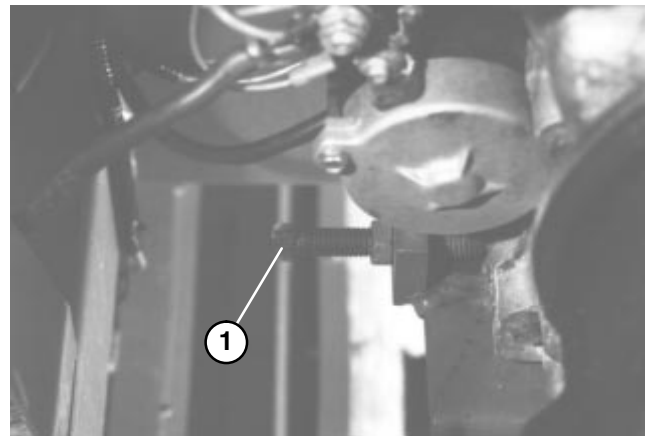

Figure 38

1. Adjusting bolt

3. Whenever impeller belt is adjusted it is necessary to readjust jackshaft belt (engine drive) or chain (PTO drive).

Impeller Drive Belt (Model 07052 only) (Fig. 39)

1. Check tension by depressing belt at mid span of impeller and reel gear case pulleys with 5–7 lbs. of force. Belt should deflect .49 in. If deflection is incorrect, proceed to next step. If correct, continue operation.

2. To adjust belt tension:

A. Loosen drive chain idler sprocket and back it off completely (Fig. 42).

B. Loosen (4) capscrews on gear box base and (2) capscrews on gear box shields.

MAINTENANCE

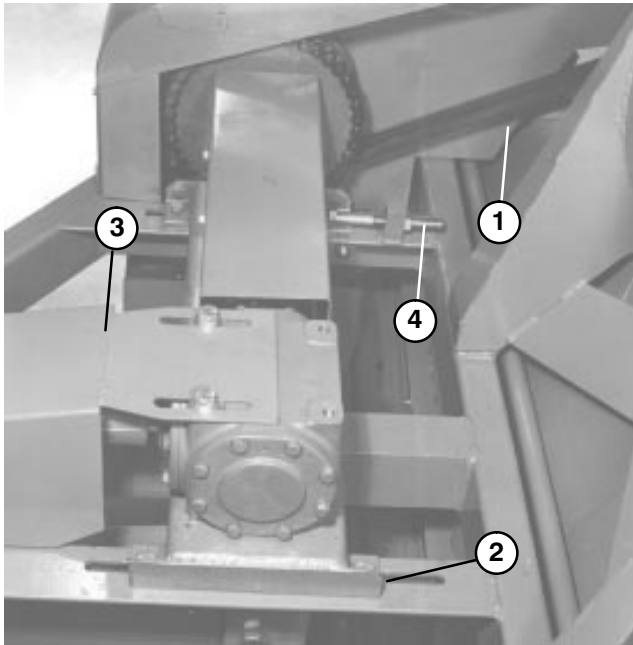

Figure 39

1. Drive belt
2. Gear box base
3. Gear box shield
4. Adjustment bolt

C. Turn adjustment bolt on back on gear box base until proper belt tension is attained.

D. Square up gear box base parallel to frame by moving L.H. end (gear box end) to required position.

E. Tighten all capscrews.

NOTE: Make sure gear box base is square on frame and not set on an angle when adjusting belt tension.

F. Readjust and tighten idler sprocket on drive chain.

Jackshaft Belt (Model 07050 only) (Fig. 35)

1. Check tension by depressing belt at mid span of jackshaft and clutch pulleys with 3.8–5.2 lbs. of force. Belt should deflect .23 in. If deflection is incorrect, proceed to next step. If correct, continue operation.

2. To adjust belt tension:

A. Remove (4) capscrews, washers and nuts securing upper shroud to frame (Fig. 36).

B. If belt has too much slack, loosen idler pulley nut, press forward on idler pulley until desired tension is obtained and retighten idler pulley nut.

C. If belt is too tight, loosen idler pulley nut, pull rearward on idler pulley until desired tension is obtained and retighten idler pulley nut.

Reel Drive Belt (Fig. 40–41)

1. Check tension by depressing belt at mid span of idler pulley and reel driver pulley with 25–29 lbs. of force. Belt should deflect .26 in. If deflection is incorrect, proceed to next step. If correct, continue operation.

2. To adjust belt tension:

A. Remove (2) capscrews, nut, retaining nut and washer securing lower belt guard to frame (Fig. 40). Remove guard.

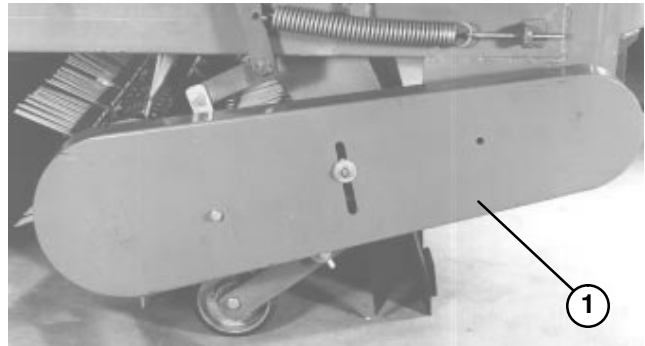

Figure 40

1. Lower belt guard

B. If belt has too much slack, loosen idler pulley nut (Fig. 41), press down on idler pulley until desired tension is obtained and retighten idler pulley nut.

C. If belt is too tight, loosen idler pulley nut (Fig. 41), pull upward on idler pulley until desired tension is obtained and retighten idler pulley nut.

D. Reinstall guard. Make sure there is clearance between belt and belt guard.

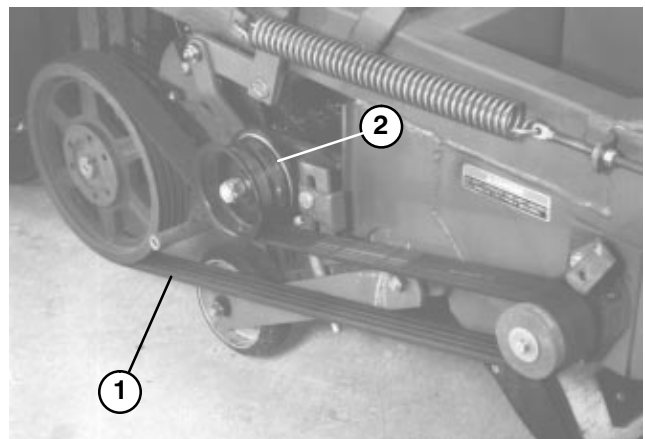

Figure 41

1. Reel drive belt
2. Idler pulley

ADJUSTING CHAIN

Drive Chain (Model 07052 only) (Fig. 42)

1. Check tension by pressing side of chain at mid span of upper and lower drive sprockets with 10 lbs. of force. Chain should deflect .10 in. in each direction from center (.20 total deflection from side to side). If deflection is incorrect, proceed to next step. If correct, continue operation.

MAINTENANCE

2. To adjust drive chain tension:

A. Remove idler sprocket mounting capscrew.

B. Add or delete spacers behind idler sprocket until upper drive sprocket and lower drive sprocket properly aligned.

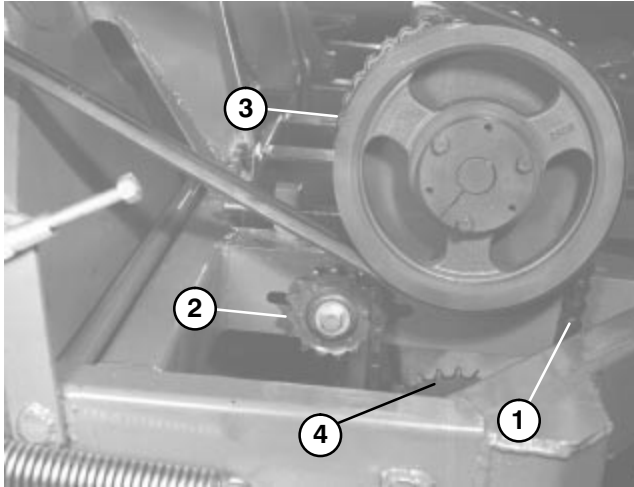

Figure 42

1. Drive chain
2. Idler sprocket
3. Upper drive sprocket
4. Lower driven sprocket

C. To increase chain tension push idler sprocket toward chain. To decrease chain tension push idler sprocket away from chain.

NOTE: Make sure all sprockets are in alignment. Failure to do this could result in throwing of chains, plugging sweeper and may result in personal injury.

CHANGING GEAR BOX OIL

(Model 07052 only) (Fig. 43)

Change gear box oil every 800 hours of operation .

1. Remove capscrews securing shield to gear box and frame.



WARNING

DO NOT OPERATE SWEEPER WITH SAFETY SHIELDS REMOVED. If safety shields are removed from sweeper and maintenance is being performed, make sure universal coupler is disconnected from prime mover P.T.O. shaft.

2. Place a pan on the ground beneath gear box.

3. Remove oil drain plug from bottom of gear box and allow all oil to drain out.

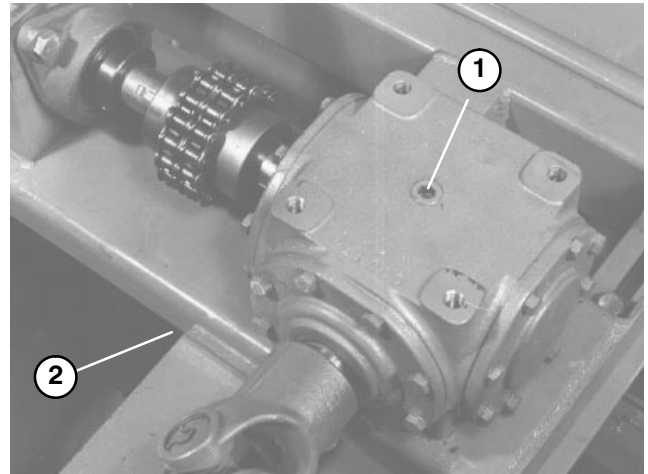

Figure 43

1. Fill plug/breather
2. Drain plug

4. When all oil has drained out of gear box secure oil drain

5. Remove oil fill plug/breather from top of gear box.

6. Fill gear box with 1 – 1/2 pints of 80 or 90 weight oil.

7. Insert plug in hole and secure.

GEAR BOX REMOVAL (Model 07052 only)

(Fig. 44 & 45)

1. Remove capscrews securing shield to gear box and frame.

2. Remove (4) capscrews securing bottom of gear box to gear box base plate.

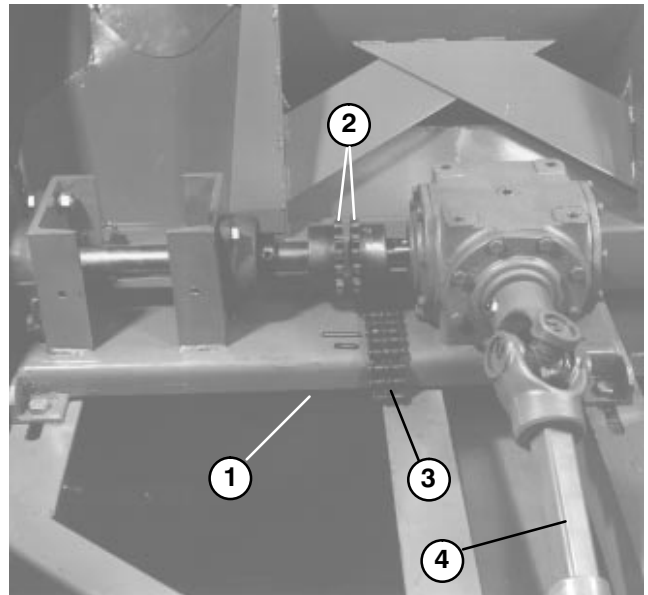

Figure 44

1. Gear box base plate
2. Coupler sprockets
3. Double coupler chain
4. Universal shaft

3. Disconnect double coupler chain by removing clip and pin and remove from coupler sprockets.

MAINTENANCE

4. Pull gear box to the rear of sweeper until universal shaft pulls out of its housing.

5. Lift gear box from sweeper and perform maintenance. To mount gear box back on sweeper reverse procedure.

NOTE: When gear box is set back on gear box base make sure it is squared up as close as possible.



WARNING

If the side coupler sprocket and the front universal joint are removed from gear box make sure they are replaced in the same orientation on the gear box. (Note there is an end plate cover on the opposite side of the coupler sprocket, but there is no end plate cover on opposite side of universal joint) Failure to do this will cause extreme high speed operation of the sweeper and may cause personal injury.

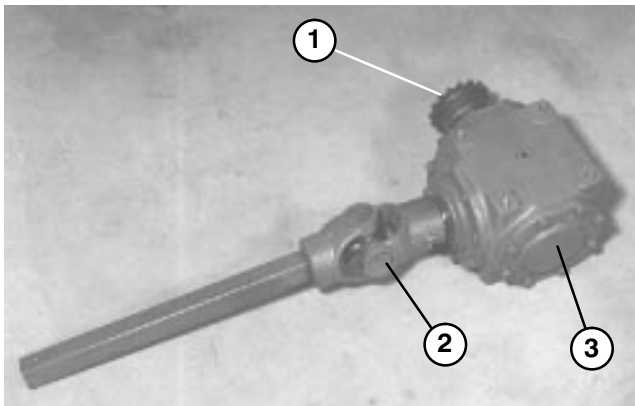

Figure 45

1. Side coupler sprocket
2. Front universal joint
3. End plate cover

LOCKING COLLAR REMOVAL (Model 07052 only) (Fig. 46)

If it becomes necessary to replace the bearings or shaft, the eccentric locking collars must be removed, proceed as follows:

1. Remove shields over drive shafts.
2. To loosen eccentric locking collar, place a punch in cutout on collar. Using a hammer, drive collar in opposite direction of the shafts rotation.

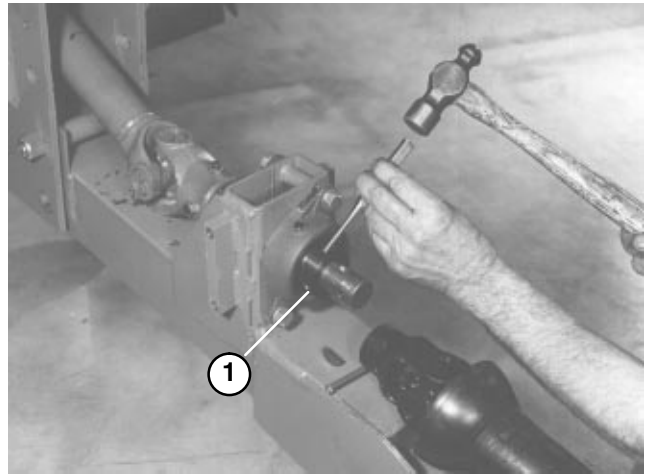

Figure 46

1. Eccentric locking collar

3. Slide collar off shaft and replace necessary parts.
4. Slide collar back onto shaft and snug it up tight against bearing.
5. With the hammer and punch, drive eccentric locking collar in the direction of the shafts rotation. This will tighten collar.
6. Install all shields.

PULLEY REMOVAL (Fig. 47)

To remove any pulley secured by a taper lock bushing, proceed as follows:

1. Remove capscrews and lockwashers one at a time and screw into adjoining holes.

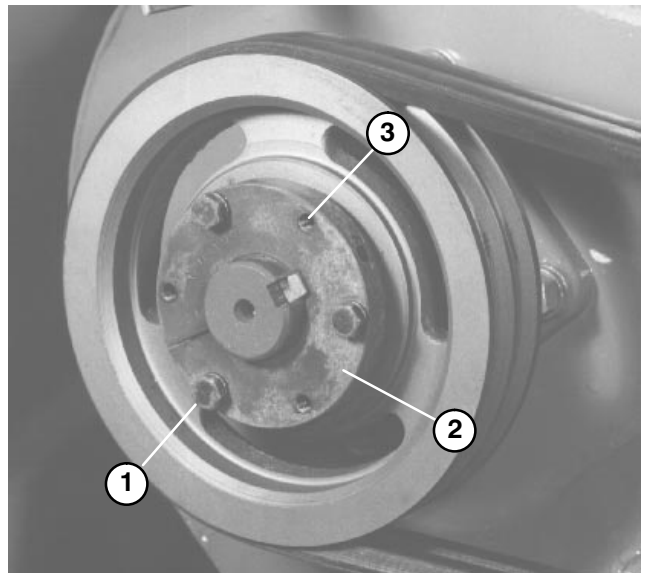

Figure 47

1. Capscrews & lockwasher
2. Taper lock bushing
3. Taper lock release hole

2. Turn each capscrew the same number of times until lock separates. Pulley will now slide off shaft.

MAINTENANCE

FLEX TIP REEL REMOVAL

Removal of flex tip reel should be done on a hard and level surface.

1. Raise front of sweeper as high as possible by lowering jack.
2. Raise reel to highest position.
3. Remove lower belt guard (Fig. 40) and reel drive belt (Fig. 41).
4. Remove (2) capscrews, lockwashers and nuts securing reel shaft bearings to reel support arms on each side of sweeper. Lower flex tip reel to the ground.
5. Lift reel support arms to the highest position.
6. Slide end of rake rearward and pull out from under machine.

THATCHER INSTALLATION(Fig. 48 & 49)

A 32 tooth jackshaft sprocket, a 19 tooth idler sprocket and a No. 60 chain make up the Thatcher Kit Drive Components.

1. Remove lower belt guard (Fig. 40) and reel drive belt (Fig. 41).
2. Remove capscrew and washer securing jackshaft pulley to jackshaft and remove pulley.

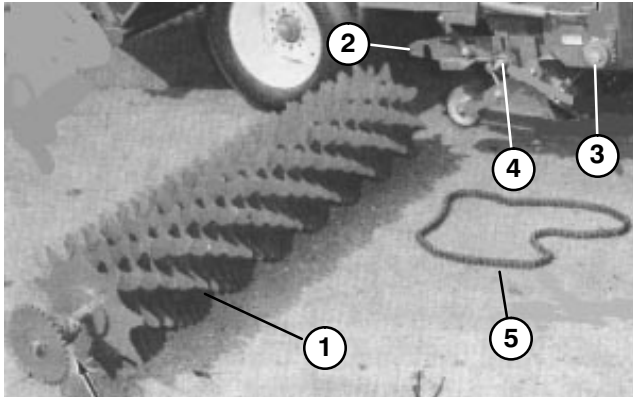

Figure 48

1. Thatcher reel
2. Reel support arm
3. Jackshaft sprocket
4. Idler sprocket
5. Chain

3. Slide 16 Tooth Jackshaft sprocket onto jackshaft.
4. Secure by tightening two (2) set screws and lock nuts on sprocket hub.
5. Remove idler pulley presently on machine and replace it with 19 tooth (#60) idler sprocket supplied with Thatcher Kit.
6. Slide Thatcher into position and secure to reel support arms.
7. Align idler sprocket with jackshaft sprocket and thatcher sprocket.

8. Install No. 60 chain, included in kit. Lubricate with SAE 30 oil.
9. Push down on idler sprocket until desired chain tension is obtained.

10. Fasten idler sprocket securely.

NOTE: Spacers mounted on lift mechanism adjusting screws must be removed when thatcher is installed on machine.

11. Put reel support arms in a lowered position.

12. Remove jam nut and adjusting screw. Slide spacer off adjusting screw.

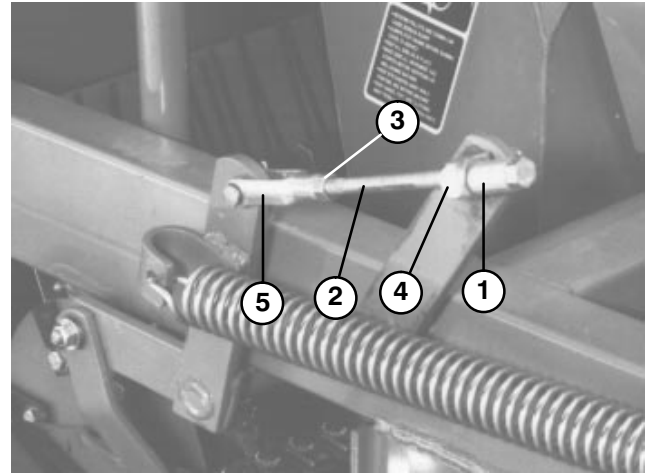

Figure 49

1. Spacer
2. Adjusting screw
3. Jam nut
4. Pivot block
5. Clevis

13. Reassemble jam nut and adjusting screw with spacer positioned on adjusting screw between pivot block and clevis. This is the storage position for spacer during thatcher operation.

14. Repeat procedure on other side of sweeper.

NOTE: Spacers should be re-installed whenever the thatcher is removed and either the brush or flex tip reel is mounted to sweeper.

FLEX TIP RAKE ROD OR FINGER PLATE REPLACEMENT (Fig. 50 & 51)

1. Remove capscrew and locknut from one end of reel.
2. Remove locknut only, from opposite end of reel.
3. Drive rod from end plate. Drive rod from end without the tab welded to it.
4. Remove finger plates or rods as required and replace.
5. Line up finger plate with rod and drive rod back through end plate.

MAINTENANCE

6. Attach capscrew and locknuts and hook up springs.

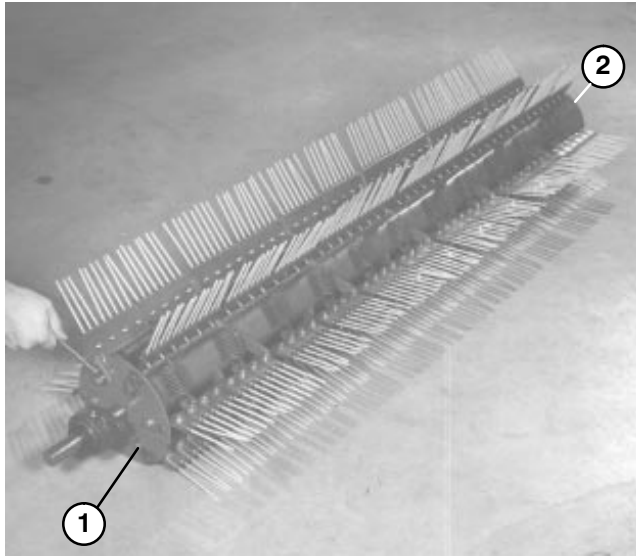

Figure 50
 1. Capscrew and locknut
 2. Locknut

FLEX TIP RAKE TINE REPLACEMENT (Fig. 51)

1. Remove tine retainer and slide damaged tine out.

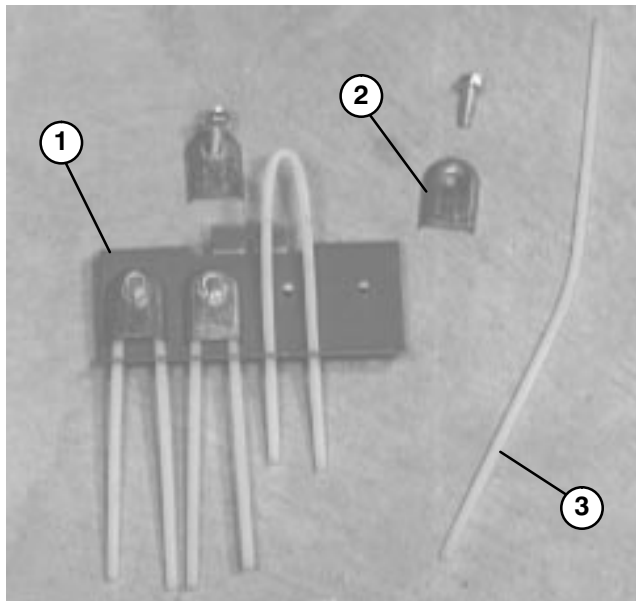

Figure 51
 1. Finger plate
 2. Tine retainer
 3. Tine

2. Bend new tine in half and slide into position.
 3. Place tine bracket over curved end of tine and fasten securely with capscrew and lockwasher.
- 26

BRUSH HALF REPLACEMENT (Fig. 52 & 53)

1. Remove brush from sweeper.
2. Loosen clamps with a allen wrench and remove from brush halves.

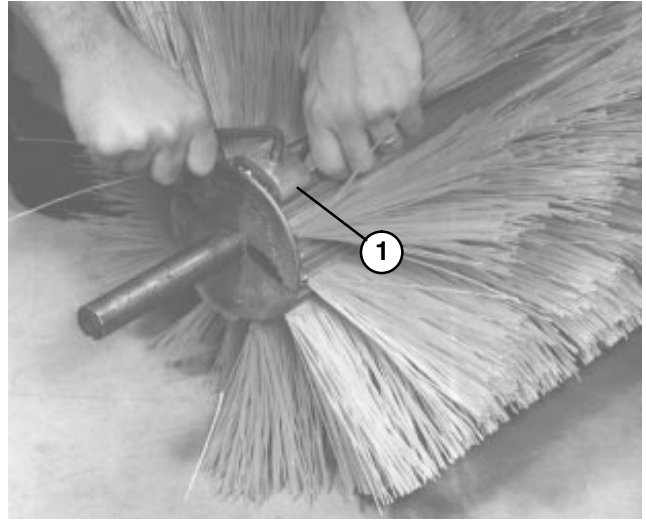

Figure 52
 1. Clamp

3. Separate brush halves and discard damaged section(s).

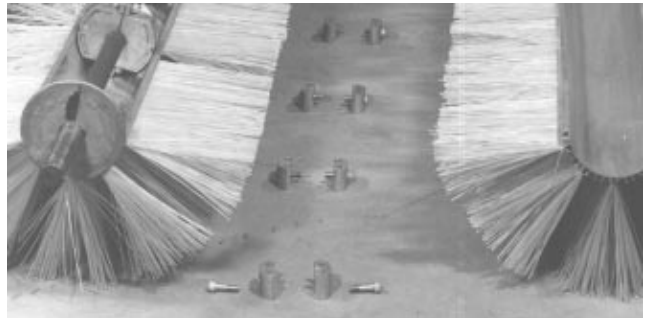



Figure 53

4. Install new brush section(s) by pushing together and secure both ends with brush clamps. When ends have been secured, fasten brush with remaining clamps.

CHANGING TIRES

1. Park machine on a flat, level surface. Block other tire to prevent accidental rolling or injury.
2. Place jack under frame or axle shaft behind wheel and jack up wheel until it just contacts floor.

 **WARNING**

A 2000 lb. capacity hydraulic jack should be used when changing a tire.

3. Loosen all lug bolts and continue to jack up until tire can be removed.
4. Reverse above procedure to install tire. Torque lug bolts to 70 to 90 ft. / lbs.

MAINTENANCE

BATTERY CARE (Model 07050 only)

1. Battery electrolyte level must be properly maintained and the top of the battery kept clean. If the machine is stored in a location where temperatures are extremely high, the battery will run down more rapidly than if the machine is stored in a location where temperatures are cool.
2. Keep top of battery clean by washing periodically with a brush dipped in ammonia or bicarbonate of soda solution. Flush the top surface with water after cleaning. Do not remove the fill cap while cleaning.
3. Battery cables must be tight on terminals to provide good electrical contact.
4. If corrosion occurs at terminals, disconnect cables, negative (-) cable first and scrape clamps and terminals separately. Reconnect cables, positive (+) cable first and coat terminals with petroleum jelly.
5. Check the electrolyte level every 25 operating hours or, if machine is in storage, every 30 days.



CAUTION

Wear safety goggles and rubber gloves when working with electrolyte. Charge the battery in a well ventilated place so gasses produced while charging can dissipate. Since the gases are explosive, keep open flames and electrical spark away from the battery; do not smoke. Nausea may result if the gases are inhaled. Unplug charger from electrical outlet before connecting to or disconnecting charger leads from battery posts.

6. Maintain cell level with distilled or demineralized water. Do not fill cells above fill line.
7. If machine will be stored for more than 30 days, remove the battery and charge it fully. Either store it on the shelf on the machine. Leave the cables disconnected if stored on the machine. Store the battery in a cool atmosphere to avoid quick deterioration of the charge in the battery. To prevent battery from freezing, make sure it is fully charged. The specific gravity of a fully charged battery is 1.250.

IDENTIFICATION AND ORDERING

MODEL AND SERIAL NUMBERS

The RAKE-O-VAC has two identification numbers: a model number and a serial number. These numbers are stamped into a plate located on the main frame. In any correspondence concerning the unit, supply the model and serial numbers to ensure correct information and replacement parts are obtained.

Note: Do not order by reference number if a parts catalog is being used; use the part number.

To order replacement parts from an authorized TORO Distributor, supply the following information:

1. Model and serial numbers.
2. Part number, description, and quantity of parts desired.

The Toro Promise

A One Year Limited Warranty

The Toro Company promises to repair your TORO product if defective in materials or workmanship. The following time periods from the date of purchase apply:

Commercial Products 1 Year

The cost of parts, labor and transportation are included.

If you feel your TORO Product is defective and wish to rely on The Toro Promise, the following procedure is recommended:

1. Contact your Authorized TORO Distributor or Commercial Dealer (the Yellow Pages of your telephone directory is a good reference source).
2. The TORO Distributor or Commercial Dealer will advise you on the arrangements that can be made to inspect and repair your product.
3. The TORO Distributor or Commercial Dealer will inspect the product and advise you whether the product is defective and, if so, make all repairs necessary to correct the defect without an extra charge to you.

If for any reason you are dissatisfied with the distributor's analysis of the defect or the service performed, you may contact us.

Write:

TORO Commercial Products Service Department
8111 Lyndale Avenue South
Minneapolis, MN 55420

The above remedy of product defects through repair by an Authorized TORO Distributor or Commercial Dealer is the purchaser's sole remedy for any defect.

THERE IS NO OTHER EXPRESS WARRANTY. ALL IMPLIED WARRANTIES OF MERCHANTABILITY AND FITNESS FOR USE ARE LIMITED TO THE DURATION OF THE EXPRESS WARRANTY.

Some states do not allow limitations on how long an implied warranty lasts, so the above limitation may not apply to you.

This Warranty applies only to parts or components which are defective and does not cover repairs necessary due to normal wear, misuse, accidents, or lack of proper maintenance. Regular, routine maintenance of the unit to keep it in proper operating condition is the responsibility of the owner.

All warranty repairs reimbursable under The Toro Promise must be performed by an Authorized Toro Commercial Dealer or Distributor using Toro approved replacement parts.

Repairs or attempted repairs by anyone other than an Authorized TORO Distributor or Commercial Dealer are not reimbursable under the TORO Promise. In addition, these unauthorized repair attempts may result in additional malfunctions, the correction of which is not covered by warranty.

THE TORO COMPANY IS NOT LIABLE FOR INDIRECT, INCIDENTAL OR CONSEQUENTIAL DAMAGES IN CONNECTION WITH THE USE OF THE PRODUCT INCLUDING ANY COST OR EXPENSE OF PROVIDING SUBSTITUTE EQUIPMENT OR SERVICE DURING PERIODS OF MALFUNCTION OR NON-USE.

Some states do not allow the exclusion of incidental or consequential damages, so the above exclusion may not apply to you.

This warranty gives you specific legal rights, and you may also have other rights which vary from state to state.

COUNTRIES OTHER THAN THE UNITED STATES OR CANADA

Customers who have purchased TORO products exported from the United States or Canada should contact their TORO Distributor (Dealer) to obtain guarantee policies for your country, province, or state. If for any reason you are dissatisfied with your Distributor's service or have difficulty obtaining guarantee information, contact the TORO importer. If all other remedies fail, you may contact us at The Toro Company.