

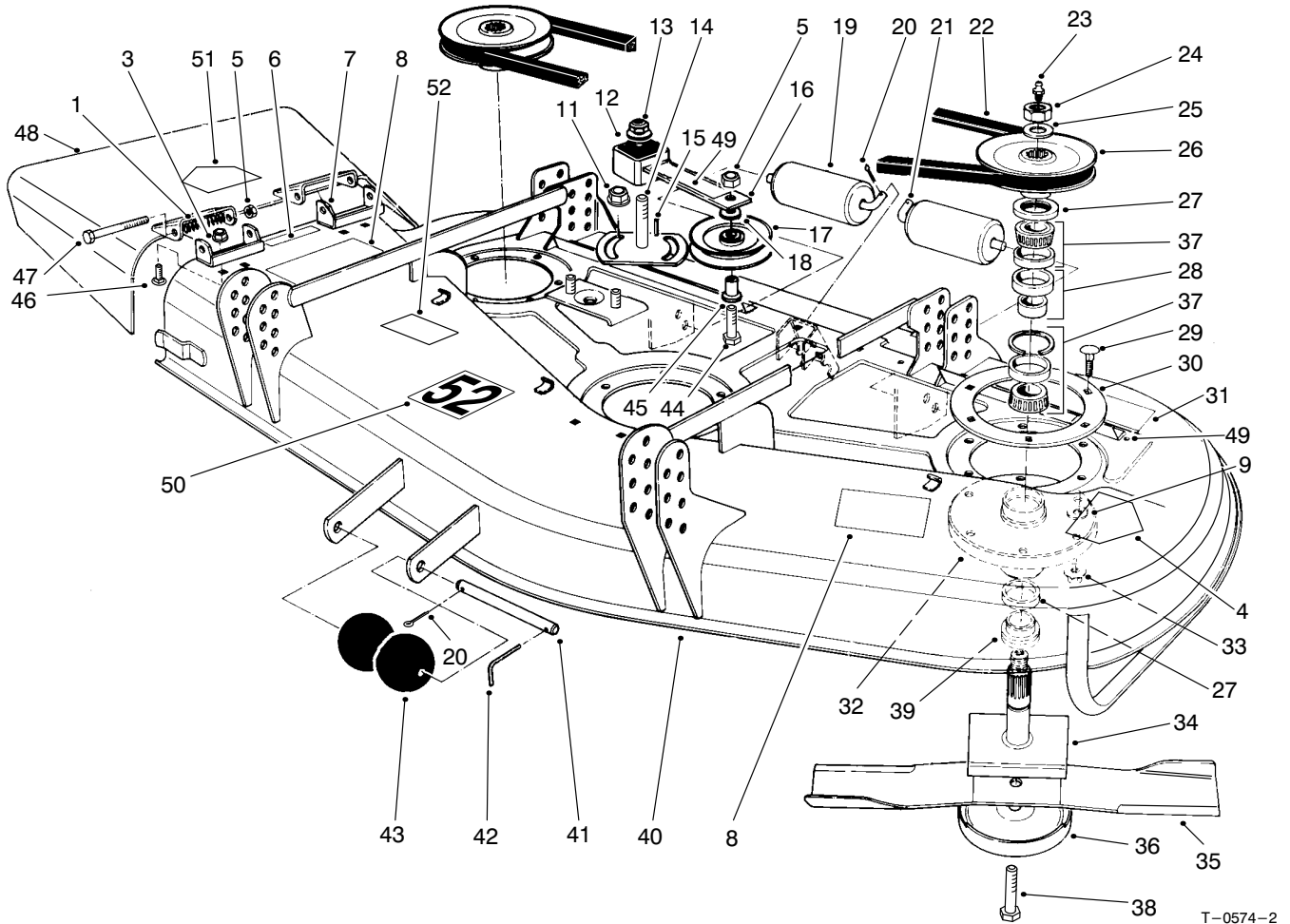

MODEL NO. 30555 - 70001 & UP
 MODEL NO. 30555TE-70001 & UP

**PARTS
 CATALOG**

52" SIDE-DISCHARGE CUTTING UNIT
 For Groundsmaster® 200 Series



DECK AND SPINDLE ASSEMBLY

Ref. No.	Part No.	Description	No. Used
1	40-6230	Spring - Torsion	1
3	32128-20	Nut - Lock	4
4	43-8480	Decal - Danger	1
4	93-7815	Decal - Danger (Europe)	1
5	3296-5	Nut - Lock	3
6	66-6380	Decal - Danger	1
6	93-7828	Decal - Danger (Europe)	1
7	29-5590	Pivot Bracket - Deflector	2
8	66-1340	Decal - Danger	2
8	93-7824	Decal - Danger (Europe)	2
9	3256-24	Washer - Flat	18
11	3290-357	Nut - Flange	2
12	3256-27	Washer - Flat	1
13	3296-33	Nut - Lock	1
14	28-9060	Plate - Idler	1
15	5-1077	Key - Square	1
16	27-8580	Idler Socket	1

Ref. No.	Part No.	Description	No. Used
17	65-5940	Pulley - Idler	1
18	7-0081	Washer - Special	1
19	36-1740	Roller - Deck	2
20	3272-11	Pin - Cotter	3
21	40-0340	Shaft - Rear Roller	2
22	27-1160	V-Belt	1
23	302-2	Fitting - Grease	3
24	32146-20	Nut - Lock	3
25	7-4150	Washer	3
26	27-0970	Pulley	3
27	253-139	Seal - Wave	6
28	27-5970	Spacer - Matched Set	1
29	3231-22	Bolt - Carriage	18
30	27-7680	Ring - Deck Support	3
31	68-8340	Decal - Torque	1
31	93-7818	Decal - Torque (Europe)	1
32	61-4160	Housing - Spindle	3

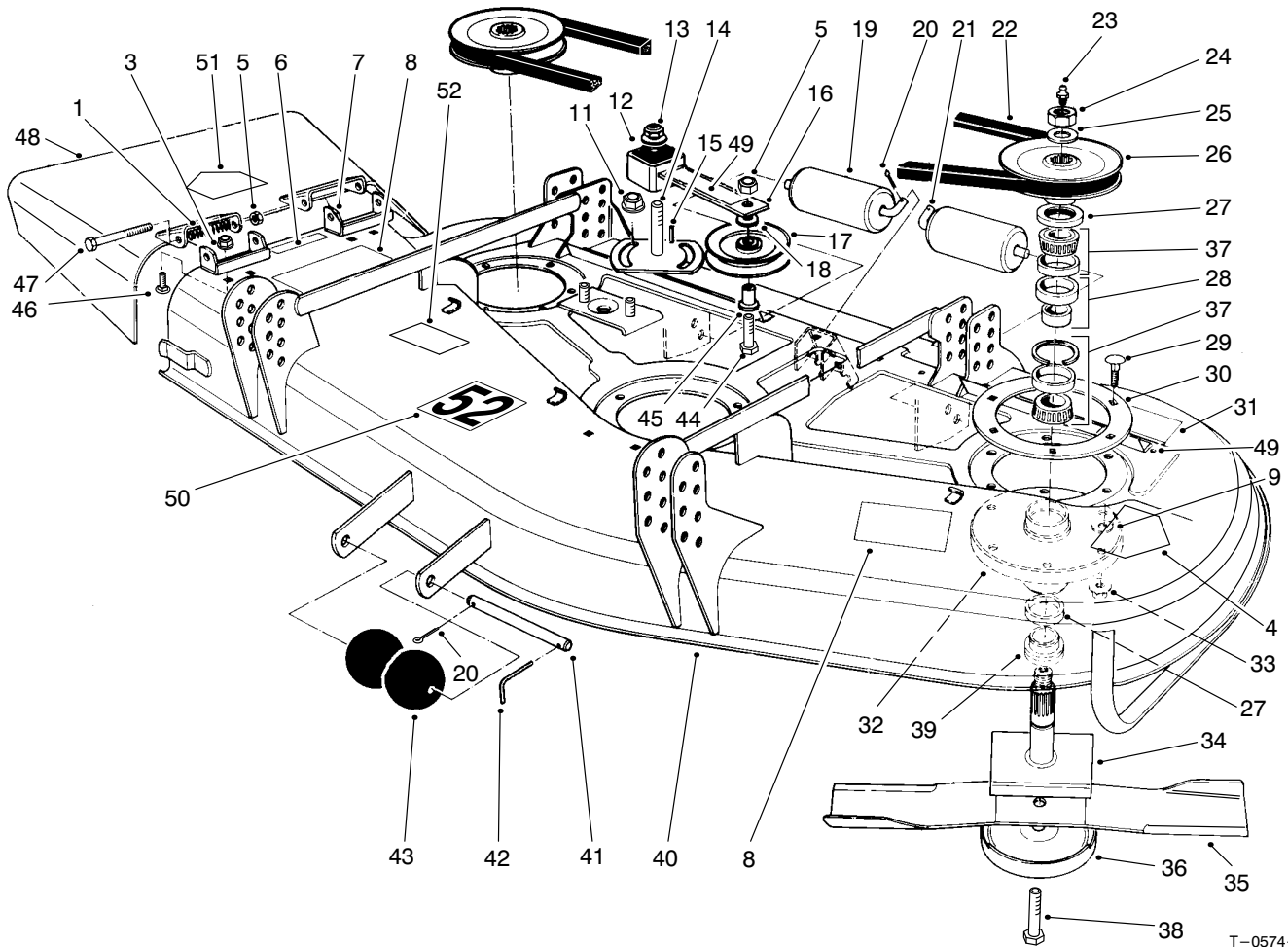

T-0574-2

DECK AND SPINDLE ASSEMBLY (Continued)

Ref. No.	Part No.	Description	No. Used
33	32128-21	Nut - Flange	18
34	27-0920	Spindle - Shaft	3
35	27-0990	Blade	3
*	44-5480	Blade - High Sail (Optional)	3
36	72-9361	Anti-Scalp Cup	3
37	27-0960	Bearing Set - Matched	3
38	92-5816	Screw - Blade Bolt	3
39	27-0950	Spacer - Spindle Bearing	3
40	92-8792	Deck Assembly (Incl. Ref. #4, 6, 8, 31, 49, 50 & 52)	1
40	95-6274	Deck Assembly (Europe) (Incl. Ref. #4, 6, 8, 31, 49, 50 & 52)	1
41	40-6400	Shaft - Roller	1
42	57-0690	Pin - Cotter	1
43	29-4820	Roller	2
44	3211-8	Screw - Cap Hex. Hd.	1
45	65-5950	Bushing - Pulley	1
46	3230-23	Bolt - Carriage	4

Ref. No.	Part No.	Description	No. Used
47	3211-15	Screw - Cap Hex. Hd.	2
48	93-8714	Grass Deflector Assembly (Incl. Ref. #51)	1
49	67-5360	Decal - Danger	2
49	93-7273	Decal - Danger (Europe)	2
50	92-8779	Decal - Warning	1
50	93-7808	Decal - Warning (Europe)	1
51	54-9220	Decal - Danger	1
51	93-7316	Decal - Danger (Europe)	1
52	51-3960	Decal - 52"	1
*	46-8530	Bearing Assembly (Incl. Ref. #28 & 37)	3
*	27-0870	Spindle Assembly (Incl. Ref. #23-28, 32, 34 & 39)	3
*	95-3078	Spindle Kit (Incl. Ref. #9, 23-29, 32-34 & 36-39)	3
*	95-3070	Blade & Belt Kit (Incl. Ref. 22 & 35)	1

*Not Illustrated

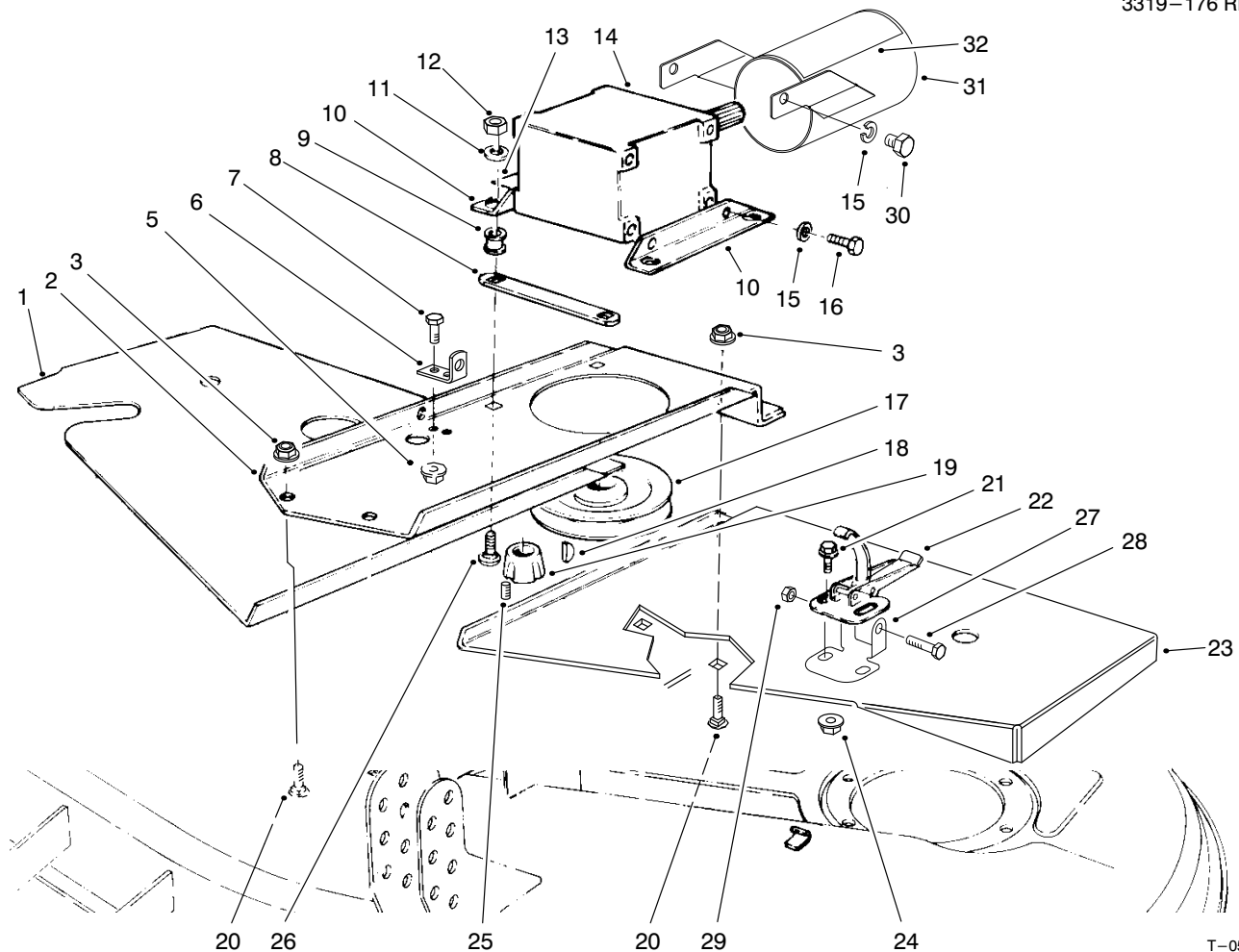

T-0576-2

COVERS AND GEAR BOX ASSEMBLY

Ref. No.	Part No.	Description	No. Used	Ref. No.	Part No.	Description	No. Used
1	72-9330	Cover R.H.	1	18	3257-5	Key - Woodruff	1
2	72-9230	Base - Gear Box	1	19	27-6140	Bushing - Taper Lock (Incl. Ref. #25)	1
3	3290-357	Nut - Flange	4	20	3231-27	Bolt - Carriage	4
5	32128-20	Nut - Flange	2	21	3290-321	Screw - Machine	6
6	72-9240	Bracket - Extension	1	22	249-21	Latch - Draw	3
7	322-4	Screw - Cap Hex. Hd.	2	23	72-9340	Cover L.H.	1
8	68-9890	Cover - Gear Box	1	24	32128-17	Nut - Flange	6
9	63-9750	ISO Mount - Gear Box	4	25	3245-9	Screw - Set	2
10	68-8560	Bracket - Gear Box	2	26	3231-26	Bolt - Carriage	4
11	63-8410	Washer	4	27	93-7043	Retainer (Europe)	2
12	32153-2	Nut	4	28	321-8	Screw - HH (Europe)	2
13	70-2560	Decal - Lube	1	29	3296-56	Nut - Hex. Lock (Europe)	2
13	93-6697	Decal - Lube (Europe)	1	30	323-2	Screw - HH (Europe)	2
14	68-6810	Assembly - Gear Box	1	31	93-9826	Guard - P.T.O. Shaft (Europe)	1
15	3253-21	Washer - Flat	4	32	93-7283	Decal - Danger (Europe)	1
15	3253-21	Washer - Flat (Europe)	6				
16	323-4	Screw - Cap Hex. Hd.	4				
17	63-9900	Pulley - Gear Box	1				

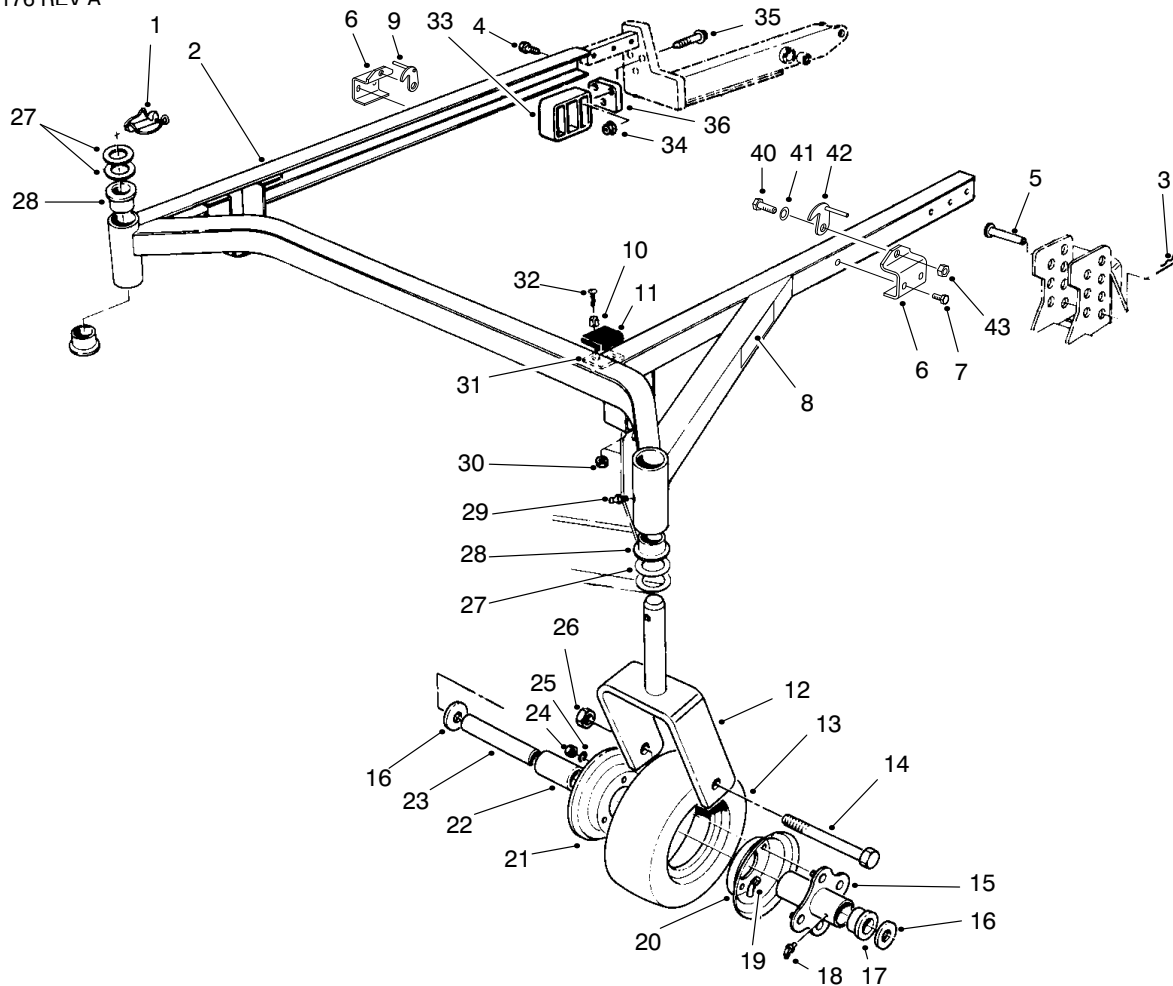

T-1249-2

CARRIER FRAME ASSEMBLY

Ref. No.	Part No.	Description	No. Used	Ref. No.	Part No.	Description	No. Used
1	283-71	Pin - Lynch	2	26	32153-5	Nut - Lock	2
2	83-4550	Frame - Deck Suspension (Incl. Ref. #28 & 29)	1	27	3-6781	Washer - Thrust	8
3	3290-355	Pin - Hair	4	28	94-1291	Bushing - Special	4
4	325-32	Screw - Cap Hex Hd.	6	29	302-5	Fitting - Grease	2
5	283-55	Pin - Clevis	4	30	3296-2	Nut - Lock	4
6	95-2718	Bracket - Latch (Europe)	2	31	42-6200	Cushion - Shim	A/R
7	32144-11	Screw - HH (Europe)	4	32	32122-28	Screw - Mach. Truss Hd.	4
8	68-8360	Decal - H.O.C.	1	33	83-4520	Cradle - Rear	2
8	93-7819	Decal - H.O.C. (Europe)	1	34	32128-40	Nut - Flange	6
9	95-2715	Retainer - Deck RH (Europe)	1	35	66-9302	Screw - Flange Hd.	6
10	40-9520	Spacer - Split	4	36	83-4580	Spacer	2
11	40-0330	Cushion - Rubber	2	37	76-3080	Lift Arm R.H. (Incl. Ref. #38 & 39)	1
12	68-8900	Fork - Castor, Front	2	*	76-3090	Lift Arm L.H. (Incl. Ref. #38 & 39)	1
13	68-8960	Tire	2	38	92-5648	Bushing	4
14	325-19	Screw - Cap Hex Hd.	2	39	302-62	Fitting - Grease	2
15	68-8940	Hub - Center	2	40	3214-2	Screw - HH (Europe)	2
16	3256-6	Washer - Thrust	4	41	3290-317	Washer - Wave (Europe)	2
17	62-5580	Bushing	4	42	95-2716	Retainer - Deck LH (Europe)	1
18	302-61	Fitting - Grease	2	43	3296-33	Nut - Lock (Europe)	2
19	68-8950	Tube w/Valve	2	*	68-8970	Castor Wheel (Incl. Ref. #13, 15, 17-22 & 24-25)	2
20	68-8920	Wheel Half - Female	2	*	95-3077	Castor Wheel Kit (2) (Incl. Ref. #13-26)	1
21	68-8930	Wheel Half - Male	2				
22	62-5570	Bearing - Roller	2				
23	68-8980	Bushing - Spanner	2				
24	3219-2	Nut - Hex.	8				
25	3253-4	Washer - Lock	8				

*Not Illustrated

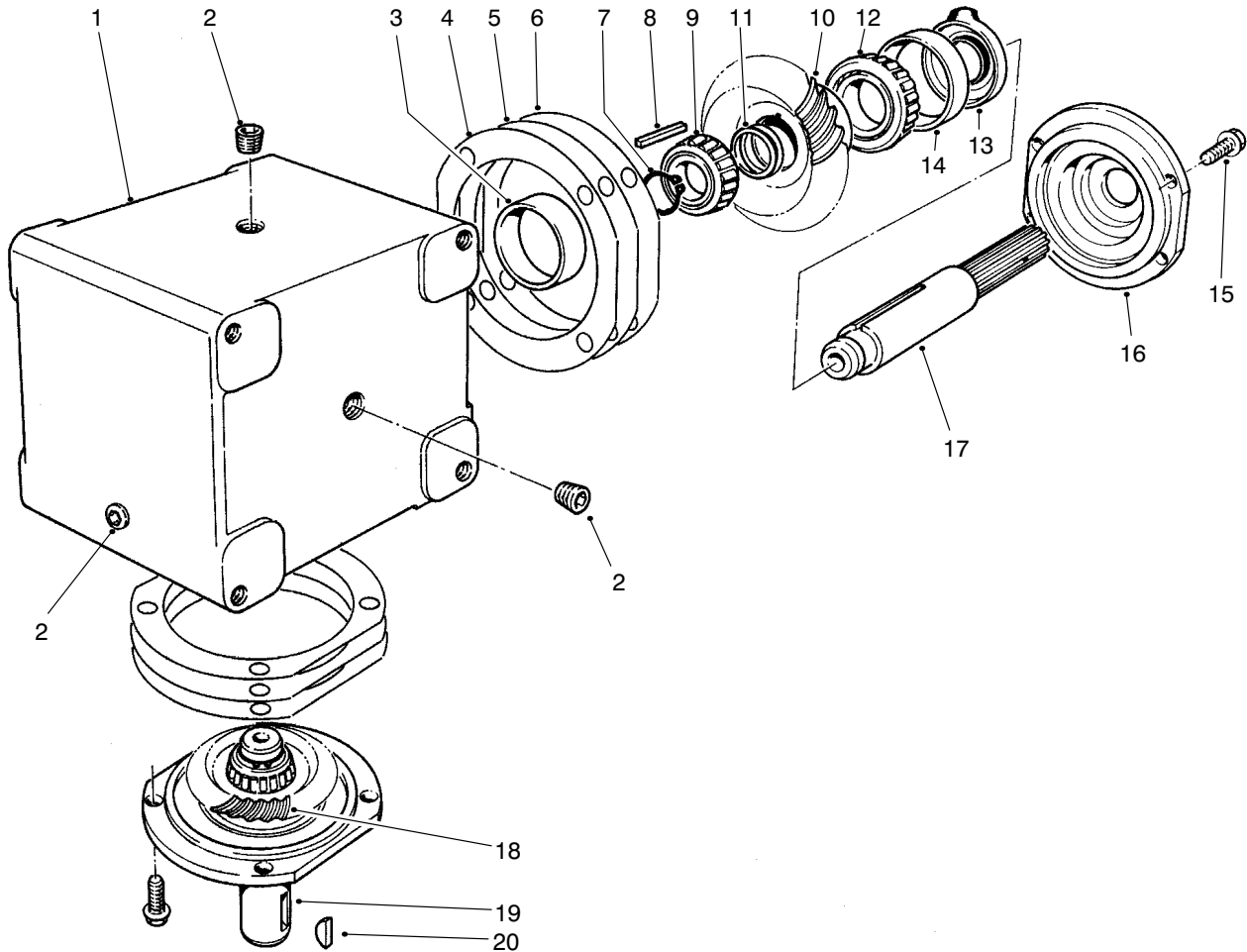

T-0977-1

GEAR BOX ASSEMBLY

Ref. No.	Part No.	Description	No. Used
1	68-7030	Housing	1
2	62-3490	Plug - Pipe (Solid)	4
3	62-3360	Cup - Bearing	2
4	62-3420	Gasket (.015)	A/R
5	62-3430	Gasket (.005)	A/R
6	62-3440	Gasket (.003)	A/R
7	68-7070	Ring - Retaining	2
8	62-3380	Key	2
9	62-3370	Cone - Bearing	2
10	68-7080	Gear	1

Ref. No.	Part No.	Description	No. Used
11	72-9370	Shim (.020)	2
12	62-3330	Cone - Gear	1
13	62-3400	Seal	2
14	62-3340	Cup - Bearing	2
15	62-3310	Screw - Cap	8
16	62-3410	Cap	2
17	68-7040	Shaft	1
18	68-7060	Gear	1
19	68-7050	Shaft	1
*	68-6810	Gear Box Assembly	1

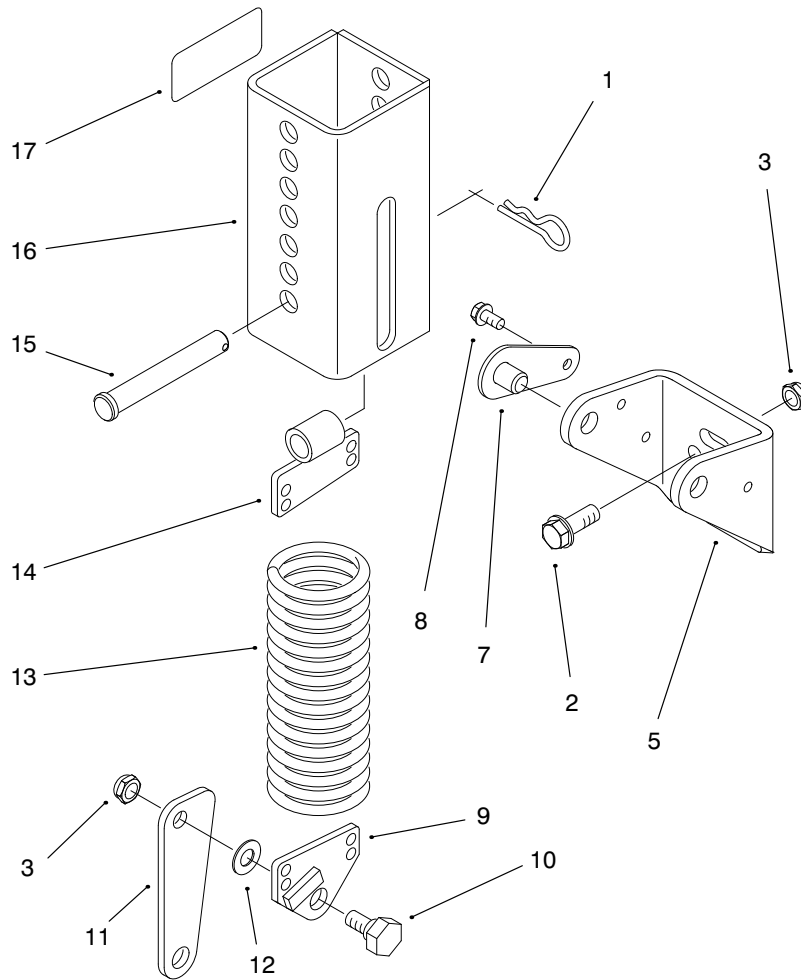

T-1219-1

COUNTER BALANCE

Ref. No.	Part No.	Description	No. Used
1	3290-355	Pin - Hair Cotter	1
2	3234-11	Screw - Hex. Flange Hd.	2
3	3296-44	Nut - Lock	2
5	66-8460	Bracket - Mounting	1
7	70-7920	Assembly - Pin, Lock	2
8	12-3270	Screw - Self Tapping	2
9	66-8420	End - Spring	1
10	46-3380	Bolt - Shoulder	2

Ref. No.	Part No.	Description	No. Used
11	66-8450	Link - Knee	1
12	3256-24	Washer - Flat	2
13	66-8390	Spring - Extension	1
14	70-7940	End - Spring	1
15	283-69	Pin - Clevis	1
16	70-7970	Assembly - Cover, Spring	1
17	55-4300	Decal - Caution	2
17	93-6696	Decal - Caution (Europe)	2

TORO PART NUMBER INDEX

3319-176 REV A

Part No.	Description	Pg. No.	Ref. No.	Qty.	Part No.	Description	Pg. No.	Ref. No.	Qty.
3-6781	Washer - Thrust	4	27	8	68-8900	Fork - Castor, Front	4	12	2
5-1077	Key - Square	1	15	1	68-8920	Wheel Half - Female	4	20	2
7-0081	Washer - Special	1	18	1	68-8930	Wheel Half - Male	4	21	2
7-4150	Washer	1	25	3	68-8940	Hub - Center	4	15	2
12-3270	Screw - Self Tapping	6	8	2	68-8950	Tube w/Valve	4	19	2
27-0870	Spindle Assembly	2	*	3	68-8960	Tire	4	13	2
27-0920	Spindle - Shaft	2	34	3	68-8970	Castor Wheel	4	*	2
27-0950	Spacer - Spindle Bearing	2	39	3	68-8980	Bushing - Spanner	4	23	2
27-0960	Bearing Set - Matched	2	37	3	68-9890	Cover - Gear Box	3	8	1
27-0970	Pulley	1	26	3	70-2560	Decal - Lube	3	13	1
27-0990	Blade	2	35	3	70-7920	Assembly - Pin, Lock	6	7	2
27-1160	V-Belt	1	22	1	70-7940	End - Spring	6	14	1
27-5970	Spacer - Matched Set	1	28	1	70-7970	Assembly - Cover, Spring	6	16	1
27-6140	Bushing - Taper Lock	3	19	1	72-9230	Base - Gear Box	3	2	1
27-7680	Ring - Deck Support	1	30	3	72-9240	Bracket - Extension	3	6	1
27-8580	Idler Socket	1	16	1	72-9330	Cover R.H.	3	1	1
28-9060	Plate - Idler	1	14	1	72-9340	Cover L.H.	3	23	1
29-4820	Roller	2	43	2	72-9361	Anti-Scalp Cup	2	36	3
29-5590	Pivot Bracket - Deflector	1	7	2	72-9370	Shim (.020)	5	11	2
36-1740	Roller - Deck	1	19	2	76-3080	Lift Arm R.H.	4	37	1
40-0330	Cushion - Rubber	4	11	2	76-3090	Lift Arm L.H.	4	*	1
40-0340	Shaft - Rear Roller	1	21	2	83-4520	Cradle - Rear	4	33	2
40-6230	Spring - Torsion	1	1	1	83-4550	Frame - Deck Suspension	4	2	1
40-6400	Shaft - Roller	2	41	1	83-4580	Spacer	4	36	2
40-9520	Spacer - Split	4	10	4	92-5648	Bushing	4	38	4
42-6200	Cushion - Shim	4	31	A/R	92-5816	Screw - Blade Bolt	2	38	3
43-8480	Decal - Danger	1	4	1	92-8779	Decal - Warning	2	50	1
44-5480	Blade - High Sail (Optional)	2	*	3	92-8792	Deck Assembly	2	40	1
46-3380	Bolt - Shoulder	6	10	2	93-6696	Decal - Caution (Europe)	6	17	2
46-8530	Bearing Assembly	2	*	3	93-6697	Decal - Lube (Europe)	3	13	1
51-3960	Decal - 52	2	52	1	93-7043	Retainer (Europe)	3	27	2
54-9220	Decal - Danger	2	51	1	93-7273	Decal - Danger (Europe)	2	49	2
55-4300	Decal - Caution	6	17	2	93-7283	Decal - Danger (Europe)	3	32	1
57-0690	Pin - Cotter	2	42	1	93-7316	Decal - Danger (Europe)	2	51	1
61-4160	Housing - Spindle	1	32	3	93-7808	Decal - Warning (Europe)	2	50	1
62-3310	Screw - Cap	5	15	8	93-7815	Decal - Danger (Europe)	1	4	1
62-3330	Cone - Gear	5	12	1	93-7818	Decal - Torque (Europe)	1	31	1
62-3340	Cup - Bearing	5	14	2	93-7819	Decal - H.O.C. (Europe)	4	8	1
62-3360	Cup - Bearing	5	3	2	93-7824	Decal - Danger (Europe)	1	8	2
62-3370	Cone - Bearing	5	9	2	93-7828	Decal - Danger (Europe)	1	6	1
62-3380	Key	5	8	2	93-8714	Grass Deflector Assembly	2	48	1
62-3400	Seal	5	13	2	93-9826	Guard - P.T.O. Shaft	3	31	1
62-3410	Cap	5	16	2	94-1291	Bushing - Special	4	28	4
62-3420	Gasket (.015)	5	4	A/R	95-2715	Retainer - Deck RH	4	9	1
62-3430	Gasket (.005)	5	5	A/R	95-2716	Retainer - Deck LH	4	42	1
62-3440	Gasket (.003)	5	6	A/R	95-2718	Bracket - Latch (Europe)	4	6	2
62-3490	Plug - Pipe (Solid)	5	2	4	95-3070	Blade & Belt Kit	2	*	1
62-5570	Bearing - Roller	4	22	2	95-3077	Castor Wheel Kit (2)	4	*	1
62-5580	Bushing	4	17	4	95-3078	Spindle Kit	2	*	3
63-8410	Washer	3	11	4	249-21	Latch - Draw	3	22	3
63-9750	ISO Mount - Gear Box	3	9	4	253-139	Seal - Wave	1	27	6
63-9900	Pulley - Gear Box	3	17	1	283-55	Pin - Clevis	4	5	4
65-5940	Pulley - Idler	1	17	1	283-69	Pin - Clevis	6	15	1
65-5950	Bushing - Pulley	2	45	1	283-71	Pin - Lynch	4	1	2
66-1340	Decal - Danger	1	8	2	302-2	Fitting - Grease	1	23	3
66-6380	Decal - Danger	1	6	1	302-5	Fitting - Grease	4	29	2
66-8390	Spring - Extension	6	13	1	302-61	Fitting - Grease	4	18	2
66-8420	End - Spring	6	9	1	302-62	Fitting - Grease	4	39	2
66-8450	Link - Knee	6	11	1	321-8	Screw - HH (Europe)	3	28	2
66-8460	Bracket - Mounting	6	5	1	322-4	Screw - Cap Hex. Hd.	3	7	2
66-9302	Screw - Flange Hd.	4	35	6	323-2	Screw - HH (Europe)	3	30	2
67-5360	Decal - Danger	2	49	2	323-4	Screw - Cap Hex. Hd.	3	16	4
68-6810	Assembly - Gear Box	3	14	1	325-19	Screw - Cap Hex Hd.	4	14	2
68-6810	Gear Box Assembly	5	*	1	325-32	Screw - Cap Hex Hd.	4	4	6
68-7030	Housing	5	1	1	3211-8	Screw - Cap Hex. Hd.	2	44	1
68-7040	Shaft	5	17	1	3211-15	Screw - Cap Hex. Hd.	2	47	2
68-7050	Shaft	5	19	1	3214-2	Screw - HH (Europe)	4	40	2
68-7060	Gear	5	18	1	3219-2	Nut - Hex.	4	24	8
68-7070	Ring - Retaining	5	7	2	3230-23	Bolt - Carriage	2	46	4
68-7080	Gear	5	10	1	3231-22	Bolt - Carriage	1	29	18
68-8340	Decal - Torque	1	31	1	3231-26	Bolt - Carriage	3	26	4
68-8360	Decal - H.O.C.	4	8	1	3231-27	Bolt - Carriage	3	20	4
68-8560	Bracket - Gear Box	3	10	2	3234-11	Screw - Hex. Flange Hd.	6	2	2

*Not Illustrated

