



<p>MODEL NO. 30243-40001 thru 80001 &amp; UP</p>	<p><b>OPERATOR'S MANUAL</b></p>
<p><b>GROUNDMASTER® 223D</b> 4 WHEEL DRIVE TRACTION UNIT</p>	

The GROUNDMASTER 223-D 4-Wheel Drive conforms to the American National Standards Institute's safety standards for riding mowers; thus, TORO proudly displays the ANSI safety seal.

To assure maximum safety, optimum performance, and to gain knowledge of the product, it is essential that you or any other operator of the mower read and understand the contents of this manual before the engine is ever started. Pay particular attention to the SAFETY INSTRUCTIONS highlighted by this symbol —



The safety alert symbol means CAUTION, WARNING or DANGER — personal safety instruction. Failure to comply with the instruction may result in personal injury.



# FOREWORD

The GROUNDSMASTER 223–D 4 Wheel Drive was developed to satisfy the demand for a maneuverable, intermediate size, turf maintenance rotary mower. The machine has advanced concepts in engineering, design and safety; and if maintained properly, it will give excellent service.

Since the GROUNDSMASTER 223–D 4 Wheel Drive is a high quality product, Toro is concerned about the future use of the machine and the safety of the user. Read this manual to familiarize yourself with the proper set up, operation, and maintenance instructions. The major sections of this manual are:

1. Safety Instructions
2. Set Up Instructions
3. Before Operating
4. Operating Instructions
5. Maintenance

Certain information in this manual is emphasized. DANGER, WARNING and CAUTION identify personal safety related information. IMPORTANT identifies mechanical information demanding special attention. Be sure to read the directive because it deals with the possibility of damaging a part or parts of the machine. NOTE identifies general information worthy of special attention.

If help concerning set up, operation, maintenance or safety is ever needed, contact a local Authorized Toro Distributor. In addition to genuine Toro replacement parts, the distributor also has optional equipment from the complete line of Toro turf care equipment. Keep your Toro all Toro — buy genuine Toro replacement parts and accessories.

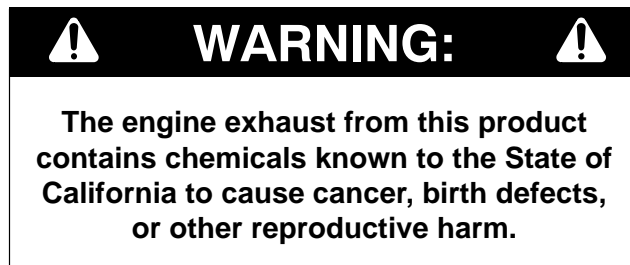

## SPARK ARRESTER

Because in some areas there are local, state or federal regulations requiring that a spark arrestor muffler be used on the engine of this mower, a spark arrestor screen is available as an option. If a spark arrestor muffler is required, order the following part from you Authorized Toro Distributor.

(1) 75–6880 Spark Arrestor Screen

This part is certified to meet the requirements of USDA Forest Service Standard No. 5100–1A.

When the mower is used or operated on any California forest, brush or grass covered land, a properly operating spark arrester must be attached to the muffler. The operator is violating state law, Section 442 Public Resources Code if a spark arrester is not used.

Whenever you have questions or need service, contact your local authorized Toro Distributor. In addition to having a complete line of accessories and professional turf care service technicians, the distributor has a complete line of genuine TORO replacement parts to keep your machine operating properly. Keep your TORO all TORO. Buy genuine TORO parts and accessories.

# TABLE OF CONTENTS

<b>SAFETY INSTRUCTIONS</b> .....	4	Servicing Air Cleaner Filter .....	23
<b>SAFETY AND INSTRUCTION DECALS</b> .....	6	Inspecting Filter Element .....	24
<b>SPECIFICATIONS</b> .....	7	Cleaning Radiator And Screen .....	24
<b>LOOSE PARTS CHART</b> .....	8	Changing Engine Oil And Filter .....	24
<b>SET-UP INSTRUCTIONS</b> .....	8	Servicing Fuel System .....	24
<b>BEFORE OPERATING</b> .....	12	Bleeding Air From Injectors .....	26
Check Engine Oil .....	12	Servicing Engine Belts .....	26
Check Cooling System .....	12	PTO Belt .....	27
Check Hydraulic System Fluid .....	13	PTO Clutch Adjustment .....	27
Fill Fuel Tank .....	14	Changing Coolant In Cooling System .....	28
Check Rear Axle Lubricant .....	14	Adjusting Transmission For Neutral .....	28
<b>CONTROLS</b> .....	15	Changing Hydraulic Oil And Filter .....	28
<b>OPERATING INSTRUCTIONS</b> .....	17	Adjusting Service Brakes .....	29
Starting and Stopping .....	17	Changing Rear Axle Lubricant .....	29
Bleeding Fuel System .....	17	Rear Wheel Toe-in .....	30
Checking Interlock System .....	18	Adjusting Steering Stops .....	30
Operating Characteristics .....	18	Servicing Battery .....	30
Pushing Or Towing Traction Unit .....	19	Wiring Harness Service .....	30
<b>DAILY MAINTENANCE CHECKLIST</b> .....	20	Fuses .....	30
<b>LUBRICATION</b> .....	21	<b>ELECTRICAL SCHEMATIC</b> .....	31
Greasing Bearings And Bushings .....	21	<b>HYDRAULIC SCHEMATIC</b> .....	32
<b>SERVICE INTERVAL CHART</b> .....	22	<b>MAINTENANCE SCHEDULE</b> .....	33
<b>MAINTENANCE</b> .....	23	<b>PREPARATION FOR SEASONAL STORAGE</b> ...	34
General Air Cleaner Maintenance .....	23	<b>PRODUCT IDENTIFICATION</b> .....	35
Servicing Dust Cup and Baffle .....	23	<b>THE TORO PROMISE</b> .....	Back Cover



# SAFETY INSTRUCTIONS

The **GROUNDMASTER 223–D 4 Wheel Drive** was tested and certified by **TORO** for compliance with the **B71.4-1990** specifications of the **American National Standards Institute**. Although hazard control and accident prevention partially are dependent upon the design and configuration of the machine, these factors are also dependent upon the awareness, concern, and proper training of the personnel involved in the operation, transport, maintenance, and storage of the machine. Improper use or maintenance of the machine can result in injury or death. To reduce the potential for injury or death, comply with the following safety instructions.

## BEFORE OPERATING

1. Read and understand the contents of this manual before starting and operating the machine. Become familiar with the controls and know how to stop the machine and engine quickly. A free replacement manual is available by sending the complete model and serial number to:

The Toro Company  
8111 Lyndale Avenue South  
Minneapolis, Minnesota 55420–1196.

2. Never allow children to operate the machine. Do not allow adults to operate machine without proper instruction. Only trained operators who have read this manual should operate this machine.

3. Never operate the machine when under the influence of drugs or alcohol.

4. Remove all debris or other objects that might be picked up and thrown by the blades or fast moving components from other attached implements. Keep all bystanders away from operating area.

5. Keep all shields, safety devices and decals in place. If a shield, safety device or decal is defective, illegible or damaged, repair or replace it before operating the machine. Also tighten any loose nuts, bolts or screws to ensure machine is in safe operating condition.

6. Always wear substantial shoes. Do not operate machine while wearing sandals, tennis shoes, sneakers or when barefoot. Do not wear loose fitting clothing that could get caught in moving parts and possibly cause personal injury. Wearing safety glasses, safety shoes, long pants and a helmet is advisable and required by some local ordinances and insurance regulations.

7. Check carefully for overhead clearances before driving under any objects and do not contact them.

8. Check interlock switches daily for proper operation (Refer To Checking Interlock Switches, Page 18). Do not rely entirely on safety switches -shut off engine before getting off seat. If a switch fails, replace it before

operating the machine. The interlock system is for your protection, so do not bypass it. Replace all interlock switches every two years. Interlock switches should be adjusted so:

- A. Engine cannot be started unless traction pedal is released (neutral position)—and PTO lever is DISENGAGED (off position).
- B. Engine stops if operator gets off seat when traction pedal is depressed.
- C. Engine stops if operator gets off seat when PTO lever is ENGAGED (on position).

9. Grass deflectors must be installed in lowest position on side discharge units.

10. Since diesel fuel is highly flammable, handle it carefully:

- A. Use an approved fuel container.
- B. Do not remove fuel tank cap while engine is hot or running.
- C. Do not smoke while handling fuel.
- D. Fill fuel tank outdoors and only to within an inch from the top of the tank, not the filler neck. Do not overfill.
- E. Wipe up any spilled fuel.

## WHILE OPERATING

11. Sit on the seat when starting and operating the machine.

12. Before starting the engine:

- A. Engage the parking brake.
- B. Make sure traction pedal is in NEUTRAL and PTO switch in OFF position.
- C. After engine is started, release parking brake and keep foot off traction pedal. Machine must not move. If movement is evident, the neutral return mechanism is adjusted incorrectly; therefore, shut engine off and adjust until machine does not move when traction pedal is released.

13. Seating capacity is one person. Therefore, never carry passengers.

14. Do not run engine in a confined area without adequate ventilation. Exhaust fumes are hazardous and could possibly be deadly.

15. Operator must be skilled and trained in how to drive on hillsides. Failure to use caution on slopes or hills may cause loss of control and vehicle to tip or roll possibly resulting in personal injury or death.

16. Traverse slopes carefully. Do not start or stop suddenly when traveling uphill or downhill.

17. This product may exceed noise levels of 85 dB(A) at the operator position. Ear protectors are recommended for prolonged exposure to reduce the potential of permanent hearing damage.



## SAFETY INSTRUCTIONS

**18.** Using the machine demands attention and to prevent loss of control:

- A. Operate only in daylight or when there is good artificial light.
- B. Drive slowly. Avoid sudden stops and starts.
- C. Watch for holes or other hidden hazards.
- D. Look behind machine before backing up.
- E. Do not drive close to a sand trap, ditch, creek or other hazard.
- F. Reduce speed when making sharp turns and turning on a hillside.
- G. The cutting deck must be lowered when going down slopes for steering control.

**19.** When operating 4 wheel drive machine, always use the seat belt and ROPS together and have seat pivot retaining pin installed.

**20.** Be certain that the seat belt can be removed quickly if the machine is driven into ponds of water.

**21.** If engine stalls or loses headway and cannot make it to the top of a slope, do not turn machine around. Always back slowly straight down the slope.

**22.** Never raise the cutting unit or other attached implement while the blades or other parts are rotating.

**23.** The grass deflector must always be installed and in the lowest position on the cutting unit. This product is designed to drive objects into the ground where they lose energy quickly in grassy areas. **DON'T TAKE AN INJURY RISK!** When a person or pet appears unexpectedly in or near the mowing area, **STOP MOWING.** Careless operation, combined with terrain angles, ricochets, or improperly positioned guards can lead to thrown object injuries. Do not resume mowing until area is cleared.

**24.** Do not touch engine, muffler or exhaust pipe while engine is running or soon after it is stopped. These areas could be hot enough to cause burns.

**25.** If cutting deck strikes a solid object or vibrates abnormally, stop immediately, turn engine off, set parking brake and wait for all motion to stop. Inspect for damage. If damaged, repair or replace any components before operating.

**26.** Before getting off the seat:

- A. Move traction pedal to neutral position and remove foot from pedal.
- B. Set the parking brake and turn the PTO switch OFF.
- C. Shut the engine OFF and remove key from ignition switch. Wait for all machine movement to stop before getting off the seat.

## MAINTENANCE

**27.** Before servicing or making adjustments, stop engine and remove key from the switch.

**28.** Make sure machine is in safe operating condition by keeping all nuts, bolts and screws tight.

**29.** Make sure all hydraulic line connectors are tight, and all hydraulic hoses and lines are in good condition before applying pressure to the system.

**30.** Keep body and hands away from pin hole leaks or nozzles that eject high pressure hydraulic fluid. Use cardboard or paper to find hydraulic leaks. Hydraulic fluid escaping under pressure can penetrate skin and cause injury. Fluid accidentally injected into the skin must be surgically removed within a few hours by a doctor familiar with this form of injury or gangrene may result.

**31.** Before disconnecting or performing any work on the hydraulic system, all pressure in system must be relieved by stopping engine and lowering implement to the ground.

**32.** If major repairs are ever needed or assistance is desired, contact an Authorized Toro Distributor.

**33.** To reduce potential fire hazard, keep engine area free of excessive grease, grass, leaves and dirt. Never wash a warm engine or electrical connections with water.

**34.** If engine must be running to perform maintenance or an adjustment, keep hands, feet, clothing and other parts of the body away from cutting deck and other moving parts. Keep all bystanders away.

**35.** Do not overspeed the engine by changing governor setting. To assure safety and accuracy, have an Authorized Toro Distributor check maximum engine speed.

**36.** Periodically inspect the roll bar and roll bar mounting. Repair, as necessary. Never modify roll over protection frames or structures because they are specifically designed, sized, located and tested for injury protection. If a rollover occurs, a modified ROPS will not provide adequate protection.

**37.** Shut engine off before checking or adding oil to the crankcase.

**38.** At the time of manufacture, the machine conformed to the safety standards for riding mower. To assure optimum performance and continued safety certification of the machine, use genuine Toro replacement parts and accessories. Replacement parts and accessories made by other manufacturers may result in non-conformance with the safety standards, and the warranty may be voided.



# SAFETY AND INSTRUCTION DECALS

The following safety and instruction decals are affixed to the traction unit. If any decal becomes illegible or damaged, install a new decal. Part numbers are listed below and in your Parts Catalog.

**CAUTION**  
 MAINTAIN WHEEL FASTENER TORQUE AT 45-55 ft.-lb.  
 SEE OPERATORS MANUAL FOR INSTRUCTIONS. 67-1720

ON FRAME IN  
FRONT OF DRIVE WHEELS  
(Part No. 67-1720)

**WARNING**  
 TO REDUCE THE POSSIBILITY OF ACCIDENTS, INJURY OR DEATH:  
 CHECK PERFORMANCE OF ALL INTERLOCK SWITCHES DAILY.  
 SEE OPERATOR'S MANUAL FOR INSTRUCTIONS. DO NOT DEFEAT  
 INTERLOCK SYSTEM. IT IS FOR YOUR PROTECTION. 67-1710

LEFT SIDE SEAT FRAME  
(Part No. 67-1710)

**WARNING**  
 PTO universal shaft is attached to  
 traction unit. DO NOT ENGAGE PTO  
 without first removing universal  
 shaft or coupling it to a suitable  
 implement.

**OIL**  
 10W30  
 OR  
 10W40

FRONT BULKHEAD  
(Part No. 53-4430)

TAG ON PTO SWITCH  
(Part No. 52-1420)

STARTING INSTRUCTIONS (SEE OPERATOR'S MANUAL)

1. DISENGAGE POWER TAKE-OFF.	4. SET THROTTLE CONTROL - FULL OPEN.
2. PLACE TRACTION DRIVE IN NEUTRAL POSITION.	5. PUSH GLOW PLUG SWITCH TO ON POSITION AND PREHEAT.
3. DEPRESS BRAKE PEDAL.	6. TURN KEY TO START POSITION.

TO STOP, TURN KEY TO OFF POSITION AND REMOVE KEY. 67-1710

SEAT PLATE FRONT  
(Part No. 92-5773)

**DANGER**

LOS OPERADORES DEBEN ESTAR MUY BIEN CAPACITADOS EN UNA OPERACION SEGURA.

TO MINIMIZE THE RISK OF ACCIDENTS, INJURY, OR DEATH:

- BEFORE LEAVING OPERATOR'S POSITION:
  - MOVE TRANSMISSION TO NEUTRAL.
  - SET PARKING BRAKE
  - DISENGAGE POWER TAKE-OFF
  - SHUT OFF ENGINE
- REMOVE IGNITION KEY
- KEEP ALL GUARDS AND COVERS IN PLACE.
- WAIT FOR ALL MOVEMENT TO STOP BEFORE SERVICING.
- STOP ENGINE BEFORE LEAVING SEAT, ADDING FUEL OR LIFTING HOOD.
- KEEP PEOPLE AND PETS A SAFE DISTANCE AWAY.
- ALWAYS USE SEAT BELT AND ROLL BAR TOGETHER AND HAVE SEAT PIVOT RETAINING PIN INSTALLED.
- GO SLOW AND AVOID SHARP TURNS ON SLOPES TO AVOID ROLLOVER.
- DECK MUST BE LOWERED WHEN GOING DOWN SLOPES FOR STEERING CONTROL.
- OPERATOR MUST BE SKILLED AND TRAINED IN SLOPE OPERATION - READ OPERATORS MANUAL.

92-5774

ON TOOL BOX  
(Part No. 92-5774)

**CAUTION**  
 1 INCH (25 mm)  
 FILL FUEL TANK TO ONE  
 INCH BELOW FILLER NECK.  
 DO NOT OVERFILL. 27-7300

TOOL BOX REAR  
(Part No. 27-7310)

**GEAR LUBE**  
**SAE 80W-90**  
**API GL-5** 70-2560

REAR AXLE  
(Part No. 70-2560)

TRACTION PEDAL FORWARD

REVERSE

**NO STEP**  
 USE OTHER SIDE

**CAUTION**  
 TURN OFF PTO BEFORE RAISING IMPLEMENT TO TRANSPORT POSITION. DO NOT OPERATE IMPLEMENT IN TRANSPORT POSITION. 92-5772

FLOAT

LOWER

RAISE

LIFT CONTROL

THROTTLE

92-5770

RIGHT SIDE OF PLATFORM  
(Part No. 92-5772)

**CAUTION**  
 DO NOT USE STARTING FLUID  
 83-9150

AIR CLEANER  
(Part No. 83-9150)

**WARNING**

77-2000

ON FAN SHROUD  
(Part No. 76-8750)

**DIESEL ONLY**

NEAR FUEL CAP  
(Part No. 52-1321)

**GM 223-D QUICK REFERENCE AID**

**CHECK/SERVICE**

- Oil levels (Engine/Trans.)
- Coolant level
- Tire pressure
- Belts (Fan, Alt, PTO)
- Fuel - Diesel Only
- Battery
- Grease, Lube points
- Radiator screen
- Air cleaner
- Electric clutch gap .015-.030
- PTO Belt tension
- Water separator

**FILTERS**

PART NO.	
A. Air	27-7110
B. Fuel Pump	43-2550
C. Fuel line	63-8300
D. Trans. Oil	23-2300
E. Engine Oil	67-4330

**FLUID SPECIFICATIONS** \*See operator's manual for initial changes.

	TYPE > 32° F 0°C	TYPE < 32° F 0°C	CAPACITY	*CHANGE INTERVALS
Engine oil	SAE 30 CD	SAE 10W-30 CD	3.9 QT. <sup>liters</sup>	50 hrs. <sup>liter</sup> 100 hrs.
Trans oil	SAE 10W-30 SF CC, CD	TYPE F or FA Trans. Fluid	6 QT.	250 hrs. <sup>liter</sup> 250 hrs.
Fuel	NO. 2 - D	NO. 1 - D	8.5 GAL.	<sup>liter</sup> 400 hrs.
Coolant	50/50 MIX Ethylene glycol anti-freeze/Water		7 QT.	2 years

84-1960

INSIDE TOOL BOX COVER  
(Part No. 84-1960)

# SPECIFICATIONS

## Engine:

Manufacturer — Mitsubishi.  
Horsepower — 22 (16 Kw) @ 3000 RPM.  
Torque — 40 ft-lb (54.2 N-m) @ 2400 RPM.  
Displacement — 58.1 cu in. (952 cc).  
Crankcase Capacity — 3.8 qt. (3.6 L).  
Governor — Mechanical.  
Governor Limit — 3100-3250 RPM.  
Idle Speed — 1700 RPM.

**Air Cleaner:** Donaldson heavy duty with precleaner. Remote mounted.

**Fuel Tank Capacity:** 8.5 gal. (32 l).

**Fuel Filter/Water Separator:** 3 micron spin-on type element. Replaceable (Toro Part No. 63-8300).

**Fuel Pump:** 12 volt electric (transistor type) w/replaceable fuel filter (Toro Part No. 43-2550).

## Cooling System:

Radiator — Approx. 6 qt (5.7 l) capacity.  
Expansion Tank — Remote mounted; 1 qt (0.946 l) capacity. System contains a 50/50 mix of ethylene glycol anti-freeze and water.

**Electrical:** Battery — 12 volt, BCI group size 26,530 Amp at 0° F. 35 amp alternator with regulator/rectifier.

**Drive Coupling:** Transmission driven by steel shaft with flexible rubber couplings at each end.

## Transmission;

Manufacturer & Type — Sundstrand hydrostatic, Type U15.  
Normal Charge Pressure — 70-150 psi (483-1034 kPa).  
Implement Relief Setting — 700-800 psi (4 826 - 5 516 kPa).

**Hydraulic Filter:** 25 micron mounted directly to transmission. Replaceable (Toro Part No. 23-2300).

**Drive Axle:** Manufacturer — Dana Corp., Model GT-20. Axle serves as a hydraulic fluid reservoir and mates directly with the transmission. Approximately 5 qt (4.7 l) capacity. Mechanical rear axle is coupled to front axle by a drive shaft and overrunning clutch.

**Brakes:** Mechanical drum type, 7 in. (17.8 cm) dia. x 1-3/4 in. (45 mm) wide. Individually controlled by two pedals connected by cable and conduit for steering assist. Pedals may be latched together for two wheel braking. Lever provided for parking brake.

## Tires, Wheels, Pressure:

Front Tires — 23 x 8.50 - 12  
Rear Tires — 18 x 6.50 - 8  
All tires 4 ply rating, tubeless type.  
Pressure — 20 (138 kPa).

**Steering:** 13 in. (33 cm) steering wheel. TRW power steering valve.

**Main Frame:** Frame is welded, formed steel.

**Instrumentation:** Fuel gauge, water temperature gauge, hour meter and warning lights for high temperature shutdown, oil pressure, amperage and glow plug are mounted on the console.

**Controls:** Throttle, PTO switch, parking brake, implement lift, ignition switch and glow plug switch are all hand-operated. Forward/reverse traction pedal and turning brakes are foot operated.

**PTO Drive:** Splined PTO shaft is clutched by a torque-teamed HA Section, spring tensioned V-belt directly from engine output shaft. PTO shaft engaged by electric clutch/brake assembly. PTO speed — 2200 RPM @ 3250 RPM engine speed.

**Implement Connection** — Universal joint and telescoping shaft assembly.

**Lift Cylinders:** Two, with 2 in. (51 mm) bore, 3.5 in. (89 mm) stroke.

**Interlock Switches:** Prevents engine starting if traction pedal or PTO switch are engaged. Stops engine if operator leaves seat with either traction pedal or PTO switch engaged.

## Dimensions and Weight (approx):

Traction Unit w/Standard Seat

Length:	82 in.
Width: (Rear Wheels)	47 in.
Height:	50 in.
Weight:	1120 lb

## OPTIONAL EQUIPMENT

**52" Side Discharge Cutting Unit**—Model No. 30555

**52" Rear Discharge Cutting Unit**—Model No. 30568

**62" Side Discharge Cutting Unit**—Model No. 30564

**62" Guardian Recycler Cutting Unit**—Model No. 30569

**72" Side Discharge Cutting Unit**—Model No. 30575

**48" V-Plow Kit** — Model No. 30750

**V-Plow Mounting Kit** — Model No. 30749. Required with 30750 V-Plow. 11-0390 Tire Chains recommended.

**Arm Rest Kit** — Model 30707. Fits Models 30769, 30772 Seat Kits.

**Rear Discharge Shield Kit** — Model No. 30567.

**Rear Weight Box Kit** — Part No. 24-5780.

**Grass Collection System** — Model No. 30502, 52" Blower Kit (for Model 30555 deck) or Model 30503 62" Blower Kit (for Model 30564 deck) can be used with Model No. 30505, 15 cu. ft. Hopper Kit.

Note: Model 30504, 9 cu. ft. Hopper Kit cannot be used on a 30243, 4 wheel drive traction unit.

# SPECIFICATIONS

**Wide Tires w/rim:** 23 x 10.5 - 12 — Part No. 62–7020.

**Wheel Weights:** — Part No. 11–0440. 50 lb (23 kg).

**Weight Kit–20 lb.** — Part No. 92–8763.

**Rear Weight Kit** — Part No. 24–5780. 70 lb (31.8 kg).

**Tire Chains** — Part No. 11–0390.

**Standard Seat Kit** — Model No. 30769.

**Deluxe Seat Kit** — Model No. 30772.

Refer to Specifications section of individual Cutting Unit Operator's Manuals for cutting unit options.

## LOOSE PARTS CHART

**Note:** Use this chart as a checklist to make sure all parts have been received. Without these parts, total set-up cannot be completed.

DESCRIPTION	QTY.	USE
Steering Wheel Foam Seal Nut Screw Cap	1 1 1 1 1	Install Steering Wheel.
Seat Belt Flatwasher Capscrew 7/16 - 20 x 1 in. Lockwasher 7/16	1 2 2 2	Install Seat Belt
Manual Tube R-Clamp	1 2	Install on right underside of seat.
ROPS	1	Mount to Frame
Roll Pin Capscrew 5/16 - 18 x 1–3/4 in. Locknut 5/16 - 18	1 2 2	Secure universal shaft to implement.
Operator's Manual (Traction Unit) Parts Catalog	2 1	
Registration Card	1	Fill out and return to Toro

## SET-UP INSTRUCTIONS



### WARNING

PTO universal shaft is attached to traction unit frame. DO NOT ENGAGE PTO without first removing universal shaft or coupling it to a suitable implement.

### INSTALL REAR WHEELS

1. Remove screws from wheel hubs. Mount wheels and torque screws to 45-55 ft-lbs.

### INSTALL STEERING WHEEL

1. Remove jam nut from steering shaft. Slide foam seal and steering wheel onto steering shaft.

2. Secure steering wheel to shaft with jam nut and tighten it to 10–15 ft-lb.

3. Install cap to steering wheel with screw.

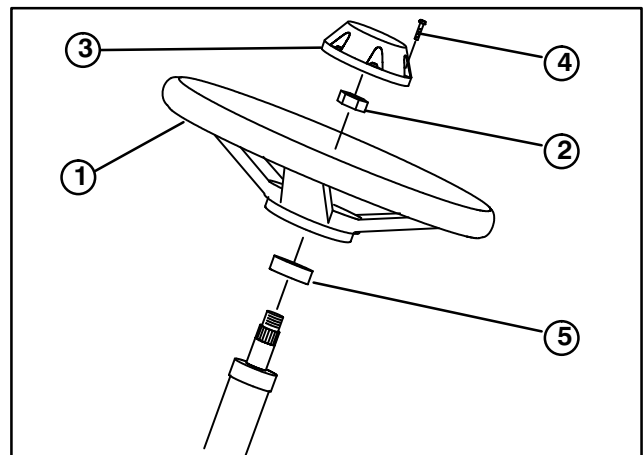

Figure 1

- |                   |              |
|-------------------|--------------|
| 1. Steering wheel | 4. Screw     |
| 2. Jam nut        | 5. Foam seal |
| 3. Cap            |              |

### INSTALL SEAT

The Groundsmaster 223–D 4 Wheel Drive is shipped without the seat assembly. Either optional Seat Kit, Model No. 30769 or 30772 must be installed.

# SET-UP INSTRUCTIONS

## Seat Kit, Model No. 30769, Standard Seat:

1. Attach "U" springs to seat mounting brackets using bolts and locknuts as shown in figure 2.

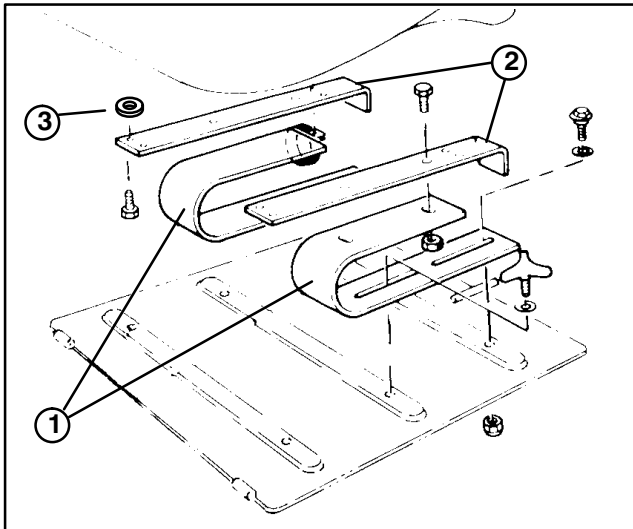

**Figure 2**

- 1. "U" spring
- 2. Seat mounting bracket
- 3. Spacer

2. Secure seat mount assemblies to bottom of seat with (4) flange head capscrews and (4) spacers. (Fig. 2). Spacers to be positioned between seat and seat mount.

**Note:** Mount the bracket in the forward set of tapped mounting holes in seat.

3. Remove hair pin cotter and pull back on locking spring flap to pivot mounting plate forward (Fig. 3).

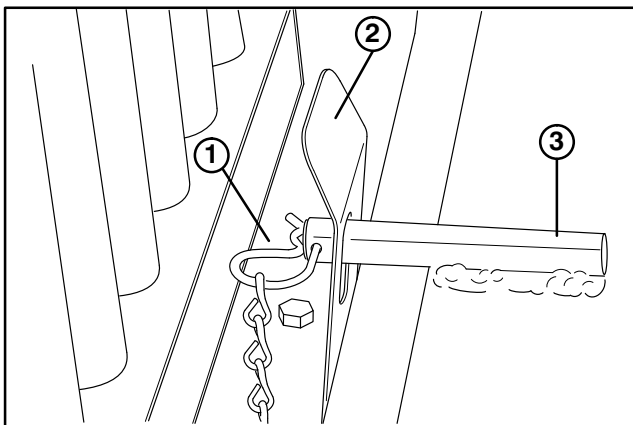

**Figure 3**

- 1. Hair pin
- 2. Lock spring flap
- 3. Seat mounting plate

4. Hold mounting plate in upright position with support rod (Fig. 4).

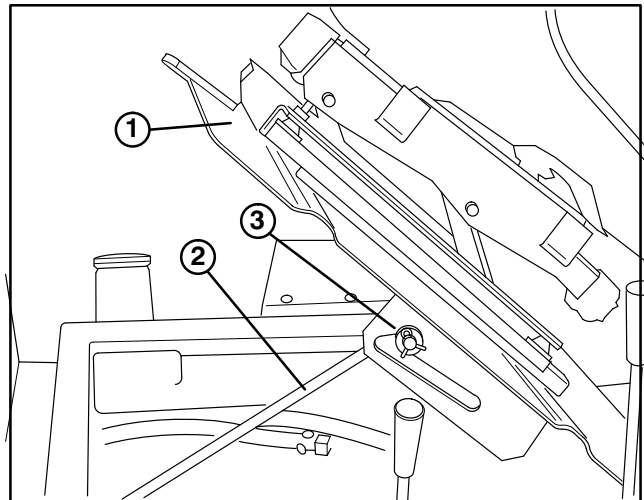

**Figure 4**

- 1. Mounting plate
- 2. Support rod
- 3. Indent

5. Mount seat and spring assembly to rear holes in seat mounting plate with two shoulder bolts, small I.D. flat washers and locknuts (Fig. 2 & 5).

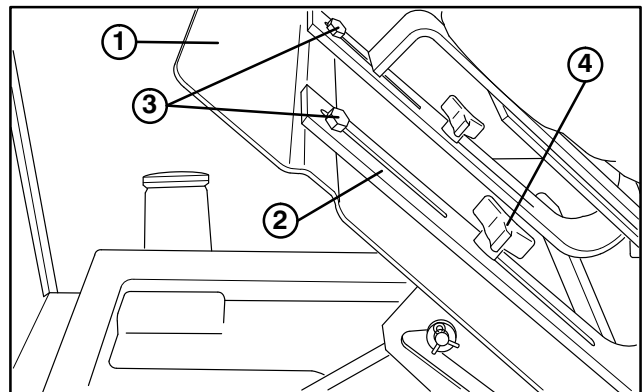

**Figure 5**

- 1. Mounting plate
- 2. Seat spring
- 3. Shoulder bolt with washer and locknut (2)
- 4. Adjustment handle (2)

6. Secure front slot of seat springs to traction unit front mounting holes with adjustment handles and flatwashers (Fig. 2 & 5).

7. Adjust seat to desired operating position. Loosen adjustment handles, slide seat fore or aft in slotted holes and tighten adjustment handles to secure in place.

## Seat Kit, Model No. 30722, Deluxe Seat:

1. Position threaded mounting studs of seat suspension into holes in seat mounting plate.

2. Remove hair pin cotter and pull back on locking spring flap to pivot mounting plate forward (Fig. 3).

3. Hold mounting plate in upright position with support rod (Fig. 4).

# SET-UP INSTRUCTIONS

4. Secure seat suspension to seat mounting plate with (4) flange locknuts (Fig. 6 & 7).

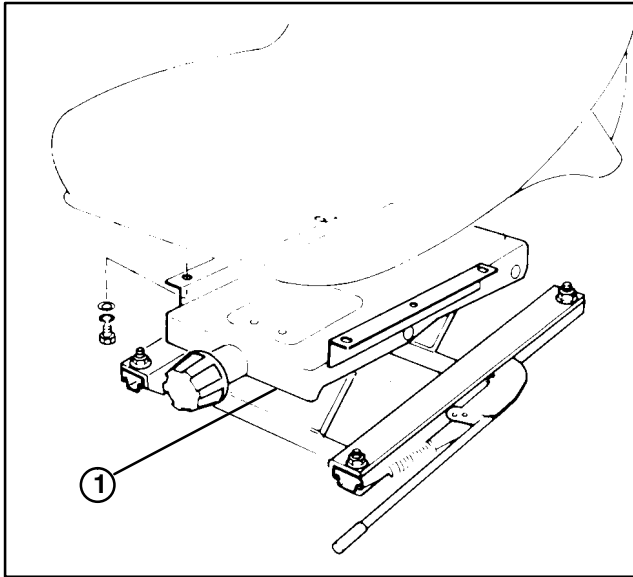

**Figure 6**  
1. Seat suspension

5. Mount seat to seat suspension with (4) capscrews, lockwashers and flatwashers (Fig. 6 & 7).

6. Adjust seat for operator's comfort and weight. To adjust seat fore and aft, pull handle on left side of seat assembly outward (Fig. 7). Release handle to lock seat position. To adjust for operator's weight, turn spring tension knob; clockwise to increase tension, counterclockwise to decrease spring tension (Fig. 7).

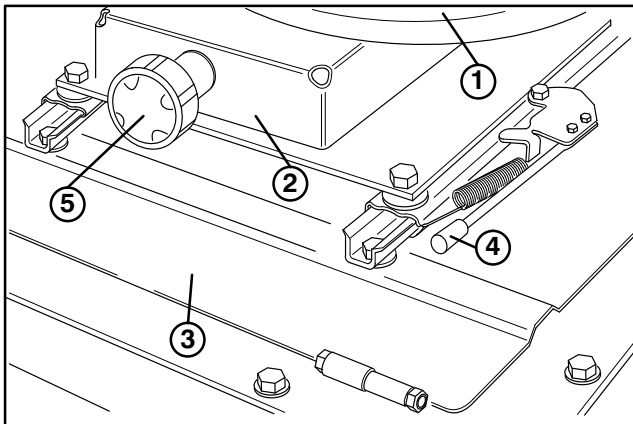
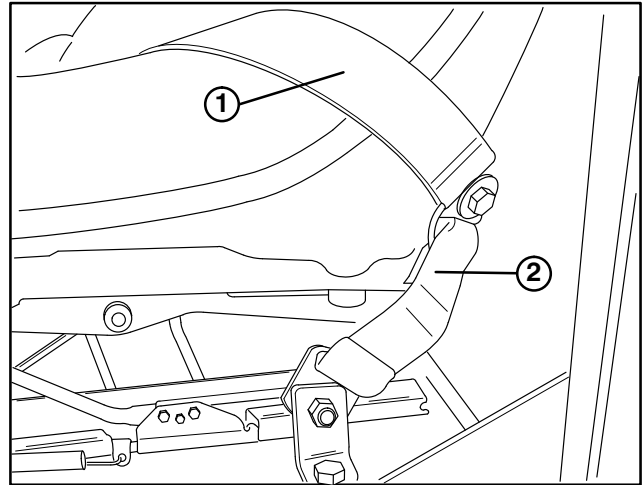

**Figure 7**

1. Seat	4. Forward/backward handle
2. Suspension assembly	5. Spring tension knob
3. Mounting plate	

## INSTALL SEAT BELTS

1. Install tether straps and each end of seat belt to holes in back of seat with (2) 7/16 x 20 - 1" lg. capscrews, 7/16 flatwashers and 7/16 lockwashers. Tighten securely. Latch side of belt to be mounted to left side of seat.

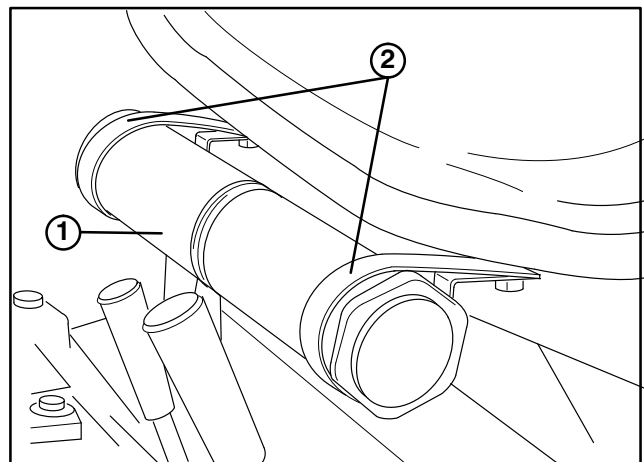

**Figure 8**  
1. Seat Belts  
2. Tether strap

**NOTE:** When operating machine, always use the seat belt and ROPS together.

## INSTALL MANUAL TUBE

1. Loosely mount (2) R-clamps to outer holes in right side of seat with (2) capscrews and flatwashers (supplied with seat kit) (Fig. 9).



**Figure 9**  
1. Manual tube  
2. R-clamps

2. Install manual tube into R-clamps, insert manual into tube and thread cap into tube (Fig. 9). Tighten capscrews.

# SET-UP INSTRUCTIONS

## INSTALL ROPS

1. Remove (2) 1/2–13 x 1–1/4" lg. capscrews, 1/2" flatwashers, 1/2" lockwashers and 1/2–13 nuts secured to mounting brackets on each side of machine and (2) 1/2–13 x 1–1/4" lg. and (2) 1/2–13 x 3–1/2" lg. capscrews, (2) 1/2" flatwashers (2) 1/2" lockwashers and (2) 1/2–13 nuts secured to each leg of ROPS frame.
2. Lower ROPS frame onto mounting brackets, aligning mounting holes.
3. Secure each side of roll bar to mounting brackets with capscrews, flatwashers and lockwashers previously removed (Fig. 4). Torque fasteners to 50-60 ft–lbs.

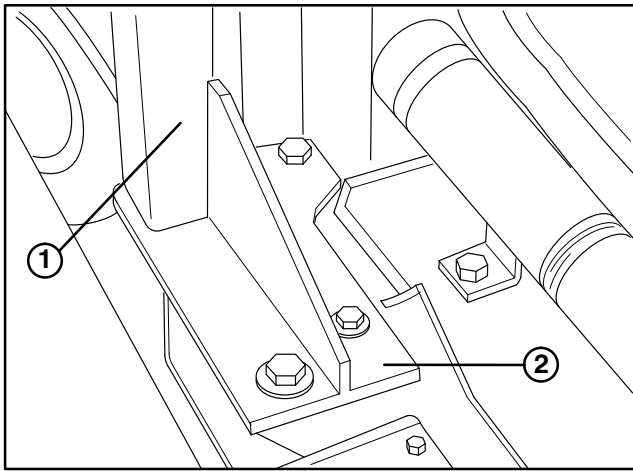

**Figure 10**

1. ROPS
2. Mounting bracket

**NOTE:** When operating machine, always use the seat belt and ROPS together.

## CONNECT BATTERY

1. Lift engine cover. Check to see that the battery is securely fastened in place (Fig. 11).
2. Check battery charge with a hydrometer. If battery needs charging, be sure one of the battery cables is disconnected from the battery before the charger is connected.
3. Remove tape from battery cables and secure the cables to the proper battery post. The positive (+) red cable goes to the positive post and the negative (–) black cable goes to the negative post on the battery.



## WARNING

Connecting cables to the wrong post could damage the electrical system and result in personal injury.

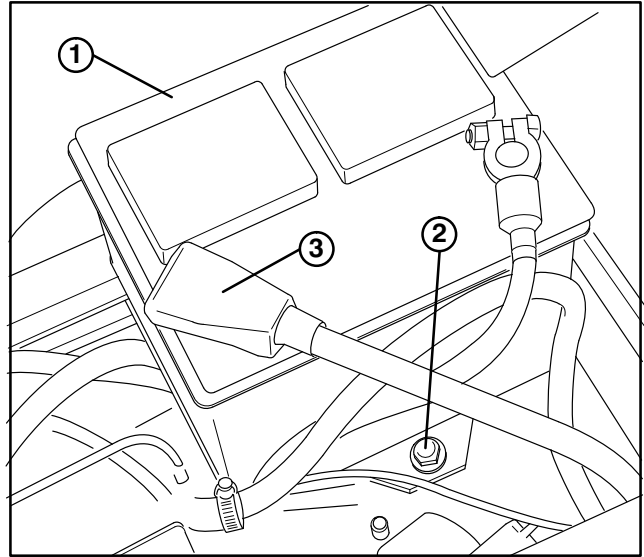

**Figure 11**

1. Battery
2. Battery securing bolt (2)
3. Rubber boot

**Note:** Make sure battery cables are routed away from any sharp edges or moving parts.

4. Coat the terminal with sealant such as Grafo 112X, Toro Part No. 505-47 and install the rubber boot onto positive terminal.

## CHECK TIRE PRESSURE

The tires are over-inflated for shipping. Therefore, release some of the air to reduce the pressure. Correct air pressure in front and rear tires is 20 psi.

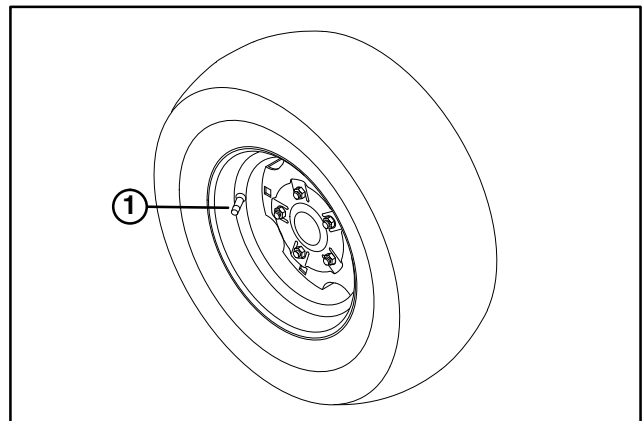

**Figure 12**

1. Front tire valve stem

# BEFORE OPERATING

## CHECK ENGINE OIL

The engine is shipped with 3.8 qt (3.6 l) of oil in the crankcase; however, level of oil must be checked before and after the engine is first started.

1. Position machine on a level surface.
2. Open the hood.
3. Remove dipstick and wipe it with a clean rag. Insert dipstick into the tube and make sure it is seated fully. Remove dipstick and check level of oil (Fig. 13). If oil level is low, add enough oil to raise level to FULL mark on dipstick. Do not overfill (Fig. 14).

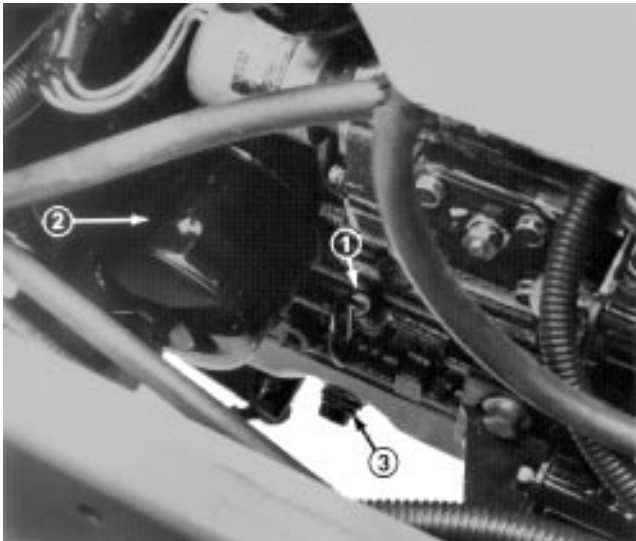

Figure 13

1. Engine oil dipstick
2. Engine oil filter
3. Oil drain plug

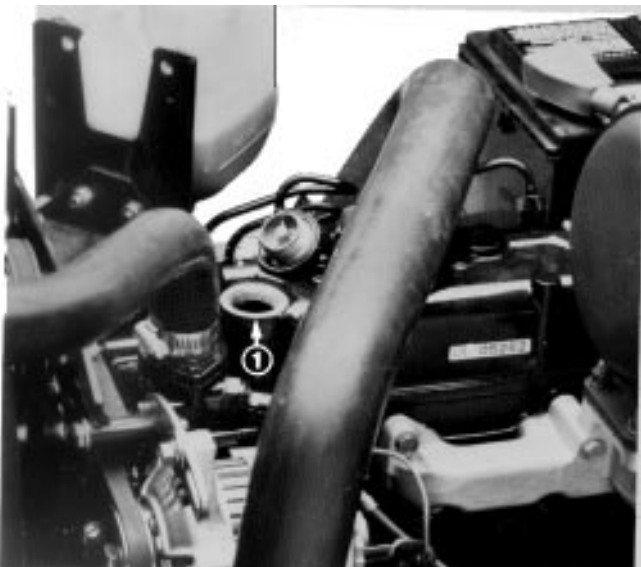

Figure 14

1. Engine oil fill

**Note:** If level of oil is at the ADD mark on the dipstick, add 1 pint (0.47 l) of oil and recheck level. Do not overfill.

4. The engine uses any high-quality 10W30 detergent oil having the American Petroleum Institute — API — “service classification” CD.

**IMPORTANT:** Check level of oil every 5 operating hours or daily. Change oil after every 50 hours of operation.

5. Insert dipstick into tube.

## CHECK COOLING SYSTEM

Clean debris off screen and front of radiator daily (Fig. 15), hourly if conditions are extremely dusty and dirty; refer to Cleaning Radiator and Screen Section.

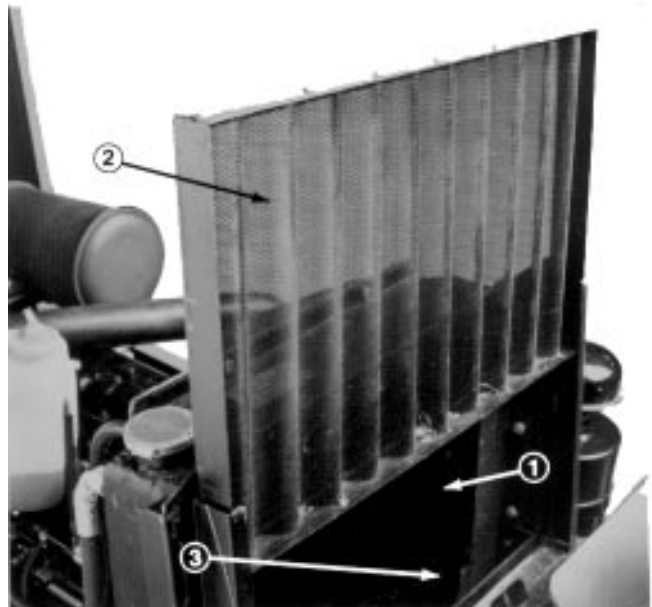

Figure 15

1. Radiator
2. Radiator screen
3. Screen channel

The cooling system is filled with a 50/50 solution of water and permanent ethylene glycol anti-freeze. Check level of coolant at beginning of each day (Fig. 16) before starting the engine. Capacity of cooling system is approximately 6 quarts (5.7 l).

1. Carefully remove radiator cap and the expansion tank cap.



## CAUTION

If engine has been running, pressurized hot coolant can escape when radiator cap is removed and cause burns.

# BEFORE OPERATING

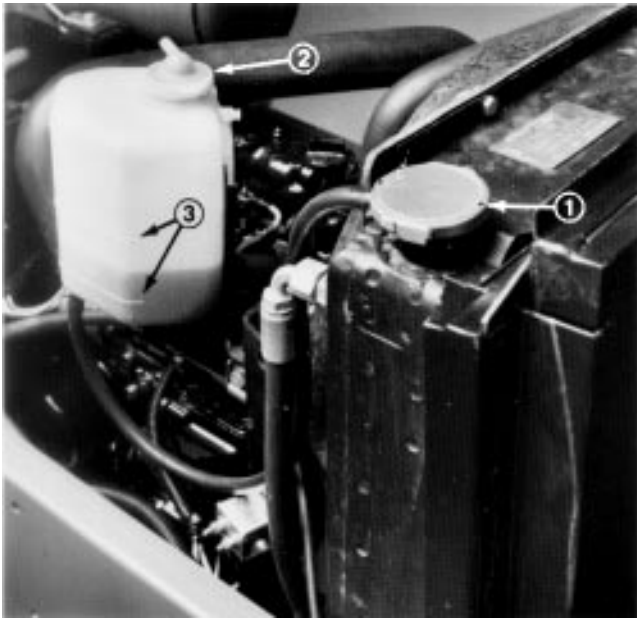

**Figure 16**

1. Radiator cap
2. Expansion tank cap
3. Expansion tank fill marks

2. Check level of coolant in radiator. Radiator should be filled to the top of the filler neck and the expansion tank filled to between the marks on its side.
3. If coolant level is low, replenish the system. **DO NOT OVERFILL.**
4. Install radiator cap and expansion tank cap.

## CHECK HYDRAULIC SYSTEM FLUID

The hydraulic system was designed to operate on any high quality detergent oil having the American Petroleum Institute—API—“service classification” SF, CC or CD. Oil viscosity — weight — must be selected according to anticipated ambient temperature. Temperature/viscosity recommendations are:

Expected Ambient Temperature	Recommended Viscosity and Type
(Extreme) over 90° F	SAE 30, Type SF, CC or CD engine oil.
(Normal) 40-100° F	SAE 10W-30 or 10W-40. Type SF, CC or CD engine oil.
(Cool—Spring/Fall) 30–50° F	SAE 5W-30, Type SF, CC or CD engine oil.
(Winter) Below 30° F	Type “F” or “FA” ATF Automatic Transmission Fluid.

**Note:** Do not mix engine oil and automatic transmission fluid or hydraulic component damage may result. When changing fluids, also change transmission filter. **DO NOT USE DEXRON II ATF.**

The axle housing acts as the reservoir for the system. The transmission and axle housing are shipped from the factory with approximately 5 quarts (4.7 l) of SAE 10W-30 engine oil. However, check level of transmission oil before engine is first started and daily thereafter.

1. Position machine on a level surface. Place all control in neutral position and start the engine. Run engine at lowest possible RPM to purge the system of air. **DO NOT ENGAGE PTO.** Cycle steering wheel several times fully to the left and right. Raise the cutting unit to extend lift cylinders, aiming steering wheels straight forward and stop the engine.

2. Remove dipstick cap (Fig. 17) from filler neck and wipe it with a clean rag. Screw dipstick cap finger-tight onto filler neck; then remove it and check level of fluid. If level is not within 1/2 inch (13 mm) from the groove in the dipstick (Fig. 17), add SAE 10W-30 engine oil, or, if used, automatic transmission fluid to raise level to groove mark. Do not overfill.

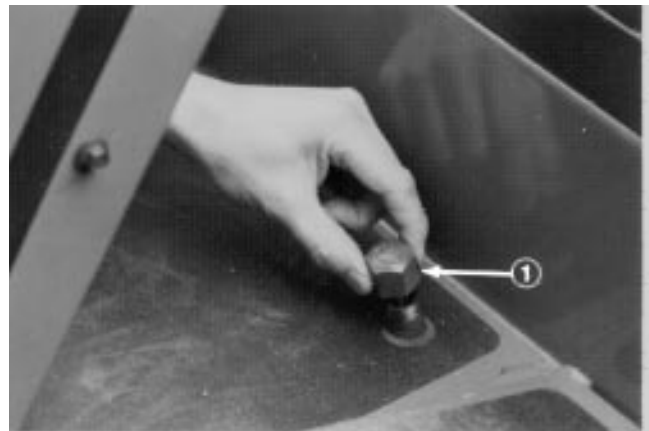

**Figure 17**

1. Hydraulic system reservoir fluid/add dipstick cap

**IMPORTANT: When adding transmission fluid to the hydraulic system, use a funnel with a fine wire screen — 200 mesh or finer — and make sure funnel and transmission fluid are immaculately clean. This procedure prevents accidental contamination of the hydraulic system.**

3. Thread dipstick fill cap finger-tight onto filler neck. It is not necessary to tighten cap with a wrench.
4. Check all hoses and fittings for leaks.

# BEFORE OPERATING

## FILL FUEL TANK



### DANGER

Because diesel fuel is flammable, caution must be used when storing or handling it. Do not fill fuel tank while engine is running, hot, or when machine is in an enclosed area. Vapors may build up and be ignited by a spark or flame source many feet away. DO NOT SMOKE while filling the fuel tank to prevent the possibility of an explosion. Always fill fuel tank outside and wipe up any spilled diesel fuel before starting engine. Use a funnel or spout to prevent spilling diesel fuel and fill tank to about 1 inch (25 mm) below the filler neck. Store diesel fuel in a clean, safety-approved container and keep the cap in place on the container. Keep diesel fuel in a cool, well-ventilated place; never in an enclosed area such as a hot storage shed. To assure volatility and to prevent contamination, do not buy more than a 6 month supply.

The engine runs on No. 2-D or 1-D automotive type diesel fuel with a minimum cetane rating of 40.

**Note;** Higher cetane rated fuel may be required if machine is to be used at high altitudes and low-atmospheric temperatures.

Use No. 2-D diesel fuel at temperatures above 20° F (-7° C) and No. 1-D diesel fuel below 20° F (-7° C). Use of No. 1-D diesel fuel at lower temperatures provides lower flash point and pour point characteristics, therefore easing startability and lessening chances of chemical separation of the fuel due to low temperatures (wax appearance, which may plug filters).

Use of No. 2-D diesel fuel above 20° F (-7° C) will contribute toward longer life of the pump components. Do not use furnace oil. Furnace oils usually contain heavy cracked distillates which are not suitable for diesel engines.

Store fuel outside of buildings in a convenient location. Tipping the front of the tank up slightly will allow contaminants to collect at the lower end away from the outlet. Never empty the tank below 4 in. (10 cm) from the bottom of the tank to avoid picking up water and other contaminants that may have collected at the bottom. Either filter the remainder at the bottom through a chamois or dispose of it periodically to prevent excessive build-up of contaminants.

Keep all fuel containers free of dirt, water, scale and other contaminants. Many engine difficulties can be traced to contaminants in the fuel.

Use only metal containers for fuel storage. DO NOT store the fuel in a galvanized metal container. A chemical reaction will result, which will plug the filters and cause possible fuel system damage.

If possible, fill the fuel tank at the end of each day. This will prevent possible buildup of condensation inside the fuel tank, preventing possible engine damage. Allow the engine to thoroughly cool down before refueling.

1. Using a clean rag, clean area around fuel tank cap.
2. Remove cap from the fuel tank (Fig. 18) and fill the 8 gallon (34 l) tank to within 1 inch (25 mm) from the top with diesel fuel. Install fuel tank cap tightly after filling tank.



**Figure 18**

1. Fuel tank cap

## CHECK REAR AXLE LUBRICANT

The rear axle has three separate reservoirs which use SAE 80W-90 wt. gear lube. Although the axle is shipped with lubricant from the factory, check the level before operating the machine.

1. Position the machine on a level surface.
2. Remove a check plug from each end of axle and make sure lubricant is up to bottom of hole. If level is low, remove one of the mounting bolts above each end plug and add enough lubricant to bring the level up to the bottom of the hole (Fig. 19).

## BEFORE OPERATING



Figure 19

1. Check Plugs (2)
2. Mounting Bolts

3. Remove plug in center of axle and check level. If level is low, add enough lubricant to bring the level up to the bottom of the hole.

4. To make sure that the cavities at each end of axle tube are filled, jack up each side of the axle approximately 6". Then with axle level, check level at center plug hole.

## CONTROLS

**Service Brakes** (Fig. 20) — The left and right brake pedals are connected to the left and right front wheels. Since both brakes work independently of each other, the brakes can be used to turn sharply or to increase traction if one wheel tends to slip while operating on certain slope conditions. However, wet grass or soft turf could be damaged when brakes are used to turn sharply. To make a “quick-stop”, depress both brake pedals together. Always lock brakes together when transporting the traction unit.



Figure 20

1. Parking brake knob
2. Right brake pedal
3. Left brake pedal

**Parking Brake** — Whenever the engine is shut off, the parking brake must be engaged to prevent accidental movement of the machine. To engage the parking brake, push lock arm (Fig. 21) on left brake pedal so that it locks together with the right pedal. Next, push down fully on both pedals and pull parking brake knob out (Fig. 20) then release the pedals. To release parking brake, depress both pedals until parking brake knob retracts. Before starting the engine, however, lock arm may be disengaged from left brake pedal so both pedals work independently with each front wheel.

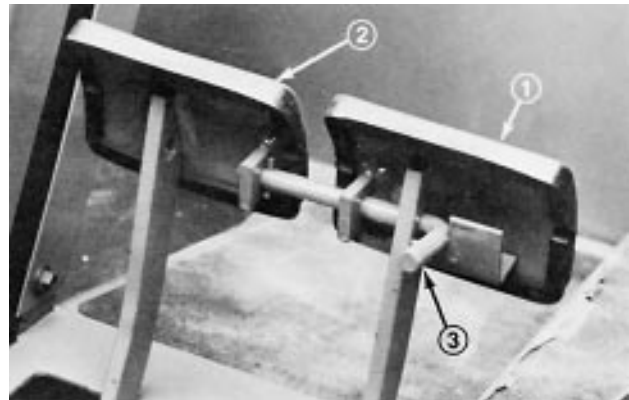

Figure 21

1. Left brake pedal
2. Right brake pedal
3. Lock arm

# CONTROLS

**Amp Light** (Fig. 22) — The amp light should be off when engine is running. If it is on, the charging system should be checked and repaired if necessary.



**Figure 22**

- |                                   |                          |
|-----------------------------------|--------------------------|
| 1. Amp light                      | 7. PTO switch            |
| 2. Hour meter                     | 8. Glow plug indicator   |
| 3. Coolant temperature gauge      | 9. Glow plug switch      |
| 4. High temperature shutoff light | 10. Throttle             |
| 5. Ignition key switch            | 11. Hydraulic lift lever |
| 6. Oil pressure light             | 12. Fuel gauge           |

**Hour Meter** (Fig. 22) — Accumulated engine operating time registers on the hour meter.

**Temperature Gauge and High Temperature Light** (Fig. 22) — The coolant temperature gauge registers the coolant temperature in the system. If the temperature gets too high the engine will automatically shut off and the High Temperature Shutoff Light will light. When this happens, turn the ignition key off, check radiator for debris, check the fan belt and check the expansion tank for proper coolant level. The high temperature shutoff will automatically reset when the coolant temperature has reached a safe level.

**Low Oil Pressure Light** (Fig. 22) — If engine oil pressure falls below a safe level, the light glows. Stop engine and repair before resuming operation.

**PTO Switch** (Fig. 22) — Pull up on sleeve on toggle switch handle and move handle to ON to ENGAGE electric PTO clutch. Pull up on sleeve and move handle to OFF to DISENGAGE electric PTO clutch. The only time the PTO switch should be in the ENGAGE position is when the implement is down in operating position and ready to begin operation.

**Ignition Key Switch** (Fig. 22) — The ignition switch, which is used to start and stop the engine, has three

positions: OFF, RUN and START. Rotate key clockwise — START position — to engage starter motor. Release key when engine starts. The key will move automatically to the ON position. To shut engine off, rotate key counterclockwise to the OFF position.

**Glow Plug Switch and Indicator** (Fig. 22) — Use to preheat engine cylinders prior to cold engine starting procedures — cylinders are preheated automatically during warm engine start operation. For cold starting, push switch lever upward and hold while watching indicator. Indicator will glow orange when the glow plugs are activated. Length of time necessary to preheat cylinders should be determined by atmospheric temperature; refer to Starting /Stopping Engine procedure.

**Throttle** (Fig. 22) — Throttle is used to operate engine at various speeds. Moving throttle forward increases engine speed — FAST; rearward decreases engine speed — SLOW. The throttle controls the speed of the cutter blades and, in conjunction with traction pedal, controls ground speed of the traction unit.

**Hydraulic Lift Lever** (Fig. 22) — The hydraulic lift lever has three positions: FLOAT, TRANSPORT and RAISE. To lower cutting unit to the ground, move lift lever forward into notch in seat platform — FLOAT. The FLOAT position is used for mowing and when machine is not in operation. To raise cutting unit, pull lift lever rearward to the RAISE position. After cutting unit is raised, allow lift lever to move to the TRANSPORT position. Cutting unit must be raised when driving from one work area to another.



## CAUTION

**Never raise cutting unit while blades are rotating because it is hazardous.**

**Traction Pedal** (Fig. 23) — Traction pedal has two functions: one is to make the machine move forward, the other is to make it move rearward. Using the heel and toe of the right foot, depress top of pedal to move forward and bottom of pedal to move rearward. Ground speed is proportionate to how far pedal is depressed. For maximum ground speed, traction pedal must be fully depressed while throttle is in FAST position. Maximum speed forward is 10 mph (16 Km/hr) (approx.). To get maximum power under heavy load or when ascending a hill, have throttle in FAST position while depressing traction pedal slightly to keep engine rpm high. When engine rpm begins to decrease, release traction pedal slightly to allow rpm to increase.

# CONTROLS

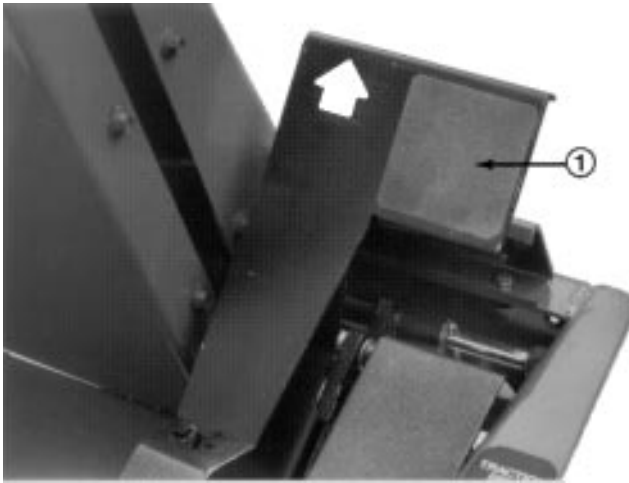

Figure 23

1. Traction pedal

**Seat Adjusting Handle** — To adjust seat, loosen adjusting knobs and slide seat to desired position. Tighten knobs to lock seat in place.

**Seat Adjusting Handle — Deluxe Seat** — To adjust seat, move lever on left side outward, slide seat to desired position and release lever so it will lock in track.

## OPERATING INSTRUCTIONS

### STARTING/STOPPING ENGINE

**IMPORTANT:** The fuel system must be bled if any of the following situations have occurred.

- A. Initial start up of a new machine.
- B. Engine has ceased running due to lack of fuel.
- C. Maintenance has been performed upon fuel system components; i.e., filter replaced, separator serviced, etc.

#### Refer to Bleeding The Fuel System.

1. Ensure parking brake is set, PTO switch is in OFF position and lift lever is in TRANSPORT or FLOAT position (Fig. 22). Remove foot from traction pedal and insure it is in neutral.
2. Move throttle control (Fig. 22) to full FAST position.
3. When temperature is below 15°C (60°F), push glow plug switch to ON position (Fig. 22) and hold for suggested interval.

**Note:** Do not exceed 1 minute of continuous use or glow plug may burn out prematurely.

**Note:** Refer to chart indicating approximate preheat time suggested in various temperature ranges.

Temperature	Preheat time (sec)
Above 5°C (41°F)	10
+5°C (41°F) to -5°C (23°F)	20
Below -5°C (23°F)	30

4. Turn key in ignition switch to START position (Fig. 22). Release key immediately when engine starts and allow it to return to RUN position. Move throttle control to SLOW position.

**Note:** Do not run starter motor more than 20 seconds at a time or premature starter failure may result. If engine fails to start after 20 seconds, turn key to OFF position, recheck controls and procedures, wait 10 additional seconds and repeat starter operation.

5. When engine is started for the first time, or after engine oil change, or overhaul of engine, transmission or axle, operate the machine in forward and reverse for one to two minutes. Also operate the lift lever and PTO lever to assure proper operation of all parts. Turn power steering wheel to the left and right to check steering response. Then shut engine off and check fluid levels, check for oil leaks, loose parts and any other noticeable malfunctions.



### CAUTION

**Shut engine off and wait for all moving parts to stop before checking for oil leaks, loose parts or other malfunctions.**

6. To stop engine, move throttle control backward to SLOW position, move PTO switch to OFF position and rotate ignition key to OFF. Remove key from switch to prevent accidental starting.

### BLEEDING FUEL SYSTEM

1. Raise hood over engine.
2. Loosen air bleed screw on top of fuel filter/water separator (Fig. 24).

# OPERATING INSTRUCTIONS

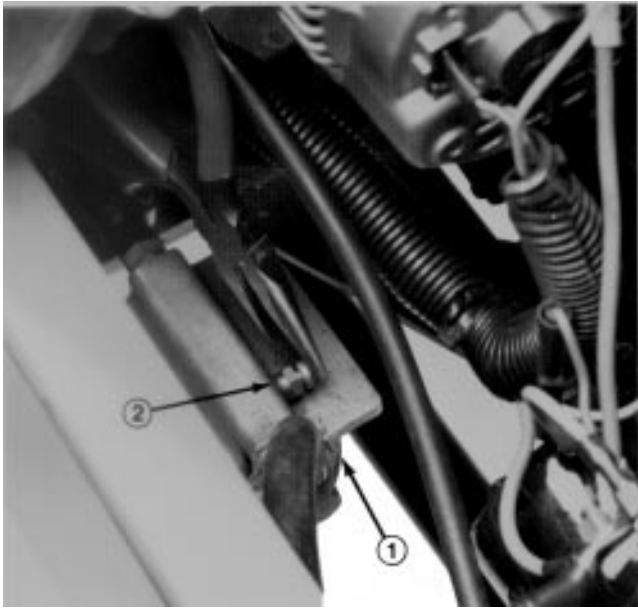

**Figure 24**

1. Fuel filter      2. Air bleeder screw

3. Turn key in ignition switch to the RUN position. Electric fuel pump will begin operation, thereby forcing air out around air bleed screw. Leave key in RUN position until solid stream of fuel flows out around screw. Tighten screw and turn key to OFF.

4. Open the air bleed screw on the fuel injection pump (Fig. 25) with a 10 mm wrench.



**Figure 25**

1. Fuel injection pump bleeder

5. Turn key in ignition switch to the RUN position. Electric fuel pump will begin operation, thereby forcing air out around air bleed screw on fuel injection pump. Leave key in RUN position until solid stream of fuel flows out around the screw. Tighten screw and turn key to OFF.

**Note:** Normally, engine should start after above bleeding procedures are followed. However, if engine does not start, air may be trapped between injection pump and injectors; refer to Bleeding Air From Injectors.

## CHECKING INTERLOCK SYSTEM

The purpose of the safety interlock system is to prevent the engine from cranking or starting unless the traction pedal is in neutral and the PTO switch is in the OFF position. In addition, the engine will stop when the PTO control is engaged or traction pedal is depressed with operator off the seat.



### CAUTION

**Do not disconnect the safety switches because they are for the operator's protection. Check operation of the switches daily to be sure the interlock system is operating correctly. If a switch is malfunctioning, replace it before operating the machine. Replace the switches every 2 years to be sure of maximum safety.**

1. Move PTO switch to OFF position and remove foot from traction pedal so it is fully released.

2. Rotate the ignition key to START. Engine should crank. If engine cranks, proceed to step 3. If engine does not crank, there may be a malfunction in the interlock system.

3. Raise off the seat and engage the PTO switch while the engine is running. The engine should stop within 2 seconds. If engine stops, the switch is operating correctly; thus, proceed to step 4. If engine does not stop, there is a malfunction in the interlock system.

4. Raise off the seat and depress the traction pedal while engine is running the PTO lever is disengaged. The engine should stop within 2 seconds. If engine stops, the switch is operating correctly; thus, continue operation. If engine does not stop, there is a malfunction in the interlock system.

## OPERATING CHARACTERISTICS

Practice driving the GROUNDMASTER® 223-D 4 Wheel Drive before initial operation because it has a hydrostatic transmission and its characteristics are different than some turf maintenance machines. Some points to consider when operating the traction unit and cutting unit are the transmission, engine speed, load on the cutting blades, and the importance of the brakes.

# OPERATING INSTRUCTIONS



## CAUTION

**Adequate rear weight is necessary to prevent the rear wheels from leaving the ground. Do not stop suddenly while cutting unit or implement is raised. Do not travel down hill with the cutting unit or implement raised. If the rear wheels leave the ground, steering is lost.**

To maintain enough power for the traction unit and cutting unit while mowing, regulate traction pedal to keep engine rpm high and somewhat constant. A good rule to follow is: decrease ground speed as the load on the cutting blades increases; and increase ground speed as load on the blades decreases. This allows the engine, working with the transmission, to sense the proper ground speed while maintaining high blade tip speed necessary for good quality-of-cut. Therefore, allow traction pedal to move upward as engine speed decreases, and depress pedal slowly as speed increases. By comparison, when driving from one work area to another—with no load and cutting unit raised—have throttle in FAST position and depress traction pedal slowly but fully to attain maximum ground speed.

**CAUTION:** This product may exceed noise levels of 85 dB(A) at the operator position. Ear protectors are recommended for prolonged exposure to reduce the potential of permanent hearing damage.

Another characteristic to consider is the operation of the brakes. The brakes can be used to assist in turning the machine; however, use them carefully, especially on soft or wet grass because the turf may be torn accidentally. The brakes can be used to great advantage to control the direction of the cutting unit when trimming along fences or similar objects. The other benefit of the brakes is to maintain traction. For example; in some slope conditions, the uphill wheel slips and loses traction. If this situation occurs, depress uphill brake pedal gradually and intermittently until the uphill wheel stops slipping; thus, increasing traction on the downhill wheel. If independent braking is not desired, engage the lever on left brake pedal with right pedal. This provides simultaneous braking at both wheels.

Before stopping the engine, disengage all control and move throttle to SLOW. Moving throttle to SLOW reduces high engine speed, noise and vibration. Turn ignition key to OFF to stop the engine.

## PUSHING OR TOWING TRACTION UNIT

In an emergency, the traction unit can be pushed or towed for a very short distance. However, Toro does not recommend this as standard procedure.

**IMPORTANT: Do not push or tow the traction unit faster than 2 to 3 mph (3.2 to 4.8 Km/hr) because transmission may be damaged. IF traction unit must be moved a considerable distance, transport it on a truck or trailer. Whenever traction unit is pushed or towed, by-pass valve must be open.**

1. Remove hair pin, pivot seat platform forward and locate seat support rod in detent notch.
2. Depress and hold the pins located in the center of the two (2) check valve assemblies in the top of the transmission (Fig. 26) while pushing or towing the machine.

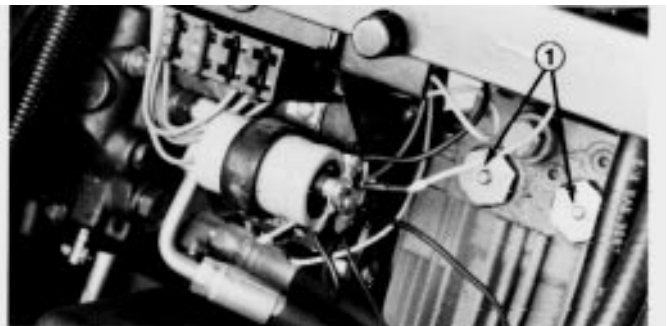

**Figure 26**

1. Transmission check valve bypass pins (2)

3. Start engine momentarily after repairs are completed and make sure the pins are in the full disengaged (fully up) position.

**IMPORTANT: Running the machine with by-pass valve open will cause the transmission to overheat.**

# DAILY MAINTENANCE CHECKLIST

**Daily Maintenance:** (duplicate this page for routine use)

Maintenance Check Item ➔	Daily Maintenance Check For Week Of _____						
	MON	TUES	WED	THURS	FRI	SAT	SUN
✓ Safety Interlock Operation							
✓ Grass Deflector in Down Position							
✓ Brake Operation							
✓ Fuel Level							
✓ Engine Oil Level							
✓ Cooling System Fluid Level							
✓ Drain Water/Fuel Separator							
✓ Dust Cup and Baffle (Air Filter)							
✓ Radiator & Screen for Debris							
✓ Unusual Engine Noises <sup>1</sup>							
✓ Transmission Oil Level							
✓ Hydraulic Hoses for Damage							
✓ Fluid Leaks							
✓ Tire Pressure							
✓ Instrument Operation							
✓ Condition of Blades							
Lubricate All Grease Fittings <sup>2</sup>							
Touch-up Damaged Paint							

<sup>1</sup> = Check glow plug and injector nozzles, if hard starting, excess smoke or rough running is noted.

<sup>2</sup> = Immediately after every washing, regardless of the interval listed.

**Notation for areas of concern:**      Inspection performed by \_\_\_\_\_

Item	Date	Information
1		
2		
3		
4		
5		
6		
7		
8		

Check proper section of Operator's Manual for fluid specifications

# LUBRICATION

## GREASING BEARINGS AND BUSHINGS

The traction unit has grease fittings that must be lubricated regularly with No. 2 General Purpose Lithium Base Grease. If machine is operated under normal conditions, lubricate all bearings and bushings after every 50 hours of operation. Bearings and bushings must be lubricated daily when operating conditions are extremely dusty and dirty. Dusty and dirty operating conditions could cause dirt to get into the bearings and bushings, resulting in accelerated wear. Lubricate grease fittings immediately after every washing, regardless of the interval listed.

Apply a liberal coating of grease to the check valve pins once each year (Fig. 26). The traction unit has bearings and bushings that must be lubricated, and these lubrication points are: PTO universal shaft (Fig. 27); lift arm pivot bushings (Fig. 28); front PTO bearing (Fig. 28); brake pivot bushings (Fig. 29); clutch housing and drive shaft (Fig. 30); tie rod and cylinder rod ends (Fig. 31); PTO tension pivot (Fig. 32) rear PTO bearing (Fig. 32). Also apply grease to both brake cables at the drive wheel and brake pedal ends (Fig. 29).

1. Wipe grease fitting clean so foreign matter cannot be forced into the bearing or bushing.
2. Pump grease into the bearing or bushing.
3. Wipe up excess grease.

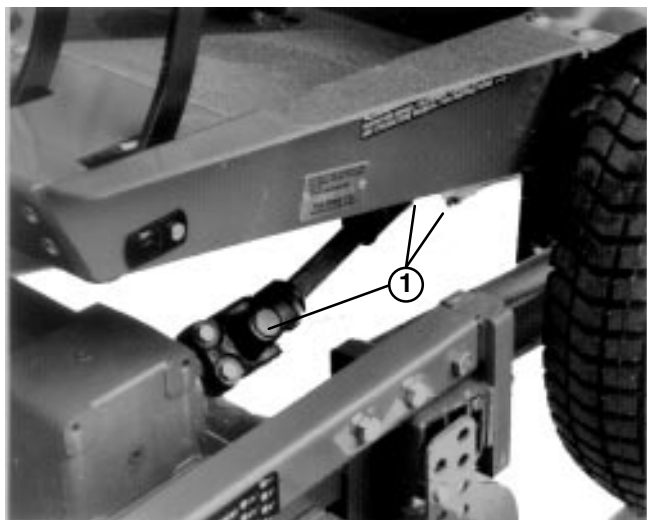

**Figure 27**

1. PTO shaft lubrication: 3 places on shaft

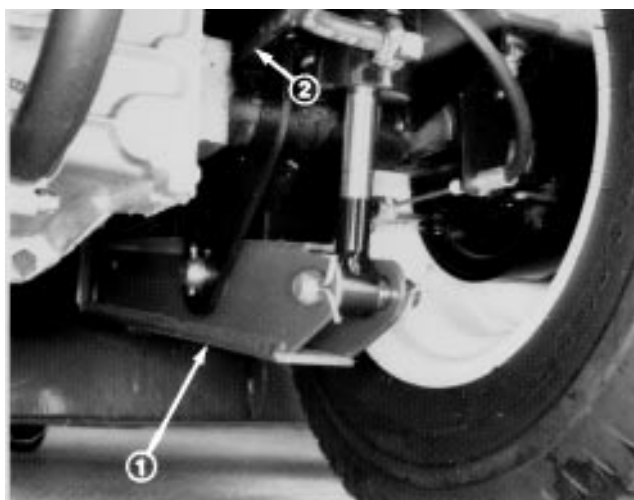

**Figure 28**

1. Lift arm pivot bushings on each side
2. Front PTO bearing

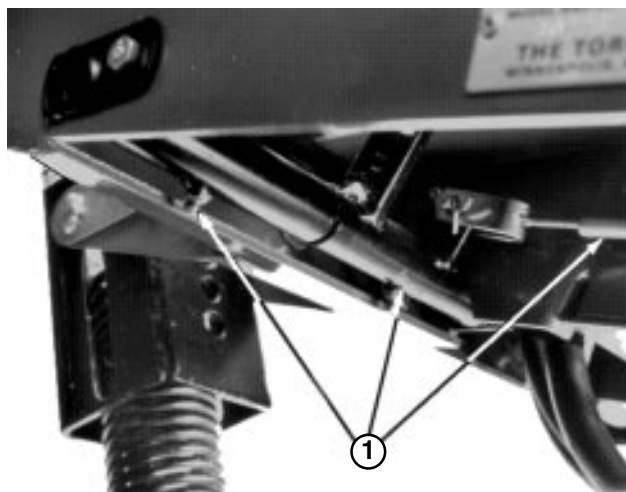

**Figure 29**

1. Apply grease to both ends of both brake cables and brake pivot tubes.

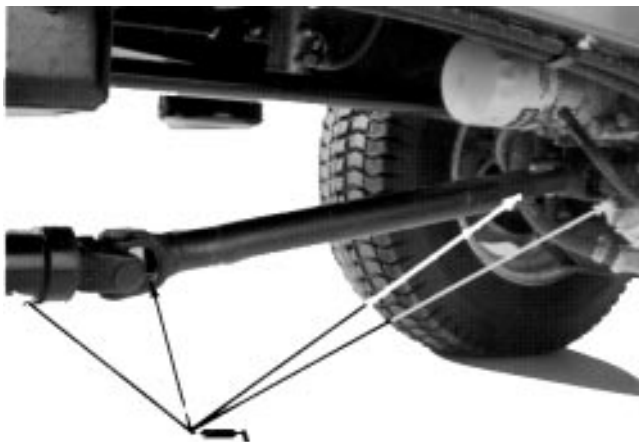

**Figure 30**

1. Clutch housing and drive shaft

# LUBRICATION



Figure 31

1. Tie rod ends, cylinder rod & pivot pin

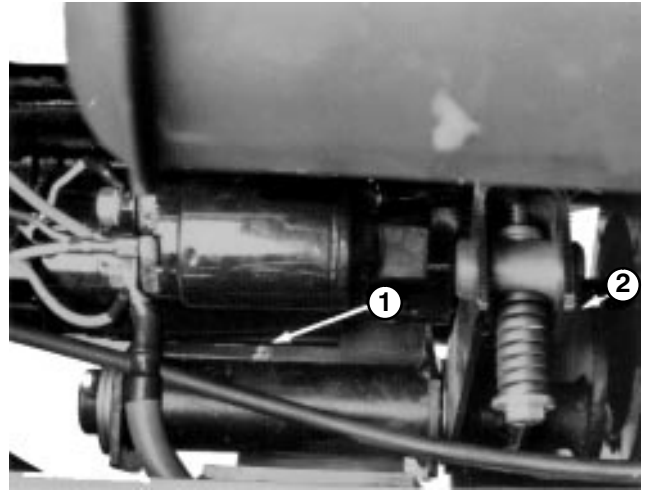

Figure 32

1. Grease PTO tension pivot
2. Rear PTO bearing

# SERVICE INTERVAL CHART

**CHECK/SERVICE**

1. Oil levels (Engine/Trans.)
2. Coolant level
3. Tire pressure
4. Belts (Fan, Alt, PTO)
5. Fuel - Diesel Only
6. Battery
7. Grease. Lube points
8. Radiator screen
9. Air cleaner
10. Electric clutch gap .015-.030
11. PTO Belt tension
12. Water separator

**FILTERS**      **PART NO.**

A. Air            27-7110

B. Fuel Pump    43-2550

C. Fuel line      63-8300

D. Trans. Oil     23-2300

E. Engine Oil    67-4330

## GM 223-D QUICK REFERENCE AID

**FLUID SPECIFICATIONS \*See operator's manual for initial changes.**

	TYPE >32° F 0°C	TYPE <32° F 0°C	CAPACITY	*CHANGE INTERVALS	
Engine oil	SAE 30 CD	SAE 10W-30 CD	3.9 QT. <small>W. FILTER</small>	50 hrs.	filter 100hrs.
Trans oil	SAE 10W-30 SF,CC,CD	TYPE For FA Trans. Fluid	6 QT.	200 hrs.	filter 200hrs.
Fuel	NO. 2 - D	NO. 1 - D	8.5 GAL.	—	filter 400hrs.
Coolant	50/50 MIX Ethylene glycol anti-freeze/Water		7 QT.	2 years	

84-1960

# MAINTENANCE

## GENERAL AIR CLEANER MAINTENANCE

To prevent possible severe engine damage and ensure maximum engine service life, periodically inspect the air cleaner and hose assembly.

1. Assure hose between air cleaner and carburetor is clamped securely in place. Replace the hose if it is cracked or punctured.
2. Check air cleaner body for dent and other damage which could possibly cause an air leak. Replace a damaged air cleaner body.
3. Insure dust cap is sealing around bottom of air cleaner body.
4. Mounting screws and nuts holding air cleaner in place must be tight.
5. Inlet cap must be free of obstructions.

2. Remove wing nut w/gasket and slide filter element out of air cleaner body (Fig. 33).

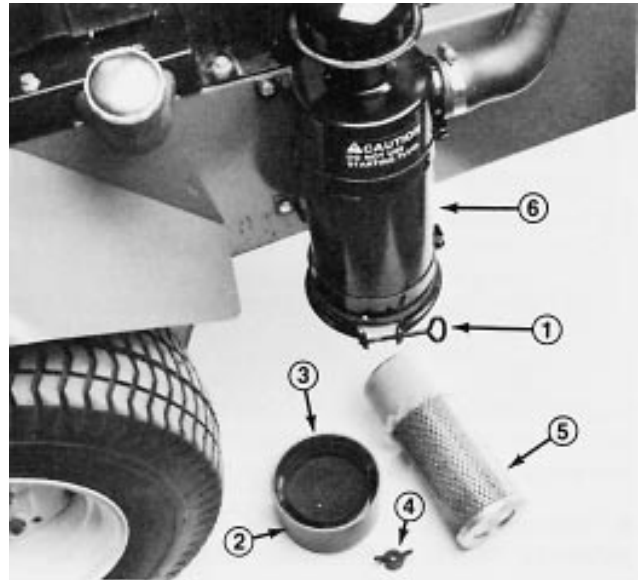

Figure 33

- |                |                         |
|----------------|-------------------------|
| 1. Thumb screw | 4. Wing nut with gasket |
| 2. Dust cup    | 5. Filter element       |
| 3. Baffle      | 6. Air cleaner body     |

## SERVICING DUST CUP AND BAFFLE

Inspect the dust cup and rubber baffle once a week or every 50 hours operation; however, daily or more frequent inspection is required when operating conditions are extremely dusty and dirty. Never allow dust to build up closer than one inch (25 mm) from the rubber baffle.

**Note:** If conditions are extremely dusty and dirty, begin by checking dust cup and baffle after each day's operation to establish approximately how long an interval passes before dust cup should be emptied. Base further maintenance requirements on this figure. These conditions may be particularly prevalent if the rear discharge cutting unit is attached.

1. Loosen thumb screw until dust cup and baffle can be removed (Fig. 33). Separate dust cup and baffle (Fig. 33).
2. Dump dust out of the dust cup. After cleaning cup and baffle, assemble and reinstall both parts.

## SERVICING AIR CLEANER FILTER

Service the air cleaner filter every 200 hours or more frequently in extreme dusty or dirty conditions by washing or using compressed air. Replace the element after every six cleanings (1200 hours) or annually, whichever comes first.

1. Remove and service dust cup; refer to Servicing Dust Cup and Baffle.

3. Clean the element by washing it in a solution of filter cleaner (Toro Part No. 27-7220, available from Toro) and water, or blow dirt out of filter by using compressed air.

**Note:** Compressed air is recommended when element must be used immediately after servicing because a washed element must be dried before it is used. By comparison, washing the element cleans better than blowing dirt out with compressed air. Remember, though, filter must be washed when exhaust soot is lodged in the filter pores.

### Washing Method

**IMPORTANT: Do not remove plastic fin assembly because washing removes dust from beneath fins.**

- A. Prepare a solution of filter cleaner and water and soak filter element about 15 minutes. Refer to directions on filter cleaner carton for complete information.
- B. After soaking filter for 15 minutes, rinse it with clear water. Maximum water pressure must not exceed 40 psi (276 kPa) to prevent damage to the filter element.
- C. Dry filter element using warm, flowing air (160°F (71°C) max), or allow element to air-dry. Do not use compressed air or a light bulb to dry the filter element because damage could result.

# MAINTENANCE

## Compressed Air Method

**IMPORTANT: Do not remove plastic fin assembly because back-blowing with compressed air removes dust from beneath fins.**

- A. Blow compressed air from inside to the outside of dry filter element. Do not exceed 100 psi (689 kPa) to prevent damage to the element.
  - B. Keep air hose nozzle at least one inch (25 mm) from pleated paper, and move nozzle up and down while rotating the filter element. Inspect element when dust and dirt are removed; refer to Inspecting Filter Element.
4. Wipe inside of air cleaner body with a damp cloth to remove excess dust. Slide filter into air cleaner body and secure it in place with wing nut and gasket.
  5. Reinstall dust cup and baffle. Move thumb screw behind air cleaner body and tighten it securely.

## INSPECTING FILTER ELEMENT

1. Place bright light inside filter.
2. Rotate filter slowly while checking for cleanliness, ruptures, holes, and tears. Replace defective filter element.
3. Check fin assembly, gasket, and screen for damage. Replace filter if damage is evident.

## CLEANING RADIATOR AND SCREEN

To prevent the engine from overheating, the screen and front of the radiator must be kept clean. Normally, check the screen and front of radiator daily and, if necessary, clean any debris off these parts. However, it will be necessary to check and clean the screen and radiator frequently in extremely dusty and dirty conditions.

**Note:** If engine shuts off due to overheating, first check the radiator and screen for excessive buildup of debris.

To thoroughly clean the radiator:

1. Remove the screen.
2. Working from the fan side of the radiator, either spray the radiator with a water hose or blow with compressed air.
3. After the radiator is thoroughly cleaned, clean out debris that may have collected in the channel at the radiator base.
4. Clean and install the screen.

## CHANGING ENGINE OIL AND FILTER

Check oil level after each day's operation or each time machine is used. Change oil after every 50 hours of operation; change oil filter after first 50 hours and every 100 hours operation thereafter. If possible, run engine just before changing oil because warm oil flows better and carries more contaminants than cold oil.

1. Position machine on a level surface.
2. Open the hood. Set drain pan under the oil pan and in line with drain plug (Fig. 34).
3. Clean area around drain plug.

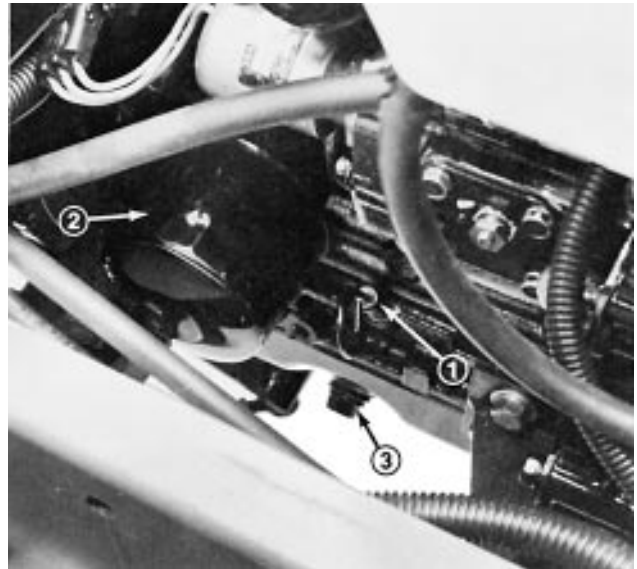

**Figure 34**

1. Engine oil dipstick
2. Engine oil filter
3. Oil drain plug

4. Remove oil drain plug and allow oil to flow into drain pan. Remove and replace oil filter (Fig. 34); refer to parts catalog for part number.
5. After oil is drained, reinstall drain plug and wipe up any oil that is spilled.
6. Fill crankcase with oil; refer to Check Crankcase Oil.

## SERVICING FUEL SYSTEM

**Note:** Refer to Fill Fuel Tank With Diesel Fuel for proper fuel recommendations.

### Fuel Tank

Drain and clean fuel tank every 400 hours operation or yearly, whichever comes first. Also, drain and clean tank if fuel system becomes contaminated or if machine is to be stored for an extended period. Use clean diesel fuel to flush out the tank.

# MAINTENANCE

## Fuel Lines and Connections

Check lines and connections daily for deterioration, damage or loose connections.

## Fuel Filter/Water Separator

Drain water or other contaminants from fuel filter/water separator daily (Fig. 35) by loosening drain plug on filter canister. Tighten plug after draining. Replace filter canister after every 400 hours of operation; refer to Specifications for Toro part number.

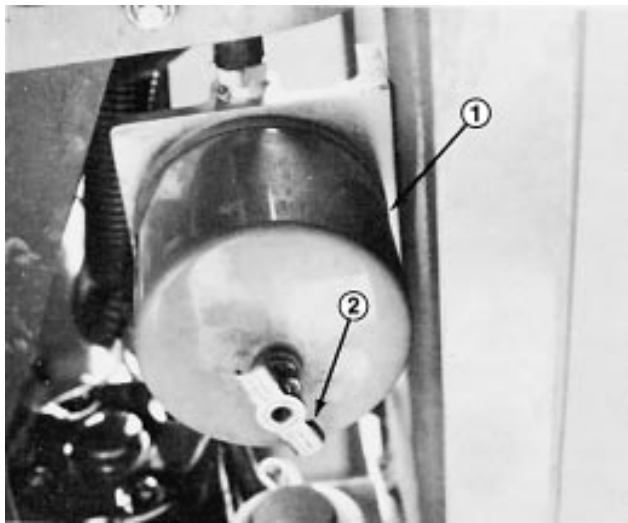

**Figure 35**

1. Fuel filter canister
2. Water drain

1. Clean area where filter canister mounts.
2. Remove filter canister and clean mounting surface.
3. Lubricate gasket on filter canister with 10W-40 SF-CC oil.
4. Install filter canister by hand until gasket contacts mounting surface, then rotate an additional 1/2 turn.

## Fuel Pump Filter

Remove and replace the filter after every 400 hours operation.

1. Fuel pump is located on inner frame on alternator side of engine (Fig. 36).
2. Thoroughly clean outside of assembly.

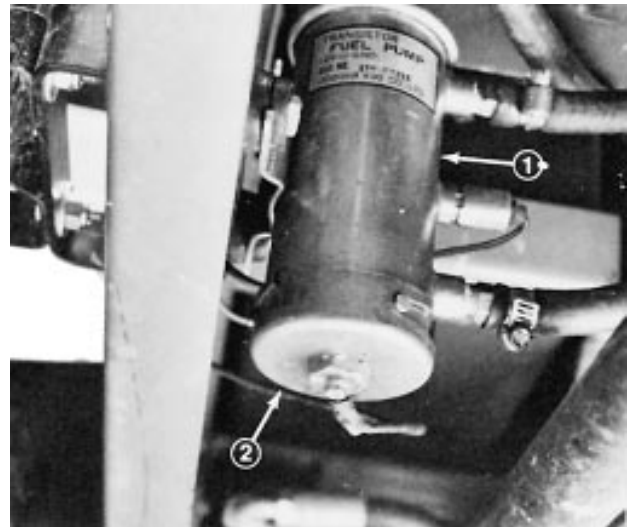

**Figure 36**

1. Fuel pump assembly
2. Fuel pump cover — unscrew

3. Place a drain pan under fuel pump and remove cover from fuel pump with 17 mm wrench (Fig. 37). Take care not to damage wire while removing cover.
4. Pull filter out of pump body (Fig. 37).



**Figure 37**

1. Filter
2. Magnet

5. If filter is to be cleaned, wash thoroughly in cleaning solvent and blow compressed air from inside toward outside of element. Hold air nozzle at least one inch (25 mm) from filter and move up and down while rotating filter. Do not exceed 100 psi (689 kPa) to avoid filter damage.

**Note:** Replace the filter if there is any visible dirt which cannot be washed out.

6. Inspect the two rubber gaskets; replace them if damaged.
7. Clean magnet of any residue (Fig. 37), insert filter into body and install cover.
8. Bleed the fuel system; refer to Bleeding Fuel System.

# MAINTENANCE

## BLEEDING AIR FROM INJECTORS

**Note:** This procedure should be used only if fuel system has been purged of air through normal priming procedures and engine still will not start; refer to Bleeding Fuel System.

1. Loosen the pipe connection to the No. 1 nozzle and holder assembly (Fig. 38).

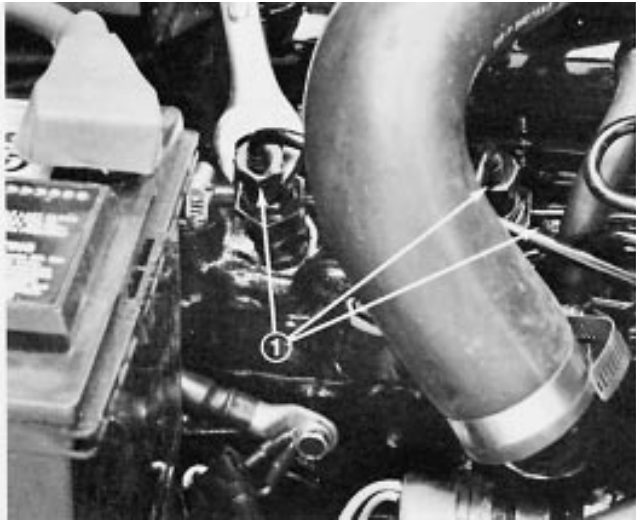

**Figure 38**

1. Fuel injectors (3)

2. Move throttle control to full FAST position.
3. Turn key in key switch to START position and watch fuel flow around connector. Turn key to OFF position when solid flow is observed.
4. Tighten pipe connector securely.
5. Repeat steps 1-4 on No. 2 and 3 nozzles.

## SERVICING ENGINE BELTS

Check tension of all belts initially after the first day of operation and every 100 hours thereafter.

### Alternator Belt

To Check Tension:

1. Open hood.
2. Check tension by depressing belt midway between alternator and crankshaft pulleys with 22 lb (10Kg) of force. Belt should deflect 7/16 in. (9 to 11 mm). If deflection is incorrect, proceed to step 3. If correct, continue operation.

3. Loosen bolt securing brace to engine and bolt securing alternator to brace (Fig. 39).

**Note:** Metric wrenches will be required.

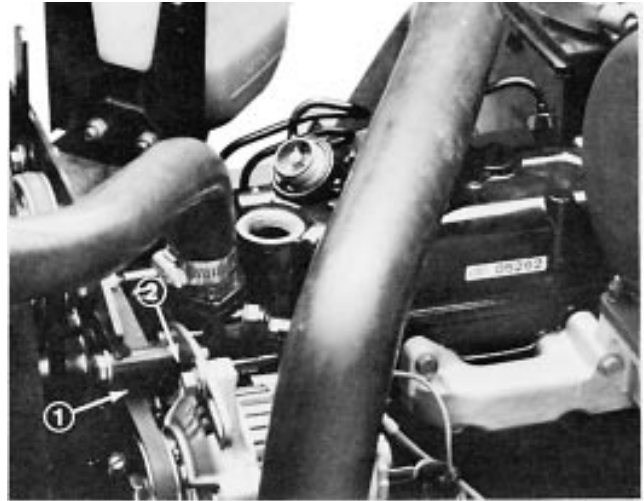

**Figure 39**

1. Alternator/water pump belt
2. Tension adjustment bolt

4. Insert pry bar between alternator and engine and pry out on alternator.
5. Hold alternator in position after proper belt tension setting is achieved and tighten alternator and brace bolts to secure adjustment.

To Replace Belt:

1. Open hood.
2. Loosen bolts securing brace to engine and alternator to brace (Fig. 39).
3. Remove two capscrews holding the transmission drive shaft coupler to the engine pulley (Fig. 40). Do not remove the drive shaft from the transmission.
4. Move the drive shaft out of the way so that the fan belt can be removed and a new belt installed. Install the new belt around the fan before positioning it around the drive pulley.
5. Reinstall the drive shaft. Tension the new belt. Close the hood.
6. Check the belt tension after one day's use.

### Cooling Fan Belt

To Check and Adjust Tension:

1. Open hood.
2. Loosen idler lever bolts (Fig. 40). Put 10 lb. of force on the top of idler lever and tighten the bolts.
3. Close hood.

# MAINTENANCE

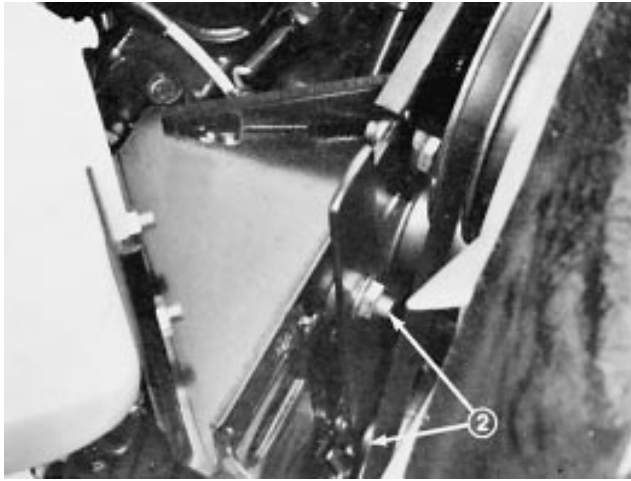

**Figure 40**

1. Fan belt      2. Belt tensoning bolts (2)

To replace belt:

1. Open hood. Loosen two flange nuts securing idler pulley lever and move pulley away from belt (Fig. 40).
2. Disconnect the transmission drive shaft assembly from the engine or crankshaft pulley.
3. Remove the belt form the top and bottom pulleys.
4. Install new belt and reconnect the transmission drive shaft assembly to the engine crankshaft pulley.
5. Adjust belt tension; refer to: To Check and Adjust Tension.
6. Close the hood.

**Note:** Check fan belt tension after first day of operation. Readjust tension, if necessary. Follow regular maintenance check procedures thereafter.

## PTO BELT

To Check Tension:

1. Turn engine off and remove the ignition key. Set the parking brake. Raise the engine hood and allow the engine to cool.
2. Loosen the tensoning rod jam nut (Fig. 41).
3. Use a 1/2" wrench to tighten or loosen the belt tensoning spring (Fig. 41). Adjust spring to a length of 1-1/2" (38 mm).
4. Tighten jam nut.

To Replace Belt:

1. Turn off the engine and remove the ignition key. Set the parking brake. Raise the hood and allow the engine to cool.
2. Loosen the tensoning rod jam nut (Fig. 41).
3. Using a 1/2" wrench, loosen the belt tensoning spring (Fig. 41) all the way.

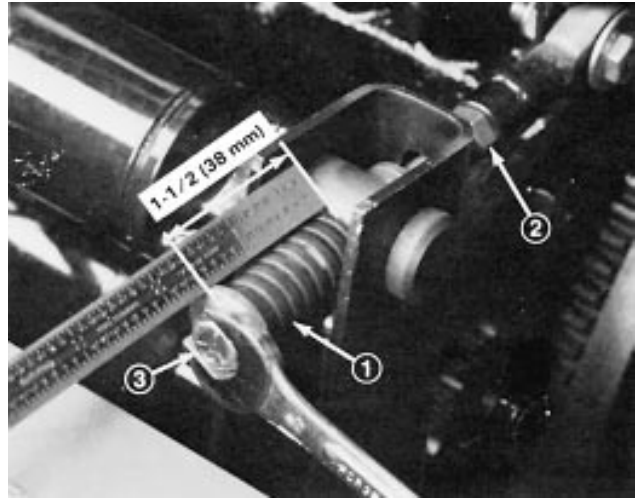

**Figure 41**

1. Tensioning spring      3. Tension adjusting bolt  
2. Tensioning rod jam nut

4. Rotate PTO pulley toward the engine and remove the belt (Fig. 42).
5. Install the new PTO belt and re-tension the pulley spring to 1-1/2" (38 mm) (Fig. 41).
6. Tighten the jam nut (Fig. 41) and close the hood.

## PTO CLUTCH ADJUSTMENT

The power take off electric clutch can be adjusted by following the following procedure:

1. Turn engine off and remove the ignition key. Set the parking brake. Raise the engine hood and allow the engine to cool.
2. Remove the left hand clutch retainer bracket nut and bolt so that the retainer bracket rubber bumper can be removed (Fig. 42).

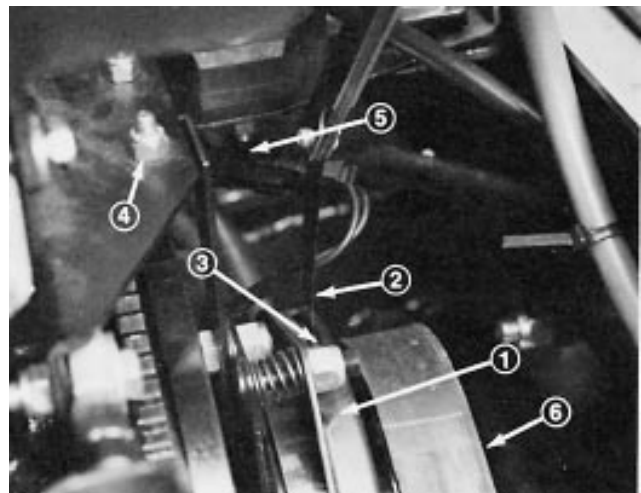

**Figure 42**

1. Clutch      4. Left retainer bracket nut & bolt  
2. .015" air gap (3)      5. Electrical connector  
3. Adjusting nut (3)      6. PTO belt
3. Unplug clutch electric connector (Fig. 42).

# MAINTENANCE

4. Adjust the air gap so that a .015 inch feeler gauge slides in between the clutch lining and friction plate with light pressure (Fig. 42). The gap can be decreased by turning the adjusting nut clockwise (Fig. 41).

5. Rotate the clutch by hand and adjust all three air gaps. After all three gaps have been set, check all three again. Adjusting one gap can alter the other gaps.

6. Reinstall the bracket and retaining nut and bolt. Reconnect the clutch electrical connector.

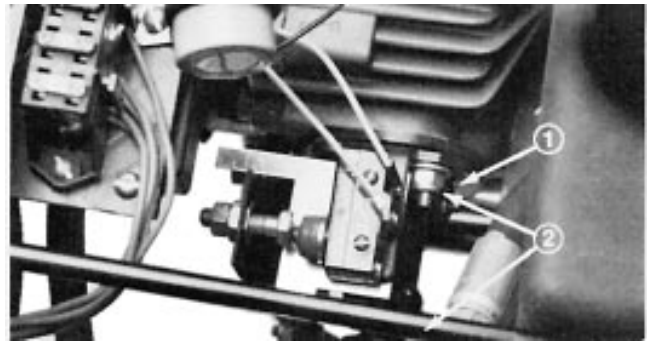

**Figure 43**

1. Pump plate                      2. Locknut

## CHANGING COOLANT IN COOLING SYSTEM

The cooling system must be filled with a 50/50 solution of water and permanent ethylene glycol anti-freeze. After every two years, drain the coolant from the radiator, reservoir expansion tank and engine by opening the drain cock and block plug. After coolant is drained, flush the entire system and refill it with a 50/50 solution of water and anti-freeze. Capacity of cooling system is approximately 7 quarts (6.4 l). When filling, fill the radiator completely and fill the expansion tank to between the marks. **DO NOT OVERFILL.** Always install radiator cap securely.

## ADJUSTING TRANSMISSION FOR NEUTRAL

The machine must not creep when traction pedal is released. If it does creep, an adjustment is required.

1. Park machine on a level surface and shut engine off. Depress only the right brake pedal and engage the parking brake.

2. Jack up left front side of machine until tire is off shop floor. Support machine with jack stands to prevent it from falling accidentally.

3. Lift seat. Visually inspect traction linkage for possible binding condition, correct if necessary and check machine operation. If condition still exists, repeat steps 1 and 2 and proceed to step 4.

4. Loosen two locknuts securing pump plate so plate is free to move (Fig. 43).

5. Start engine and rotate pump plate (Fig. 43) in either direction until wheel ceases rotation.

6. Stop engine and tighten locknuts to secure pump plate (Fig. 43).

7. Start engine and check adjustment. Repeat adjustment, if necessary.

8. Stop the engine and release right brake. Remove jack stands and lower machine to the shop floor. Test drive the machine to be sure it does not creep.

## CHANGING HYDRAULIC OIL AND FILTER

Initially, replace the hydraulic filter after the first full day's operation — **NOT TO EXCEED 10 HOURS.** Replace the filter every 200 hours thereafter. The hydraulic system is designed to operate on any high quality detergent oil having the American Petroleum Institute — API — "service classification" SF/CC or CD. Oil viscosity — weight — must be selected according to anticipated ambient temperature for the season in which product will be used.

Temperature/viscosity recommendations are:

<b>Expected Ambient Temperature</b>	<b>Recommended Viscosity and Type</b>
(Extreme) over 90° F	SAE 30, Type SF/CC or CD engine oil.
(Normal) 40-100° F	SAE 10W-30 or 10W-40. Type SF/CC or CD engine oil.
(Cool—Spring/Fall) 30-50° F	SAE 5W-30, Type SF/CC or CD engine oil.
(Winter) Below 30° F	Type "F" or "FA" ATF Automatic Transmission Fluid.

**Note:** Do not mix engine oil and automatic transmission fluid or hydraulic component damage may result. When changing fluids, also change transmission filter. **DO NOT USE DEXRON II ATF.**

**Note:** Fluid to operate the power steering is supplied by the hydraulic system transmission charge pump.

Cold weather start-up may result in "stiff" operation of the steering until the hydraulic system has warmed up. Using proper weight hydraulic oil in system will minimize this condition.

# MAINTENANCE

The axle housing acts as the reservoir for the system. The transmission and axle housing are shipped from the factory with approximately 5 quarts (4.7 l) of SAE 10W-30 engine oil. However, check level of transmission oil before engine is first started and daily thereafter.

1. Lower cutting unit to shop floor, set parking brake, and turn engine OFF. Block the two rear wheels.
2. Jack up both sides of the front axle and support it with jack stands.
3. Clean the area around the hydraulic oil filter and remove the filter (Fig. 44).

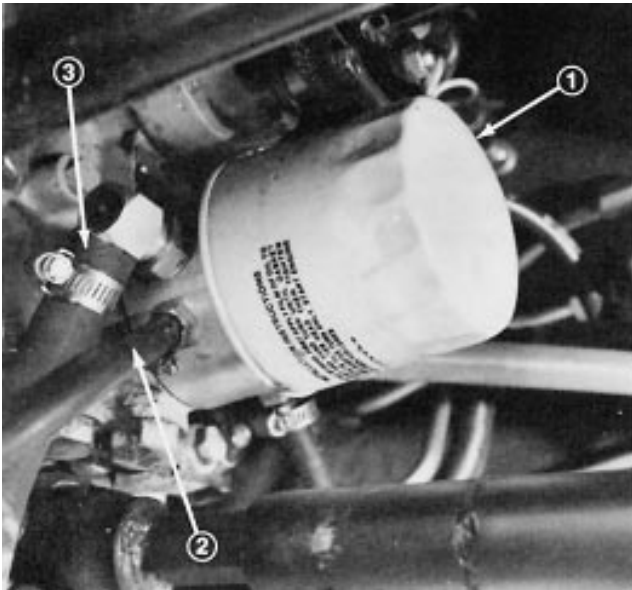

**Figure 44**

1. Hydraulic system filter
2. Hydraulic return lines
3. Suction line

4. Remove the tube that connects the axle housing to the transmission and allow the oil to flow into a drain pan.
5. Install new hydraulic oil filter and connect the tube between axle housing and transmission. Fill axle (reservoir) to proper level (approx. 5 qt); refer to Check Hydraulic System Fluid. Remove jack stands.
6. Start engine, cycle steering and lift cylinders, and check for oil leaks. allow engine to run for about five minute. Then shut engine off.
7. After two minutes, check level of transmission fluid; refer to Check Hydraulic System Fluid.

## ADJUSTING SERVICE BRAKES

Adjust the service brakes when there is more than one inch (25 mm) of “free travel” of the brake pedals, or when the brakes do not work effectively. Free travel is

the distance the brake pedal moves before braking resistance is felt.

The brakes should be checked for adjustment after the first 50 hours of operation and should only need adjusting after considerable use thereafter. These periodic adjustments can be performed where the brake cable connect to the bottom of the brake pedals. When the cable is no longer adjustable, the star nut on inside of the brake drum must be adjusted to move the brake shoes outward. However, the brake cables must be adjusted again to compensate for this adjustment.

1. Disengage lock arm from right brake pedal so both pedals work independently of each other.
2. To reduce free travel of brake pedals — tighten the brakes — loosen front nut on threaded end of brake cable (Fig. 45). Then tighten rear nut to move cable backward until brake pedals have 1/2 to 1 inch (13 mm to 25 mm) of free travel. Tighten front nut after brakes are adjusted correctly.

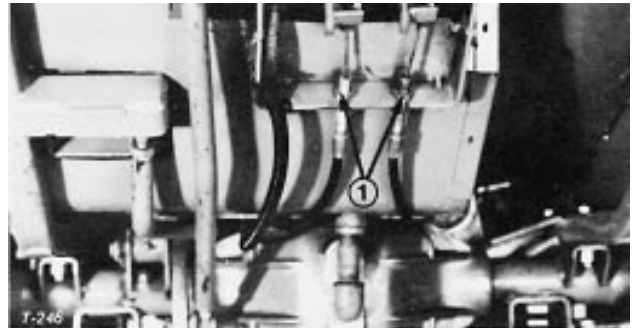

**Figure 45**

1. Jam nuts

## CHANGING REAR AXLE LUBRICANT

After every 400 hours of operation the oil in the rear axle must be changed.

1. Position machine on a level surface.
2. Clean area around the (3) drain plugs, (1) on each end and (1) in the center (Fig. 46).

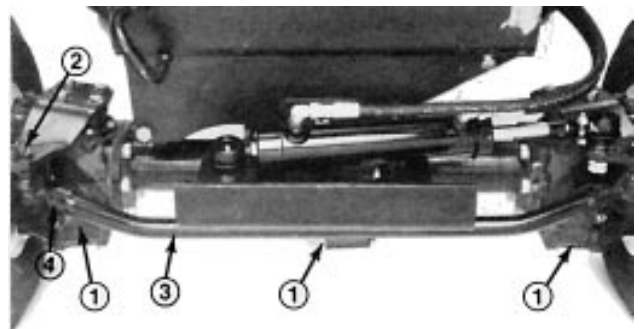

**Figure 46**

1. Drain plugs (3)
2. Ball joint
3. Tie Rod
4. Tie rod clamp

# MAINTENANCE

3. Remove plugs allowing oil to drain into drain pans.
4. After oil is drained, apply thread locking compound on drain plug threads and reinstall in axle.
5. Fill axle with lubricant; refer to Check Rear Axle Lubricant.

## REAR WHEEL TOE-IN

The rear wheels should not toe-in or toe-out when they are adjusted correctly. To check the rear wheel toe-in, measure the center-to-center distance at wheel hub height, in front and in back of the rear tires. If the wheels toe-in or toe-out, an adjustment is required.

1. Rotate the steering wheel so rear wheels are straight ahead.
2. Remove cotter pin and nut securing one tie rod ball joint to mounting bracket on axle and disconnect ball joint from axle (Fig. 46).
3. Loosen screw on tie rod clamp. Rotate ball joint in or out to adjust length of tie rod.
4. Reinstall ball joint to mounting bracket and check wheel toe-in.
5. After attaining desired adjustment, tighten screw on tie rod clamp and resecure ball joint to mounting bracket.

## ADJUSTING STEERING STOPS

The rear axle steering stops help prevent over travel of the steering cylinder in case of impact on rear wheels. The stops should be adjusted so there is .090" clearance between bolt head and knuckle on axle when steering wheel is completely turned left or right.

1. Thread bolt in or out until .090" clearance is attained (Fig. 47).

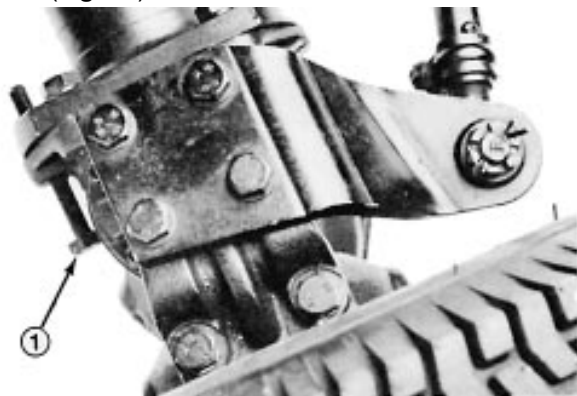

**Figure 47**

1. Steering Stops

## SERVICING BATTERY

**IMPORTANT:** Before welding on the machine, disconnect ground cable from the battery to prevent damage to the electrical system.

**Note:** Check battery condition weekly or after every 50 hours of operation. Keep terminals and entire battery case clean because a dirty battery will slowly discharge. To clean the battery wash the entire case with solution of baking soda and water. Rinse with clear water. Coat the battery posts and cable connector with Grafo 112X (Skin-over) grease, Toro Part No. 505-47 or petroleum jelly to prevent corrosion.

## WIRING HARNESS SERVICE

Prevent corrosion of wiring terminals by applying Grafo 112X (Skin-over) grease, Toro Part No. 505-47, to the inside of all harness connectors whenever the harness is replaced.

Whenever working with the electrical system, always disconnect battery cables, negative (-) cable first, to prevent possible wiring damage from short-outs.

## FUSES

Fuses are accessible under seat plate (Fig. 48).

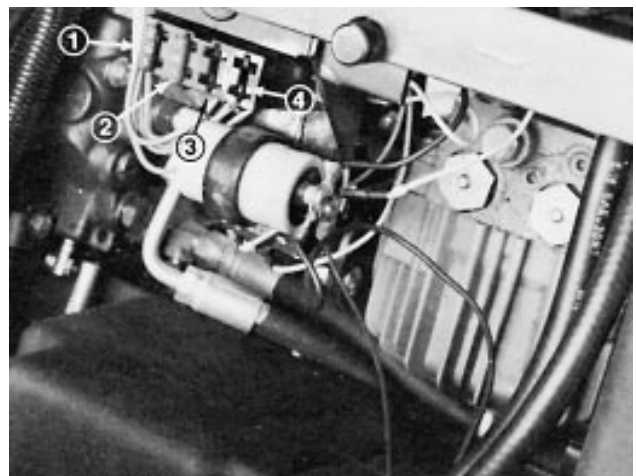
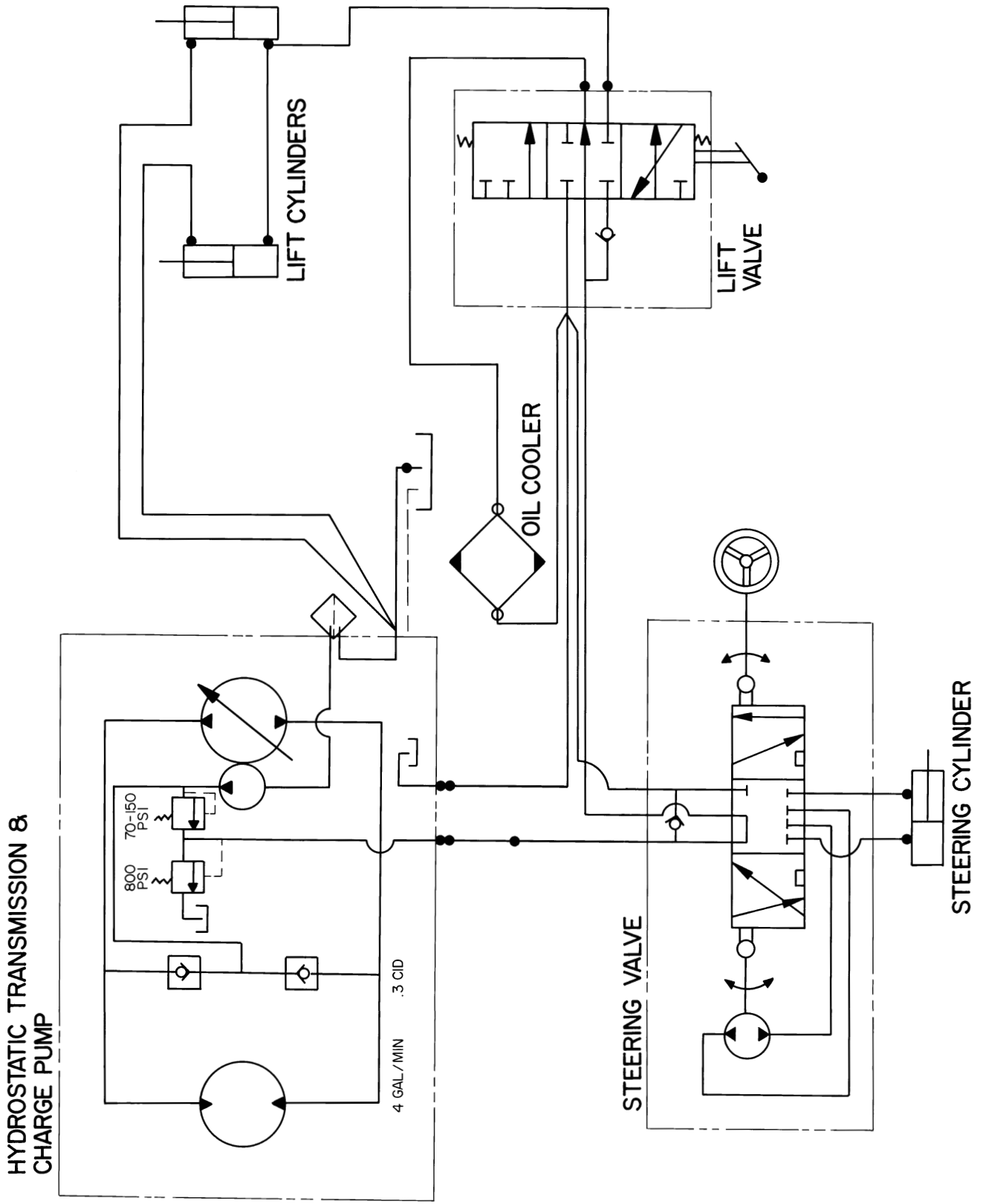

**Figure 48**

1. Accessories fuse (5 amp)
2. Safety switches fuse (5 amp)
3. Main fuse (7.5 amp)
4. Spare fuse (7.5 amp)



# HYDRAULIC SCHEMATIC



# MAINTENANCE SCHEDULE

## Minimum Recommended Maintenance Intervals

Maintenance Procedure	Maintenance Interval & Service			
<div style="border: 1px solid black; padding: 5px; margin-bottom: 5px;">                     Check Battery Fluid Level                      Check Battery Cable Connections                      Lubricate All Grease Fittings                      Lubricate Brake Cables                      Check Cutting Unit Gear Box Oil Level                      Clean Under Cutting Unit Belt Covers                      Check Cutting Unit Drive Belt Adjustment                      Change Engine Oil                      Inspect Air Filter, Dust Cup, and Baffle                 </div>	Every 50hrs	Every 100hrs	Every 200hrs	Every 400hrs
‡ Replace Engine Oil Filter Check Electric Clutch Gap Adjustment † Check PTO Belt Tension † Check Fan and Alternator Belt Tension Inspect Cooling System Hoses  Service Air Filter Check Rear Wheel Toe-In and Steering Linkage † Replace Transmission Filter † Torque Wheel Lug Nuts  Drain and Clean Fuel Tank Replace Cutting Unit Gear Box Oil Change Electric Fuel Pump Filter Change Fuel/Water Separator Filter Change Rear Axle Lubricant Coat Transmission Bypass Pins with Grease ‡ Torque Head, Adjust Valves and Check Engine RPM  † Initial break in at 10 hours ‡ Initial break in at 50 hours				
Replace Moving Hoses Replace Safety Switches Coolant System – Flush/Replace Fluid Replace Hydraulic Oil	<p><b><u>Annual Recommendations:</u></b>                      Items listed are recommended every 1000 hours or 2 years, whichever occurs first.</p>			

# PREPARATION FOR SEASONAL STORAGE

## Traction Unit

1. Thoroughly clean the traction unit, cutting unit and the engine, paying special attention to these areas:
  - radiator and radiator screen
  - underneath the cutting unit
  - under the cutting unit belt covers
  - counterbalance springs
  - P.T.O. Shaft Assembly
  - all grease fittings and pivot points
  - remove control panel and clean out inside of the control box
  - beneath seat plate and top of transmission
2. Check the tire pressure. Inflate all traction unit tires to 20 psi (138 kPa).
3. Remove, sharpen and balance the cutting unit's blades. Reinstall the blades and torque the blade fasteners to 85-110 ft-lb (115-149 N·m).
4. Check all fasteners for looseness; tighten as necessary.
5. Grease or oil all grease fittings, pivot points, and transmission by-pass valve pins. Wipe off any excess lubricant.
6. Lightly sand and use touch up paint on painted areas that are scratched, chipped or rusted. Repair any dents in the metal body.
7. Service the battery and cables as follows:
  - a. Remove the battery terminals from the battery posts.

- b. Clean the battery, terminals and posts with a wire brush and baking soda solution.
- c. Coat the cable terminals and battery posts with Grafo 112X skin-over grease (Toro Part Number 505-47), or petroleum jelly to prevent corrosion.
- d. Slowly recharge the battery for 24 hours every 60 days to prevent lead sulfation of the battery.

## Engine

1. Drain the engine oil from the oil pan and replace the drain plug.
2. Remove and discard the oil filter. Install a new filter.
3. Refill the engine with 3.8 quarts (3.6 l) of recommended motor oil. Refer to Changing Crankcase Oil.
4. Start the engine and run at idle speed for two minutes.
5. Drain diesel fuel from the fuel tank, fuel lines, pump, filter and separator. Flush fuel tank with clean diesel fuel and connect all fuel lines.
6. Thoroughly clean and service the air cleaner assembly.
7. Seal the air cleaner inlet and the exhaust outlet with weather proof masking tape.
8. Check the oil filler cap and fuel tank cap to ensure they are securely in place.

# PRODUCT IDENTIFICATION

The traction unit has two identification numbers: a model number and a serial number that are stamped into a plate. The identification plate is located near the left brake pedal on the frame (Fig. 49). In any correspondence concerning the traction unit, supply the model and serial numbers to ensure correct information and replacement parts are obtained.

To order replacement parts from an Authorized TORO Distributor supply the following information:

1. Model and serial numbers of the traction unit.
2. Part number, description and quantity of parts desired.

**Note:** Do not order by reference number if a parts catalog is being used; use the part number.

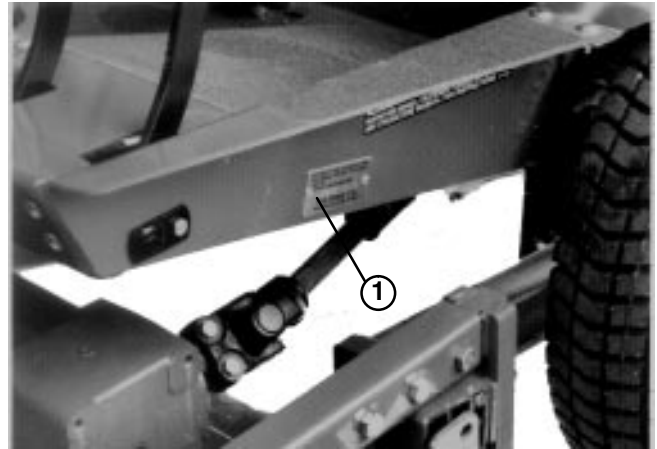

**Figure 49**

1. Model and serial ID plate

# The Toro Promise

## A Limited Warranty

The Toro Company promises to repair your Model 30243 TORO GROUNDMASTER® MOWER and its originally purchased cutting unit, if defective in materials or workmanship. The following time periods from the date of purchase apply (special warranty terms, on certain components, may be offered through The Toro Company by the component manufacturers):

**Model 30243 . . . . . Two Years or 1500 operational hours,  
whichever comes first**

*The cost of parts, labor and transportation are included.*

If you feel your TORO Product is defective and wish to rely on The Toro Promise, the following procedure is recommended:

1. Contact your Authorized TORO Distributor or Commercial Dealer (the Yellow Pages of your telephone directory is a good reference source).
2. The TORO Distributor or Commercial Dealer will advise you on the arrangements that can be made to inspect and repair your product.
3. The TORO Distributor or Commercial Dealer will inspect the product and advise you whether the product is defective and, if so, make all repairs necessary to correct the defect without an extra charge to you.

If for any reason you are dissatisfied with the distributor's analysis of the defect or the service performed, you may contact us.

Write:

TORO Commercial Products Service Department  
8111 Lyndale Avenue South  
Minneapolis, MN 55420-1196

The above remedy of product defects through repair by an Authorized TORO Distributor or Commercial Dealer is the purchaser's sole remedy for any defect.

**THERE IS NO OTHER EXPRESS WARRANTY. ALL IMPLIED WARRANTIES OF MERCHANTABILITY AND FITNESS FOR USE ARE LIMITED TO THE DURATION OF THE EXPRESS WARRANTY.**

Some states do not allow limitations on how long an implied warranty lasts, so the above limitation may not apply to you.

This Warranty applies only to parts or components which are defective and does not cover repairs necessary due to normal wear, misuse, accidents, or lack of proper maintenance. Regular, routine maintenance of the unit to keep it in proper operating condition is the responsibility of the owner.

All warranty repairs reimbursable under The Toro Promise must be performed by an Authorized Toro Commercial Dealer or Distributor using Toro approved replacement parts.

Repairs or attempted repairs by anyone other than an Authorized TORO Distributor or Commercial Dealer are not reimbursable under the TORO Promise. In addition, these unauthorized repair attempts may result in additional malfunctions, the correction of which is not covered by warranty.

**THE TORO COMPANY IS NOT LIABLE FOR INDIRECT, INCIDENTAL OR CONSEQUENTIAL DAMAGES IN CONNECTION WITH THE USE OF THE PRODUCT INCLUDING ANY COST OR EXPENSE OF PROVIDING SUBSTITUTE EQUIPMENT OR SERVICE DURING PERIODS OF MALFUNCTION OR NON-USE.**

Some states do not allow the exclusion of incidental or consequential damages, so the above exclusion may not apply to you.

This warranty gives you specific legal rights, and you may also have other rights which vary from state to state.

### COUNTRIES OTHER THAN THE UNITED STATES OR CANADA

Customers who have purchased TORO products exported from the United States or Canada should contact their TORO Distributor (Dealer) to obtain guarantee policies for your country, province, or state. If for any reason you are dissatisfied with your Distributor's service or have difficulty obtaining guarantee information, contact the TORO importer. If all other remedies fail, you may contact us at The Toro Company.