



Count on it.

Operator's Manual

**Groundsmaster® 4000-D and
4010-D Rotary Mower**

Model No. 30446N—Serial No. 313000001 and Up

Model No. 30448N—Serial No. 313000001 and Up



WARNING

CALIFORNIA Proposition 65 Warning

Diesel engine exhaust and some of its constituents are known to the State of California to cause cancer, birth defects, and other reproductive harm.

Because in some areas there are local, state, or federal regulations requiring that a spark arrester be used on the engine of this machine, a spark arrester is incorporated with the muffler assembly.

Genuine Toro spark arresters are approved by the USDA Forestry Service.

Important: This engine is equipped with a spark arrester muffler. It is a violation of California Public Resource Code Section 4442 to use or operate the engine on any forest-covered, brush-covered, or grass-covered land without a spark arrester muffler maintained in working order, or the engine constricted, equipped, and maintained for the prevention of fire. Other states or federal areas may have similar laws.

Introduction

This machine is a ride-on, rotary-blade lawnmower intended to be used by professional, hired operators in commercial applications. It is primarily designed for cutting grass on well-maintained lawns in parks, sports fields, and on commercial grounds. It is not designed for cutting brush, mowing grass and other growth alongside highways, or for agricultural uses.

Read this information carefully to learn how to operate and maintain your product properly and to avoid injury and product damage. You are responsible for operating the product properly and safely.

You may contact Toro directly at www.Toro.com for product and accessory information, help finding a dealer, or to register your product.

Whenever you need service, genuine Toro parts, or additional information, contact an Authorized Service Dealer or Toro Customer Service and have the model and serial numbers of your product ready. Write the numbers in the space provided.

Model No. _____

Serial No. _____

This manual identifies potential hazards and has safety messages identified by the safety alert symbol (Figure 1), which signals a hazard that may cause serious injury or death if you do not follow the recommended precautions.



Figure 1

1. Safety alert symbol

This manual uses 2 other words to highlight information.

Important calls attention to special mechanical information and **Note** emphasizes general information worthy of special attention.

Contents

Safety	4	Replacing the Hydraulic Filters	49
Safe Operating Practices	4	Checking the Hydraulic Lines and Hoses	49
Toro Mower Safety	6	Adjusting the Counterbalance Pressure	49
Engine Emission Certification	7	Mower Maintenance	50
Safety and Instructional Decals	8	Adjusting the Transport Latch	50
Setup	14	Pivoting (Tilting) the Front Cutting Unit	
1 Greasing the Machine	14	Upright	51
Product Overview	14	Pivoting the Front Cutting Unit Down	51
Controls	14	Adjusting the Cutting Unit Pitch	51
Specifications	18	Servicing the Castor Arm Bushings	52
Attachments/Accessories	18	Servicing the Castor Wheels and Bearings	52
Operation	19	Blade Maintenance	53
Before Operating	19	Checking for a Bent Blade	53
Adjusting the Mirrors	28	Removing and Installing the Cutter Blade(s)	53
Aiming the Headlights	28	Inspecting and Sharpening the Cutter Blade(s)	54
Starting and Stopping the Engine	28	Correcting Cutting Unit Mismatch	55
Engine Cooling Fan Operation	29	Spark Arrestor Maintenance	56
Checking the Interlock Switches	29	Servicing the Spark Arrestor Muffler	56
Pushing or Towing the Machine	29	Cab Maintenance	56
Jacking Points	30	Cleaning the Cab Air Filters	56
Tie Downs	30	Cleaning the Air Conditioning Coil	57
Operating Characteristics	31	Cleaning the A/C Condenser Screen	57
Operating Tips	32	Storage	58
Maintenance	33	Preparing for Seasonal Storage	58
Recommended Maintenance Schedule(s)	33	Schematics	59
Service Interval Chart	34		
Lubrication	35		
Greasing the Bearings and Bushings	35		
Engine Maintenance	38		
Air Cleaner Maintenance	38		
Servicing the Engine Oil and Filter	39		
Fuel System Maintenance	39		
Servicing the Fuel System	39		
Servicing the Water Separator	39		
Bleeding Air from the Injectors	40		
Electrical System Maintenance	40		
Battery Care	40		
Fuses	41		
Drive System Maintenance	43		
Changing the Planetary Gear Drive Oil	43		
Changing the Rear Axle Lubricant	43		
Checking the Rear Wheel Toe-In	44		
Cooling System Maintenance	44		
Servicing the Engine Cooling System	44		
Brake Maintenance	45		
Adjusting the Service Brakes	45		
Belt Maintenance	46		
Servicing the Alternator Belt	46		
Servicing the Compressor Belt	46		
Re-tensioning the Blade Drive Belts	46		
Replacing the Blade Drive Belt	46		
Controls System Maintenance	47		
Adjusting the Throttle Cable	47		
Adjusting the Traction Pedal Linkage	47		
Hydraulic System Maintenance	48		
Changing the Hydraulic Fluid	48		

Safety

This machine meets or exceeds ISO standard 5395:1990 and ANSI B71.4-2004 specifications in effect at the time of production.

Improper use or maintenance by the operator or owner can result in injury. To reduce the potential for injury, comply with these safety instructions and always pay attention to the safety alert symbol, which means Caution, Warning, or Danger—personal safety instruction. Failure to comply with the instruction may result in personal injury or death.

Safe Operating Practices

The following instructions are from the CEN standard EN 836:1997, ISO standard 5395:1990, and ANSI standard B71.4-2004.

Training

- Read the *Operator's Manual* and other training material carefully. Be familiar with the controls, safety signs, and the proper use of the equipment.
- Never allow children or people unfamiliar with these instructions to use the mower. Local regulations may restrict the age of the operator.
- Never mow while people, especially children, or pets are nearby.
- Keep in mind that the operator or user is responsible for accidents or hazards occurring to himself or herself, other people, or property.
- Do not carry passengers.
- All drivers and mechanics should seek and obtain professional and practical instruction. The owner is responsible for training the users. Such instruction should emphasize:
 - the need for care and concentration when working with ride-on machines;
 - control of a ride-on machine sliding on a slope will not be regained by the application of the brake. The main reasons for loss of control are:
 - ◇ insufficient wheel grip;
 - ◇ being driven too fast;
 - ◇ inadequate braking;
 - ◇ the type of machine is unsuitable for its task;
 - ◇ lack of awareness of the effect of ground conditions, especially slopes;
 - ◇ incorrect hitching and load distribution.

Preparation

- While mowing, always wear substantial footwear, long trousers, hard hat, safety glasses, and hearing protection. Long hair, loose clothing or jewelry may get tangled

in moving parts. Do not operate the equipment when barefoot or wearing open sandals.

- Thoroughly inspect the area where the equipment is to be used and remove all objects which may be thrown by the machine.
- **Warning**—fuel is highly flammable. Take the following precautions:
 - Store fuel in containers specifically designed for this purpose.
 - Refuel outdoors only and do not smoke while refuelling.
 - Add fuel before starting the engine. Never remove the cap of the fuel tank or add fuel while the engine is running or when the engine is hot.
 - If fuel is spilled, do not attempt to start the engine but move the machine away from the area of spillage and avoid creating any source of ignition until fuel vapors have dissipated.
 - Replace all fuel tank and container caps securely.
- Replace faulty silencers/mufflers.
- Before using, always visually inspect to see that the blades, blade bolts, and cutting assembly are not worn or damaged. Replace worn or damaged blades and bolts in sets to preserve balance.
- On multi-bladed machines, take care as rotating one blade can cause other blades to rotate.
- Evaluate the terrain to determine what accessories and attachments are needed to properly and safely perform the job. Only use accessories and attachments approved by the manufacturer.
- Check that operators presence controls, safety switches, and shields are attached and functioning properly. Do not operate unless they are functioning properly.

Operation

- Do not operate the engine in a confined space where dangerous carbon monoxide fumes can collect.
- Mow only in daylight or in good artificial light.
- Before attempting to start the engine, disengage all blade attachment clutches, shift into neutral, and engage the parking brake. Only start the engine from the operator's position. Use the seat belts.
- Remember there is no such thing as a safe slope. Travel on grass slopes requires particular care. To guard against overturning:
 - Do not stop or start suddenly when going up or downhill.
 - The machine speed should be kept low on slopes and during tight turns.
 - Stay alert for humps and hollows and other hidden hazards.
 - Never mow across the face of the slope, unless the machine is designed for that purpose.

- Stay alert for holes in the terrain and other hidden hazards.
- Use care when using heavy equipment.
 - Do not turn sharply. Use care when reversing.
 - Use counterweight(s) or wheel weights when suggested in the *Operator's Manual*.
- Watch out for traffic when crossing or near roadways.
- Stop the blades from rotating before crossing surfaces other than grass.
- When using any attachments, never direct discharge of material toward bystanders nor allow anyone near the machine while in operation.
- Never operate the machine with damaged guards, shields, or without safety protective devices in place. Be sure all interlocks are attached, adjusted properly, and functioning properly.
- Do not change the engine governor settings or overspeed the engine. Operating the engine at excessive speed may increase the hazard of personal injury.
- Before leaving the operators position:
 - Stop on level ground.
 - Disengage the power take-off and lower the attachments.
 - Change into neutral and set the parking brake.
 - Stop the engine and remove the key.
- Disengage drive to attachments, stop the engine, and remove the ignition key:
 - before clearing blockages;
 - before checking, cleaning, or working on the machine;
 - after striking a foreign object. Inspect the machine for damage and make repairs before restarting and operating the equipment. Torque all the spindle pulley nuts to 130 to 150 ft-lb (176 to 203 N·m);
 - if the machine starts to vibrate abnormally (check immediately).
- Disengage drive to attachments when transporting or not in use.
- Stop the engine and disengage drive to attachment:
 - before refuelling;
 - before making height adjustment unless adjustment can be made from the operator's position.
- Reduce the throttle setting before stopping engine and close the fuel shut-off valve at the conclusion of mowing.
- Never raise deck with the blades running.
- Keep hands and feet away from the cutting units.
- Look behind and down before backing up to be sure of a clear path.
- Slow down and use caution when making turns and crossing roads and sidewalks.
- Do not operate the mower under the influence of alcohol or drugs.
- Lightning can cause severe injury or death. If lightning is seen or thunder is heard in the area, do not operate the machine; seek shelter.
- Use care when loading or unloading the machine into a trailer or truck.
- The operator shall turn on flashing warning lights, if provided, whenever traveling on a public road, except where such use is prohibited by law.

Maintenance and Storage

- Keep all nuts, bolts, and screws tight to be sure the equipment is in safe working condition.
- Never store the equipment with fuel in the tank inside a building where fumes may reach an open flame or spark.
- Allow the engine to cool before storing in any enclosure and do not store near flame.
- To reduce the fire hazard, keep the engine, silencer/muffler, battery compartment, cutting units, drives, and fuel storage area free of grass, leaves, or excessive grease. Clean up oil or fuel spillage.
- Replace worn or damaged parts for safety.
- If the fuel tank has to be drained, do this outdoors.
- On multi-bladed machines, take care as rotating one blade can cause other blades to rotate.
- When machine is to be parked, stored, or left unattended, lower the cutting units unless a positive mechanical lock is provided.
- Disengage drives, lower the cutting units, move traction pedal to Neutral, set parking brake, stop engine and remove key . Wait for all movement to stop before adjusting, cleaning or repairing.
- Shut off fuel while storing or transporting. Do not store fuel near flames.
- Park machine on level ground. Never allow untrained personnel to service machine.
- Use jack stands to support components when required.
- Carefully release pressure from components with stored energy.
- Disconnect battery before making any repairs. Disconnect the negative terminal first and the positive last. Reconnect positive first and negative last.
- Use care when checking blades. Wrap the blades or wear gloves, and use caution when servicing them. Only replace blades. Never straighten or weld them.
- Keep hands and feet away from moving parts. If possible, do not make adjustments with the engine running.
- Charge batteries in an open well ventilated area, away from spark and flames. Unplug charger before connecting or disconnecting from battery. Wear protective clothing and use insulated tools.

- Make sure all hydraulic line connectors are tight and all hydraulic hoses and lines are in good condition before applying pressure to the system.
- Keep your body and hands away from pin hole leaks or nozzles that eject hydraulic fluid under high pressure. Use paper or cardboard, not your hands, to search for leaks. Hydraulic fluid escaping under pressure can have sufficient force to penetrate the skin and cause serious injury. If fluid is injected into the skin it must be surgically removed within a few hours by a doctor familiar with this form of injury or gangrene may result.
- Avoid starting or stopping on a slope. If tires lose traction, disengage the blades and proceed slowly straight down the slope. Avoid raising the side cutting units on a slope.
- Avoid turning on slopes. If you must turn, turn slowly and gradually downhill, if possible.
- When operating a machine with a ROPS, always use a seat belt.
- Be certain that the seat belt can be released quickly if the machine is driven or rolls into a pond or water.
- Watch for traffic when near or crossing roads. Always yield the right-of-way.
- This machine is not designed or equipped for on-road use and is a “slow-moving vehicle”. If you must cross or travel on a public road, you should be aware of and comply with local regulations, such as required lights, slow moving vehicle signs, and reflectors.
- Do not mow near drop-offs, ditches, or embankments. The machine could suddenly turn over if a wheel goes over the edge of a cliff or ditch, or if an edge caves in.
- Do not mow on wet grass. Reduced traction could cause sliding.
- Use extra care with other attachments. These can change the stability of the machine.
- Turn off the blades when not mowing.

Toro Mower Safety

The following list contains safety information specific to Toro products or other safety information that you must know that is not included in the standards.

This product is capable of amputating hands and feet and throwing objects. Always follow all safety instructions to avoid serious injury or death.

Use of this product for purposes other than its intended use could prove dangerous to user and bystanders.

▲ WARNING

Engine exhaust contains carbon monoxide, which is an odorless, deadly poison that can kill you.

Do not run engine indoors or in an enclosed area.

Operation

- Before operating a machine with ROPS (roll over protection system), be certain that the seat belts are attached and the seat is latched to prevent the seat from pivoting forward.
- Know how to stop the machine and engine quickly.
- Do not operate the machine while wearing tennis shoes or sneakers.
- Wearing safety shoes and long pants is advisable and required by some local ordinances and insurance regulations.
- Keep hands, feet, and clothing away from moving parts and the mower discharge area and underside of the mower while the engine is running.
- Fill fuel tank until level is 1 inch (25 mm) below the bottom of the filler neck. Do not overfill.
- Check the safety interlock switches daily for proper operation. If a switch should fail, replace the switch before operating the machine.
- Check carefully for overhead clearances (i.e. branches, doorways, electrical wires) before driving under any objects and do not contact them.
- Do not mow in reverse unless absolutely necessary.
- Reduce speed when making sharp turns.

Maintenance and Storage

- Do not touch equipment or attachment parts which may be hot from operation. Allow to cool before attempting to maintain, adjust, or service.
- Never store the machine or fuel container inside where there is an open flame, such as near a water heater or furnace.
- Keep nuts and bolts tight, especially the blade attachment bolts. Keep equipment in good condition.
- If the engine must be running to perform a maintenance adjustment, keep hands, feet, clothing, and any parts of the body away from the cutting units, attachments, and any moving parts. Keep everyone away.
- Check brake operation frequently. Adjust and service as required.
- Battery acid is poisonous and can cause burns. Avoid contact with skin, eyes, and clothing. Protect your face, eyes, and clothing when working with a battery.
- Battery gases can explode. Keep cigarettes, sparks, and flames away from the battery.
- The engine must be shut off before checking the oil or adding oil to the crankcase.
- If major repairs are ever needed or if assistance is desired, contact an Authorized Toro Distributor.
- To make sure of optimum performance and continued safety certification of the machine, use only genuine Toro

replacement parts and accessories. Replacement parts and accessories made by other manufacturers could be dangerous, and such use could void the product warranty.

Engine Emission Certification

The engine in this machine is EPA Tier 4i compliant.

Safety and Instructional Decals



Safety decals and instructions are easily visible to the operator and are located near any area of potential danger. Replace any decal that is damaged or lost.

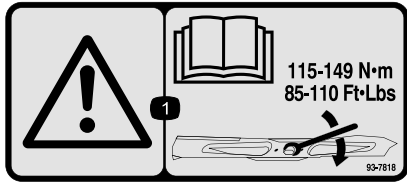

93-7818

- Warning—read the *Operator's Manual* for instructions on torquing the blade bolt/nut to 115-149 N-m (85-110 ft-lb).

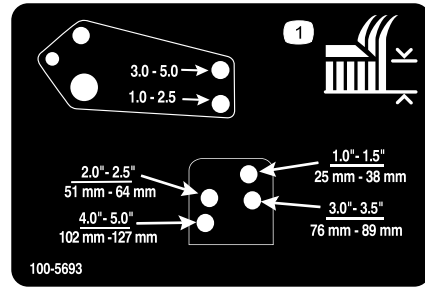

100-5693

- Height of cut adjustment

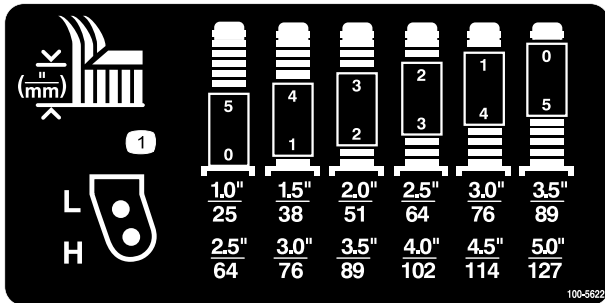

100-5622

- Height of cut adjustment

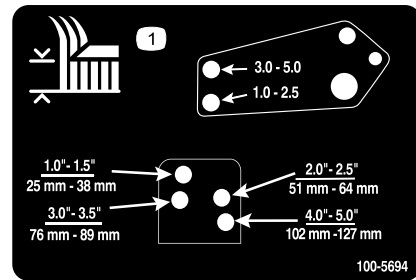

100-5694

- Height of cut adjustment

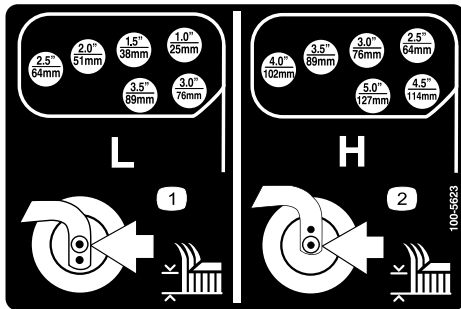

100-5623

- Low height of cut adjustment
- High height of cut adjustment

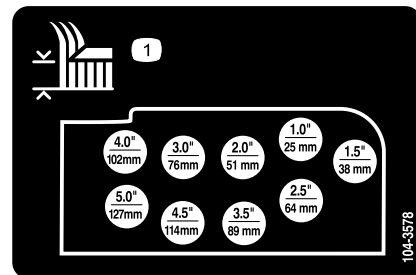

104-3578

- Height of cut adjustment

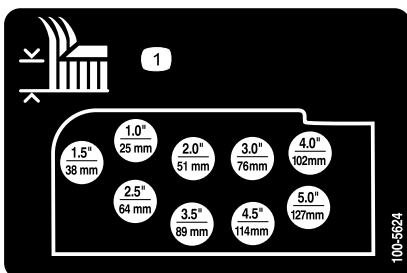

100-5624

- Height of cut adjustment

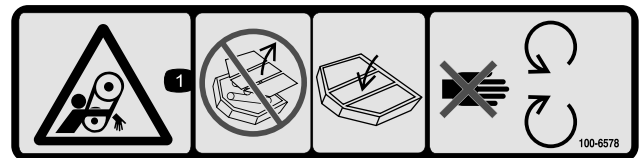

100-6578

- Entanglement hazard, belt—do not operate the machine with the shields or guards removed; always keep the shields and guards in place; stay away from moving parts.

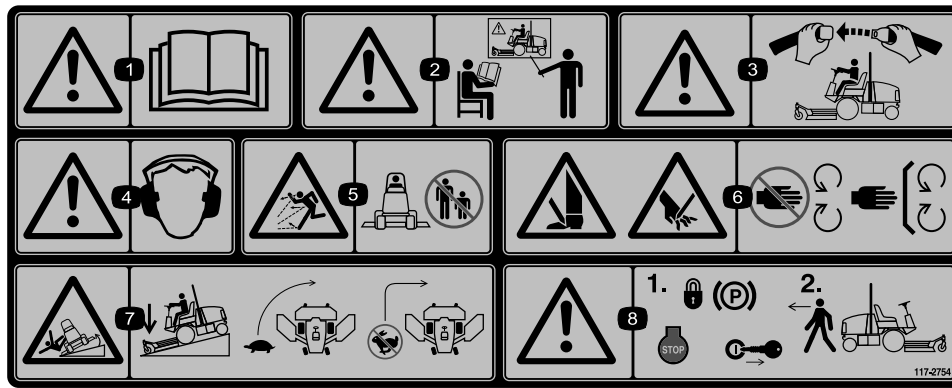

117-2754

1. Warning—read the *Operator's Manual*.
2. Warning—do not operate this machine unless you are trained.
3. Warning—wear the seat belt when seated in the operator's position.
4. Warning—wear hearing protection.
5. Thrown object hazard—keep bystanders a safe distance from the machine.
6. Cutting hazard of hand or foot—stay away from moving parts; keep all guards in place.
7. Tipping hazard—lower the cutting unit when driving down slopes; slow machine before turning, do not turn at high speeds
8. Warning—lock the parking brake, stop the engine and remove the ignition key before leaving the machine.

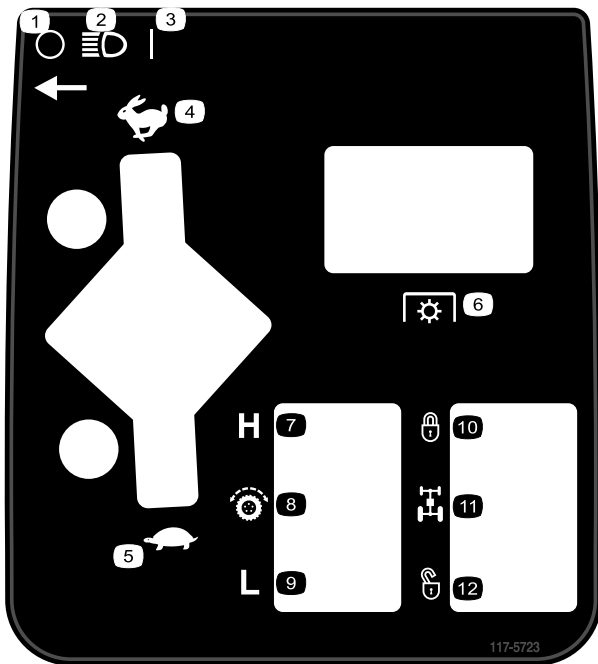

117-5723

- | | |
|-------------------------|---------------------|
| 1. Off | 7. High |
| 2. Headlights | 8. Traction control |
| 3. On | 9. Low |
| 4. Fast | 10. Locked |
| 5. Slow | 11. Flow divider |
| 6. Power Take-off (PTO) | 12. Unlocked |

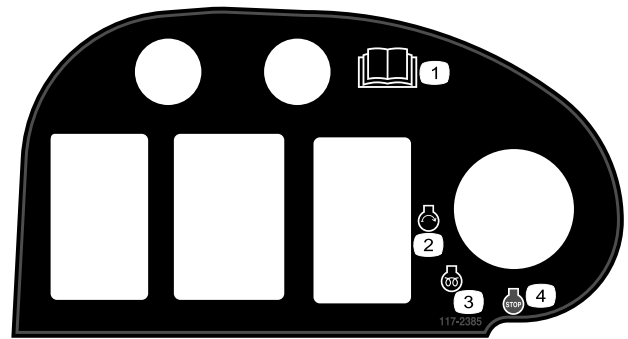

117-2385

- | | |
|---------------------------------------|-------------------|
| 1. Read the <i>Operators Manual</i> . | 3. Engine—preheat |
| 2. Engine—start | 4. Engine—stop |

CALIFORNIA SPARK ARRESTER WARNING

Operation of this equipment may create sparks that can start fires around dry vegetation. A spark arrester may be required. The operator should contact local fire agencies for laws or regulations relating to fire prevention requirements. 117-2718

117-2718

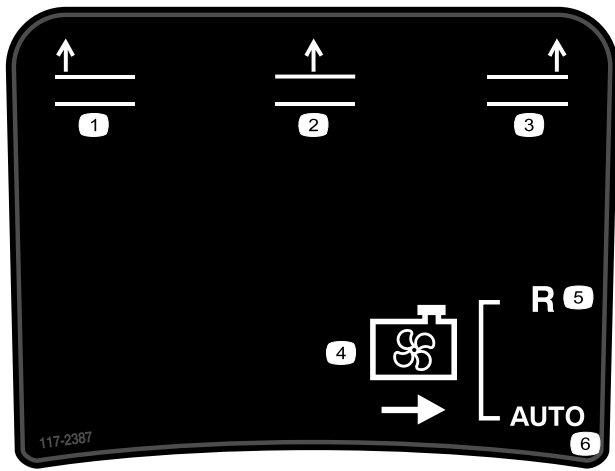

117-2387

1. Raise left deck
2. Raise center deck
3. Raise right deck
4. Cooling fan
5. Reverse
6. Automatic

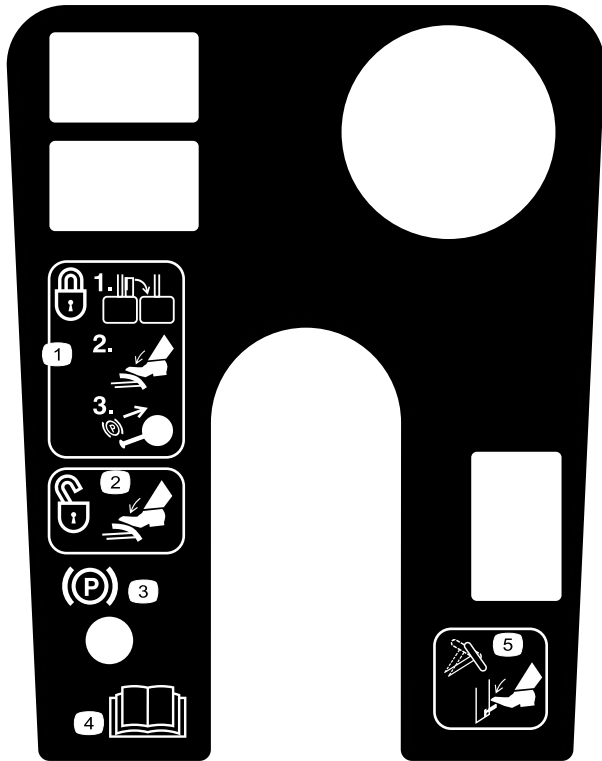

119-0067

1. To lock the parking brake, latch the pedals together, apply the brake pedals, and pull up on the knob.
2. To unlock the parking brake, step on the brake pedals.
3. Parking brake lock indicator
4. Read the *Operator's Manual*.
5. Press down on the lever to tilt the steering wheel.

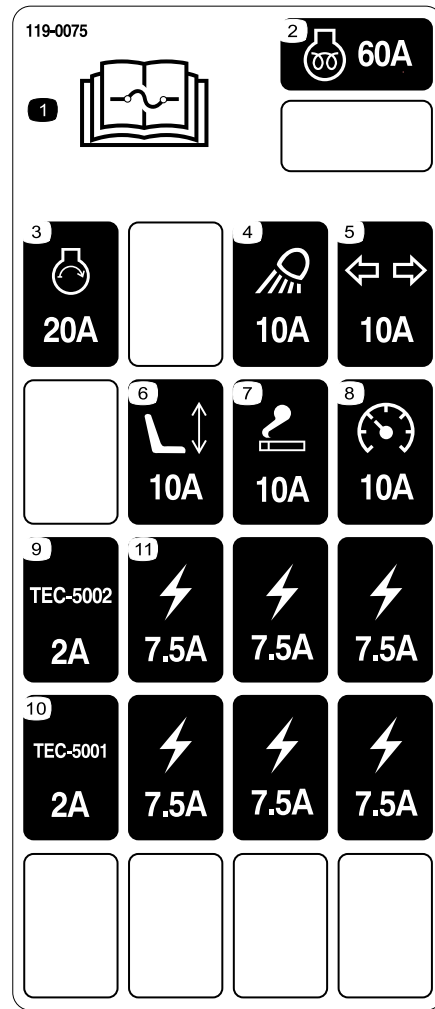

119-0075

1. Read the *Operator's Manual* for fuse information.
2. Engine preheat—60A fuse
3. Engine, start—20A fuse
4. Headlights—10A fuse
5. Turn signal—10A fuse
6. Power seat—10A fuse
7. Powerpoint—10A fuse
8. Instruments—10A fuse
9. Control module—2A fuse
10. Control module—2A fuse
11. Powerpoint—7.5A fuse



58-6520

1. Grease

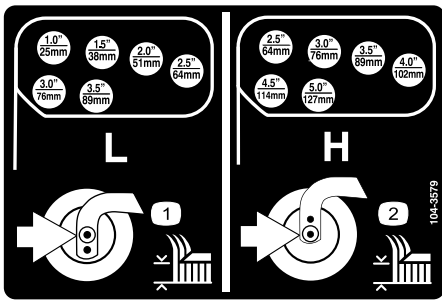

104-3579

1. Low height of cut adjustment
2. High height of cut adjustment

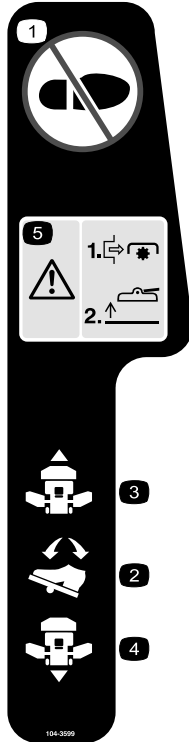

104-3599

1. Do not step here.
2. Traction pedal
3. Traction—forward
4. Traction—reverse
5. Danger—shut off PTO prior to raising the cutting units; do not operate the cutting units when they are in the raised position.

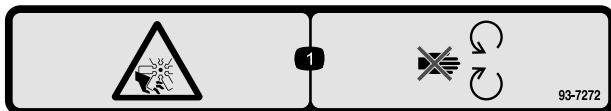

93-7272

1. Cutting/dismemberment hazard; fan—stay away from moving parts.

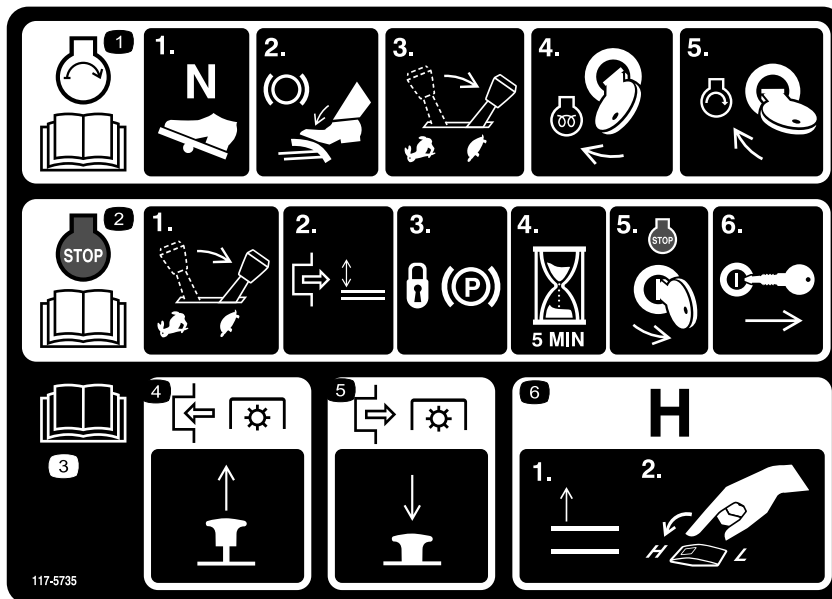

117-5735

1. Read the *Operators Manual*; to start the engine, move the traction pedal to Neutral, apply the brake, move the throttle switch to slow, turn the ignition key to Preheat. When the Wait to Start Advisory clears on the Info Center then turn the ignition key to Start.
2. Read the *Operators Manual*; to stop the engine, move the throttle lever to slow, disengage the PTO, set the parking brake, wait 5 minutes, turn the ignition key to Stop, and remove the key; read the *Operators Manual*.
3. Read the *Operators Manual*.
4. To engage the PTO, pull up on the PTO switch.
5. To disengage the PTO, push down on the PTO switch.
6. To switch the transmission to high speed, fully raise the attachments and switch the speed control to High.

GROUNDMASTER 4000 1

QUICK REFERENCE AID 1

CHECK/SERVICE (DAILY)

1. ENGINE OIL LEVEL	8. AIR CLEANER
2. HYDRAULIC FLUID LEVEL	9. BRAKE FUNCTION
3. ENGINE COOLANT LEVEL	10. INTERLOCK SYSTEM
4. FUEL - DIESEL ONLY	11. TIRE PRESSURE - 25 PSI/1.70 BAR
5. FUEL/WATER SEPARATOR	12. GREASE POINTS (6)
6. FAN BELT TENSION	SEE OPERATOR'S MANUAL FOR
7. RADIATOR SCREEN	50 HR INTERVAL GREASE POINTS.

SPECIFICATIONS/CHANGE INTERVALS

SEE OPERATOR'S MANUAL FOR INITIAL CHANGES.	FLUID TYPE	CAPACITY	CHANGE INTERVAL		FILTER PART NO.
			FLUID	FILTER	
ENGINE OIL	15W-40 CH-4, CI-4	10 QUARTS	150 HOURS	150 HOURS	104-5169(A)
HYDRAULIC FLUID	ISO VG 46/68	8 GALLONS	800 HOURS	800 HOURS	75-1310(B) 94-2621(C)
HYDRAULIC BREATHER				800 HRS/YRLY	68-6150(D)
PRIMARY AIR FILTER				SEE SERVICE INDICATOR	108-3814(E)
SAFETY AIR FILTER				SEE OPERATOR'S MANUAL	108-3816(F)
FUEL SYSTEM	> 32 F	NO. 2 DIESEL	19 GALLONS	800 HOURS DRAIN/FLUSH	400 HOURS/ YEARLY
	< 32 F	NO. 1 DIESEL			
REAR AXLE	85W-140	80 OUNCES	800 HOURS		110-9049(G) WATER SEPARATOR
PLANETARY DRIVE	85W-140	16 OUNCES	800 HOURS		110-4812(H) BREATHER
ENGINE COOLANT	50% WATER 50% ETHYL GLYCOL	13 QUARTS	DRAIN & FLUSH EVERY 2 YRS.		

115-8456

1. Read the *Operator's Manual*.



Battery Symbols

Some or all of these symbols are on your battery

- | | |
|--|--|
| 1. Explosion hazard | 6. Keep bystanders a safe distance from the battery. |
| 2. No fire, open flame, or smoking. | 7. Wear eye protection; explosive gases can cause blindness and other injuries |
| 3. Caustic liquid/chemical burn hazard | 8. Battery acid can cause blindness or severe burns. |
| 4. Wear eye protection | 9. Flush eyes immediately with water and get medical help fast. |
| 5. Read the <i>Operator's Manual</i> . | 10. Contains lead; do not discard. |

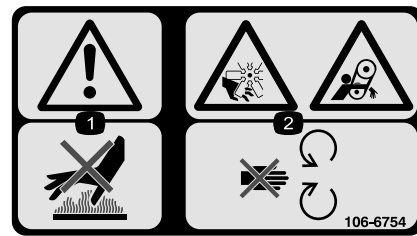

106-6754

- Warning—do not touch the hot surface.
- Cutting/dismemberment hazard, fan and entanglement hazard, belt—stay away from moving parts.



106-6755

- | | |
|---|--|
| 1. Engine coolant under pressure. | 3. Warning—do not touch the hot surface. |
| 2. Explosion hazard—read the <i>Operator's Manual</i> . | 4. Warning—read the <i>Operator's Manual</i> . |

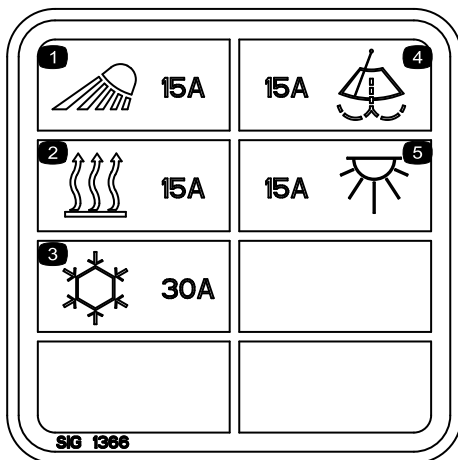

117-2787

- | | |
|-------------------------------|--------------------------------|
| 1. Headlights, 15A fuse | 4. Windshield wipers, 15A fuse |
| 2. Heater, 15A fuse | 5. Dome light, 15A fuse |
| 3. Air conditioning, 30A fuse | |



119-0124

(Model 30447 only)

- Warning—when the cab windows are open wear hearing protection.
- Close the rear window before attempting to open the hood.

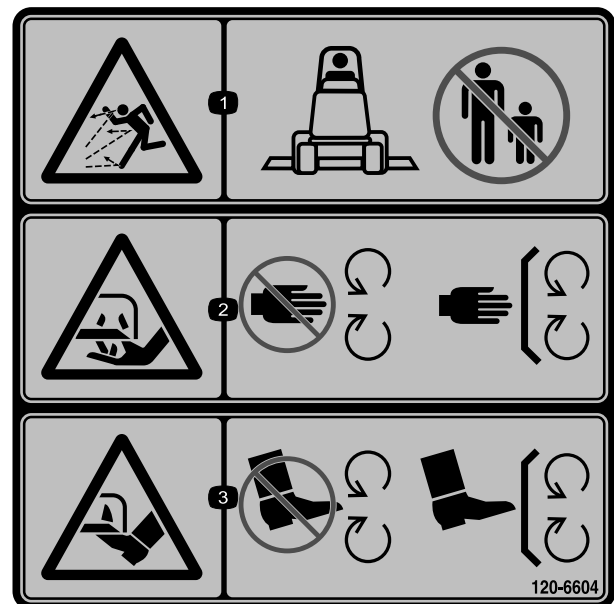

120-6604

- Thrown object hazard—keep bystanders away from the machine.
- Cutting/dismemberment hazard of hand, mower blade—stay away from moving parts, keep all guards and shields in place.
- Cutting/dismemberment hazard of foot, mower blade—stay away from moving parts, keep all guards and shields in place.

Setup

Loose Parts

Use the chart below to verify that all parts have been shipped.

Procedure	Description	Qty.	Use
1	No parts required	–	Grease the machine.

Media and Additional Parts

Description	Qty.	Use
Operator's Manual	1	Review before operating machine
Engine Operator's Manual	1	Use to reference engine information
Parts Catalog	1	Use to reference part numbers
Operator Training Materials	1	Review before operating machine
Pre-delivery Inspection Sheet	1	
Declaration of conformity	1	

Note: Determine the left and right sides of the machine from the normal operating position.



Greasing the Machine

No Parts Required

Procedure

Before the machine is operated, it must be greased to ensure proper lubricating characteristics; refer to Greasing the Bearings and Bushings in Lubrication. Failure to properly grease the machine will result in premature failure of critical parts.

Product Overview

Controls

Note: Determine the left and right sides of the machine from the normal operating position.

⚠ CAUTION

This machine produces sound levels in excess of 85 dBA at the operators ear and can cause hearing loss through extended periods of exposure.

Wear hearing protection when operating this machine.

Traction Pedal

To stop, reduce your foot pressure on the traction pedal and allow it to return to the center position (Figure 2).

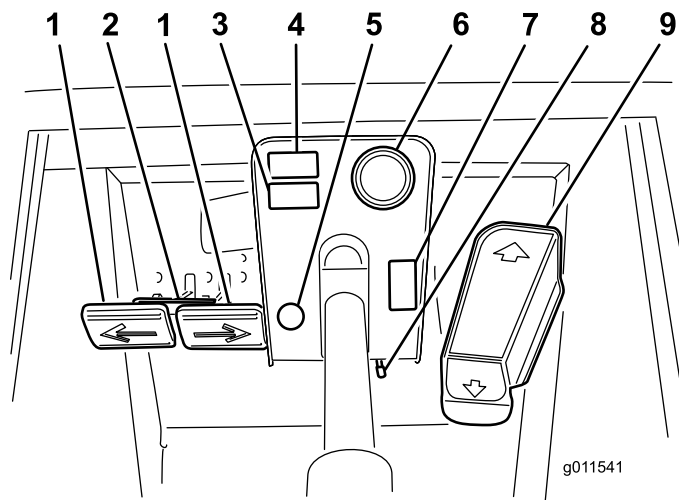

Figure 2

- | | |
|---------------------------------|------------------------|
| 1. Brake pedals | 6. Fuel gauge |
| 2. Pedal locking latch | 7. Hazard light switch |
| 3. Space for optional accessory | 8. Tilt steering lever |
| 4. Space for optional accessory | 9. Traction pedal |
| 5. Parking brake latch | |

Brake Pedals

Two foot pedals [Figure 2](#) operate individual wheel brakes for turning assistance, parking, and to aid in obtaining better side hill traction. A latch connects the pedals for parking brake operation and transport.

Pedal Locking Latch

The pedal locking latch [Figure 2](#) connects the pedals together to engage the parking brake.

Tilt Steering Lever

Press the lever [Figure 2](#) down to tilt the steering wheel to the desired position. Then release the lever to lock the adjustment.

Parking Brake Latch

A knob on the left side of the console actuates the parking brake lock ([Figure 2](#)). To engage the parking brake, connect the pedals with the locking latch, push down on both pedals, and pull the parking brake latch out. To release the parking brake, press both pedals until the parking brake latch retracts.

Fuel Gauge

The fuel gauge ([Figure 2](#)) indicates the level of fuel in the tank.

Hazard Light Switch

Press the hazard light switch ([Figure 2](#)) to activate the hazard lights.

Speed Limiter

If desired, the screw can be adjusted ([Figure 3](#)) to limit the amount the traction pedal can be depressed in the forward direction to limit the mowing speed.

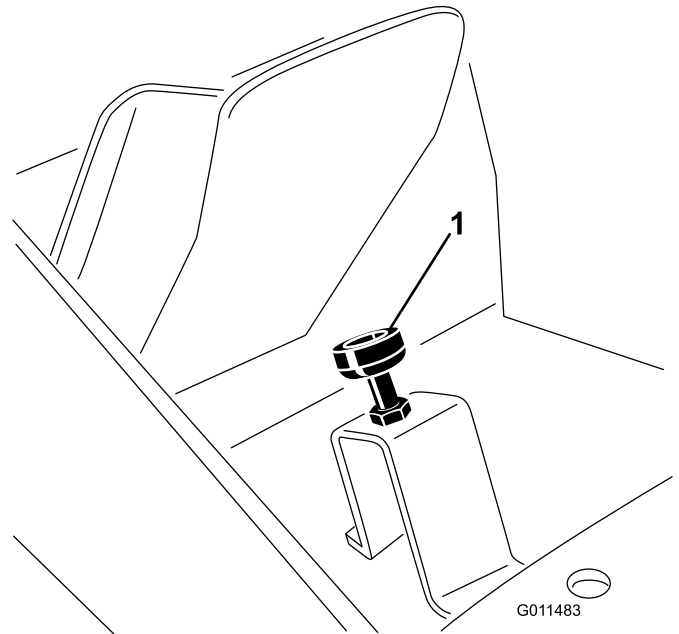

Figure 3

- | | |
|------------------|-------------|
| 1. Speed limiter | 2. Jam nuts |
|------------------|-------------|

Important: When in the mow position, the speed limiter screw must stop the traction pedal before the pump reaches full stroke or damage to the pump may occur.

Diagnostic Light

The diagnostic light ([Figure 4](#)) will illuminate should a system fault be recognized.

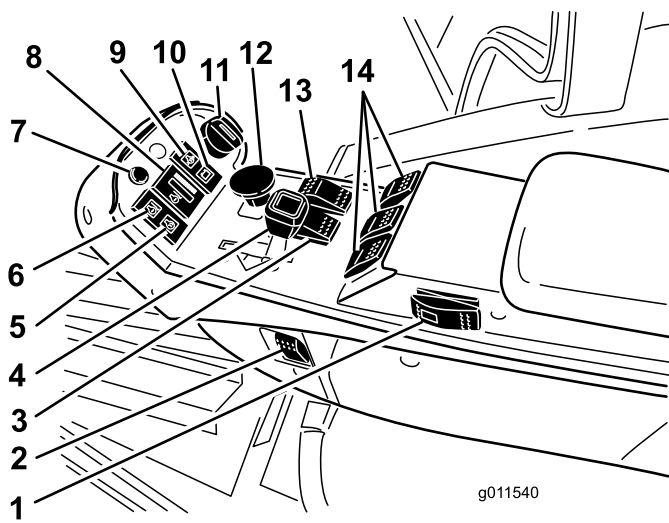

Figure 4

- | | |
|---|--------------------------------------|
| 1. Cruise control (optional) | 8. Engine coolant temperature gauge |
| 2. Light switch | 9. Engine oil pressure warning light |
| 3. Hi-Lo speed control | 10. Charge indicator |
| 4. Throttle control | 11. Key switch |
| 5. Glow plug indicator light | 12. PTO switch |
| 6. Engine coolant temperature warning light | 13. Flow divider switch |
| 7. Diagnostic light | 14. Lift switches |

Engine Coolant Temperature Gauge

During normal operating conditions the gauge (Figure 4) should be in the green range. Check the cooling system if the gauge goes to the yellow or red range.

Engine Oil Pressure Warning Light

The light (Figure 4) illuminates when the engine oil pressure is dangerously low.

Charge Indicator

The charge indicator (Figure 4) illuminates when the system charging circuit malfunctions.

Key Switch

The key switch (Figure 4) has three positions: Off, On/Preheat, and Start.

PTO Switch

The PTO switch (Figure 4) has two positions: Out (start) and In (stop). Pull the PTO button out to engage the cutting unit blades. Push in the button to disengage the cutting unit blades.

Flow Divider Switch

When operating in mow (low) speed, press and hold flow divider switch (Figure 4) to enhance traction drive performance in compromised operating conditions.

Hi-Lo Speed Control

The switch (Figure 4) allows the speed range to increase for transport of the machine. Cutting decks will not operate in high range. Also, the decks cannot be lowered from the transport position when the switch is in the high range. If the switch is moved from LO to HI with the cutting decks down and/or PTO on and/or cruise control engaged, the transmission will not change to HI. For the change to be accomplished, the switch must be moved to LO and all the requirements satisfied.

Lift Switches

The lift switches (Figure 4) raise and lower the cutting units. Press the switches forward to lower the cutting units and backward to raise the cutting units. When starting the machine, with the cutting units in the down position, press the lift switch down to allow the cutting units to float and mow.

Note: The decks will not lower while in the HI speed range and they will not raise or lower if the operator is out of the seat when the engine is running.

Throttle Control

Move the control (Figure 4) forward to increase the engine speed and rearward to decrease the speed.

Light Switch

Press the lower edge of the switch (Figure 4) to turn on the lights. Press the upper edge of the switch to turn off the lights.

Glow Plug Indicator Light

When lit, the glow plug indicator light (Figure 4) indicates that the glow plugs are on.

Engine Coolant Temperature Warning Light

The light (Figure 4) illuminates and the cutting units shut down (PTO disengages) if the engine reaches an unsafe operating temperature. If the temperature continues to rise the engine will shut down.

Engine Cooling Fan Switch

The machine is equipped with a hydraulically driven auto reversing engine cooling fan. The fan switch (Figure 5) has

two positions R (manual reverse) and Auto (normal). Refer to Engine Cooling Fan Operation in the Operation Section of manual.

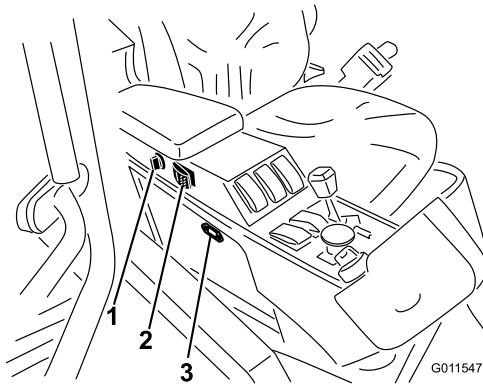

Figure 5

1. Power point
2. Engine cooling fan switch
3. Hour meter

Hour Meter

The hour meter (Figure 5) shows the total hours that the machine has been operated.

Power Point

The power point (Figure 5) is used to power optional electrical accessories.

Audible Alarm

To warn bystanders, an alarm will sound if the cutting decks are lowered with the engine off. The alarm will quit sounding once the deck lower switch is released. Also, the alarm will sound if the engine coolant temperature reaches a set-point that cuts out the PTO operation. The alarm will continue to sound until the coolant temperature drops below the set-point or the PTO switch is disengaged.

Cab Controls

Model 30446 only

Wind Shield Wiper Switch

Press front of switch to activate the wind shield wipers (Figure 6) and rear of switch to turn off the wipers.

Air Conditioning Switch

Press front of switch to activate the air conditioning (Figure 6) and rear of switch to turn off the air conditioning.

Fan Control

Rotate the fan control knob to regulate the speed of the fan (Figure 6).

Temperature Control

Rotate the temperature control knob to regulate the air temperature in the cab (Figure 6).

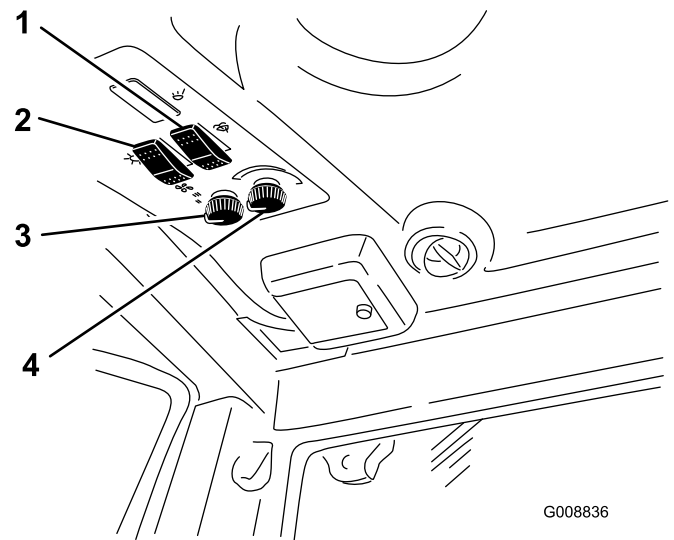

Figure 6

1. Wind shield wiper switch
2. Air conditioning switch
3. Fan control
4. Temperature control

Wind Shield Latch

Lift up on latches to open the wind shield (Figure 7). Press in on latch to lock wind shield in open position. Pull out and down on latch to close and secure wind shield.

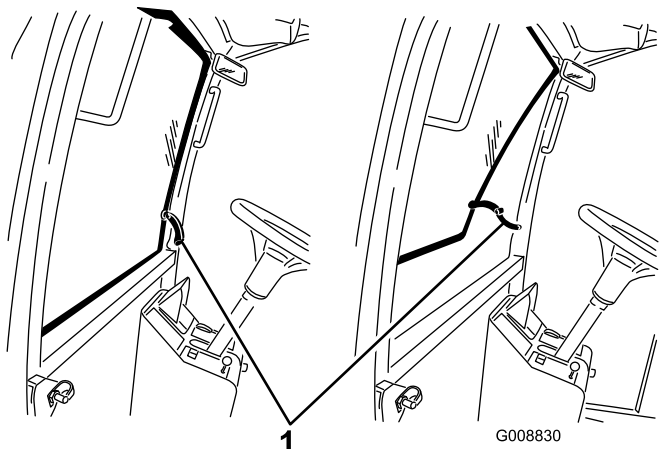

Figure 7

1. Wind shield latch

Rear Window Latch

Lift up on latches to open the rear window. Press in on latch to lock window in open position. Pull out and down on latch to close and secure window (Figure 7).

Important: The rear window must be closed before opening the hood or damage may occur.

Specifications

Note: Specifications and design are subject to change without notice.

Width of cut	
overall	132 inch (335 cm)
front cutting unit	62 inch (157 cm)
side cutting unit	42 inch (107 cm)
front and one side cutting unit	97 inch (246 cm)
Overall width	
cutting units down	136 inch (345 cm)
cutting units up (transports)	72 inch (183 cm)
Overall length	135 inch (342 cm)
Height	55 inch (140 cm)
Height with ROPS	81 inch (206 cm)
Height with cab	91 inch (231 cm)
Ground clearance	6-1/2 inch (17 cm)
Wheel tread (to center of tire)	
front	45 inch (114 cm)
rear	47 inch (119 cm)
Wheel base	55-1/2 in (141 cm)
(Net Weight)	4166 lb (1890 kg)
(Net Weight with cab)	4595 lb (2084 kg)

Attachments/Accessories

A selection of Toro approved attachments and accessories is available for use with the machine to enhance and expand its capabilities. Contact your Authorized Service Dealer or Distributor or go to www.Toro.com for a list of all approved attachments and accessories.

Operation

Note: Determine the left and right sides of the machine from the normal operating position.

Before Operating

⚠ CAUTION

If you leave the key in the ignition switch, someone could accidentally start the engine and seriously injure you or other bystanders.

Remove the key from the ignition before you do any maintenance.

Checking the Engine Oil

Service Interval: Before each use or daily

The engine is shipped with oil in the crankcase; however, the oil level must be checked before and after the engine is first started.

The crankcase capacity is 10 qt (9.5 l) with the filter.

Use high-quality engine oil that meets the following specifications:

- API Classification Level Required: CH-4, CI-4 or higher.
- Preferred oil: SAE 15W-40 (above 0°F)
- Alternate oil: SAE 10W-30 or 5W-30 (all temperatures)

Toro Premium Engine Oil is available from your distributor in either 15W-40 or 10W-30 viscosity. See the parts catalog for part numbers.

Note: The best time to check the engine oil is when the engine is cool before it has been started for the day. If it has already been run, allow the oil to drain back down to the sump for at least 10 minutes before checking. If the oil level is at or below the “add” mark on the dipstick, add oil to bring the oil level to the “full” mark. **DO NOT OVERFILL.** If the oil level is between the “full” and “add” marks, no additional oil is required.

1. Park the machine on a level surface. Unlock the engine cover latches.
2. Open the engine cover.
3. Remove the dipstick, wipe it clean, install the dipstick into the tube, and pull it out again. The oil level should be up to the Full mark (Figure 8).

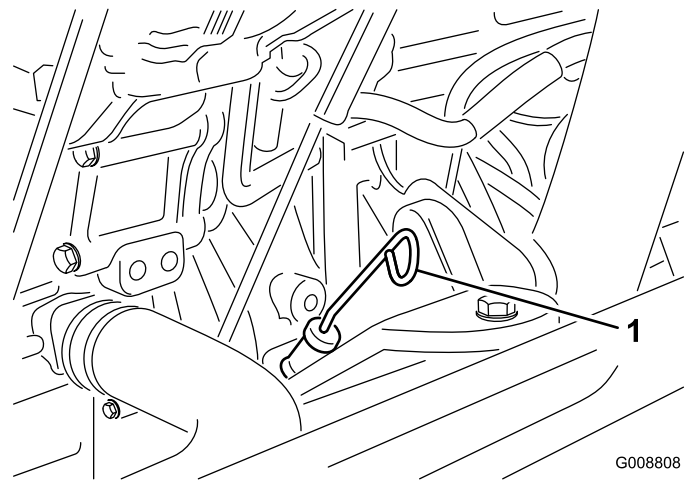

Figure 8

1. Dipstick

4. If the oil is below the Full mark, remove the fill cap (Figure 9) and add oil until the level reaches the Full mark. **Do not overfill.**

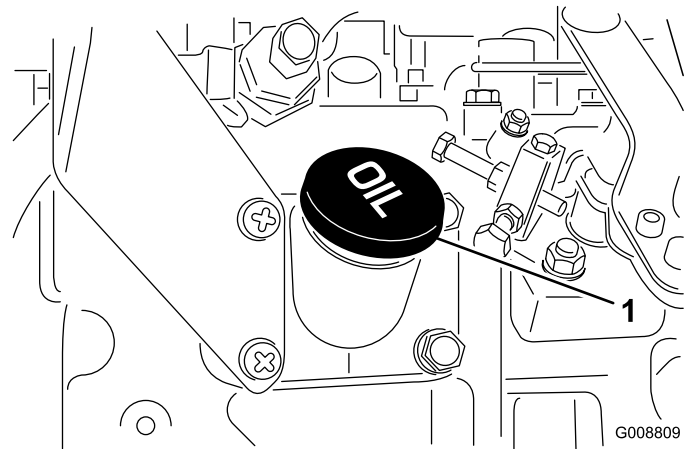

Figure 9

1. Oil fill cap

5. Install the oil fill cap and dipstick.
6. Close the engine cover and secure it with the latches.

Checking the Cooling System

Service Interval: Before each use or daily

Check level of coolant at the beginning of each day. Capacity of system is 13 qts. (12.3 l).

1. Carefully remove the radiator cap and expansion tank cap (Figure 10).

⚠ CAUTION

If the engine has been running, the pressurized, hot coolant can escape and cause burns.

- Do not open the radiator cap when the engine is running.
 - Use a rag when opening the radiator cap, and open the cap slowly to allow steam to escape.
2. Check the coolant level in the radiator. The radiator should be filled to the top of the filler neck and the expansion tank filled to the Full mark.

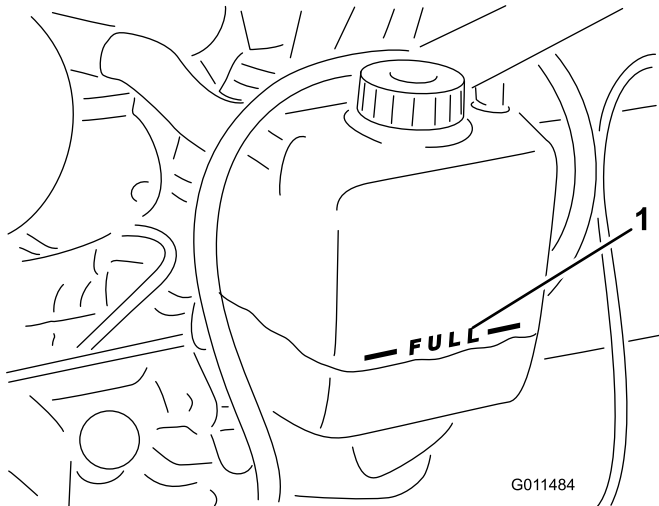

Figure 10

1. Expansion tank

-
3. If the coolant is low, add a 50/50 mixture of water and ethylene glycol anti-freeze. **Do not use water only or alcohol/methanol base coolants.**
4. Install the radiator cap and expansion tank cap.

Adding Fuel

Use only clean, fresh diesel fuel or biodiesel fuels with low (<500 ppm) or ultra low (<15 ppm) sulfur content. The minimum cetane rating should be 40. Purchase fuel in quantities that can be used within 180 days to ensure fuel freshness.

Fuel tank capacity: 19 US gallons (72 l)

Use summer grade diesel fuel (No. 2-D) at temperatures above 20° F (-7° C) and winter grade (No. 1-D or No. 1-D/2-D blend) below that temperature. Use of winter grade fuel at lower temperatures provides lower flash point and cold flow characteristics which will ease starting and reduce fuel filter plugging.

Use of summer grade fuel above 20° F (-7° C) will contribute toward longer fuel pump life and increased power compared to winter grade fuel.

Important: Do not use kerosene or gasoline instead of diesel fuel. Failure to observe this caution will damage the engine.

⚠ WARNING

Fuel is harmful or fatal if swallowed. Long-term exposure to vapors can cause serious injury and illness.

- Avoid prolonged breathing of vapors.
- Keep face away from nozzle and gas tank or conditioner opening.
- Keep fuel away from eyes and skin.

Biodiesel Ready

This machine can also use a biodiesel blended fuel of up to B20 (20% biodiesel, 80% petrodiesel). The petrodiesel portion should be low or ultra low sulfur. Observe the following precautions:

- The biodiesel portion of the fuel must meet specification ASTM D6751 or EN14214.
- The blended fuel composition should meet ASTM D975 or EN590.
- Painted surfaces may be damaged by biodiesel blends.
- Use B5 (biodiesel content of 5%) or lesser blends in cold weather.
- Monitor seals, hoses, gaskets in contact with fuel as they may be degraded over time.
- Fuel filter plugging may be expected for a time after converting to biodiesel blends.
- Contact your distributor if you wish for more information on biodiesel.

⚠ DANGER

In certain conditions, fuel is extremely flammable and highly explosive. A fire or explosion from fuel can burn you and others and can damage property.

- Fill the fuel tank outdoors, in an open area, when the engine is cold. Wipe up any fuel that spills.
- Never fill the fuel tank inside an enclosed trailer.
- Never smoke when handling fuel, and stay away from an open flame or where fuel fumes may be ignited by a spark.
- Store fuel in an approved container and keep it out of the reach of children. Never buy more than a 30-day supply of fuel.
- Do not operate without entire exhaust system in place and in proper working condition.

▲ DANGER

In certain conditions during fueling, static electricity can be released causing a spark which can ignite the fuel vapors. A fire or explosion from fuel can burn you and others and can damage property.

- Always place fuel containers on the ground away from your vehicle before filling.
- Do not fill fuel containers inside a vehicle or on a truck or trailer bed because interior carpets or plastic truck bed liners may insulate the container and slow the loss of any static charge.
- When practical, remove equipment from the truck or trailer and refuel the equipment with its wheels on the ground.
- If this is not possible, then refuel such equipment on a truck or trailer from a portable container, rather than from a fuel dispenser nozzle.
- If a fuel dispenser nozzle must be used, keep the nozzle in contact with the rim of the fuel tank or container opening at all times until fueling is complete.

1. Park the machine on a level surface.
2. Using a clean rag, clean area around fuel tank cap.
3. Remove cap from the fuel tank (Figure 11).

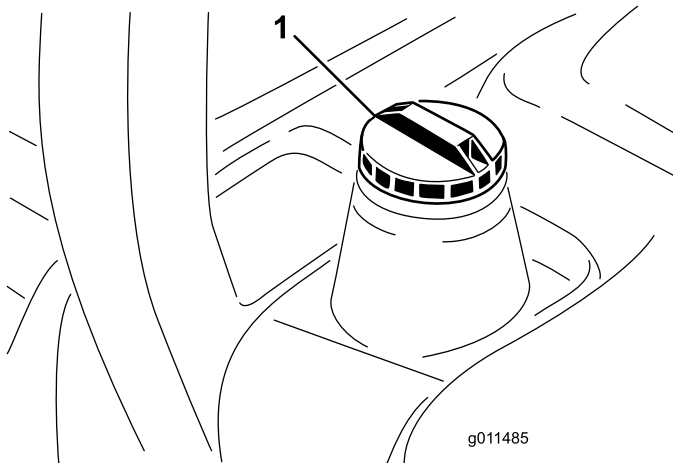

Figure 11

1. Fuel tank cap

4. Fill the tank until the level is to the bottom of the filler neck with diesel fuel.
5. Install fuel tank cap tightly after filling tank.

Note: If possible, fill the fuel tank after each use. This will minimize possible buildup of condensation inside the fuel tank.

Checking the Hydraulic Fluid

Service Interval: Before each use or daily

The machine's reservoir is filled at the factory with approximately 8 U.S. gallons (30.2 l) of high quality hydraulic fluid. **Check the level of the hydraulic fluid before the engine is first started and daily thereafter.** The recommended replacement fluid is:

Toro Premium All Season Hydraulic Fluid (Available in 5 gallon pails or 55 gallon drums. See parts catalog or Toro distributor for part numbers.)

Alternate fluids: If the Toro fluid is not available, other fluids may be used provided they meet all the following material properties and industry specifications. We do not recommend the use of synthetic fluid. Consult with your lubricant distributor to identify a satisfactory product.

Note: Toro will not assume responsibility for damage caused by improper substitutions, so use only products from reputable manufacturers who will stand behind their recommendation.

High Viscosity Index/Low Pour Point Anti-wear Hydraulic Fluid, ISO VG 46

Material Properties:

Viscosity, ASTM D445 St @ 40° C 44 to 48

St @ 100° C 7.9 to 8.5

Viscosity Index ASTM D2270 140 to 160

Pour Point, ASTM D97 -34° F to -49° F

Industry Specifications:

Vickers I-286-S (Quality Level), Vickers M-2950-S (Quality Level), Denison HF-0

Note: Many hydraulic fluids are almost colorless, making it difficult to spot leaks. A red dye additive for the hydraulic system oil is available in 2/3 oz (20 ml) bottles. One bottle is sufficient for 4-6 gallons (15-22 l) of hydraulic oil. Order part no. 44-2500 from your authorized Toro distributor.

1. Position the machine on a level surface, lower the cutting units, stop the engine, and remove the key.
2. Unlatch the seat, raise it, and engage the prop rod.
3. Clean the area around the filler neck and cap of the hydraulic tank (Figure 12). Remove the cap from the filler neck.

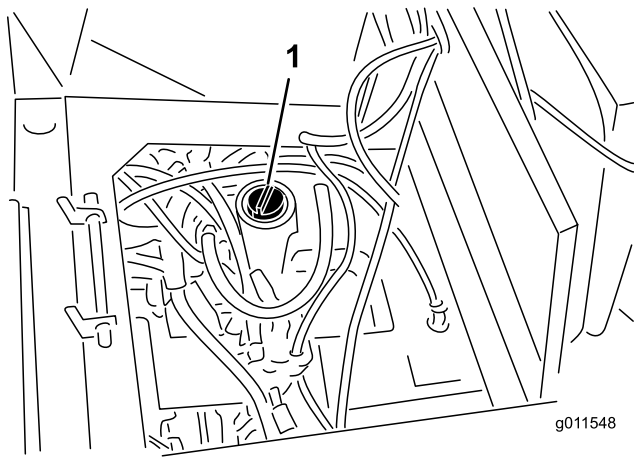

Figure 12

1. Hydraulic tank cap

4. Remove the dipstick from the filler neck and wipe it with a clean rag. Insert the dipstick into the filler neck; then remove it and check the fluid level. The fluid level should be between the two marks on the dipstick.
5. If the level is low, add the appropriate fluid to raise the level to the upper mark.
6. Install the dipstick and cap onto the filler neck.

Checking the Planetary Gear Drive Oil

Service Interval: Every 400 hours

Check the oil level after every 400 hours of operation or if external leakage is noted. Use high quality SAE 85W-140 gear lube as a replacement.

The capacity of the system is approximately 16 oz (0.5 l).

1. With the machine on a level surface, position the wheel so that the check/drain plug (Figure 13) is at either the 3 or 9 o'clock position.

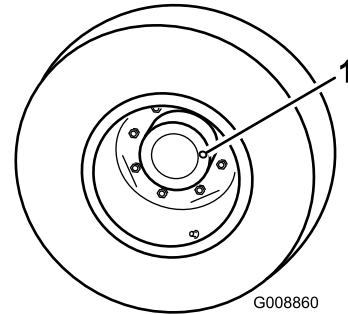

Figure 13

1. Check/drain plug

2. Add gear oil to the hole in the planetary, if necessary, to bring the oil up to the proper level. Install the plug.
3. Repeat the procedure on the opposite gear assembly.

Checking the Rear Axle Lubricant

Service Interval: Every 400 hours

The rear axle is filled with SAE 85W-140 gear lube. Check the oil level before the engine is first started and every 400 hours thereafter. The capacity is 80 oz (2.4 l). Visually inspect for leaks daily.

1. Position the machine on a level surface.
2. Remove a check plug from one end of the axle (Figure 14) and make sure that the lubricant is up to the bottom of the hole. If the level is low, remove the fill plug (Figure 14) and add enough lubricant to bring the level up to the bottom of the check plug holes.

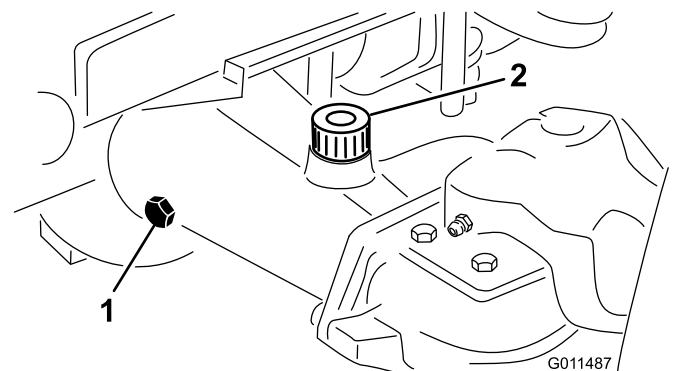

Figure 14

1. Check plug

2. Fill plug

Checking the Rear Axle Gear Box Lubricant

Service Interval: Every 400 hours

The gear box is filled with SAE 85W-140 gear lube. Check the oil level before the engine is first started and every 400 hours thereafter. The capacity is 16 oz (0.5 l). Visually inspect for leaks daily.

1. Position the machine on a level surface.
2. Remove the check/fill plug from the left side of the gear box (Figure 15) and make sure that lubricant is up to the bottom of the hole. If the level is low, add enough lubricant to bring the level up to the bottom of the hole.

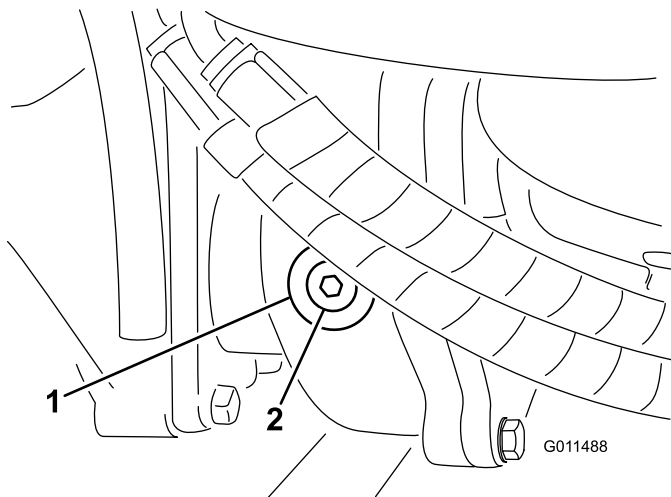

Figure 15

1. Gear box
2. Check/fill plug

Checking the Tire Pressure

Service Interval: Before each use or daily

The tires are over-inflated for shipping. Therefore, release some of the air to reduce the pressure. The correct air pressure in the front and rear tires is 25-30 psi (172-207 kPa).

Important: Maintain even pressure in all tires to ensure a good quality-of-cut and proper machine performance. *Do not under-inflate.*

Checking the Torque of the Wheel Nuts or Bolts

Service Interval: After the first 10 hours

Every 200 hours

⚠ WARNING

Failure to maintain proper torque of the wheel nuts could result in failure or loss of wheel and may result in personal injury.

Torque the front wheel nuts and rear bolts to 85 to 100 ft-lb (115 to 136 N·m) after 1-4 hours of operation and again after 10 hours of operation. Torque every 200 hours thereafter.

Adjusting the Height-of-Cut

Front Cutting Unit

The height-of-cut is adjustable from 1 to 5 inches (25 to 127 mm) in 1/2 inch (13 mm) increments. To adjust the height-of-cut on the front cutting unit, position the castor wheel axles in the upper or lower holes of the castor forks, add or remove an equal number of spacers from the castor forks, and secure the rear chain to the desired hole.

1. Start the engine and raise the cutting units so that the height-of-cut can be changed. Stop the engine and remove the key after the cutting unit is raised.
2. Position the castor wheel axles in the same holes in all castor forks. Refer to the following chart to determine the correct holes for the setting.

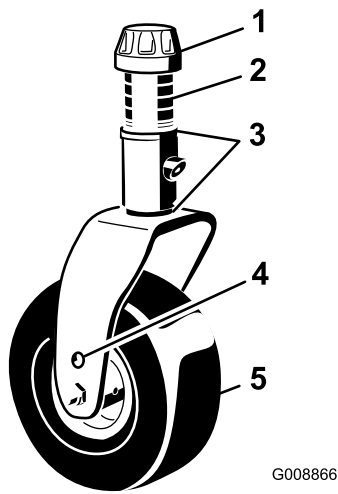

Figure 16

1. Tensioning cap
2. Spacers
3. Shims
4. Top axle mounting hole
5. Castor wheel

Note: When operating in 2-1/2 inch (64 mm) height of cut or higher, the axle bolt must be installed in the lower castor fork hole to prevent grass buildup between the wheel and the fork. When operating in height of cuts lower than 2-1/2 inches (64 mm) and grass buildup is detected, reverse the machines direction to pull any clippings away from the wheel/fork area.

3. Remove the tensioning cap from the spindle shaft (Figure 16) and slide the spindle out of the castor arm. Put the 2 shims (1/8 inch [3 mm]) onto the spindle shaft as they were originally installed. These shims are required to achieve a level across the entire width of the cutting units. Slide the appropriate number of 1/2 inch spacers (refer to the chart below) onto the spindle shaft to get the desired height-of-cut; then slide the washer onto the shaft.

Refer to the following chart to determine the combinations of spacers for the setting:

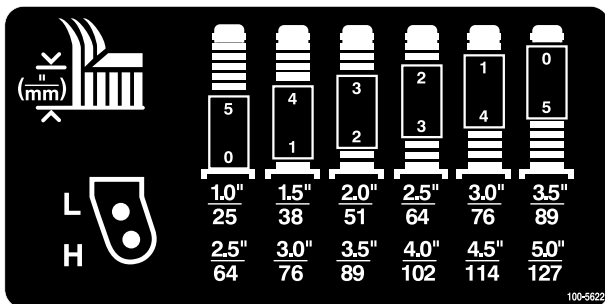

Figure 17

4. Push the castor spindle through the front castor arm. Install the shims (as they were originally installed) and the remaining spacers onto the spindle shaft. Install the tensioning cap to secure the assembly.

5. Remove the hairpin cotter and clevis pin securing the height-of-cut chains to the rear of the cutting unit (Figure 18).

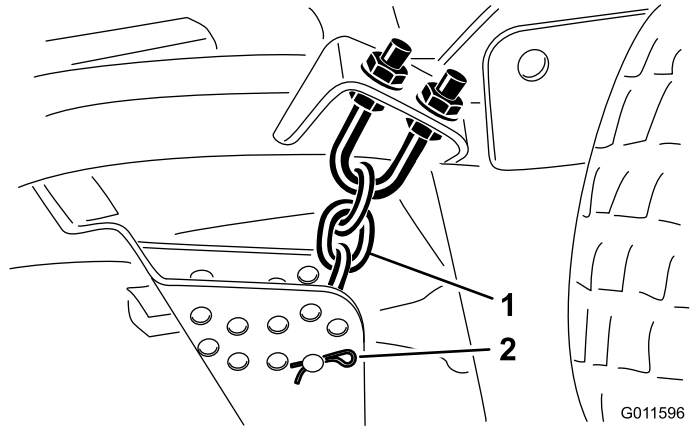

Figure 18

1. Height-of-cut chain
2. Clevis pin & hair pin cotter

6. Mount the height-of-cut chains to the desired height-of-cut hole (Figure 19) with the clevis pin and hairpin cotter.

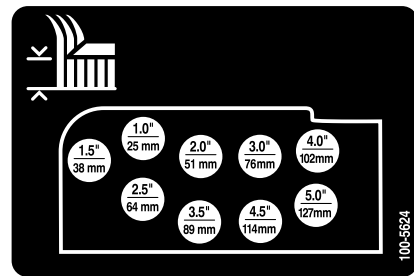

Figure 19

Note: When using 1 inch (25 mm), 1-1/2 inch (38 mm), or occasionally 2 inch (51 mm) height-of-cut, move the skids and gage wheels to the highest position.

Side Cutting Units

To adjust the height-of-cut on the side cutting units, add or remove an equal number of spacers from the castor forks, position the castor wheel axles in the high or low height-of-cut holes in the castor forks, and secure the pivot arms to the selected height-of-cut bracket holes.

1. Position the castor wheel axles in the same holes in all of the castor forks (Figure 20 and Figure 22). Refer to the following chart to determine the correct hole for the setting.
2. Remove the tensioning cap from the spindle shaft (Figure 20) and slide the spindle out of castor arm. Put the two shims (1/8 inch [3 mm]) onto spindle shaft as they were originally installed. These shims are required to achieve a level across the entire width of the cutting units. Slide the appropriate number of 1/2 inch spacers onto the spindle shaft to get the desired height-of-cut; then slide the washer onto the shaft.

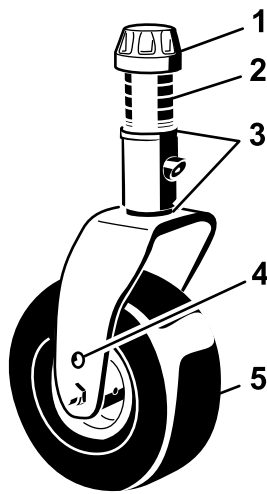

G008866

Figure 20

1. Tensioning cap
2. Spacers
3. Shims
4. To axle mounting hole
5. Castor wheel

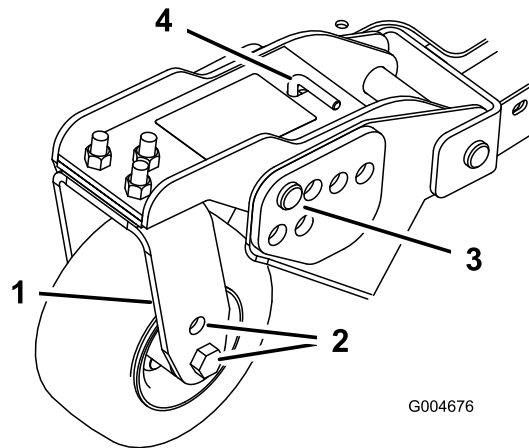

G004676

Figure 22

1. Castor pivot arm
2. Axle mounting holes
3. Clevis pin and hair pin cotter
4. Tension rod

Refer to the following chart to determine the combinations of spacers for the setting.

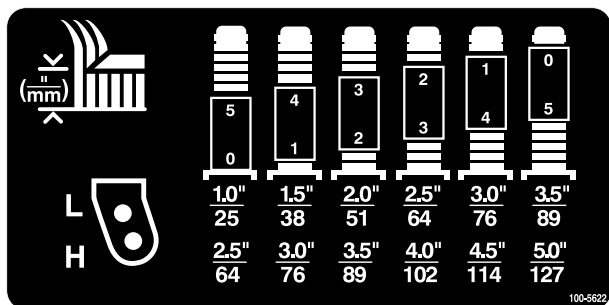

Figure 21

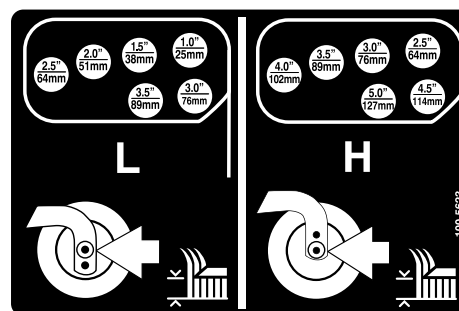

Figure 23

3. Push the castor spindle through the castor arm. Install the shims (as originally installed) and the remaining spacers onto the spindle shaft. Install the tensioning cap to secure the assembly.
4. Remove the hairpin cotter and clevis pins from the castor pivot arms (Figure 22).
5. Rotate tension rod to raise or lower pivot arm until holes are aligned with selected height-of-cut bracket holes in the cutting unit frame (Figure 22 and Figure 23).
6. Insert the clevis pins and install the hairpin cotters.
7. Rotate tension rod counterclockwise (finger tight) to put tension on adjustment.

8. Remove the hairpin cotters and clevis pins securing the damper links to the cutting unit brackets (Figure 24). Align the damper link holes with the selected height-of-cut bracket holes in the cutting unit frame (Figure 25), insert the clevis pins, and install the hairpin cotters.

Important: The damper link length should never be adjusted. The length between the hole centers should be 5-3/8 inch (13.7 cm).

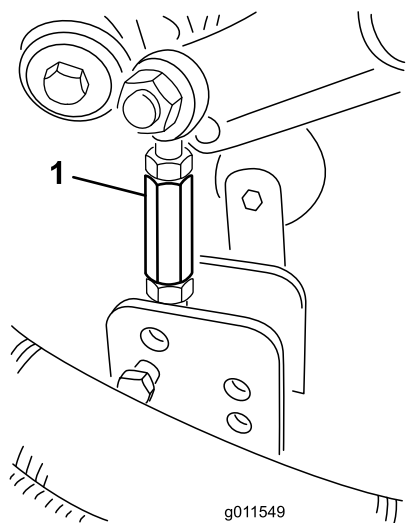

Figure 24

1. Damper link

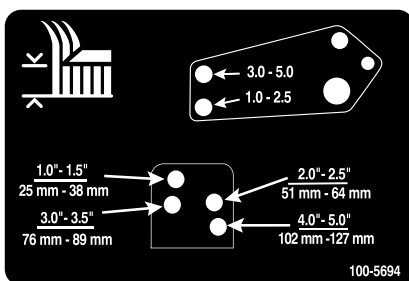

Figure 25

Adjusting the Skids

The skids should be mounted in the lower position when operating at heights of cut greater than 2-1/2 inches (64 mm) and in the higher position when operating at heights of cut lower than 2-1/2 inches (64 mm).

Note: When the skids become worn, you can switch the skid to the opposite sides of the mower, flipping them over. This will allow you to use the skids longer before replacing them.

1. Loosen the screw at the front of each skid (Figure 26).

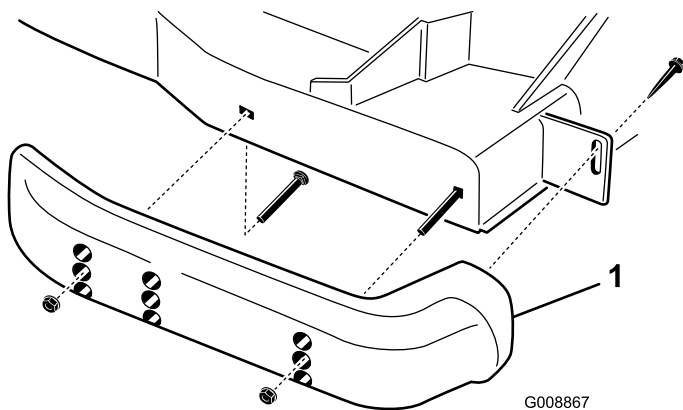

Figure 26

2. Remove the flange-head bolts and nuts from each skid (Figure 26).
3. Move each skid to the desired position and secure them with the flange-head bolts and nuts.

Note: Only use the top or center sets of holes to adjust the skids. The bottom holes are used when switching sides at which time they become the top holes on the other side of the mower.

4. Torque the screw at the front of each skid to 80 to 100 in-lb (9 to 11 N·m).

Adjusting the Cutting Unit Rollers

The cutting unit rollers should be mounted in the lower position when operating in height of cuts greater than 2-1/2 inches (64 mm) and in the higher position when operating in height of cuts lower than 2-1/2 inches (64 mm).

1. Remove the bolt and nut securing the gage wheel to the cutting unit brackets (Figure 27).

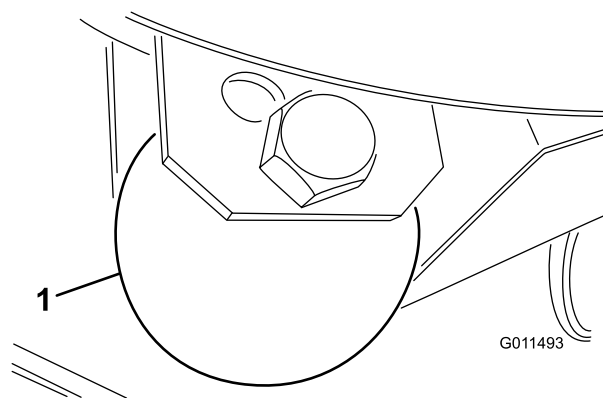

Figure 27

1. Gage wheel
2. Align the roller and spacer with the top holes in the brackets and secure them with the bolt and nut.

Correcting Mismatch Between Cutting Units

Due to differences in grass conditions and the counterbalance setting of the traction unit, it is advised that a sample area of grass be cut and the appearance checked before formal cutting is started.

1. Set all cutting units to the desired height of cut; refer to Adjusting the Height of Cut.
2. Check and adjust front and rear tractor tire pressure to 25-30 psi (172-207 kPa).
3. Check and adjust all castor tire pressures to 50 psi (345 kPa).
4. Check charge and counterbalance pressures with engine at high idle using test ports defined in Hydraulic

Systems Test Ports. Adjust counterbalance setting to be 220 psi (1517 kPa) higher than charge pressure reading.

5. Check for bent blades; refer to Checking for a Bent Blade.
6. Cut grass in a test area to determine if all cutting units are cutting at the same height.
7. If cutting unit adjustments are still needed, find a flat surface using a 6 foot (2 m) or longer straight edge.
8. To ease measuring blade plane, raise the height of cut to the highest position; refer to Adjusting the Height of Cut.
9. Lower cutting units onto the flat surface. Remove the covers from the top of the cutting units.
10. Loosen the flange nut, securing the idler pulley, to release the belt tension on each cutting unit.

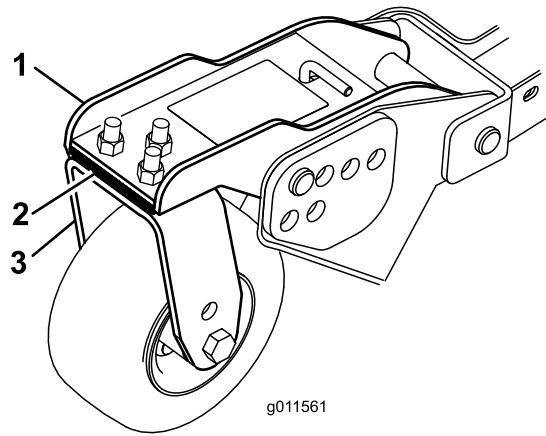

Figure 29

- | | |
|---------------------|----------------------|
| 1. Front castor arm | 3. Front castor fork |
| 2. Shims | |

Front Cutting Unit Setup

Rotate blade on each spindle until the ends face forward and backward. Measure from the floor to the front tip of the cutting edge. Adjust 1/8 inch shims on front castor fork(s) to match height of cut to decal (Figure 28); refer to Adjusting the Cutting Unit Pitch.

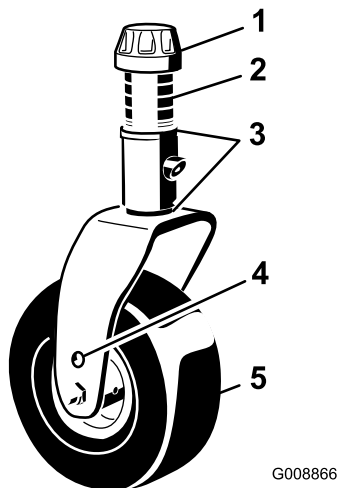

Figure 28

- | | |
|-------------------|---------------------------|
| 1. Tensioning cap | 4. Top axle mounting hole |
| 2. Spacers | 5. Castor wheel |
| 3. Shims | |

Side Cutting Unit Setup

Rotate blade of each spindle until the ends face forward and backward. Measure from the floor to the front tip of the cutting edge. Adjust 1/8 inch shims on front castor arm(s) to match height of cut to decal (Figure 29). For the outside blade spindle only, refer to Adjusting the Cutting Unit Pitch.

Matching Height Of Cut Between Cutting Units

1. Position blade side to side on outside spindle of both side cutting units. Measure from the floor to the tip of the cutting edge on both units and compare. These numbers should be within 1/8 inch (3 mm) of each other. Make no adjustment at this time.
2. Position blade side to side on inside spindle of side cutting unit and corresponding outside spindle of front cutting unit. Measure from the floor to the tip of the cutting edge on inside edge of side cutting unit to corresponding outside edge of front cutting unit and compare. The side cutting unit measurement should be approximately 3/8 inch less than the front cutting unit measurement to be correct. When proper machine counterbalance is applied to the side cutting units the inside edge will lift up approximately 3/8 inch (10 mm).

Note: All three side cutting units castor wheels should remain on the ground with counterbalance applied.

Note: If adjustments need to be made to match the cut between the front and side cutting units, make the adjustments to the **side cutting units only**.

3. If the inside edge of the side cutting unit is too high relative to the outside edge of the front cutting unit, remove one 1/8 inch shim from the bottom of the front inside castor arm on the side cutting unit (Figure 29). Recheck measurement between outside edges of both side cutting units and inside edge of side cutting unit to outside edge of front cutting unit.
4. If inside edge is still too high, remove an additional 1/8 inch shim from bottom of front inside castor arm of the side cutting unit **and** one 1/8 inch shim from the front outside castor arm of the side cutting unit.
5. If the inside edge of the side cutting unit is too low relative to the outside edge of the front cutting unit, add one 1/8 inch shim to the bottom of the front inside castor arm on the side cutting unit. Check measurement between outside edges of both side

cutting units and inside edge of side cutting unit to outside edge of front cutting unit.

6. If inside edge is still too low, add an additional 1/8 inch shim to the bottom of front inside castor arm of the side cutting unit **and** add one 1/8 inch shim to the front outside castor arm of the side cutting unit.
7. Once cutting height matches at the edges of front and side cutting units, verify that side cutting unit pitch is still 1/4 inch (6 mm). Adjust as necessary.

Adjusting the Mirrors

Model 30446 only

Rear View Mirror

While sitting in the seat, adjust the rear view mirror (Figure 30) to attain the best view out the rear window. Pull the lever rearward to tilt the mirror to reduce the brightness and glare of light.

Side View Mirrors

While sitting in the seat, have a helper adjust the side view mirrors (Figure 30) to attain the best view around the side of the machine.

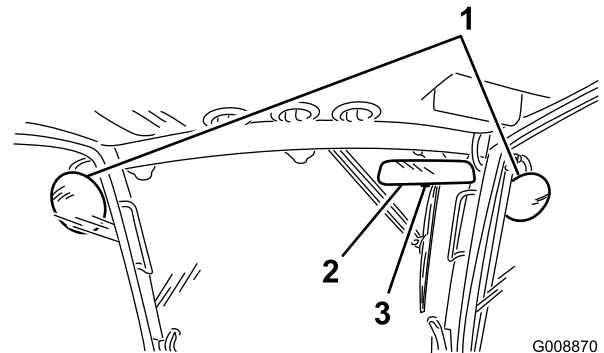

Figure 30

G008870

1. Side view mirrors
2. Rear view mirror
3. Lever

Aiming the Headlights

1. Loosen the mounting nuts and position each headlight so that it points straight ahead. Tighten the mounting nut just enough to hold the headlight in position.
2. Place a flat piece of sheet metal over the face of the headlight.
3. Mount a magnetic protractor onto the plate. While holding the assembly in place, carefully tilt the headlight downward 3 degrees, then tighten the nut.
4. Repeat the procedure on the other headlight.

Starting and Stopping the Engine

Important: The fuel system will automatically bleed itself when any of the following situations occur:

- Initial start up of a new machine.
 - The engine has ceased running due to lack of fuel.
 - Maintenance has been performed upon the fuel system components.
1. Ensure that the parking brake is set. Remove your foot from the traction pedal and ensure that it is in neutral.

2. Move the throttle control to the mid-idle position.
3. Turn the ignition key to the Run position. The glow indicator will light.
4. When the glow indicator dims, turn the ignition key to the Start position. Release the key immediately when the engine starts and allow it to return to the Run position. Allow engine to warm up at mid speed (without load), then move the throttle control to the desired position.

Important: Do not run the starter motor more than 15 seconds at a time or premature starter failure may result. If the engine fails to start after 15 seconds, turn the key to the Off position, recheck the controls and procedures, wait 15 additional seconds, and repeat the starting procedure.

When the temperature is less than 20°F (-75C), preheat glow plugs twice prior to initial cranking attempt. The starter motor can be run for 30 seconds on then 60 seconds off for 2 attempts.

5. To stop the engine, move the throttle control backward to the Slow position, move the PTO lever to the Off position, set the parking brake, and rotate the ignition key to Off. Remove the key from the switch to prevent accidental starting.

Important: Allow engine to idle for 5 minutes before shutting it off after a full load operation. Failure to do so may lead to turbo-charger trouble.

Engine Cooling Fan Operation

The engine cooling fan switch has two positions for controlling the operation of the fan. The two positions are R and Auto. The fan has the ability to reverse to blow debris off of the rear screen. Under normal operating conditions, the switch will be in the Auto position. In Auto, the fan speed will be controlled by the coolant or hydraulic oil temperature and will automatically reverse to blow debris off of the rear screen. A reverse cycle is automatically initiated when either the coolant or hydraulic temperature reaches a certain point. By pressing the fan switch forward into the R position, the fan will complete a manually initiated reverse cycle. It is recommended to reverse the fan when the rear screen is clogged or prior to entering the shop or the storage area.

Checking the Interlock Switches

⚠ CAUTION

If safety interlock switches are disconnected or damaged the machine could operate unexpectedly causing personal injury.

- Do not tamper with the interlock switches.
- Check the operation of the interlock switches daily and replace any damaged switches before operating the machine.

The machine has interlock switches in the electrical system. These switches are designed to stop the engine when the operator gets off of the seat when the traction pedal is depressed. However, the operator may get off of the seat while the engine is running and the traction pedal is in neutral. Although the engine will continue to run if the PTO lever is disengaged and the traction pedal is released, it is strongly recommended that the engine be stopped before rising from the seat.

To check the operation of the interlock switches, perform the following procedure:

1. Drive the machine slowly to a large, relatively open area. Lower the cutting unit, stop the engine, and apply the parking brake.
2. Sit on the seat and depress the traction pedal. Try to start the engine. The engine should not crank. If the engine cranks, there is a malfunction in the interlock system that should be corrected before beginning operation.
3. Sit on the seat and start the engine. Rise from the seat and move the PTO lever to On. The PTO should not engage. If the PTO engages, there is a malfunction in the interlock system that should be corrected before beginning operation.
4. Sit on the seat, engage the parking brake and start the engine. Move the traction pedal out of the neutral position. The engine should kill. If the engine does not kill, there is a malfunction in the interlock system that should be corrected before beginning operation.

Pushing or Towing the Machine

In an emergency, the machine can be moved forward by actuating the bypass valve in the variable displacement hydraulic pump and pushing or towing the machine. **Do not push or tow the machine for more than 1/4 mile (0.4 km).**

Important: Do not push or tow the machine faster than 2-3 MPH (3-4.8 km/h) because internal transmission damage may occur. The bypass valve must be open whenever the machine is pushed or towed.

1. Raise the seat and remove the battery cover. The bypass valve is located in front of the battery (Figure 31).
2. Rotate the valve 1/4 turn in either direction to open and allow oil to bypass internally. Because fluid is bypassed, the machine can be slowly moved without damaging the transmission. Note the position of the valve when opening or closing.
3. Close the bypass valve before starting the engine. However, do not exceed 5 to 8 ft-lb (7 to 11 N·m) torque to close the valve.

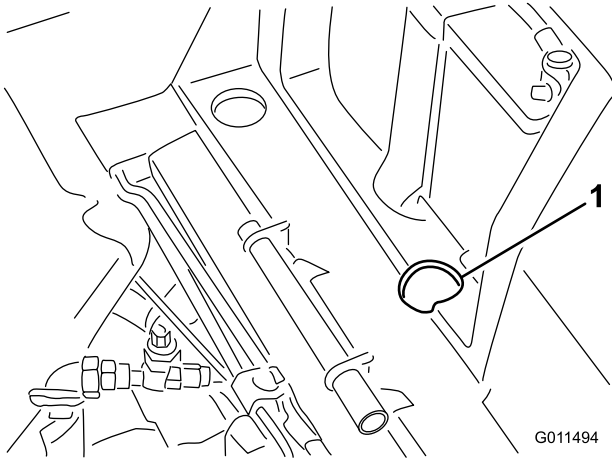

Figure 31

1. Bypass valve access hole

Important: If the machine must be pushed or towed in reverse, the check valve in the four-wheel drive manifold must also be bypassed. To bypass the check valve, connect a hose assembly (Hose Part No. 95-8843, Coupler Fitting No. 95-0985 [Qty. 2], and Hydraulic Fitting No. 340-77 [Qty. 2]) to the reverse traction pressure test port (Figure 32) and the reverse four-wheel drive pressure port (Figure 33).

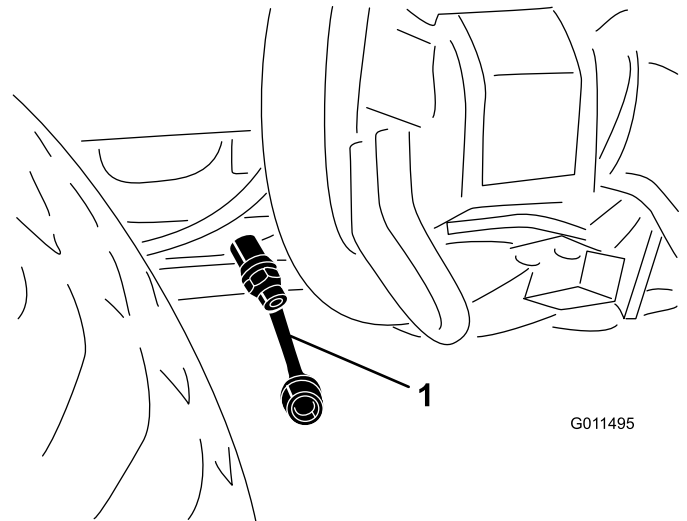

Figure 32

1. Reverse traction pressure test port

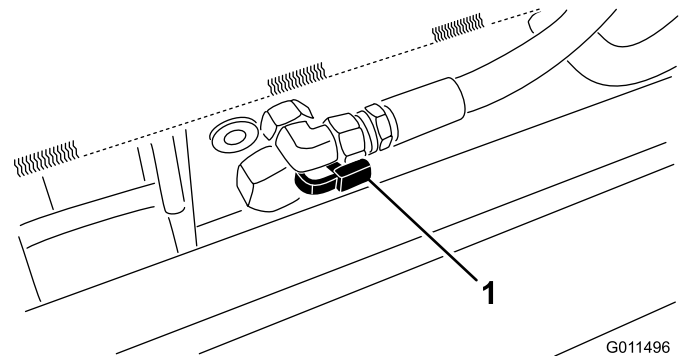

Figure 33

1. Reverse four-wheel drive pressure test port

Jacking Points

There are jacking points located at the front and rear of the machine.

- On the frame at the inside of each front drive tire
- At the center of the rear axle

Tie Downs

There are tie downs located at the front, rear and sides of the machine.

- On each side of the frame by the side cutting unit lift arms
- Front center of the operator's platform
- The rear bumper

Operating Characteristics

Practice driving the machine because it has a hydrostatic transmission and its characteristics are different than many turf maintenance machines. Some points to consider when operating the traction unit, cutting unit, or other implements are the transmission, engine speed, load on the cutting blades or other implement components, and the importance of the brakes.

To maintain enough power for the traction unit and implement while operating, regulate the traction pedal to keep the engine speed high and somewhat constant. A good rule to follow is to decrease the ground speed as the load on the implement increases, and increase the ground speed as the load decreases.

Therefore, allow the traction pedal to move backward as the engine speed decreases, and depress the pedal slowly as the speed increases. By comparison, when driving from one work area to another, with no load and cutting unit raised, have the throttle in the Fast position and depress the traction pedal slowly but fully to attain maximum ground speed.

The flow divider enhances traction drive performance in compromised operating conditions. The flow divider is for use in low speed range only. When approaching an area known to cause wheel spin, depress and hold flow divider switch until completely past the area. If a tire spins while climbing or maneuvering on slopes, depress switch and slowly drive out of area. If both a front and rear wheel spins, the steering brake can be feathered to transfer the torque from the spinning wheels to the opposite front wheel.

The brakes can be used to assist in turning the machine. However, use them carefully, especially on soft or wet grass because the turf may be torn accidentally. Another benefit of the brakes is to maintain traction. For example, in some slope conditions, the uphill wheel slips and loses traction. If this situation occurs, depress the uphill turn pedal gradually and intermittently until the uphill wheel stops slipping, thus, increasing traction on the downhill wheel.

Use extra care when operating the machine on slopes. Make sure that the seat latch is properly secured and the seat belt is buckled. Drive slowly and avoid sharp turns on slopes to prevent roll overs. For steering control, the cutting unit must be lowered when going downhill.

▲ WARNING

This cutting units are designed to drive objects into the ground where they lose energy quickly in grass areas. However, careless operation, combined with terrain angle, ricochets, or improperly positioned safety guard can lead to thrown object injuries.

- **When a person or pet appears suddenly in or near the mowing area, *stop mowing*.**
- **Do not resume mowing until the area is cleared.**

Before stopping the engine, disengage all controls and move the throttle to Slow. Moving the throttle to Slow reduces high engine speed, noise, and vibration. Turn the key to Off to stop the engine.

Before transporting the machine, raise the cutting units and secure the transport latches (Figure 34).

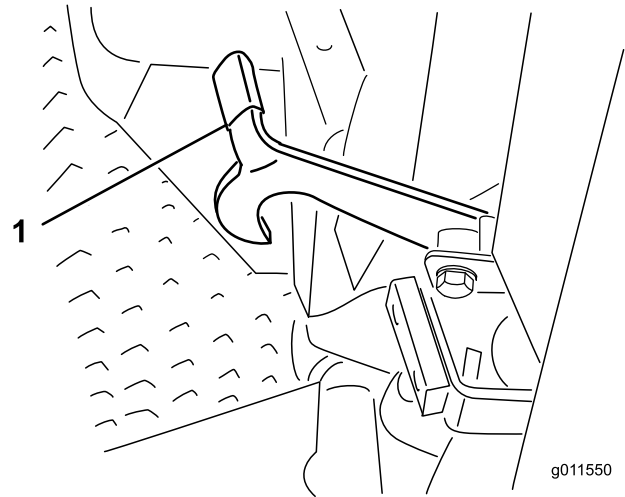

Figure 34

1. Transport latch (side cutting units)

Operating Tips

Mow When Grass is Dry

Mow either in the late morning to avoid the dew, which causes grass clumping, or in late afternoon to avoid the damage that can be caused by direct sunlight on the sensitive, freshly mowed grass.

Select the Proper Height-of-Cut Setting to Suit Conditions

Remove approximately 1 inch (25 mm) or no more than 1/3 of the grass blade when cutting. In exceptionally lush and dense grass, you may have to raise the height-of-cut to the next setting.

Mow at Proper Intervals

Under most normal conditions you will need to mow approximately every 4-5 days. But remember, grass grows at different rates at different times. This means that in order to maintain the same height-of-cut, which is a good practice, you will need to cut more frequently in early spring; as the grass growth rate slows in mid summer, cut only every 8-10 days. If you are unable to mow for an extended period due to weather conditions or other reasons, mow first with the height-of-cut at a high level; then mow again 2-3 days later with a lower height setting.

Transporting

Use the transport latches when transporting over long distances, rough terrain, or when trailering.

After Operating

To ensure optimum performance, clean the underside of the mower housing after each use. If residue is allowed to build up in the mower housing, cutting performance will decrease.

Cutting Unit Pitch

A blade pitch of 1/4 inch (6 mm) is recommended. A pitch larger than 1/4 inch (6 mm) will result in less power required, larger clippings, and a poorer quality of cut. A pitch less than 1/4 inch (6 mm) will result in more power required, smaller clippings and a better quality of cut.

Maximizing Air Conditioner Performance

- To limit solar heating, park the machine in a shaded area or leave the doors open in direct sun.
- Check to make sure the air conditioning condenser fins are clean.

- Operate the air conditioner blower at the mid speed setting.
- Verify continuous seal between the roof and the headliner. Correct as required.
- Measure the air temperature at the front center vent in the headliner (Typically stabilize at less than or equal to 50 degrees F.)
- Refer to the Service Manual for additional information

Maintenance

Note: Determine the left and right sides of the machine from the normal operating position.

Recommended Maintenance Schedule(s)

Maintenance Service Interval	Maintenance Procedure
After the first 10 hours	<ul style="list-style-type: none"> • Torque the wheel lug nuts. • Check the alternator belt tension. • Check the compressor belt tension. • Check the blade drive belt tension.
After the first 50 hours	<ul style="list-style-type: none"> • Change the engine oil and filter. • Check the engine speed (at idle and full throttle).
After the first 200 hours	<ul style="list-style-type: none"> • Change the front planetary gear oil. • Change the rear axle oil. • Change the hydraulic oil. • Change the hydraulic oil filters.
Before each use or daily	<ul style="list-style-type: none"> • Check the engine oil level. • Check the coolant level. • Check the hydraulic fluid level. • Check the tire pressure. • Check the air cleaner indicator • Check the interlock switch operation
Every 50 hours	<ul style="list-style-type: none"> • Lubricate all grease fittings. • Inspect the air cleaner. • Check the blade drive belt tension. • Clean the air conditioning screen. (Clean more frequently in extremely dusty or dirty conditions) • Remove all debris and chaff from the radiator and oil cooler.
Every 100 hours	<ul style="list-style-type: none"> • Inspect the cooling system hoses and clamps. • Check the alternator belt tension. • Check the compressor belt tension.
Every 150 hours	<ul style="list-style-type: none"> • Change the engine oil and filter.
Every 200 hours	<ul style="list-style-type: none"> • Torque the wheel lug nuts. • Service the spark arrestor muffler.
Every 250 hours	<ul style="list-style-type: none"> • Clean the cab air filters. (Replace them if they are torn or excessively dirty.) • Clean the air conditioning coil. (Clean more frequently in extremely dusty or dirty conditions)
Every 400 hours	<ul style="list-style-type: none"> • Check the planetary gear drive oil. • Check the rear axle lubricant. • Check the rear axle gear box lubricant. • Service the air filter (if the indicator shows red). • Inspect the fuel lines and connections. • Replace the fuel filter canister. • Check the engine speed (at idle and full throttle).

Maintenance Service Interval	Maintenance Procedure
Every 800 hours	<ul style="list-style-type: none"> • Drain and clean the fuel tank. • Change the front planetary gear oil. • Change the rear axle oil. • Check the rear wheel toe-in. • Inspect the blade drive belts. • Change the hydraulic oil. • Change the hydraulic oil filters. • Inspect the side cutting unit damper. • Inspect the cutting unit castor wheel assemblies. • Check and adjust the valve clearance.
Every 2 years	<ul style="list-style-type: none"> • Flush the cooling system and replace fluid. • Replace moving hoses.

⚠ CAUTION

If you leave the key in the ignition switch, someone could accidentally start the engine and seriously injure you or other bystanders.

Remove the key from the ignition before you do any maintenance.

Service Interval Chart

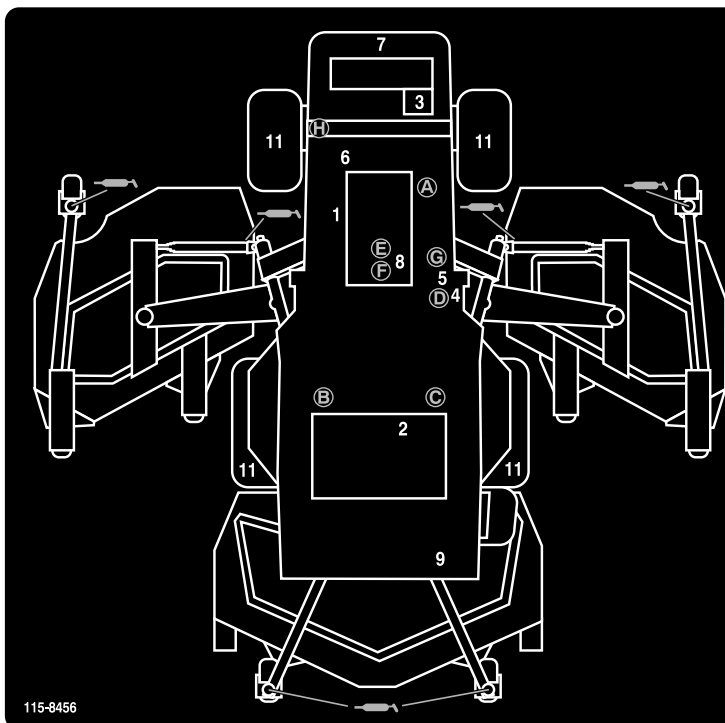

GROUNDMASTER 4000 QUICK REFERENCE AID

CHECK/SERVICE (DAILY)

1. ENGINE OIL LEVEL
2. HYDRAULIC FLUID LEVEL
3. ENGINE COOLANT LEVEL
4. FUEL - DIESEL ONLY
5. FUEL/WATER SEPARATOR
6. FAN BELT TENSION
7. RADIATOR SCREEN
8. AIR CLEANER
9. BRAKE FUNCTION
10. INTERLOCK SYSTEM
11. TIRE PRESSURE - 25 PSI/1.70 BAR
12. GREASE POINTS (6) →

SEE OPERATOR'S MANUAL FOR 50 HR INTERVAL GREASE POINTS.

SPECIFICATIONS/CHANGE INTERVALS

SEE OPERATOR'S MANUAL FOR INITIAL CHANGES.	FLUID TYPE	CAPACITY	CHANGE INTERVAL		FILTER PART NO.
			FLUID	FILTER	
ENGINE OIL	15W-40 CH-4, CI-4	10 QUARTS	150 HOURS	150 HOURS	104-5169 (A)
HYDRAULIC FLUID	ISO VG 46/68	8 GALLONS	800 HOURS	800 HOURS	75-1310 (B) 94-2621 (C)
HYDRAULIC BREATHER				800 HRS/YRLY	68-6150 (D)
PRIMARY AIR FILTER				SEE SERVICE INDICATOR	108-3814 (E)
SAFETY AIR FILTER				SEE OPERATOR'S MANUAL	108-3816 (F)
FUEL SYSTEM	> 32 F	NO. 2 DIESEL	19 GALLONS	800 HOURS DRAIN/FLUSH	400 HOURS/ YEARLY
	< 32 F	NO. 1 DIESEL			
REAR AXLE	85W-140	80 OUNCES	800 HOURS		110-9049 (G) WATER SEPARATOR
PLANETARY DRIVE	85W-140	16 OUNCES	800 HOURS		110-4812 (H) BREATHER
ENGINE COOLANT	50% WATER 50% ETHYL GLYCOL	13 QUARTS	DRAIN & FLUSH EVERY 2 YRS.		

Figure 35

Lubrication

Greasing the Bearings and Bushings

The machine has grease fittings that must be lubricated regularly with No. 2 General Purpose Lithium Base Grease. If the machine is operated under normal conditions, lubricate all bearings and bushings after every 50 hours of operation or immediately after every washing.

The grease fitting locations and quantities are:

Traction Unit

Service Interval: Every 50 hours

- Brake shaft pivot bearings (5) (Figure 36)
- Traction pedal pivot bushing (1) (Figure 37)
- Front and rear axle pivot bushings (2) (Figure 38)
- Steering cylinder ball joints (2) (Figure 39)
- Tie rod ball joints (2) (Figure 39)
- King pin bushings (2) (Figure 39).
The top fitting on the king pin should only be lubricated annually (2 pumps).

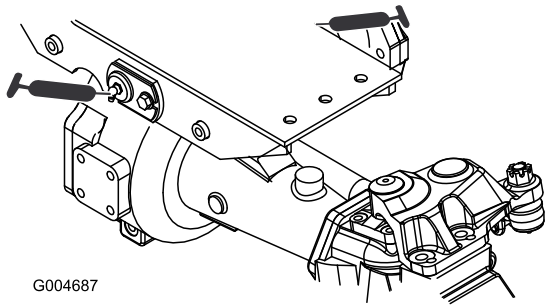

Figure 38

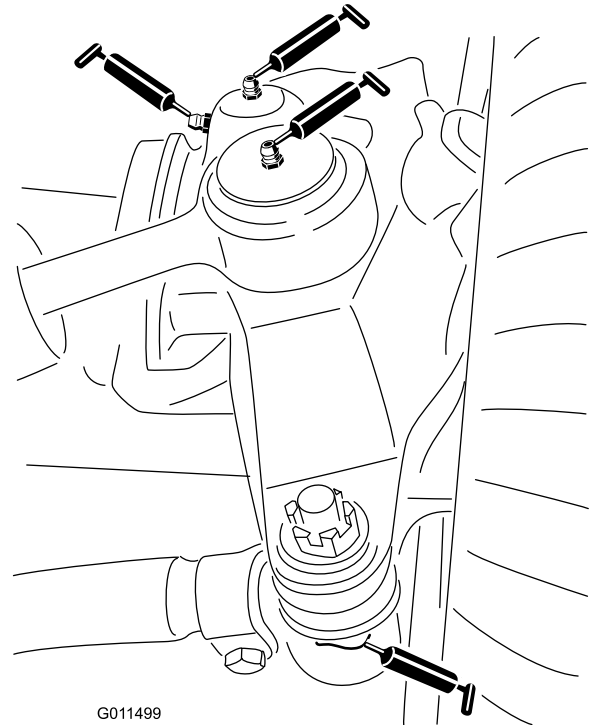

Figure 39

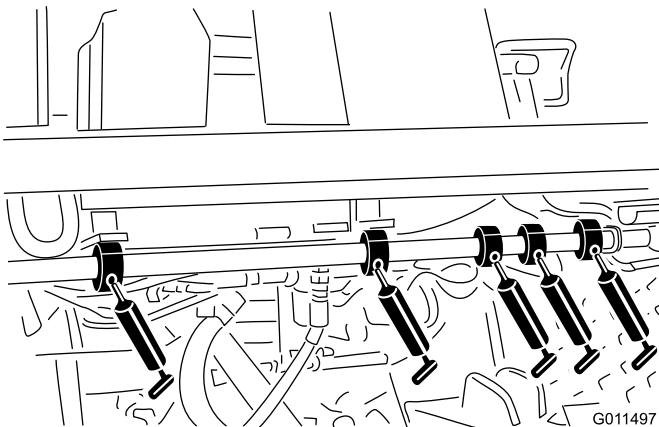

Figure 36

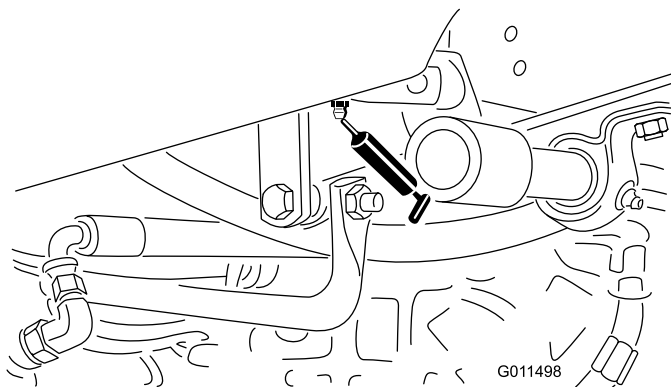

Figure 37

Front Cutting Unit

- Castor fork shaft bushings (2) (Figure 40)
- Spindle shaft bearings (3) (located under the pulley) (Figure 41)
- Idler arm pivot bushings (2) (Figure 41)

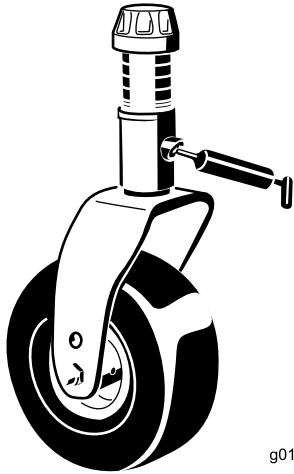

Figure 40

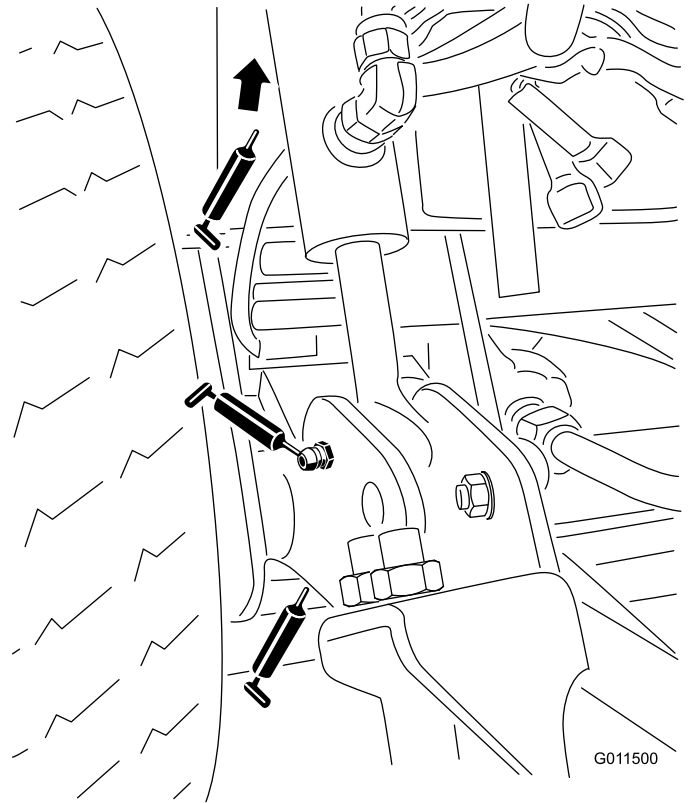

Figure 42

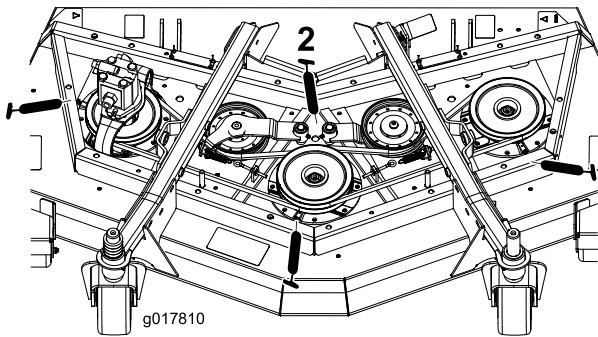

Figure 41

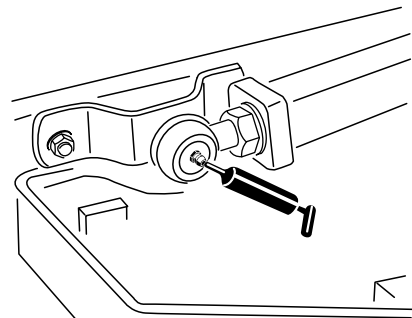

Figure 43

Front Lift Assemblies

- Lift arm bushings (2) (Figure 42)
- Lift cylinder bushings (4) (Figure 42)
- Lift arm ball joints (2) (Figure 43)

Side Cutting Units

- Castor fork shaft bushing (1) (Figure 44)
- Spindle shaft bearings (2 each) (located under the pulley)
- Idler arm pivot bushings (1) (located on the idler arm)

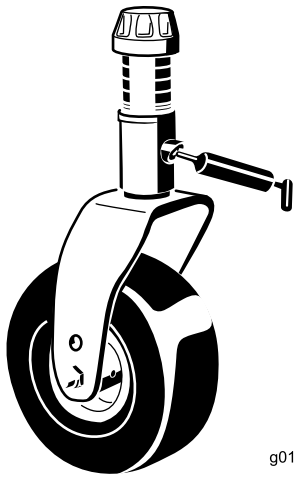

g011557

Figure 44

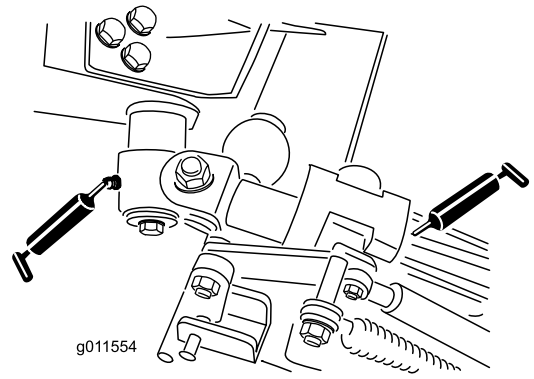

g011554

Figure 47

Side Lift Assemblies

- Main lift arm bushings (6) (Figure 45 and Figure 46)
- Bell crank pivot bushings (2) (Figure 47)
- Rear arm bushings (4) (Figure 47)
- Lift cylinder bushings (4) (Figure 48)

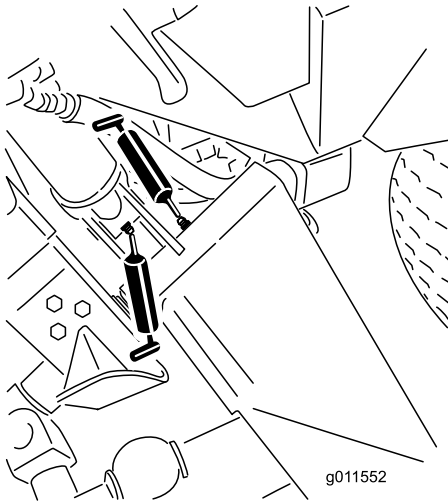

g011552

Figure 45

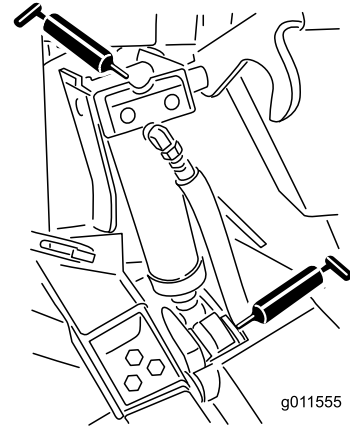

g011555

Figure 48

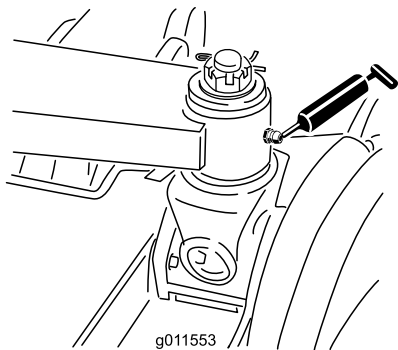

g011553

Figure 46

Engine Maintenance

Air Cleaner Maintenance

- Check the air cleaner body for damage which could cause an air leak. Replace if damaged. Check the whole intake system for leaks, damage or loose hose clamps.
- Service the air cleaner filter only when the service indicator requires it or every 400 hours (more frequently in extremely dusty or dirty conditions). Changing the air filter before it is necessary only increases the chance of dirt entering the engine when the filter is removed.
- Be sure the cover is seated correctly and seals with the air cleaner body.

Servicing the Air Cleaner

Service Interval: Before each use or daily

Every 50 hours

Every 400 hours

1. Pull the latch outward and rotate the air cleaner cover counterclockwise (Figure 49).
2. Remove the cover from the air cleaner body. Before removing the filter, use low pressure air (40 psi, clean and dry) to help remove large accumulations of debris packed between outside of primary filter and the canister. Avoid using high pressure air which could force dirt through the filter into the intake area. This cleaning process prevents debris from migrating into the intake when the primary filter is removed.

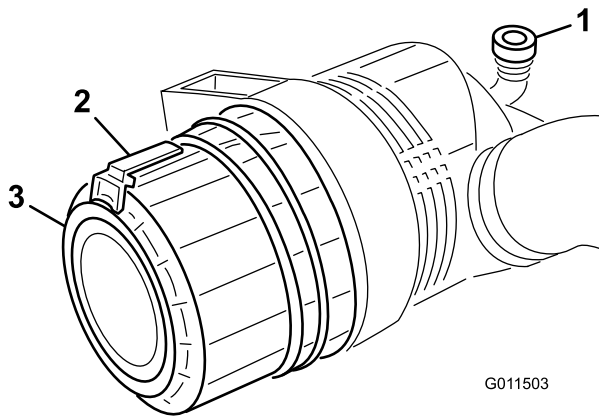

Figure 49

1. Air cleaner indicator
2. Air cleaner latch
3. Air cleaner cover

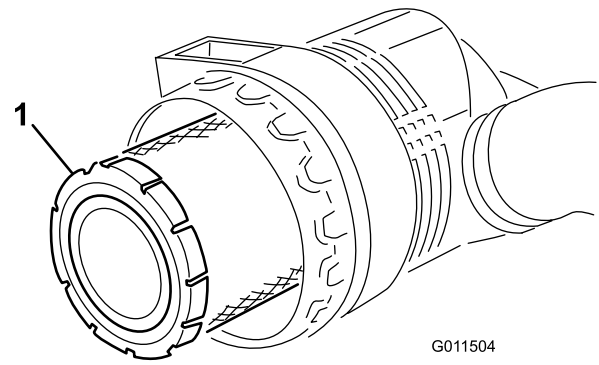

Figure 50

1. Air cleaner primary filter

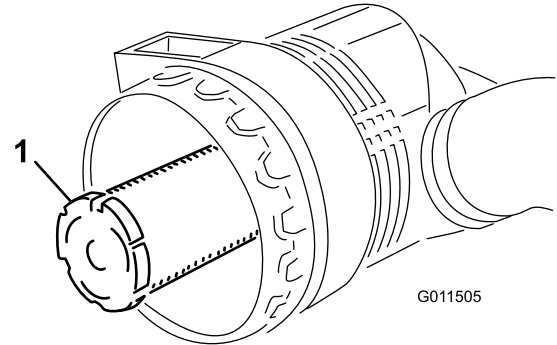

Figure 51

1. Air cleaner safety filter

Important: Never attempt to clean the safety filter (Figure 51). Replace the safety filter with a new one after every three primary filter services.

4. Replace the primary filter (Figure 50).
5. Insert the new filter by applying pressure to the outer rim of the element to seat it in the canister. Do not apply pressure to the flexible center of the filter.
6. Clean the dirt ejection port located in the removable cover. Remove the rubber outlet valve from the cover, clean the cavity and replace the outlet valve.
7. Install the cover orienting the rubber outlet valve (Figure 49) in a downward position - between approximately 5:00 to 7:00 when viewed from the end. Secure the latch.

3. Remove the primary filter (Figure 50). Cleaning of the used element is not recommended due to the possibility of damage to the filter media. Inspect the new filter for shipping damage, checking the sealing end of the filter and the body. Do not use a damaged element. **Do not** remove the safety filter (Figure 51).

Servicing the Engine Oil and Filter

Service Interval: After the first 50 hours

Every 150 hours

Change the oil and filter initially after the first 50 hours of operation; thereafter change the oil and filter every 150 hours.

1. Remove either drain plug (Figure 52) and let the oil flow into a drain pan. When the oil stops, install the drain plug.

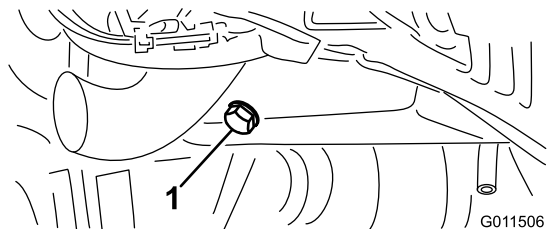

Figure 52

1. Engine oil drain plug

2. Remove the oil filter (Figure 53). Apply a light coat of clean oil to the new filter seal before screwing it on. **Do not overtighten.**

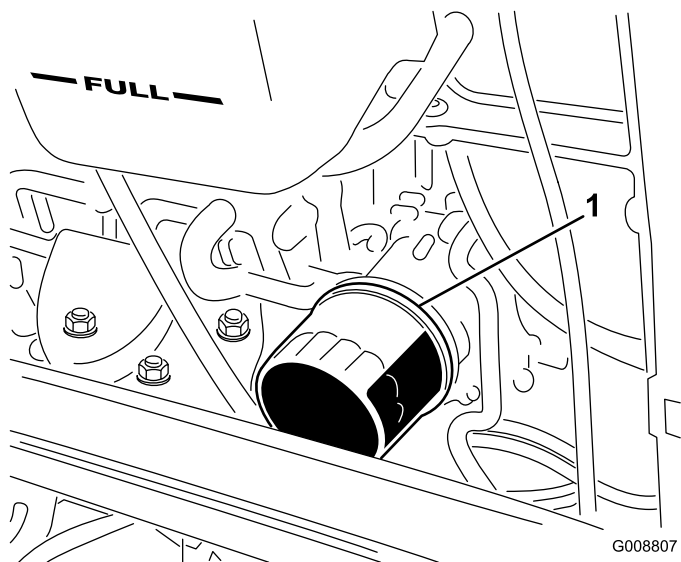

Figure 53

1. Engine oil filter

3. Add oil to the crankcase; refer to Checking the Engine Oil.

Fuel System Maintenance

Servicing the Fuel System

⚠ DANGER

Under certain conditions, diesel fuel and fuel vapors are highly flammable and explosive. A fire or explosion from fuel can burn you and others and can cause property damage.

- Use a funnel and fill the fuel tank outdoors, in an open area, when the engine is off and is cold. Wipe up any fuel that spills.
- Do not fill the fuel tank completely full. Add fuel to the fuel tank until the level is 1/4 to 1/2 inch (6 to 13 mm) below the bottom of the filler neck. This empty space in the tank allows the fuel to expand.
- Never smoke when handling fuel, and stay away from an open flame or where fuel fumes may be ignited by a spark.
- Store fuel in a clean, safety-approved container and keep the cap in place.

Fuel Tank

Service Interval: Every 800 hours

Drain and clean the fuel tank every 800 hours. Also, drain and clean the tank if fuel system becomes contaminated or if the machine will be stored for an extended period of time. Use clean fuel to flush out the tank.

Fuel Lines and Connections

Service Interval: Every 400 hours

Check the fuel lines and connections every 400 hours or yearly, whichever comes first. Inspect them for deterioration, damage, or loose connections.

Servicing the Water Separator

Service Interval: Every 400 hours

Drain water or other contaminants from water separator (Figure 54) daily. Replace filter canister after every 400 hours of operation.

1. Place a clean container under the fuel filter.
2. Loosen the drain plug on the bottom of the filter canister.

Electrical System Maintenance

Battery Care

Battery type is group 24.

Important: Before welding on the machine, disconnect the negative cable from the battery to prevent damage to the electrical system.

Note: Check the battery condition weekly or after every 50 hours of operation. Keep the terminals and the entire battery case clean because a dirty battery will discharge slowly. To clean the battery, wash the entire case with a solution of baking soda and water. Rinse with clear water. Coat the battery posts and cable connectors with Grafo 112X (skin-over) grease (Toro Part No. 505-47) or petroleum jelly to prevent corrosion.

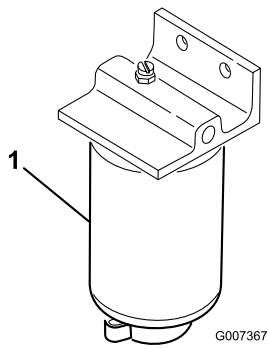

Figure 54

1. Water separator filter canister
-
3. Clean the area where the filter canister mounts.
 4. Remove the filter canister and clean the mounting surface.
 5. Lubricate the gasket on the filter canister with clean oil.
 6. Install the filter canister by hand until the gasket contacts mounting surface, then rotate it an additional 1/2 turn.
 7. Tighten the drain plug on the bottom of the filter canister.

Bleeding Air from the Injectors

1. Loosen the tube connection to the Number 1 injector nozzle and holder assembly at the injection pump (Figure 55).

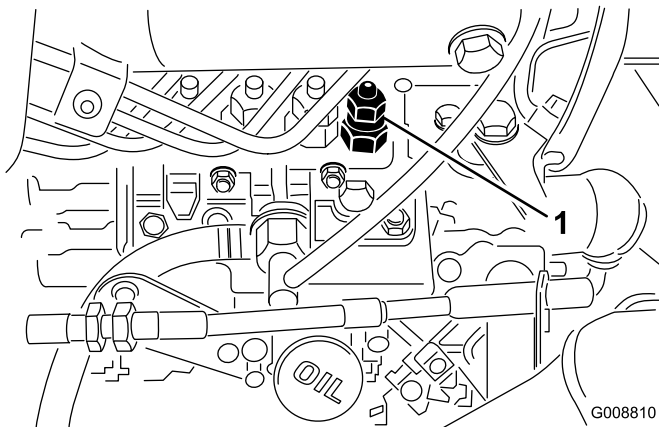

Figure 55

1. Number 1 injector nozzle
-
2. Move the throttle to the Fast position.
 3. Turn the key in the ignition switch to the Start position and watch the fuel flow around the connector. Turn the key to the Off position when solid flow is observed.
 4. Tighten the tube connector securely.
 5. Repeat the procedure on the remaining nozzles.

WARNING

CALIFORNIA Proposition 65 Warning

Battery posts, terminals, and related accessories contain lead and lead compounds, chemicals known to the State of California to cause cancer and reproductive harm.
Wash hands after handling.

1. Raise the seat and secure it with the prop rod.
2. Remove the battery cover (Figure 56).

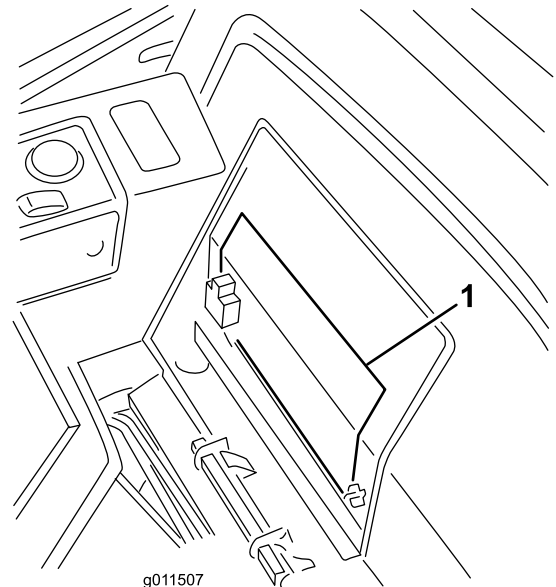

Figure 56

1. Battery cover

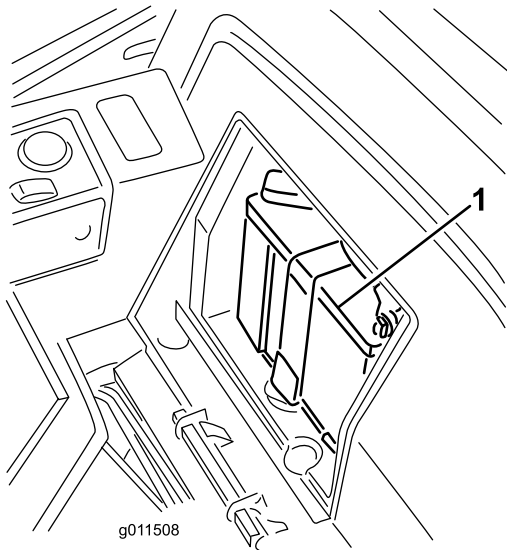

Figure 57

1. Battery

⚠ WARNING

Charging the battery produces gasses that can explode.

Never smoke near the battery and keep sparks and flames away from battery.

3. Remove the rubber boot from the positive terminal and inspect the battery.

⚠ WARNING

Battery terminals or metal tools could short against metal components causing sparks. Sparks can cause the battery gasses to explode, resulting in personal injury.

- When removing or installing the battery, do not allow the battery terminals to touch any metal parts of the machine.
- Do not allow metal tools to short between the battery terminals and metal parts of the machine.

⚠ WARNING

Incorrect battery cable routing could damage the machine and cables causing sparks. Sparks can cause the battery gasses to explode, resulting in personal injury.

- Always *disconnect* the negative (black) battery cable before disconnecting the positive (red) cable.
 - Always *connect* the positive (red) battery cable before connecting the negative (black) cable.
4. Coat both battery connections with Grafo 112X (skin-over) grease, Toro Part No. 505-47, petroleum jelly, or light grease to prevent corrosion. Slide the rubber boot over the positive terminal.
 5. Install the battery cover.

Fuses

There traction unit fuses (Figure 58 thru Figure 60) are located under the hood in the fuse box.

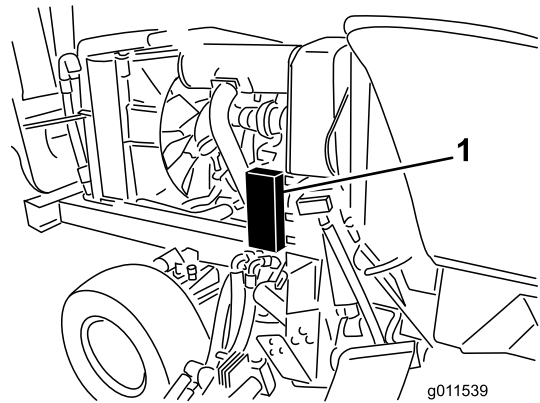

Figure 58

1. Fuse box

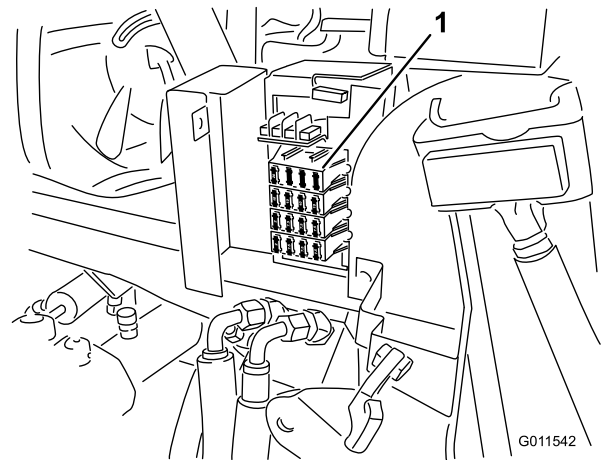

Figure 59

1. Fuses

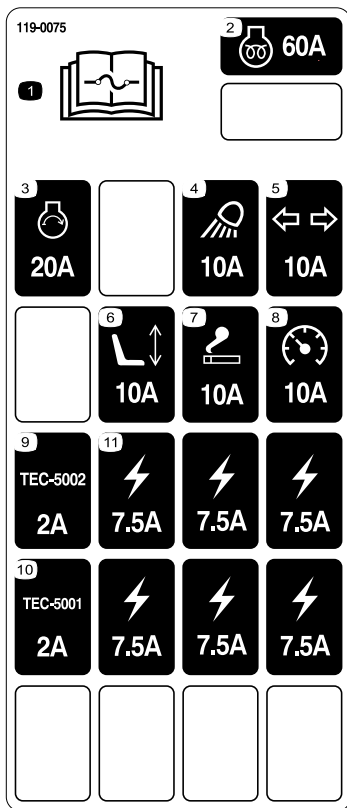

Figure 60

- | | |
|--|----------------------------|
| 1. Read the <i>Operator's Manual</i> for fuse information. | 7. Powerpoint—10A fuse |
| 2. Engine preheat—60A fuse | 8. Instruments—10A fuse |
| 3. Engine, start—20A fuse | 9. Control module—2A fuse |
| 4. Headlights—10A fuse | 10. Control module—2A fuse |
| 5. Signal lights—10A fuse | 11. Powerpoint—7.5A fuse |
| 6. Power Seat—10A fuse | |

The cab fuses (Figure 61 & Figure 62) are located in the fuse box in the cab headliner (model 30446 only).

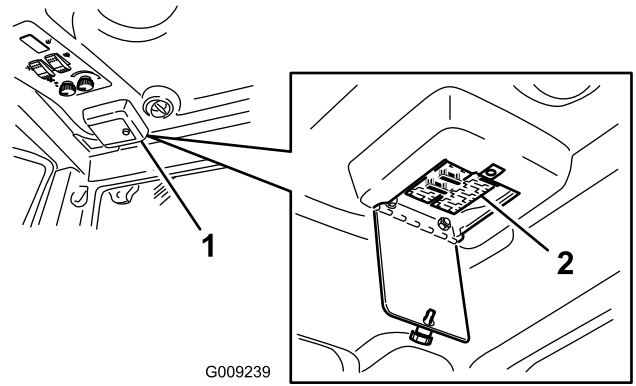

Figure 61

- | | |
|-----------------|----------|
| 1. Cab fuse box | 2. Fuses |
|-----------------|----------|

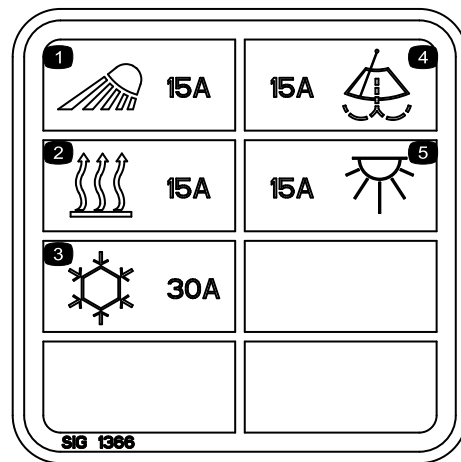

Figure 62

Drive System Maintenance

Changing the Planetary Gear Drive Oil

Service Interval: After the first 200 hours

Every 800 hours

Change the oil initially after first 200 hours of operation. Thereafter change the oil every 800 hours, or yearly, whichever occurs first. Use a high quality SAE 85W-140 gear lube.

1. Jack up the front of the machine and support with jack stands.
2. Remove the front wheels.
3. Rotate the wheel so that the check/drain plug (Figure 63) is at the lowest position.

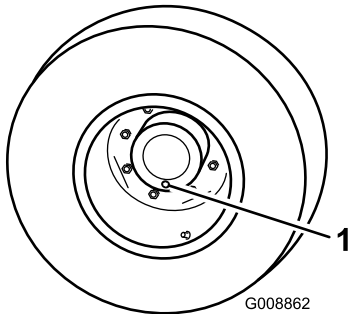

Figure 63

1. Check/drain plug

4. Place a drain pan under the hub, remove the plug, and allow the oil to drain.
5. When all of the oil has drained, position the wheel so that the plug hole is at the 3 or 9 o'clock position.
6. Place a drain pan under the brake housing on the other side of the wheel (Figure 64).
7. Remove the plug from the bottom of the housing and allow the oil to drain.
8. When all of the oil has drained, install the plug in the housing.
9. Add approximately 16 oz (0.5 l) of high quality SAE 85W-140 gear lube to the planetary fill hole (at the 3 or 9 o'clock position) until the level is up to the bottom of the brake housing check hole. Install the plug.
10. Repeat the procedure on the opposite gear assembly.

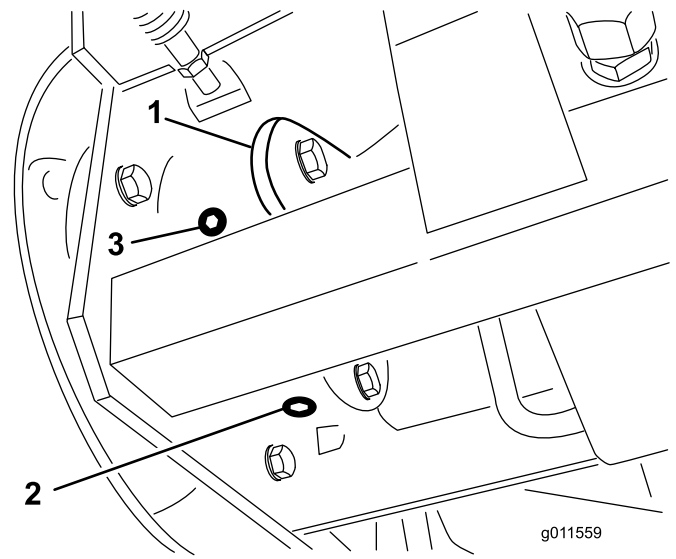

Figure 64

1. Brake housing
2. Drain plug
3. Check plug

Changing the Rear Axle Lubricant

Service Interval: After the first 200 hours

Every 800 hours

Change the oil initially after the first 200 hours of operation and every 800 hours of operation thereafter.

1. Position the machine on a level surface.
2. Clean the area around the 3 drain plugs; 1 on each end and 1 in the center (Figure 65).
3. Remove the check plugs to ease in draining of the oil.
4. Remove the drain plugs and allow the oil to drain into the pans.

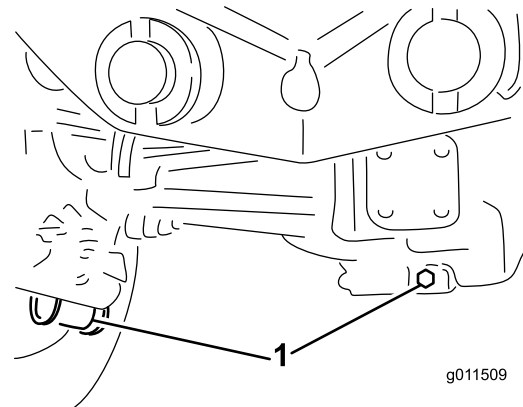

Figure 65

1. Drain plug location

5. Clean the area around the drain plug on the bottom of the gear box (Figure 66).

- Remove the drain plug from the gear box and allow the oil to drain into a pan. Remove the fill plug to ease in draining of the oil.

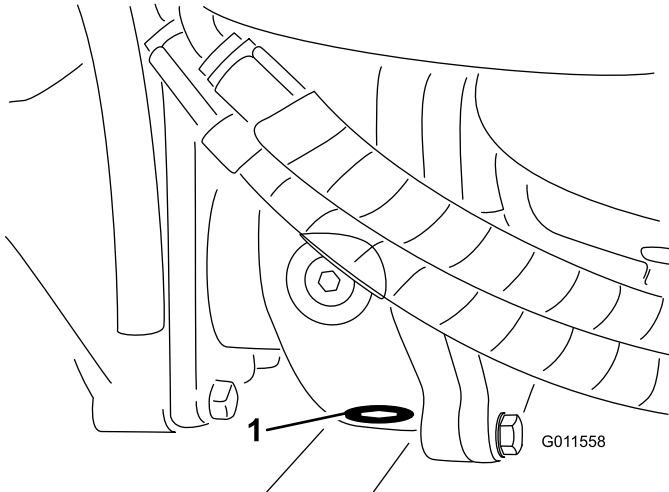

Figure 66

- Drain plug

- Add enough oil to bring the level up to the bottom of the check plug holes; refer to Checking the Rear Axle Lubricant, and Checking the Rear Axle Gear Box Lubricant.
- Install the plugs.

Checking the Rear Wheel Toe-In

Service Interval: Every 800 hours

After every 800 operating hours or annually, check the rear wheel toe-in.

- Measure the center-to-center distance (at axle height) at the front and rear of the steering tires. The front measurement must be 1/4 inch (6 mm) less than the rear measurement.
- To adjust, loosen the clamps at both ends of the tie rods.
- Rotate the tie rod end to move the front of the tire inward or outward.
- Tighten the tie rod clamps when the adjustment is correct.

Cooling System Maintenance

Servicing the Engine Cooling System

Remove debris from the oil cooler and radiator daily. Clean them more frequently in dirty conditions.

This machine is equipped with a hydraulically driven fan drive system that automatically (or manually) reverses to reduce radiator and screen debris build-up. While this feature can help reduce the time required to clean radiators and coolers, it does not eliminate the need for routine cleaning. Periodic cleaning and inspection of the radiator is still required.

- Turn the engine off and raise the hood. Clean the engine area thoroughly of all debris.
- Remove the knobs (Figure 67) securing the oil cooler to the frame.

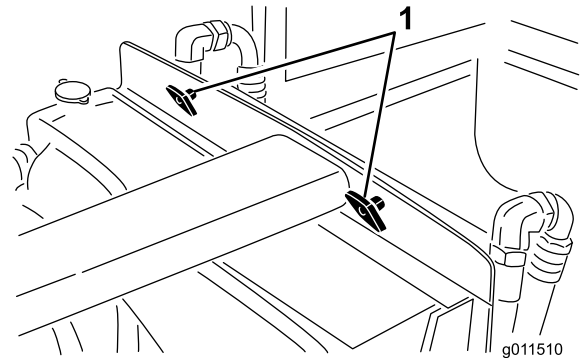

Figure 67

- Knobs
- Pivot the oil cooler rearward. Clean both sides of the oil cooler and radiator area (Figure 68) thoroughly with compressed air. Start from the fan side and blow the debris out towards the back. Then clean from the back side and blow towards the front. Repeat procedure several times until all chaff and debris is removed.

Important: Cleaning the radiator or oil cooler with water can promote premature corrosion and damage to components.

Brake Maintenance

Adjusting the Service Brakes

Adjust the service brakes when there is more than 1 inch (25 mm) of “free travel” of the brake pedal, or when the brakes do not work effectively. Free travel is the distance the brake pedal moves before braking resistance is felt.

1. Disengage the locking latch from the brake pedals so that both pedals work independently of each other.
2. To reduce free travel of the brake pedals, tighten the brakes:
 - A. Loosen the front nut on the threaded end of the brake cable.
 - B. Tighten the rear nut to move the cable backward until the brake pedals have 1/2 to 1 inch (13 to 25 mm) of free travel.
 - C. Tighten the front nuts after the brakes are adjusted correctly.

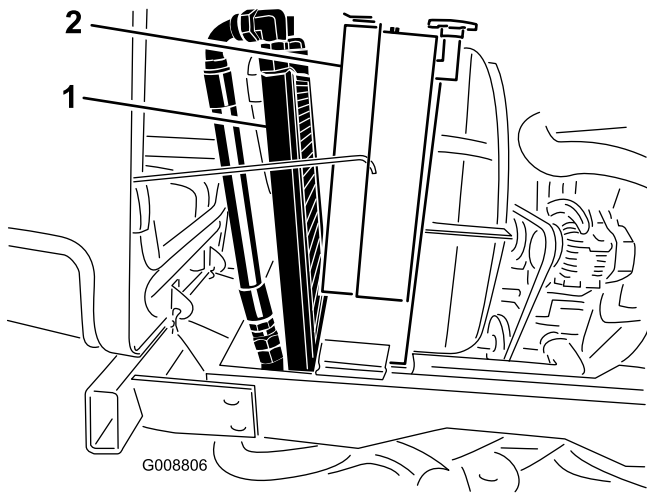

Figure 68

1. Oil cooler

2. Radiator

-
4. Pivot the oil cooler back into position. Secure it to the frame with the knobs and close the hood.

Belt Maintenance

Servicing the Alternator Belt

Service Interval: After the first 10 hours

Every 100 hours

Check the condition and tension of the belt (Figure 69) after every 100 operating hours.

1. Proper tension will allow 3/8 inch (10 mm) deflection when a force of 10 lb is applied on the belt midway between the pulleys.
2. If the deflection is not 3/8 inch (10 mm), loosen the alternator mounting bolts (Figure 69). Increase or decrease the alternator belt tension and tighten the bolts. Check the deflection of the belt again to ensure that the tension is correct.

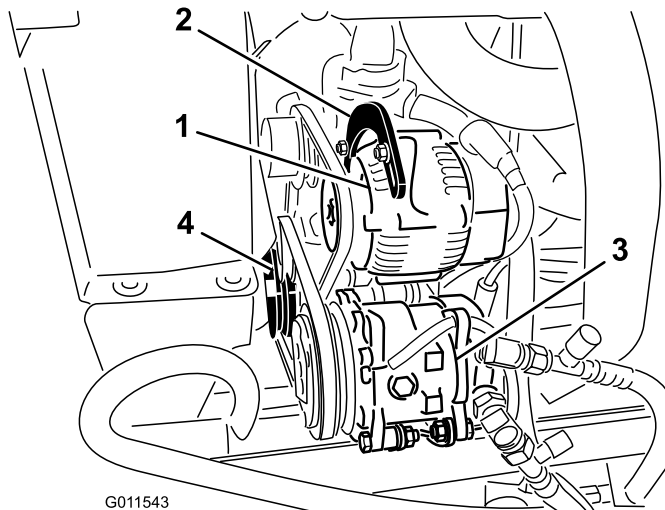

Figure 69

- | | |
|------------------|-----------------|
| 1. Alternator | 3. Compressor |
| 2. Mounting bolt | 4. Idler pulley |

Re-tensioning the Blade Drive Belts

Service Interval: After the first 10 hours

Every 50 hours

Check the condition and tension of the cutting unit drive belts initially after 10 hours of operation and every 50 operating hours thereafter.

When properly tensioned, the extension spring (hook to hook) measurement should be approximately 3.50 ±.25 inch (inside). Once the correct spring tension is attained, adjust the stop bolt (carriage bolt) until there is approximately .125 +.060/-.000 inch clearance between the head of the bolt and the idler arm (Figure 70).

Note: Make sure the belt is positioned on the spring side of the belt guide (Figure 70).

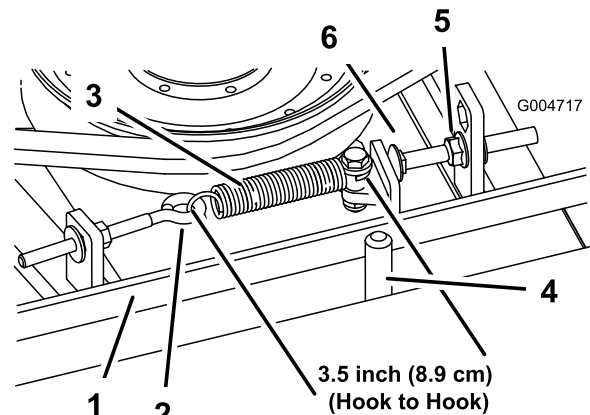

Figure 70

- | | |
|---------------------|---------------|
| 1. Belt | 4. Belt guide |
| 2. Eye bolt | 5. Flange nut |
| 3. Extension spring | 6. Stop bolt |

Servicing the Compressor Belt

Service Interval: After the first 10 hours

Every 100 hours

Model 30446 only

Check the condition and tension of the belt (Figure 69) after every 100 operating hours.

1. Proper tension will allow 3/8 inch (10 mm) deflection when a force of 10 lb is applied on the belt midway between the pulleys.
2. If the deflection is not 3/8 inch (10 mm), loosen the idler pulley mounting bolt (Figure 69). Increase or decrease the compressor belt tension and tighten the bolt. Check the deflection of the belt again to ensure that the tension is correct.

Replacing the Blade Drive Belt

Service Interval: Every 800 hours

The blade drive belt, tensioned by the spring loaded idler pulley, is very durable. However, after many hours of use, the belt will show signs of wear. Signs of a worn belt are: squealing when belt is rotating, blades slipping when cutting grass, frayed edges, burn marks and cracks. Replace the belt if any of these conditions are evident.

1. Lower the cutting unit to the shop floor. Remove the belt covers from the top of the cutting unit and set the covers aside.
2. Loosen the eye bolt allowing the removal of the extension spring (Figure 70).
3. Loosen the flange nut securing the stop bolt to the mounting tab. Back off the nut enough to allow the

idler arm to pass by the stop bolt (Figure 70). Move the idler pulley away from the belt to release belt tension.

Note: If the stop bolt is ever removed from the mounting tab, make sure it is reinstalled in the hole that aligns the stop bolt head with the idler arm.

4. Remove the bolts securing the hydraulic motor to the cutting unit (Figure 71). Lift the motor off of the cutting unit and lay it on top of the cutting unit.

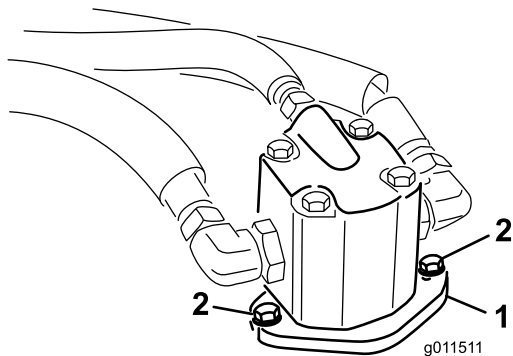

Figure 71

1. Hydraulic motor
2. Mounting bolts

5. Remove the old belt from around the spindle pulleys and idler pulley.
6. Route the new belt around the spindle pulleys and idler pulley assembly.
7. Position the hydraulic motor on the cutting unit after routing the belt around the pulleys. Mount the motor to the cutting unit with the bolts previously removed.

Note: Make sure the belt is positioned on the spring side of the belt guide (Figure 70).

8. Reconnect the extension spring (Figure 70) to the eye bolt and tension the belt as follows:
 - When properly tensioned, the extension spring (hook to hook) measurement should be approximately $3.50 \pm .25$ inch (inside).
 - Once the correct spring tension is attained, adjust the stop bolt (carriage bolt) until there is approximately $.125 +.060 / -.000$ inch clearance between the head of the bolt and the idler arm.

Controls System Maintenance

Adjusting the Throttle Cable

Service Interval: After the first 50 hours—Check the engine speed (at idle and full throttle).

Every 400 hours—Check the engine speed (at idle and full throttle).

Adjust the throttle cable (Figure 72) so that the governor lever on the engine contacts the low and high speed set bolts before the throttle lever contacts the slot in the control panel.

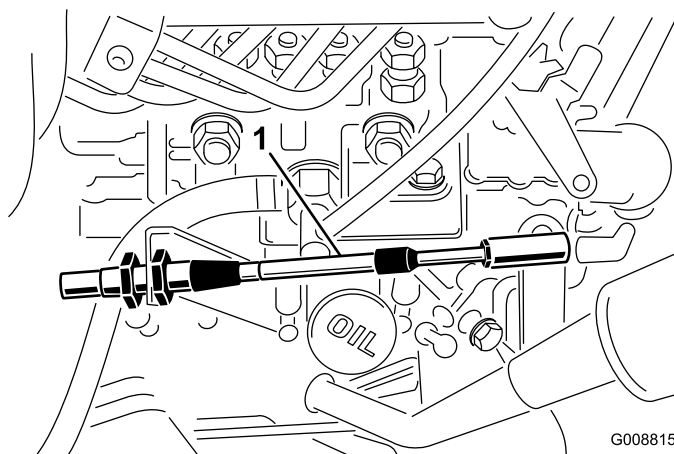

Figure 72

1. Throttle cable

Adjusting the Traction Pedal Linkage

With the traction switch in the mow position (low speed), the traction pedal should contact the stop just before the pump is at full stroke to prevent any damage to the pump. If it does not, perform the following procedure:

1. Park the machine on a level surface, stop the engine, and lower the cutting units to the floor. Remove the ignition key.
2. Depress the traction pedal until it is at full stroke (Figure 73). The jam nuts may have to be loosened and the stop lowered to attain full stroke.

Hydraulic System Maintenance

Changing the Hydraulic Fluid

Service Interval: After the first 200 hours

Every 800 hours

Change the hydraulic fluid after every 800 operating hours, in normal conditions. If the fluid becomes contaminated, contact your local Toro distributor because the system must be flushed. Contaminated fluid looks milky or black when compared to clean oil.

1. Turn the engine off and raise the hood.
2. Loosen the drain valve on the bottom of the reservoir and let the hydraulic fluid flow into large drain pan. Close the valve when the hydraulic fluid stops draining.
3. Fill the reservoir (Figure 74) with approximately 8 U.S. gallons (30 l) of hydraulic fluid; refer to Checking the Hydraulic Fluid.

Important: Use only the hydraulic fluids specified. Other fluids could cause system damage.

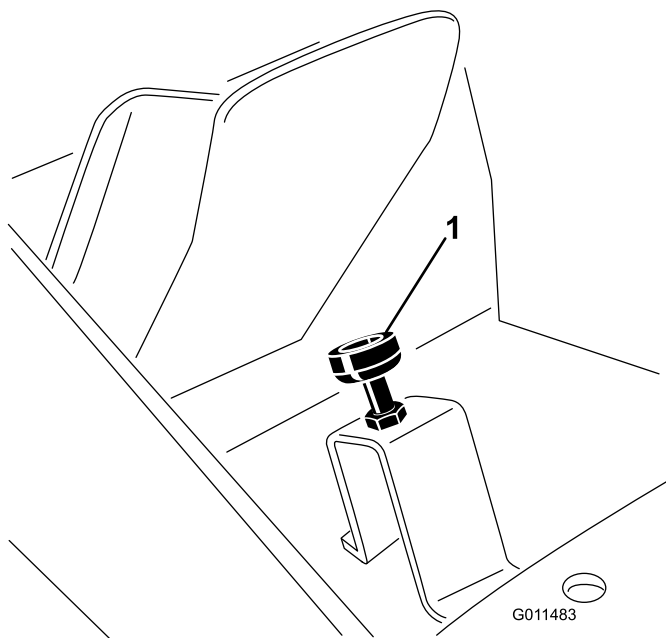

Figure 73

1. Traction pedal stop
 2. Jam nuts
-
3. Release the traction pedal and adjust the stop another half to full turn so that the pedal contacts the stop just before full stroke is attained, then, tighten the jam nuts (Figure 73).

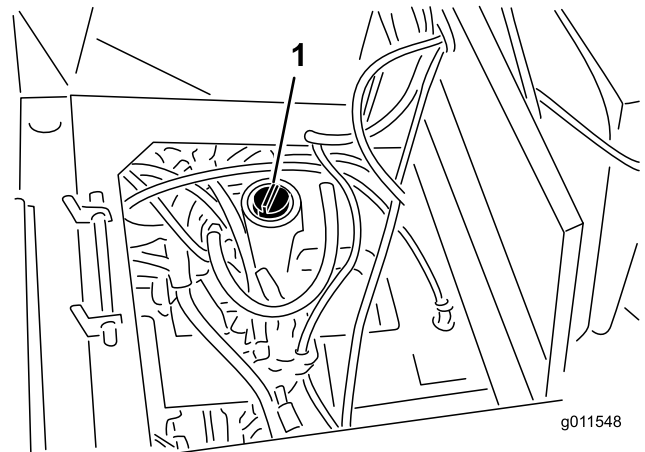

Figure 74

1. Hydraulic reservoir
-
4. Install the reservoir cap. Start the engine and use all of the hydraulic controls to distribute hydraulic fluid throughout the system. Also check for leaks; then stop the engine.
 5. Check the fluid level and add enough to raise level the level to the Full mark on the dipstick. **Do not overfill.**

Replacing the Hydraulic Filters

Service Interval: After the first 200 hours

Every 800 hours

Change the 2 hydraulic filters initially after the first 200 operating hours. Thereafter, change the filters after every 800 operating hours, in normal conditions.

Use Toro replacement filters (Part No. 94-2621 for the left side of the machine and 75-1310 for the right side of the machine).

Important: Use of any other filter may void the warranty on some components.

1. Position the machine on a level surface, lower the cutting units, stop the engine, engage the parking brakes, and remove the ignition key.
2. Clean the area around the filter mounting area. Place a drain pan under the filter and remove the filter (Figure 75).

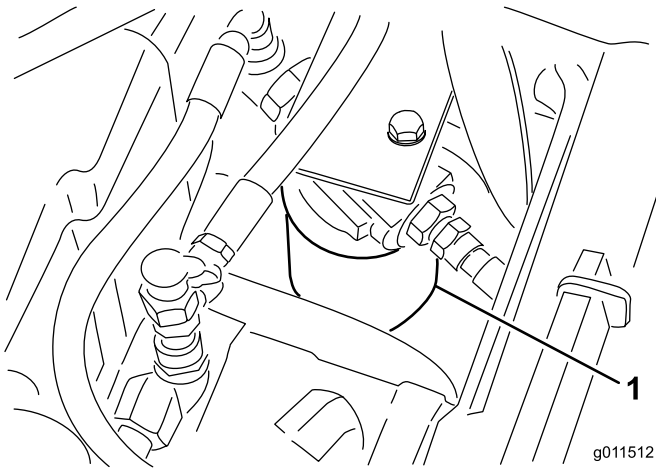

Figure 75

3. Lubricate the new filter gasket and fill the filter with hydraulic fluid.
4. Ensure that the filter mounting area is clean. Screw the filter on until the gasket contacts the mounting plate; then tighten the filter an additional 1/2 turn.
5. Once the reservoir is filled, start the engine and let it run at low idle for approximately two minutes. Activate steering and raise/lower cutting units several times to purge air from the system. Stop the engine and check for leaks.

Checking the Hydraulic Lines and Hoses

Service Interval: Every 2 years

Inspect the hydraulic lines and hoses daily for leaks, kinked lines, loose mounting supports, wear, loose fittings, weather deterioration, and chemical deterioration. Make all necessary repairs before operating.

⚠ WARNING

Hydraulic fluid escaping under pressure can penetrate skin and cause injury.

- **Make sure all hydraulic fluid hoses and lines are in good condition and all hydraulic connections and fittings are tight before applying pressure to the hydraulic system.**
- **Keep your body and hands away from pin hole leaks or nozzles that eject high pressure hydraulic fluid.**
- **Use cardboard or paper to find hydraulic leaks.**
- **Safely relieve all pressure in the hydraulic system before performing any work on the hydraulic system.**
- **Seek immediate medical attention if fluid is injected into skin.**

Adjusting the Counterbalance Pressure

The counterbalance test port (Figure 76) is used to test the pressure in the counterbalance circuit. Recommended counterbalance pressure is 470 psi (3241 kPa). To adjust the counterbalance pressure, loosen the locknut, rotate the adjusting screw (Figure 76) clockwise to increase the pressure or counterclockwise to decrease the pressure and tighten the locknut

Note: All three side cutting units castor wheels should remain on the ground with counterbalance applied.

Mower Maintenance

Adjusting the Transport Latch

If the transport latch (Figure 77) has to be adjusted, adjust as follows:

1. Raise the front cutting unit fully off of the floor, set the parking brake, and stop the engine. Remove the ignition key.
2. Loosen flange nuts securing latch arm pivot to traction unit frame.
3. Move latch arm pivot in or out until rubber cushion of adjustment screw is centered under deck latch. Tighten flange nuts.

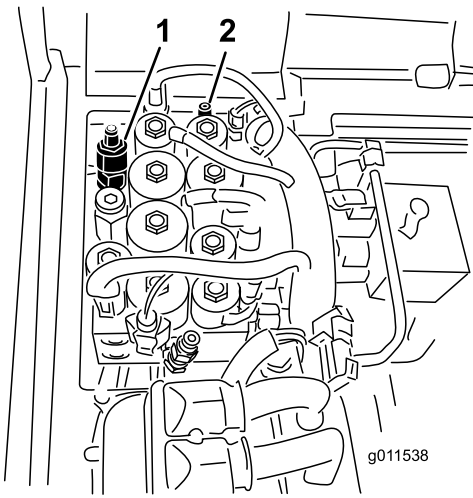

Figure 76

1. Counterbalance adjusting screw
 2. Counterbalance test port screw
-

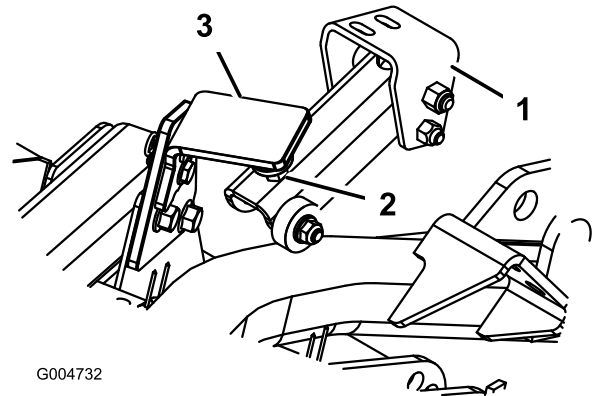

Figure 77

1. Latch arm pivot
 2. Adjustment screw
 3. Deck latch
-

4. Clearance between adjustment screw rubber (Figure 78) cushion and deck latch should be .125 inch. If an adjustment is required, loosen nut on adjustment screw, adjust screw until required clearance is attained and tighten nut.

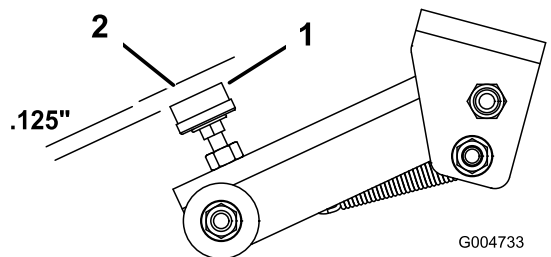

Figure 78

1. Adjustment screw
 2. Deck latch
-

Pivoting (Tilting) the Front Cutting Unit Upright

Note: Although not needed for normal maintenance procedures, the front cutting unit can be pivoted (tilted) to an upright position. Should you desire to tilt the cutting unit, proceed as follows:

1. Raise the front cutting unit slightly off of the floor, set the parking brake, and stop the engine. Remove the ignition key.
2. Remove the hairpin cotter and clevis pin securing the deck transport latch to the latch plate (Figure 79). Pivot latch toward rear of deck.

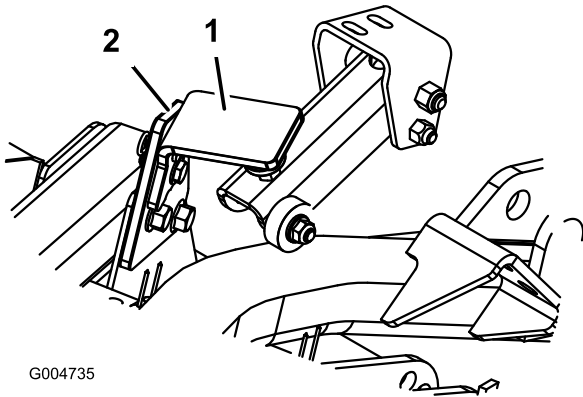

Figure 79

1. Transport latch
2. Latch plate

3. Remove the hairpin cotter and clevis pin securing the height-of-cut chains to the rear of the cutting unit.
4. Start the engine, slowly raise the front cutting unit, and stop the engine. Remove the ignition key.
5. Grasp the front of the cutting unit and lift it to an upright position.
6. Hold the cutting unit upright, fit the cable end over the pin on the cutting unit lift arm and secure it with the hairpin cotter (Figure 80).

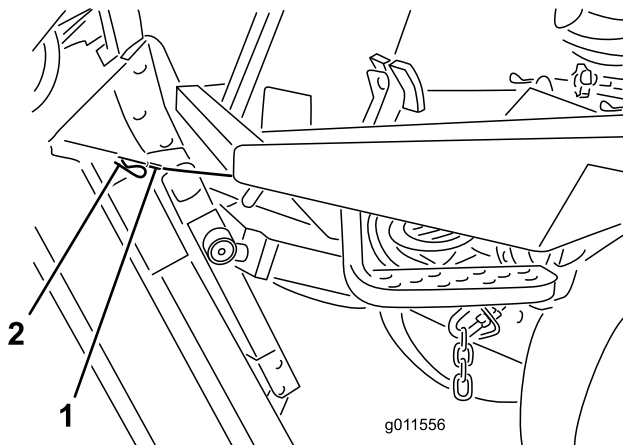

Figure 80

1. Cable
2. Pin

Pivoting the Front Cutting Unit Down

1. With the help of another person, hold the cutting unit upright, remove the hairpin cotter securing the cable end, and remove the cable from the pin.
2. Pivot (tilt) the cutting unit downward.
3. Store the cable under the operator's platform.
4. Sit on the seat, start the engine, and lower the cutting unit until it is slightly off of the floor.
5. Secure the height-of-cut chains to the rear of the cutting unit.
6. Pivot transport latch upward into position and secure with clevis pin and cotter pin.

Adjusting the Cutting Unit Pitch

Measuring the Cutting Unit Pitch

Cutting unit pitch is the difference in height-of-cut from the front of the blade plane to the back of the blade plane. Toro recommends a blade pitch of 1/4 inch (6 mm). That is the back of the blade plane is 1/4 inch (6 mm) higher than the front.

1. Position the machine on a level surface on the shop floor.
2. Set the cutting unit to the desired height-of-cut.
3. Rotate 1 blade so that it points straight forward.
4. Using a short ruler, measure from the floor to the front tip of the blade. Rotate the blade tip to the rear and measure from the floor to the tip of the blade.
5. Subtract the front dimension from the rear dimension to calculate the blade pitch.

Adjusting the Front Cutting Unit

1. Loosen the jam nuts on the top or bottom of the height-of-cut chain U-bolt (Figure 81).
2. Adjust the other set of nuts to raise or lower the rear of the cutting unit and attain the correct cutting unit pitch.
3. Tighten the jam nuts.

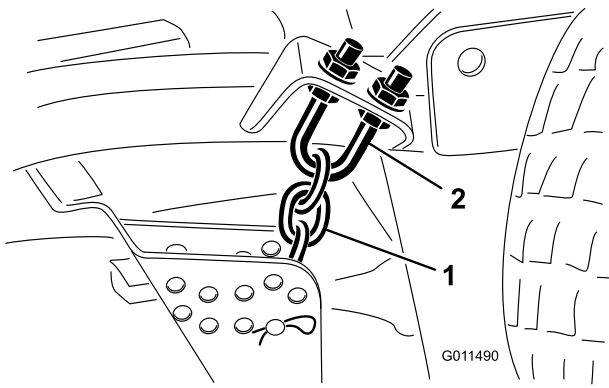

Figure 81

1. Height-of-cut chain 2. U-bolt

Adjusting the Side Cutting Units

Service Interval: Every 800 hours

1. Remove the tensioning cap from the spindle shaft and slide the spindle out of the castor arm (Figure 82). Reposition the shims, as required, to raise or lower the castor wheel until the cutting unit has the correct pitch.

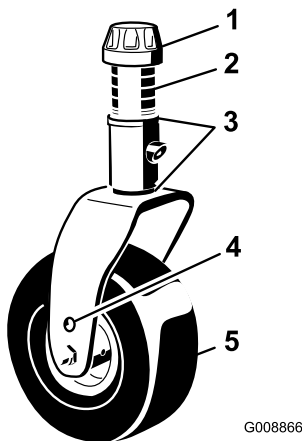

Figure 82

1. Tensioning cap 4. Axle mounting holes
 2. Spacers 5. Castor wheel
 3. Shims

2. Install the tensioning cap.

Servicing the Castor Arm Bushings

The castor arms have bushings pressed into the top and bottom of the tube and after many hours of operation, the bushings will wear. To check the bushings, move the castor fork back and forth and from side to side. If the castor spindle is loose inside the bushings, the bushings are worn and must be replaced.

1. Raise the cutting unit so that the wheels are off of the floor. Block the cutting unit so that it cannot accidentally fall.
2. Remove the tensioning cap, spacer(s), and thrust washer from the top of the castor spindle.
3. Pull the castor spindle out of the mounting tube. Allow the thrust washer and spacer(s) to remain on the bottom of the spindle.
4. Insert a pin punch into the top or bottom of the mounting tube and drive the bushing out of the tube (Figure 83). Also drive the other bushing out of the tube. Clean the inside of the tubes to remove dirt.

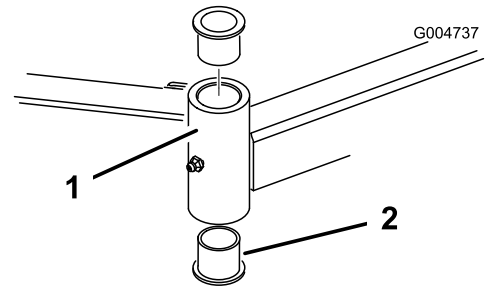

Figure 83

1. Castor arm tube 2. Bushings

5. Apply grease to the inside and outside of the new bushings. Using a hammer and flat plate, drive the bushings into the mounting tube.
6. Inspect the castor spindle for wear and replace it if it is damaged.
7. Push the castor spindle through the bushings and mounting tube. Slide the thrust washer and spacer(s) onto the spindle. Install the tensioning cap on the castor spindle to retain all parts in place.

Servicing the Castor Wheels and Bearings

Service Interval: Every 800 hours

1. Remove the locknut from the bolt holding the castor wheel assembly between the castor fork (Figure 84) or the castor pivot arm (Figure 85). Grasp the castor wheel and slide the bolt out of the fork or pivot arm.

Blade Maintenance

Checking for a Bent Blade

After striking a foreign object, inspect the machine for damage and make repairs before restarting and operating the equipment. Torque all the spindle pulley nuts to 130 to 150 ft-lb (176 to 203 N·m).

1. Position the machine on a level surface. Raise the cutting unit, engage the parking brake, put the traction pedal in neutral, put the PTO lever in the Off position, stop the engine, and remove the ignition key. Block the cutting unit to prevent it from accidentally falling.
2. Rotate the blade until the ends face forward and backward (Figure 86). Measure from the inside of the cutting unit to the cutting edge at the front of the blade. Remember this dimension.

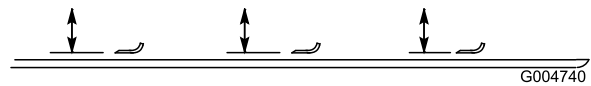

Figure 86

3. Rotate the opposite end of the blade forward. Measure between the cutting unit and cutting edge of the blade at the same position as in step 2. The difference between the dimensions obtained in steps 2 and 3 must not exceed 1/8 inch (3 mm). If the dimension exceeds 1/8 inch (3 mm), the blade is bent and must be replaced; refer to Removing and Installing the Cutter Blade.

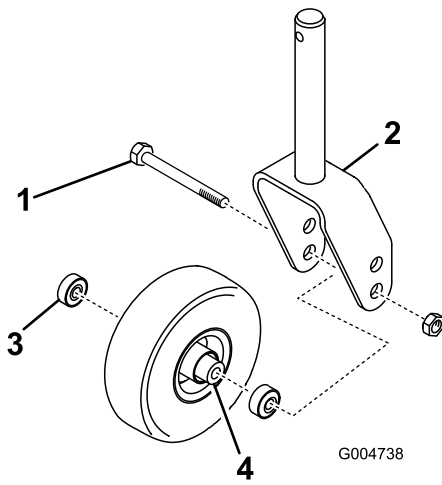

Figure 84

- | | |
|----------------|-------------------|
| 1. Castor bolt | 3. Bearing |
| 2. Castor fork | 4. Bearing spacer |

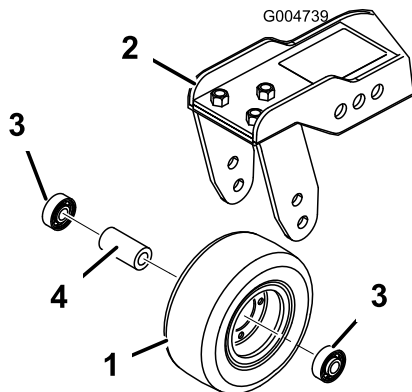

Figure 85

- | | |
|---------------------|-------------------|
| 1. Castor wheel | 3. Bearing |
| 2. Castor pivot arm | 4. Bearing spacer |

2. Remove the bearing from the wheel hub and allow the bearing spacer to fall out (Figure 84 and Figure 85). Remove the bearing from the opposite side of the wheel hub.
3. Check the bearings, spacer, and inside of the wheel hub for wear. Replace any damaged parts.
4. To assemble the castor wheel, push the bearing into the wheel hub. When installing the bearings, press on the outer race of the bearing.
5. Slide the bearing spacer into the wheel hub. Push the other bearing into the open end of the wheel hub to captivate the bearing spacer inside the wheel hub.
6. Install the castor wheel assembly between the castor fork and secure it in place with the bolt and locknut.

Removing and Installing the Cutter Blade(s)

The blade must be replaced if a solid object is hit, the blade is out of balance, or if the blade is bent. Always use genuine Toro replacement blades to be sure of safety and optimum performance. Never use replacement blades made by other manufacturers because they could be dangerous.

1. Raise the cutting unit to the highest position, engage the parking brake, stop the engine, and remove the ignition key. Block the cutting unit to prevent it from accidentally falling.
2. Grasp the end of the blade using a rag or thickly padded glove. Remove the blade bolt, anti-scalp cup, and blade from the spindle shaft (Figure 87).
3. Install the blade, anti-scalp cup, and blade bolt. Tighten the blade bolt to 85 to 110 ft-lb (115 to 149 N·m).

Important: The curved part of the blade must be pointing toward the inside of the cutting unit to ensure proper cutting.

Note: After striking a foreign object, torque all the spindle pulley nuts to 130 to 150 ft-lb (176 to 203 N·m).

G004741

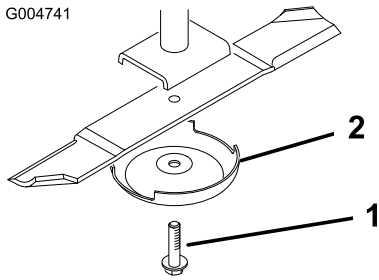

Figure 87

1. Blade bolt

2. Anti-scalp cup

Inspecting and Sharpening the Cutter Blade(s)

⚠ DANGER

A worn or damaged blade can break, and a piece of the blade could be thrown into the operator's or bystander's area, resulting in serious personal injury or death. Trying to repair a damaged blade may result in discontinued safety certification of the product.

- Inspect the blade periodically for wear or damage.
- Never try to straighten a blade that is bent or weld a broken or cracked blade.
- Replace a worn or damaged blade.

Two areas must be considered when checking and servicing the cutter blade—the sail and the cutting edge. Both cutting edges and the sail, which is the turned up portion opposite the cutting edge, contribute to a good quality-of-cut. The sail is important because it lifts the grass up straight, thereby producing an even cut. However, the sail will gradually wear down during operation, and this condition is normal. As the sail wears down, the quality-of-cut will degrade somewhat, although the cutting edges are sharp. The cutting edge of the blade must be sharp so that the grass is cut rather than torn. A dull cutting edge is evident when the tips of the grass appear brown and shredded. Sharpen the cutting edges to correct this condition.

1. Position the machine on a level surface. Raise the cutting unit, engage the parking brake, put the traction pedal in neutral, put the PTO lever in the Off position, stop the engine, and remove the ignition key.
2. Examine the cutting ends of the blade carefully, especially where the flat and curved parts of the blade meet (Figure 88). Since sand and abrasive material can wear away the metal that connects the flat and curved parts of the blade, check the blade before using the mower. If wear is noticed (Figure 88), replace the blade.

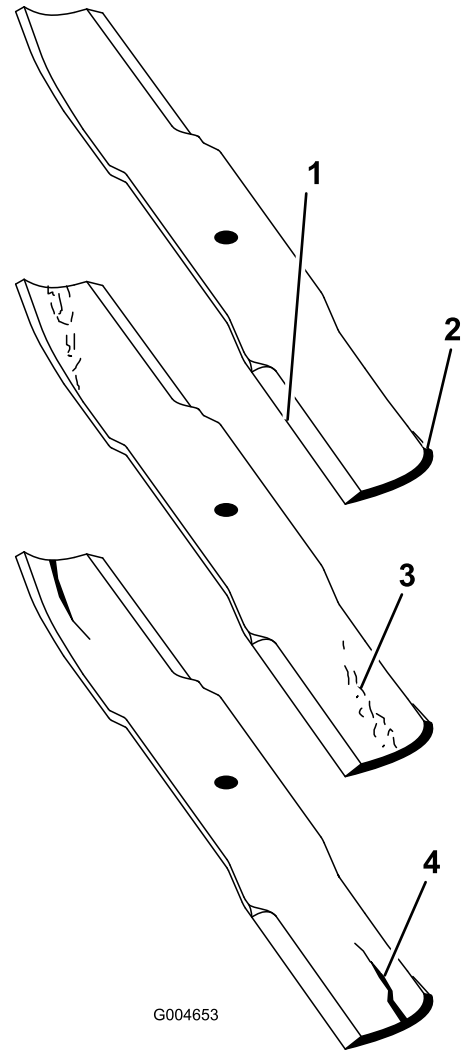

G004653

Figure 88

1. Cutting Edge

3. Wear/slot Forming

2. Curved Area

4. Crack

3. Examine the cutting edges of all of the blades. Sharpen the cutting edges if they are dull or nicked. Sharpen only the top of the cutting edge and maintain the original cutting angle to make sure of sharpness (Figure 89). The blade will remain balanced if the same amount of metal is removed from both cutting edges.

⚠ DANGER

If the blade is allowed to wear, a slot will form between the sail and flat part of the blade. Eventually a piece of the blade may break off and be thrown from under the housing, possibly resulting in serious injury to you or bystanders.

- Inspect the blade periodically for wear or damage.
- Never try to straighten a blade that is bent or weld a broken or cracked blade.
- Replace a worn or damaged blade.

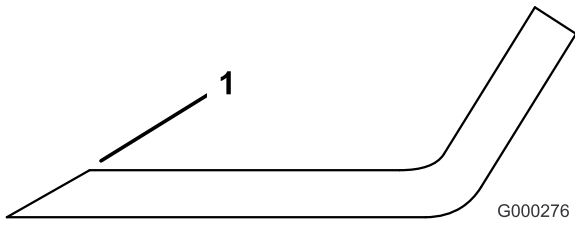

Figure 89

1. Sharpen at original angle

Note: Remove the blades and sharpen them on a grinder. After sharpening the cutting edges, install the blade with the anti-scalp cup and blade bolt; refer to Removing and Installing the Cutter Blade(s).

Correcting Cutting Unit Mismatch

If there is mismatch between the blades, on a single cutting unit, the grass will appear streaked when it is cut. This problem can be corrected by making sure that the blades are straight and all of the blades are cutting on the same plane.

1. Using a 3 foot (1 meter) long carpenters level, find a level surface on the shop floor.
2. Raise the height-of-cut to the highest position; refer to Adjusting the Height-Of-Cut.
3. Lower the cutting unit onto the flat surface. Remove the covers from the top of the cutting unit.
4. Loosen the flange nut securing the idler pulley to release the belt tension.
5. Rotate the blades until the ends face forward and backward. Measure from the floor to the front tip of the cutting edge. Remember this dimension. Then rotate the same blade so that the opposite end is forward, and measure again. The difference between the dimensions must not exceed 1/8 inch (3 mm). If the dimension exceeds 1/8 inch (3 mm), replace the blade because it is bent. Make sure to measure all of the blades.

6. Compare the measurements of the outer blades with the center blade. The center blade must not be more than 3/8 inch (10 mm) lower than the outer blades. If the center blade is more than 3/8 inch (10 mm) lower than the outer blades, proceed to step 7 and add shims between the spindle housing and the bottom of the cutting unit.
 7. Remove the bolts, flat washers, lock washers, and nuts from the outer spindle in the area where the shims must be added. To raise or lower the blade, add a shim, Part No. 3256-24, between the spindle housing and the bottom of the cutting unit. Continue to check the alignment of the blades and add shims until the tips of the blades are within the required dimension.
- Important:** Do not use more than three shims at any one hole location. Use decreasing numbers of shims in adjacent holes if more than one shim is added to any one hole location.
8. Adjust the idler pulley and install the belt covers.

Spark Arrestor Maintenance

Servicing the Spark Arrestor Muffler

Service Interval: Every 200 hours

Every 200 hours operation, clear the muffler of carbon buildup.

1. Remove the pipe plug from the clean-out port at the lower side of the muffler.

⚠ CAUTION

The muffler may be hot and could cause injury.

Be careful while working around the muffler.

2. Start the engine. Plug the normal muffler exit with a block of wood or metal plate so that the exhaust flow will be forced out of the clean-out port. Continue to block the exit until carbon deposits cease coming out of the port.

⚠ CAUTION

Do not stand in line with the clean-out port.

Always wear safety glasses.

3. Stop the engine and replace the pipe plug.

Cab Maintenance

Cleaning the Cab Air Filters

Service Interval: Every 250 hours (Replace them if they are torn or excessively dirty.)

1. Remove the thumb screws and grates from over both the in-cab and rear cab air filters (Figure 90).

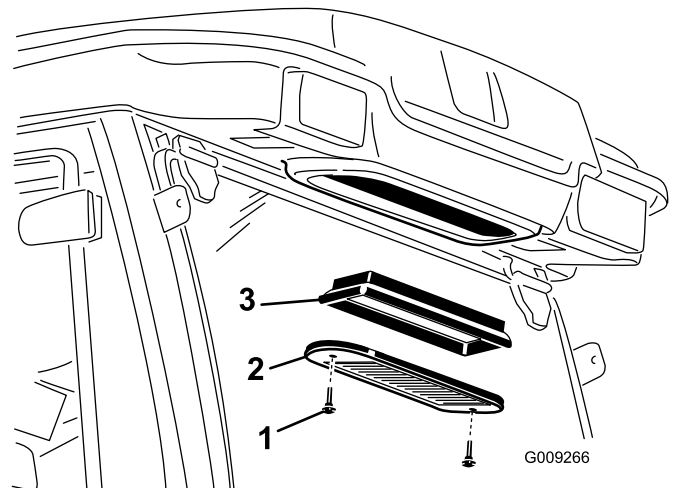
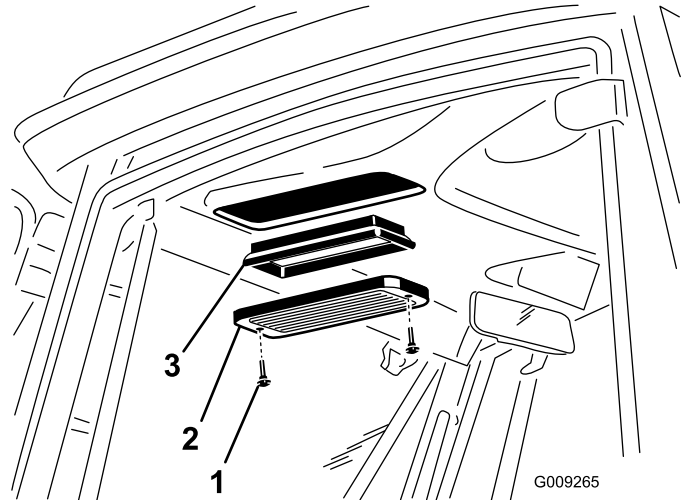

Figure 90

1. Thumb screw
2. Grate
3. Air filter

2. Clean the filters by blowing clean, oil free, compressed air through them.

Important: If either filter has a hole, tear, or other damage, replace it.

3. Install the filters and grate, securing them with the thumb screws.

Cleaning the Air Conditioning Coil

Service Interval: Every 250 hours (Clean more frequently in extremely dusty or dirty conditions)

1. Stop the engine and remove the key.
2. Remove the (4) screws securing the fan and the condenser cover to the fan mount (Figure 91).
3. Carefully lift the fan out of the condenser cover.

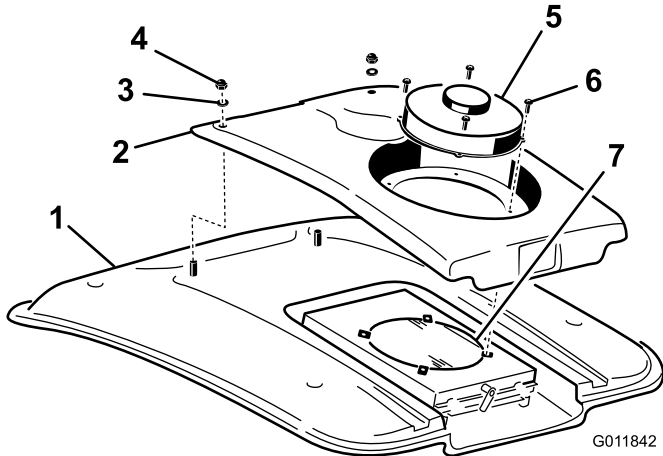

Figure 91

- | | |
|--------------------|-------------------------------|
| 1. Cabin roof | 5. Fan |
| 2. Condenser cover | 6. Screw |
| 3. Washer | 7. Air conditioning condenser |
| 4. Nut | |

4. Remove the two nuts and washers securing the front of the condenser cover to the cab roof (Figure 91).
5. Unplug the fan wire connectors located between the cover and roof.
6. Remove the fan and the cover.
7. Remove and clean the A/C Condenser Screen. Refer to Cleaning the A/C Condenser Screen.
8. Clean the air conditioning condenser thoroughly with compressed air (Figure 91).
9. Replace the A/C Condenser Screen.
10. Replace the condenser cover and fan. Make sure to connect the fan wires before securing the condenser cover.

Cleaning the A/C Condenser Screen

Service Interval: Every 50 hours (Clean more frequently in extremely dusty or dirty conditions)

1. Stop the engine and remove the key.
2. On the rear of the fan mount, rotate the latch to the side (Figure 92).

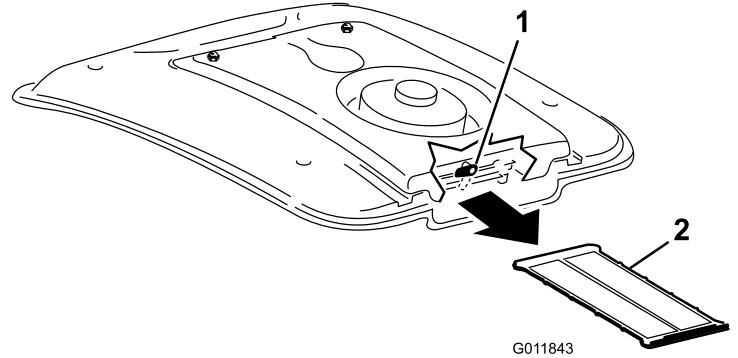

Figure 92

- | | |
|----------|---------------|
| 1. Latch | 2. A/C screen |
|----------|---------------|

3. Slide the A/C screen out from under the air conditioning coil (Figure 92).
4. Clean the screen thoroughly with compressed air (Figure 92).
5. Slide the screen into the channels under the air conditioning coil and rotate the latch downward.

Storage

Preparing for Seasonal Storage

Traction Unit

1. Thoroughly clean the traction unit, cutting units, and the engine.
2. Check the tire pressure; refer to Checking the Tire Pressure.
3. Check all fasteners for looseness; tighten as necessary.
4. Grease or oil all grease fittings and pivot points. Wipe up any excess lubricant.
5. Lightly sand and use touch-up paint on painted areas that are scratched, chipped, or rusted. Repair any dents in the metal body.
6. Service the battery and cables as follows:
 - A. Remove the battery terminals from the battery posts.
 - B. Clean the battery, terminals, and posts with a wire brush and baking soda solution.
 - C. Coat the cable terminals and battery posts with Grafo 112X skin-over grease (Toro Part No. 505-47) or petroleum jelly to prevent corrosion.
 - D. Slowly recharge the battery every 60 days for 24 hours to prevent lead sulfation of the battery.

Engine

1. Drain the engine oil from the oil pan and install the drain plug.
2. Remove and discard the oil filter. Install a new oil filter.
3. Refill the oil pan with 10 qts (9.5 l) of SAE 15W-40 CH-4, CI-4, or higher motor oil.
4. Start the engine and run it at idle speed for approximately two minutes.
5. Stop the engine.
6. Flush the fuel tank with fresh, clean diesel fuel.
7. Secure all of the fuel system fittings.
8. Thoroughly clean and service the air cleaner assembly.
9. Seal the air cleaner inlet and the exhaust outlet with weatherproof tape.
10. Check the anti freeze protection and add a 50/50 solution of water and ethylene glycol anti-freeze as needed for the expected minimum temperature in your area.

Schematics

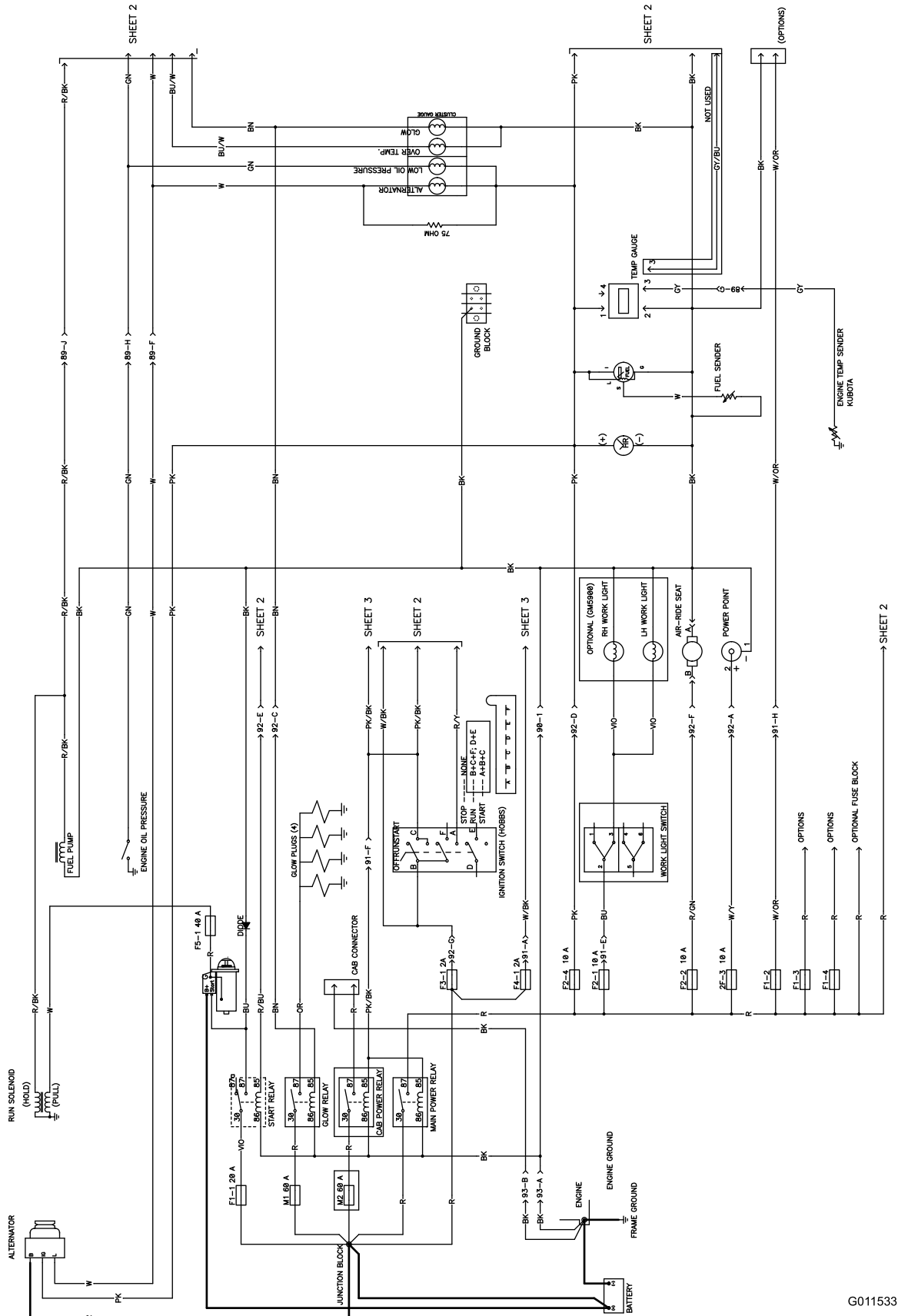

Electrical Schematic (Rev. D)

G011533

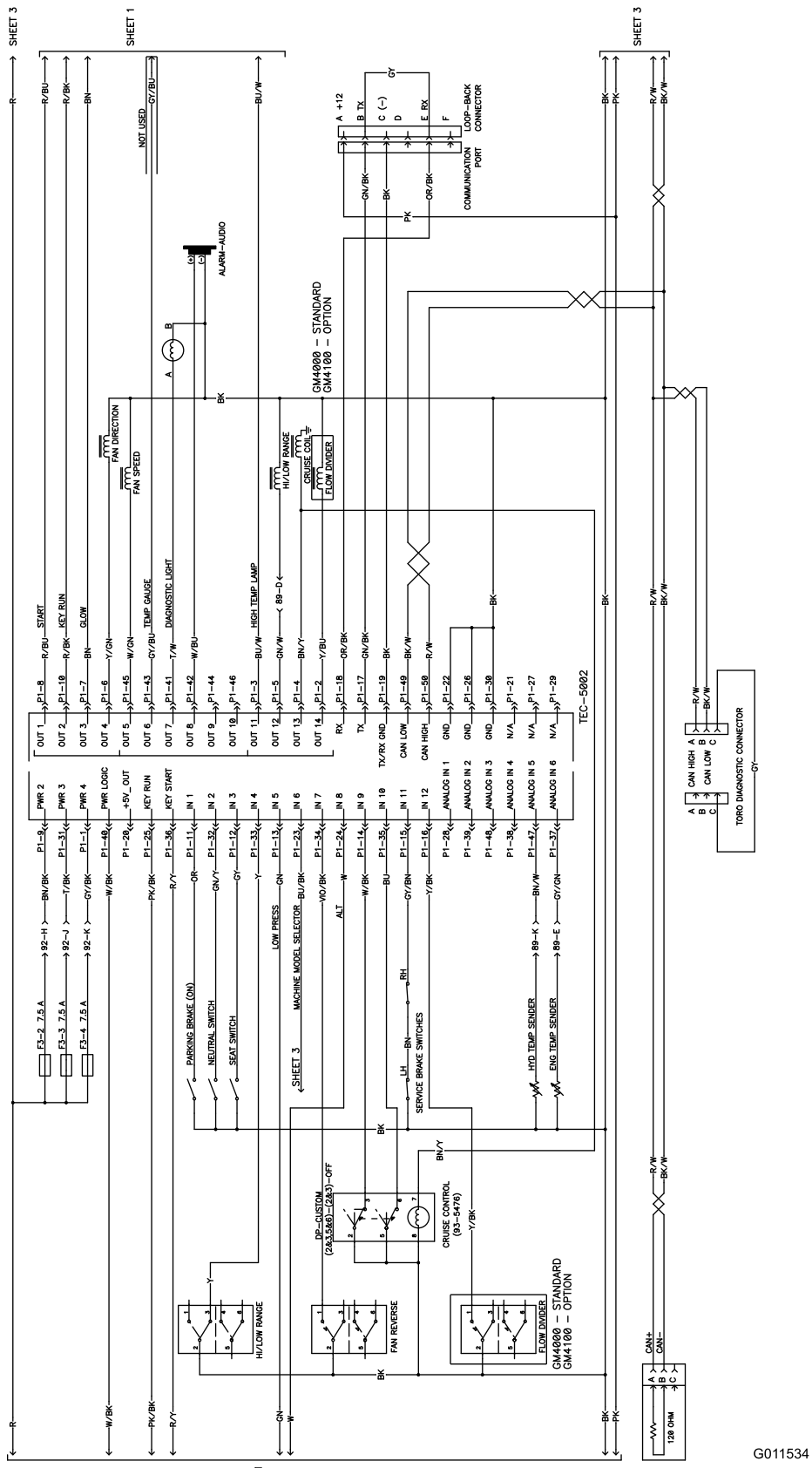

Electrical Schematic (Rev. D)

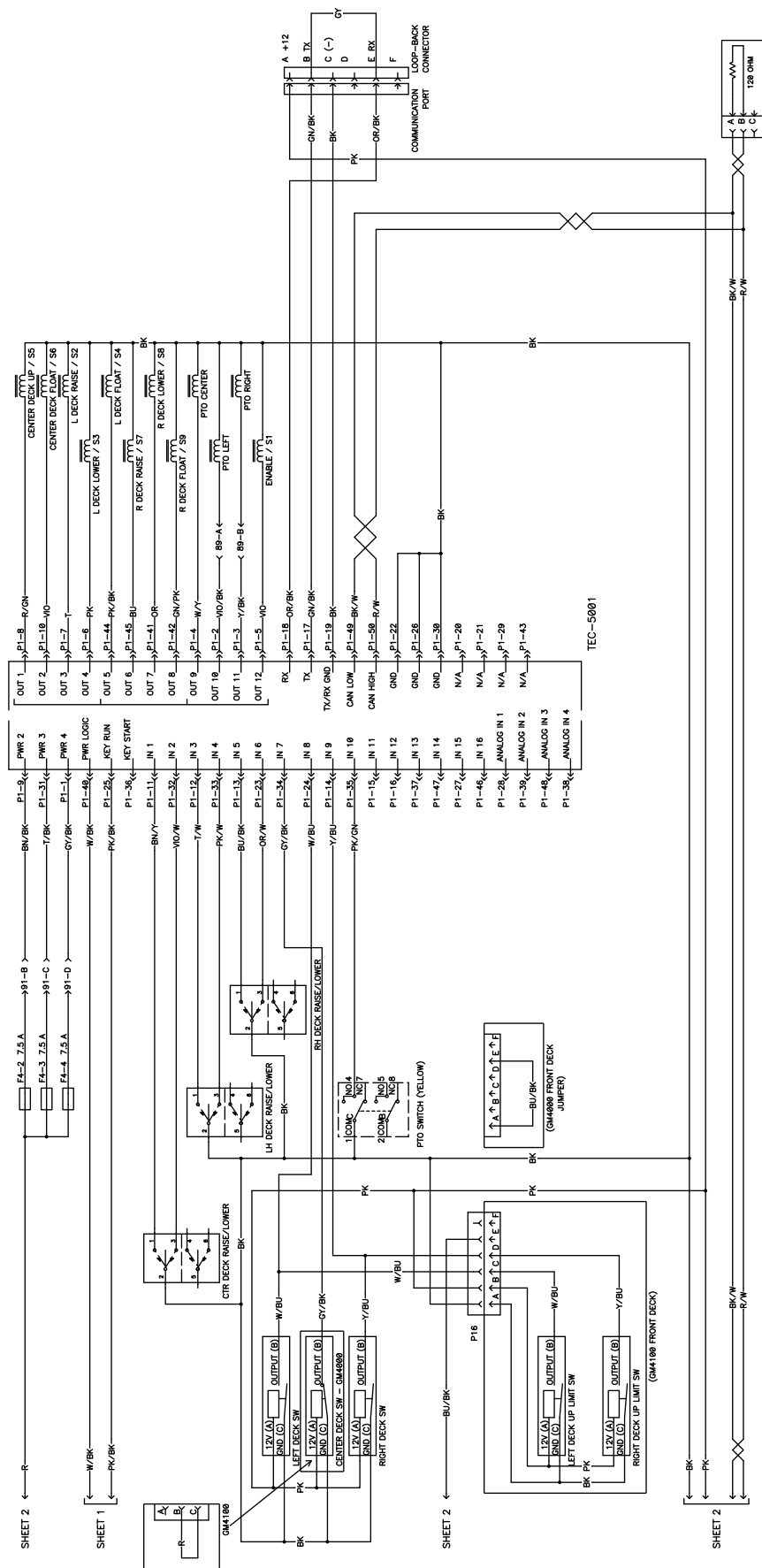

Electrical Schematic (Rev. D)

G011535

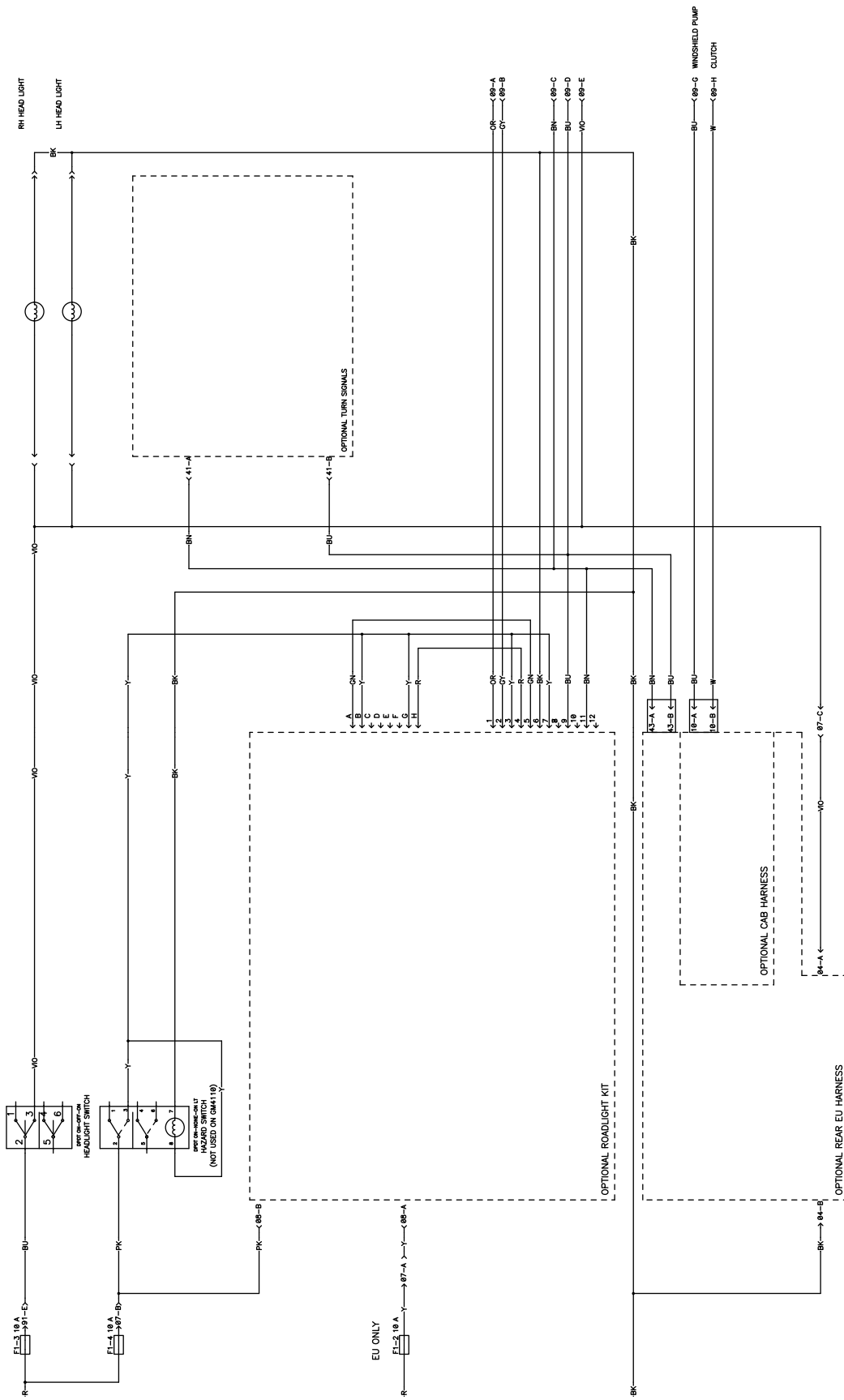

Electrical Schematic, EU-GM 4000/4100 (Rev. D)

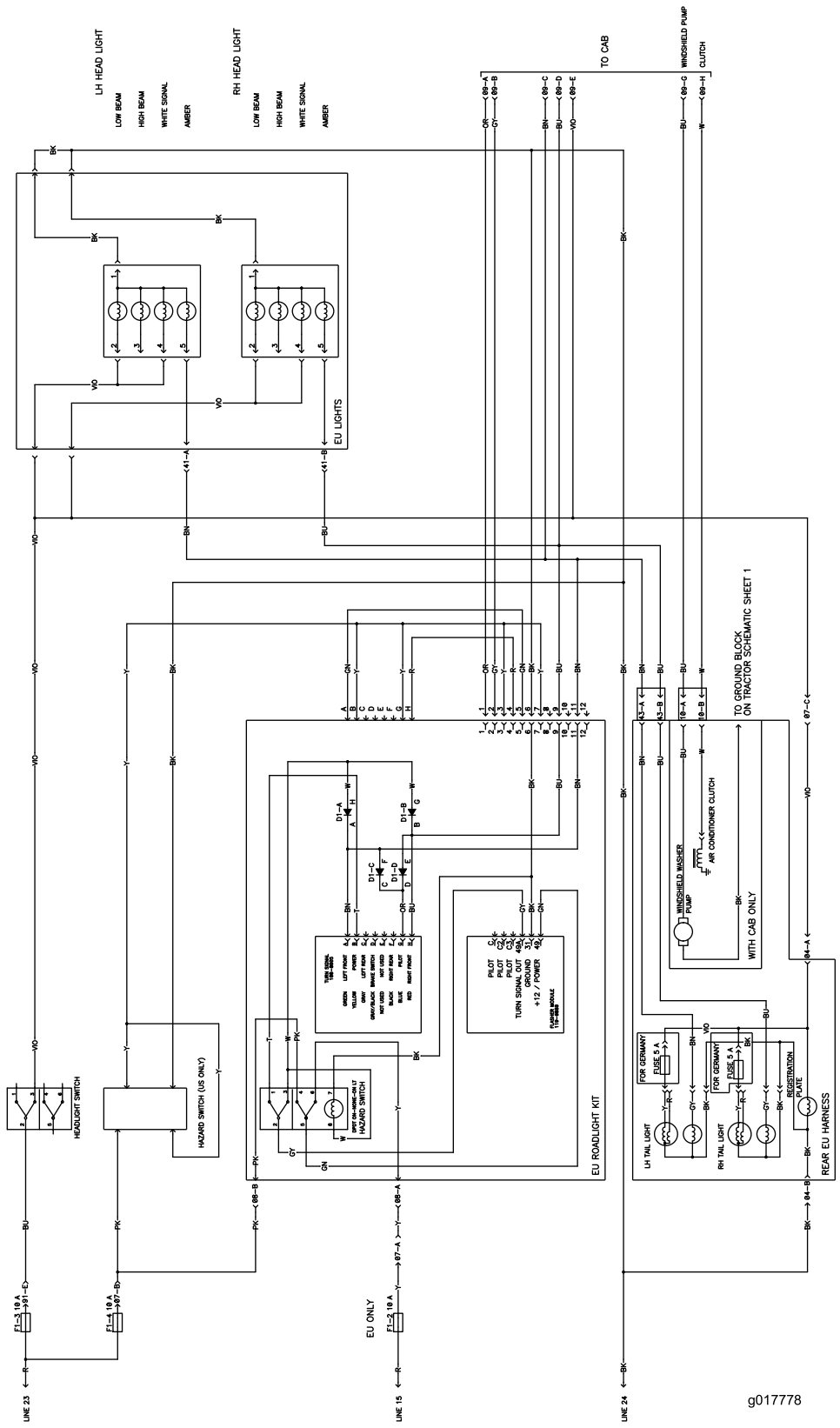

Electrical Schematic, EU-GM 4010 (Rev. D)

g017778

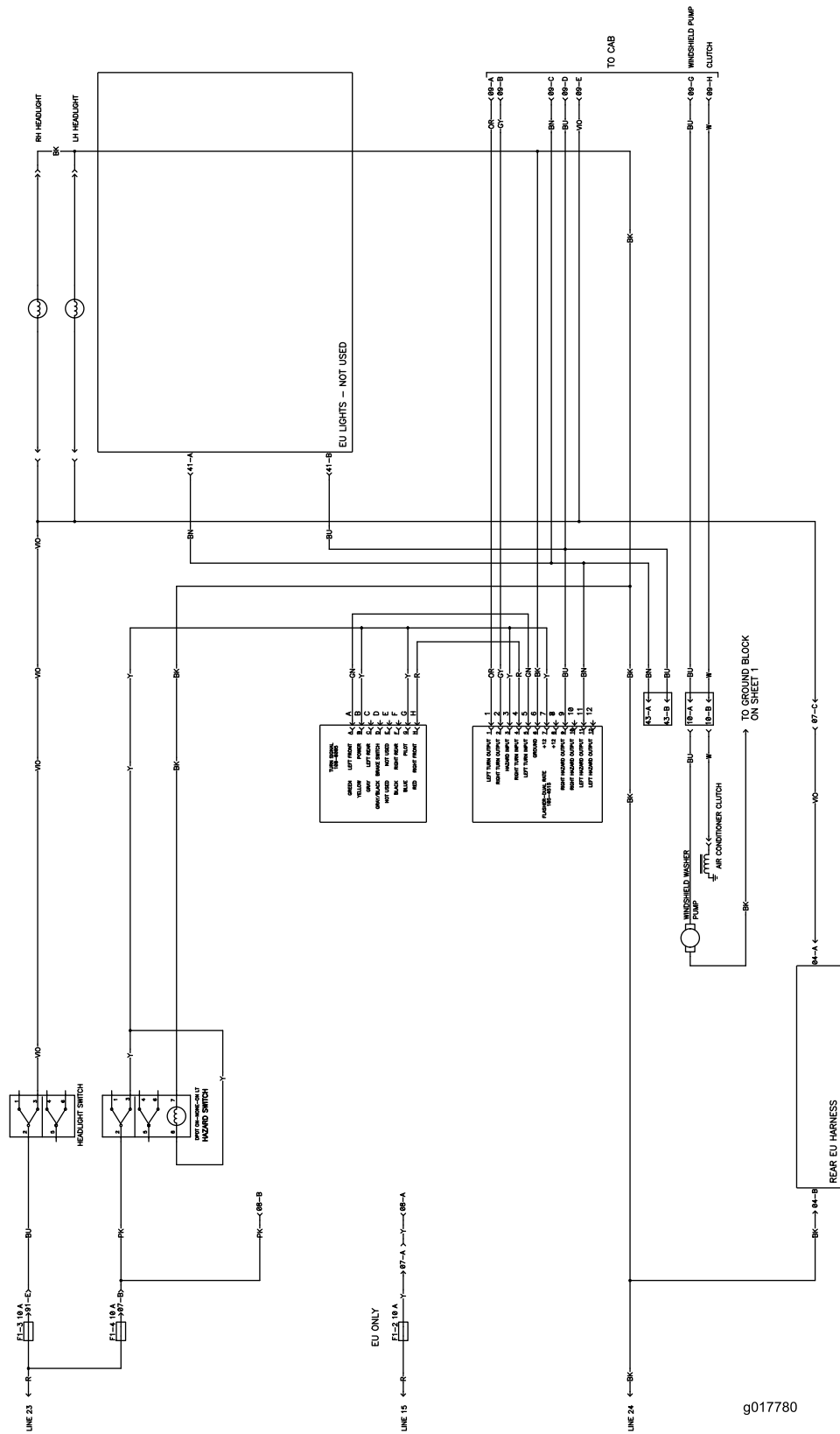

g017780

Electrical Schematic, US-GM 4010 (Rev. D)

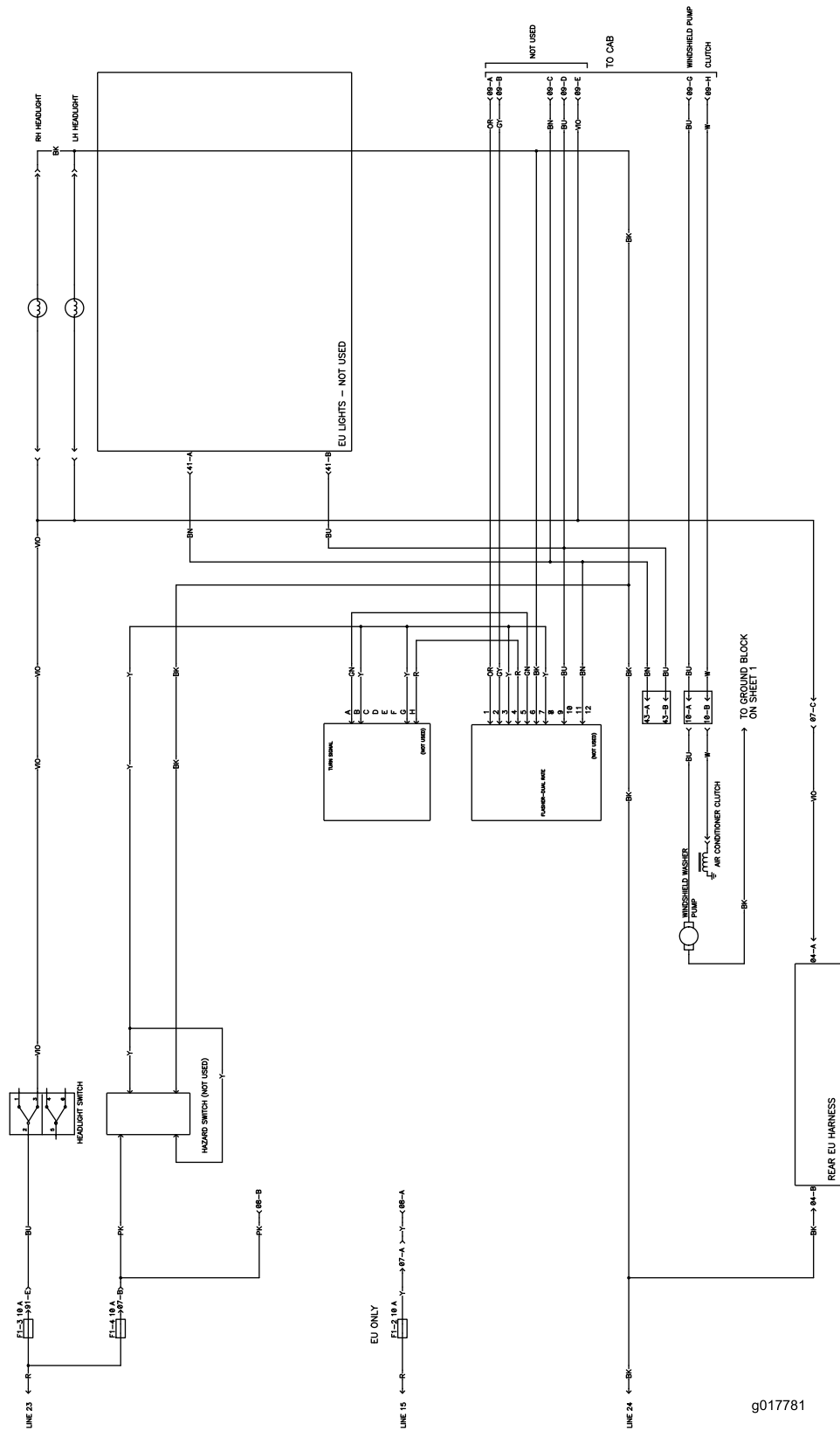

Electrical Schematic, US-GM 4110 (Rev. D)

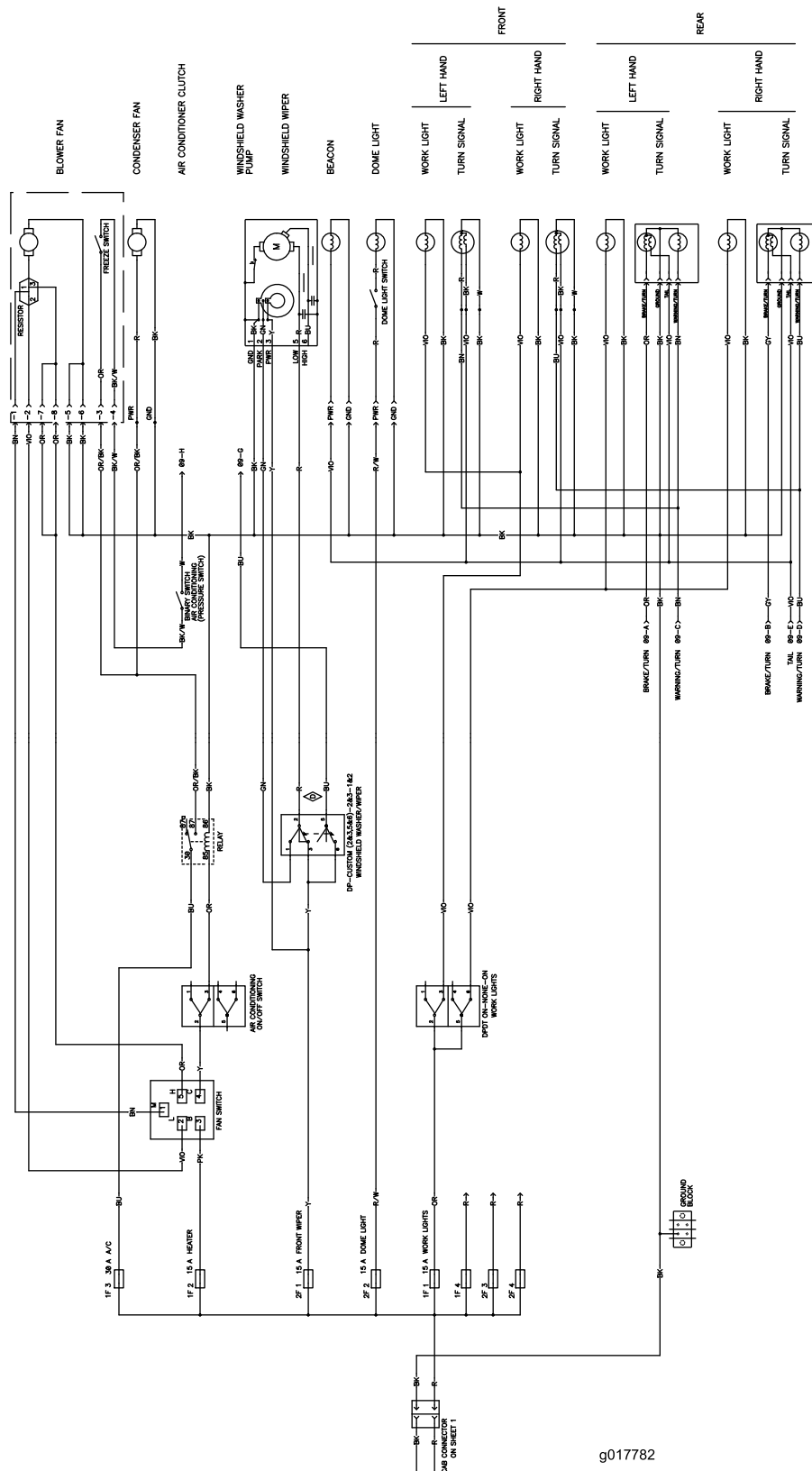

Electrical Schematic, GM 4010 (Rev. D)

g017782

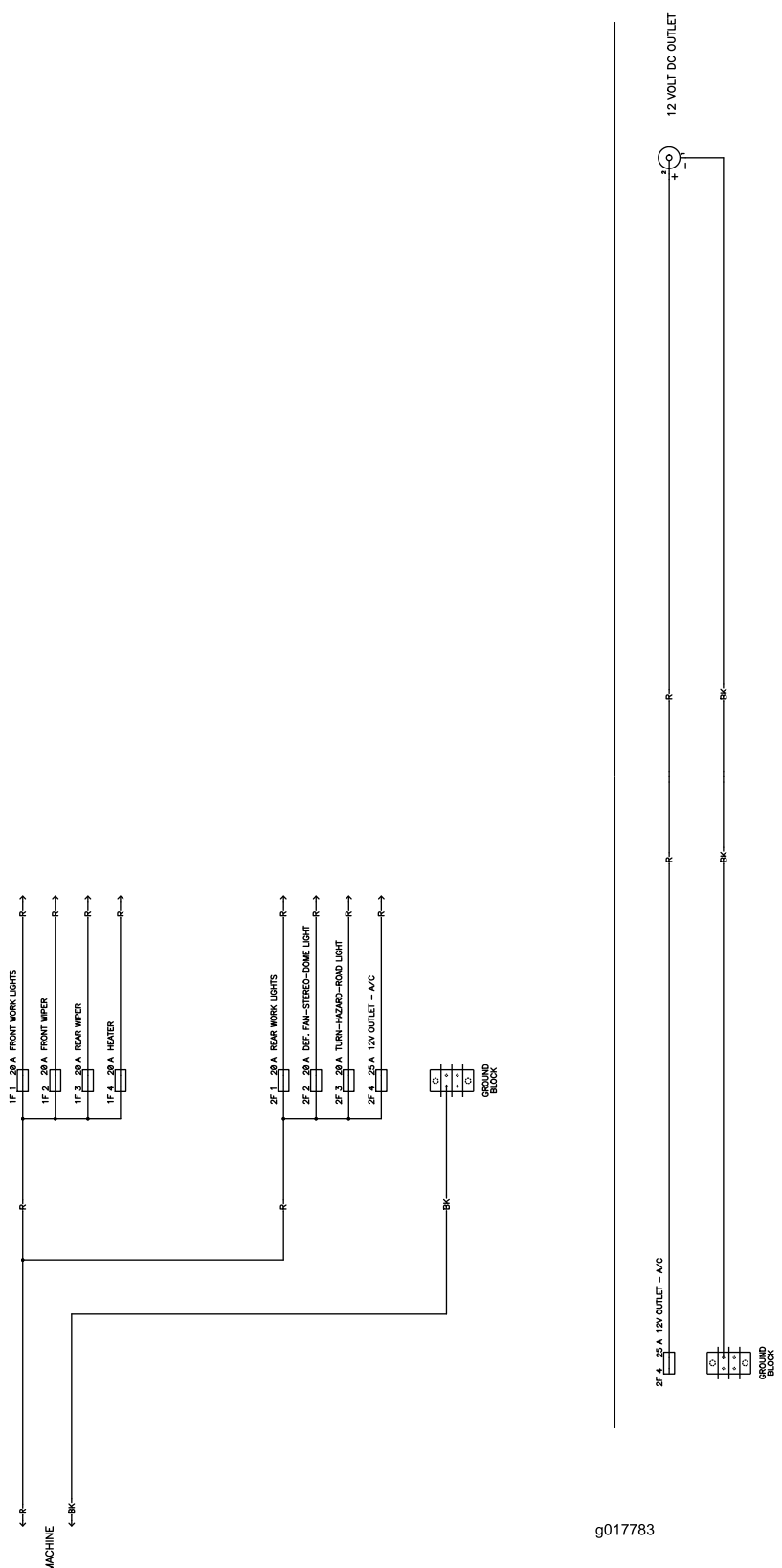

g017783

Electrical Schematic, GM 4110 (Rev. D)

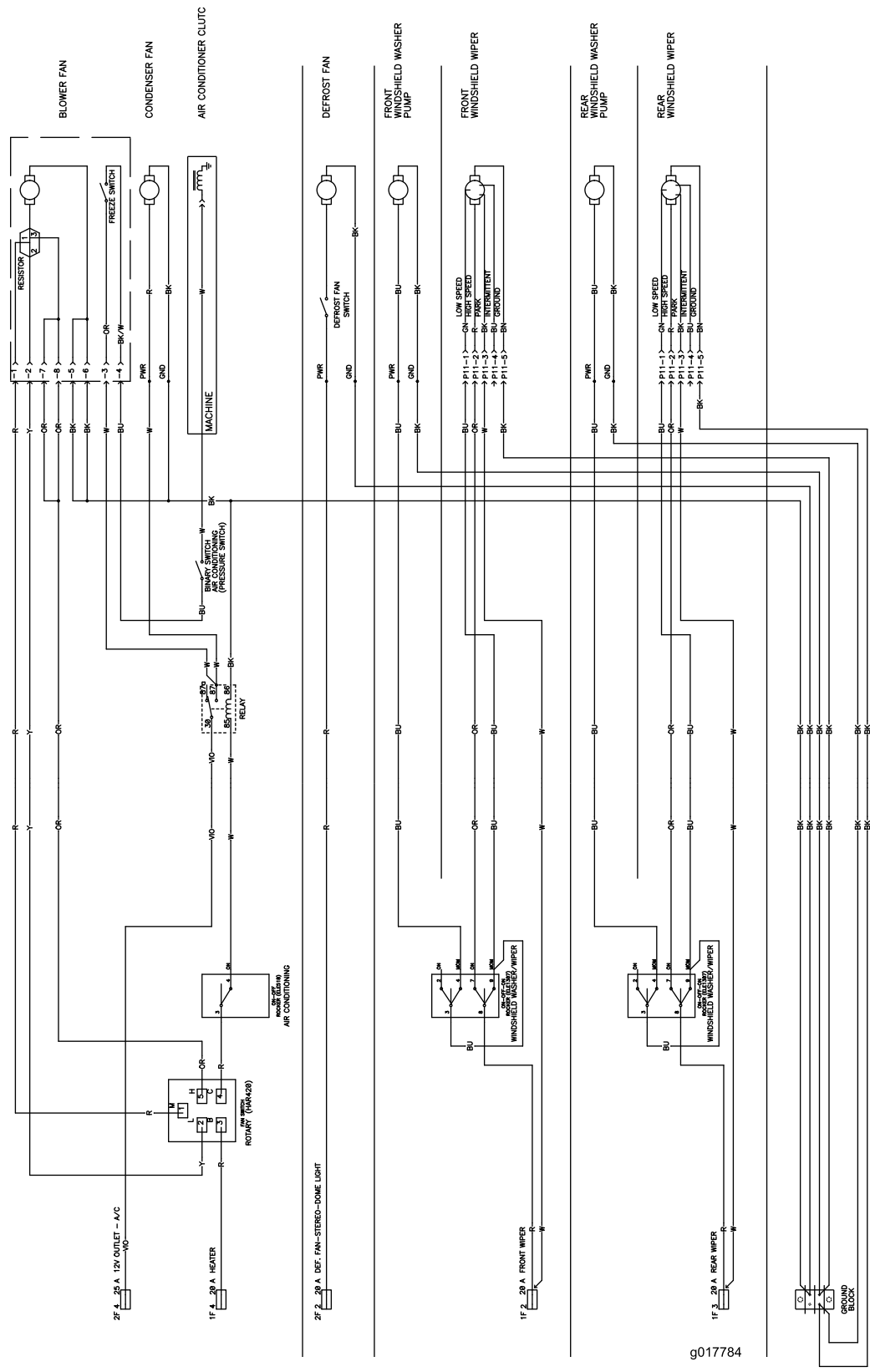

g017784

Electrical Schematic, GM 4110 Cab (Rev. D)

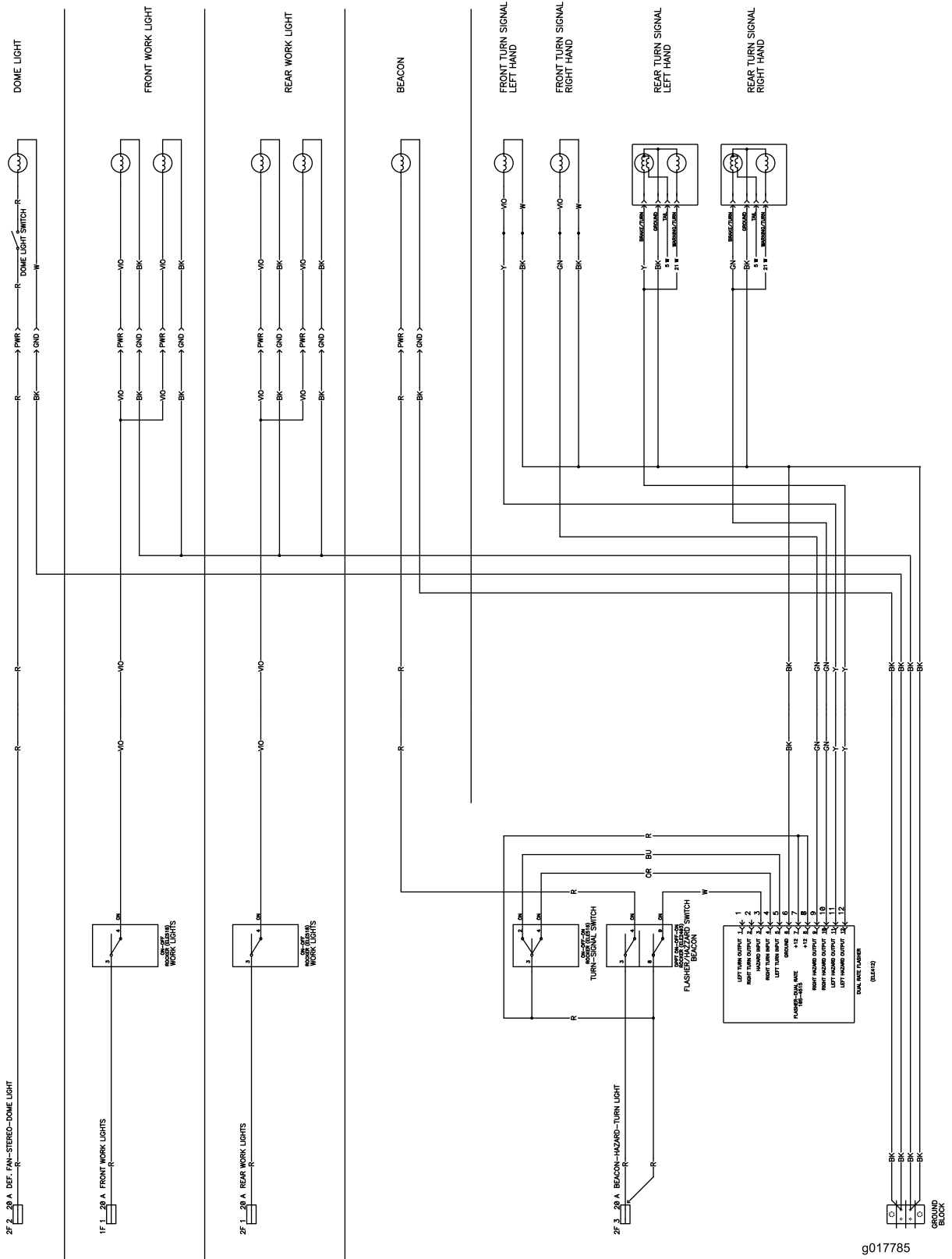

Electrical Schematic, GM 4110 Cab (Rev. D)

g017785



The Toro Total Coverage Guarantee

A Limited Warranty

Conditions and Products Covered

The Toro Company and its affiliate, Toro Warranty Company, pursuant to an agreement between them, jointly warrant your Toro Commercial product ("Product") to be free from defects in materials or workmanship for two years or 1500 operational hours*, whichever occurs first. This warranty is applicable to all products with the exception of Aerators (refer to separate warranty statements for these products). Where a warrantable condition exists, we will repair the Product at no cost to you including diagnostics, labor, parts, and transportation. This warranty begins on the date the Product is delivered to the original retail purchaser.

* Product equipped with an hour meter.

Instructions for Obtaining Warranty Service

You are responsible for notifying the Commercial Products Distributor or Authorized Commercial Products Dealer from whom you purchased the Product as soon as you believe a warrantable condition exists. If you need help locating a Commercial Products Distributor or Authorized Dealer, or if you have questions regarding your warranty rights or responsibilities, you may contact us at:

Toro Commercial Products Service Department
Toro Warranty Company
8111 Lyndale Avenue South
Bloomington, MN 55420-1196
952-888-8801 or 800-952-2740
E-mail: commercial.warranty@toro.com

Owner Responsibilities

As the Product owner, you are responsible for required maintenance and adjustments stated in your *Operator's Manual*. Failure to perform required maintenance and adjustments can be grounds for disallowing a warranty claim.

Items and Conditions Not Covered

Not all product failures or malfunctions that occur during the warranty period are defects in materials or workmanship. This warranty does not cover the following:

- Product failures which result from the use of non-Toro replacement parts, or from installation and use of add-on, or modified non-Toro branded accessories and products. A separate warranty may be provided by the manufacturer of these items.
- Product failures which result from failure to perform recommended maintenance and/or adjustments. Failure to properly maintain your Toro product per the Recommended Maintenance listed in the *Operator's Manual* can result in claims for warranty being denied.
- Product failures which result from operating the Product in an abusive, negligent, or reckless manner.
- Parts subject to consumption through use unless found to be defective. Examples of parts which are consumed, or used up, during normal Product operation include, but are not limited to, brake pads and linings, clutch linings, blades, reels, rollers and bearings (sealed or greasable), bed knives, spark plugs, castor wheels and bearings, tires, filters, belts, and certain sprayer components such as diaphragms, nozzles, and check valves, etc.
- Failures caused by outside influence. Conditions considered to be outside influence include, but are not limited to, weather, storage practices, contamination, use of unapproved fuels, coolants, lubricants, additives, fertilizers, water, or chemicals, etc.
- Failure or performance issues due to the use of fuels (e.g. gasoline, diesel, or biodiesel) that do not conform to their respective industry standards.

Countries Other than the United States or Canada

Customers who have purchased Toro products exported from the United States or Canada should contact their Toro Distributor (Dealer) to obtain guarantee policies for your country, province, or state. If for any reason you are dissatisfied with your Distributor's service or have difficulty obtaining guarantee information, contact the Toro importer.

- Normal noise, vibration, wear and tear, and deterioration.
- Normal "wear and tear" includes, but is not limited to, damage to seats due to wear or abrasion, worn painted surfaces, scratched decals or windows, etc.

Parts

Parts scheduled for replacement as required maintenance are warranted for the period of time up to the scheduled replacement time for that part. Parts replaced under this warranty are covered for the duration of the original product warranty and become the property of Toro. Toro will make the final decision whether to repair any existing part or assembly or replace it. Toro may use remanufactured parts for warranty repairs.

Deep Cycle and Lithium-Ion Battery Warranty:

Deep cycle and Lithium-Ion batteries have a specified total number of kilowatt-hours they can deliver during their lifetime. Operating, recharging, and maintenance techniques can extend or reduce total battery life. As the batteries in this product are consumed, the amount of useful work between charging intervals will slowly decrease until the battery is completely worn out. Replacement of worn out batteries, due to normal consumption, is the responsibility of the product owner. Battery replacement may be required during the normal product warranty period at owner's expense. Note: (Lithium-Ion battery only): A Lithium-Ion battery has a part only prorated warranty beginning year 3 through year 5 based on the time in service and kilowatt hours used. Refer to the *Operator's Manual* for additional information.

Maintenance is at Owner's Expense

Engine tune-up, lubrication, cleaning and polishing, replacement of filters, coolant, and completing recommended maintenance are some of the normal services Toro products require that are at the owner's expense.

General Conditions

Repair by an Authorized Toro Distributor or Dealer is your sole remedy under this warranty.

Neither The Toro Company nor Toro Warranty Company is liable for indirect, incidental or consequential damages in connection with the use of the Toro Products covered by this warranty, including any cost or expense of providing substitute equipment or service during reasonable periods of malfunction or non-use pending completion of repairs under this warranty. Except for the Emissions warranty referenced below, if applicable, there is no other express warranty. All implied warranties of merchantability and fitness for use are limited to the duration of this express warranty.

Some states do not allow exclusions of incidental or consequential damages, or limitations on how long an implied warranty lasts, so the above exclusions and limitations may not apply to you. This warranty gives you specific legal rights, and you may also have other rights which vary from state to state.

Note regarding engine warranty:

The Emissions Control System on your Product may be covered by a separate warranty meeting requirements established by the U.S. Environmental Protection Agency (EPA) and/or the California Air Resources Board (CARB). The hour limitations set forth above do not apply to the Emissions Control System Warranty. Refer to the Engine Emission Control Warranty Statement supplied with your product or contained in the engine manufacturer's documentation for details