



MODEL NO. 30455TS- 70001 thru
80001 & UP

OPERATOR'S
MANUAL

GROUNDMASTER® 455 D
TRACTION UNITS & CUTTING UNIT

To understand this product, and for safety and optimum performance, read this manual before starting the engine. Pay special attention to **SAFETY INSTRUCTIONS** highlighted by this symbol.



It means **CAUTION, WARNING** or **DANGER** – personal safety instruction. Failure to comply with the instruction may result in personal injury.



The GROUNDMASTER 455-D conforms to the American National Standards Institute's safety standards for riding mowers when standard rear weight ballast is installed: thus, TORO proudly displays the ANSI safety seal.



FOREWORD

This operator's manual has instructions on safety, proper set-up and operation, adjustments and maintenance. Therefore, anyone involved with the product, including the operator, should read and understand this manual. Major sections are:

- Safety Instructions
- Before Operating
- Operating Instructions
- Maintenance
- Schematics
- Seasonal Storage

This manual emphasizes safety, mechanical and general product information. **DANGER**, **WARNING** and **CAUTION** identify safety messages. Whenever the triangular safety alert symbol appears, understand the safety message that follows. For complete safety instructions, read pages 4 – 5. **IMPORTANT** highlights special mechanical information and **NOTE** emphasizes general product information worthy of special attention.

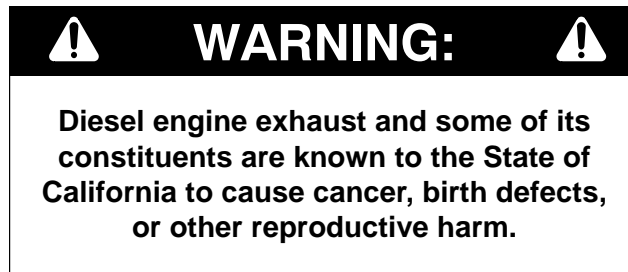

OPTIONAL SPARK ARRESTER

In some places a spark arrester muffler must be used because of local, state or federal regulations. The spark arrester available from your local Toro Distributor is approved by the United States Department of Agriculture and the United States Forest Service. If a spark arrester muffler is required, order the following part from your Authorized Toro Distributor:

- (1) 94–5637 Spark Arrester Muffler

When the mower is used or operated on any California forest, brush or grass covered land, a properly operating spark arrester must be attached to the muffler. The operator is violating state law, Section 442 Public Resources Code if a spark arrester is not used.

Whenever you have questions or need service, contact your local authorized Toro Distributor. In addition to having a complete line of accessories and professional turf care service technicians, the distributor has a complete line of genuine TORO replacement parts to keep your machine operating properly. Keep your TORO all TORO. Buy genuine TORO parts and accessories.

IDENTIFICATION AND ORDERING

MODEL AND SERIAL NUMBER

The model and serial number for the traction unit is on a plate that is mounted on the left front frame member. Use model and serial number in all correspondence and when ordering parts.

To order replacement parts from an authorized TORO Distributor, supply the following information:

1. Model and serial numbers of the machine.
2. Part number, description and quantity of parts desired.

Note: Do not order by reference number if a parts catalog is being used; use the part number.

TABLE OF CONTENTS

PRODUCT IDENTIFICATION	2	Servicing Air Cleaner Filter	21
TABLE OF CONTENTS	3	ENGINE MAINTENANCE	22
SAFETY INSTRUCTIONS	4	Engine and Oil Filter	22
SAFETY AND INSTRUCTION DECALS	6	Fuel System	22
SPECIFICATIONS	8	Engine Cooling System	23
LOOSE PARTS CHART	9	Engine Fan Belt	23
BEFORE OPERATING	9	Engine Timing Belt	24
Check Engine Oil	9	HYDRAULIC MAINTENANCE	24
Check Cooling System	9	Changing Hydraulic Oil	24
Fill Fuel Tank	10	Replacing Hydraulic Filter	25
Check Hydraulic Circuit Oil	10	Checking Hydraulic Lines and Hoses	25
Check Front Axle Oil Level	11	Hydraulic System Test Ports	25
Check Rear Axle Lubricant	11	Adjusting Traction Drive for Neutral	26
Check Tire Pressure	11	HYDRAULIC SCHEMATIC	27
Check Torque of Wheel Nuts	11	AXLE MAINTENANCE	28
KNOW YOUR CONTROLS	12	Changing Front Axle Lubricant	28
OPERATING INSTRUCTIONS	13	Changing Rear Axle Lubricant	28
Starting and Stopping	13	Rear Wheel Toe-In	28
Priming / Bleeding Fuel System	13	BRAKE MAINTENANCE	29
Checking Interlock System	14	Adjusting Service Brakes	29
Operating Characteristics	14	P.T.O. MAINTENANCE	29
Operating Tips	15	Adjusting P.T.O. Belt	29
SERVICE INTERVAL CHARTS	16	Adjusting Clutch	29
LUBRICATION	17	ELECTRICAL MAINTENANCE	30
Greasing	17	Battery Care	30
DAILY MAINTENANCE CHECKLIST	19	Fuses	30
MAINTENANCE SCHEDULE	20	ELECTRICAL SCHEMATIC	30
AIR CLEANER MAINTENANCE	21	PREPARATION FOR SEASONAL STORAGE ...	31
General Maintenance Practices	21	THE TORO PROMISE	32



SAFETY INSTRUCTIONS

The **GROUNDMASTER 455-D** was tested and certified by **TORO** for compliance with the **B71.4-1990** specifications of the **American National Standards Institute**. Although hazard control and accident prevention partially are dependent upon the design and configuration of the machine, these factors are also dependent upon the awareness, concern, and proper training of the personnel involved in the operation, transport, maintenance, and storage of the machine. Improper use or maintenance of the machine can result in injury or death. To reduce the potential for injury or death, comply with the following safety instructions.

BEFORE OPERATING

1. Read and understand the contents of this manual before starting and operating the machine. Become familiar with the controls and know how to stop the machine and engine quickly. A free replacement manual is available by sending the complete model and serial number to:

The Toro Company
8111 Lyndale Avenue South
Minneapolis, Minnesota 55420.

2. Never allow children to operate the machine. Do not allow adults to operate machine without proper instruction. Only trained operators who have read this manual should operate this machine.

3. Never operate the machine when under the influence of drugs or alcohol.

4. Keep all shields, safety devices and decals in place. If a shield, safety device or decal is defective, illegible or damaged, repair or replace it before operating the machine. Also tighten any loose nuts, bolts or screws to ensure machine is in safe operating condition.

5. Always wear substantial shoes. Do not operate machine while wearing sandals, tennis shoes, sneakers or when barefoot. Do not wear loose fitting clothing that could get caught in moving parts and possibly cause personal injury. Wearing safety glasses, safety shoes, long pants and a helmet is advisable and required by some local ordinances and insurance regulations.

6. Assure interlock switches are adjusted correctly so engine cannot be started unless traction pedal is in **NEUTRAL** and cutting unit is **DISENGAGED**.

7. Remove all debris or other objects that might be picked up and thrown by the blades or fast moving components from other attached implements. Keep all bystanders away from operating area.

8. Since diesel fuel is highly flammable, handle it carefully:

- A. Use an approved fuel container.

B. Do not remove fuel tank cap while engine is hot or running.

C. Do not smoke while handling fuel.

D. Fill fuel tank outdoors and only to within an inch from the top of the tank, not the filler neck. Do not overfill.

E. Wipe up any spilled fuel.

WHILE OPERATING

9. Sit on the seat when starting and operating the machine.

10. Before starting the engine:

A. Engage the parking brake.

B. Make sure traction pedal is in **NEUTRAL** and cutting decks are **DISENGAGED**. Move axle shift to **HI** or **LO** position.

C. After engine is started, release parking brake and keep foot off traction pedal. Machine must not move. If movement is evident, the neutral return mechanism is adjusted incorrectly; therefore, shut engine off and adjust until machine does not move when traction pedal is released. Refer to **Adjusting Traction Drive for Neutral**, page 30.

11. Seating capacity is one person. Therefore, never carry passengers.

12. Do not run engine in a confined area without adequate ventilation. Exhaust fumes are hazardous and could possibly be deadly.

13. Check interlock switches daily for proper operation. Do not rely entirely on safety switches - use common sense. If a switch fails, replace it before operating the machine. The interlock system is for your protection, so do not bypass it. Replace all interlock switches every two years.

14. Using the machine demands attention and to prevent loss of control:

A. Operate only in daylight or when there is good artificial light.

B. Drive slowly. Avoid sudden stops and starts.

C. Watch for holes or other hidden hazards.

D. Look behind machine before backing up.

E. Do not drive close to a sand trap, ditch, creek or other hazard.

F. Reduce speed when making sharp turns and turning on a hillside.

15. Traverse slopes carefully. Do not start or stop suddenly when traveling uphill or downhill. Never shift axle when moving. Machine must be on a flat surface and / or brakes must be engaged to prevent freewheeling.



SAFETY INSTRUCTIONS

16. Operator must be skilled and trained in how to drive on hillsides. Failure to use caution on slopes or hills may cause loss of control and vehicle to tip or roll possibly resulting in personal injury or death.
17. This product may exceed noise levels of 85 dB(A) at the operator position. Ear protectors are recommended, for prolonged exposure, to reduce the potential of permanent hearing damage.
18. When operating 4 wheel drive machine, always use the seat belt and ROPS together and have seat pivot retaining pin installed.
19. If engine stalls or loses headway and cannot make it to the top of a slope, do not turn machine around. Always back slowly straight down the slope.
20. Raise cutting decks and latch securely in transport position before driving from one work area to another.
21. **DON'T TAKE AN INJURY RISK!** When a person or pet appears unexpectedly in or near the mowing area, **STOP MOWING**. Careless operation, combined with terrain angles, ricochets, or improperly positioned guards can lead to thrown object injuries. Do not resume mowing until area is cleared.
22. Do not touch engine, muffler or exhaust pipe while engine is running or soon after it is stopped. These areas could be hot enough to cause burns.
23. If cutting deck strikes a solid object or vibrates abnormally, stop immediately, turn engine off, set parking brake and wait for all motion to stop. Inspect for damage. If damaged, repair or replace any components before operating.
24. Before getting off the seat:
 - A. Set parking brake.
 - B. Move traction pedal to neutral and axle shift to HI or LO position.
 - C. Disengage cutting decks and wait for blades to stop.
 - D. Stop engine and remove key from switch.
 - E. Do not park on slopes unless wheels are chocked or blocked.
25. Use only a rigid tow bar if it becomes necessary to tow machine. Use trailer for normal transport.
26. Before servicing or making adjustments, stop engine and remove key from the switch.
27. Make sure machine is in safe operating condition by keeping all nuts, bolts and screws tight.
28. Make sure all hydraulic line connectors are tight, and all hydraulic hoses and lines are in good condition before applying pressure to the system.
29. Keep body and hands away from pin hole leaks or nozzles that eject high pressure hydraulic fluid. Use cardboard or paper to find hydraulic leaks. Hydraulic fluid escaping under pressure can penetrate skin and cause injury. Fluid accidentally injected into the skin must be surgically removed within a few hours by a doctor familiar with this form of injury or gangrene may result.
30. Before disconnecting or performing any work on the hydraulic system, all pressure in system must be relieved by lowering cutting units to the ground and stopping engine.
31. If major repairs are ever needed or assistance is desired, contact an Authorized Toro Distributor.
32. To reduce potential fire hazard, keep engine area free of excessive grease, grass, leaves and dirt. Clean protective screen on back of machine frequently. Never wash a warm engine or electrical connections with water.
33. If engine must be running to perform maintenance or an adjustment, keep hands, feet, clothing and other parts of the body away from cutting units and other moving parts. Keep all bystanders away.
34. Do not overspeed the engine by changing governor setting. To assure safety and accuracy, have an Authorized Toro Distributor check maximum engine speed.
35. Shut engine off before checking or adding oil to the crankcase.
36. Disconnect battery before servicing the machine. If battery voltage is required for troubleshooting or test procedures, temporarily connect the battery.
37. At the time of manufacture, the machine conformed to the safety standards for riding mower. Ballast weight, mounted to rear of traction unit, is required for machine to conform to safety standard. **DO NOT** remove ballast weight at any time. To assure optimum performance and continued safety certification of the machine, use genuine Toro replacement parts and accessories. Replacement parts and accessories made by other manufacturers may result in non-conformance with the safety standards, and the warranty may be voided.

MAINTENANCE

26. Before servicing or making adjustments, stop engine and remove key from the switch.



SAFETY AND INSTRUCTION DECALS

The following safety and instruction decals are affixed to the traction unit. If any decal becomes illegible or damaged, install a new decal. Part numbers are listed below and in your Parts Catalog.

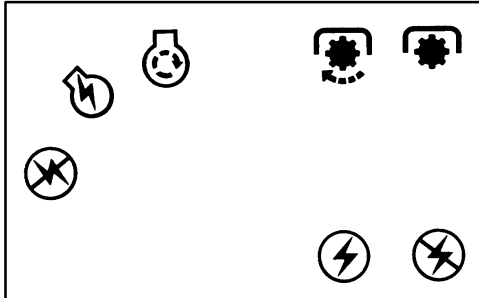

ON RIGHT HAND CONSOLE
(Part No. 84-1450)
Key Switch – Off, On & Start;
Cutting Unit Engagement Switch
– Stop & Start

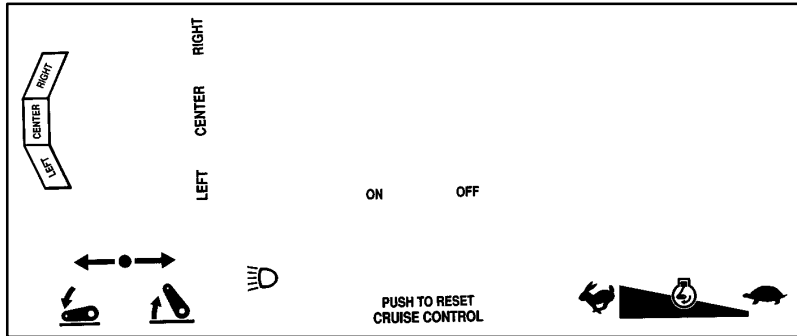

ON RIGHT HAND CONSOLE
(Part No. 86-5410)
Cutting Deck Lift Controls – Raise & Lower
Throttle Control – Increase or Decrease Speed
Light Switch – Optional
Cruise Control – Optional



ON FAN SHROUD
(Part No. 76-8750)
Keep Hands Away From Rotating Fan



ON ACCESS PANEL & FUEL TANK SUPPORT (MODEL 30455 ONLY), ALSO ON CUTTING DECK GEAR BOX SUPPORT
(Part No. 70-2560)
Gear Lube Requirements

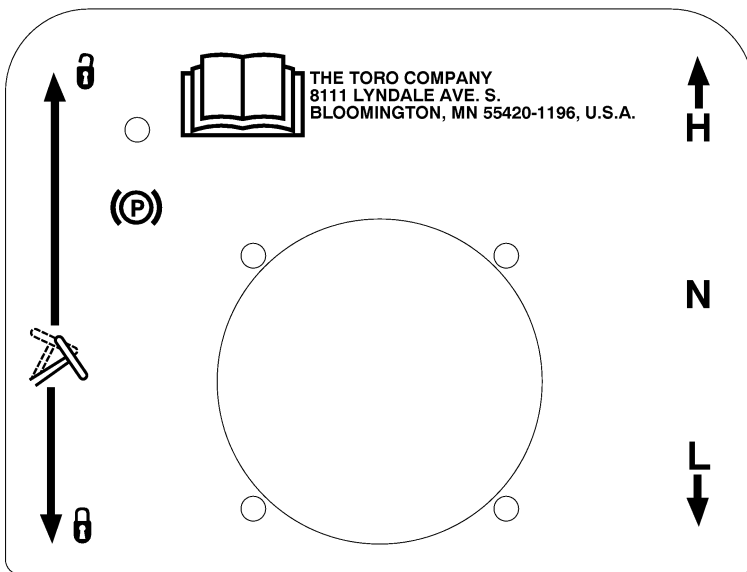

ON TOWER
(Part No. 93-9415)
Steering Wheel Tilt – Lock & Unlock
Parking Brake Latch – Engage
Ground Speed Selector – Hi, N & LO

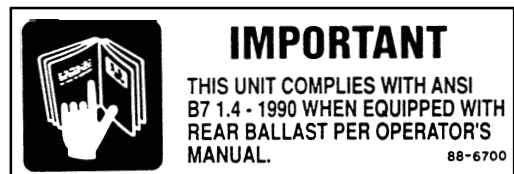

ON LEFT FRONT FRAME MEMBER
(Part No. 88-6700)
ANSI Requirements

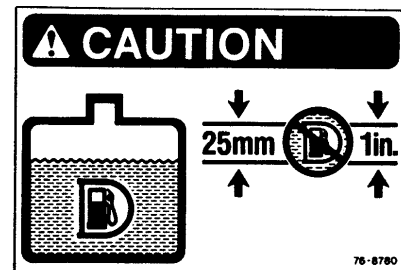

ON FUEL SPLASH GUARD
(Part No. 76-8780)
Fill Fuel Tank To No More Than
than One Inch Below Bottom Of Filler Neck
With No. 2 Diesel Fuel.



SAFETY AND INSTRUCTION DECALS

**GM 455-D 4WD
QUICK REFERENCE AID**

CHECK/SERVICE

- ENGINE OIL LEVEL/FILL
- HYDRAULIC OIL LEVEL/FILL
- FRONT AXLE OIL LEVEL/FILL
- REAR AXLE OIL
 - FILL
 - CHECK (2)
- COOLANT LEVEL/FILL
- FUEL-DIESEL ONLY
- GREASE POINTS (23)
- RADIATOR SCREEN
- AIR FILTER SERVICE INDICATOR
- WATER SEPARATOR/FUEL FILTER
 - FILL
 - CHECK (2)
- BATTERY
- FAN BELT
- TIRE PRESSURE (1-1.5 BAR/15-20 PSI)

FLUID SPECIFICATIONS/CHANGE INTERVALS

See operator's manual for initial changes.	FLUID TYPE		CAPACITY		CHANGE INTERVAL		FLUID	FILTER	FILTER PART NO.
	L	USA	L	USA	FLUID	FILTER			
ENGINE OIL	SAE 15W-40 CD	5	5.3 QT	100 HRS	100 HRS				74-7970 (A)
HYD. CIRCUIT OIL	Mobil DTE 26	24.6	6.5 G	800 HRS	800 HRS				86-3010 (B)
AXLE OIL	SAE 80-90 E.P.			800 HRS					
FUEL FILTER								400 HRS	76-5220 (C)
PRIMARY AIR FILTER									93-9162 (D)
SAFETY AIR FILTER									93-9163 (E)
FUEL	>32°F 0°C	NO. 2-D	53	14 GAL.	Drain and flush, 800 hours				
	<32°F 0°C	NO. 1-D							
COOLANT	93-7213 50/50 PEUGEOT ANTI-FREEZE	13.25	3.5 GAL.	Drain and flush, 1500 hours or 2 years, whichever occurs first. 93-7242					

ON RIGHT HAND CONSOLE FRONT
Part No. 93-7342
Quick Reference Aid

⚠ DANGER

TO AVOID SERIOUS INJURY OR DEATH COMPLY WITH THE FOLLOWING SAFETY INSTRUCTIONS. READ AND UNDERSTAND OPERATOR'S MANUAL BEFORE OPERATING THIS MACHINE.

LOS OPERADORES DEBEN ESTAR MUY BIEN CAPACITADOS EN UNA OPERACION SEGURA.

USE EXTREME CAUTION ON HILLS AND SLOPES.

- SEAT BELT SHOULD ALWAYS BE USED WHEN OPERATING WITH ROLL-OVER PROTECTION STRUCTURE. SEAT PIVOT RETAINING PIN MUST BE INSTALLED.
- GO SLOW AND AVOID SHARP TURNS ON SLOPES TO AVOID ROLLOVER.
- DECK MUST BE LOWERED WHEN GOING DOWN SLOPES FOR STEERING CONTROL.
- OPERATOR MUST BE SKILLED AND TRAINED IN SLOPE OPERATION.
- CARRY NO RIDERS. KEEP PEOPLE AND PETS A SAFE DISTANCE FROM MACHINE.
- LIFT AND SECURE DECK BEFORE TRANSPORTING.
- KEEP ALL GUARDS IN PLACE.
- BEFORE LEAVING OPERATOR'S POSITION:
 - MOVE TRACTION PEDAL TO NEUTRAL.
 - DISENGAGE DECK DRIVE.
 - SET PARKING BRAKE.
 - SHUT OFF ENGINE - REMOVE KEY.
- STOP ENGINE BEFORE ADDING FUEL OR SERVICING MACHINE.
- CHECK PERFORMANCE OF ALL INTERLOCK SWITCHES DAILY.
- BEFORE TOWING SEE OPERATOR'S MANUAL FOR INSTRUCTIONS.

84-1470

ON REAR OF TOWER
(Part No. 84-1470)*
Operating & Safety Instructions

⚠ DANGER

HIGH PRESSURE HYDRAULIC HOSES OPERATE ONLY IF THIS COVER ASSEMBLY IS IN PLACE. 93-9426

ON Access Panel
(Part No. 93-9426)
High Pressure Hydraulic Hoses

⚠ CAUTION

DO NOT USE STARTING FLUID

83-9150

ON AIR CLEANER SUPPORT
(Part No. 83-9150)
Do Not Use Starting Fluid

⚠ WARNING

DO NOT PARK ON SLOPES UNLESS WHEELS ARE CHOCKED OR BLOCKED. 92-1370

ON LEFT FLOOR PLATE
(Part No. 92-1370)
Parking Requirements

⚠ WARNING

SHIELD MISSING DO NOT USE

88-8950

ON Lower PTO Pulley
(Part No. 88-8950)
Shield Missing Do Not Use

* 84-1471 German, 84-1472 French, 84-1473 Dutch, 84-1474 Swedish, 84-1475 Spanish, 84-1476 Italian, 84-1477 Danish, 84-1478 Japanese.

SPECIFICATIONS

TRACTION UNIT

Engine: Peugeot, four-cycle, four cylinder, 1.9 liter (1900 cc) displacement, liquid cooled diesel engine. 23.5:1 compression ratio. Low idle – 1600 rpm, high idle – 3000 rpm. Oil capacity is 5.3 qts. with filter.

Cooling System: Capacity is 3.5 gal. of 50/50 mixture of Peugeot recommended anti-freeze.

Fuel System: Capacity is 14 gal. of #1 or #2 diesel fuel.

Hydraulic System: Reservoir capacity is 6.5 gal. Replaceable spin-on filter element.

Traction System: Ground speed: Low Range; 0 - 6.5 m.p.h (0 – 5.5 m.p.h. with mechanical speed limiter interlock) forward and 0 -3 reverse. High Range; 0-15 mph (0 – 12.4 m.p.h. with mechanical speed limiter interlock) forward and 0-5 mph reverse.

Front Axle: Two speed axle is designed to withstand heavy duty slope operation and side loading. Separate mowing and transport selections for faster and more efficient machine operation. Neutral position allows easy towing. Lubricated with SAE 80-90 wt. EP gear lube. Capacity is 128 oz.

Rear Axles: Two Wheel Drive – The large diameter wheel spindles are designed for durability and long wear, yet provide superior stability and maneuverability. Four Wheel Drive - Heavy duty, agricultural type. Hydraulic drive with “on demand” over running clutch and balanced weight distribution provides superior traction on hillsides. Lubricated with SAE 80-90 wt. EP gear lube. Capacity is 80 oz.

Tires/Wheels: High flotation turf tread tires on de-mountable rims. Front tires: (2) 26 x 12.0–12, 8 ply. Rear tires: (2) 20 x 10.0–10, 6 ply. Tire pressure 20 psi.

Seat: Adjustable fore and aft travel and weight.

Diagnostic System: Test ports for: Forward and reverse traction (2 wheel drive), front and rear axle motors (4 wheel drive), lift and counterbalance circuit, steering circuit and charge circuit.

Steering System: Automotive type, full power.

Brakes: Totally enclosed, non asbestos, dry multi-disc 5-5/8” individual wheel and parking brakes on front traction wheels. Brakes controlled by individual pedals operated by the left foot. Dynamic braking through closed-loop hydrostatic drive.

Electrical System: 12 volt battery with 650 cold cranking Amps @ 0 ° F. 55 amp amp alternator, ammeter, starter, key switch and automatic temperature controlled glow plug controller. Separately fused, run, deck and instrument/accessory circuits.

Interlock System: Designed to stop engine if operator gets off seat while cutting deck drive switch is engaged or traction pedal is forward or reverse. Prevents engine from starting unless traction pedal is in neutral and cutting deck is disengaged. Prevents cutting deck from operating unless axle shift is in LO range.

Warning Lights:

- Glow plug indicator
- Engine oil pressure warning
- Engine coolant temperature warning
- Charge indicator
- Water in fuel
- Low water indicator

Indicators:

- Engine coolant temperature gauge
- Fuel gauge
- Hour meter

GENERAL SPECIFICATIONS (approx.):

Overall Length:

With deck installed 134 in.

Overall Width:

Transport 75 in.
Mowing 127 in.

Height:

With ROPS installed 82in.

Wheel Tread:

(Front) 51 in.
(Rear) 41 in.

Wheel Base:

52 in.

Dry Weight:

2 Wheel Drive 3,800 lbs.
4 Wheel Drive 3,900 lbs.

OPTIONAL EQUIPMENT

Broom Kit Contact Your Local Toro Distributor

Snowthrower Contact Your Local Toro Distributor

Roll Over Protection Kit Contact Your Local Toro Distributor (Standard on Model 30455)

4 Post Canopy Kit Contact Your Local Toro Distributor

Spark Arrestor Muffler Part No. 94–5637

Segmented Wheel Kit Part No. 76–1880

Brake Light Kit Part No. 92–7763

Windshield Kit Contact Your Local Toro Distributor

Cruise Control Kit Model No. 30485

Road Light Kit Model No. 30471

Cab Contact Your Local Toro Distributor

Additional Weights Contact Your Local Toro Distributor

Low Seat Option Contact Your Local Toro Distributor

Specifications and design subject to change without notice.

LOOSE PARTS CHART

Ignition Key	1	
Operator's Manual	2	Read before operating machine.
Parts Catalog	1	
Registration Card	1	Fill out and return to Toro
Commercial Product Set-Up Card	1	

BEFORE OPERATING



CAUTION

Before servicing or making adjustments to the machine, stop engine and remove key from the switch.

CHECK ENGINE OIL (Fig. 1 & 2)

Crankcase capacity is 5.3 qt. with filter.

1. Park machine on a level surface. Release hood latch and open hood.

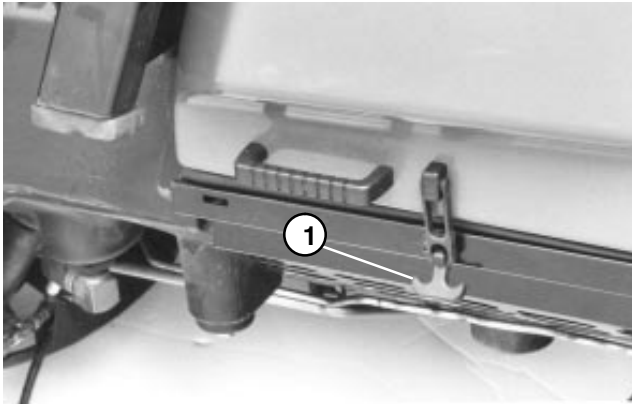

Figure 1
1. Hood Latch

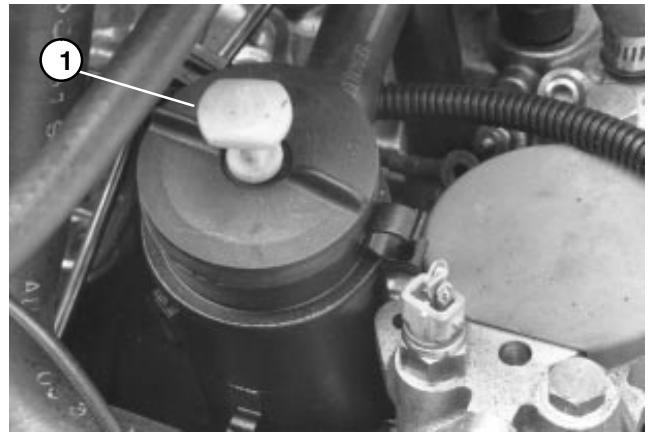

Figure 2
1. Dipstick / Tube Cap

CHECK COOLING SYSTEM (Fig. 3)

Capacity of system is 3.5 gal.

1. Park machine on a level surface. Release hood latch and open hood.
2. Check coolant level. **Coolant level should be up to or above mounting tabs on degasser tank, when engine is cold.**



Figure 3
1. Degasser Tank

2. Remove dipstick from tube cap, wipe clean and reinstall dipstick into tube cap. Pull it out again and check oil level on dipstick: Oil level must always be in notch area on dipstick.
3. If oil level is low, remove tube cap and add SAE 15W-40 CD oil until level reaches top of notch on dipstick. **DO NOT OVERFILL.**
4. Install oil tube cap.
5. Close hood and secure latch.

BEFORE OPERATING

3. If coolant is low, remove degasser tank cap and add a 50/50 mixture of water and Peugeot recommended anti-freeze (Toro Part No. 93-7213). **DO NOT USE WATER ONLY OR ALCOHOL/METHANOL BASE COOLANTS.**

IMPORTANT: Do not remove black plastic cap on degasser tank.

4. Install degasser tank cap.
5. Close hood and secure latch.

FILL FUEL TANK (Fig. 4)

1. Park machine on a level surface. Release hood latch and open hood.
2. Remove fuel tank cap.

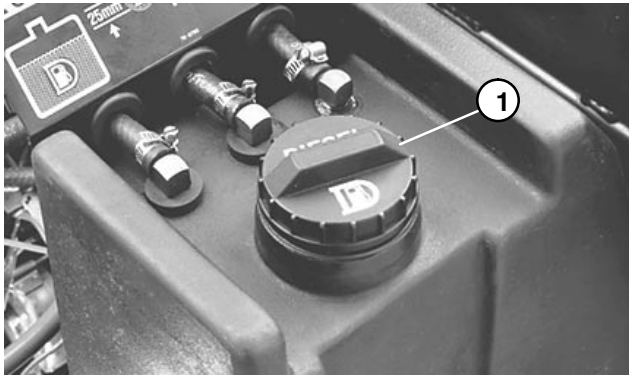

Figure 4

1. Fuel Tank Cap

3. Fill tank to no more than one inch below bottom of filler neck with No. 2 diesel fuel. **DO NOT OVER FILL.** Then install cap.

Note: For temperatures below 32° F., No. 1 diesel fuel or a blend should be used.



DANGER

Because diesel fuel is highly flammable, use caution when storing or handling it. Do not smoke while filling the fuel tank. Do not fill fuel tank while engine is running, hot, or when machine is in an enclosed area. Always fill fuel tank outside and wipe up any spilled diesel fuel before starting the engine. Store fuel in a clean, safety-approved container and keep cap in place. Use diesel fuel for the engine only; not for any other purpose.

4. Close hood and secure latch.

CHECK HYDRAULIC CIRCUIT OIL (Fig. 5)

The hydraulic system is designed to operate on Mobil DTE 26 or equivalent anti-wear hydraulic fluid. The machines reservoir is filled at the factory with approximately 6.5 gallons of fluid. However, check level of hydraulic fluid before engine is first started and daily thereafter.

Hydraulic Oil (Recommended brands):

Mobil	DTE 26
Shell	Tellus 68
Amoco	Rykon Oil #68
Conoco	Super Hydraulic Oil 68
Exxon	Nuto 68
Kendall	Kenoil R&O AW 68
Pennzoil	Penreco 68
Phillips	Magnus A 68
Standard	Energol HLP 68
Sun	Sunvis 831 WR
Union	Unax AW 68
Chevron	AW Hydraulic Oil 68

Note: All are interchangeable.

IMPORTANT: Use only hydraulic oils specified. Other fluids could cause system damage.

Note: A red dye additive for the hydraulic system oil is available in 2/3 oz. bottles. One bottle is sufficient for 4-6 gal. of hydraulic oil. Order Part No. 44-2500 from your Authorized Toro Distributor

1. Park machine on a level surface and stop engine. Make sure machine has been operated so oil is warm. Release hood latch and open hood. Check level of oil by viewing sight gauge. If oil is visible in gauge, oil level is sufficient.

2. If oil level is not visible in gauge, remove cap from hydraulic oil reservoir and slowly add Mobil DTE 26 or equivalent hydraulic oil until level reaches middle (maximum) of sight gauge. **DO NOT OVER FILL.**

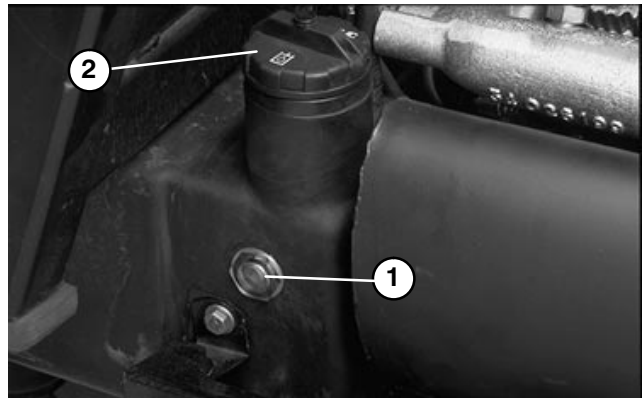

Figure 5

1. Sight Gauge 2. Hydraulic Reservoir Cap

BEFORE OPERATING

IMPORTANT: To prevent system contamination, clean top of hydraulic oil containers before puncturing. Assure pour spout and funnel are clean.

3. Install reservoir cap, close hood and secure latch.

CHECK FRONT AXLE OIL LEVEL (Fig. 6 & 7)

The front axle is shipped from the factory filled with SAE 80–90 wt. gear lube. However, check level before engine is first started and every 50 hours thereafter. Capacity is 128 oz. Check daily for signs of oil loss.

1. Park machine on a level surface.
2. Remove access panel (Fig. 6), in front of seat, to expose front axle / dipstick.

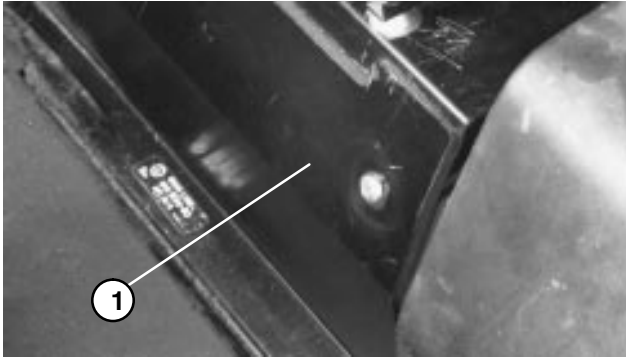

Figure 6
1. Access Panel

3. Unscrew dipstick cap (Fig. 7) from the filler neck and wipe it with a clean rag. Screw dipstick cap finger tight onto filler neck. Unscrew the dipstick and check level of lubricant. If level is not within 1/2 inch from the groove in the dipstick, add enough to raise level to groove mark. **DO NOT OVERFILL** by more than 1/2 inch above groove.

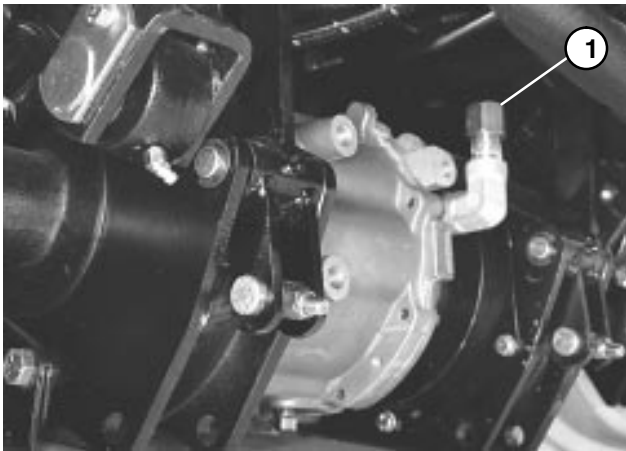

Figure 7
1. Dipstick Cap

4. Screw dipstick filler cap finger-tight onto filler neck. It is not necessary to tighten cap with a wrench.

CHECK REAR AXLE LUBRICANT (Fig. 8)

The rear axle is shipped from the factory filled with SAE 80–90 wt. gear lube. However, check level before engine is first started and every 50 hours thereafter. Capacity is 80 oz. Check daily for signs of oil loss.

1. Position the machine on a level surface.
2. Remove a check plug from one end of axle and make sure lubricant is up to bottom of hole. If level is low, remove the fill plug and add enough lubricant to bring the level up to the bottom of the check plug holes.

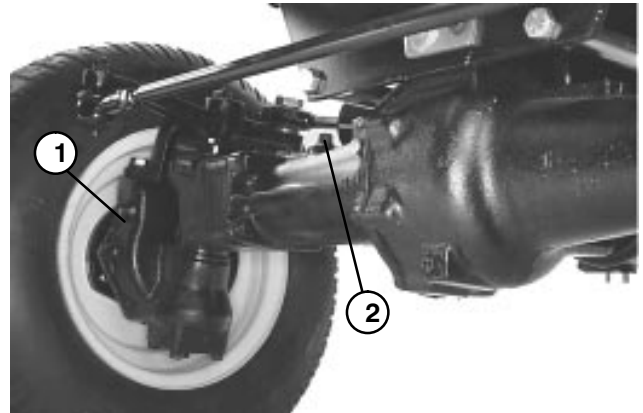

Figure 8
1. Check Plug 2. Fill Plug

CHECK TIRE PRESSURE

The tires are over-inflated for shipping. Therefore, release some of the air to reduce the pressure. Correct air pressure in the front and rear tires is 20 psi.

IMPORTANT: Maintain even pressure in all tires to assure a good quality-of-cut and proper machine performance. **DO NOT UNDER INFLATE.**

CHECK TORQUE OF WHEEL NUTS OR BOLTS



WARNING

Torque front wheel nuts to 45-55 ft-lb and rear wheel nuts or bolts to 85-100 ft-lb after 1-4 hours of operation and again after 10 hours of operation and every 200 hours thereafter. Failure to maintain proper torque could result in failure or loss of wheel and may result in personal injury.

KNOW YOUR CONTROLS

Cutting Unit Engagement Switch (Fig. 9) – Used to start and stop cutting unit operation. Lift switch and move forward to actuate cutting unit. Center deck will engage first followed by wing decks engaging approximately one second later.

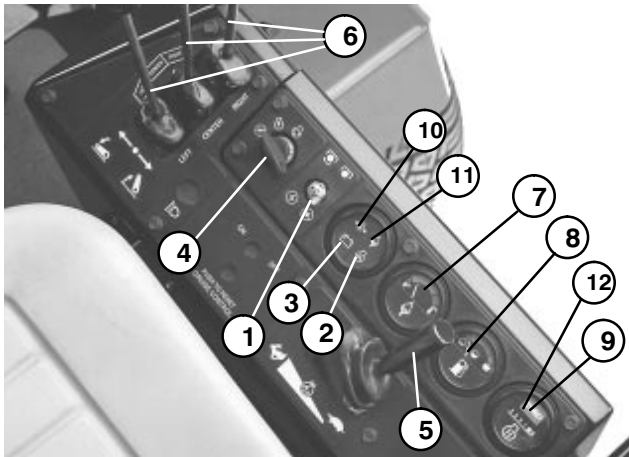

Figure 9

- | | |
|-----------------------------------|--|
| 1. Cutting Unit Engagement Switch | 8. Fuel Gauge |
| 2. Glow Plug Indicator | 9. Low Water Indicator |
| 3. Charge Indicator | 10. Engine Oil Pressure Warning Light |
| 4. Key Switch | 11. Engine Coolant Temperature Warning Light |
| 5. Throttle Control | 12. Water in Fuel Warning Light |
| 6. Cutting Unit Lift Controls | |
| 7. Coolant Temperature Gauge | |

Glow Plug Indicator (Fig.9) – Automatically actuates proper glow period when ignition key is turned to ON position. Illuminates when glow plugs are actuated. When glow plugs are heated sufficiently, light goes off indicating engine is ready to start.

Charge Indicator (Fig.9) – Illuminates when system charging circuit malfunctions.

Key Switch (Fig. 9) – Three positions: OFF, ON and START. Rotate key to START and release key when engine begins running. To stop engine, rotate key to OFF.

Throttle Control (Fig. 9) – Move control forward to increase engine speed, backward to decrease speed.

Cutting Unit Lift Controls (Fig. 9) – The two outside levers raise and lower the wing cutting units. The center lever raises and lowers the whole cutting unit. Engine must be running to lower cutting unit. When wing cutting units are raised higher than 15°, blades automatically disengage. To lower cutting unit just touch levers momentarily.

Coolant Temperature Gauge (Fig. 9) – Shows temperature of engine coolant.

Fuel Gauge (Fig. 9) – Shows amount of fuel in tank.

Low Water Indicator (Fig. 9) – Indicates low water level in cooling system.

Engine Oil Pressure Warning Light (Fig. 9) – Indicates dangerously low engine oil pressure.

Engine Coolant Temperature Warning Light (Fig. 9) – The red light illuminates and the engine stops when temperature of coolant exceeds 230°F.

Water in Fuel Indicator (Fig. 9) – Indicates when there is water in fuel.

Seat (Fig. 10) – Seat adjusting lever on left side of seat allows 4 inch fore and aft adjustment. Seat adjusting knob on front of seat, adjusts seat for operators weight.

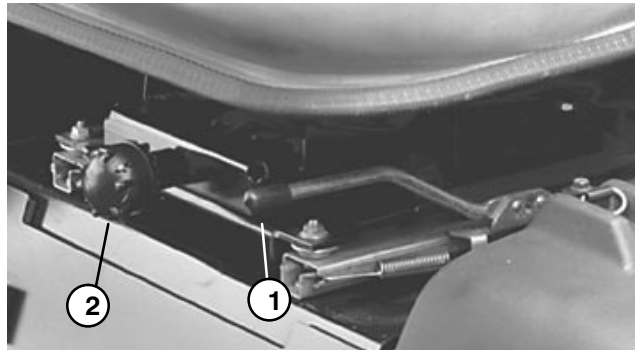

Figure 10

1. Seat Adjusting Lever 2. Seat Adjusting Knob

Traction Pedal (Fig. 11) – Controls forward and reverse operation. Depress top of pedal to move forward and bottom to move backward. Ground speed depends on how far pedal is depressed. For no load, maximum ground speed, fully depress pedal while throttle is in FAST. For maximum power under load or when going uphill, keep engine rpm high by having throttle in FAST and traction pedal partially engaged. If engine rpm begins to decrease due to load, gradually reduce traction pedal pressure until engine speed is increased.

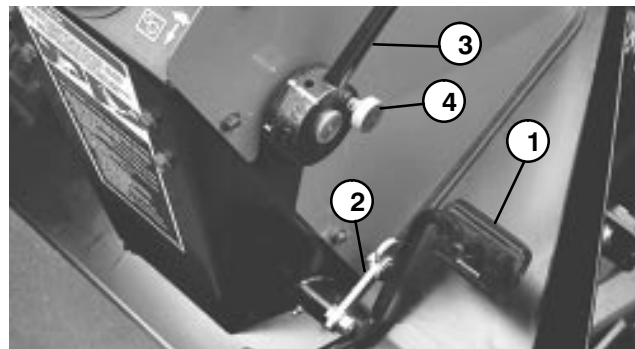

Figure 11

1. Traction Pedal 3. Axle Shift Lever
2. Speed Selector 4. Lockout Knob

To stop, reduce foot pressure on traction pedal and allow it to return to center position. On extreme downhill slopes, apply pressure to REVERSE side of pedal, or operate with heel on REVERSE and toe on FORWARD portion of pedal.

Speed Selector (Fig.11) - Cam lever at side of traction pedal can be rotated to maintain desired speed. Rotating lever forward decreases speed and backward increases speed.

KNOW YOUR CONTROLS

Axle Shift Lever (Fig.11) – Located on right side of console, lever selects front drive mode. Pull out lockout knob, move lever rearward for mowing operation and forward for transport operation, then release knob to lock selection. Lever must be in LO position to mow. Middle position (N) is for towing.

IMPORTANT: Lever must be in LO position to operate in 4-wheel drive.

CAUTION: Machine must be on a flat surface and brakes engaged when shifting axle from HI to LO position.

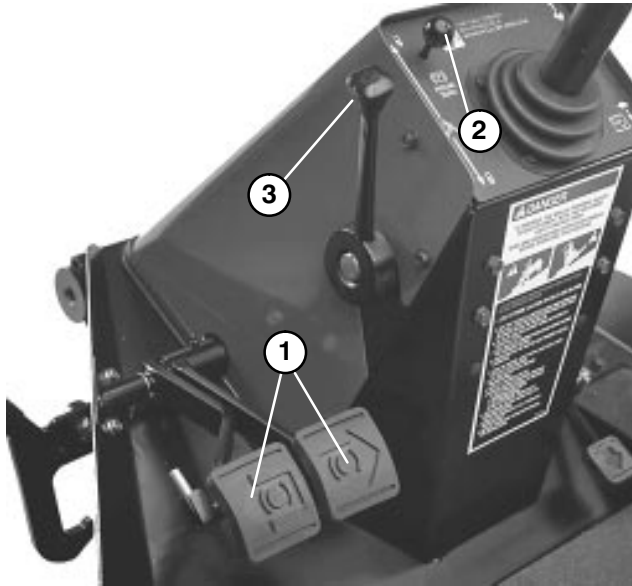

Figure 12

1. Brake Pedals
2. Parking Brake Latch
3. Steering Wheel Tilt Lever

Brake Pedals (Fig. 12) – Two foot pedals at the lower left operate individual wheel brakes for turning assistance, braking, parking and to aid in obtaining better sidehill traction. Locking pin is for parking.

Parking Brake Latch (Fig. 12) – A knob on the left side of console actuates parking brake lock. To engage parking brake, connect pedals with locking pin, push down on both pedals and pull parking brake latch out. To release parking brake, depress both pedals until parking brake latch retracts.

Steering Wheel Tilt Lever (Fig. 12) – Lever on left side of console allows steering wheel to be adjusted for operator comfort.

Transport Latches (Fig. 13) – Four latches secure cutting unit and wings in upright position for transport operation.

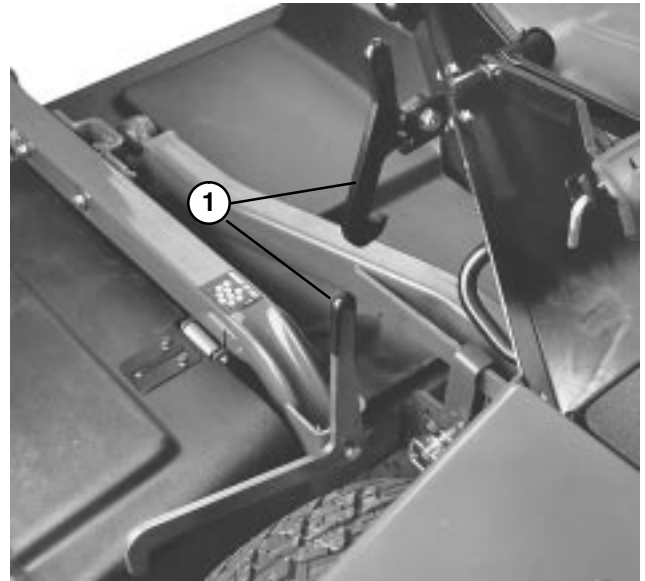

Figure 13

1. Transport Latch (4)

Hour Meter (Under Hood) – Shows total hours that machine has been operated.

Horn – In center of steering wheel. Operates only when key switch is in ON.

OPERATING INSTRUCTIONS

STARTING AND STOPPING

1. Sit on the seat, keep foot off traction pedal. Assure parking brake is engaged, traction pedal is in NEUTRAL and cutting unit engagement switch is in the DISENGAGED position.
2. Turn ignition switch to ON position. When glow plug indicator light goes off, engine is ready to START.
3. Turn ignition key to START. Release key when engine starts.
4. To stop, disengage and move all controls to NEUTRAL and set parking brake. Turn key to OFF and remove it from switch. Raise and latch all cutting units in transport position.

PRIMING FUEL SYSTEM (Fig. 14 & 15)

IMPORTANT: The fuel system may need to be primed when a new engine is started for the first time, if it runs out of fuel or if maintenance is performed on the fuel system.

1. Unlatch and raise hood.
2. Insert a 3/16" hose over bleed screw and run other end into a container to catch fuel.
3. Loosen fuel filter / water separator bleed screw (Fig. 14) a few turns. Pump priming plunger until a steady stream of fuel comes out of hole in bleed screw. When fuel stops foaming, tighten the bleed screw during the downstroke of the priming plunger. Wipe up any spilled fuel.

OPERATING INSTRUCTIONS

Note: Priming fuel filter without opening bleed screw may damage priming plunger.

4. Pump priming plunger until resistance is felt. Try to start engine. If engine does not start repeat step 3.

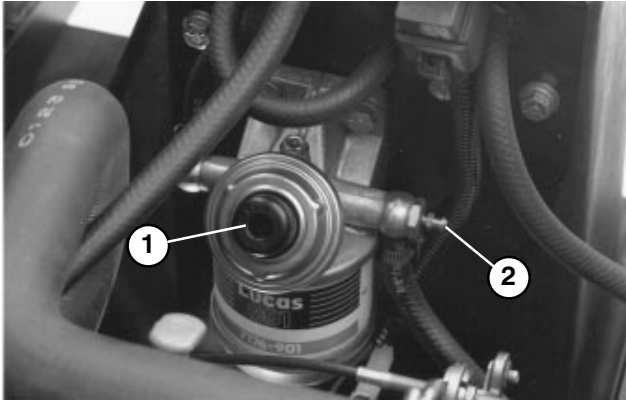

Figure 14
1. Primer Plunger 2. Bleed Screw

Note: It may be necessary to bleed the air out of the fuel line between the fuel filter / water separator and the injection pump. To do this, loosen the fitting on the injection pump (Fig. 15) and repeat bleeding procedure.

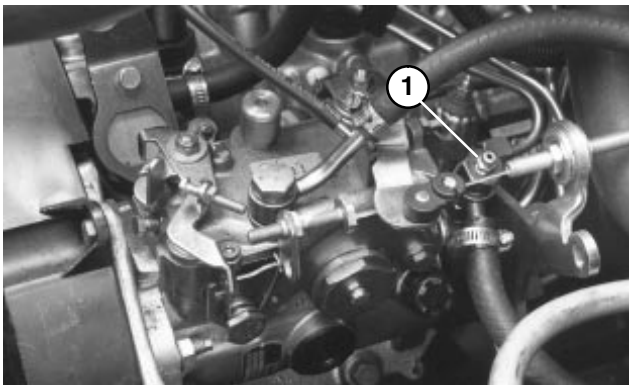

Figure 15
1. Injection Pump Fitting

CHECKING INTERLOCK SYSTEM.

The purpose of the interlock system is to prevent the engine from cranking or starting unless the traction pedal is in NEUTRAL and the cutting unit engagement switch is DISENGAGED. In addition, the engine will stop when the cutting unit engagement switch is engaged or traction pedal is depressed with operator off the seat.

1. In a wide open area free of debris and bystanders, lower cutting unit to the ground. Stop engine.

2. Move cutting unit engagement switch to DISENGAGED position and remove foot from traction pedal so it is fully released.

3. Rotate the ignition key to START. Engine should start. If engine starts, proceed to step 4. If engine does not start, there may be a malfunction in the interlock system.

4. Raise off the seat and engage the cutting unit engagement switch while the engine is running. The engine should stop within 2 seconds. If engine stops, the switch is operating correctly; thus, proceed to step 5. If engine does not stop, there is a malfunction in the interlock system.

6. Raise off the seat and depress the traction pedal while engine is running and the cutting unit engagement switch is DISENGAGED. The engine should stop within 2 seconds. If engine stops, the switch is operating correctly; thus, continue operation. If engine does not stop, there is a malfunction in the interlock system.



CAUTION

THE INTERLOCK SWITCHES ARE FOR THE OPERATOR'S PROTECTION, SO DO NOT DISCONNECT THEM. CHECK OPERATION OF THE SWITCHES DAILY TO ASSURE INTERLOCK SYSTEM IS OPERATING. IF A SWITCH IS DEFECTIVE, REPLACE IT BEFORE OPERATING. REGARDLESS IF SWITCHES ARE OPERATING PROPERLY OR NOT, REPLACE THEM EVERY TWO YEARS TO ASSURE MAXIMUM SAFETY. DO NOT RELY ENTIRELY ON SAFETY SWITCHES – USE COMMON SENSE!

OPERATING CHARACTERISTICS

Familiarization – Before mowing grass, practice operating machine in an open area. Start and stop the engine. Operate in forward and reverse. When you feel familiar with the machine, practice operating around trees and obstacles. Also drive up and down slopes at different speeds.

WARNING: When operating 4 wheel drive machine, always use the seat belt and ROPS together and have seat pivot retaining pin installed.

Another characteristic to consider is the operation of the brake pedals. The brakes can be used to assist in turning the machine. However, use them carefully, especially on soft or wet grass because the turf may be torn accidentally. Another benefit of the brakes is to maintain traction. For example: When operating on a sidehill, the uphill wheel slips and loses traction. If this situation occurs, depress uphill brake pedal gradually and intermittently until the uphill wheel stops slipping, thus, increasing traction on the downhill wheel.

OPERATING INSTRUCTIONS

Warning System – If a warning light comes on during operation, stop the machine immediately and correct the problem before continuing operation. Serious damage could occur if the machine is operated with a malfunction.

Mowing – When you are at the area to be mowed, release cutting unit transport latches.

Move axle shift lever rearward to Mow position and throttle to FAST so engine is running at maximum speed. Lift engagement switch and move forward to engage cutting units.

Curbside Mowing – To reduce the possibility of foreign debris escaping from under the cutter deck while mowing at or near a road or walkway curb, always keep the outside edge of the cutter deck inside the curb. The cutter deck caster wheels should not be guided along the top of the curb; this could cause the cutter deck to hang over the edge of the curb. Never allow the edge of the cutter deck to extend over the edge of the curb while the blades are turning. Always stop mowing and disengage the mower blades when encountering pedestrians or other bystanders/passers-by.

Note: Cutting deck is equipped with a breakaway system to prevent wing decks from being damaged if a solid object is struck. If a wing deck strikes a solid object and unlatches from center cutting deck, raise and lower wing deck to reset in operating position.

WARNING: Cutting deck breakaway system is equipped with a highly compressed spring. If spring removal or repair is required, contact your local authorized Toro Distributor for assistance.

Transport – When mowing is complete, disengage cutting unit and raise it by pulling back on cutting unit lift control levers. Hold levers back until cutting unit is fully raised. **Never raise cutting deck when engaged.** Lock cutting unit in place with transport latches. Move axle shift lever forward to HI position. When driving from one area to another, always shift axle to LO position before encountering a slope. Never shift from HI to LO position while on a slope. Stop machine on a flat surface, engage brakes and shift before climbing the slope. Be careful when driving between objects so you do not accidentally damage the machine or cutting unit.

Use extra care when operating machine on slopes. Drive slowly and avoid sharp turns on slopes to prevent roll overs. The cutting unit must be lowered when going downhill for steering control.

CAUTION: This product may exceed noise levels of 85 dB(A) at the operator position. Ear protectors are recommended, for prolonged exposure, to reduce the potential of permanent hearing damage.

Pushing Or Towing Traction Unit – Use only a rigid tow bar if it becomes necessary to tow machine. Make sure axle shift lever is in NEUTRAL position and only tow the machine forward. Use trailer for normal transport. Move axle shift lever to LO position before loading machine on a trailer.

OPERATING TIPS

Mow When Grass Is Dry—Mow either in the late morning to avoid the dew, which causes grass clumping or in late afternoon to avoid the damage that can be caused by direct sunlight on the sensitive, freshly mowed grass.

Select The Proper Height-of-cut Setting To Suit Conditions – Remove approximately one inch or no more than 1/3 of the grass blade when cutting. In exceptionally lush and dense grass you may have to raise your height-of-cut setting another notch.

Mowing In Extreme Conditions – Air is required to cut and recut grass clippings in mower housing, so do not set height-of-cut too low or totally surround housing by uncut grass. Always try to have one side of the mower housing free from uncut grass, allowing air to be drawn into housing. When making an initial cut thru center of uncut area, operate machine slower and back up if mower starts to clog.

Clippings Discharge – Although the deck has rear discharge, some clippings are discharged toward the left side. To avoid discharging undesirable clippings onto pathways, roads, or other non-turf surfaces, mow with the right side of the deck next to the pathway, road, or other non-turf surface

Mow At Proper Intervals – Under most normal conditions you'll need to mow approximately every 4–5 days. But remember, grass grows at different rates at different times. This means that in order to maintain the same height-of-cut, which is a good practice, you'll need to cut more frequently in early spring; as the grass growth rate slows in mid summer, cut only every 8–10 days. If you are unable to mow for an extended period due to weather conditions or other reasons, mow first with the height-of-cut at a high level; then mow again 2–3 days later with a lower height setting.

Always Mow With Sharp Blades – A sharp blade cuts cleanly and without tearing or shredding the grass blades like a dull blade. Tearing and shredding causes the grass to turn brown at the edges which impairs growth and increases susceptibility to diseases.

After Operating – To assure optimum performance, clean underside of mower housings and under belt covers after each use. Use low psi compressed air only. Do Not Use Water. If residue is allowed to build up in mower housings, cutting performance will decrease.

SERVICE INTERVAL CHARTS

GM 455-D 4WD QUICK REFERENCE AID

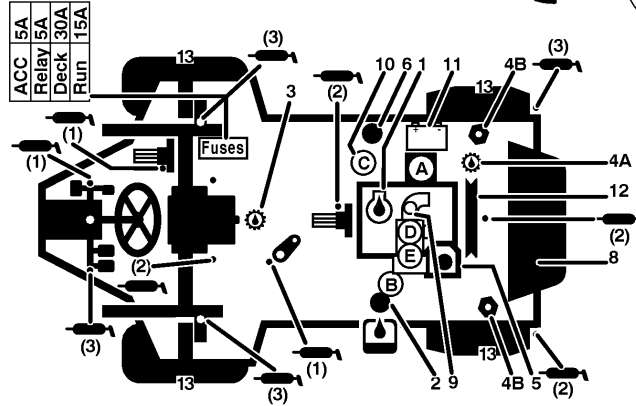

CHECK/SERVICE

- | | |
|------------------------------|---|
| 1. ENGINE OIL LEVEL/FILL | 7. GREASE POINTS (23) |
| 2. HYDRAULIC OIL LEVEL/FILL | 8. RADIATOR SCREEN |
| 3. FRONT AXLE OIL LEVEL/FILL | 9. AIR FILTER SERVICE INDICATOR |
| 4. REAR AXLE OIL | 10. WATER SEPARATOR/FUEL FILTER |
| A. FILL | 11. BATTERY |
| B. CHECK (2) | 12. FAN BELT |
| 5. COOLANT LEVEL/FILL | 13. TIRE PRESSURE (1-1.5 BAR/15-20 PSI) |
| 6. FUEL-DIESEL ONLY | |

FLUID SPECIFICATIONS/CHANGE INTERVALS

See operator's manual for initial changes.	FLUID TYPE		CAPACITY		CHANGE INTERVAL		FILTER
	L	USA	L	USA	FLUID	FILTER	PART NO.
ENGINE OIL	SAE 15W-40 CD	5	5.3 QT	100 HRS	100 HRS	74-7970 (A)	
HYD. CIRCUIT OIL	Mobil DTE 26	24.6	6.5 G	800 HRS	800 HRS	86-3010 (B)	
AXLE OIL	SAE 80-90 E.P.			800 HRS			
FUEL FILTER					400 HRS	76-5220 (C)	
PRIMARY AIR FILTER						SEE SERVICE INDICATOR	93-9162 (D)
SAFETY AIR FILTER						SEE OPERATOR'S MANUAL	93-9163 (E)
FUEL	>32°F 0° C	NO. 2-D	53	14 GAL.	Drain and flush, 800 hours		
	<32°F 0° C	NO. 1-D					
COOLANT	93-7213 50/50 PEUGEOT ANTI-FREEZE	13.25	3.5 GAL.	Drain and flush, 1500 hours or 2 years, whichever occurs first.			93-7242

LUBRICATION

GREASING (Fig. 16–24)

The traction unit and cutting unit have grease fittings that must be lubricated regularly with No. 2 General Purpose Lithium Base Grease. If machine is operated under normal conditions, lubricate all grease fittings after every 25 hours of operation. Lubricate all grease fittings immediately after every washing, regardless of interval listed.

1. The grease fittings that must be lubricated are: Lift arm pivot (2), lift cylinder (4), brake arm pivots (2) (Fig. 16); brake pivot (1), brake pivots (2) (Fig. 17); traction pedal pivot (1) (Fig. 18); engine to pump drive shaft (2) (Fig. 19 & 20); traction adjuster (1) (Fig. 21); P.T.O. Bearing (Fig. 22); tie rod assembly (2), center pivot (1), axle knuckles (2) (Fig. 23); cylinder ends (2) (Fig. 24).

1. Wipe grease fittings clean before lubricating.
2. Pump grease into fitting.
3. Wipe up excess grease.

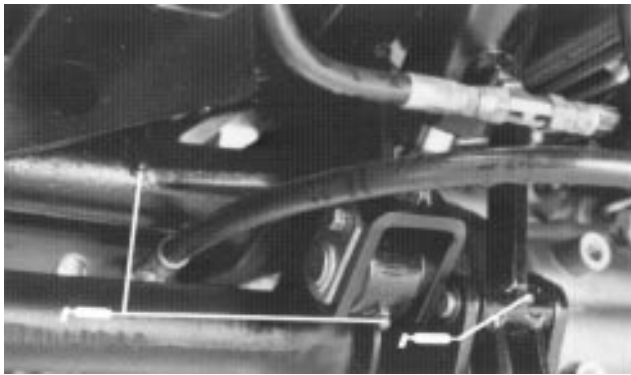

Figure 16

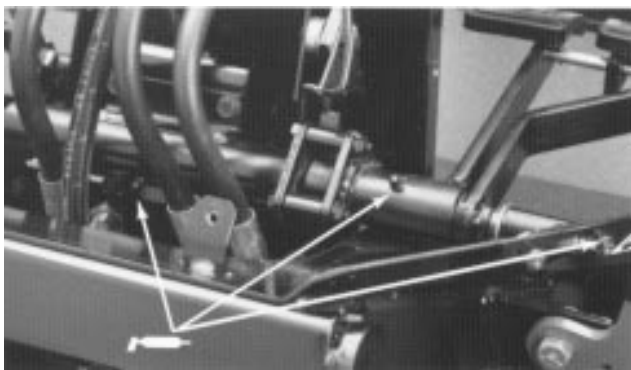

Figure 17



Figure 18

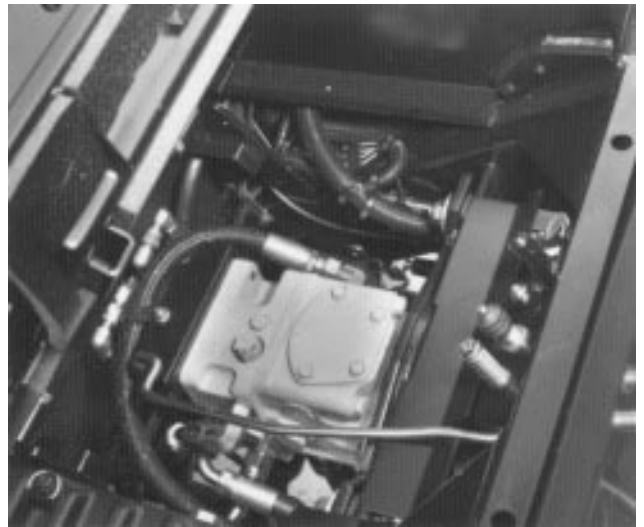

Figure 19

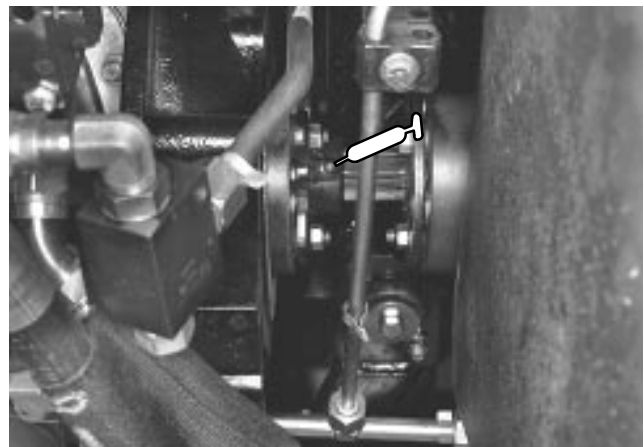

Figure 20

LUBRICATION

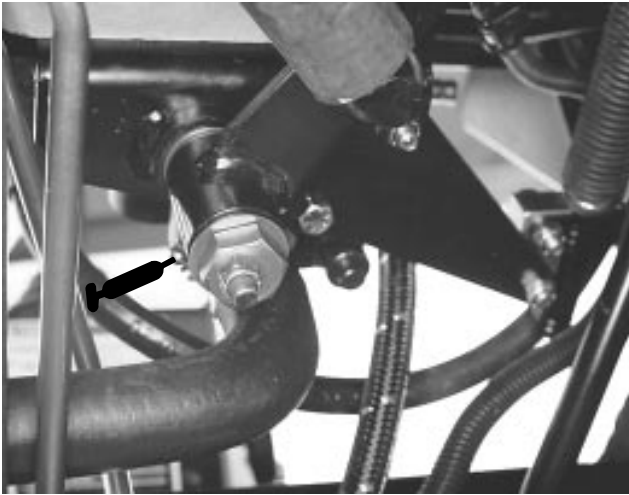

Figure 21

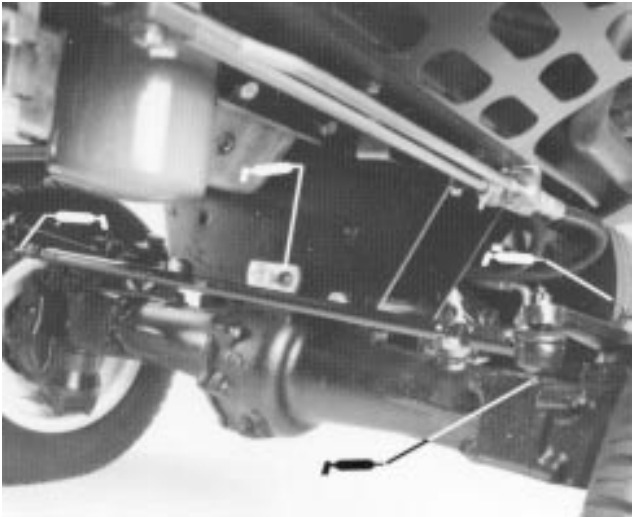

Figure 23

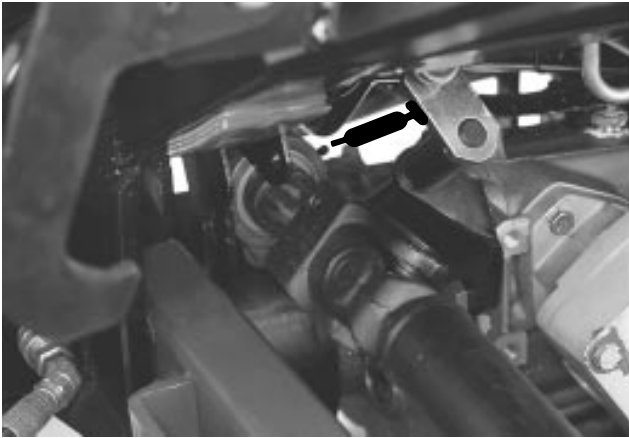

Figure 22



Figure 24

DAILY MAINTENANCE CHECKLIST

Daily Maintenance: (duplicate this page for routine use)

Check proper section of Operator's Manual for fluid specifications

Maintenance Check Item ↴	Daily Maintenance Check For Week Of _____						
	MON	TUES	WED	THURS	FRI	SAT	SUN
✓ Safety Interlock Operation							
✓ Brake Operation							
✓ Engine Oil Level							
✓ Fuel Level							
✓ Cooling System Fluid Level							
Drain Water/Fuel Separator							
✓ Air Filter Restriction Indicator							
✓ Radiator & Screen for Debris ¹							
✓ Unusual Engine Noises ²							
✓ Unusual Operating Noises							
✓ Hydraulic System Oil Level							
✓ Hydraulic Hoses for Damage							
✓ Fluid Leaks							
✓ Tire Pressure							
✓ Instrument Operation							
✓ Cutting Unit Safety Doors							
✓ Height-of-Cut Adjustment							
✓ Clean Deck Belt area ¹							
✓ Condition of Blades							
Lubricate All Grease Fittings ³							
Touch-up Damaged Paint							

¹= Use only low pressure compressed air for debris removal. **Do not use water.**

²= Check glow plug and injector nozzles, if hard starting, excess smoke or rough running is noted.

³= Immediately after every washing, regardless of the interval listed.

Notation for areas of concern: Inspection performed by _____

Item	Date	Information
1		
2		
3		
4		
5		
6		
7		
8		

MAINTENANCE SCHEDULE

Minimum Recommended Maintenance Intervals

Maintenance Procedure	Maintenance Interval & Service				
Inspect Air Filter, Dust Cup and Baffle Lubricate All Grease Fittings Check Cutting Unit Gear Box Oil Level	Every 50hrs	Every 100hrs	Every 200hrs	Every 400hrs	Every 800hrs
† Change Engine Oil and Filter Check Battery Level/Cable Connections Inspect Cooling System Hoses					
† Inspect PTO and Cutting Unit Belts † Check Electric Deck Clutches Adjustment † Check Electric PTO Clutch Adjustment † Torque Wheel Lug Nuts					
● Service Air Cleaner Change Fuel Filter Check Front Transaxle Oil Level Check Rear Axle Oil Level Inspect Fuel Lines and Connections † Check Engine RPM (idle and full throttle)					
† Inspect Engine Fan Belt Inspect Engine Timing Belt (see note below) Drain and Clean Fuel Tank Change Hydraulic Oil † Change Hydraulic Oil Filter Change Front Transaxle Oil Change Rear Axle Oil Check Rear Wheel Toe-in					
† Initial break in at 10 hours † Initial break in at 50 hours ● If indicator shows red					
Replace Moving Hydraulic Hoses Replace Safety Switches Cooling System Flush/Replace Fluid Replace PTO Belts/Cutter Deck Belts					
			Annual Recommendations: Items listed are recommended every 1500 hours or 2 years, whichever occurs first.		

NOTE: Replace Timing Belt if worn, cracked or oil soaked. A new Timing Belt should be installed any time the Belt is removed or loosened.

AIR CLEANER MAINTENANCE



CAUTION

Before servicing or making adjustments to the machine, stop engine and remove key from the switch.

GENERAL AIR CLEANER MAINTENANCE

1. Check air cleaner body for damage which could possibly cause an air leak. Replace a damaged air cleaner body.
2. Service the air cleaner filters when ever air cleaner indicator (Fig. 25) shows red or every 400 hours (more frequently in extreme dusty or dirty conditions). Do not over service air filter.

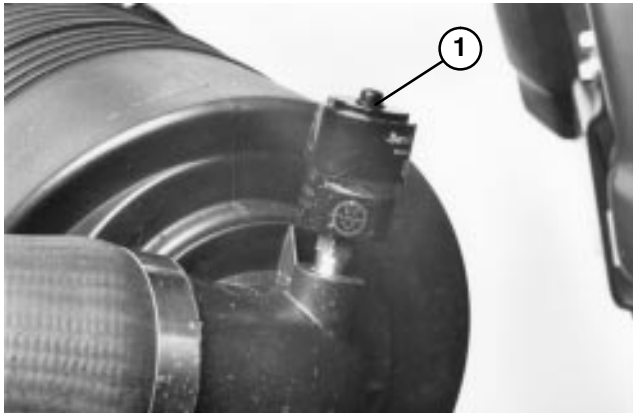

Figure 25
1. Air cleaner indicator

2. Be sure cover is sealing around air cleaner body.

SERVICING AIR CLEANER

1. Release latches securing air cleaner cover to air cleaner body. Separate cover from body. Clean inside of air cleaner cover.

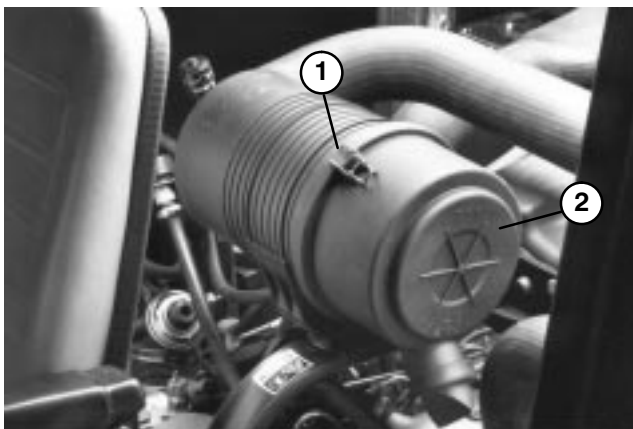

Figure 26
1. Air cleaner latches
2. Dust cup

2. Gently slide primary filter (Fig. 27) out of air cleaner body to reduce the amount of dust dislodged. Avoid knocking filter against air cleaner body. **Do not remove safety filter.**

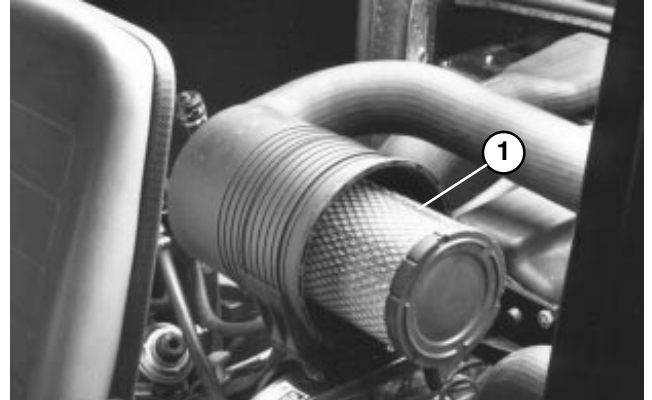

Figure 27
1. Air cleaner primary filter

3. Inspect primary filter and discard if damaged. Do not wash or reuse a damaged filter.

IMPORTANT: Never attempt to clean a safety filter (Located inside primary filter). Replace the safety filter with a new one after every three primary filter services.

Washing Method

- A. Prepare a solution of filter cleaner and water and soak filter element about 15 minutes. Refer to directions on filter cleaner carton for complete information.
- B. After soaking filter for 15 minutes, rinse it with clear water. Maximum water pressure must not exceed 40 psi to prevent damage to the filter element. Rinse filter from clean side to dirty to side.
- C. Dry filter element using warm, flowing air (160°F) max), or allow element to air-dry. Do not use a light bulb to dry the filter element because damage could result.

Compressed Air Method

- A. Blow compressed air from inside to the outside of dry filter element. Do not exceed 100 psi to prevent damage to the element.
 - B. Keep air hose nozzle at least 2" from filter and move nozzle up and down while rotating the filter element. Inspect for holes and tears by looking through the filter toward a bright light.
5. Inspect new filter for shipping damage. Check sealing end of filter. Do not install a damaged filter.
 6. Insert new filter properly into air cleaner body. Make sure filter is sealed properly by applying pressure to outer rim of filter when installing. Do not press on flexible center of filter.
 7. Reinstall cover and secure latches. Make sure cover is positioned with TOP side up.
 8. Reset indicator (Fig. 25) if showing red.

ENGINE MAINTENANCE



CAUTION

Before servicing or making adjustments to the machine, stop engine and remove key from the switch.

ENGINE OIL AND FILTER (Fig. 28–29)

Change oil and filter initially after the first 50 hours of operation, thereafter change oil and filter every 100 hours.

1. Remove drain plug (Fig. 28) and let oil flow into drain pan. When oil stops, install drain plug and new plug seal.



Figure 28
1. Drain Plug

2. Remove oil filter (Fig. 29). Apply a light coat of clean oil to the new filter seal before screwing it on. DO NOT OVER-TIGHTEN.

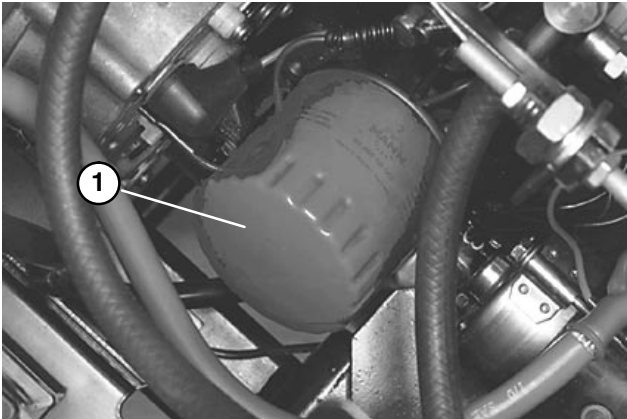

Figure 29
1. Oil Filter

3. Add 15W–40 CD oil to crankcase. Capacity is 5.3 quarts with filter.

FUEL SYSTEM (Fig. 30)

Fuel Tank

Drain and clean fuel tank every 800 hours of operation or yearly, whichever comes first. Also, drain and clean tank if fuel system becomes contaminated or if machine is to be stored for an extended period. Use clean fuel to flush out the tank.



DANGER

Because diesel fuel is highly flammable, use caution when storing or handling it. Do not smoke while filling the fuel tank. Do not fill fuel tank while engine is running, hot, or when machine is in an enclosed area. Always fill fuel tank outside and wipe up any spilled diesel fuel before starting the engine. Store fuel in a clean, safety-approved container and keep cap in place. Use diesel fuel for the engine only; not for any other purpose.

Fuel Lines and Connections

Check lines and connections every 400 hours or yearly, whichever comes first. Inspect for deterioration, damage, or loose connections.

Draining Fuel Filter / Water Separator

Drain water or other contaminants from fuel filter / water separator daily.

1. Place a clean container under fuel filter.

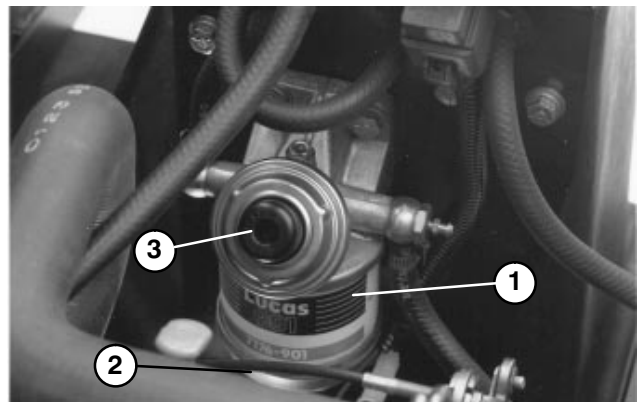

Figure 30
1. Fuel Filter / Water Separator
2. Drain Screw
3. Primer Plunger

2. Loosen drain thumb screw on side of fuel filter and press primer plunger until only fuel is evident draining into container.

3. Tighten drain screw.

ENGINE MAINTENANCE

Changing Fuel Filter

Replace fuel filter if fuel flow becomes restricted, after every 400 hours of operation or annually, whichever comes first.

1. Unscrew bottom filter cap from filter assembly. Remove cap, gaskets, o-ring and filter from assembly. Note position of gaskets and o-ring when disassembling from filter.
2. Install new filter, gaskets, o-ring with filter assembly cap.
3. Prime fuel system, refer to Priming Fuel System.

ENGINE COOLING SYSTEM (Fig. 31–32)

1. Removing Debris – Remove debris from rear screen, oil cooler and radiator daily, clean more frequently in dirty conditions. Use low pressure compressed air.

IMPORTANT: Never spray water onto a hot engine or onto electrical connections as damage may occur.

- A. Turn engine off, release hood latch and raise hood. Clean engine area thoroughly of all debris. Close hood.
- B. Unscrew knobs and remove rear screen (Fig. 31). Clean screen thoroughly.

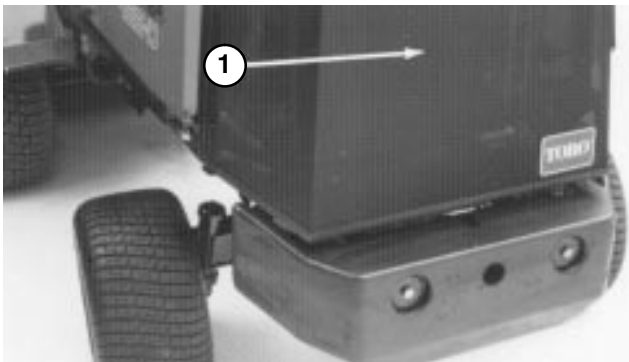

Figure 31
1. Rear Screen

C. Unscrew knobs and pivot oil cooler rearward. Clean both sides of oil cooler and radiator area thoroughly with low pressure compressed air. Open hood and blow debris out toward back of machine. Pivot oil cooler back into position and tighten knobs.

Note: Upper portion of fan shroud may be easily unbolted from machine to simplify cleaning.

D. Install rear screen and tighten knobs.

IMPORTANT: Do not use water to clean engine, as damage may occur.



Figure 32
1. Oil Cooler

2. Maintaining Cooling System – Capacity of the system is 3.5 gal. Always protect cooling system with a 50/50 solution of water and Peugeot recommended anti-freeze. **DO NOT USE WATER ONLY IN COOLING SYSTEM.**

- A. After every 100 operating hours, tighten hose connections. Replace any deteriorated hoses.
- B. After every 2 years or 1500 hours, drain and flush the cooling system. Add anti-freeze (refer to Check Cooling System).

ENGINE FAN BELT (Fig. 33)

Check condition and tension of fan belt (Fig. 33) frequently. It is recommended that belt be inspected every 800 hours of operation.

1. Proper tension will allow 1/4 in. deflection on the belt midway between the pulleys, when pressed firmly with thumb.
2. If deflection exceeds 1/4 in., loosen alternator mounting bolts. Adjust alternator belt tension by adjusting tension screw. Check deflection of belt again to assure tension is correct.

ENGINE MAINTENANCE

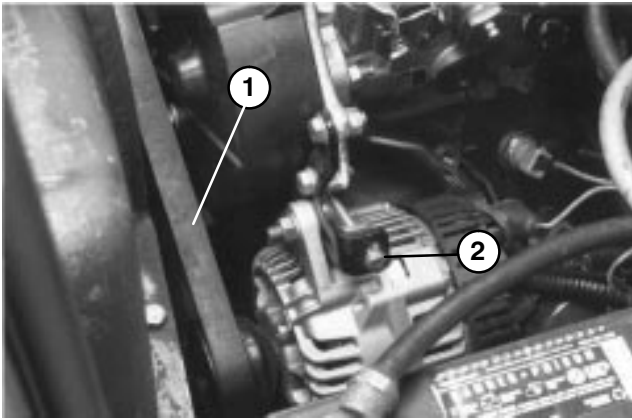

Figure 33
1. Fan Belt 2. Adjusting Screw

ENGINE TIMING BELT (Fig. 33)

Inspect engine timing belt every 800 hours of operation or yearly.

1. Remove covers and check for worn, cracked or oil soaked belt.

Note: A new belt should be installed any time belt is removed or loosened.

HYDRAULIC MAINTENANCE



CAUTION

Before servicing or making adjustments to the machine, stop engine and remove key from the switch.

CHANGING HYDRAULIC OIL (Fig. 34 & 35)

Change hydraulic oil filter initially after the first 50 hours of operation, thereafter change hydraulic oil and filter after every 800 operating hours. If oil becomes contaminated, contact your local TORO distributor because the system must be flushed. Contaminated oil looks milky or black when compared to clean oil.

1. Turn engine off, release hood latch and raise hood.
2. Remove drain plug from rear of reservoir and hydraulic line from front of reservoir (Fig. 34) and let hydraulic oil flow into drain pan. Reinstall and tighten plug and line when hydraulic oil stops draining.
3. Fill reservoir with approximately 6.5 gallons of hydraulic oil. Refer to Check Hydraulic Circuit Oil.

IMPORTANT: Use only hydraulic oils specified. Other fluids could cause system damage.

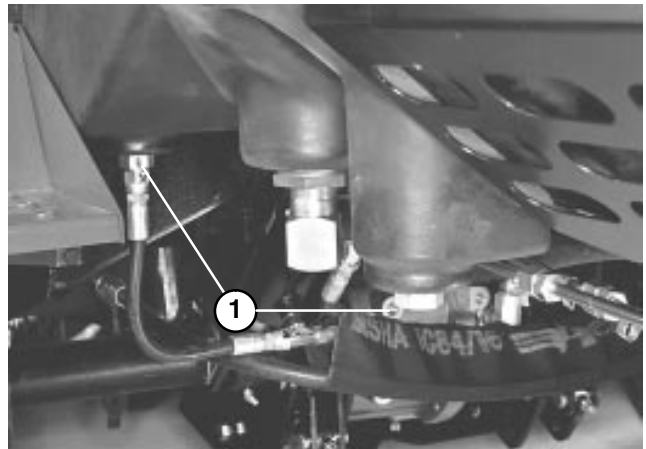

Figure 34
1. Hydraulic Reservoir Drain

4. Install reservoir cap, lower hood and latch. Start engine and use all hydraulic controls to distribute hydraulic oil throughout the system. Also check for leaks. Then stop the engine.

HYDRAULIC MAINTENANCE

5. With wing decks raised, center deck down and oil warm, look into sight gauge (Fig. 35). If hydraulic oil is not visible, add enough oil to raise level to middle (maximum) of sight gauge. To prevent over filling, do not fill if oil is cold. **DO NOT OVER FILL.**

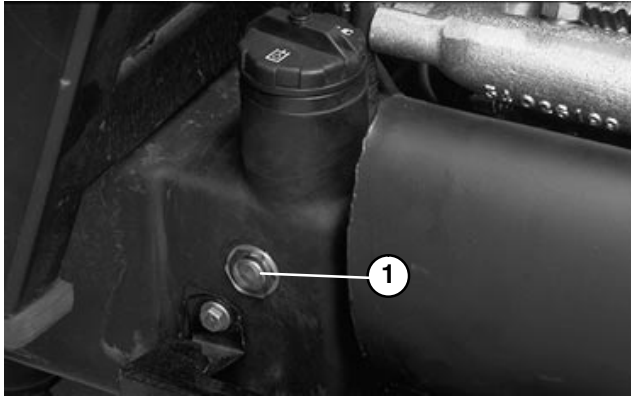

Figure 35
1. Sight Gauge

REPLACING HYDRAULIC FILTER (Fig. 36)

Initially, change filter after the first 50 operating hours, thereafter, every 800 operating hours or annually, whichever comes first.

Only the Toro replacement filter (Part No.86–3010) can be used in the hydraulic system.

IMPORTANT: Use of any other filter may void the warranty on some components.

1. Turn engine off, release hood latch and raise hood.
2. Clean area around filter mounting area (Fig. 36). Place drain pan under filter and remove filter.

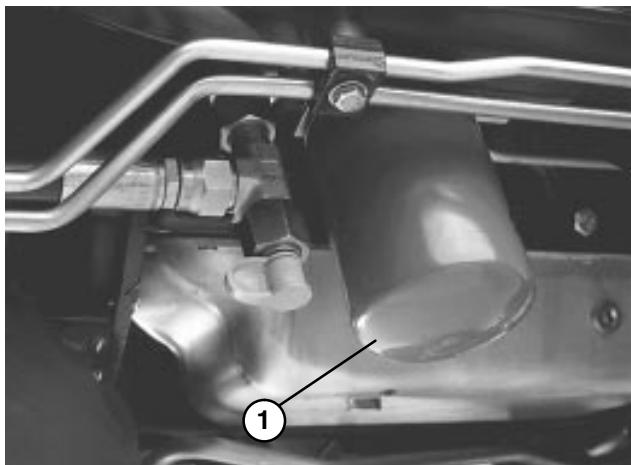

Figure 36
1. Hydraulic Filter

3. Lubricate new filter gasket and fill the filter with hydraulic oil.
4. Assure filter mounting area is clean. Screw filter on until gasket contacts mounting plate. Then tighten filter one-half turn.

5. Start engine and let run for about two minutes to purge air from the system. Stop the engine and check oil level. Also check for any leaks.

CHECKING HYDRAULIC LINES AND HOSES

Check hydraulic lines and hoses daily for leaks, kinked lines, loose mounting supports, wear, loose fittings, weather deterioration and chemical deterioration. Make all necessary repairs before operating.



WARNING

Keep body and hands away from pin hole leaks or nozzles that eject high pressure hydraulic fluid. Use cardboard or paper to find hydraulic leaks. Hydraulic fluid escaping under pressure can penetrate skin and cause injury. Fluid accidentally injected into the skin must be surgically removed within a few hours by a doctor familiar with this form of injury or gangrene may result.

HYDRAULIC SYSTEM TEST PORTS

(Fig. 37 & 40)

The test ports are used to test the hydraulic circuits. Check all pressures when engine is at full speed and hydraulic oil is at normal operating temperature. Contact your local Toro distributor for assistance.

1. Traction Forward and Reverse have a normal relief setting of approximately 6000 psi.
2. Normal charge pressure is 100–140 psi.

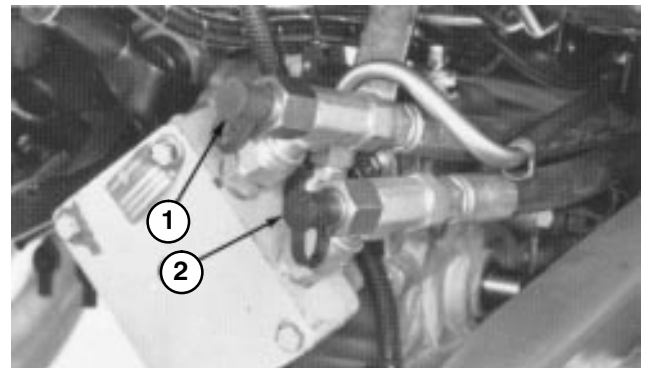

Figure 37
1. Traction Forward Circuit
2. Traction Reverse Circuit

3. Cutting unit Counterbalance normal setting is approximately 600–650 psi @ high Idle and when oil is warm.
4. Lift circuit relief pressure is approximately 2600–2800 psi when oil is warm.

HYDRAULIC MAINTENANCE

5. Steering Circuit has a normal relief setting of approximately 1200 psi @ high idle and warm oil.

6. Wing deck cutting unit Counterbalance normal setting is approximately 350–400 psi @ high Idle and when oil is warm.



Figure 38
1. Charge Pressure

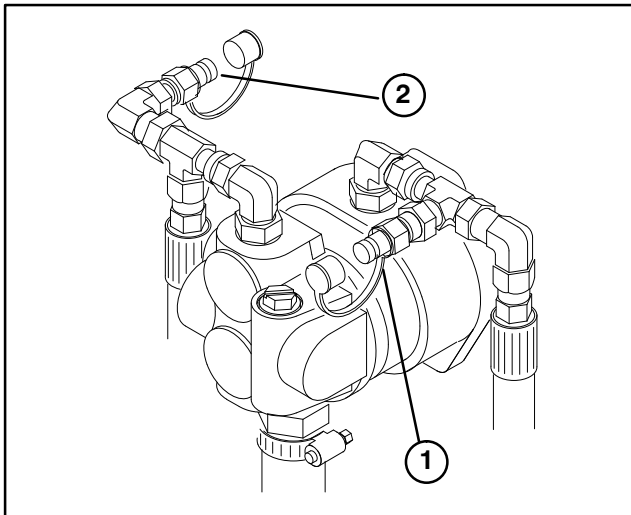

Figure 39
1. Counterbalance/Lift Circuit
2. Steering Circuit

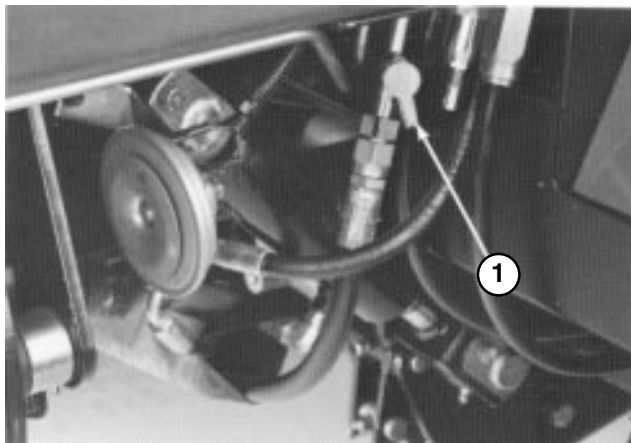

Figure 40
1. Counterbalance (Wing Decks)

ADJUSTING TRACTION DRIVE FOR NEUTRAL (Fig. 41)

The machine must not creep when traction pedal is released. If it does creep, an adjustment is required.

1. Park machine on a level surface, shut engine off and move shift lever to “HI” position. Depress only the left brake pedal and engage the parking brake.
2. Jack up right side of machine until front tire is off the shop floor. Support machine with jack stands to prevent it from falling accidentally.
3. Under left side of machine, loosen locknut on traction adjustment cam.

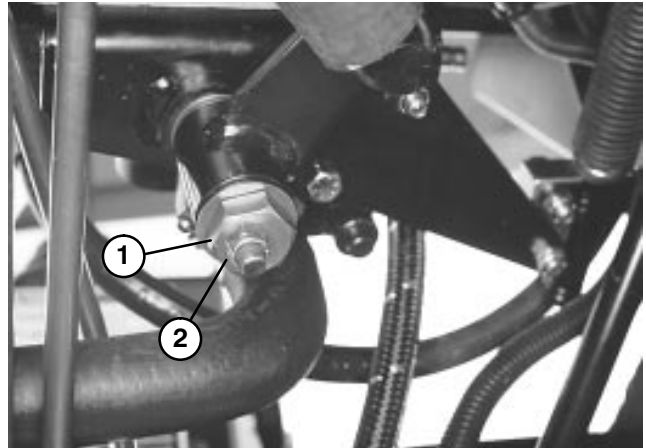

Figure 41
1. Traction Adjustment Cam
2. Locknut

4. Start engine and rotate cam hex in either direction until wheel ceases rotation.



WARNING

Engine must be running so final adjustment of the traction adjustment cam can be performed. To guard against possible personal injury, keep hands, feet, face and other parts of the body away from the muffler, other hot parts of the engine, and other rotating parts.

5. Tighten locknut locking adjustment.
6. Stop the engine and release the right brake. Remove jack stands and lower the machine to the shop floor. Test drive the machine to make sure it does not creep.

HYDRAULIC SCHEMATIC

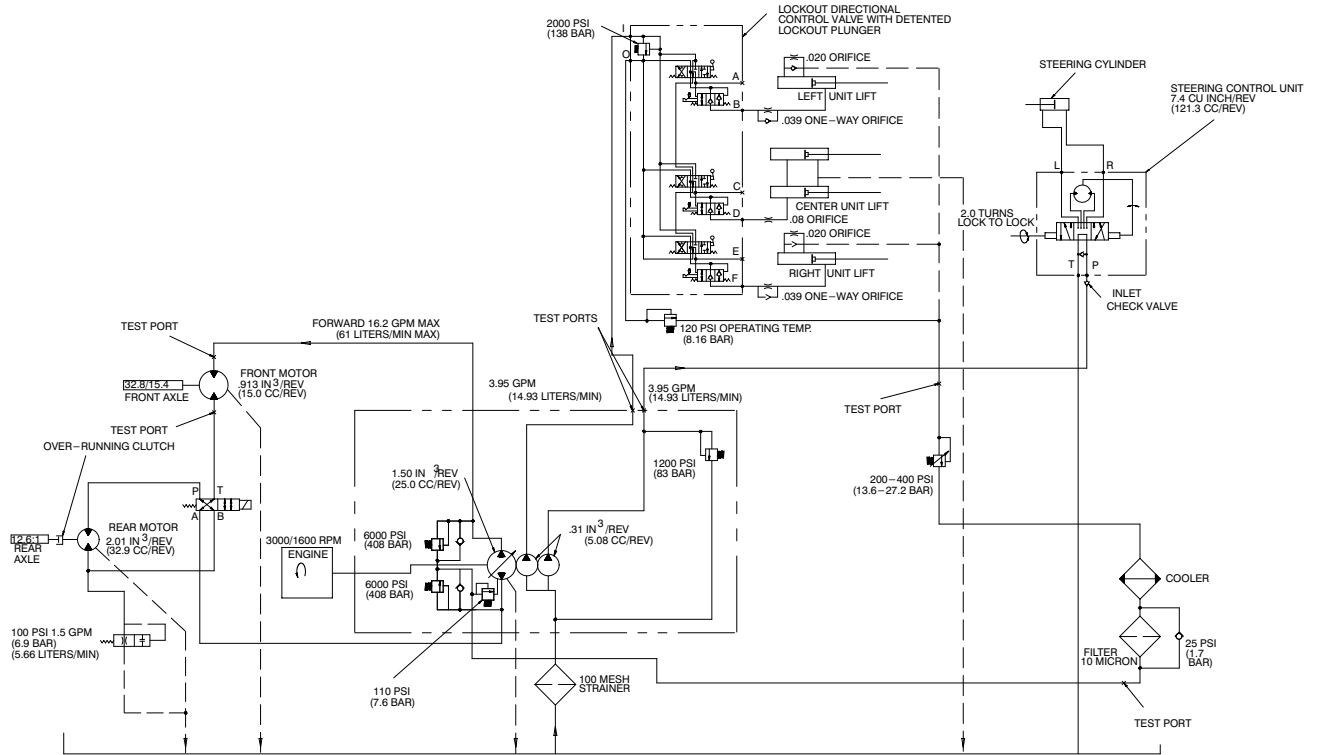

AXLE MAINTENANCE



CAUTION

Before servicing or making adjustments to the machine, stop engine and remove key from the switch.

CHANGING FRONT AXLE LUBRICANT

(Fig. 42)

After every 800 hours of operation the oil in the front axle must be changed.

1. Position machine on a level surface.
2. Clean area around the drain plug (Fig. 42).

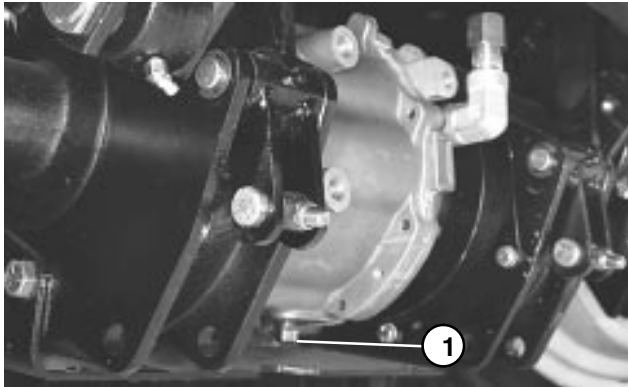

Figure 42

1. Front Axle Drain Plug

3. Remove plug allowing oil to drain into drain pans.
4. After oil is drained, reinstall drain plug into axle.
5. Fill axle with lubricant; refer to Check Front Axle Oil Level, page 12.

CHANGING REAR AXLE LUBRICANT

(Fig. 43)

After every 800 hours of operation the oil in the rear axle must be changed.

1. Position machine on a level surface.
2. Clean area around the (3) drain plugs, (1) on each end and (1) in the center (Fig. 43).

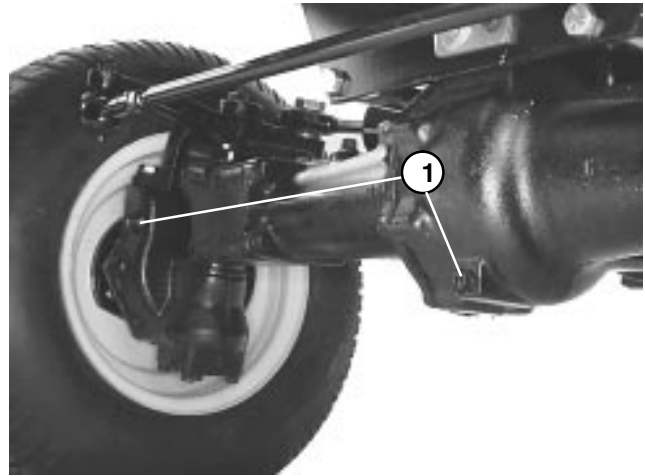

Figure 43

1. Drain Plugs (3)

3. Remove plugs allowing oil to drain into drain pans.
4. After oil is drained, apply thread sealing compound on drain plug threads and reinstall in axle.
5. Fill axle with lubricant; refer to Check Rear Axle Lubricant, page 12.

REAR WHEEL TOE-IN (Fig. 44)

After every 800 operating hours or annually, check rear wheel toe-in.

1. Measure center-to-center distance (at axle height) at front and rear of steering tires. Front measurement must be 1/4 in. less than rear measurement.

2. To adjust, loosen clamps at both ends of tie rods.



Figure 44

1. Tie Rod Clamps

3. Rotate tie rod to move front of tire inward or outward.
4. Tighten tie rod clamps when adjustment is correct.

BRAKE MAINTENANCE

ADJUSTING SERVICE BRAKES (Fig. 45)

Adjust the service brakes when there is more than 1–1/2" of "free travel" of the brake pedal, or when the brakes do not work effectively. Free travel is the distance the brake pedal moves before braking resistance is felt.

1. To reduce free travel of brake pedals, tighten nut on brake rod adjuster, 1/2 turn at a time, until desired "free play" in pedal is achieved.

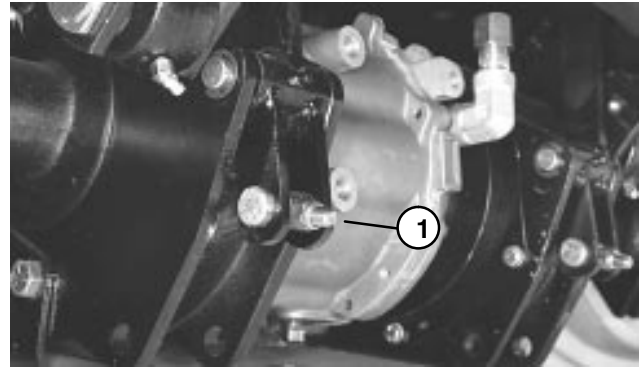

Figure 45
1. Brake Rod Adjuster

P.T.O. MAINTENANCE



CAUTION

Before servicing or making adjustments to the machine, stop engine and remove key from the switch.

ADJUSTING P.T.O. BELT (Fig. 46–47)

Re-tension P.T.O. belt (Fig. 47) initially after the first 10 hours of operation, thereafter, check condition and tension of belt every 100 hours. It is recommended that belt be replaced after every 1500 hours of operation.

1. Remove (2) screws securing P.T.O. belt cover to adapter plate and (1) screw securing belt cover to tab on spring anchor. Remove cover.

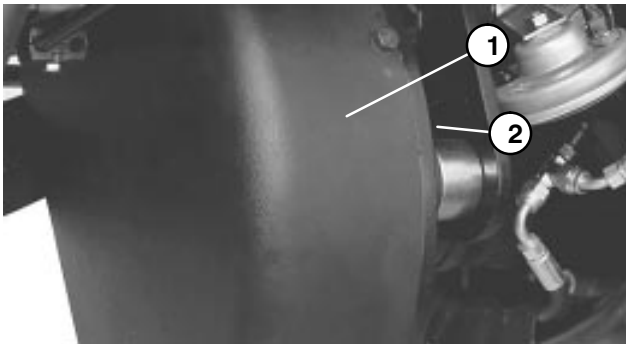

Figure 46
1. P.T.O. Belt Cover
2. Adapter Plate

2. Loosen (3) flange screws and flange nuts securing adapter plate to clutch plate.
3. Insert end of 1/2 drive, 20" long, torque wrench into square hole in clutch plate. With wrench handle parallel to ground, pull wrench upward until 180 ft–lbs. of torque is applied to tension belt.
4. Tighten flange screws and flange nuts locking adjustment.
5. Reinstall P.T.O. belt cover with screws previously removed.

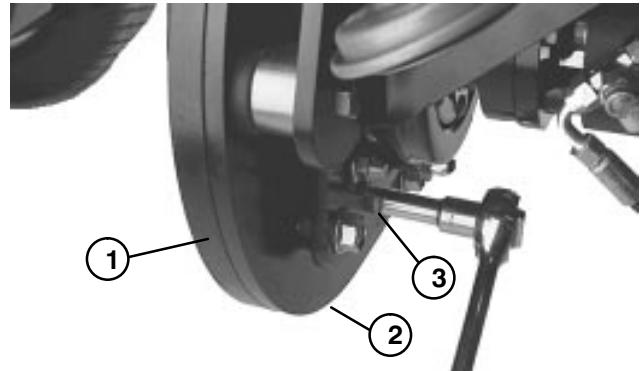

Figure 47
1. P.T.O. Belt 2. Adapter Plate 3. Square hole

ADJUSTING CLUTCH (Fig. 48)

The P.T.O. clutch is adjustable to ensure proper engagement and blade braking. Check clutch adjustment initially after the first 10 hours of operation, thereafter, check every 200 hours.

1. To adjust clutch, tighten or loosen locknuts on flange studs.
2. Check adjustment by inserting feeler gauge thru slots next to flange studs.
3. The proper disengaged clearance between the clutch plates is .011 – .021 inches. It will be necessary to check this clearance at each of the three slots to ensure the plates are parallel to each other.

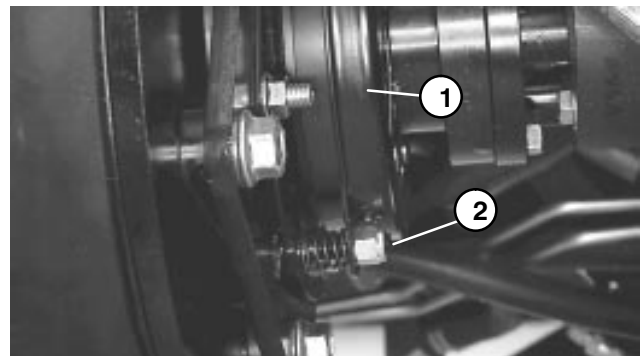

Figure 48
1. Clutch
2. Flange studs

ELECTRICAL MAINTENANCE



CAUTION

Before servicing or making adjustments to the machine, stop engine and remove key from the switch.

BATTERY CARE

IMPORTANT: Before welding on the machine, disconnect ground cable from the battery to prevent damage to the electrical system.

Note: Check battery condition weekly or after every 100 hours of operation. Keep terminals and entire battery case clean because a dirty battery will discharge slowly. To clean the battery, wash the entire case with solution of baking soda and water. Rinse with clear water. Coat the battery posts and cable connectors with Grafo 112X (skin-over) grease (Toro Part No. 505-47) or petroleum jelly to prevent corrosion.

FUSES (Fig. 49)

There are 4 fuses in the machines electrical system. They are located inside control panel.

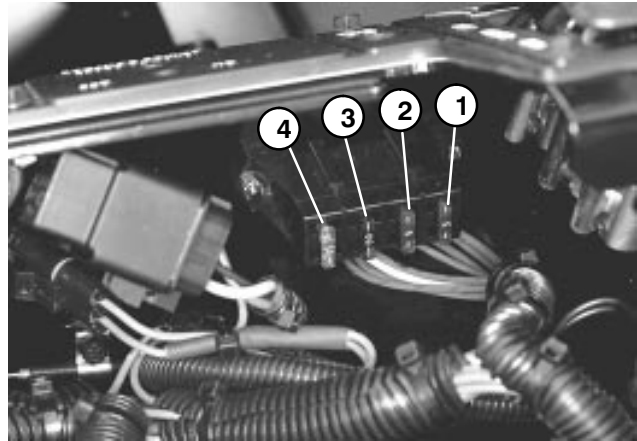
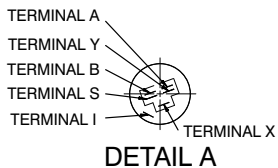
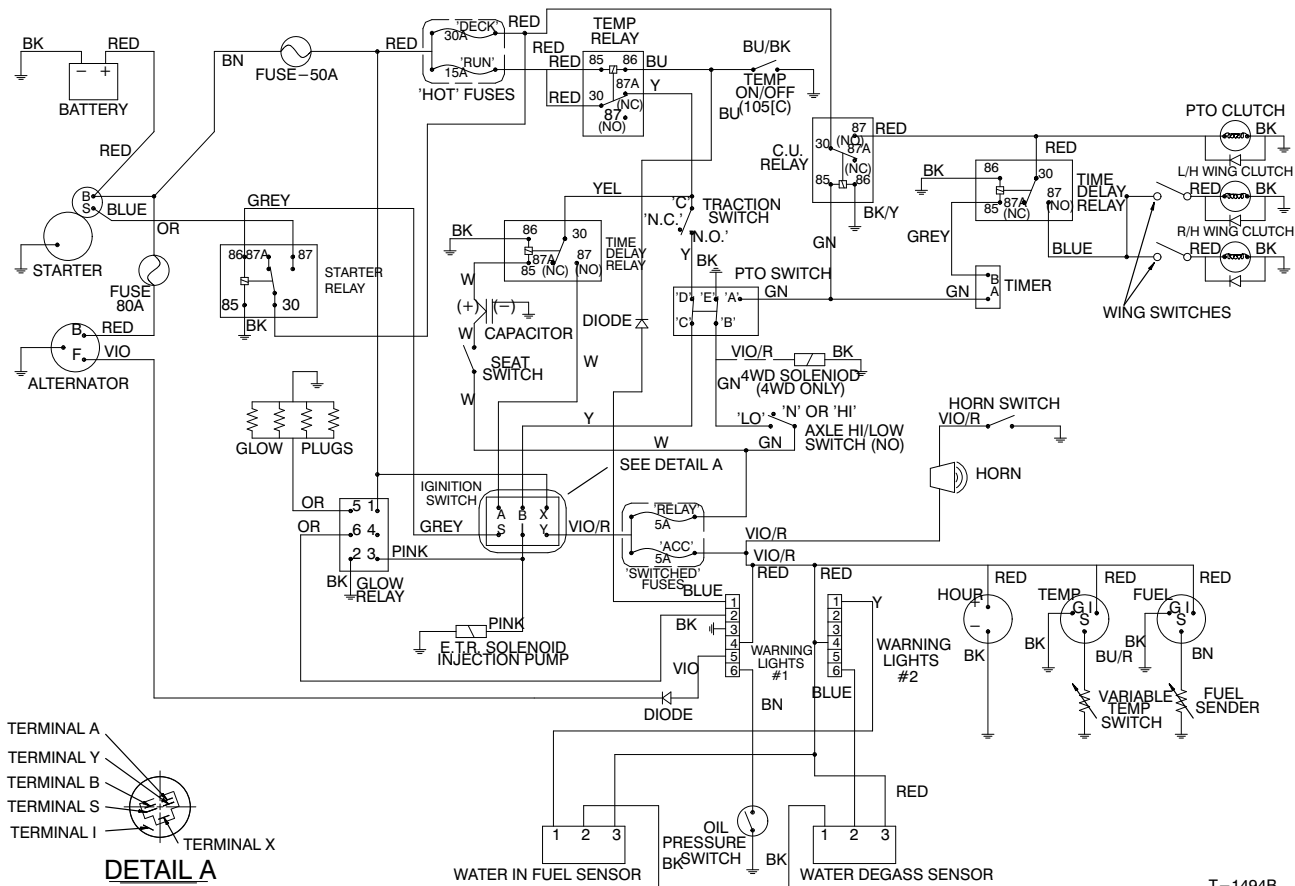

Figure 49

- 1. ACC Fuse
- 2. Relay Fuse
- 3. Deck Fuse
- 4. Run FUSE

FUSES	
ACC	5A
RELAY	5A
DECK	30A
RUN	15A

ELECTRICAL SCHEMATIC



PREPARATION FOR SEASONAL STORAGE

Traction Unit

1. Thoroughly clean the traction unit, cutting units and the engine.
2. Check the tire pressure. Inflate all tires to 20 psi.
3. Check all fasteners for looseness; tighten as necessary.
4. Grease or oil all grease fittings and pivot points. Wipe up any excess lubricant.
5. Lightly sand and use touch-up paint on painted areas that are scratched, chipped, or rusted. Repair any dents in the metal body.
6. Service the battery and cables as follows:
 - a. Remove the battery terminals from the battery posts.
 - b. Clean the battery, terminals, and posts with a wire brush and baking soda solution.
 - c. Coat the cable terminals and battery posts with Grafo 112X skin-over grease (Toro Part No. 505-47) or petroleum jelly to prevent corrosion.
 - d. Slowly recharge the battery every 60 days for 24 hours to prevent lead sulfation of the battery.

Engine

1. Drain the engine oil from the oil pan and replace the drain plug.
2. Remove and discard the oil filter. Install a new oil filter.
3. Refill oil pan with 5.3 quarts of SAE15W-40 CD motor oil.
4. Start the engine and run at idle speed for approximately two minutes.
5. Stop the engine.
6. Flush the fuel tank with fresh, clean diesel fuel.
7. Re-secure all fuel system fittings.
8. Thoroughly clean and service the air cleaner assembly.
9. Seal the air cleaner inlet and the exhaust outlet with weatherproof tape.
10. Check anti freeze protection and add a 50/50 solution of water and Peugeot recommended anti freeze (Toro part No. 93-7213) as needed for expected minimum temperature in your area.

The Toro Commercial Products Two Year Limited Warranty

The Toro Company warrants your 1996 or newer Toro Commercial Product ("Product") purchased after January 1, 1997, to be free from defects in materials or workmanship for the period of time listed below. Where a warrantable condition exists, Toro will repair the Product at no cost to you including diagnosis, labor, parts, and transportation. This warranty begins on the date the Product is delivered to the original retail purchaser.

Warranty Duration: Two years or 1500 operational hours*, whichever occurs first.

***Product equipped with hour meter**

Owner Responsibilities:

As the Product owner, you are responsible for required maintenance and adjustments stated in your Owner's Manual. Failure to perform required maintenance and adjustments can be grounds for disallowing a warranty claim.

Instructions for Obtaining Warranty Service:

You are responsible for notifying the Commercial Products Distributor or Authorized Commercial Products Dealer from whom you purchased the Product as soon as you believe a warrantable condition exists.

If you need help locating a Commercial Products Distributor or Authorized Dealer, or if you have questions regarding your warranty rights or responsibilities, you may contact us at:

Toro Commercial Products Service Department
8111 Lyndale Avenue South
Minneapolis, MN, 55420-1196
Telephone: (612) 888-8801
Facsimile: (612) 887-8258
E-Mail: Commercial.Service@Toro.Com

Maintenance Parts:

Parts scheduled for replacement as required maintenance ("Maintenance Parts"), are warranted for the period of time up to the scheduled replacement time for that part.

Items/Conditions Not Covered:

Not all product failures or malfunctions that occur during the warranty period are defects in materials or workmanship. The items / conditions listed below are not covered by this warranty:

- Product failures which result from the use of non-Toro replacement parts, or from installation and use of add-on, modified, or unapproved accessories are not covered.
- Product failures which result from failure to perform required maintenance and/or adjustments are not covered.
- Product failures which result from operating the Product in an abusive, negligent or reckless manner are not covered.

- This warranty does not apply to parts subject to consumption through use unless found to be defective. Examples of parts which are consumed, or used up, during normal Product operation include, but are not limited to, blades, reels, bedknives, tines, spark plugs, castor wheels, tires, filters, belts, etc.
- This warranty does not apply to failures caused by outside influence. Items considered to be outside influence include, but are not limited to, weather, storage practices, contamination, use of unapproved coolants, lubricants, additives, or chemicals, etc.
- This warranty does not apply to normal "wear and tear" items. Normal "Wear and Tear" includes, but is not limited to, damage to seats due to wear or abrasion, worn painted surfaces, scratched decals or windows, etc.

Other Legal Disclaimers:

The above remedy of product defects through repair by an authorized distributor or dealer is the purchaser's sole remedy for any defect. This warranty gives you specific legal rights, and you may also have other rights which vary from state to state.

Except for the Emissions warranty referenced below, if applicable, there is no other express warranty. All implied warranties of merchantability and fitness for use are limited to the duration of the express warranty.

Some states do not allow limitations on how long an implied warranty lasts, so the above limitation may not apply to you.

The Toro Company is not liable for indirect, incidental or consequential damages in connection with the use of the Product, including any cost or expense of providing substitute Product or service during periods of malfunction or non-use.

Some states do not allow the exclusion of incidental or consequential damages, so the above exclusion may not apply to you.

Note to California residents: The Emissions Control System on your Product may be covered by a separate warranty meeting requirements established by the U.S. Environmental Protection Agency (EPA), or the California Air Resources Board (CARB). The hour limitations set forth above do not apply to the Emissions Control System Warranty. Refer to the California Emission Control Warranty Statement printed in your Owner's Manual or contained in the engine manufacturer's documentation for details.