



Count on it.

Operator's Manual

GrandStand® Mower

**With 48in, 52in or 60in TURBO FORCE®
Cutting Unit**

Model No. 74549—Serial No. 313000001 and Up

Model No. 74553—Serial No. 313000001 and Up

Model No. 74578—Serial No. 313000001 and Up

Model No. 79548—Serial No. 313000001 and Up

Model No. 79549—Serial No. 313000001 and Up

Model No. 79553—Serial No. 313000001 and Up



WARNING

CALIFORNIA Proposition 65 Warning

The engine exhaust from this product contains chemicals known to the State of California to cause cancer, birth defects, or other reproductive harm.

This spark ignition system complies with Canadian ICES-002.

Important: This engine is not equipped with a spark arrester muffler. It is a violation of California Public Resource Code Section 4442 to use or operate the engine on any forest-covered, brush-covered, or grass-covered land. Other states or federal areas may have similar laws.

⚠ WARNING

Removing standard original equipment parts and accessories may alter the warranty, traction, and safety of the machine. Failure to use original Toro parts could cause serious injury or death. Making unauthorized changes to the engine, fuel or venting system, may violate EPA and CARB regulations.

Replace all parts including, but not limited to, tires, belts, blades, and fuel system components with original Toro parts.

The enclosed *Engine Owner's Manual* is supplied for information regarding the US Environmental Protection Agency (EPA) and the California Emission Control Regulation of emission systems, maintenance, and warranty. Replacements may be ordered through the engine manufacturer.

Introduction

This rotary-blade, riding lawn mower is intended to be used by professional, hired operators or residential homeowners. It is designed primarily for cutting grass on well-maintained lawns on residential or commercial properties. It is not designed for cutting brush or for agricultural uses.

Read this information carefully to learn how to operate and maintain your product properly and to avoid injury and product damage. You are responsible for operating the product properly and safely.

You may contact Toro directly at www.Toro.com for product and accessory information, help finding a dealer, or to register your product.

Whenever you need service, genuine Toro parts, or additional information, contact an Authorized Service Dealer or Toro Customer Service and have the model and serial numbers of your product ready. Figure 1 identifies the location of the model and serial numbers on the product. Write the numbers in the space provided.

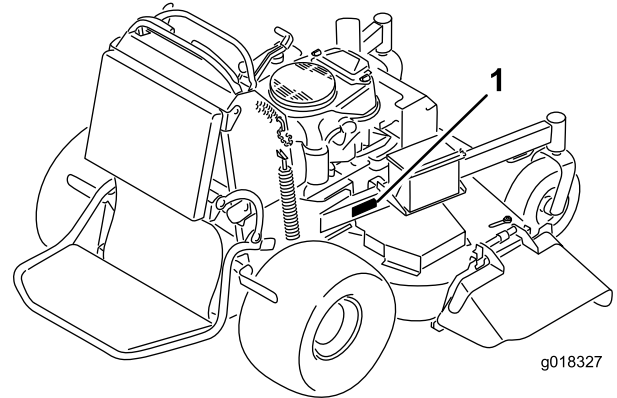

Figure 1

1. Location of the model and serial numbers

Model No. _____
Serial No. _____

This manual identifies potential hazards and has safety messages identified by the following words:

- **Danger** signals an extreme hazard that **will** cause serious injury or death if you do not follow the recommended precautions.
- **Warning** signals a hazard that **may** cause serious injury or death if you do not follow the recommended precautions.
- **Caution** signals a hazard that may cause minor or moderate injury if you do not follow the recommended precautions.

This manual uses two other words to highlight information. **Important** calls attention to special mechanical information and **Note** emphasizes general information worthy of special attention.

Contents

Introduction	2	Servicing the Battery	37
Safety	4	Servicing the Fuses	39
Safe Operating Practices	4	Drive System Maintenance	39
Toro Mower Safety	5	Adjusting the Tracking	39
Slope Indicator	7	Checking the Tire Pressure	40
Safety and Instructional Decals	8	Adjusting the Caster Pivot Bearing	41
Product Overview	12	Servicing the Caster Wheel and Bearings	41
Controls	13	Adjusting the Electric Clutch	42
Specifications	14	Cooling System Maintenance	42
Operation	15	Cleaning the Air Intake Screen	42
Adding Fuel	15	Cleaning the Cooling System	42
Checking the Engine Oil Level	16	Cleaning the Hydraulic Oil Cooler (52 and 60 inch Mower Models Only)	42
Breaking In a New Machine	16	Servicing the Hydraulic Oil Cooler (52 and 60 inch Mower Models Only)	43
Think Safety First	16	Brake Maintenance	43
Operating the Parking Brake	16	Servicing the Brake	43
Operating the Mower Blade Control Switch (PTO)	17	Belt Maintenance	45
Operating the Throttle	17	Replacing the Mower Deck Belt	45
Operating the Choke	17	Replacing the Pump Drive Belt	46
Operating the Ignition Switch	18	Controls System Maintenance	47
Using the Fuel Shut-Off Valve	18	Adjusting the Motion Control Handle Positions	47
Starting and Stopping the Engine	18	Hydraulic System Maintenance	50
The Safety Interlock System	19	Servicing the Hydraulic System	50
Operating the Platform	20	Mower Deck Maintenance	53
Driving Forward or Backward	21	Servicing the Cutting Blades	53
Stopping the Machine	22	Correcting the Mower Quality of Cut	54
Using the Rotation Indicator	22	Adjusting the Deck Lift Spring	57
Pushing the Machine by Hand	22	Replacing the Grass Deflector	58
Transporting Machines	23	Cleaning	59
Loading Machines	23	Cleaning Under the Mower	59
Side Discharging or Mulching the Grass	24	Waste Disposal	59
Adjusting the Height-of-Cut	24	Storage	59
Adjusting the Anti-Scalp Rollers (60 inch Mower Decks Only)	25	Cleaning and Storage	59
Adjusting the Flow Baffle	25	Troubleshooting	61
Positioning the Flow Baffle	25	Schematics	63
Using the Mid-Size Weight	26		
Maintenance	27		
Recommended Maintenance Schedule(s)	27		
Pre-maintenance Procedures	28		
Raising the Mower for Access	28		
Release the Cushion for Rear Access	29		
Lubrication	30		
How to Grease	30		
Lubricating the Machine	30		
Greasing the Front Caster Pivots	30		
Lubricate Caster Wheel Hubs	30		
Engine Maintenance	32		
Servicing the Air Cleaner	32		
Servicing the Engine Oil	32		
Servicing the Spark Plug	35		
Check Spark Arrestor (if equipped)	36		
Fuel System Maintenance	36		
Draining the Fuel Tank	36		
Servicing the Fuel Filter	37		
Electrical System Maintenance	37		

Safety

Note: The addition of attachments made by other manufacturers that do not meet American National Standards Institute certification will cause noncompliance of this machine.

Improper use or maintenance by the operator or owner can result in injury. To reduce the potential for injury, comply with these safety instructions and always pay attention to



the safety alert symbol, which means CAUTION, WARNING, or DANGER—"personal safety instruction." Failure to comply with the instruction may result in personal injury or death.

Safe Operating Practices

The following instructions are from ANSI standard B71.4-2012.

Training

- Read the Operator's Manual and other training material. If the operator(s) or mechanic(s) can not read English it is the owner's responsibility to explain this material to them.
- Become familiar with the safe operation of the equipment, operator controls, and safety signs.
- All operators and mechanics should be trained. The owner is responsible for training the users.
- Never let children or untrained people operate or service the equipment. Local regulations may restrict the age of the operator.
- The owner/user can prevent and is responsible for accidents or injuries occurring to himself or herself, other people or property.

Preparation

- Evaluate the terrain to determine what accessories and attachments are needed to properly and safely perform the job. Only use accessories and attachments approved by the manufacturer.
- Wear appropriate clothing including hard hat, safety glasses and hearing protection. Long hair, loose clothing or jewelry may get tangled in moving parts.
- Inspect the area where the equipment is to be used and remove all objects such as rocks, toys and wire which can be thrown by the machine.
- Check that operator's presence controls, safety switches and shields are attached and functioning properly. Do not operate unless they are functioning properly.

Operation

- Lightning can cause severe injury or death. If lightning is seen or thunder is heard in the area, do not operate the machine; seek shelter.
- Never run an engine in an enclosed area.
- Only operate in good light, keeping away from holes and hidden hazards.
- Be sure all drives are in neutral and parking brake is engaged before starting engine. Only start engine from the operator's position.
- Be sure of your footing while using this machine, especially when backing up. Walk, don't run. Never operate on wet grass. Reduced footing could cause slipping.
- Slow down and use extra care on hillsides. Be sure to travel side to side on hillsides. Turf conditions can affect the machine's stability. Use caution while operating near drop-offs.
- Slow down and use caution when making turns and when changing directions on slopes.
- Never raise deck with the blades running.
- Never operate with the PTO shield, or other guards not securely in place. Be sure all interlocks are attached, adjusted properly, and functioning properly.
- Never operate with the discharge deflector raised, removed or altered, unless using a grass catcher.
- Do not change the engine governor setting or overspeed the engine.
- Stop on level ground, disengage drives, engage parking brake (if provided), shut off engine before leaving the operator's position for any reason including emptying the catchers or unclogging the chute.
- Stop equipment and inspect blades after striking objects or if an abnormal vibration occurs. Make necessary repairs before resuming operations.
- Keep hands and feet away from the cutting unit.
- Look behind and down before backing up to be sure of a clear path.
- Keep pets and bystanders away.
- Slow down and use caution when making turns and crossing roads and sidewalks. Stop blades if not mowing.
- Be aware of the mower discharge direction and do not point it at anyone.
- Do not operate the mower under the influence of alcohol or drugs.
- Use care when loading or unloading the machine into or from a trailer or truck.
- Use care when approaching blind corners, shrubs, trees, or other objects that may obscure vision.
- Lightning can cause severe injury or death. If lightning is seen or thunder is heard in the area, do not operate the machine; seek shelter.

Safe handling of fuels

- To avoid personal injury or property damage, use extreme care in handling gasoline. Gasoline is extremely flammable and the vapors are explosive.
- Extinguish all cigarettes, cigars, pipes, and other sources of ignition.
- Use only an approved fuel container.
- Never remove fuel cap or add fuel with the engine running.
- Allow engine to cool before refueling.
- Never refuel the machine indoors.
- Never store the machine or fuel container where there is an open flame, spark, or pilot light such as on a water heater or on other appliances.
- Never fill containers inside a vehicle or on a truck or trailer bed with a plastic liner. Always place containers on the ground away from your vehicle before filling.
- Remove equipment from the truck or trailer and refuel it on the ground. If this is not possible, then refuel such equipment with a portable container, rather than from a fuel dispenser nozzle.
- Keep the nozzle in contact with the rim of the fuel tank or container opening at all times until fueling is complete. Do not use a nozzle lock open device.
- If fuel is spilled on clothing, change clothing immediately.
- Never overfill fuel tank. Replace fuel cap and tighten securely.

Maintenance and storage

- Disengage drives, set parking brake, stop engine and remove key or disconnect spark plug wire. Wait for all movement to stop before adjusting, cleaning or repairing.
- Clean grass and debris from cutting unit, drives, mufflers, and engine to help prevent fires. Clean up oil or fuel spillage.
- Let engine cool before storing and do not store near flame.
- Shut off fuel while storing or transporting. Do not store fuel near flames or drain indoors.
- Park machine on level ground. Set parking brake. Never allow untrained personnel to service machine.
- Use jack stands to support components when required.
- Carefully release pressure from components with stored energy.
- Disconnect the battery or remove spark plug wire before making any repairs. Disconnect the negative terminal first and the positive last. Reconnect the positive first and negative last.
- Use care when checking blades. Wrap the blade(s) or wear gloves, and use caution when servicing them. Only replace blades. Never straighten or weld them.

- Keep hands and feet away from moving parts. If possible, do not make adjustments with the engine running.
- Keep all parts in good working condition and all hardware tightened. Replace all worn or damaged decals.

Hauling

- Use care when loading or unloading the machine into a trailer or truck.
- Use full width ramps for loading machine into trailer or truck.
- Tie the machine down securely using straps, chains, cable, or ropes. Both front and rear straps should be directed down and outward from the machine.

Toro Mower Safety

The following list contains safety information specific to Toro products and other safety information you must know.

This product is capable of amputating hands and feet and throwing objects. Always follow all safety instructions to avoid serious injury or death.

This product is designed for cutting and recycling grass or, when equipped with a grass bagger, for catching cut grass. Any use for purposes other than these could prove dangerous to user and bystanders.

General Operation

- Be sure the area is clear of other people before mowing. Stop the machine if anyone enters the area.
- Do not touch equipment or attachment parts which may be hot from operation. Allow to cool before attempting to maintain, adjust or service.
- Use only Toro approved attachments. Warranty may be voided if used with unapproved attachments.
- Check carefully for overhead clearances (i.e. branches, doorways, electrical wires) before operating under any objects and do not contact them.
- Slow down before making turns and use extra caution.
- Use caution when riding the platform over curbs, rocks, roots, or other obstructions.
- Look behind and down before backing up to be sure of a clear path. Use extra care when operating in reverse.
- Never jerk the controls; use a steady motion.
- When loading or unloading the machine, use one full width ramp that is wide enough to extend beyond the width of the machine.
- Never carry passengers.
- Never carry cans or equipment on the machine.

Slope Operation

All slopes and ramps require extra caution. If you feel uneasy on a slope, do not mow it.

- Remove obstacles such as rocks, tree limbs, etc. from the mowing area.
- Watch for holes, ruts or bumps. Tall grass can hide obstacles.
- Use caution near drop-offs, ditches, or embankments. The machine could suddenly turn over if a wheel goes over the edge of a cliff or ditch, or if an edge caves in.
- Use extra care with grass catchers or other attachments. These can change the stability of the machine.
- Keep all movement on slopes slow and gradual. Do not make sudden changes in speed or direction.
- Mow slopes side to side.
- Do not mow slopes greater than 20 degrees.

Service

- Never store the machine or fuel container inside where there is an open flame, such as near a water heater or furnace.
- Keep nuts and bolts tight, especially the blade attachment bolts. Keep equipment in good condition.
- Never tamper with safety devices. Check safety systems for proper operation before each use.
- Use only genuine replacement parts to ensure that original standards are maintained.
- Check brake operation frequently. Adjust and service as required.

Slope Indicator



G011841

2

Figure 2

This page may be copied for personal use.

1. The maximum slope you can safely operate the machine on is **20 degrees**. Use the slope chart to determine the degree of slope of hills before operating. **Do not operate this machine on a slope greater than 20 degrees**. Fold along the appropriate line to match the recommended slope.
2. Align this edge with a vertical surface, a tree, building, fence pole, etc.
3. Example of how to compare slope with folded edge.

Safety and Instructional Decals



Safety decals and instructions are easily visible to the operator and are located near any area of potential danger. Replace any decal that is damaged or lost.

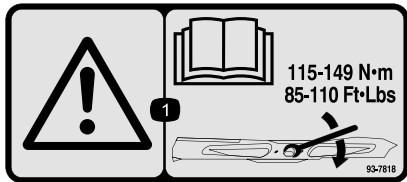

93-7818

1. Warning—read the *Operator's Manual* for instructions on torquing the blade bolt/nut to 85-110 ft-lb (115-149 N-m).



Battery Symbols

Some or all of these symbols are on your battery

- | | |
|--|--|
| 1. Explosion hazard | 6. Keep bystanders a safe distance from the battery. |
| 2. No fire, open flame, or smoking. | 7. Wear eye protection; explosive gases can cause blindness and other injuries |
| 3. Caustic liquid/chemical burn hazard | 8. Battery acid can cause blindness or severe burns. |
| 4. Wear eye protection | 9. Flush eyes immediately with water and get medical help fast. |
| 5. Read the <i>Operator's Manual</i> . | 10. Contains lead; do not discard. |



106-5517

1. Warning—do not touch the hot surface.

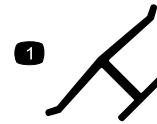

Manufacturer's Mark

1. Indicates the blade is identified as a part from the original machine manufacturer.

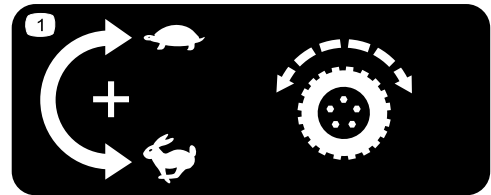

1. Cable adjustment lock for traction drive speed.

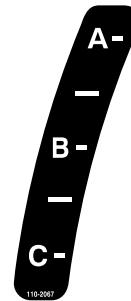

110-2067

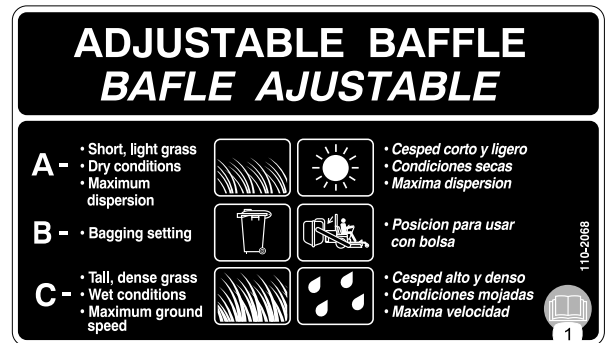

110-2068

1. Read the *Operator's Manual*.

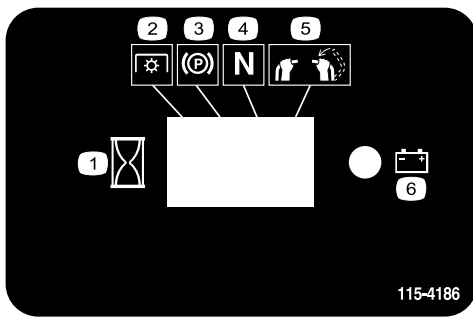

115-4186

1. Interval
2. Power Take-off (PTO)
3. Parking brake
4. Neutral
5. Operator presence switch
6. Battery



116-3290

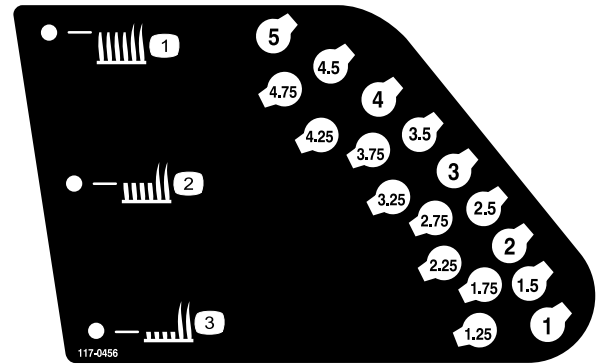

117-0456

1. Height of cut (HOC)—high
2. Height of cut (HOC)—medium
3. Height of cut (HOC)—low

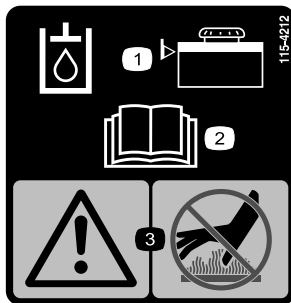

115-4212

1. Hydraulic oil level
2. Read the *Operator's Manual*.
3. Warning—do not touch the hot surface.



119-0217

1. Warning—stop the engine; stay away from moving parts; keep all guards and shields in place.



116-3267

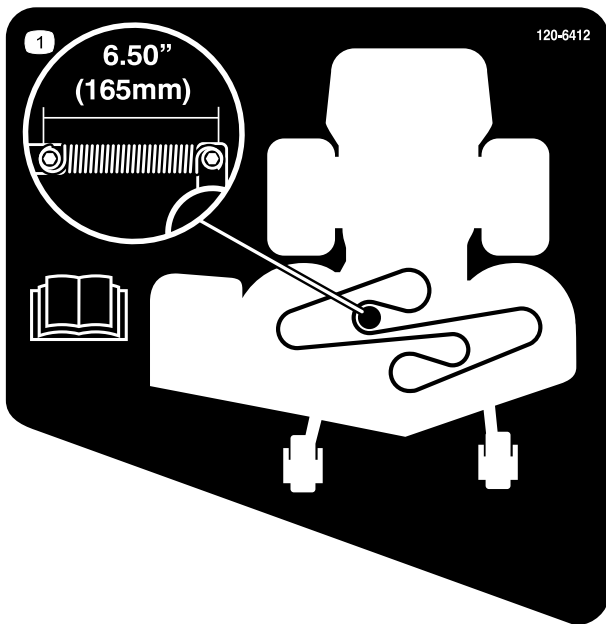

120-6412

1. Belt tension adjustment; read the *Operator's Manual* for more information.

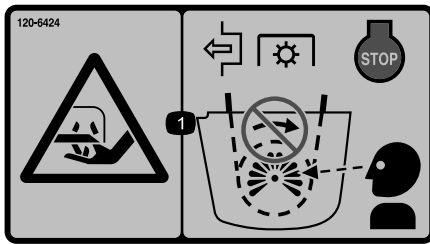

120-6424

1. Cutting/dismemberment hazard, hand—disengage the power take-off (PTO), stop the engine and watch for all moving parts to stop.



121-5972

1. Read the *Operator's Manual* before servicing or performing maintenance.

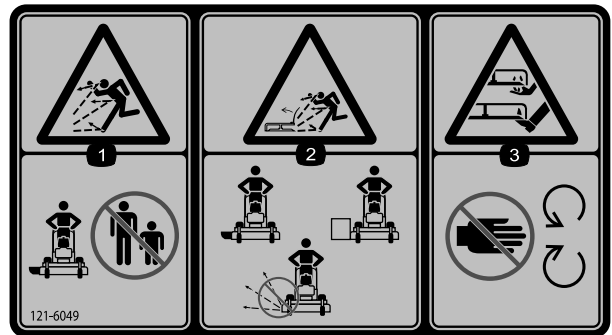

121-6049

1. Thrown object hazard—keep bystanders away from the machine.
2. Thrown object hazard, mower—do not operate the mower with guards or shields removed.
3. Cutting/dismemberment hazard of hand or foot, mower blade—keep hands away from moving parts.



117-3626

1. Warning—read the *Operator's Manual*.
2. Warning—do not operate this machine unless you are trained.
3. Thrown object hazard—keep deflector in place.
4. Cutting, dismemberment hazard of hand or foot—stay away from moving parts and keep all guards and shields in place.
5. Thrown object hazard—keep bystanders a safe distance from the machine.
6. Warning—engage the parking brake, stop the engine and remove the spark plug wire before performing any maintenance on the machine.
7. Warning—engage the parking brake and stop the engine before leaving the machine.
8. Sliding and loss of control hazard—do not operate the machine near drop-offs or water; keep a safe distance from drop-offs.

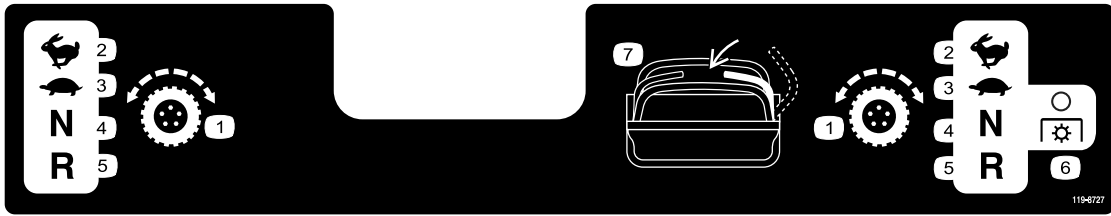

119-8727

- | | | | |
|---------------------|------------|-----------------------------------|-----------------------------|
| 1. Traction control | 3. Slow | 5. Reverse | 7. Operator presence switch |
| 2. Fast | 4. Neutral | 6. Power Take-off (PTO)—disengage | |

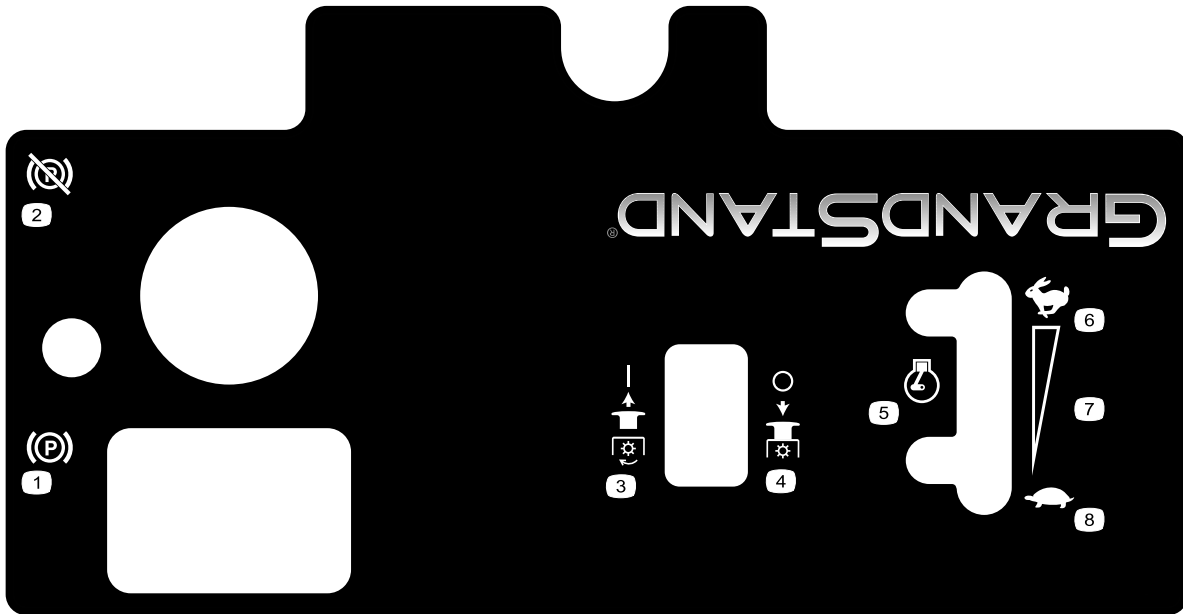

120-6464

- | | | | |
|----------------------------|-----------------------------------|-----------------|--------------------------------|
| 1. Parking brake—engage | 3. Power Take-off (PTO)—engage | 5. Engine speed | 7. Continuous variable setting |
| 2. Parking brake—disengage | 4. Power Take-off (PTO)—disengage | 6. Fast | 8. Slow |

Product Overview

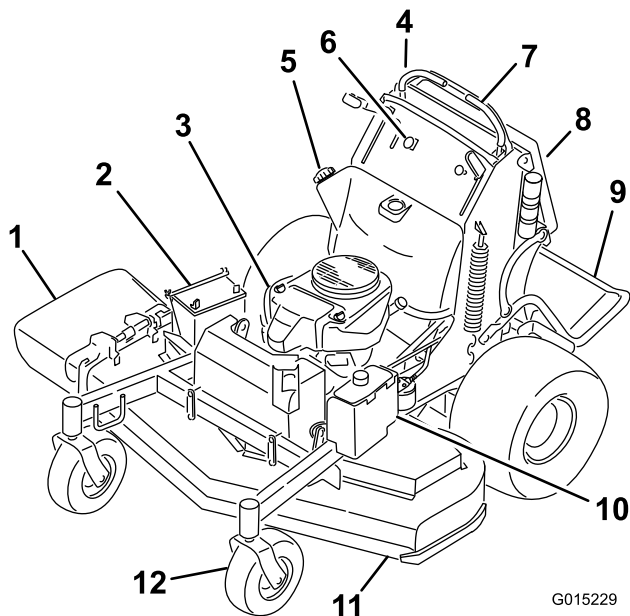

G015229

Figure 3

48 inch (shown) and 52 inch machines

- | | |
|---|-----------------------------|
| 1. Side discharge chute | 7. Control levers |
| 2. Battery | 8. Manual tube |
| 3. Engine | 9. Platform (down position) |
| 4. Fuel shut-off valve (behind cushion) | 10. Hydraulic tank |
| 5. Fuel tank | 11. Mower deck |
| 6. Controls | 12. Front caster wheel |

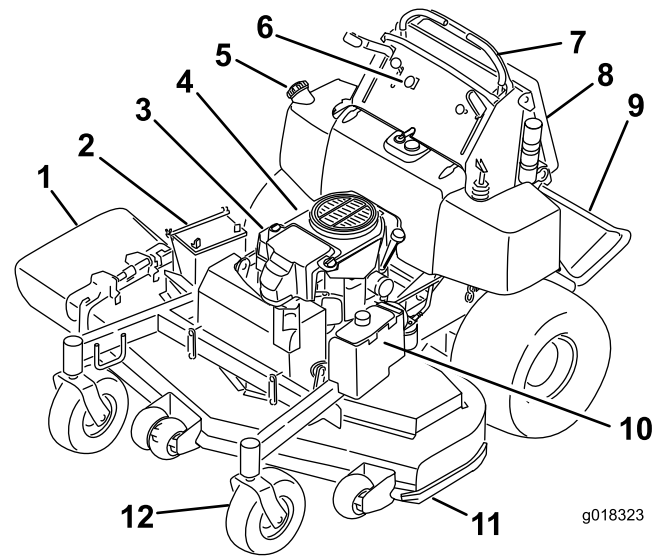

g018323

Figure 4

60 inch machine

- | | |
|---|-----------------------------|
| 1. Side discharge chute | 7. Control levers |
| 2. Battery | 8. Manual tube |
| 3. Engine | 9. Platform (down position) |
| 4. Fuel shut-off valve (behind cushion) | 10. Hydraulic tank |
| 5. Fuel tank | 11. Mower deck |
| 6. Controls | 12. Front caster wheel |

Controls

Become familiar with all the controls (Figure 5) before you start the engine and operate the machine.

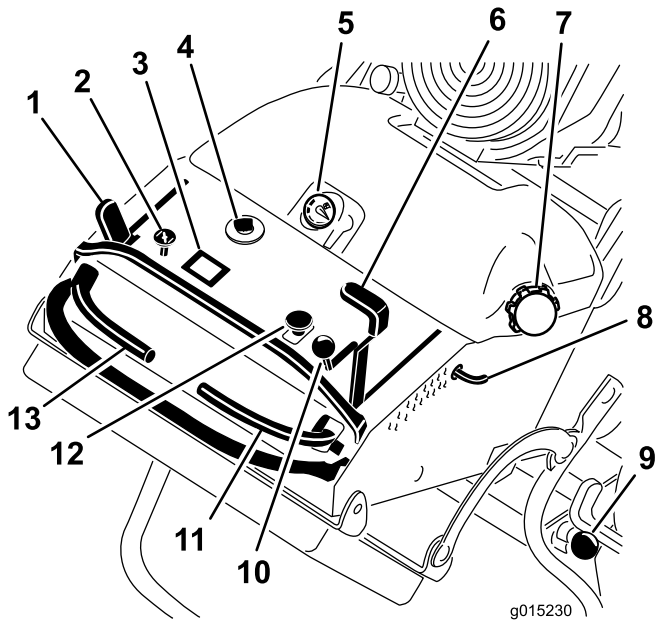

Figure 5

48 inch and 52 inch machines

- | | |
|------------------------|--------------------------------|
| 1. Parking brake lever | 8. Height-of-cut pin |
| 2. Choke | 9. Platform latch |
| 3. Hour meter | 10. Throttle control |
| 4. Ignition switch | 11. Right motion control lever |
| 5. Fuel gauge | 12. Blade control switch (PTO) |
| 6. Height-of-cut lever | 13. Left motion control lever |
| 7. Fuel cap | |

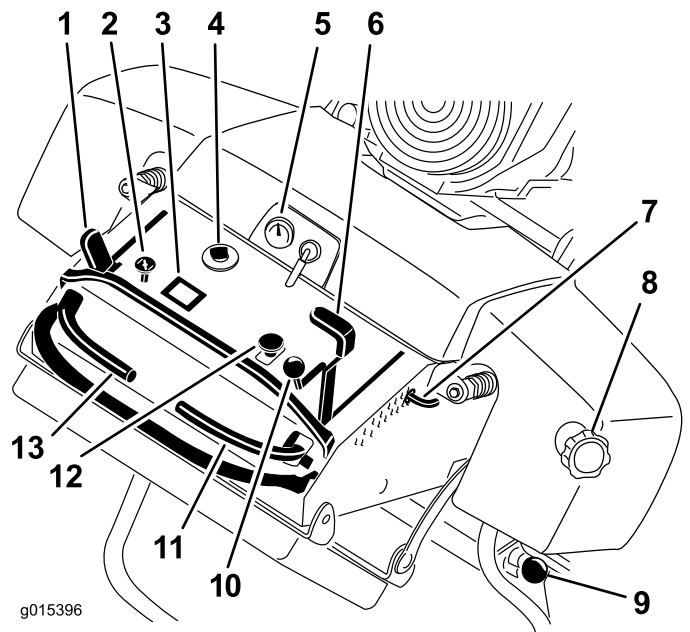

Figure 6

60 inch machine

- | | |
|------------------------|--------------------------------|
| 1. Parking brake lever | 8. Fuel cap |
| 2. Choke | 9. Platform latch |
| 3. Hour meter | 10. Throttle control |
| 4. Ignition switch | 11. Right motion control lever |
| 5. Fuel gauge | 12. Blade control switch (PTO) |
| 6. Height-of-cut lever | 13. Left motion control lever |
| 7. Height-of-cut pin | |

Hour Meter

The hour meter records the number of hours the engine has operated. It operates when the engine is running. Use these times for scheduling regular maintenance (Figure 7).

Fuel Gauge

The fuel gauge is located on the top, middle of the tank (Figure 5).

Safety Interlock Indicators

There are symbols on the hour meter and indicate with a black triangle that the interlock component is in the correct position (Figure 7).

Battery Indicator Light

If the ignition key is turned to the **On** position for a few seconds, the battery voltage will be displayed in the area where the hours are normally displayed.

The battery light turns on when the ignition is turned on and when the charge is below the correct operating level (Figure 7).

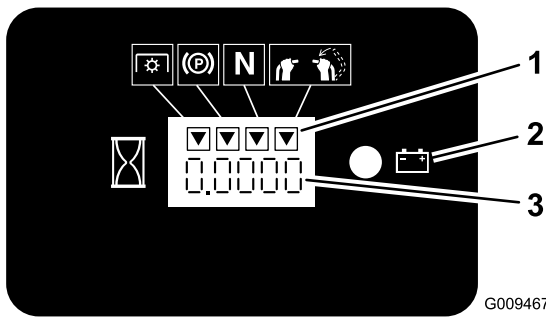

Figure 7

1. Safety interlock symbols
2. Battery light
3. Hour meter

Throttle Control

The throttle control is variable between **Fast** and **Slow**.

Choke

Use the choke to start a cold engine.

Blade Control Switch (PTO)

The blade control switch (PTO) is used to engage the electric clutch to drive the mower blades with the right side motion control lever in the center, un-locked position. Pull the switch up to engage the blades and release. To disengage the blades, push the blade control switch (PTO) down or move or release the right side motion control lever into the neutral lock position.

Ignition Switch

This switch is used to start the mower engine and has three positions: **Off**, **Run** and **Start**.

Motion Control Levers

The motion control levers are used to drive the machine forward, reverse, and turn either direction.

Fuel Shut-off Valve

Close the fuel shut-off valve (located behind the operator cushion on the right hand side of the fuel tank) when transporting or storing the mower.

Attachments/Accessories

A selection of Toro approved attachments and accessories are available for use with the machine to enhance and expand its capabilities. Contact your Authorized Service Dealer or Distributor or go to www.Toro.com for a list of all approved attachments and accessories.

Specifications

Note: Specifications and design are subject to change without notice.

48 inch mowers:

Width with deflector down	63.5 inches (161.3 cm)
Width with deflector raised	49.5 inches (125.7 cm)
Length with platform down	74 inches (188 cm)
Length with platform up	59 inches (149.9 cm)
Height	48 inches (121.9 cm)
Weight for model 74578	897 lbs (406.9 kg)
Weight for model 79548	903 lbs (409.6 kg)

52 inch mowers:

Width with deflector down	67.6 inches (171.7 cm)
Width with deflector raised	53.5 inches (135.9 cm)
Length with platform down	74 inches (188 cm)
Length with platform up	59 inches (149.9 cm)
Height	48 inches (121.9 cm)
Weight for model 74549	908 lbs (411.9 kg)
Weight for model 79549	914 lbs (414.6 kg)

60 inch mowers:

Width with deflector down	75.6 inches (192.0 cm)
Width with deflector raised	61.5 inches (156.2 cm)
Length with platform down	77.9 inches (197.9 cm)
Length with platform up	62.9 inches (159.8 cm)
Height	48 inches (121.9 cm)
Weight for model 74553	924 lbs (419.1 kg)
Weight for model 79553	930 lbs (421.8 kg)

Operation

Note: Determine the left and right sides of the machine from the normal operating position.

Adding Fuel

- For best results, use only clean, fresh, unleaded gasoline with an octane rating of 87 or higher ((R+M)/2 rating method).
- Oxygenated fuel with up to 10% ethanol or 15% MTBE by volume is acceptable.
- **Do Not** use ethanol blends of gasoline (such as E15 or E85) with more than 10% ethanol by volume. Performance problems and/or engine damage may result which may not be covered under warranty.
- **Do Not** use gasoline containing methanol.
- **Do Not** store fuel either in the fuel tank or fuel containers over the winter unless a fuel stabilizer is used.
- **Do Not** add oil to gasoline.

▲ DANGER

In certain conditions, gasoline is extremely flammable and highly explosive. A fire or explosion from gasoline can burn you and others and can damage property.

- Fill the fuel tank outdoors on level ground, in an open area, when the engine is cold. Wipe up any gasoline that spills.
- Never fill the fuel tank inside an enclosed trailer.
- Do not fill the fuel tank completely full. Fill the fuel tank to the bottom of the filler neck. The empty space in the tank allows gasoline to expand. Overfilling may result in fuel leakage or damage to the engine or emission system (if equipped).
- Never smoke when handling gasoline, and stay away from an open flame or where gasoline fumes may be ignited by a spark.
- Store gasoline in an approved container and keep it out of the reach of children. Never buy more than a 30-day supply of gasoline.
- Do not operate without entire exhaust system in place and in proper working condition.

▲ DANGER

In certain conditions during fueling, static electricity can be released causing a spark which can ignite the gasoline vapors. A fire or explosion from gasoline can burn you and others and can damage property.

- Always place gasoline containers on the ground away from your vehicle before filling.
- Do not fill gasoline containers inside a vehicle or on a truck or trailer bed because interior carpets or plastic truck bed liners may insulate the container and slow the loss of any static charge.
- When practical, remove gas-powered equipment from the truck or trailer and refuel the equipment with its wheels on the ground.
- If this is not possible, then refuel such equipment on a truck or trailer from a portable container, rather than from a gasoline dispenser nozzle.
- If a gasoline dispenser nozzle must be used, keep the nozzle in contact with the rim of the fuel tank or container opening at all times until fueling is complete.

▲ WARNING

Gasoline is harmful or fatal if swallowed. Long-term exposure to vapors can cause serious injury and illness.

- Avoid prolonged breathing of vapors.
- Keep face away from nozzle and gas tank or conditioner opening.
- Keep gas away from eyes and skin.

Using Stabilizer/Conditioner

Use a fuel stabilizer/conditioner in the machine to provide the following benefits:

- Keeps gasoline fresh during storage of 90 days or less. For longer storage it is recommended that the fuel tank be drained.
- Cleans the engine while it runs
- Eliminates gum-like varnish buildup in the fuel system, which causes hard starting

Important: Do not use fuel additives containing methanol or ethanol.

Add the correct amount of gas stabilizer/conditioner to the gas.

Note: A fuel stabilizer/conditioner is most effective when mixed with fresh gasoline. To minimize the chance

of varnish deposits in the fuel system, use fuel stabilizer at all times.

Filling the Fuel Tank

Note: Do not fill the fuel tank completely full. Fill the fuel tank to the bottom of the filler neck. The empty space in the tank allows the gasoline to expand.

1. Park the machine on level ground.
2. Shut the engine off and set the parking brake.
3. Clean around the fuel tank cap.
4. Fill the fuel tank to the bottom of the filler neck. Ensure there is empty space in the tank to allow the gasoline to expand Figure 8.

Note: Ensure the fuel shut off valve is open before starting the machine.

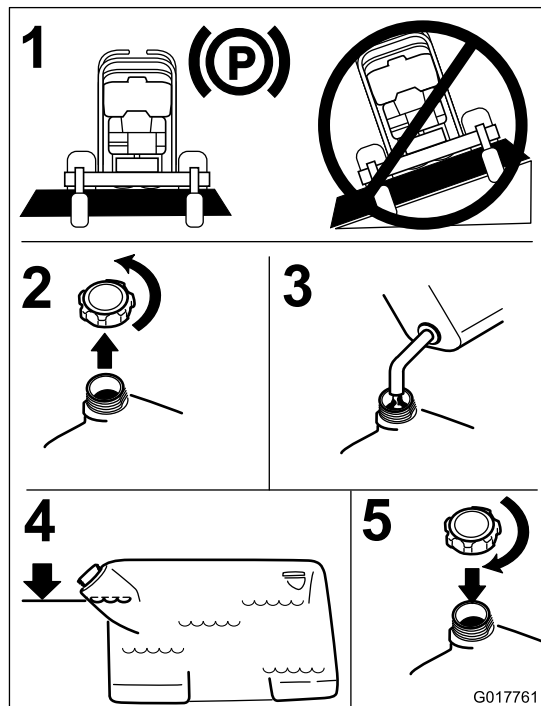
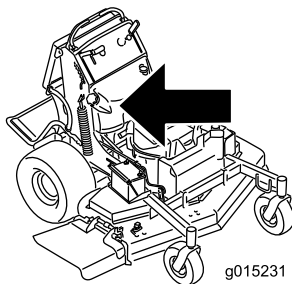

Figure 8

Checking the Engine Oil Level

Before you start the engine and use the machine, check the oil level in the engine crankcase; refer to Checking Oil Level in Engine Maintenance.

Breaking In a New Machine

New engines take time to develop full power. Mower decks and drive systems have higher friction when new, placing additional load on the engine. Allow 40 to 50 hours of break-in time for new machines to develop full power and best performance.

Think Safety First

Carefully read all the safety instructions and decals in the safety section. Knowing this information could help you or any bystanders avoid injury.

The use of protective equipment for eyes, hearing, feet and head is recommended.

⚠ CAUTION

This machine produces sound levels in excess of 85 dBA at the operator's ear and can cause hearing loss through extended periods of exposure.

Wear hearing protection when operating this machine.

Operating the Parking Brake

Always set the parking brake when you stop the machine or leave it unattended. Before each use, check the parking brake for proper operation.

If the parking brake does not hold securely, adjust it. Refer to Servicing the Parking Brake.

⚠ CAUTION

Children or bystanders may be injured if they move or attempt to operate the machine while it is unattended.

Always remove the ignition key and set the parking brake when leaving the machine unattended, even if just for a few minutes.

Setting the Parking Brake

Pull the parking brake lever rearward and over into engaged position (Figure 9).

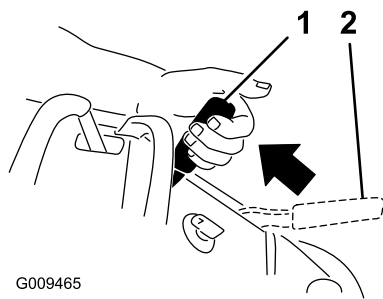

Figure 9

1. Parking brake engaged
2. Parking brake released

Releasing the Parking Brake

Pull the brake lever back and over into the slot and push the parking brake lever forward.

Operating the Mower Blade Control Switch (PTO)

The blade control switch (PTO) is used in conjunction with the right side motion control lever to engage and disengage the mower blades.

Engaging the Mower Blades (PTO)

1. To engage the mower blades, move the right side motion control lever to the center, un-locked position.
2. Pull the blade control switch (PTO) up and release it while holding down the right side motion control lever in the center, un-locked position.

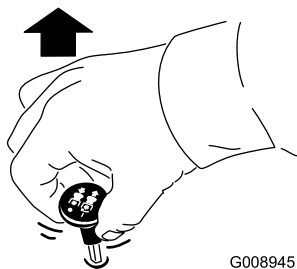

Figure 10

Disengaging the Mower Blades (PTO)

The following are two options for disengaging the mower blades.

- Push the blade control switch (PTO) down to the off position.
- Move the motion control levers to neutral and move the right side motion control lever into the neutral lock position.

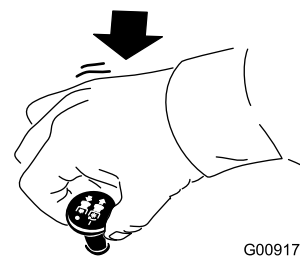

Figure 11

Operating the Throttle

The throttle control can be moved between **Fast** and **Slow** positions (Figure 12).

Always use the fast position when turning on the mower deck with the blade control switch (PTO).

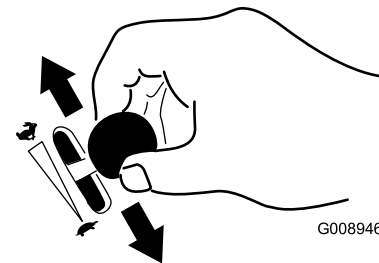

Figure 12

Operating the Choke

Use the choke to start a cold engine.

1. If the engine is cold, use the choke to start the engine.
2. Pull up on the choke knob to engage the choke before using the ignition switch (Figure 13).
3. Push down on the choke to disengage the choke after the engine has started (Figure 13).

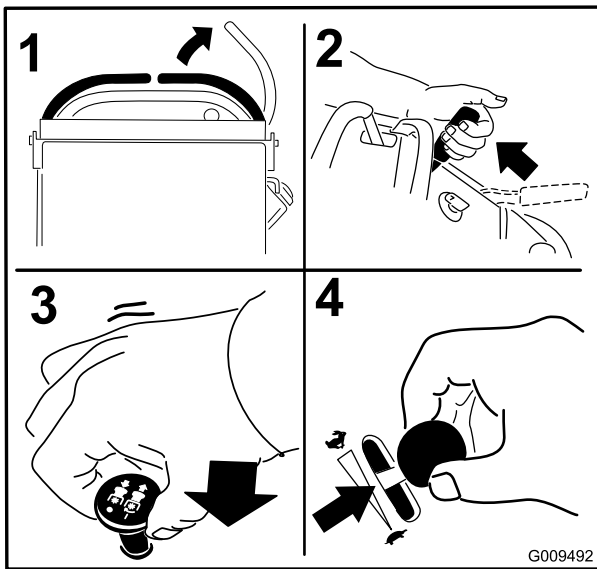

Figure 16

- Turn the ignition key to the Start position (Figure 14). When the engine starts, release the key.

Important: Do not engage starter for more than 5 seconds at a time. If the engine fails to start allow a 15 second cool-down period between attempts. Failure to follow these instructions can burn out the starter motor.

Note: Additional starting cycles may be required when starting the engine for the first time after the fuel system has been without fuel completely.

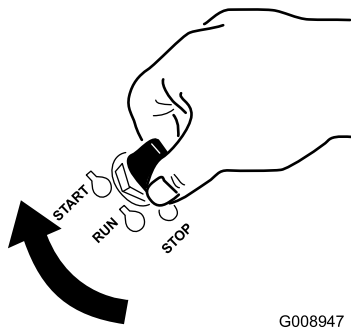

Figure 17

- Off
- Run
- Start

Stopping the Engine

⚠ CAUTION

Children or bystanders may be injured if they move or attempt to operate the tractor while it is unattended.

Always remove the ignition key and set the parking brake when leaving the machine unattended, even if just for a few minutes.

Let the engine idle at slow throttle (turtle) for 60 seconds before turning the ignition switch off.

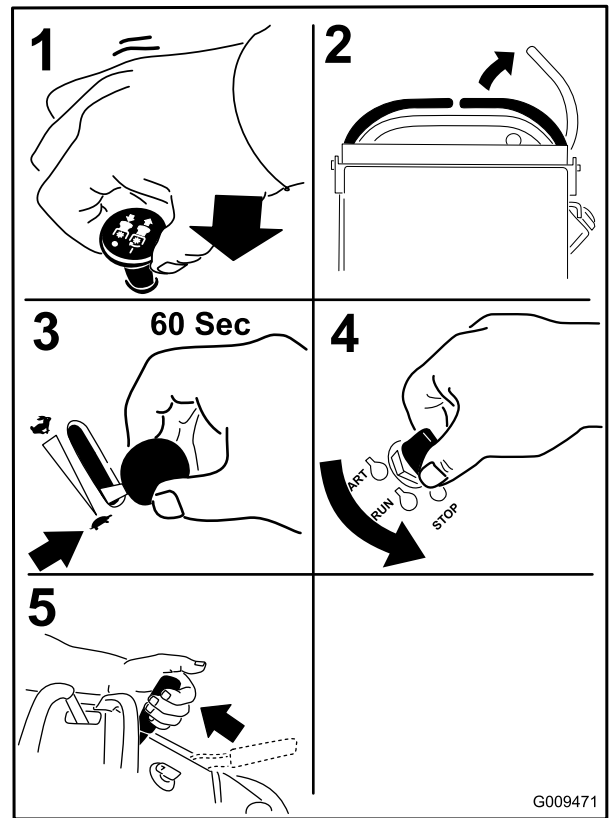

Figure 18

Important: Make sure fuel shut off valve is closed before transporting or storing the machine, as fuel leakage may occur. Before storing the machine, pull wire off spark plug(s) to prevent possibility of accidental starting.

The Safety Interlock System

⚠ CAUTION

If safety interlock switches are disconnected or damaged the machine could operate unexpectedly causing personal injury.

- Do not tamper with the interlock switches.
- Check the operation of the interlock switches daily and replace any damaged switches before operating the machine.

Understanding the Safety Interlock System

The safety interlock system is designed to prevent the mower blades from rotating unless:

- The right side motion control lever is moved to the center, un-locked position.
- The blade control switch (PTO) is pulled on.

The safety interlock system is designed to stop the mower blades if you move or release the right side motion control lever into the neutral lock position.

The hour meter has symbols to notify the user when the interlock component is in the correct position. When the component is in the correct position, a triangle will light up in the corresponding square.

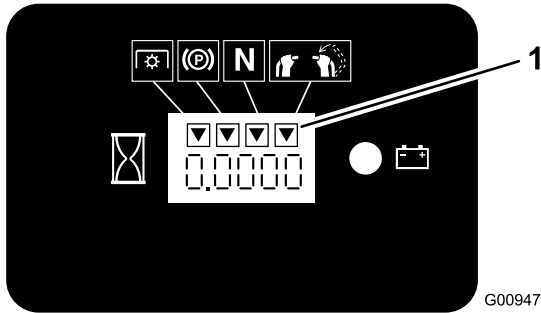

Figure 19

1. Triangles light up when the interlock components are in the correct position

Testing the Safety Interlock System

Service Interval: Before each use or daily

Test the safety interlock system before you use the machine each time.

Note: If the safety system does not operate as described below, have an Authorized Service Dealer repair the safety system immediately.

1. Start the engine; refer to Starting and Stopping the Engine in Starting and Stopping the Engine (page 18).
2. Set the parking brake.
3. Move the right side motion control lever to the center, un-locked position. **The blades should not rotate.**
4. Move the motion control levers forward. **The engine should kill.**
5. Start the engine and release the parking brake.
6. Move the right side motion control lever to the center, un-locked position.
7. Continue holding the right side motion control lever in the center, un-locked position and pull up on the blade control switch (PTO) and release. The clutch should engage and the mower blades begin rotating.
8. Move or release the right side motion control lever into the neutral lock position. **The blades should stop rotating and the engine continues to run.**
9. Push the blade control switch down and move the right side motion control lever to the center, un-locked position.
10. Continue holding the right side motion control lever in the center, un-locked position and pull up on the blade

control switch (PTO) and release. The clutch should engage and the mower blades begin rotating.

11. Push the blade control switch (PTO) down to the off position. **The blades should stop rotating.**
12. With the engine running, pull up the blade control switch (PTO) and release without holding right side motion control lever to the center, un-locked position. **The blades should not rotate.**

▲ WARNING

The operator platform is heavy and may cause injury when lowering and raising the operator platform. The platform may suddenly drop if not supported when the latch pin is pulled out.

- Do not put hands or fingers in the platform pivot area when lowering or raising the operator platform.
- Make sure the platform is supported when the latch pin is pulled out.
- Make sure the latch secures the platform when folding it in the up position. Push it tight against the cushion for the latch pin to lock into place.
- Keep bystanders away when raising or lowering the platform.

Operating the Platform

The machine can be used with the platform in the up or down position. It is the operator's preference on which position to use.

Operating the Machine with the Platform Up

Operating the machine with the platform up is recommended when:

- Mowing near drop-off's
- Mowing small areas where the machine is too long
- Areas with low over hanging branches or obstacles
- Loading the machine for transport
- Driving up slopes

To raise the platform, pull the back of the platform up so the latch pin and knob lock it into place. Push it tight against the cushion for the latch pin to lock into place.

Operating the Machine with the Platform Down

Operating the machine with the platform down is recommended when:

- Mowing most areas
- Driving across slopes
- Driving down slopes

To lower the platform, push the platform forward against the cushion to release pressure on the latch pin and then pull the knob out and lower the platform.

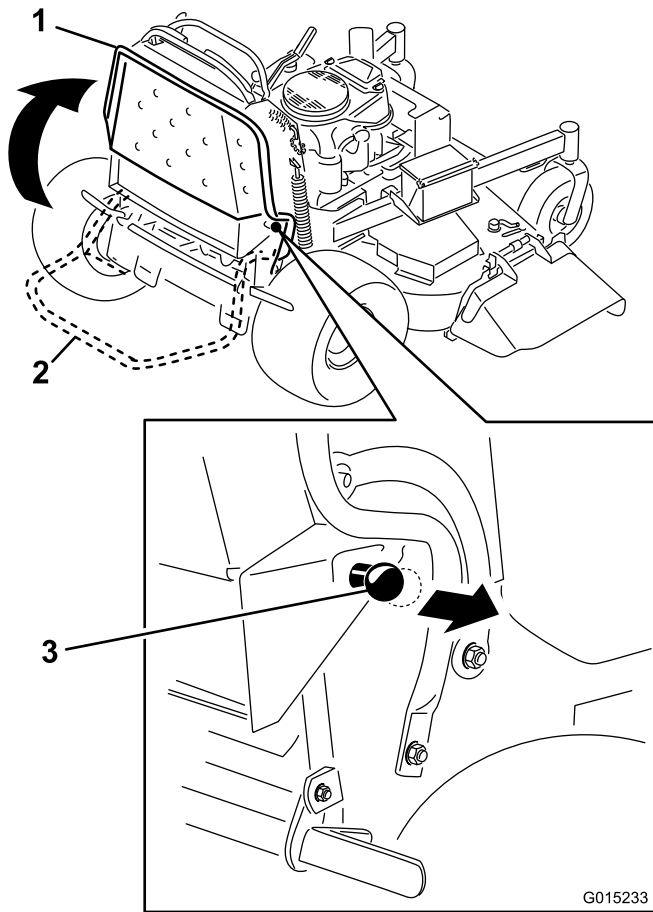

Figure 20

- | | |
|------------------|--|
| 1. Platform up | 3. Pull the knob out to release the platform |
| 2. Platform down | |

Driving Forward or Backward

The throttle control regulates the engine speed as measured in rpm (revolutions per minute). Place the throttle control in the fast position for best performance. Always operate in the full throttle position when mowing.

CAUTION

Machine can spin very rapidly. Operator may lose control of machine and cause personal injury or damage to machine.

Slow the machine down before making sharp turns.

Driving Forward

1. Release the parking brake; refer to Releasing the Parking Brake in Operation.
2. Move the right side motion control lever to the center, un-locked position.

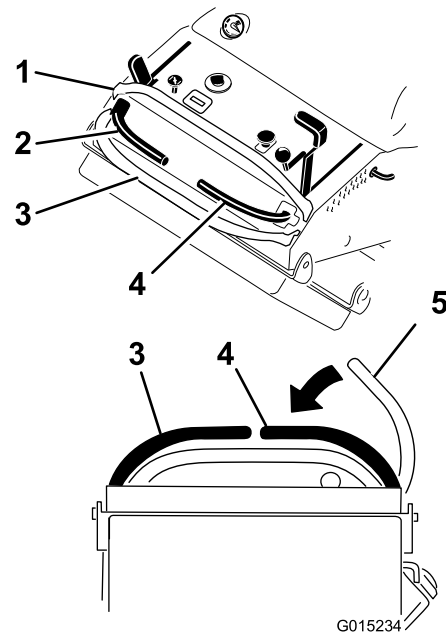

Figure 21

- | | |
|------------------------|---|
| 1. Front reference bar | 4. Right control lever |
| 2. Left control lever | 5. Right control lever in the neutral lock position |
| 3. Rear reference bar | |

3. To go forward, move the speed control lever to the desired speed.
4. Slowly push the motion control levers forward (Figure 22).

Note: The engine will kill if a motion control lever is moved with the parking brake engaged.

The farther you move the motion control levers in either direction, the faster the machine will move in that direction.

To stop, pull the motion control levers back to the neutral position.

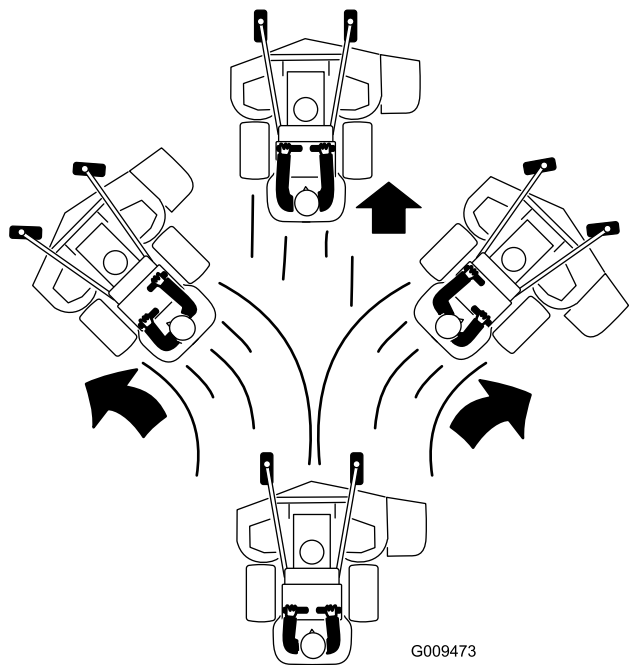

Figure 22

Set the parking brake when you leave the machine; refer to Setting the Parking Brake in Operation. Remember to remove the key from the ignition switch.

⚠ CAUTION

Children or bystanders may be injured if they move or attempt to operate the tractor while it is unattended.

Always remove the ignition key and set the parking brake when leaving the machine unattended, even if just for a few minutes.

Using the Rotation Indicator

The slots in the top of the belt covers allow the operator to verify if the blades have stopped rotating after disengaging the power take-off (PTO) switch.

Disengage the power take-off (PTO) switch, stop the engine, remove the key, and wait for all moving parts to stop before leaving the operating position.

Driving Backward

1. Move the right side motion control lever to the center, un-locked position.
2. Slowly pull the motion control levers rearward (Figure 23).

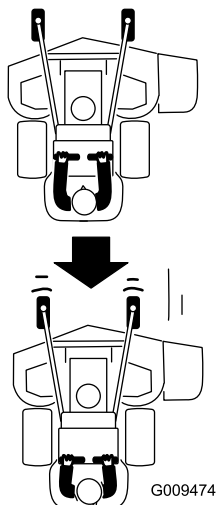

Figure 23

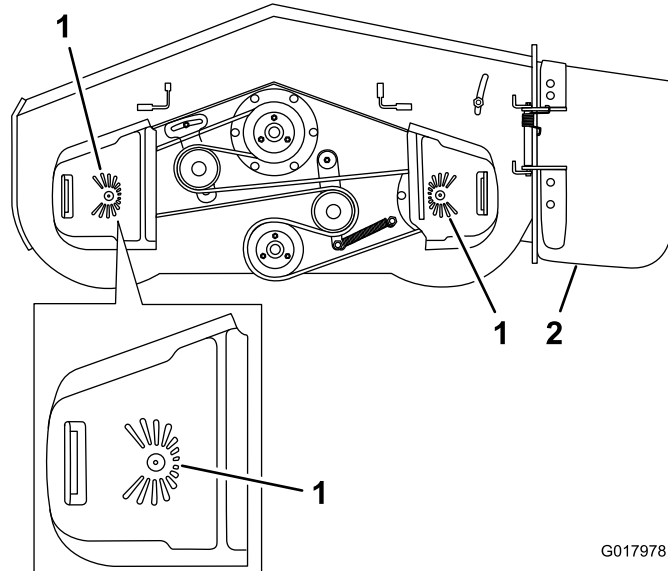

Figure 24

52 inch mower deck shown

1. Rotation Indicator - slots in the top of the belt cover
2. Side discharge chute

Stopping the Machine

To stop the machine, move the motion control levers to neutral, move the right side motion control lever into the neutral lock position, disengage the power take off (PTO), and turn the ignition key to off.

Pushing the Machine by Hand

The by-pass valves allow the machine to be pushed by hand without the engine running.

Important: Always push the machine by hand. Never tow the machine because hydraulic damage may occur.

To Push the Machine

1. Disengage the PTO, move the motion control levers to the neutral locked position and set the parking brake.

- Open the by-pass valve on both pumps by turning them counter clockwise 1 to 2 turns. This allows hydraulic fluid to by-pass the pumps and the wheels to turn (Figure 25).

Note: Rotate the by-pass valves a maximum of 2 turns so the valve does not come out of the body causing fluid to run out.

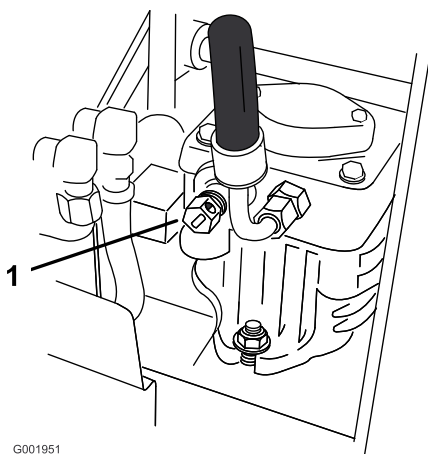

Figure 25

- Pump by-pass valve

- Release the parking brake.
- Push the machine to the desired location.
- Set the parking brake.
- Close the by-pass valves, but do not overtighten them. Torque to 110 to 130 in-lb (12 to 15 N-m).

Important: Do not start or operate the machine with the by-pass valves open. Damage to system may occur.

Transporting Machines

Use a heavy-duty trailer or truck to transport the machine. Ensure that the trailer or truck has all necessary brakes, lighting, and marking as required by law. Please carefully read all the safety instructions. Knowing this information could help you, your family, pets or bystanders avoid injury.

To transport the machine:

- Raise the platform of the machine before driving up onto the trailer or truck.
- If using a trailer, connect it to the towing vehicle and connect the safety chains.
- If applicable, connect the trailer brakes.
- Load the machine onto the trailer or truck.
- Stop the engine, remove the key, set the brake, and close the fuel valve.
- Use the metal tie down loops on the machine to securely fasten the machine to the trailer or truck with straps, chains, cable, or ropes (Figure 26).

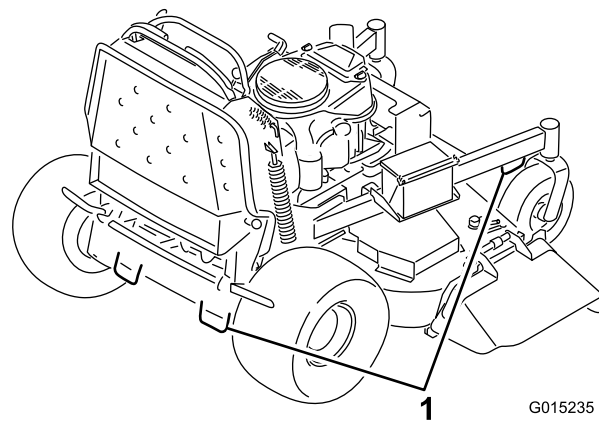

Figure 26

- Traction unit tie down loop

Loading Machines

Use extreme caution when loading units on trailers or trucks. One full width ramp that is wide enough to extend beyond the rear tires is recommended instead of individual ramps for each side of the unit (Figure 27). The platform when down and locked into position, extends back between the rear wheels and serves as a stop for tipping backward. Having a full width ramp provides a surface for the platform to contact if the unit starts to tip backward. With the platform up, a full width ramp provides a surface to walk on behind the unit. The operator should determine if it is best to have the platform up or down when loading, depending on conditions. If it is not possible to use one full width ramp, use enough individual ramps to simulate a full width continuous ramp.

The ramp should be long enough so that the angles do not exceed 20 degrees (Figure 27). A steeper angle may cause mower components to get caught as the unit moves from ramp to trailer or truck. Steeper angles may also cause the unit to tip backward. If loading on or near a slope, position the trailer or truck so it is on the down side of the slope and the ramp extends up the slope. This will minimize the ramp angle. The trailer or truck should be as level as possible.

Important: Do Not attempt to turn the unit while on the ramp; you may lose control and drive off the side.

Avoid sudden acceleration when driving up a ramp and sudden deceleration when backing down a ramp. Both maneuvers can cause the unit to tip backward.

⚠ WARNING

Loading a unit onto a trailer or truck increases the possibility of backward tip-over and could cause serious injury or death.

- Use extreme caution when operating a unit on a ramp.
- Use only a single, full width ramp; Do Not use individual ramps for each side of the unit.
- If individual ramps must be used, use enough ramps to create an unbroken ramp surface wider than the unit.
- Do not exceed a 20 degree angle between ramp and ground or between ramp and trailer or truck.
- Avoid sudden acceleration while driving unit up a ramp to avoid tipping backward.
- Avoid sudden deceleration while backing unit down a ramp to avoid tipping backward.

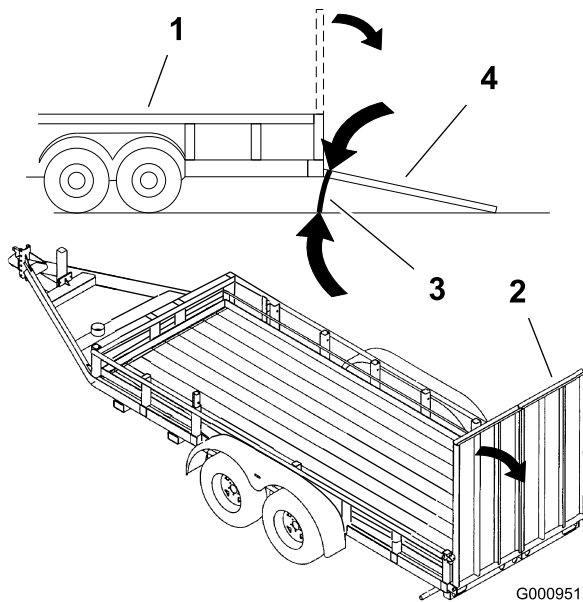

Figure 27

- | | |
|--------------------|--------------------------------|
| 1. Trailer | 3. Not greater than 20 degrees |
| 2. Full width ramp | 4. Full width ramp—side view |

Side Discharging or Mulching the Grass

This mower has a hinged grass deflector that disperses clippings to the side and down toward the turf.

⚠ DANGER

Without the grass deflector, discharge cover, or complete grass catcher assembly mounted in place, you and others are exposed to blade contact and thrown debris. Contact with rotating mower blade(s) and thrown debris will cause injury or death.

- Never remove the grass deflector from the mower because the grass deflector routes material down toward the turf. If the grass deflector is ever damaged, replace it immediately.
- Never put your hands or feet under the mower.
- Never try to clear discharge area or mower blades unless you release the bail and the power take off (PTO) is off. Rotate the ignition key to Off. Also remove the key and pull the wire(s) off the spark plug(s).

Adjusting the Height-of-Cut

The height-of-cut can be adjusted from 1 to 5 inches (25 to 127 mm) in 1/4 inch (6 mm) increments.

1. Move the height-of-cut lever to the transport position (all the way up).
2. Select a hole in the height-of-cut bracket corresponding to the height-of-cut desired and, insert the pin (Figure 28).
3. Lower the height-of-cut lever to the pin (Figure 28).

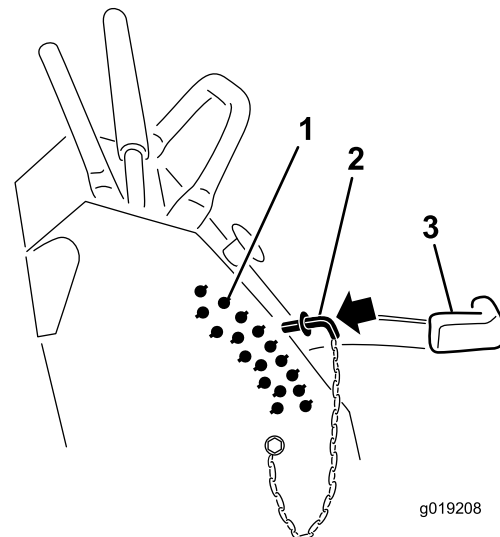

Figure 28

- | | |
|------------------------|------------------------|
| 1. Height-of-cut holes | 3. Height-of-cut lever |
| 2. Height-of-cut pin | |

Adjusting the Anti-Scalp Rollers (60 inch Mower Decks Only)

Whenever you change the height-of-cut, it is recommended to adjust the height of the anti-scalp rollers.

1. Disengage the blade control switch (PTO), move the motion control levers to the neutral locked position and set the parking brake.
2. Stop the engine, remove the key, and wait for all moving parts to stop before leaving the operating position.
3. Remove the nut and bolt position the anti-scalp rollers and install the nut and bolt. Ensure the spacers and bushings are installed as shown.

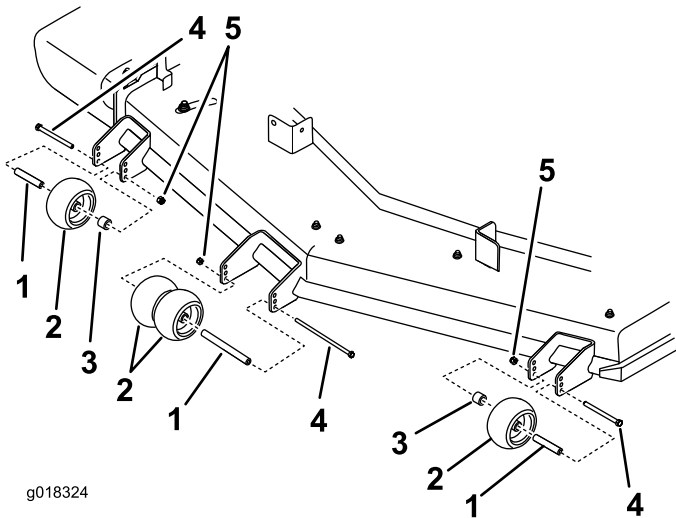

Figure 29

- | | |
|----------------------|---------|
| 1. Bushing | 4. Bolt |
| 2. Anti-scalp roller | 5. Nut |
| 3. Spacer | |

Adjusting the Flow Baffle

The mower discharge flow can be adjusted for different types of mowing conditions. Position the cam lock and baffle to give the best quality of cut.

1. Disengage the PTO, move the motion control levers to the neutral locked position and set the parking brake.
2. Stop the engine, remove the key, and wait for all moving parts to stop before leaving the operating position.
3. To adjust the baffle, loosen the nut (Figure 30).
4. Adjust the baffle and nut in the slot to the desired discharge flow and tighten the nut.

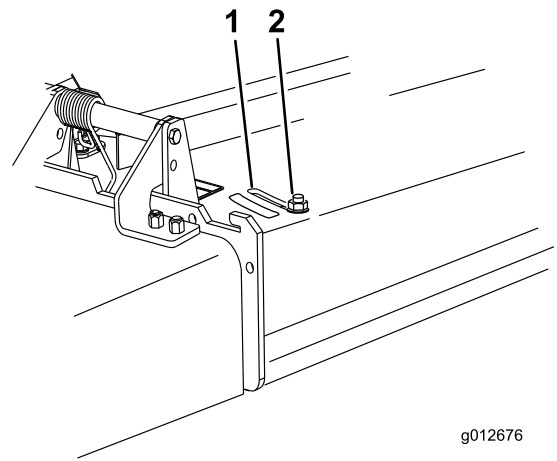

g012676

Figure 30

- | | |
|---------|--------|
| 1. Slot | 2. Nut |
|---------|--------|

Positioning the Flow Baffle

The following figures are only recommendations for use. Adjustments will vary by grass type, moisture content, and height of grass.

Note: If the engine power draws down and the mower ground speed is the same, open up the baffle.

Position A

This is the full rear position (see Figure 31). The suggested use for this position is as follows.

- Use for short, light grass mowing conditions.
- Use in dry conditions.
- For smaller grass clippings.
- Propels grass clippings farther away from the mower.

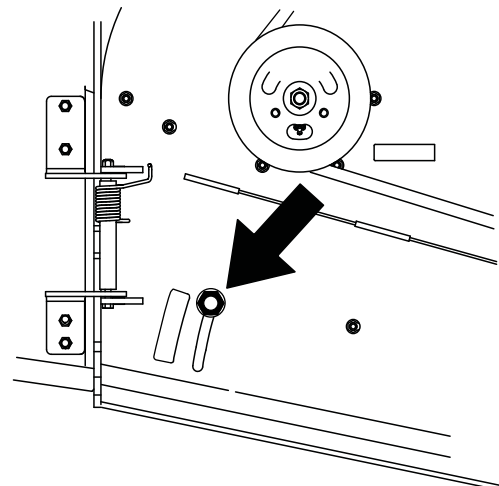

G012677

Figure 31

Position B

Use this position when bagging (Figure 32).

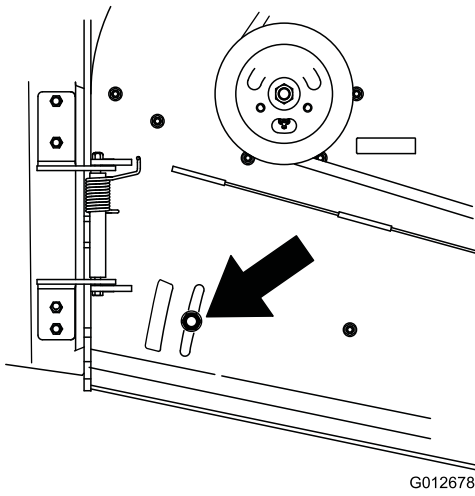

Figure 32

⚠ WARNING

Excessive weight changes can effect handling and operation of the machine. This could cause serious injury to you or bystanders.

Make weight changes is small increments only.

Evaluate the mower after each weight change to ensure the machine can be operated safely.

Position C

This is the full open position. The suggested use for this position is as follows (Figure 33).

- Use in tall, dense grass mowing conditions.
- Use in wet conditions.
- Lowers the engine power consumption.
- Allows increased ground speed in heavy conditions.

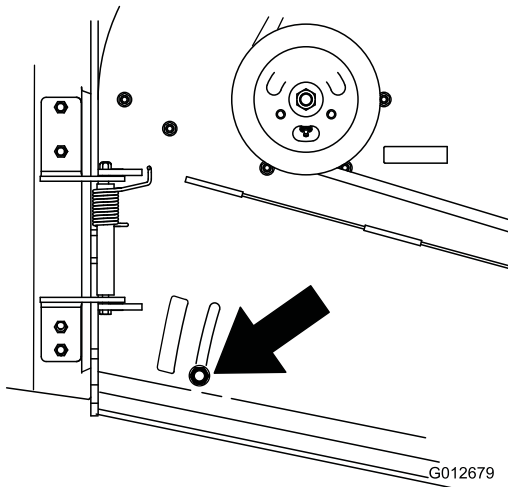

Figure 33

Using the Mid-Size Weight

- Weights are installed to improve handling, balance and improve performance. Weights can be added or removed to create optimized performance under different mowing conditions and for operator preference.
- It is recommended that weights be added or removed one at a time until the desired handing and balance is achieved.

Note: Contact an Authorized Service Dealer to order a Weight Kit.

Maintenance

Note: Determine the left and right sides of the machine from the normal operating position.

Recommended Maintenance Schedule(s)

Maintenance Service Interval	Maintenance Procedure
After the first 8 hours	<ul style="list-style-type: none"> • Change the engine oil. • Check the hydraulic fluid level. • Change the hydraulic filter.
Before each use or daily	<ul style="list-style-type: none"> • Check the safety interlock system. • Check the engine oil level. • Clean the air intake screen. • Clean debris from the hydraulic oil cooler (if equipped). • Check the brakes. • Inspect the blades. • Clean the mower deck.
Every 25 hours	<ul style="list-style-type: none"> • Clean foam air cleaner element.
Every 50 hours	<ul style="list-style-type: none"> • Grease the lift linkage (more often in dirty or dusty conditions). • Grease the mower deck spindles (more often in dirty or dusty conditions). • Check the paper air cleaner element. • Check spark arrester (if equipped). • Check the tire pressure. • Check the hydraulic fluid level.
Every 100 hours	<ul style="list-style-type: none"> • Change the engine oil. (more often in dirty or dusty conditions) • Check, clean and regap the spark plug. • Check the battery. • Check the electric clutch. • Check and clean engine cooling fins and shrouds. • Service the hydraulic oil cooler (in dirty conditions) (if equipped). • Check the mower deck belt. • Check the pump drive belt. • Check the hydraulic hoses.
Every 200 hours	<ul style="list-style-type: none"> • Replace the paper air cleaner element. • Change the engine oil filter.
Every 250 hours	<ul style="list-style-type: none"> • Change the hydraulic filter and hydraulic oil when using Mobil® 1 oil.
Every 500 hours	<ul style="list-style-type: none"> • Adjust the caster pivot bearing. • Change the hydraulic filter and hydraulic oil when using Toro® HYPR-OIL™ 500 hydraulic oil.
Every 800 hours	<ul style="list-style-type: none"> • Grease the front wheel bearings (more often in dirty or dusty conditions). • Grease the front caster pivots (more often in dirty or dusty conditions). • Replace the fuel filter.
Before storage	<ul style="list-style-type: none"> • Paint chipped surfaces. • Perform all maintenance procedures listed above before storage.
Yearly	<ul style="list-style-type: none"> • Grease the front caster pivots (more often in dirty or dusty conditions). • Lubricate the caster wheel hubs

Important: Refer to your *Engine Operator's Manual* for additional maintenance procedures.

⚠ CAUTION

If you leave the key in the ignition switch, someone could accidentally start the engine and seriously injure you or other bystanders.

Remove the key from the ignition and disconnect the spark plug wires from the spark plugs before you do any maintenance. Set the wires aside so that they do not accidentally contact the spark plugs.

Premaintenance Procedures

Raising the Mower for Access

The front of the mower can be raised and supported on its back for access under the machine for maintenance.

1. Raise the platform. Refer to Operating the Platform in Operation.
2. Remove the battery.

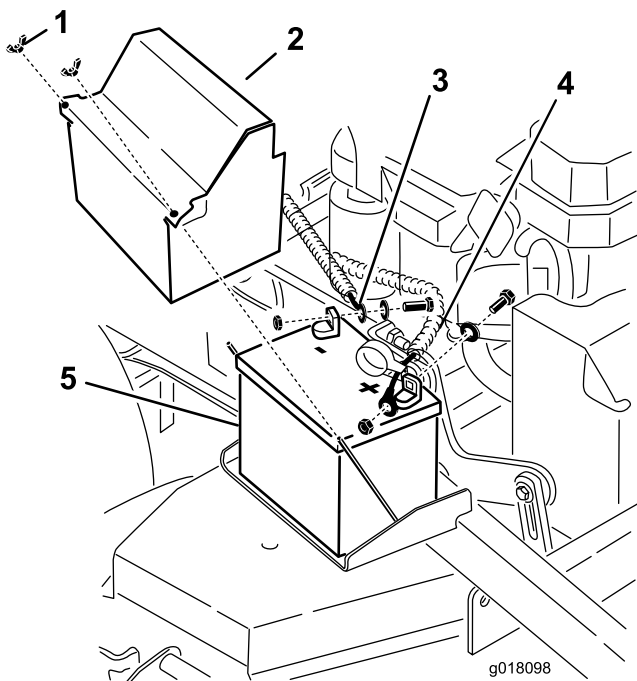

Figure 34

1. Wing nut
2. Battery cover
3. Negative battery cable
4. Positive battery cable
5. Battery

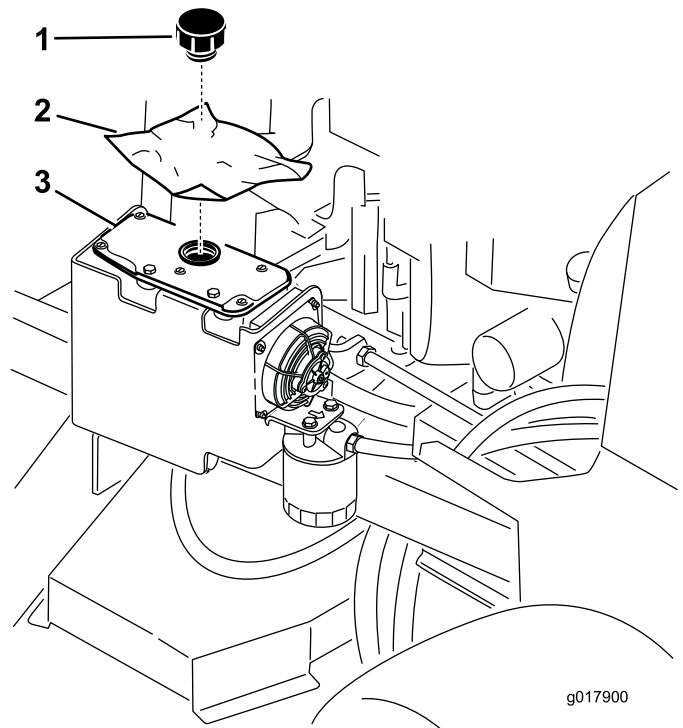

Figure 35

1. Cap
2. Piece of plastic
3. Hydraulic tank

5. With two people, raise the front of the mower so it rests on the drive tires and the platform in the up position.
6. Perform any maintenance on the machine.
7. With two people, lower the front of the mower to the ground.
8. Remove the plastic under the hydraulic tank cap.
9. Install the battery for the machine.

3. Drain the fuel from the fuel tank. Refer to Draining the Fuel Tank in Maintenance.
4. Remove the cap of the hydraulic tank and place a piece of plastic over the opening and install the hydraulic cap. This will seal the hydraulic tank and prevent it from leaking out.

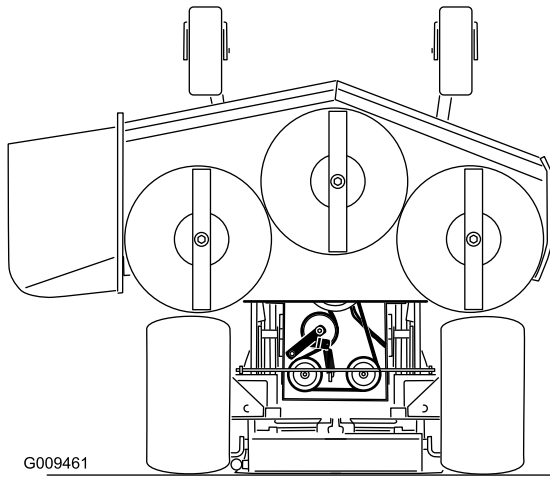
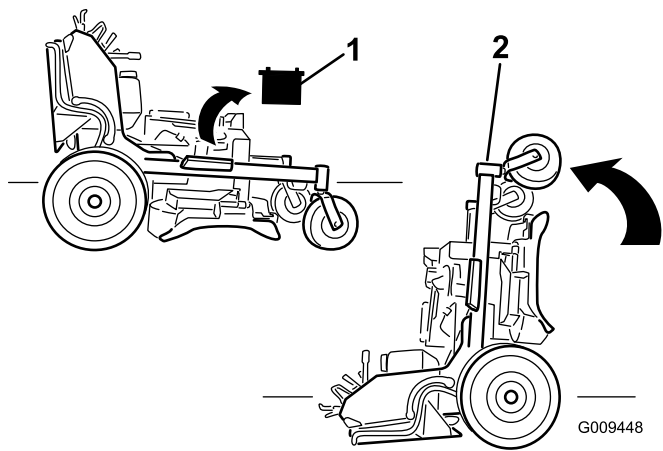

Figure 36

1. Remove battery
2. With two people, lift the front end of the mower (ensure the platform is up)

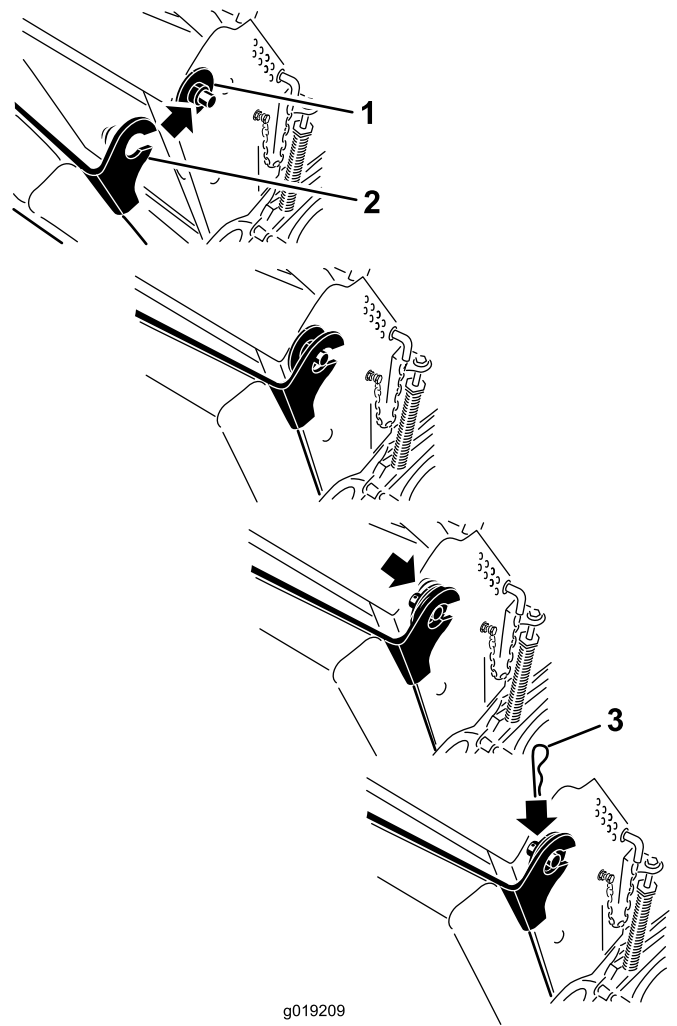

Figure 37

1. Plastic bushing with large washer
2. Cushion bracket with key hole
3. Hairpin cotter pin

Release the Cushion for Rear Access

The cushion can be released for rear access to the machine for maintenance or adjustment.

1. Lower the platform.
2. Remove the hairpin cotter pins on each side of the cushion.
3. Slide the large washers with plastic bushings to the inside.
4. Remove the cushion and lower it to the platform.
5. Perform any maintenance or adjustment on the machine.
6. Raise the cushion and slide it onto the pins on both sides of the machine (Figure 37).
7. Slide the large washers plastic bushings into the cushion bracket and secure them with a hairpin cotter pin (Figure 37).

Lubrication

Grease with No. 2 general purpose lithium base or molybdenum base grease.

How to Grease

1. Disengage the PTO and set the parking brake.
2. Stop the engine, remove the key, and wait for all moving parts to stop before leaving the operating position.
3. Clean the grease fittings with a rag. Make sure to scrape any paint off the front of the fitting(s).
4. Connect a grease gun to the fitting. Pump grease into the fittings until grease begins to ooze out of the bearings.
5. Wipe up any excess grease.

Lubricating the Machine

Service Interval: Every 50 hours—Grease the lift linkage (more often in dirty or dusty conditions).

Every 50 hours—Grease the mower deck spindles (more often in dirty or dusty conditions).

Every 800 hours/Yearly (whichever comes first)—Grease the front wheel bearings (more often in dirty or dusty conditions).

Every 800 hours/Yearly (whichever comes first)—Grease the front caster pivots (more often in dirty or dusty conditions).

Use the following graphics for locating the grease points.

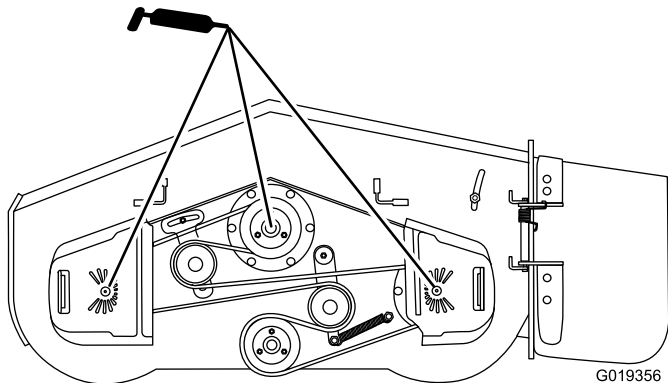

Figure 38

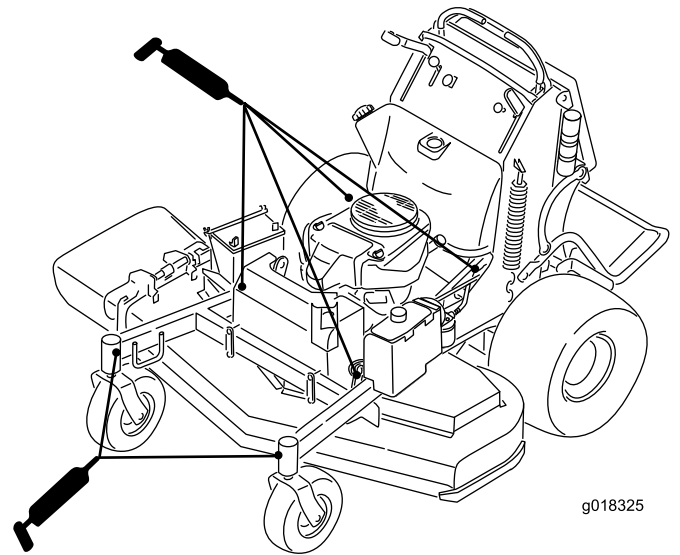

Figure 39

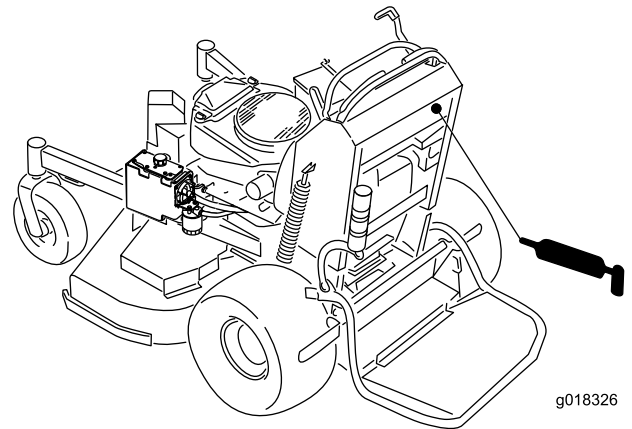

Figure 40

Greasing the Front Caster Pivots

Service Interval: Yearly

Lubricate the front caster pivots once a year.

1. Remove the dust cap and adjust the caster pivots. Keep the dust cap off until greasing is done. Refer to Adjusting the Caster Pivot Bearing in Maintenance Section.
2. Remove the hex plug. Thread a grease zerk into the hole.
3. Pump grease into the zerk until it oozes out around the top bearing.
4. Remove the grease zerk in the hole. Install the hex plug and cap.

Lubricate Caster Wheel Hubs

Service Interval: Yearly

1. Stop the engine, wait for all moving parts to stop, and remove the key. Engage the parking brake.

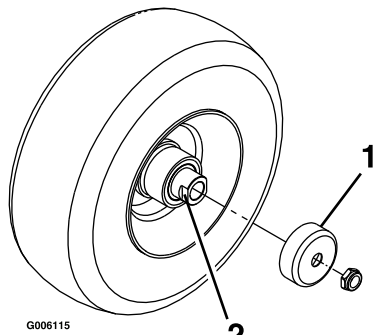

Figure 41

1. Seal guard
2. Spacer nut with wrench flats

tire should not spin freely (more than 1 or 2 revolutions) or have any side play. If the wheel spins freely, adjust torque on spacer nut until there is a slight amount of drag. Reapply thread locking adhesive.

2. Remove the caster wheel from the caster forks.
 3. Remove the seal guards from the wheel hub.
 4. Remove one of the spacer nuts from the axle assembly in the caster wheel. Note that thread locking adhesive has been applied to lock the spacer nuts to the axle. Remove the axle (with the other spacer nut still assembled to it) from the wheel assembly.
 5. Pry out seals, and inspect bearings for wear or damage and replace if necessary.
 6. Pack the bearings with a general-purpose grease.
 7. Insert one bearing, one new seal into the wheel.
- Note:** The seals must be replaced.
8. If the axle assembly has had both spacer nuts removed (or broken loose), apply a thread locking adhesive to one spacer nut and thread onto the axle with the wrench flats facing outward. Do Not thread spacer nut all of the way onto the end of the axle. Leave approximately 1/8 inch (3 mm) from the outer surface of the spacer nut to the end of the axle inside the nut.
 9. Insert the assembled nut and axle into the wheel on the side of the wheel with the new seal and bearing.
 10. With the open end of the wheel facing up, fill the area inside the wheel around the axle full of general-purpose grease.
 11. Insert the second bearing and new seal into the wheel.
 12. Apply a thread locking adhesive to the 2nd spacer nut and thread onto the axle with the wrench flats facing outward.
 13. Torque the nut to 75-80 in-lb (8-9 N-m), loosen, then re-torque to 20-25 in-lb (2-3 N-m). Make sure axle does not extend beyond either nut.
 14. Reinstall the seal guards over the wheel hub and insert wheel into caster fork. Reinstall caster bolt and tighten nut fully.

Important: To prevent seal and bearing damage, check the bearing adjustment often. Spin the caster tire. The

Engine Maintenance

Servicing the Air Cleaner

Service Interval/Specification

Inspect the foam and paper elements and replace them if they are damaged or excessively dirty.

Note: Service the air cleaner more frequently (every few operating hours) if the operating conditions are extremely dusty or sandy.

Important: Do not oil the foam or paper element.

Removing the Foam and Paper Elements

1. Disengage the PTO and set the parking brake.
2. Stop the engine, remove the key, and wait for all moving parts to stop before leaving the operating position.
3. Clean around the air cleaner to prevent dirt from getting into the engine and causing damage (Figure 42).
4. Unscrew the cover knobs and remove the air cleaner cover (Figure 42).
5. Unscrew the hose clamp and remove the air cleaner assembly (Figure 42).
6. Carefully pull the foam element off the paper element (Figure 42).

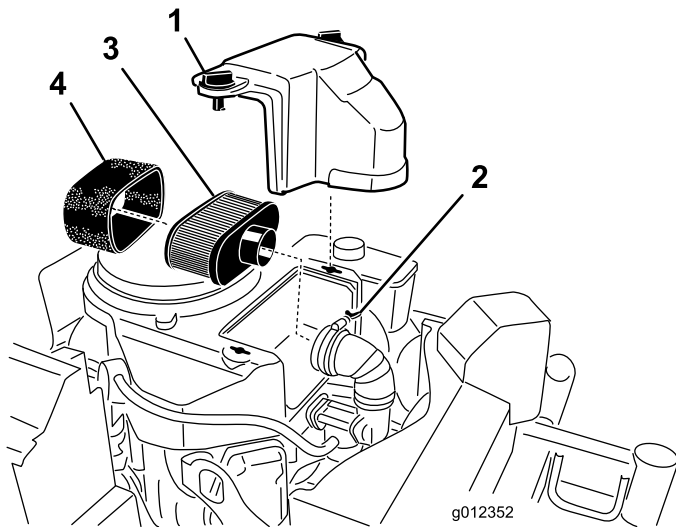

Figure 42

- | | |
|---------------|------------------|
| 1. Cover | 3. Paper element |
| 2. Hose clamp | 4. Foam element |

Cleaning the Foam Air Cleaner Element

Service Interval: Every 25 hours

1. Wash the foam element in liquid soap and warm water. When the element is clean, rinse it thoroughly.

2. Dry the element by squeezing it in a clean cloth.

Important: Replace the foam element if it is torn or worn.

Servicing the Paper Air Cleaner Element

Service Interval: Every 50 hours—Check the paper air cleaner element.

Every 200 hours—Replace the paper air cleaner element.

1. Do not clean the paper filter, replace it (Figure 42).
2. Inspect the element for tears, an oily film, or damage to the rubber seal.
3. Replace the paper element if it is damaged.

Installing the Foam and Paper Elements

Important: To prevent engine damage, always operate the engine with the complete foam and paper air cleaner assembly installed.

1. Carefully slide the foam element onto the paper air cleaner element (Figure 42).
2. Place the air cleaner assembly onto the air cleaner base or hose and secure it (Figure 42).
3. Place the air cleaner cover into position and tighten the cover knob (Figure 42).

Servicing the Engine Oil

Service Interval: Before each use or daily—Check the engine oil level.

After the first 8 hours—Change the engine oil.

Every 100 hours—Change the engine oil. (more often in dirty or dusty conditions)

Every 200 hours—Change the engine oil filter.

Note: Change the oil more frequently when the operating conditions are extremely dusty or sandy.

Note: There are different oil capacities for the different models listed in this manual. Ensure the correct amount of oil is used.

Important: Remember to add 80% of the oil and then gradually fill it to the full mark on the dipstick.

Oil Type: Detergent oil (API service SF, SG, SH, SJ or SL)

Engine Oil Capacity: 71 ounces (2.1 liter) with the filter removed; 61 ounces (1.8 liter) without the filter removed

Viscosity: Refer to the table below

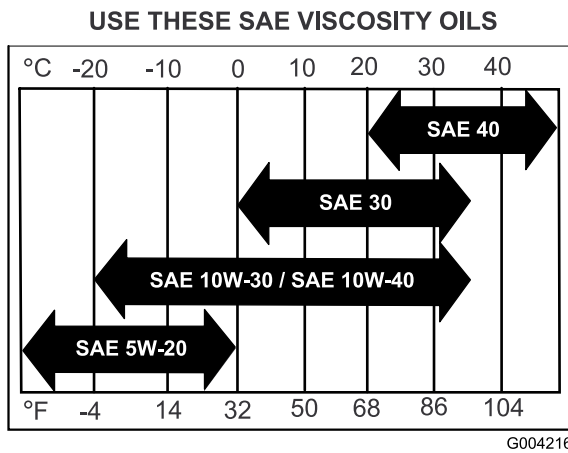

Figure 43

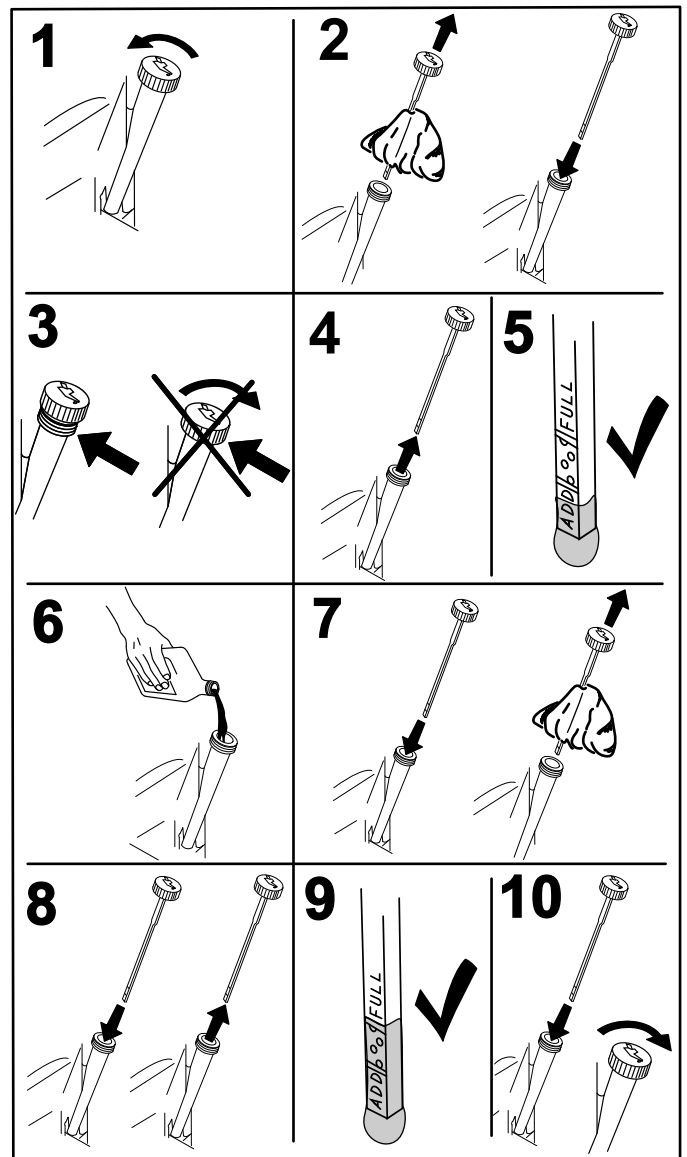
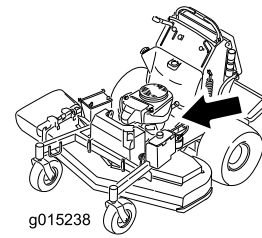

Figure 44

G008792

Checking the Engine Oil Level

Note: Check the oil when the engine is cold.

⚠ WARNING

Contact with hot surfaces may cause personal injury.

Keep hands, feet, face, clothing and other body parts away the muffler and other hot surfaces.

Important: Do not overfill the crankcase with oil because damage to the engine may result. Do not run engine with oil below the low mark because the engine may be damaged.

1. Disengage the PTO, move the motion control levers to the neutral locked position and set the parking brake.
2. Stop the engine, remove the key, and wait for all moving parts to stop before leaving the operating position (Figure 44).

Changing the Engine Oil

Note: Dispose of the used oil at a recycling center.

1. Park the machine so that the drain side is slightly lower than the opposite side to assure the oil drains completely.
2. Disengage the PTO, move the motion control levers to the neutral locked position and set the parking brake.
3. Stop the engine, remove the key, and wait for all moving parts to stop before leaving the operating position.

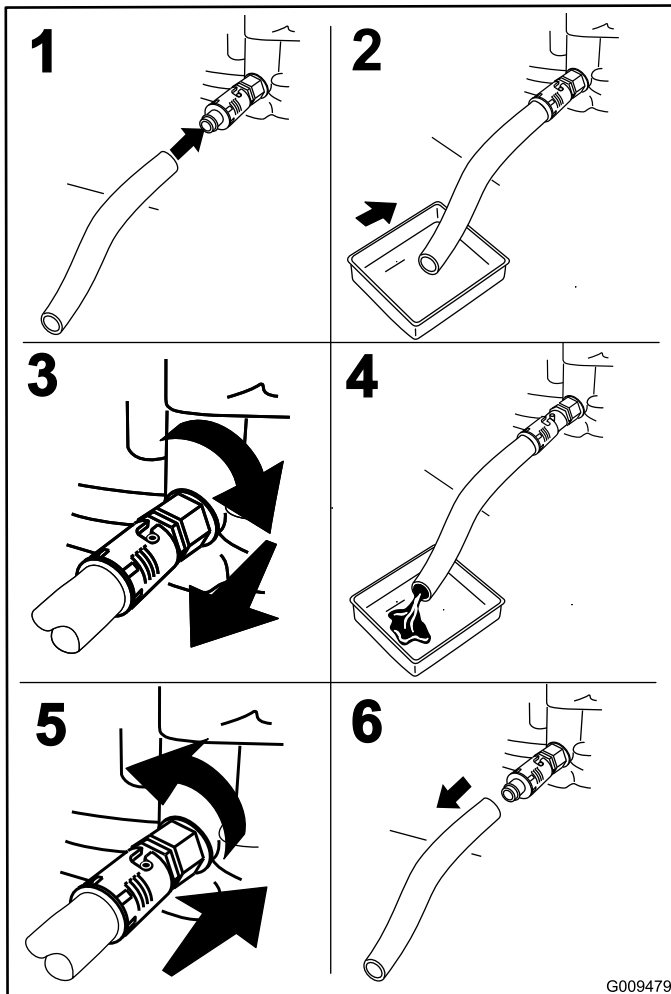
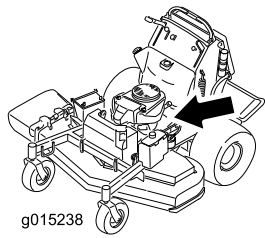

Figure 45

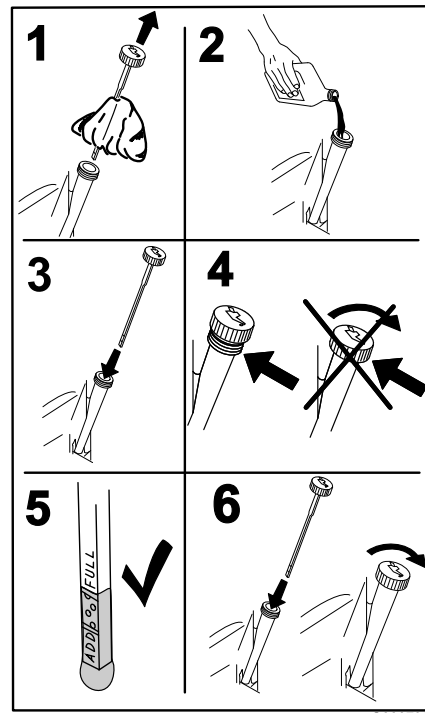

Figure 46

4. Slowly pour approximately 80% of the specified oil into the filler tube and slowly add the additional oil to bring it to the **Full** mark (Figure 46).

5. Start the engine and drive to a flat area. Check the engine oil level.

Changing the Engine Oil Filter

Note: Change the engine oil filter more frequently when operating conditions are extremely dusty or sandy.

1. Drain the oil from the engine; refer to Changing the Engine Oil.
2. Place a rag under the oil filter to soak up any spilled oil.

Important: Spilled oil may drain under the engine and onto the clutch. Oil spilled on the clutch may damage the clutch, cause the blades to stop slowly when the clutch is switched off and cause the clutch to slip when the clutch is switched on. **Wipe up any spilled oil.**

3. Change the engine oil filter (Figure 47).

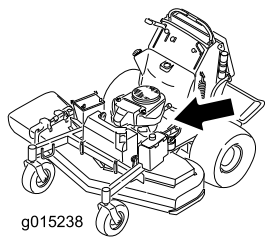

Removing the Spark Plug

1. Disengage the PTO, move the motion control levers to the neutral locked position and set the parking brake.
2. Stop the engine, remove the key, and wait for all moving parts to stop before leaving the operating position.

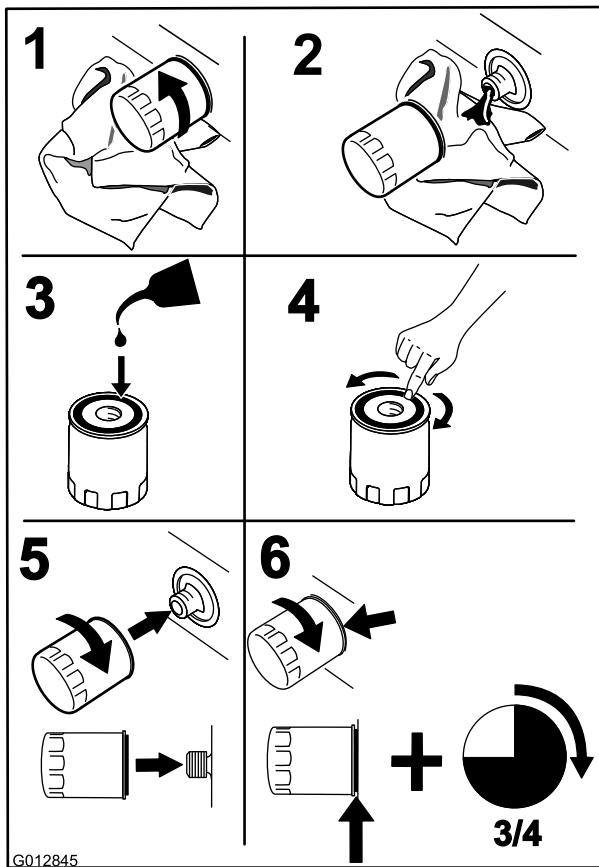
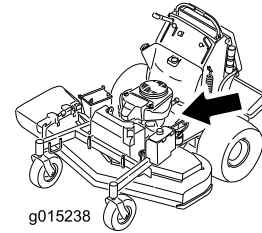

Figure 47

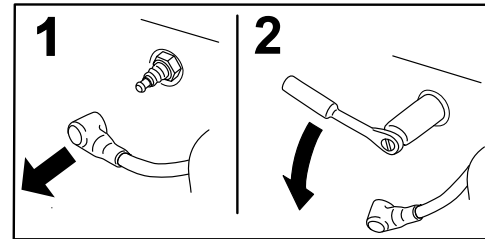

Figure 48

Checking the Spark Plug

Important: Never clean the spark plug(s). Always replace the spark plug(s) when it has: a black coating, worn electrodes, an oily film, or cracks.

If you see light brown or gray on the insulator, the engine is operating properly. A black coating on the insulator usually means the air cleaner is dirty.

Set the gap to 0.030 inches (0.75 mm).

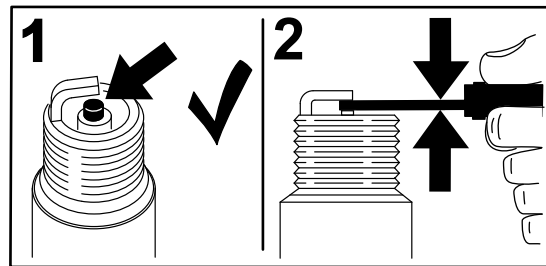

Figure 49

Note: Ensure the oil filter gasket touches the engine and then an extra 3/4 turn is completed.

4. Fill the crankcase with the proper type of new oil; refer to Changing the Oil.

Servicing the Spark Plug

Service Interval: Every 100 hours

Make sure the air gap between the center and side electrodes is correct before installing the spark plug. Use a spark plug wrench for removing and installing the spark plug(s) and a gapping tool/feeler gauge to check and adjust the air gap. Install a new spark plug(s) if necessary.

Type for all Engines: NGK® BPR4ES or equivalent

Air Gap: 0.030 inch (0.75 mm)

Installing the Spark Plug

Tighten the spark plug(s) to 16 ft.-lb (22 N-m).

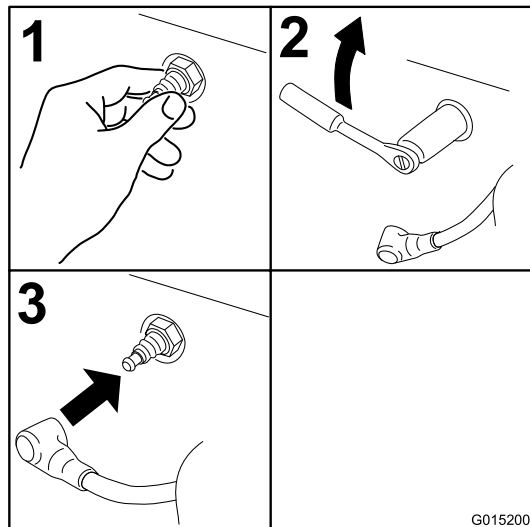

Figure 50

Check Spark Arrester (if equipped)

Service Interval: Every 50 hours

⚠ WARNING

Hot exhaust system components may ignite gasoline vapors even after the engine is stopped. Hot particles exhausted during engine operation may ignite flammable materials. Fire may result in personal injury or property damage.

Do Not refuel or run engine unless spark arrester is installed.

1. Stop engine, wait for all moving parts to stop, and remove key. Engage parking brake.
2. Wait for muffler to cool.
3. If any breaks in the screen or welds are observed, replace the arrester.
4. If plugging of the screen is observed, remove the arrester and shake loose particles out of the arrester and clean screen with a wire brush (soak in solvent if necessary). Reinstall arrester on exhaust outlet.

Fuel System Maintenance

Draining the Fuel Tank

Note: There is no other recommended way to drain fuel from the tank, other than using a syphon pump. A syphon pump can be purchased at a hardware store.

⚠ DANGER

In certain conditions, gasoline is extremely flammable and highly explosive. A fire or explosion from gasoline can burn you and others and can damage property.

- Drain gasoline from the fuel tank when the engine is cold. Do this outdoors in an open area. Wipe up any gasoline that spills.
- Never smoke when draining gasoline, and stay away from an open flame or where a spark may ignite the gasoline fumes.

1. Park the machine on a level surface. Disengage the power take off (PTO), set the parking brake, turn the ignition key to **Off** and remove the key.
2. Clean around the fuel cap to prevent debris from getting into the fuel tank (Figure 52).
3. Remove the fuel cap.
4. Insert a syphon pump into the fuel tank.
5. Using the syphon pump, drain the fuel into a clean gas can (Figure 51).
6. Wipe up any spilled fuel.

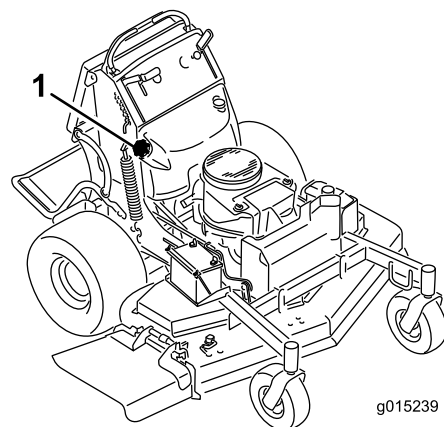

Figure 51

1. Fuel cap

Servicing the Fuel Filter

Replacing the Fuel Filter

Service Interval: Every 800 hours/Yearly (whichever comes first)

Never install a dirty filter if it is removed from the fuel line.

Note: Note how the fuel filter is installed in order to install the new filter correctly.

Note: Wipe up any spilled fuel.

1. Disengage the PTO and set the parking brake.
2. Stop the engine, remove the key, and wait for all moving parts to stop before leaving the operating position.
3. Close fuel shut-off valve (behind the operator cushion).
4. Squeeze the ends of the hose clamps together and slide them away from the filter (Figure 52).

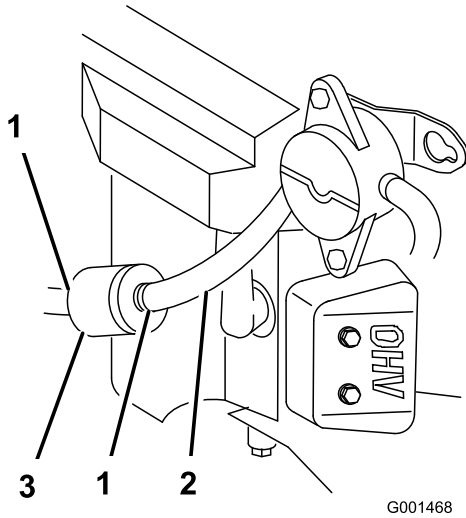

Figure 52

1. Hose clamp
2. Fuel line
3. Filter

5. Remove the filter from the fuel lines.
6. Install a new filter and move the hose clamps close to the filter.
7. Open the fuel shut-off valve.
8. Check for fuel leaks and repair if needed.
9. Wipe up any spilled fuel.

Electrical System Maintenance

Servicing the Battery

Service Interval: Every 100 hours

Always keep the battery clean and fully charged. Use a paper towel to clean the battery case. If the battery terminals are corroded, clean them with a solution of four parts water and one part baking soda. Apply a light coating of grease to the battery terminals to prevent corrosion.

Voltage: 12 V

WARNING

CALIFORNIA Proposition 65 Warning

Battery posts, terminals, and related accessories contain lead and lead compounds, chemicals known to the State of California to cause cancer and reproductive harm.
Wash hands after handling.

▲ DANGER

Battery electrolyte contains sulfuric acid which is a deadly poison and causes severe burns.

Do not drink electrolyte and avoid contact with skin, eyes or clothing. Wear safety glasses to shield your eyes and rubber gloves to protect your hands.

Removing the Battery

▲ WARNING

Battery terminals or metal tools could short against metal machine components causing sparks. Sparks can cause the battery gasses to explode, resulting in personal injury.

- When removing or installing the battery, do not allow the battery terminals to touch any metal parts of the machine.
- Do not allow metal tools to short between the battery terminals and metal parts of the machine.

▲ WARNING

Incorrect battery cable routing could damage the machine and cables causing sparks. Sparks can cause the battery gasses to explode, resulting in personal injury.

- Always Disconnect the negative (black) battery cable before disconnecting the positive (red) cable.
 - Always Reconnect the positive (red) battery cable before reconnecting the negative (black) cable.
1. Disengage the PTO and set the parking brake.
 2. Stop the engine, remove the key, and wait for all moving parts to stop before leaving the operating position.
 3. Lift the black rubber cover on the negative cable. Disconnect the negative battery cable from the negative (-) battery terminal (Figure 53).
 4. Slide the red terminal boot off the positive (red) battery terminal. Then remove the positive (red) battery cable (Figure 53).
 5. Remove the battery hold down plate (Figure 53) and remove the battery.

Installing the Battery

1. Place the battery onto the machine (Figure 53).
2. Secure the battery with the hold down plate, j-bolts, and locknuts.
3. First, install the positive (red) battery cable to positive (+) battery terminal with a nut, washer and bolt (Figure 53). Slide the rubber cover over the post.
4. Then install the negative battery cable and ground wire to the negative (-) battery terminal with a nut, washer and bolt (Figure 53). Slide the rubber cover over the post.

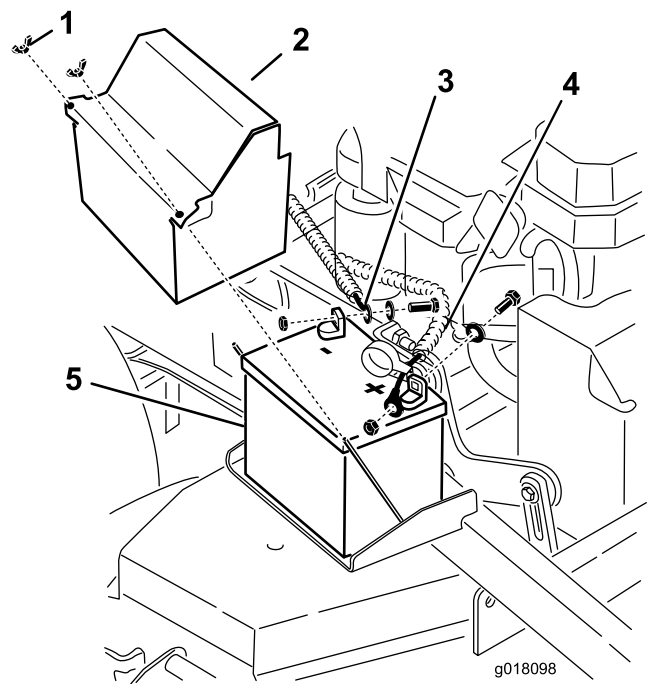

Figure 53

- | | |
|---------------------------|---------------------------|
| 1. Wing nut | 4. Positive battery cable |
| 2. Battery cover | 5. Battery |
| 3. Negative battery cable | |

Charging the Battery

▲ WARNING

Charging the battery produces gasses that can explode.

Never smoke near the battery and keep sparks and flames away from battery.

Important: Always keep the battery fully charged (1.265 specific gravity). This is especially important to prevent battery damage when the temperature is below 32°F (0°C).

1. Remove the battery from the chassis; refer to Removing the Battery.
2. Check the electrolyte level; refer to Checking the Electrolyte Level.
3. Make sure the filler caps are installed in battery. Charge battery for 1 hour at 25 to 30 amps or 6 hours at 4 to 6 amps.
4. When the battery is fully charged, unplug the charger from the electrical outlet, then disconnect the charger leads from the battery posts (Figure 54).
5. Install the battery onto the machine and connect the battery cables, refer to Installing the Battery.

Note: Do not run the machine with the battery disconnected, electrical damage may occur.

Drive System Maintenance

Adjusting the Tracking

Note: Determine the left and right sides of the machine from the normal operating position.

1. Push both control levers forward the same distance.
2. Check if the machine pulls to one side. If it does, stop the machine and set the parking brake.
3. Release the cushion from the rear of the machine.
4. Lift and remove the cable lock securing the cable adjusting nuts (Figure 57).
5. Rotate the right cable adjustment to position the right motion control in the center of the control panel neutral lock slot (Figure 57).

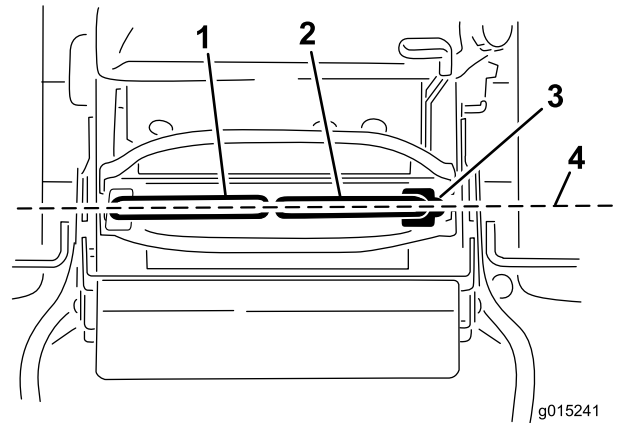

Figure 56

1. Left motion control lever
2. Right motion control lever
3. Neutral locked position
4. Align the control levers front to back

6. Rotate the left cable adjustment to match the left wheel speed to the previously set right wheel speed. Adjust in quarter-turn increments until the machine tracks straight.

Note: Only adjust the left cable to match the left wheel speed to the right wheel speed. Do not adjust the right wheel speed as this will position the right motion control lever out of the center for the control panel neutral lock slot.

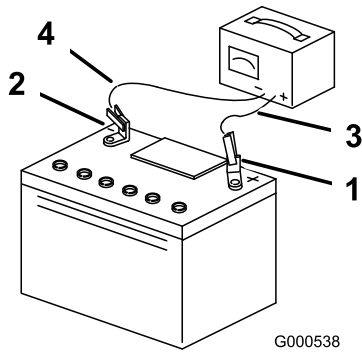

Figure 54

1. Positive Battery Post
2. Negative Battery Post
3. Red (+) Charger Lead
4. Black (-) Charger Lead

Servicing the Fuses

The electrical system is protected by fuses. It requires no maintenance. If a fuse blows, check the component or circuit for a malfunction or short.

1. Release the cushion from the rear of the machine.
2. Pull out on the fuse to remove or replace it (Figure 55).
3. Install the cushion to the rear of the machine.

Note: Ensure the correct size fuse is installed (Figure 55).

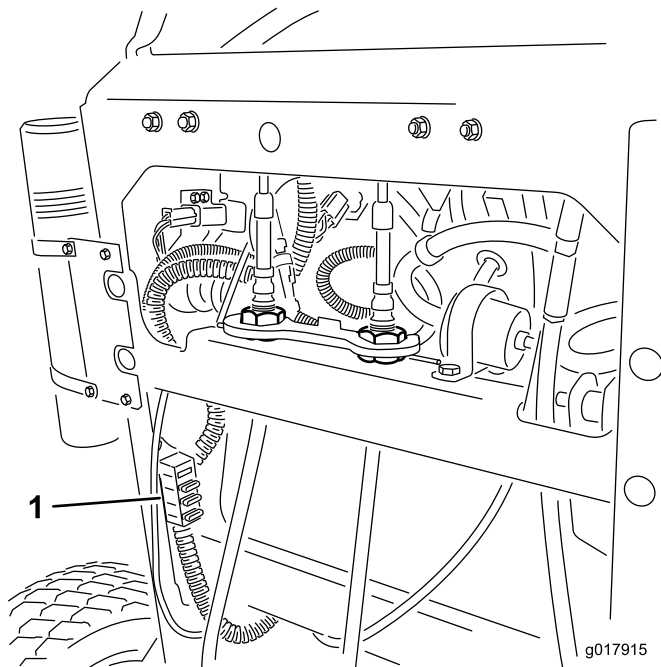

Figure 55

1. Fuses

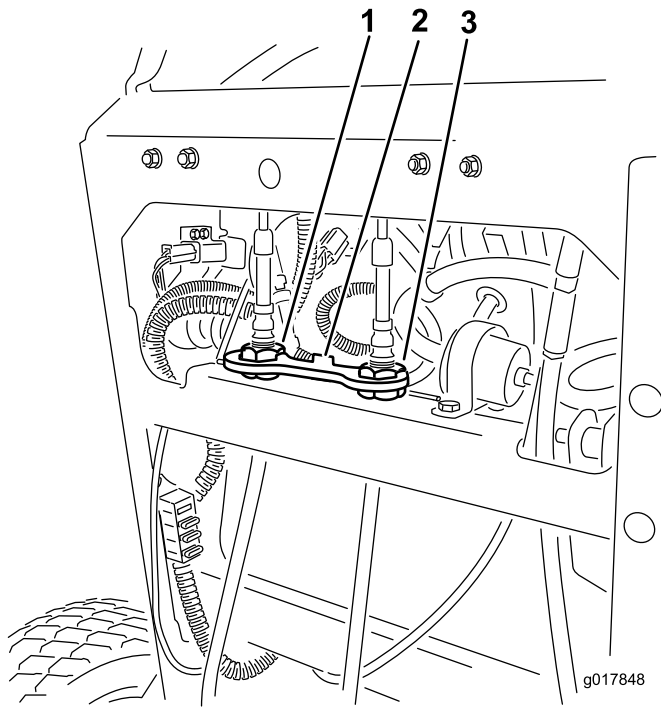

Figure 57

- | | |
|--------------------------|---------------------------|
| 1. Left cable adjustment | 3. Right cable adjustment |
| 2. Cable lock | |

7. Check for proper tracking.

Note: If the machine will not start after adjusting the tracking, make sure proximity switch target aligns with bolt attached to motion control lever. Refer to Adjusting the Proximity Switch (page 40).

8. Repeat the cable adjustment until the tracking is correct.
9. Check that the machine does not creep from neutral with the park brakes disengaged.

Important: Do Not rotate the linkage too far, as this may cause the machine to creep in neutral.

10. Install the cable lock onto the cable adjusting nuts to secure the adjustment (Figure 57).

Adjusting the Proximity Switch

Use this procedure if the machine will not start after adjusting the tracking.

1. Check and ensure the bolt attached to the motion control lever aligns with the proximity switch target (Figure 58).
2. If needed, loosen the bolts and adjust the proximity switch until the target aligns with bolt attached to the motion control lever (Figure 58).
3. Check the distance of the bolt to the proximity switch. It needs to be between 0.050 and 0.090 inches (1.27 to 2.29 mm) (Figure 58).

4. If adjustment is needed, loosen the jam nut and adjust the bolt to the correct distance. Tighten the jam nut after adjusting the bolt (Figure 58).
5. Test the safety interlock system before operation.

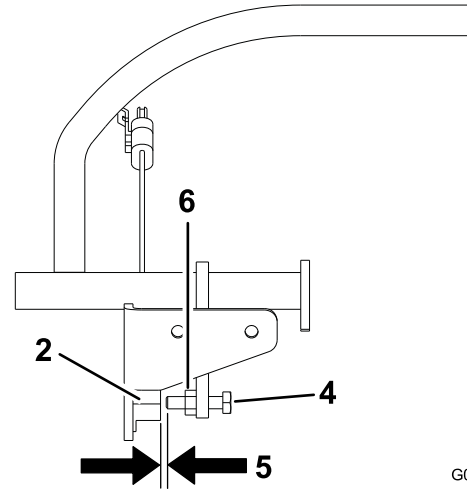
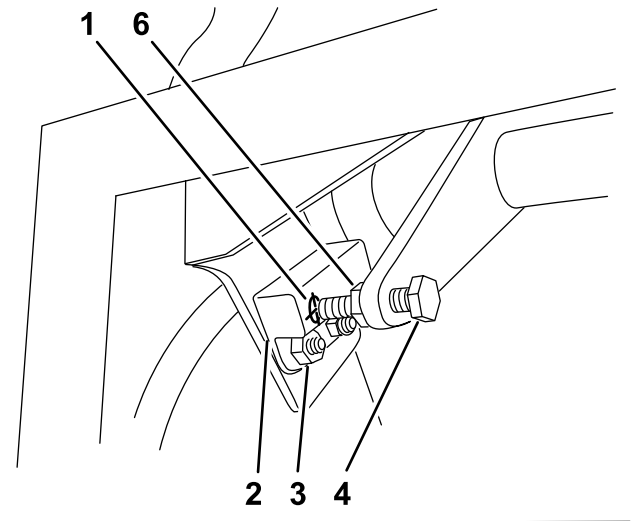

Figure 58

- | | |
|----------------------------|--|
| 1. Proximity switch target | 4. Bolt attached to the motion control lever |
| 2. Proximity switch | 5. Distance between 0.050 and 0.090 inches (1.27 to 2.29 mm) is needed |
| 3. Bolts and nuts | 6. Jam nut |

Checking the Tire Pressure

Service Interval: Every 50 hours/Monthly (whichever comes first)

Maintain the air pressure in the rear tires at 12-14 psi (83-97 kPa). Uneven tire pressure can cause an uneven cut.

Note: The front tires are semi-pneumatic tires and do not require air pressure maintenance.

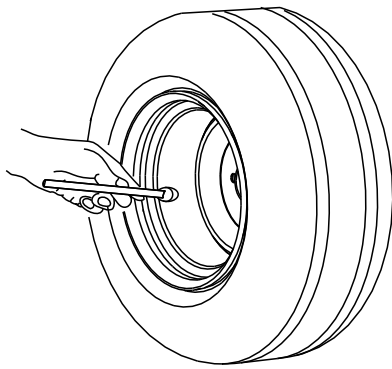

Figure 59

Adjusting the Caster Pivot Bearing

Service Interval: Every 500 hours/Yearly (whichever comes first)

1. Disengage the blade control switch (PTO), move the motion control levers to the neutral locked position and set the parking brake.
2. Stop the engine, remove the key, and wait for all moving parts to stop before leaving the operating position.
3. Remove the dust cap from caster and tighten lock nut (Figure 60).
4. Tighten the locknut until the spring washers are flat and then back off a 1/4 turn to properly set the pre-load on the bearings (Figure 60).

Important: Make sure spring washers are installed correctly as shown in Figure 60.

5. Install the dust cap (Figure 60).

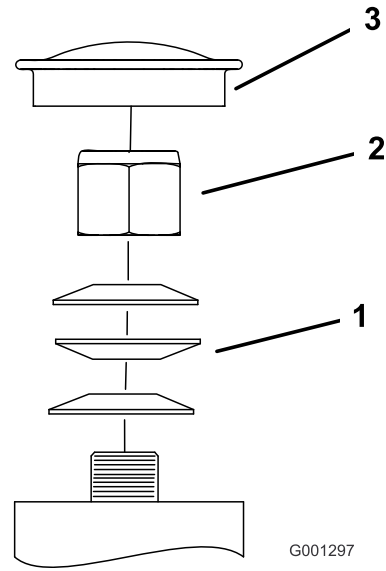

Figure 60

- | | |
|-------------------|-------------|
| 1. Spring Washers | 3. Dust Cap |
| 2. Lock Nut | |

Servicing the Caster Wheel and Bearings

The caster wheels rotate on a roller bearing supported by a spanner bushing. If the bearing is kept well lubricated, wear will be minimal. Failure to keep the bearing well lubricated will cause rapid wear. A wobbly caster wheel usually indicates a worn bearing.

1. Remove the locknut and wheel bolt holding the caster wheel to the caster fork (Figure 61).

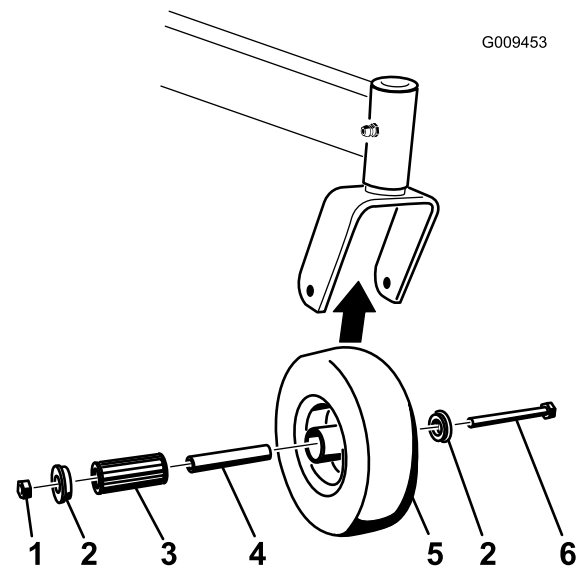

Figure 61

- | | |
|---------------|--------------------|
| 1. Locknut | 4. Spanner Bushing |
| 2. Wheel Bolt | 5. Roller Bearing |
| 3. Bushing | |

2. Remove one bushing, then pull the spanner bushing and roller bearing out of the wheel hub (Figure 61).
3. Remove the other bushing from the wheel hub and clean any grease and dirt from the wheel hub (Figure 61).
4. Inspect the roller bearing, bushings, spanner bushing and inside of the wheel hub for wear. Replace any defective or worn parts (Figure 61).
5. To assemble, place one bushing into the wheel hub. Grease the roller bearing and spanner bushing and slide them into the wheel hub. Place the second bushing into the wheel hub (Figure 61).
6. Install the caster wheel into the caster fork and secure with the wheel bolt and locknut. Tighten the locknut until the spanner bushing bottoms against the inside of the caster forks (Figure 61).
7. Grease the fitting on the caster wheel.

Adjusting the Electric Clutch

Service Interval: Every 100 hours—Check the electric clutch.

The clutch is adjustable to ensure proper engagement and proper braking.

1. Insert a 0.015–0.021 inch (0.381–0.533 mm) feeler gauge through one inspection slot in the side of the assembly. Make sure it is between the armature and the rotor friction surfaces.

The gap needs to be at least .015 inches (0.381 mm) and not more than .021 inches (0.533 mm).

2. If adjustment is needed, use a .015 inch (0.381 mm) feeler gauge to set each of the three adjustment slot positions. Tighten the lock nuts until there is slight binding on the feeler gauge but it can be moved easily within the air gap (Figure 62).
3. Repeat this for the remaining slots.
4. Check each slot again and make slight adjustments until the feeler gauge between the rotor and armature with very slight contact between them.

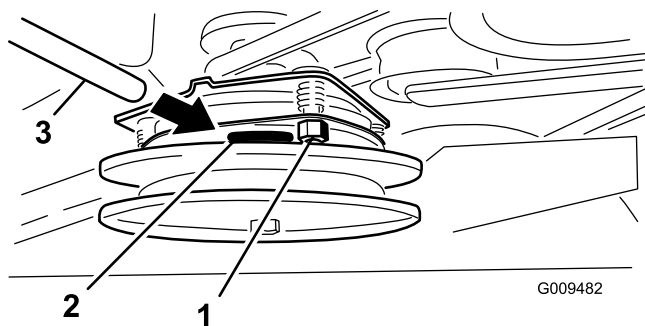

Figure 62

- | | |
|------------------|-----------------|
| 1. Adjusting nut | 3. Feeler gauge |
| 2. Slot | |

Cooling System Maintenance

Cleaning the Air Intake Screen

Service Interval: Before each use or daily

Before each use remove any build-up of grass, dirt or other debris from the cylinder and cylinder head cooling fins, air intake screen on flywheel end, and carburetor-governor levers and linkage. This will help insure adequate cooling and correct engine speed and will reduce the possibility of overheating and mechanical damage to the engine.

Cleaning the Cooling System

Service Interval: Every 100 hours—Check and clean engine cooling fins and shrouds.

1. Disengage the PTO and set the parking brake.
2. Stop the engine, remove the key, and wait for all moving parts to stop before leaving the operating position.
3. Remove the air intake screen and fan housing (Figure 63).
4. Clean the debris and grass from the engine parts.
5. Install air intake screen, recoil starter and fan housing (Figure 63).

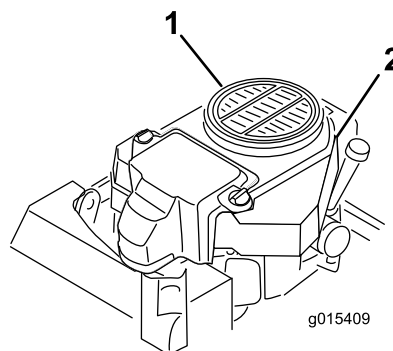

Figure 63

- | | |
|---------------------------------------|----------------|
| 1. Guard and engine air intake screen | 2. Fan housing |
|---------------------------------------|----------------|

Cleaning the Hydraulic Oil Cooler (52 and 60 inch Mower Models Only)

Service Interval: Before each use or daily

Before each use remove any build-up of grass, dirt or other debris from the hydraulic oil cooler and fan. This will help insure adequate cooling and correct engine speed and will reduce the possibility of overheating and mechanical damage to the engine.

Note: High pressure and over-speeding the fan may cause fan failure. Use care with compressed air to avoid over-speeding the electric fan. Never direct a pressure washer on the electric fan.

Servicing the Hydraulic Oil Cooler (52 and 60 inch Mower Models Only)

Service Interval: Every 100 hours—Service the hydraulic oil cooler (in dirty conditions) (if equipped).

1. Keep the hydraulic oil cooler free of debris by cleaning the fins.
2. Blow the hydraulic oil cooler fins to clean away any loose dry debris.
3. Flush the cooler fins clean with water from a water hose to clean away any dirt. A soft brush (i.e. toothbrush) with a soap and water solution may be used to clean the cooler. Do not use a pressure washer.

Note: High pressure and over-speeding the fan may cause fan failure. Use care with compressed air to avoid over-speeding the electric fan. Never direct a pressure washer on the electric fan.

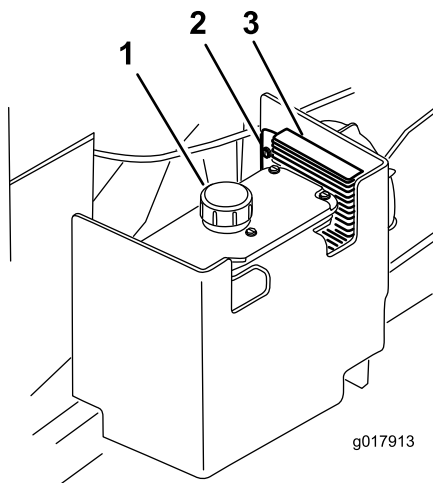

Figure 64

1. Hydraulic tank
2. Bolts
3. Hydraulic oil cooler

Brake Maintenance

Servicing the Brake

Before each use, check brakes on both a level surface and slope.

Always set the parking brake when you stop the machine or leave it unattended. If the parking brake does not hold securely, an adjustment is required.

Checking the Parking Brake

Service Interval: Before each use or daily

1. Park the machine on a level surface, disengage the PTO.
2. Stop the engine, remove the key, and wait for all moving parts to stop before leaving the operating position.
3. Release the brake. The brake bars should lift off the tires and the hand lever should travel forward to the end of the slot in the control panel. Adjust the brake if needed.
4. Engage the brake lever until the brake bars first contact the tire (Figure 65).
5. Measure the gap from the front of the hand lever to the end of the slot in the control panel when the brake bar contacts the tire. This measurement needs to be 3/4 inch (19 mm). Adjust the brake if needed (Figure 65).

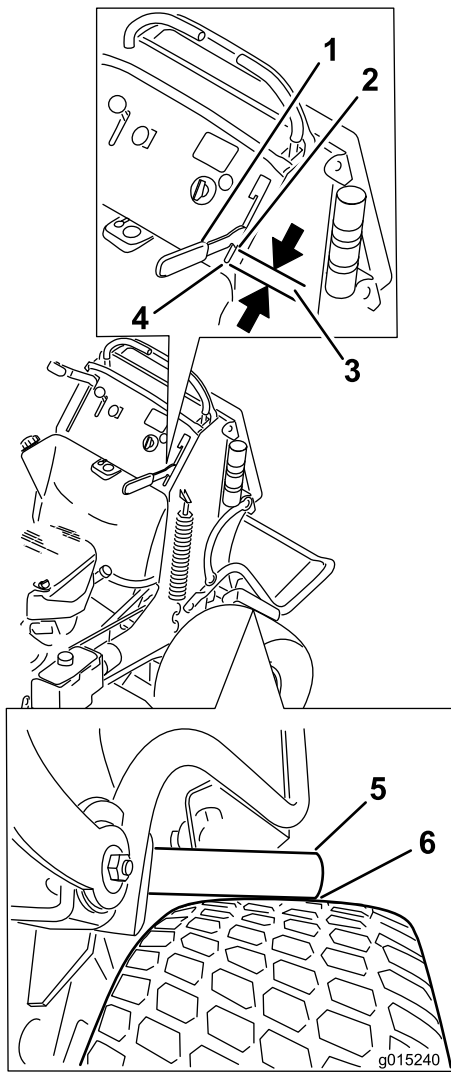

Figure 65

- | | |
|-------------------------|-------------------------------------|
| 1. Hand lever | 4. Front of slot |
| 2. Front of hand lever | 5. Brake bar |
| 3. 3/4 inch (19 mm) gap | 6. Brake bar just touching the tire |

Adjusting the Brakes

If the parking brake does not hold securely, an adjustment is required.

1. Check the brake before you adjust it; refer to Checking the Brakes.
2. Park the machine on a level surface, disengage the PTO, and set the parking brake.
3. Stop the engine, remove the key, and wait for all moving parts to stop before leaving the operating position.
4. Release the parking brake; refer to Releasing the Parking Brake Operation.
5. To adjust the brake, remove the hair pin cotter and clevis pin from the lower brake lever and yoke (Figure 66).
6. Loosen the jam nut (Figure 66).

7. Rotate the yoke. To tighten the brake, rotate the yoke up. To loosen the brake, rotate the yoke down (Figure 66).
8. Secure the yoke to lower brake lever with the hair pin cotter pin and clevis pin (Figure 66).
9. Tighten the jam nut (Figure 66).
10. Check the brake operation again; refer to Checking the Brake.

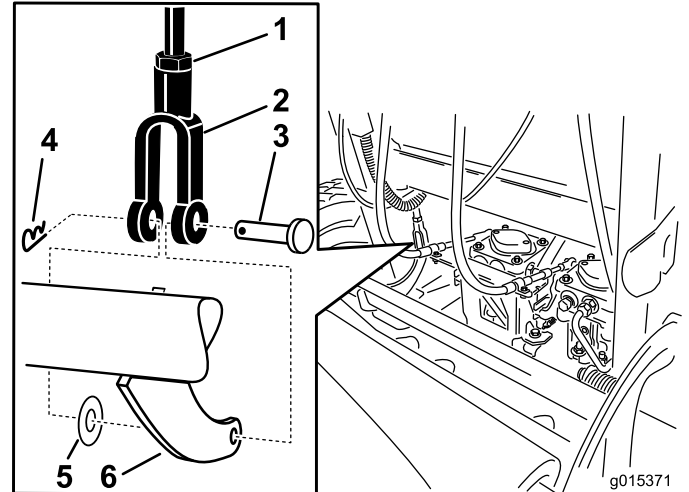

Figure 66

- | | |
|---------------|-----------------------|
| 1. Jam Nut | 4. Hairpin cotter pin |
| 2. Yoke | 5. Flat washer |
| 3. Clevis pin | 6. Lower brake lever |

11. After the brake is adjusted, the lever switch needs to be checked.
12. Check the gap between the brake lever and the face of the switch as shown in Figure 67. The gap needs to be an 1/8 inch (3mm) with the brake **engaged**.
13. If needed, loosen the screws holding the switch and adjust the switch.

Belt Maintenance

Replacing the Mower Deck Belt

Service Interval: Every 100 hours—Check the mower deck belt.

Squealing when the belt is rotating, blades slipping when cutting grass, frayed belt edges, burn marks and cracks are signs of a worn deck belt. Replace the deck belt if any of these conditions are evident.

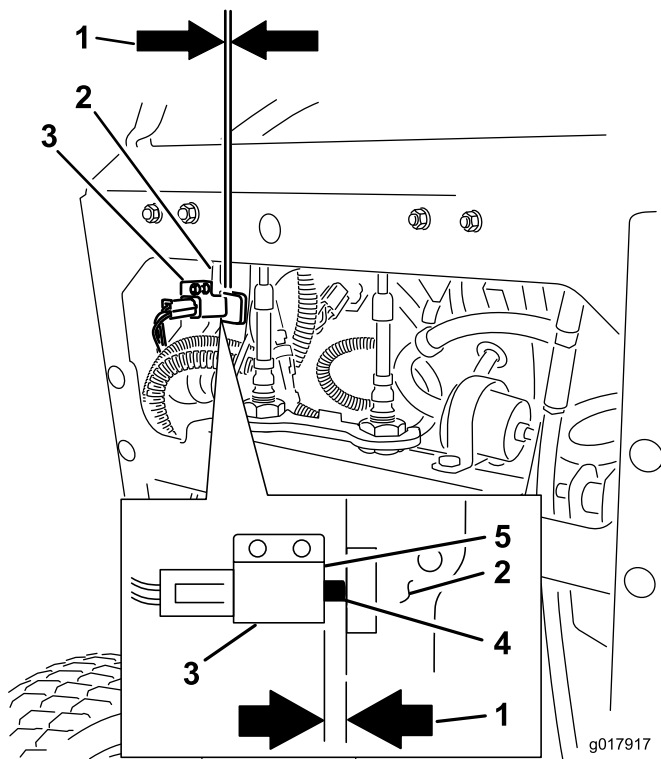

Figure 67

- | | |
|---|-----------------------|
| 1. 1/8 inch (3mm) gap
needed between switch
and brake lever | 4. Switch button |
| 2. Brake lever | 5. Face of the switch |
| 3. Switch | |

1. Disengage the PTO and set the parking brake.
2. Stop the engine, remove the key, and wait for all moving parts to stop before leaving the operating position.
3. Unlatch and remove the belt covers.
4. Loosen the front idler pulley by loosening the nut.
5. Remove the worn mower belt (Figure 68 and Figure 69).
6. Install the new mower belt around the deck pulleys and clutch pulley (Figure 68 and Figure 69).
7. Using a ratchet in the idler arm, tighten the idler pulley until the spring is stretched 6-1/2 inches (165 mm) from hook to hook (Figure 68 and Figure 69).
8. Tighten the front idler pulley by tightening the nut.
9. Install the belt covers onto the cutting unit and secure the latches.

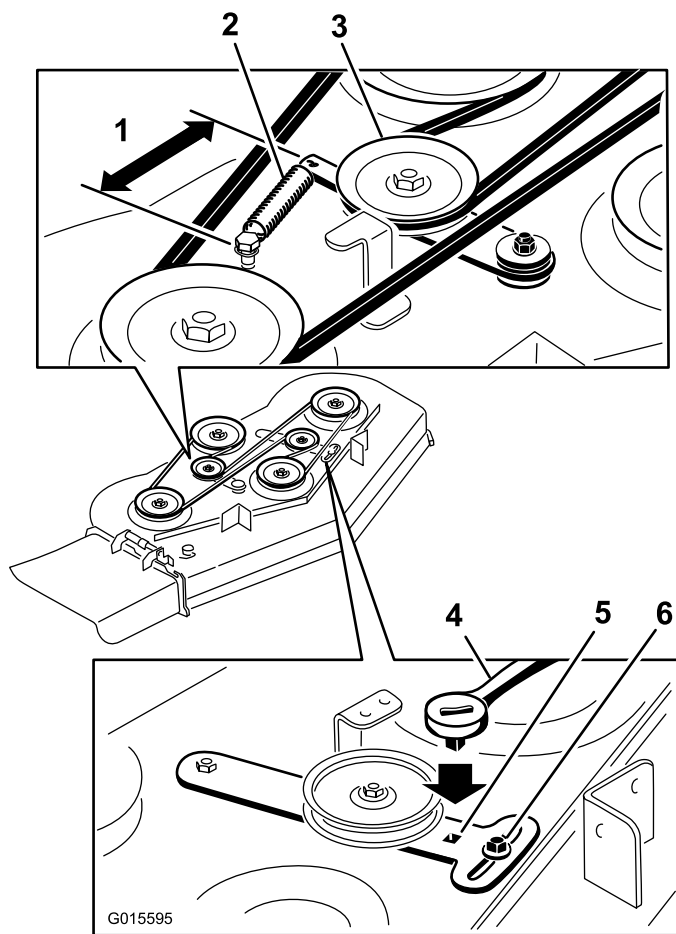

Figure 68

48 and 52 inch mower decks

- | | |
|---|----------------------------|
| 1. 6-1/2 inches (165 mm)
from hook to hook | 4. Ratchet |
| 2. Spring | 5. Square hole for ratchet |
| 3. Spring loaded idler | 6. Nut |

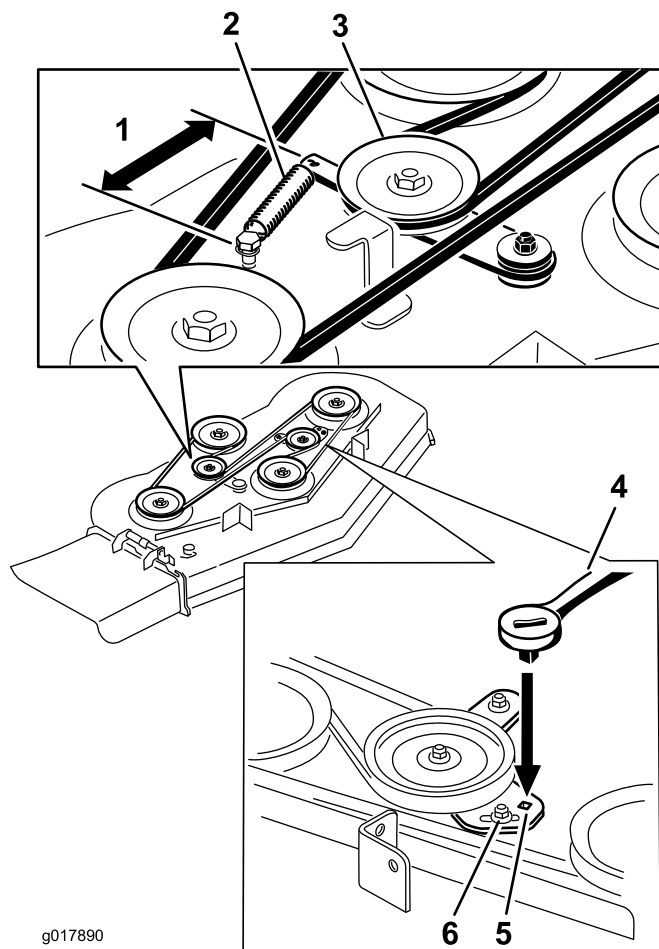

Figure 69

60 inch mower decks

- | | |
|---|----------------------------|
| 1. 6-1/2 inches (165 mm)
from hook to hook | 4. Ratchet |
| 2. Spring | 5. Square hole for ratchet |
| 3. Spring loaded idler | 6. Nut |

Replacing the Pump Drive Belt

Service Interval: Every 100 hours—Check the pump drive belt.

1. Disengage the PTO and set the parking brake.
2. Stop the engine, remove the key, and wait for all moving parts to stop before leaving the operating position.
3. Remove the mower deck belt.
4. Tilt the machine on it's back. Refer to Pre-Maintenance at the beginning of the Maintenance Section.
5. Remove the shoulder bolt, nut and washer from the engine deck and connected to the spring (Figure 70).

Controls System Maintenance

Adjusting the Motion Control Handle Positions

Adjusting the Right Side Motion Control Lever

If the motion control levers do not align horizontally, adjust the right side motion control lever.

Note: Adjust the horizontal alignment before the front to back alignment.

1. Disengage the PTO, move the right side motion control lever to the neutral position and set the parking brake.
2. Stop the engine, remove the key, and wait for all moving parts to stop before leaving the operating position.
3. Push the right motion control lever down out of locked neutral position (Figure 71).
4. Check if it aligns horizontally with the left motion control lever (Figure 71).

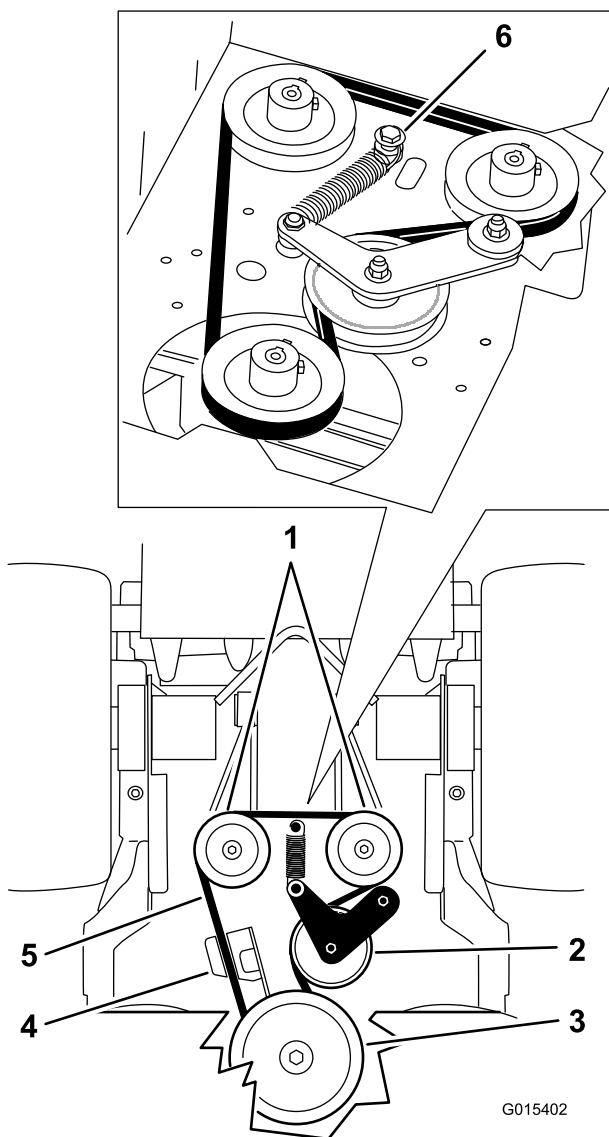

Figure 70

- | | |
|--------------------|---|
| 1. Hydraulic pumps | 4. Clutch retainer |
| 2. Idler pulley | 5. Pump drive belt |
| 3. Clutch pulley | 6. Shoulder bolt, nut and washer connected to engine deck |

6. Remove the pump drive belt (Figure 70).
7. Install the new belt around clutch and the two pump pulleys.
8. Install the spring onto the shoulder bolt and washer and connect it to the engine deck with the nut (Figure 70).
9. Lower the machine to the operating position. Refer to Pre-Maintenance at the beginning of the Maintenance Section.
10. Install the mower deck belt.

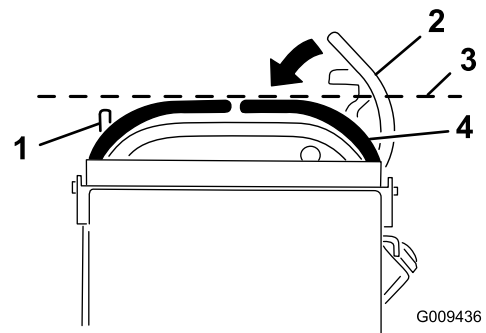

Figure 71

- | | |
|-------------------------------|--|
| 1. Left motion control lever | 3. Check the horizontal alignment here |
| 2. Right motion control lever | 4. Right motion control lever in neutral locked position |

5. To adjust the right motion control lever horizontally, the cam needs to be adjusted.
6. Release the cushion from the rear of the machine.
7. Loosen the nut and bolt holding the cam (Figure 72).
8. Adjust the cam until it aligns with the left motion control lever and tighten the nut and bolt for the cam.

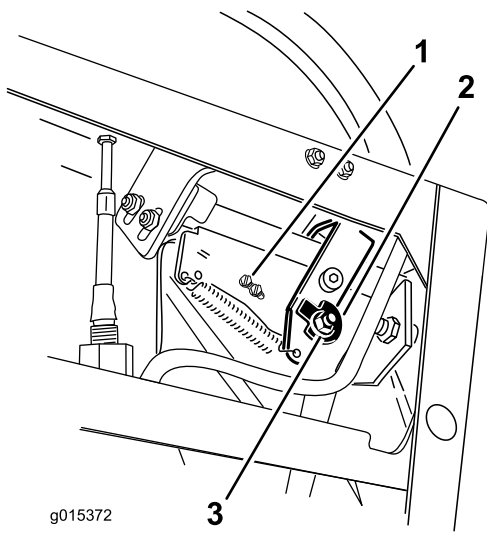

Figure 72

- 1. Switch screws
- 2. Cam
- 3. Nut and bolt

9. After the cam is adjusted, the lever switch needs to be checked.
10. Check the gap between the control lever and switch as shown in Figure 73. The gap needs to be an 1/8 inch (3mm) with the right motion control lever in the neutral, unlocked position.
11. If needed, loosen the screws holding the switch and adjust the switch (Figure 72 and Figure 73).

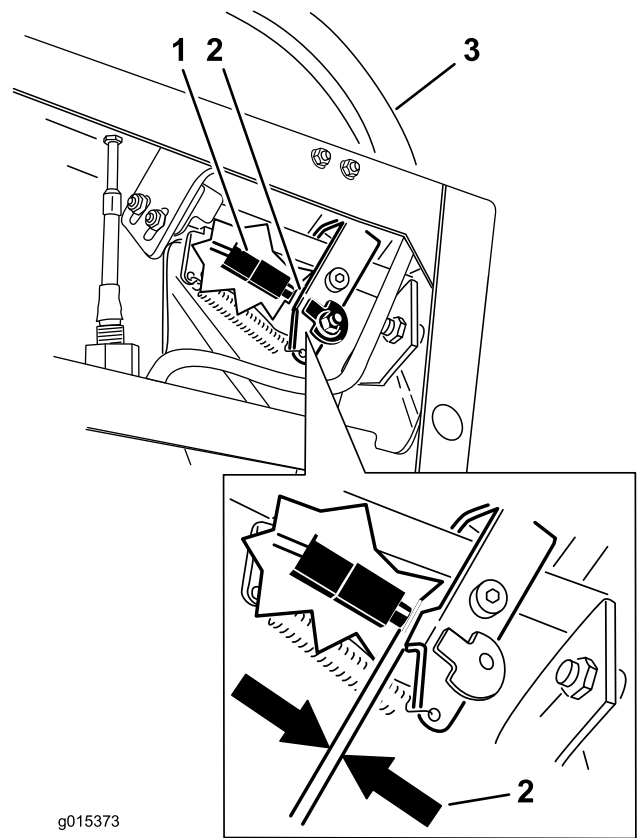

Figure 73

- 1. Switch
- 2. 1/8 inch (3mm)
- 3. Right motion control lever in the neutral unlocked position

12. Tighten the switch screws.

Adjusting the Neutral Position for the Motion Control Levers

Important: Ensure the tracking of the mower is correct after adjusting the motion control levers. Adjusting the tracking and aligning the motion control levers front to back is the same procedure (Figure 74).

Note: Adjust the horizontal alignment before the front to back alignment.

If the motion control levers do not align front to back, or the right side control lever does not move easily into the neutral lock position, adjustment is required.

1. After the horizontal alignment is finished, check the front to back alignment (Figure 74).

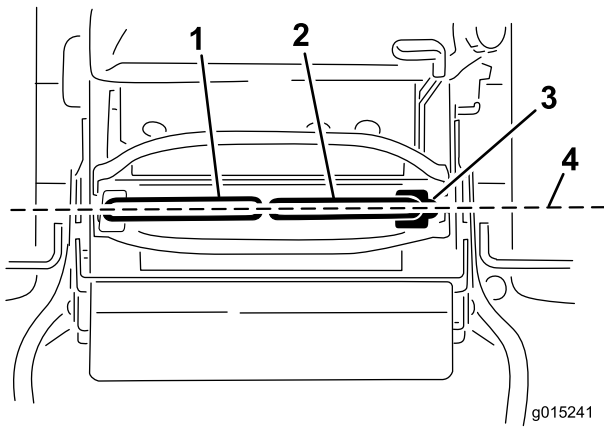

Figure 74

- | | |
|-------------------------------|---|
| 1. Left motion control lever | 3. Neutral locked position |
| 2. Right motion control lever | 4. Align the control levers front to back |

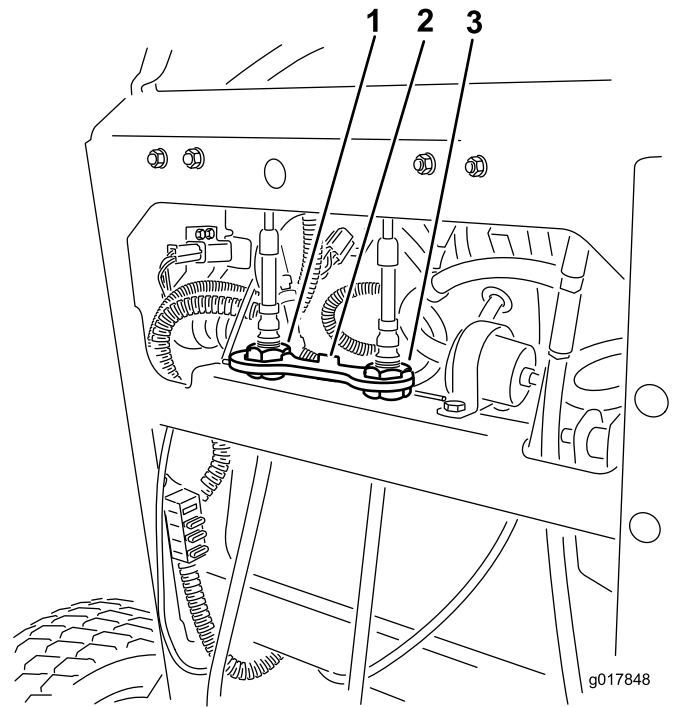

Figure 75

- | | |
|--------------------------|---------------------------|
| 1. Left cable adjustment | 3. Right cable adjustment |
| 2. Cable lock | |

2. Lift and remove the cable lock securing the cable adjusting nuts (Figure 75).
3. Rotate the right cable adjustment to place the right motion control lever in the center of the neutral lock slot in the control panel.
4. Rotate the left cable adjustment to place the left motion control lever alignment equal with the right motion control lever. This will provide an approximate equal tracking of the left wheel speed to the right wheel speed.
5. Check for proper tracking. Refer to Adjusting the Tracking in the Maintenance Section.
6. Install the cable lock onto the cable adjusting nuts to secure the adjustment (Figure 75).

Hydraulic System Maintenance

Servicing the Hydraulic System

Hydraulic Oil Type: Toro® HYPR-OIL™ 500 hydraulic oil or Mobil® 1 15W-50 synthetic motor oil.

Hydraulic System Oil Capacity: 67 oz. (2.0 l)

Important: Use oil specified. Other fluids could cause system damage.

Checking the Hydraulic Fluid

Service Interval: After the first 8 hours

Every 50 hours

Note: There are two ways of checking the hydraulic oil. One is when the oil is warm and one is when the oil is cold. The baffle inside the tank has two levels depending if the oil is warm or cold.

1. Position machine on a level surface.
2. Disengage the power take off (PTO) and shut off the engine.
3. Wait for all moving parts to stop before leaving the operating position and then set the parking brake.
4. Clean area around cap and filler neck of hydraulic tank (Figure 76).

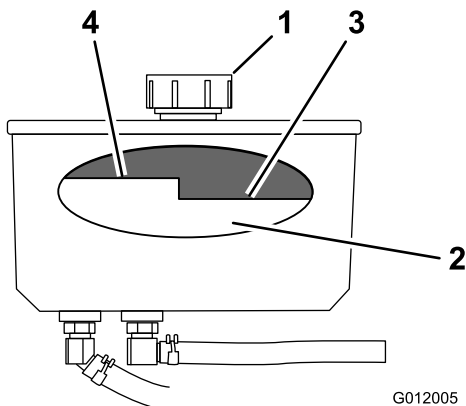

Figure 76

- | | |
|-----------|--------------------------|
| 1. Cap | 3. Cold fluid level-full |
| 2. Baffle | 4. Hot fluid level-full |

5. Remove cap from filler neck. Look inside to check the fluid level in the reservoir. (Figure 76).
6. Add fluid to the reservoir until it reaches the cold level of the baffle.
7. Run the machine at low idle for 15 minutes to allow any air to purge out of the system and warm fluid. Refer to Starting and Stopping the Engine.

8. Recheck the fluid level while the fluid is warm. If required, add fluid to the reservoir until it is between the hot level and the cold level.

Note: The fluid level should be below the hot level of the baffle, when the fluid is warm (Figure 76).

9. Install cap on filler neck.

⚠ WARNING

Hydraulic fluid escaping under pressure can penetrate skin and cause injury.

- If hydraulic fluid is injected into the skin it must be surgically removed within a few hours by a doctor familiar with this type of injury. Gangrene may result if this is not done.
- Keep body and hands away from pin hole leaks or nozzles that eject high pressure hydraulic fluid.
- Use cardboard or paper to find hydraulic leaks.
- Safely relieve all pressure in the hydraulic system before performing any work on the hydraulic system.
- Make sure all hydraulic fluid hoses and lines are in good condition and all hydraulic connections and fittings are tight before applying pressure to hydraulic system.

Replacing the Hydraulic Fluid

Service Interval: Every 250 hours—Change the hydraulic filter and hydraulic oil when using Mobil® 1 oil.

Every 500 hours/Yearly (whichever comes first)—Change the hydraulic filter and hydraulic oil when using Toro® HYPR-OIL™ 500 hydraulic oil.

Note: Change the hydraulic fluid more frequently in severe conditions or in a hot operating climate.

⚠ WARNING

Hot hydraulic fluid can cause severe burns.

Allow the hydraulic fluid to cool before performing any maintenance to the hydraulic system.

1. Disengage the PTO and set the parking brake.
2. Stop the engine and wait for all moving parts to stop before leaving the operating position.
3. Remove hydraulic reservoir cap.

4. Locate the front hydraulic hose under the hydraulic tank and place drain pan under the tank (Figure 77).
5. Loosen the hose clamp and move it down the hose.
6. Remove the front hydraulic hose and allow the fluid to run out of the tank.

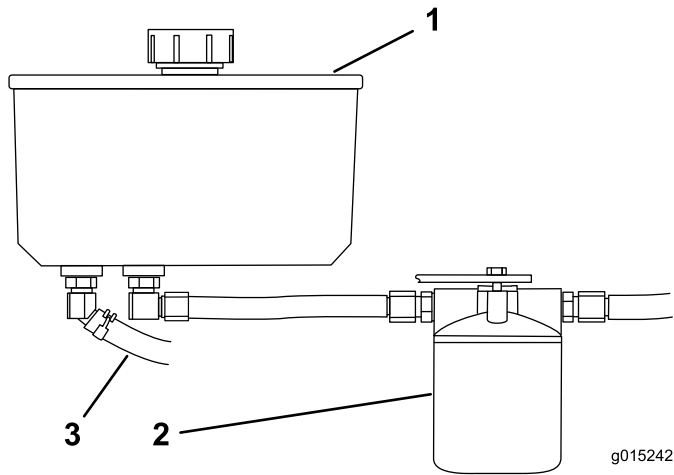

Figure 77

- | | |
|---------------------|-------------------------|
| 1. Hydraulic tank | 3. Front hydraulic hose |
| 2. Hydraulic filter | |

7. Change the hydraulic filter. Refer to Replacing the Hydraulic Filter.
8. Connect the hydraulic hose under the tank.
9. Add fluid to the tank until it reaches the cold baffle of the tank.

Important: Use oil specified or equivalent. Other fluids could cause system damage.

10. Install the hydraulic tank cap.
11. Start engine and let run for about two minutes to purge air from the system. Stop the engine and check for leaks. If one or both wheels will not drive, refer to Bleeding Hydraulic System.
12. Check the level of the fluid and add fluid, if required.
Do not overfill.

Replacing the Hydraulic Filter

Service Interval: After the first 8 hours

▲ WARNING

Hot hydraulic fluid can cause severe burns.

Allow the hydraulic fluid to cool before performing any maintenance to the hydraulic system.

1. Disengage the PTO and set the parking brake.
2. Stop the engine and wait for all moving parts to stop before leaving the operating position.

Important: Do not substitute automotive oil filter or severe hydraulic system damage may result.

3. Locate the filter and place drain pan under filter (Figure 78).

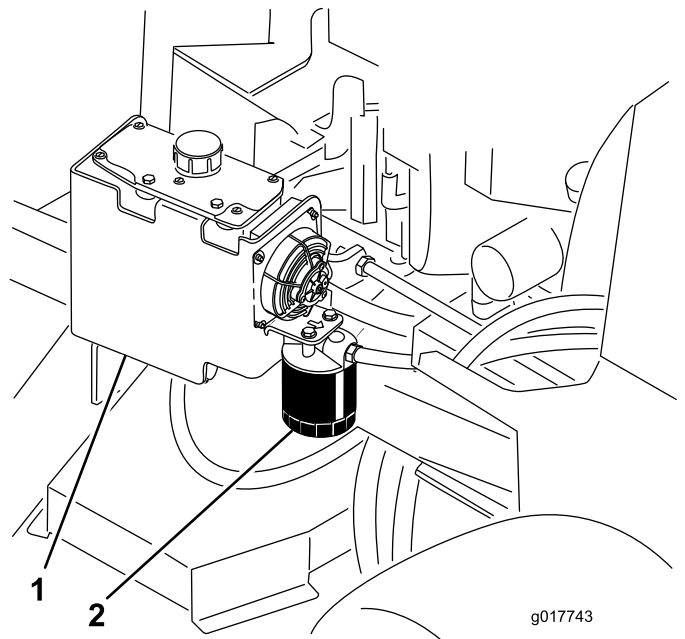

Figure 78

- | | |
|-------------------|---------------------|
| 1. Hydraulic tank | 2. Hydraulic filter |
|-------------------|---------------------|

4. Remove the old filter and wipe the filter adapter gasket surface clean (Figure 79).
5. Apply a thin coat hydraulic fluid to the rubber gasket on the replacement filter.
6. Install replacement hydraulic filter onto the filter adapter. Turn the oil filter clockwise until the rubber gasket contacts the filter adapter, then tighten the filter an additional 1/2 turn (Figure 79).

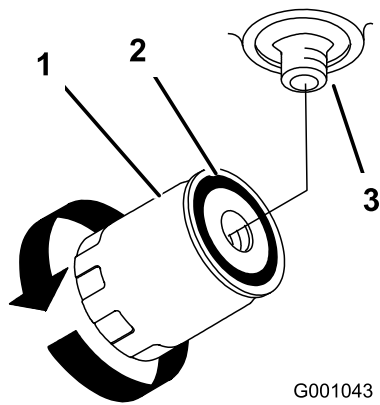

Figure 79

- | | |
|---------------------|------------|
| 1. Hydraulic filter | 3. Adapter |
| 2. Gasket | |

7. Clean up any spilled fluid.
 8. Check the fluid in the reservoir, add fluid to the tank until it reaches the cold baffle of the tank.
- Important:** Use oil specified or equivalent. Other fluids could cause system damage.
9. Start engine and let run for about two minutes to purge air from the system. Stop the engine and check for leaks. If one or both wheels will not drive, refer to Bleeding Hydraulic System.
 10. Recheck level and add fluid, if required. **Do not overfill.**

Bleeding the Hydraulic System

The traction system is self bleeding, however, it may be necessary to bleed the system if fluid is changed or after work is performed on the system.

1. Disengage the PTO and set the parking brake.
2. Stop the engine and wait for all moving parts to stop before leaving the operating position.
3. Raise the rear of the machine up onto jack stands high enough to raise the drive wheels off the ground.
4. Start the engine and move the throttle control to idle position.

If the drive wheel does not rotate, it is possible to assist the purging of the system by carefully rotating the tire in the forward direction.

5. Check the hydraulic fluid level as it drops add fluid as required to maintain the proper level.
6. Repeat this procedure for the opposite wheel.
7. Thoroughly clean the area around each of the charge pump housings.

Checking the Hydraulic Lines

Service Interval: Every 100 hours

Check hydraulic hoses and hoses for leaks, loose fittings, kinked hoses, loose mounting supports, wear, weather and chemical deterioration. Make necessary repairs before operating.

Note: Keep areas around hydraulic system clean from grass and debris build up.

Note: Extended operating time at high temperatures in a hot climate may lead to deterioration of hoses and seals. Inspect more frequently in a hot climate and change hydraulic oil and filter more frequently.

⚠ WARNING

Hydraulic fluid escaping under pressure can penetrate skin and cause injury.

- **If hydraulic fluid is injected into the skin it must be surgically removed within a few hours by a doctor familiar with this type of injury. Gangrene may result if this is not done.**
- **Keep body and hands away from pin hole leaks or nozzles that eject high pressure hydraulic fluid.**
- **Use cardboard or paper to find hydraulic leaks.**
- **Safely relieve all pressure in the hydraulic system before performing any work on the hydraulic system.**
- **Make sure all hydraulic fluid hoses and hoses are in good condition and all hydraulic connections and fittings are tight before applying pressure to hydraulic system.**

Mower Deck Maintenance

Servicing the Cutting Blades

To ensure a superior quality of cut, keep the blades sharp. For convenient sharpening and replacement, you may want to keep extra blades on hand.

⚠ WARNING

A worn or damaged blade can break, and a piece of the blade could be thrown into the operator's or bystander's area, resulting in serious personal injury or death.

- Inspect the blades periodically for wear or damage.
- Replace a worn or damaged blade.

Before Inspecting or Servicing the Blades

Park the machine on a level surface, disengage the blades and set the parking brake. Turn the ignition key to off. Remove the key and disconnect the spark plug wires from the spark plugs.

Inspecting the Blades

Service Interval: Before each use or daily

1. Inspect the cutting edges (Figure 80). If the edges are not sharp or have nicks, remove and sharpen the blades. Refer to Sharpening the Blades.
2. Inspect the blades, especially the curved area. If you notice any cracks, wear, or a slot forming in this area immediately install a new blades (Figure 80).

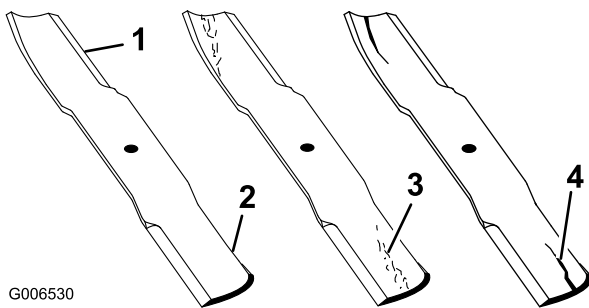

Figure 80

1. Cutting Edge
2. Curved Area
3. Wear/slot Forming
4. Crack

Checking for Bent Blades

1. Disengage the PTO, move the motion control levers to the neutral locked position and set the parking brake.

2. Stop the engine, remove the key, and wait for all moving parts to stop before leaving the operating position.
3. Rotate the blades until the ends face forward and backward. Measure from a level surface to the cutting edge, position A, of the blades (Figure 81). Note this dimension.

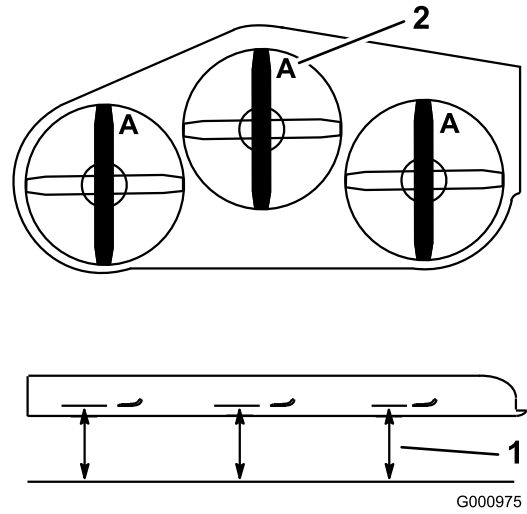

Figure 81

1. Measure here from blade to hard surface
2. Position A

4. Rotate the opposite ends of the blades forward.
5. Measure from a level surface to the cutting edge of the blades at the same position as in step 3 above. The difference between the dimensions obtained in steps 3 and 4 must not exceed 1/8 inch (3 mm). If this dimension exceeds 1/8 inch (3 mm), the blade is bent and must be replaced; refer to Removing the Blades and Installing the Blades.

⚠ WARNING

A blade that is bent or damaged could break apart and could seriously injure or kill you or bystanders.

- Always replace bent or damaged blade with a new blade.
- Never file or create sharp notches in the edges or surfaces of blade.

Removing the Blades

Blades must be replaced if a solid object is hit, if the blade is out of balance or is bent. To ensure optimum performance and continued safety conformance of the machine, use genuine Toro replacement blades. Replacement blades made by other manufacturers may result in non-conformance with safety standards.

1. Hold the blade end using a rag or thickly-padded glove.
2. Remove the blade bolt, curved washer, and blade from the spindle shaft (Figure 82).

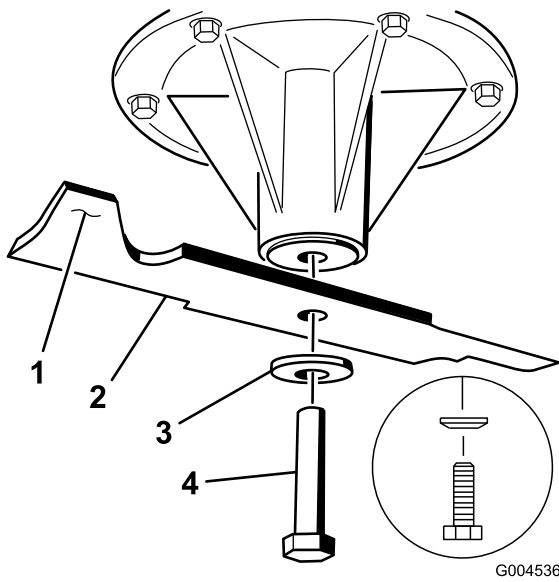

Figure 82

- | | |
|-----------------------|------------------|
| 1. Sail Area of Blade | 3. Curved washer |
| 2. Blade | 4. Blade Bolt |

Sharpening the Blades

1. Use a file to sharpen the cutting edge at both ends of the blade (Figure 83). Maintain the original angle. The blade retains its balance if the same amount of material is removed from both cutting edges.

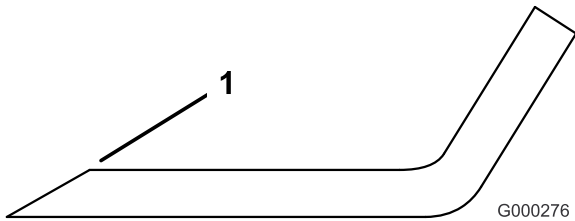

Figure 83

1. Sharpen at original angle

2. Check the balance of the blade by putting it on a blade balancer (Figure 84). If the blade stays in a horizontal position, the blade is balanced and can be used. If the blade is not balanced, file some metal off the end of the sail area only (Figure 82). Repeat this procedure until the blade is balanced.

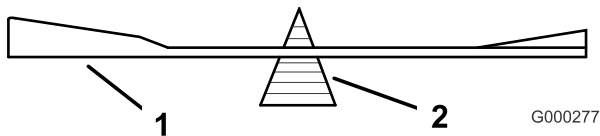

Figure 84

- | | |
|----------|-------------|
| 1. Blade | 2. Balancer |
|----------|-------------|

Installing the Blades

1. Install the blade onto the spindle shaft (Figure 85).

Important: The curved part of the blade must be pointing upward toward the inside of the mower to ensure proper cutting.

2. Install the spring disk and blade bolt. The spring disk cone must be installed toward the bolt head (Figure 85). Torque the blade bolt to 85-110 ft-lb (115-150 N-m).

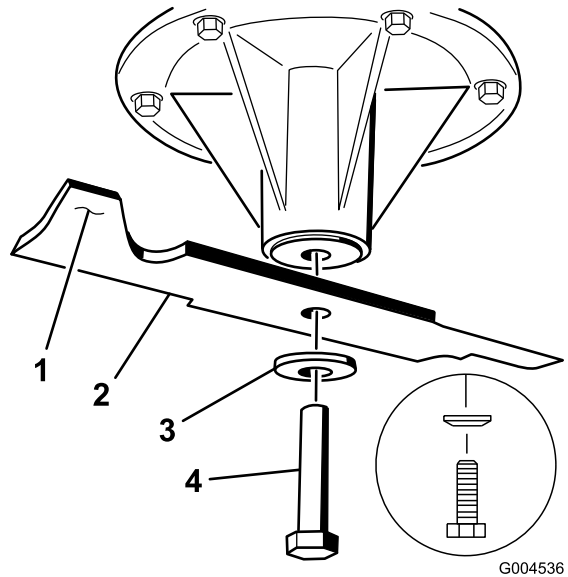

Figure 85

- | | |
|-----------------------|---------------------------|
| 1. Sail Area of Blade | 4. Blade Bolt |
| 2. Blade | 5. Cone Towards Bolt Head |
| 3. Spring Disk | |

Correcting the Mower Quality of Cut

If one deck blade cuts lower than the other, correct as follows.

Note: Tire air pressure is critical in these procedures. Make sure the rear tires have correct pressure.

1. Disengage the PTO and set the parking brake.
2. Stop the engine, remove the key, and wait for all moving parts to stop before leaving the operating position. Disconnect the spark plug wire(s) from the spark plug(s).
3. Adjust the tire pressure in the rear tires to 12-14 psi (83-97 kPa).
4. Check that the blades and spindle shafts are not bent. Refer to Checking for Bent Blades.
5. Set the height-of-cut to the 3 inch (7.6 cm) position. Refer to Adjusting the Height-Of-Cut in Operation.
6. Perform the steps in the following procedures in order.

Checking the Mower Deck Side-to-Side Height

1. Adjust the rear tire pressure.

2. Ensure the blades are not bent. Refer to Checking for Bent Blades.
3. Position the blades side-to-side. Measure at **B** and **C** locations from a level surface to the cutting edge of blade tips (Figure 86).

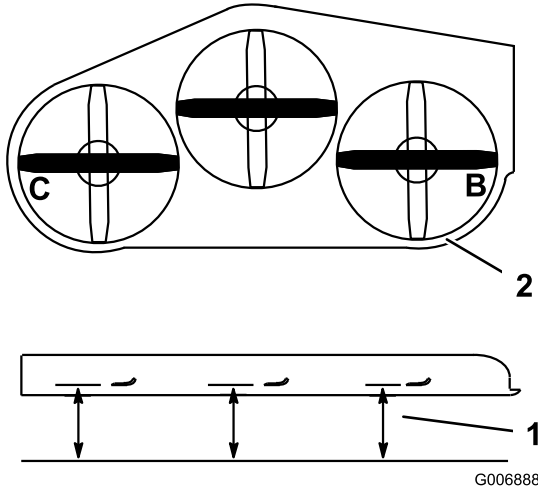

Figure 86

1. Measure from a level surface
2. Measure blade at points **B** and **C**

4. The difference between measurements **B** and **C** should be no more than 1/4 inch (6 mm). If it is not correct, proceed to Changing the Mower Deck Side-to-Side Height.

Changing the Mower Deck Side-to-Side Height

Changing the side-to-side height is done by adjusting the rear tire pressure and U-plates on the side of the engine deck.

1. Change the rear tire pressure. Do this to the corresponding side that needs adjustment.
2. Locate the U-plates on the side of the engine deck (Figure 87).
3. Loosen the U-plate on one side and adjust it up or down to make the difference between measurements **B** and **C** no more than a 1/4 inch (6 mm) (Figure 87).
4. Proceed to Checking the Mower Deck Front-to-Rear Pitch.

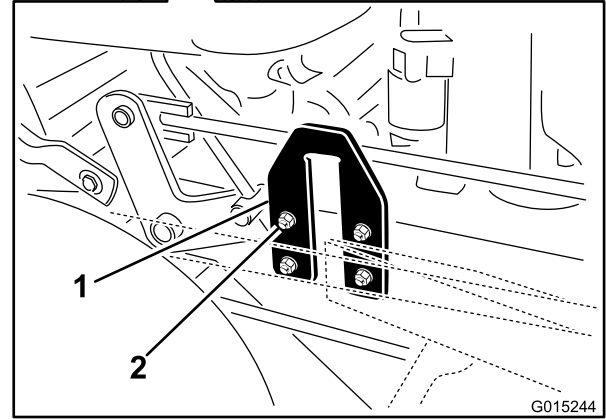
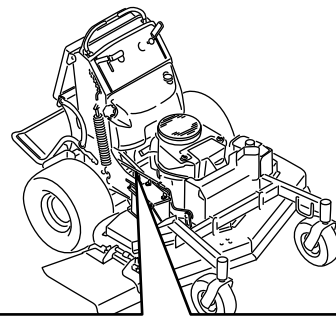

Figure 87

1. U-plate
2. Nuts and bolts

Checking the Mower Deck Front-to-Rear Pitch

1. Adjust the tire pressure in the rear tires to specifications.
2. Position one blade front-to-rear. Measure at **A** and **B** locations from a level surface to the cutting edge of the blade tips (Figure 88).
3. The mower blade should be a 1/4 inch (6 mm) lower in front at **A** than in the rear at **B**. Rotate blades and repeat for other blades. If it is not correct, proceed to Changing the Deck Front-to-Rear Pitch.

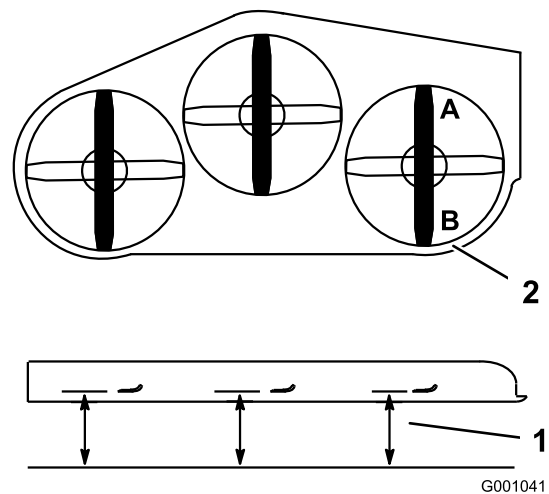

Figure 88

1. Measure blade at points **A** and **B**
2. Measure from a level surface

Changing the Mower Deck Front-to-Rear Pitch

Changing the front-to-rear pitch is done by adjusting the front height-of-cut posts.

1. Place 3 pieces of 2x4 wood under the mower deck as shown in Figure 89. Stand the 2x4's on the 4 inch part.

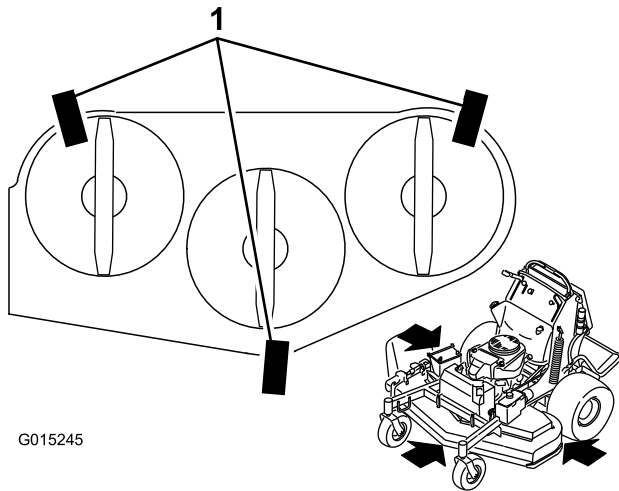

Figure 89

1. 2x4 piece of wood under mower deck

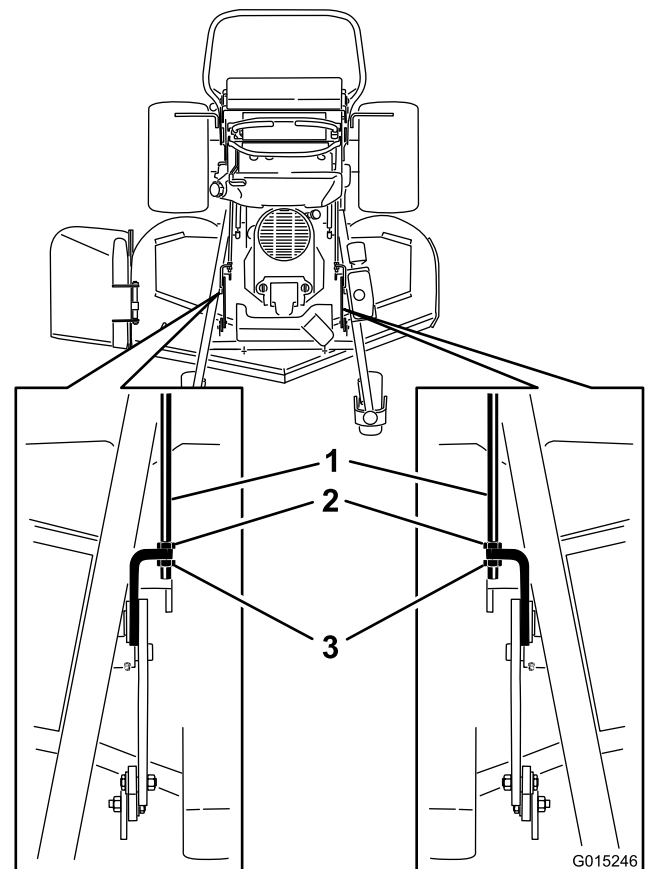

Figure 90
48 and 52 inch mower decks

2. For 48 and 52 inch mower decks, loosen both the front and rear nuts on the adjustment rods (Figure 90).
3. For 60 inch mower decks, loosen both the front and rear nuts and lift links on the adjustment rods (Figure 91).
4. The weight of the mower deck must be resting on all three of the 2x4's (Figure 90). The back lip of the mower deck is built a 1/4 inch (6mm) lower than the front lip of the mower deck.
5. For 60 inch mower decks, tighten the lift links (Figure 91).
6. Tighten both the front and rear nuts.
7. Check the front-to-rear pitch of the cutting unit.
8. If the dimensions are not correct, adjust the front and rear nuts on either side to get the correct front-to-rear pitch (Figure 90).

1. Adjustment rods
2. Rear nuts
3. Front nuts

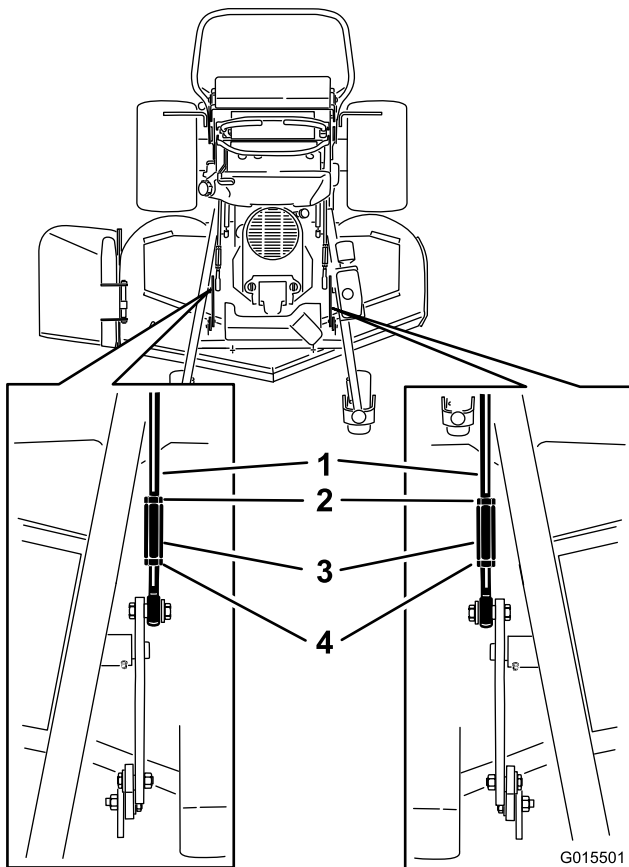

Figure 91
60 inch mower decks

- | | |
|--------------------|---------------|
| 1. Adjustment rods | 3. Lift link |
| 2. Rear nuts | 4. Front nuts |

Matching Height of Cut

1. Check the rear tire pressure.
2. Set the height-of-cut to the 3 inch (7.6 cm) position. Refer to Adjusting the Height-Of-Cut in Operation.
3. With the machine on level surface, position one blade front-to-rear. Measure at **A** and from level surface to the cutting edge of the blade tips (Figure 92).

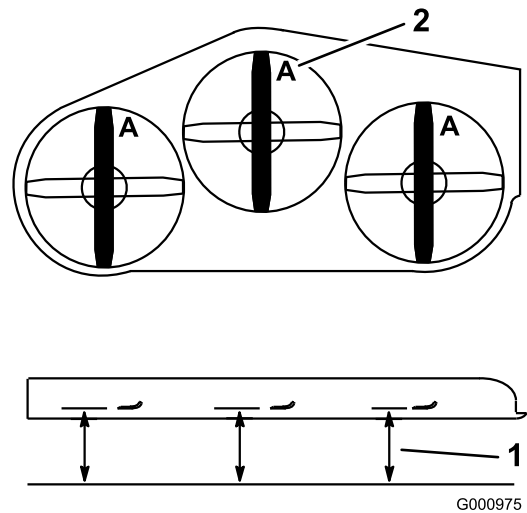

Figure 92

1. Measure from a level surface
2. Measure blade at point **A**

4. The measurement should be 3 inch (7.6 cm).
5. If it does not measure correctly, locate the height-of-cut rod on the right side of the machine (Figure 93).
6. Adjust the adjustment bolt until the blade tips match 3 inches (7.6 cm) (Figure 93).

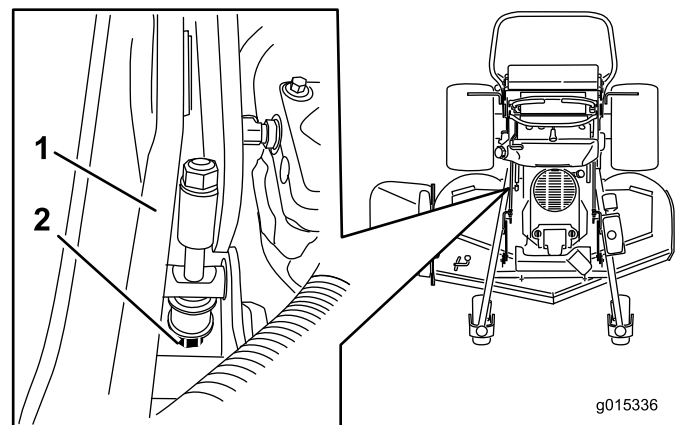

Figure 93

1. Height-of-cut rod
2. Adjustment bolt

Adjusting the Deck Lift Spring

Note: Adjusting the deck lift spring will alter how much the deck will float and how much effort it takes to lift the deck when using the height-of-cut handle.

1. Raise the deck lift lever and lock into the transport position.
2. Check the length between the spring nut and the bottom of the welded U-bracket (Figure 94). Nominal length is between 1.84 to 1.96 inches (47.0 to 50.0 mm) for 48 and 52 inch mower decks and between 1.69 to 1.81 inches (43.0 to 46.0 cm) for 60 inch mower decks (Figure 94).

- If needed, adjust the distance by adjusting the bolt on top of the U-bracket (Figure 94).

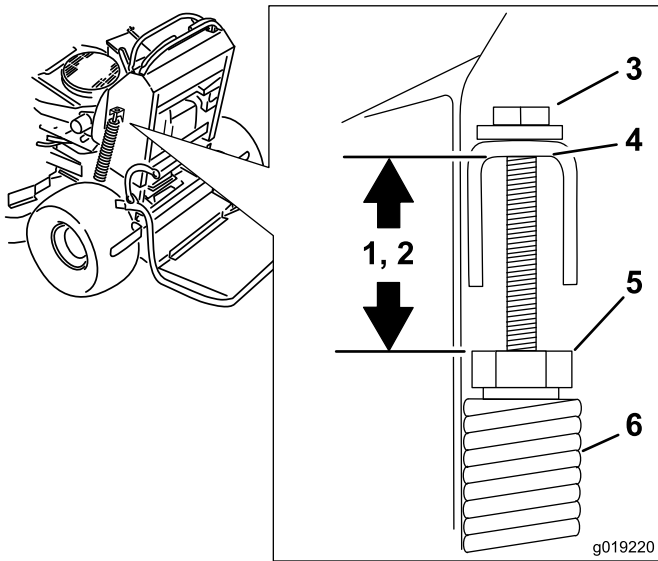

Figure 94

- | | |
|---|-----------------------------------|
| 1. Length is between 1.84 to 1.96 inches (47.0 to 50.0 mm) for 48 and 52 inch mower decks | 4. Bottom of the welded U-bracket |
| 2. Length is between 1.69 to 1.81 inches (43.0 to 46.0 cm) for 60 inch mower decks | 5. Spring nut |
| 3. Adjustment bolt | 6. Deck lift spring |

- Repeat this procedure for the opposite deck lift spring.

Replacing the Grass Deflector

⚠ WARNING

An uncovered discharge opening could allow the lawn mower to throw objects in the operator's or bystander's direction and result in serious injury. Also, contact with the blade could occur.

Never operate the lawn mower unless you install a cover plate, a mulch plate, grass deflector or bagger.

- Remove the locknut, bolt, spring and spacer holding the deflector to the pivot brackets (Figure 95). Remove damaged or worn grass deflector.

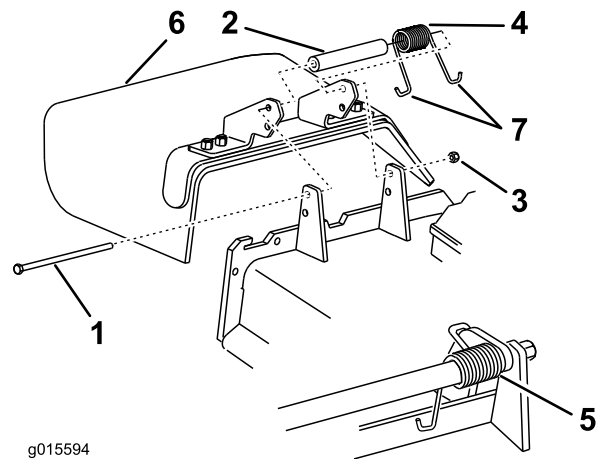

Figure 95

- | | |
|------------|-------------------------|
| 1. Bolt | 5. Spring installed |
| 2. Spacer | 6. Grass Deflector |
| 3. Locknut | 7. J hook end of spring |
| 4. Spring | |

- Place spacer and spring onto grass deflector. Place one J end of spring behind deck edge.

Note: Make sure one J end of spring is installed behind deck edge before installing the bolt as shown in Figure 95.

- Install bolt and nut. Place one J hook end of spring around grass deflector (Figure 95).

Important: The grass deflector must be able to rotate. Lift the deflector up to the full open position and ensure that it rotates into the full down position.

Cleaning

Cleaning Under the Mower

Service Interval: Before each use or daily

Remove the grass buildup under the mower daily.

1. Disengage the PTO, move the motion control levers to the neutral locked position and set the parking brake.
2. Stop the engine, remove the key, and wait for all moving parts to stop before leaving the operating position.
3. Raise the front of the machine and use jack stands to support the mower.

Waste Disposal

Engine oil, batteries, hydraulic oil, and engine coolant are pollutants to the environment. Dispose of these according to your state and local regulations.

Storage

Cleaning and Storage

1. Disengage the power take off (PTO), set the parking brake, and turn the ignition key to off. Remove the key.
2. Remove grass clippings, dirt, and grime from the external parts of the entire machine, especially the engine. Clean dirt and chaff from the outside of the engine's cylinder head fins and blower housing.

Important: You can wash the machine with mild detergent and water. Do not pressure wash the machine. Avoid excessive use of water, especially near the drive system and engine. Pressure washing can force dirt and water into critical parts, such as spindle bearings and electrical switches.

3. Check the brake; refer to Servicing the Brake in Brake Maintenance (page 43).
4. Service the air cleaner; refer to Servicing the Air Cleaner in Engine Maintenance (page 32).
5. Grease the machine; refer to Greasing and Lubrication in Lubrication (page 30).
6. Change the engine oil; refer to Servicing the Engine in Engine Maintenance (page 32).
7. Check the tire pressure; refer to Checking the Tire Pressure in Drive System Maintenance (page 39).
8. For long-term storage:
 - A. Add stabilizer/conditioner additive to fuel in the tank.
 - B. Run engine to distribute conditioned fuel through the fuel system (5 minutes).
 - C. Stop engine, allow to cool and drain the fuel tank; refer to Servicing the Fuel Tank in Fuel System Maintenance (page 36), or operate engine until it stops.
 - D. Restart engine and run until it stops. Repeat, on Choke until engine will not restart.
 - E. Dispose of fuel properly. Recycle as per local codes.

Note: Do not store stabilizer/conditioned gasoline over 90 days.
9. Remove the spark plug(s) and check its condition; refer to Servicing the Spark Plug in Engine Maintenance (page 32). With the spark plug(s) removed from the engine, pour two tablespoons of engine oil into the spark plug hole. Now use the starter to crank the engine and distribute the oil inside the cylinder. Install the spark plug(s). Do not install the wire on the spark plug(s).
10. Check and tighten all bolts, nuts, and screws. Repair or replace any part that is damaged or defective.

11. Paint all scratched or bare metal surfaces. Paint is available from your Authorized Service Dealer.
12. Store the machine in a clean, dry garage or storage area. Remove the key from the ignition switch and keep it in a memorable place. Cover the machine to protect it and keep it clean.

Troubleshooting

Problem	Possible Cause	Corrective Action
Engine will not start, starts hard, or fails to keep running.	<ol style="list-style-type: none"> 1. Fuel tank is empty or shut-off valve closed. 2. Choke is not on. 3. Spark plug wire is loose or disconnected. 4. Spark plug is pitted, fouled, or the gap is incorrect. 5. Air cleaner is dirty. 6. Dirt in the fuel filter. 7. Dirt, water, or stale fuel is in the fuel system. 8. The gap between the safety interlock switches is not correct. 	<ol style="list-style-type: none"> 1. Fill fuel tank with gasoline and open valve 2. Move the choke lever to choke position. 3. Install wire on spark plug. 4. Install a new, correctly gapped spark plug. 5. Service the air cleaner element. 6. Replace the fuel filter. 7. Contact an Authorized Service Dealer. 8. Contact an Authorized Service Dealer.
Engine loses power.	<ol style="list-style-type: none"> 1. Engine load is excessive. 2. Air cleaner is dirty. 3. Oil level in the crankcase is low. 4. Cooling fins and air passages under the engine blower housing are plugged. 5. Spark plug is pitted, fouled, or the gap is incorrect. 6. Vent hole in the fuel cap is plugged. 7. Dirt in the fuel filter. 8. Dirt, water, or stale fuel is in the fuel system. 	<ol style="list-style-type: none"> 1. Reduce the ground speed. 2. Service the air cleaner. 3. Add oil to the crankcase. 4. Remove the obstruction from the cooling fins and air passages. 5. Install a new, correctly gapped spark plug. 6. Clean or replace the fuel cap. 7. Replace the fuel filter. 8. Contact an Authorized Service Dealer.
Engine overheats.	<ol style="list-style-type: none"> 1. Engine load is excessive. 2. Oil level in the crankcase is low. 3. Cooling fins and air passages under the engine blower housing are plugged. 	<ol style="list-style-type: none"> 1. Reduce the ground speed. 2. Add oil to the crankcase. 3. Remove the obstruction from the cooling fins and air passages.
Machine does not drive.	<ol style="list-style-type: none"> 1. Hydraulic oil reservoir low. 2. Air in the hydraulic system. 3. Pump drive belt slipping. 4. Pump drive belt idler spring missing. 5. Pump by-pass valves are open. 	<ol style="list-style-type: none"> 1. Add hydraulic oil to the reservoir. 2. Bleed the air out the hydraulic system. 3. Replace the pump drive belt. 4. Replace the pump drive belt idler spring. 5. Tighten the by-pass valves. Torque to 110 to 130 in-lb (12 to 15 N-m).
Abnormal vibration.	<ol style="list-style-type: none"> 1. Cutting blade(s) is/are bent or unbalanced. 2. Blade mounting bolt is loose. 3. Engine mounting bolts are loose. 4. Loose engine pulley, idler pulley, or blade pulley. 5. Engine pulley is damaged. 6. Blade spindle is bent. 	<ol style="list-style-type: none"> 1. Install new cutting blade(s). 2. Tighten the blade mounting bolt. 3. Tighten the engine mounting bolts. 4. Tighten the appropriate pulley. 5. Contact an Authorized Service Dealer. 6. Contact an Authorized Service Dealer.

Problem	Possible Cause	Corrective Action
Uneven cutting height.	<ol style="list-style-type: none"> 1. Blade(s) not sharp. 2. Cutting blade(s) is/are bent. 3. Mower deck is not level. 4. Mower deck pitch is wrong. 5. Underside of mower deck is dirty. 6. Tire pressure is not correct. 7. Blade spindle bent. 	<ol style="list-style-type: none"> 1. Sharpen the blade(s). 2. Install new cutting blade(s). 3. Level the mower deck side-to-side position. 4. Adjust the front-to-rear pitch. 5. Clean the underside of the mower deck. 6. Adjust the tire pressure. 7. Contact an Authorized Service Dealer.
Blades do not rotate.	<ol style="list-style-type: none"> 1. Pump drive belt is worn, loose or broken. 2. Pump drive belt is off pulley. 3. Mower deck belt is worn, loose or broken. 4. Mower deck belt is off pulley. 5. Broken or missing idler spring. 6. Electric clutch out of adjustment. 7. Clutch connector or wire damaged. 8. Damaged electric clutch. 9. Safety interlock system prevents blade rotation. 10. PTO switch is faulty. 	<ol style="list-style-type: none"> 1. Check the belt tension. 2. Install drive belt and check adjusting shafts and belt guides for correct position. 3. Install new deck belt. 4. Install deck pulley and check the idler pulley, idler arm and spring for correct position and function. 5. Replace the spring. 6. Adjust the clutch air gap. 7. Contact an Authorized Service Dealer. 8. Contact an Authorized Service Dealer. 9. Contact an Authorized Service Dealer. 10. Contact an Authorized Service Dealer.

Schematics

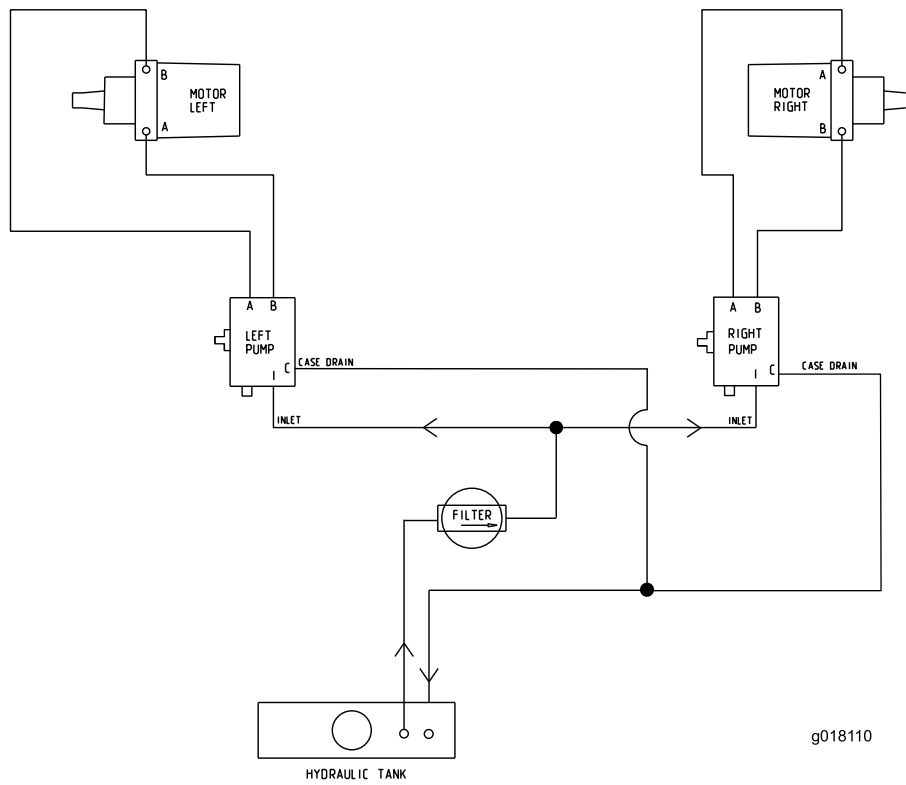

Hydraulic Schematic for 48 inch Mower Models (Rev. A)

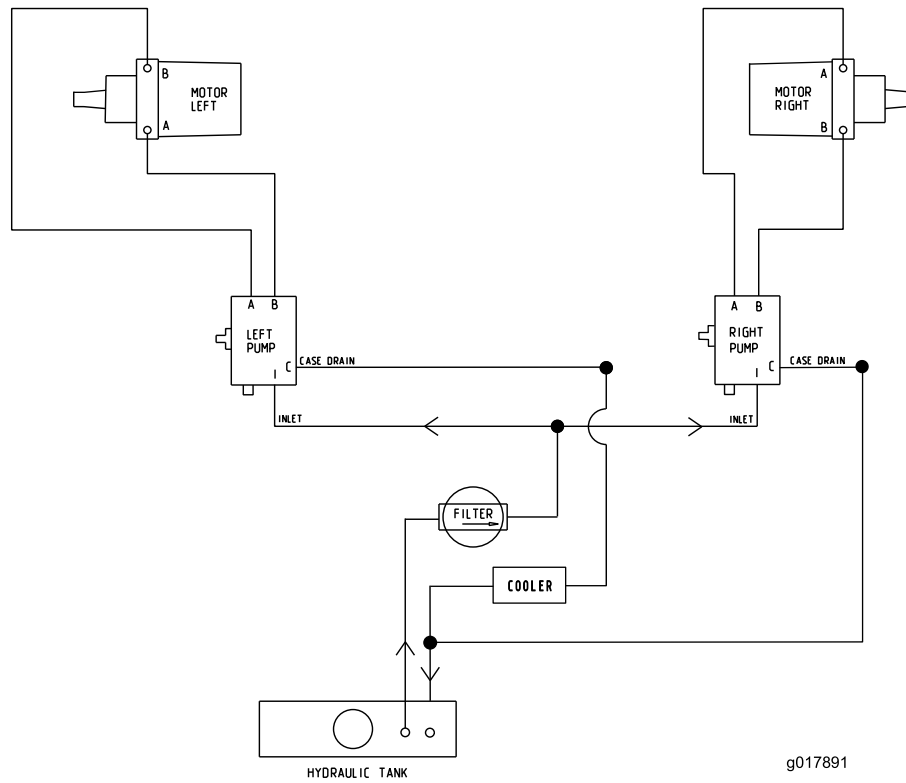

Hydraulic Schematic for 52 and 60 inch Mower Models (Rev. A)

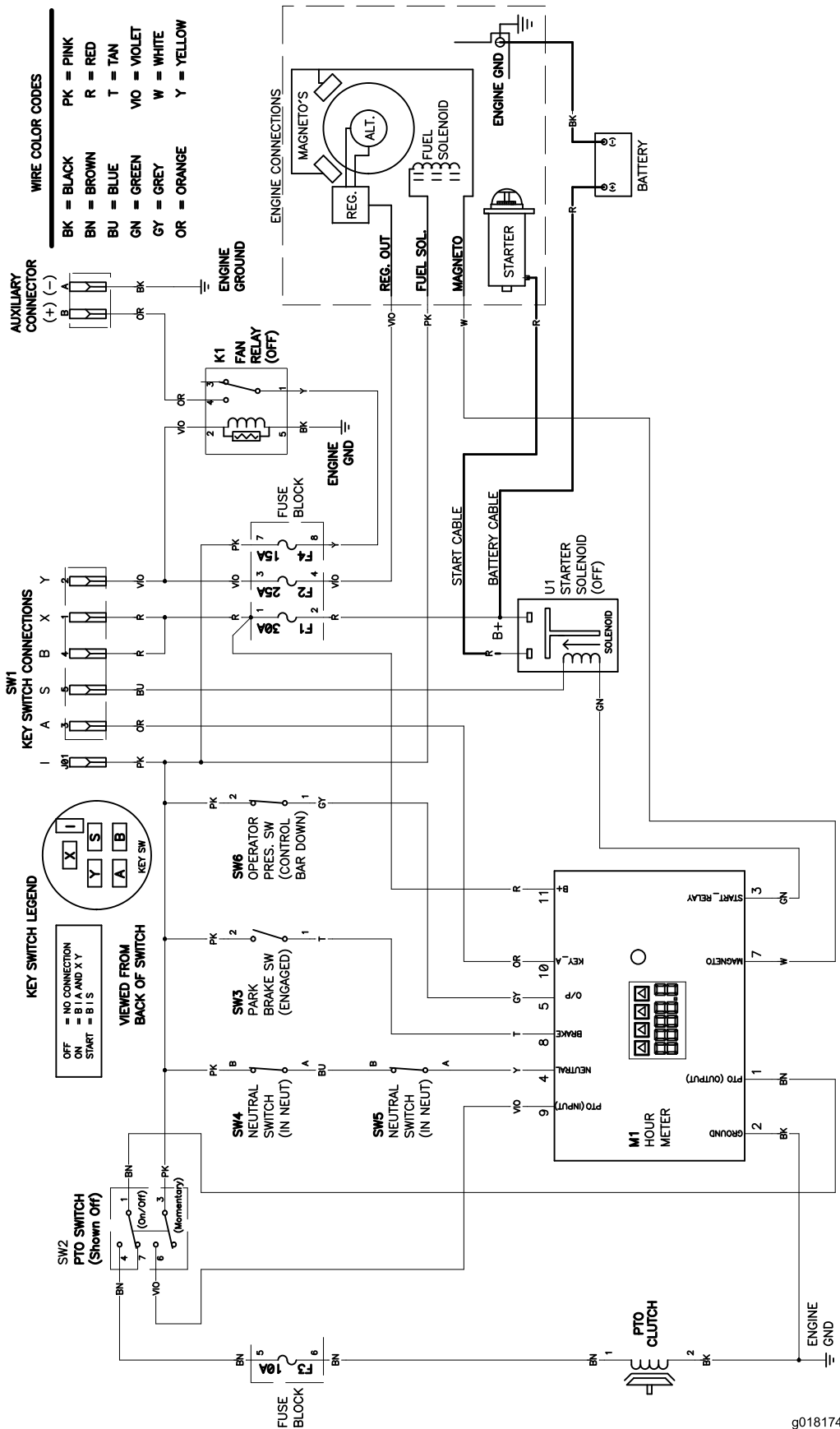

Electrical Schematic for 52 and 60 inch Mower Models (Rev. A)

g018174

Notes:

Notes:



The Toro Total Coverage Warranty

A Limited Warranty (see warranty periods below)

Landscape Contractor Equipment (LCE)

Conditions and Products Covered

The Toro Company and its affiliate, Toro Warranty Company, pursuant to an agreement between them, jointly promise to the original purchaser to repair the Toro Products listed below if defective in materials or workmanship.

The following time periods apply from the date of purchase by the original owner:

Products	Warranty Period
21 in. Mowers • Engines ⁴	1 year Commercial Use Honda – 1 years Kawasaki – 3 years
21 in. Mowers • Engines ⁴	2 years Residential Use ¹ Honda – 2 years Kawasaki – 3 years
Mid-Size Walk-Behind Mowers • Engines ⁴	2 years Kawasaki – 3 years
Grand Stand® Mowers • Engines ⁴ • Frame	5 years or 1,200 hours ² Kawasaki – 3 years Kohler EFI – 3 years Lifetime (original owner only) ³
Z Master® 2000 Series Mowers • Engines ⁴ • Frame	4 years or 500 hours ² Kawasaki – 3 years Lifetime (original owner only) ³
Z Master® 3000 Series Mowers • Engines ⁴ • Frame	5 years or 1,200 hours ² Kawasaki – 3 years Lifetime (original owner only) ³
Z Master® 5000 Series Mowers • Engines ⁴ • Frame	5 years or 1,200 hours ² Kohler Command – 2 years Kohler EFI – 3 years Lifetime (original owner only) ³
Z Master® 6000 Series Mowers • Engines ⁴ • Frame	5 years or 1,200 hours ² Kawasaki – 3 years Kohler Command – 2 years Kohler EFI – 3 years Lifetime (original owner only) ³
Z Master®7000 Series Mowers • Engines ⁴ • Frame	4 years or 1,200 hours ² Kubota – 2 years Briggs & Stratton – 2 years Lifetime (original owner only) ³
All Mowers • Battery	90 days Parts and Labor 1 year Parts only
• Belts and Tires	90 days
• Attachments	1 year

¹Residential use means use of the product on the same lot as your home. Use at more than one location is considered commercial use and the commercial warranty would apply.

²Whichever occurs first.

³Lifetime Frame Warranty - If the main frame, consisting of the parts welded together to form the tractor structure that other components such as the engine are secured to, cracks or breaks in normal use, it will be repaired or replaced, at Toro's option, under warranty at no cost for parts and labor. Frame failure due to misuse or abuse and failure or repair required due to rust or corrosion are not covered.

⁴Some engines used on Toro Products are warranted by the engine manufacturer.

This warranty includes the cost of parts and labor, but you must pay transportation costs.

Instructions for Obtaining Warranty Service

If you think that your Toro Product contains a defect in materials or workmanship, follow this procedure:

1. Contact any Authorized Toro Service Dealer to arrange service at their dealership. To locate a dealer convenient to you, refer to the Yellow Pages of your telephone directory (look under "Lawn Mowers") or access our web site at www.Toro.com. You may also call the numbers listed in item #3 to use the 24-hour Toro Dealer locator system.
2. Bring the product and your proof of purchase (sales receipt) to the Service Dealer. The dealer will diagnose the problem and determine if it is covered under warranty.
3. If for any reason you are dissatisfied with the Service Dealer's analysis or with the assistance provided, contact us at:

RLC Customer Care Department
Toro Warranty Company
8111 Lyndale Avenue South
Bloomington, MN 55420-1196
888-865-5676 (U.S. Customers)
888-865-5691 (Canada customers)

Owner Responsibilities

You must maintain your Toro Product by following the maintenance procedures described in the *Operator's Manual*. Such routine maintenance, whether performed by a dealer or by you, is at your expense.

Items and Conditions Not Covered

There is no other express warranty except for special emission system and engine warranty coverage on some products. This express warranty does not cover the following:

- Cost of regular maintenance service or wear parts, such as filters, fuel, lubricants, tune-up parts, blade sharpening, brake and clutch adjustments.
- Any product or part which has been altered or misused and requires replacement or repair due to normal wear, accidents, or lack of proper maintenance.
- Repairs necessary due to improper fuel, contaminants in the fuel system, or failure to properly prepare the fuel system prior to any period of non-use over three months.
- Pickup and delivery charges.

General Conditions

All repairs covered by these warranties must be performed by an Authorized Toro Service Dealer using Toro approved replacement parts.

Neither The Toro Company nor Toro Warranty Company is liable for indirect, incidental or consequential damages in connection with the use of the Toro Products covered by this warranty, including any cost or expense of providing substitute equipment or service during reasonable periods of malfunction or non-use pending completion of repairs under this warranty.

All implied warranties of merchantability (that the product is fit for ordinary use) and fitness for use (that the product is fit for a particular purpose) are limited to the duration of the express warranty.

Some states do not allow exclusions of incidental or consequential damages, or limitations on how long an implied warranty lasts, so the above exclusions and limitations may not apply to you.

This warranty gives you specific legal rights, and you may also have other rights which vary from state to state.

Countries Other than the United States or Canada

Customers who have purchased Toro products outside the United States or Canada should contact their Toro Distributor (Dealer) to obtain guarantee policies for your country, province, or state. If for any reason you are dissatisfied with your Distributor's service or have difficulty obtaining guarantee information, contact the Toro importer. If all other remedies fail, you may contact us at Toro Warranty Company.