



**Count on it.**

**Parts Catalog**

**Z Master® Riding Mower  
with 48in TURBO FORCE® Side Discharge  
Mower**

**Model No. 74141—Serial No. 312000001 and Up**



# Ordering Replacement Parts

To order replacement parts, please supply the part number, the quantity, and the description of each part desired.

## Understanding Reference Numbers

Each identified part in an illustration has a reference number. The reference number for a part also appears in the parts list, along with other information about the part.

This catalog uses two special reference number formats, one to indicate parts in a service assembly and another to indicate the quantity of a given part in an illustration.

## Service Assembly Reference Numbers

Parts in service assemblies have reference numbers in the form a:b. The a represents the reference number of the entire service assembly and the b represents a sequential number unique to each part within the service assembly.

For example, a wheel assembly might be identified by reference number 6, the tire by 6:1, the valve by 6:2, and the wheel by 6:3. When you order the assembly identified by reference number 6, you receive all parts identified by reference numbers 6:1, 6:2, and 6:3. However, you may also order any part individually. Reference numbers of this type appear in illustration and in parts lists.

## Reference Numbers Indicating Quantity

In an illustration, if a reference number indicates more than one part, the reference number has the form nX y. The n represents the quantity of the part, the X is the multiplication symbol, and the y represents the reference number.

For example, in an illustration, the reference number 2X 37 means that two of the parts identified by reference number 37 are indicated.

# List of Abbreviations

**AR:** as required

**ASM:** assembly

**BBC:** blade brake control

**BHTF:** button head thread forming

**CARR:** carriage

**CCW:** counter clockwise

**CW:** clockwise

**DEG:** degrees

**DPA:** Dual Point Adjustment

**ECM:** electronic control module

**EXT:** external

**FH:** flat head

**GA:** gauge

**HD:** heavy-duty

**HF:** hex flange

**HH:** hex head

**HHF:** hex head flange

**HHFTF:** hex head flange thread forming

**HJ:** hex jam

**HLH:** hex lag head

**HOC:** height-of-cut

**HSBH:** hex socket button head

**HSFH:** hex socket flat head

**HSH:** hex socket head

**HWH:** hex washer head

**HWTF:** hex washer head thread forming

**HYD:** hydraulic

**LH:** left hand

**LPG:** Liquid Propane Gas

**NI:** nylon insert

**NPTF:** national pipe thread fine

**PFH:** phillips flat head

**PPH:** phillips pan head

**PPHTF:** phillips pan head thread forming

**PRH:** phillips round head

**PTH:** phillips truss head

**PTO:** power-take-off

**RH:** right hand

**ROPS:** roll-over protection system

**RRB:** rear roller brush

**SFH:** slotted fillister head

**SHH:** slotted hex head

**SHWH:** slotted hex washer head

**SPH:** slotted pan head

**SQH:** square head

**SRH:** slotted round head

**STD:** standard

**TAP:** self tapping

**TTH:** torx truss head

# Contents

Frame and Caster Wheel Assembly .....	4
Roll-Over Protection System Assembly No. 116-0231 .....	5
Caster Fork and Wheel Assembly .....	6
Hydro Drive System Assembly .....	7
RH Transaxle Assembly No. 120-7861 .....	8
LH Transaxle Assembly No. 120-7860 .....	10
Hydro Idler Arm Assembly .....	12
Fuel Tank and Hose Assembly .....	13
Seat Mounting Assembly .....	14
Seat Assembly No. 120-7886 .....	15
Motion Control Assembly .....	16
Parking Brake Assembly .....	17
Engine, Muffler and Control Panel Assembly .....	18
Deck Lift Assembly .....	20
Height-of-Cut Assembly No. 120-2520 .....	21
Deck Assembly .....	22
Deck Decal Assembly No. 120-2441 .....	24
Deflector Assembly No. 120-2451 .....	25
Idler Assembly .....	26
Electrical Assembly .....	27
Attachments and Accessories .....	28

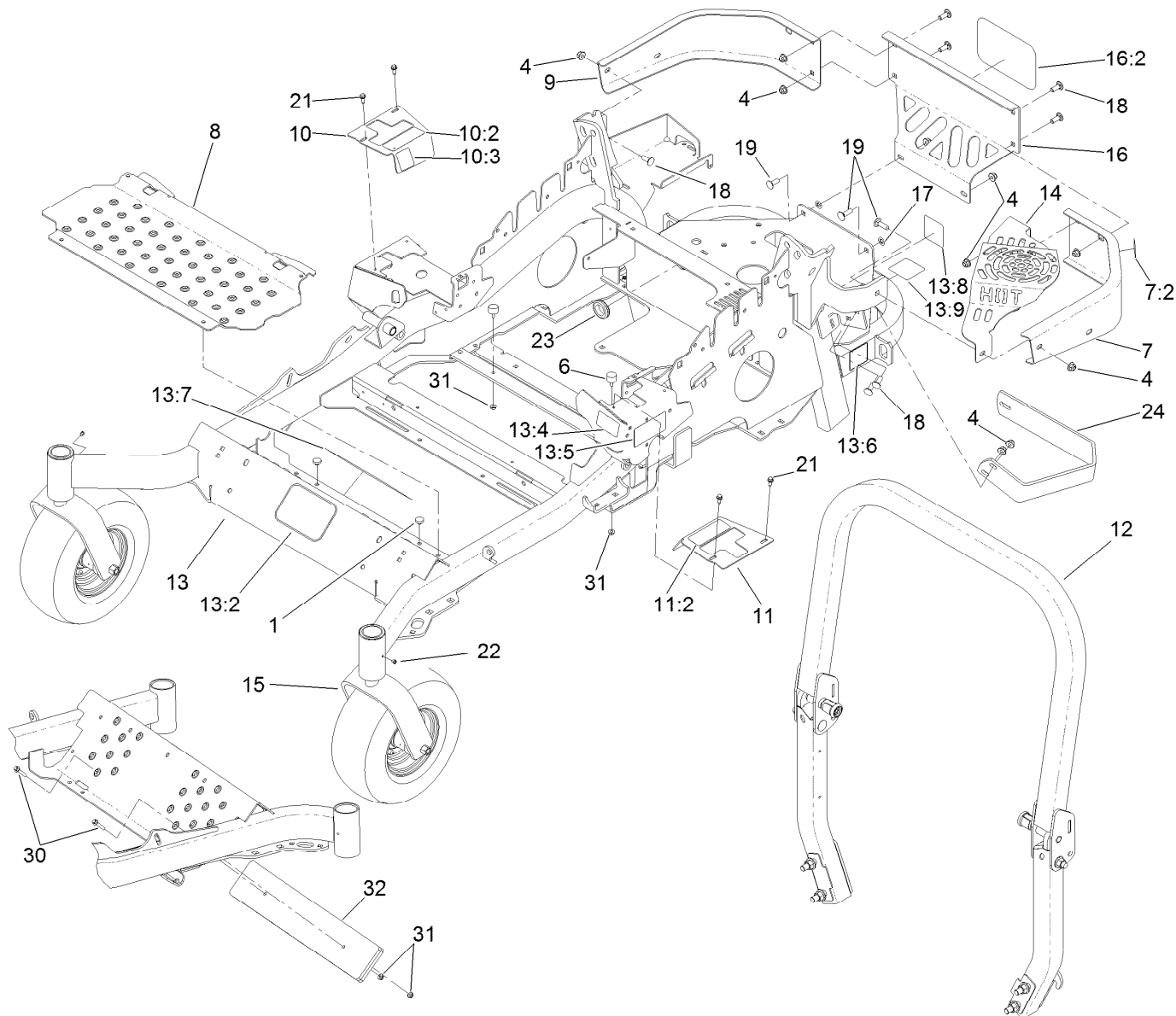

## Frame and Caster Wheel Assembly

Ref.	Part Number	Qty.	Description
1	1-513658	2	Bumper
4	104-8301	10	Nut-Flange, NI
6	116-6380	2	Bumper-Rubber (W/ Stud)
7	109-9869	1	Bumper-Rear, LH
7:2	103-2076	1	Decal-Caution
8	116-0024-01	1	Floorpan
9	116-0508-03	1	Bumper-Rear, RH
10	120-3280	1	Motion Control Cover, RH
10:2	109-7232	1	Decal-Motion Control
10:3	116-5944	1	Decal-Park Brake
11	120-3279	1	Motion Control Cover, LH
11:2	109-7232	1	Decal-Motion Control
12	116-0231	1	ROPS ASM
13	117-8581	1	Frame ASM
13:2	68-3640	1	Decal
13:4	116-1654	1	Decal-Fuel Fill
13:5	120-5891	2	Decal
13:6	116-0205	2	Decal-Belt Drive

Ref.	Part Number	Qty.	Description
13:7	116-3303	1	Decal-Slope
13:8	116-4858	1	Decal-Spark Arrester
13:9	117-1158	2	Decal-Bypass
14	120-7896-03	1	Guard-Muffler
15		2	Front Caster ASM ●
16	119-2691	1	Rear Guard ASM
16:2	67-7320	1	Decal
17	107-3154	2	Nut-Push
18	3231-22	7	Screw-CARR
19	3231-25	3	Bolt-CARR
21	32144-10	4	Screw-HWH
22	1-811010	2	Plug
23	120-3265	1	Grommet
24	119-2607-03	1	Guard-Muffler, Side
30	3234-21	2	Screw-HHF
31	104-7201	4	Nut-HF
32	121-4773-01	2	Weight

● Not serviced separately

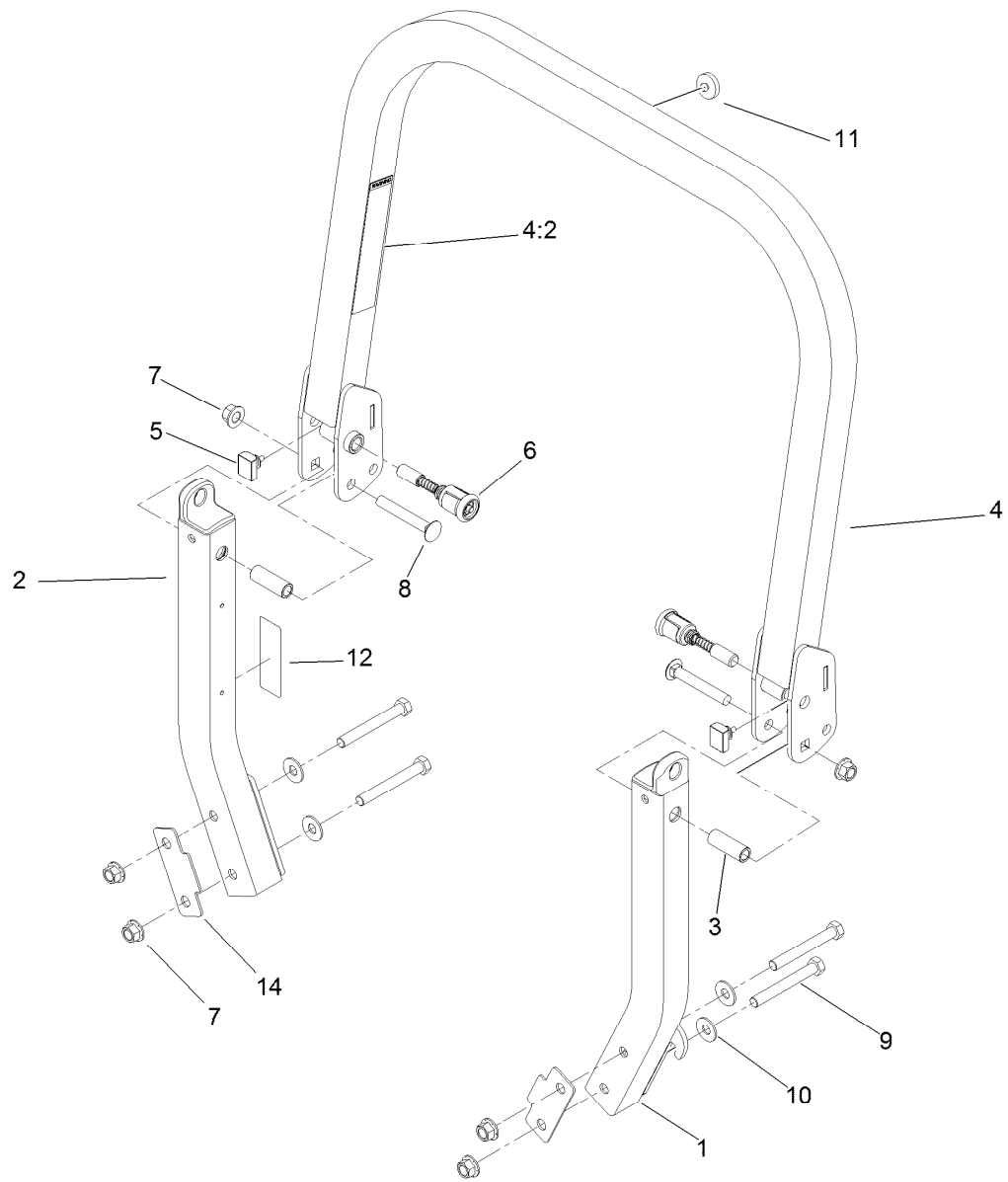

## Roll-Over Protection System Assembly No. 116-0231

Ref.	Part Number	Qty.	Description
1		1	LH ROPS Leg ASM ●
2		1	RH ROPS Leg ASM ●
3	109-6653	2	Spacer
4		1	Upper ROPS ASM ●
4:2	107-2102	1	Decal-Warning, Folding ROPS
5	109-5337	2	Bumper-ROPS
6	116-0104	2	Spring Pin ASM
7	99-5107	6	Nut-Lock
8	3233-10	2	Screw-CARR
9	325-17	4	Screw-HH
10	109-9505	4	Washer-Spring
11	109-9233	1	Bumper-Push-In, Rubber
12	116-0090	1	Decal-Caution
14	116-0960	2	Spacer

● Not serviced separately

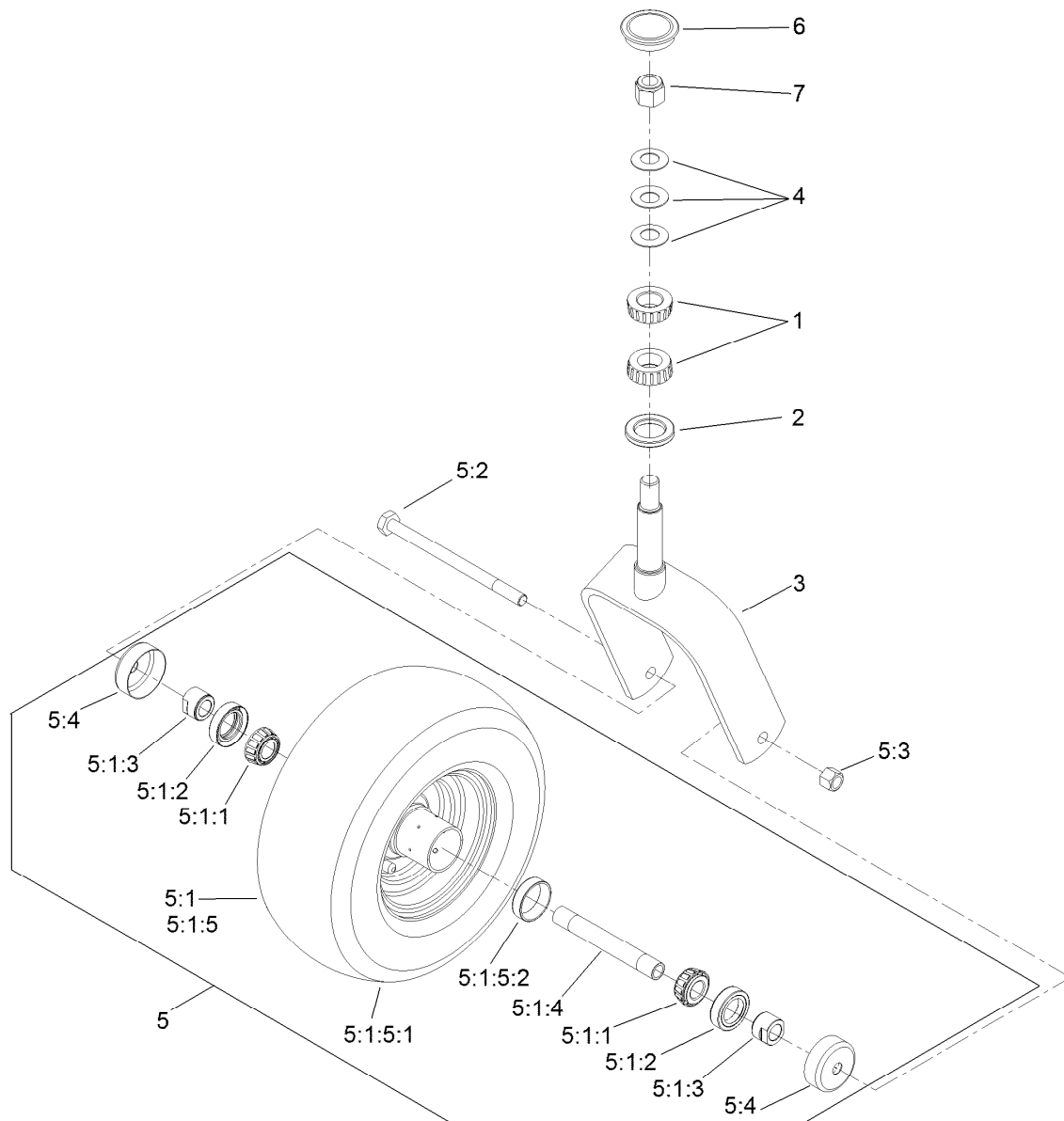

## Caster Fork and Wheel Assembly

Ref.	Part Number	Qty.	Description	Ref.	Part Number	Qty.	Description
1	1-543509	2	Bearing-Roller, Tapered	5:1:4	103-3155	1	Axle-Caster
2	1-543511	1	Seal-Grease	5:1:5		1	Wheel And Tire ASM ●
3	1-632511-01	1	Caster	5:1:5:1	116-1952	1	Tire
4	1-633508	3	Washer-Bellville	5:1:5:2	1-633584	2	Bearing-Cup
5	116-1949	1	Wheel And Tire ASM	5:2	325-42	1	Screw-HH
5:1		1	Tire And Wheel ASM ●	5:3	3296-23	1	Nut-Lock, NI
5:1:1	1-633585	2	Bearing-Cone, Taper	5:4	103-2768	2	Guard-Seal
5:1:2	103-0063	2	Seal-Caster	6	103-4882	1	Cap-Grease
5:1:3	103-3051	2	Spacer-Nut	7	3296-51	1	Nut-Lock, NI

● Not serviced separately

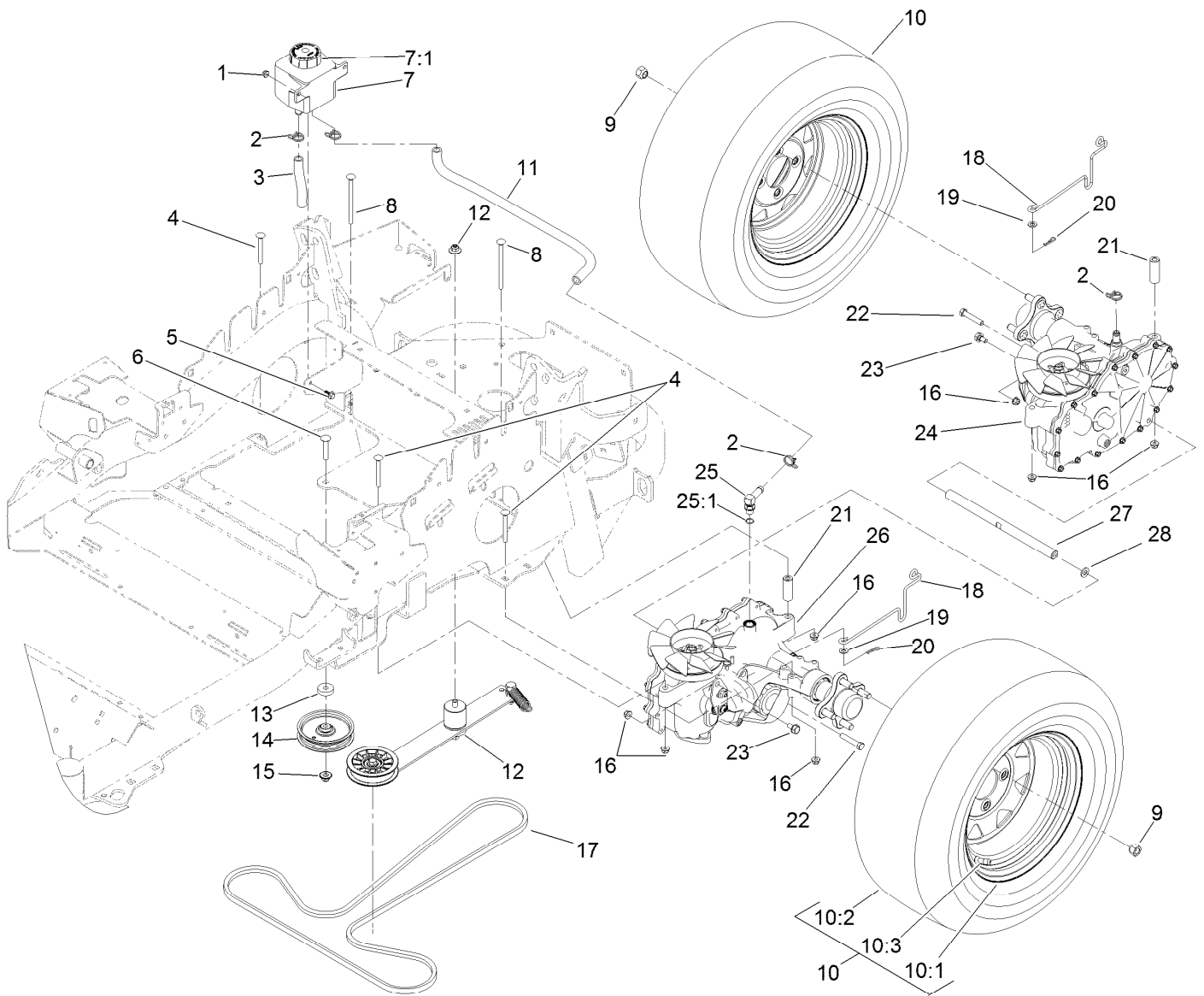

## Hydro Drive System Assembly

Ref.	Part Number	Qty.	Description	Ref.	Part Number	Qty.	Description
1	104-7201	2	Nut-HF	14	93-1622	1	Pulley-Idler
2	117-1193	4	Clamp-Hose	15	109-6658	1	Nut-Flange, NI
3	119-2642	1	Hose-HYD	16	104-8300	10	Nut-Flange, NI
4	3230-9	6	Screw-CARR	17	114860	1	Belt-V
5	99-6810	2	Screw-HH	18	115-4990	2	Rod-Bypass
6	117-9971	1	Bolt-Carriage	19	3256-23	2	Washer-Flat
7	109-2250	1	Vent-Tank, Hydro	20	1-806003	2	Pin-Cotter, Hair
7:1	109-3320	1	Cap-Reservoir, HYD	21	109-3652	2	Spacer-Hydro
8	3230-30	2	Screw-CARR	22	94-7972	2	Screw-HH W/Loctite
9	242-50	8	Nut-Lug	23	37-8771	2	Bolt-Shoulder
10	119-2692	2	Wheel And Tire ASM	24	120-7861	1	RH Transaxle ASM
10:1	120-3274	1	Wheel	25	109-6449	1	Fitting-Elbow, 90
10:2	120-3271	1	Tire	25:1	237-42	1	O-Ring
10:3	232-27	1	Stem-Valve	26	120-7860	1	LH Transaxle ASM
11	119-2689	1	Hose-HYD	27	117-8585	1	Shaft-Cross, Hydro
12	119-2689	1	Hose-Idler Arm ASM ●	28	3256-24	1	Washer-Flat
13	105-7788	1	Spacer				

● Not serviced separately

# RH Transaxle Assembly No. 120-7861

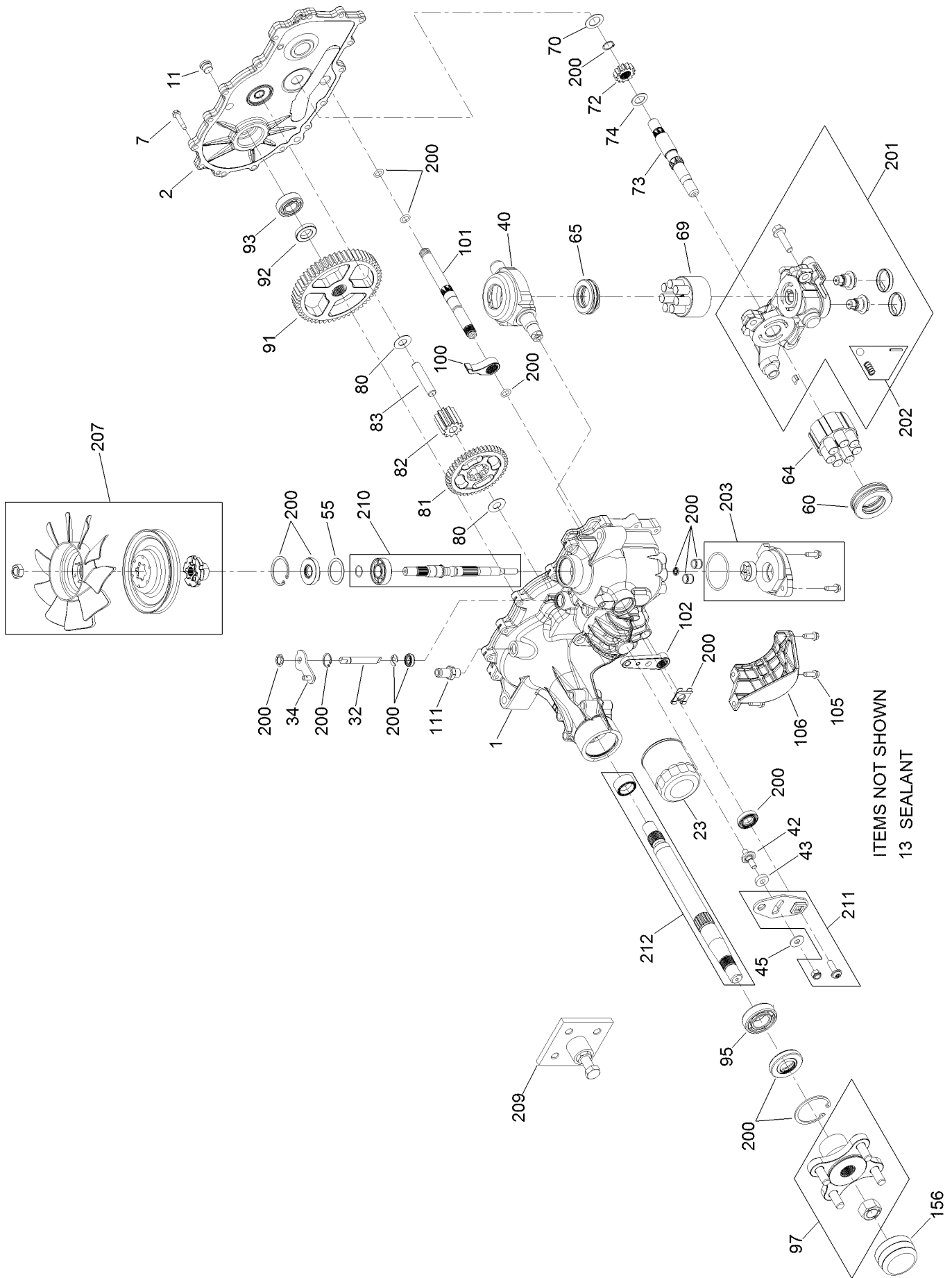

## RH Transaxle Assembly No. 120-7861 (continued)

<i>Ref.</i>	<i>Part Number</i>	<i>Qty.</i>	<i>Description</i>	<i>Ref.</i>	<i>Part Number</i>	<i>Qty.</i>	<i>Description</i>
1	114-1676	1	Main Housing Kit	83	104-5329	1	Pin-Jackshaft
2	117-5358	1	Housing Side Kit	91	114-1694	1	Gear-54T
7	117-5359	16	Screw-HHF	92	120-7975	1	Spacer
11	104-2189	1	Plug-Thread, Straight	93	114-1696	1	Bearing-Ball
13	104-2147	1	Sealant ●	95	120-7976	1	Bearing-Ball
23	109-3321	1	Element-Oil Filter, HYD	97	109-5939	1	Hub Kit
32	114-1685	1	Rod-Bypass	100	114-1697	1	Pawl-Brake
34	107-2490	1	Arm-Bypass	101	120-7977	1	Brake Shaft Kit
40	104-5304	1	Swashplate-Trunnion	102	125-0021	1	Handle-Brake
42	104-2116	1	Stud	105	104-2120	3	Screw
43	112-9853	1	Puck-Friction	106	120-7981	1	Guard-Filter, RH
45	114-8491	1	Washer	111	109-3278	1	Adapter-Straight
55	104-5308	1	Spacer	156	115-5057	1	Cover-Nut, Axle
60	109-2865	1	Bearing-Thrust	200	109-3537	1	Complete Seal Kit
64	114-1689	1	Motor Cylinder Block Kit	201	120-7982	1	RH Center Section Charge Kit
65	94-6922	1	Bearing-Thrust				
69	110-8561	1	Pump Block ASM	202	114-8464	1	Charge Relief Kit
70	104-5339	1	Washer-Flat	203	114-8465	1	Charge Kit
72	120-7972	1	Gear-13T	207	121-2988	1	Fan And Pulley Kit
73	114-1691	1	Shaft-Motor	209	114-8467	1	Hub-Puller, 4 Bolt
74	104-5360	1	Washer	210	117-5361	1	Shaft Input Kit
80	94-1933	2	Washer	211	117-5362	1	Arm Control Kit
81	120-7973	1	Gear-46T	212	114-8470	1	Axle Shaft Kit
82	120-7974	1	Gear-11T				

● Not illustrated



## LH Transaxle Assembly No. 120-7860 (continued)

<i>Ref.</i>	<i>Part Number</i>	<i>Qty.</i>	<i>Description</i>	<i>Ref.</i>	<i>Part Number</i>	<i>Qty.</i>	<i>Description</i>
1	114-8471	1	Main Housing Kit	82	120-7974	1	Gear-11T
2	114-8472	1	Side Cover Kit	83	104-5329	1	Pin-Jackshaft
7	117-5359	16	Screw-HHF	91	114-1694	1	Gear-54T
11	104-2189	1	Plug-Thread, Straight	92	120-7975	1	Spacer
13	104-2147	1	Sealant	93	114-1696	1	Bearing-Ball
23	109-3321	1	Element-Oil Filter, HYD	95	120-7976	1	Bearing-Ball
32	114-1685	1	Rod-Bypass	97	109-5939	1	Hub Kit
34	107-2490	1	Arm-Bypass	100	114-1697	1	Pawl-Brake
40	104-5304	1	Swashplate-Trunnion	101	114-1698	1	Shaft-Inboard Brake
42	104-2116	1	Stud	102	125-0021	1	Handle-Brake
43	112-9853	1	Puck-Friction	105	104-2120	3	Screw
45	114-8491	1	Washer	106	120-7979	1	Guard-Filter, LH
55	104-5308	1	Spacer	156	115-5057	1	Cover-Nut, Axle
60	109-2865	1	Bearing-Thrust	200	109-3537	1	Complete Seal Kit
64	114-1689	1	Motor Cylinder Block Kit	201	120-7980	1	LH Center Section Charge Kit
65	94-6922	1	Bearing-Thrust	202	114-8464	1	Charge Relief Kit
69	110-8561	1	Pump Block ASM	203	114-8465	1	Charge Kit
70	104-5339	1	Washer-Flat	207	121-2988	1	Fan And Pulley Kit
72	120-7972	1	Gear-13T	209	114-8467	1	Hub-Puller, 4 Bolt
73	114-1691	1	Shaft-Motor	210	117-5361	1	Shaft Input Kit
74	104-5360	1	Washer	211	117-5362	1	Arm Control Kit
80	94-1933	2	Washer	212	114-8470	1	Axle Shaft Kit
81	120-7973	1	Gear-46T				

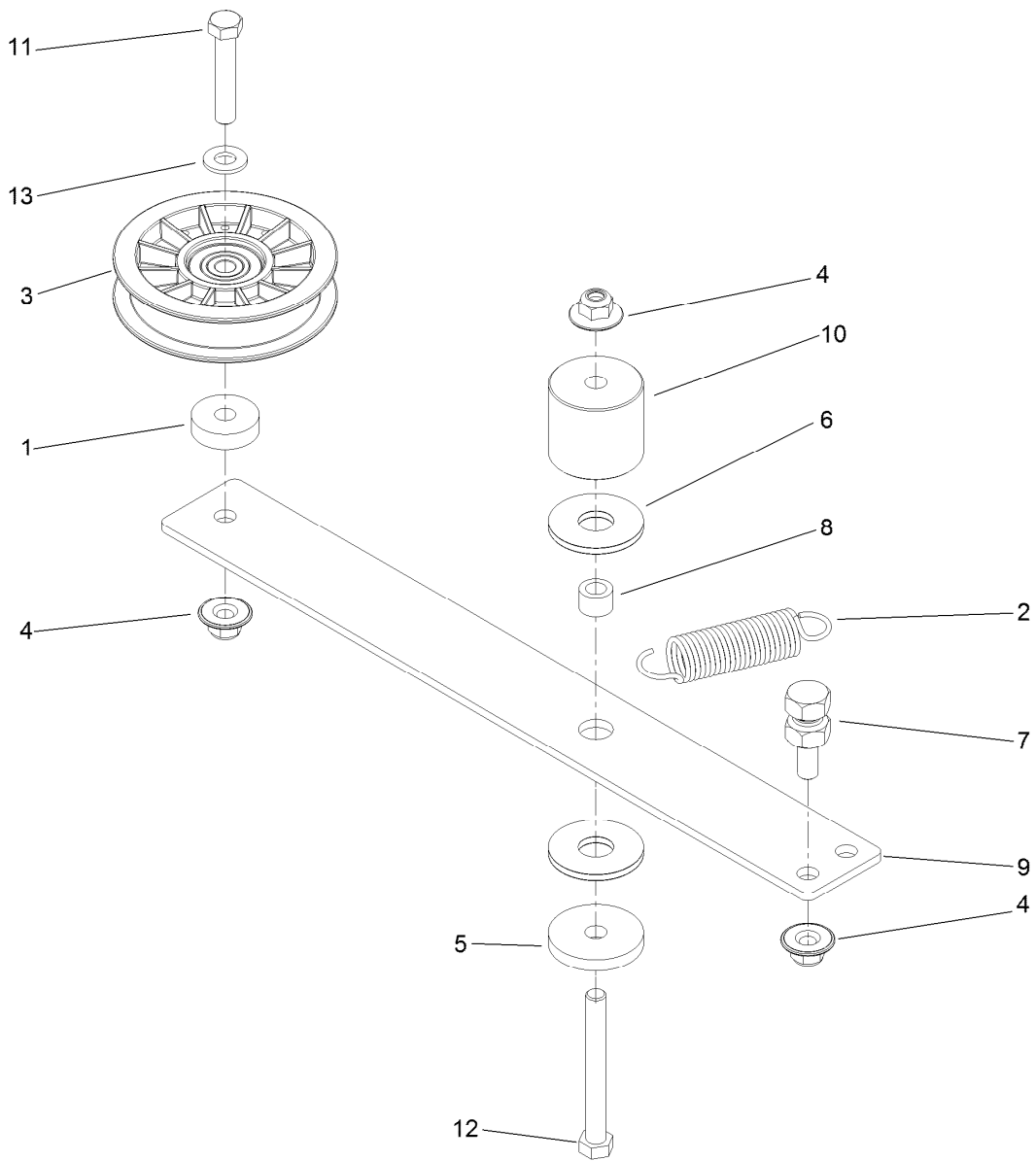

## Hydro Idler Arm Assembly

<i>Ref.</i>	<i>Part Number</i>	<i>Qty.</i>	<i>Description</i>
1	105-7788	1	Spacer
2	108-4056	1	Spring-Extension
3	109-3397	1	Pulley-Idler, Flat
4	109-6658	3	Nut-Flange, NI
5	110-9981	1	Washer-Plain
6	114-0463	2	Washer-Friction, Composite
7	114-5866	1	Anchor-Spring, Short
8	115-4986	1	Spacer
9	119-9914	1	Arm-Idler, Hydro
10	119-2657	1	Spacer-Plain
11	323-10	1	Screw-HH
12	323-20	1	Screw-HH
13	3256-24	1	Washer-Flat

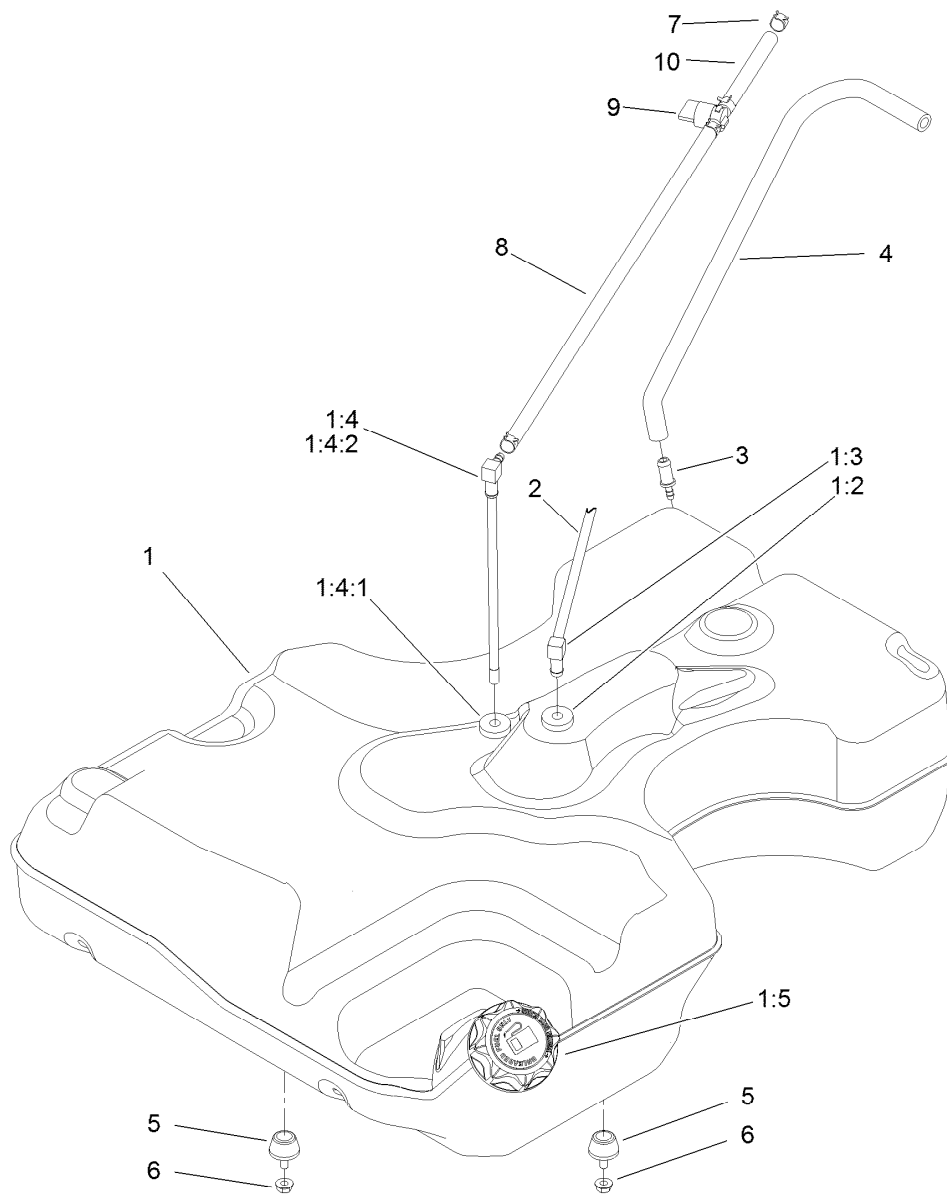

## Fuel Tank and Hose Assembly

Ref.	Part Number	Qty.	Description	Ref.	Part Number	Qty.	Description
1	120-7879	1	Fuel Tank ASM	2	119-6074	1	Hose-Fuel
1:2	46-6560	2	Bushing	3	98-2952	1	Fitting-Straight
1:3	116-2288	1	Fitting-90 Elbow, 0.043 Orifice	4	119-8562	1	Hose-Fuel
1:4	120-7871	1	Fuel Line Kit	5	109-2365	2	Rubber Bumper ASM
1:4:1	46-6560	1	Bushing	6	32128-33	2	Nut-HF
1:4:2	119-8584	1	Fitting-Fuel (W/Line And Screen)	7	2412-98	4	Clamp-Hose
1:5	116-1704	1	Cap-Fuel, Ratcheting	8	110-5701	1	Hose-Fuel
				9	1-603770	1	Valve-Fuel
				10	109-0650	1	Hose-Fuel

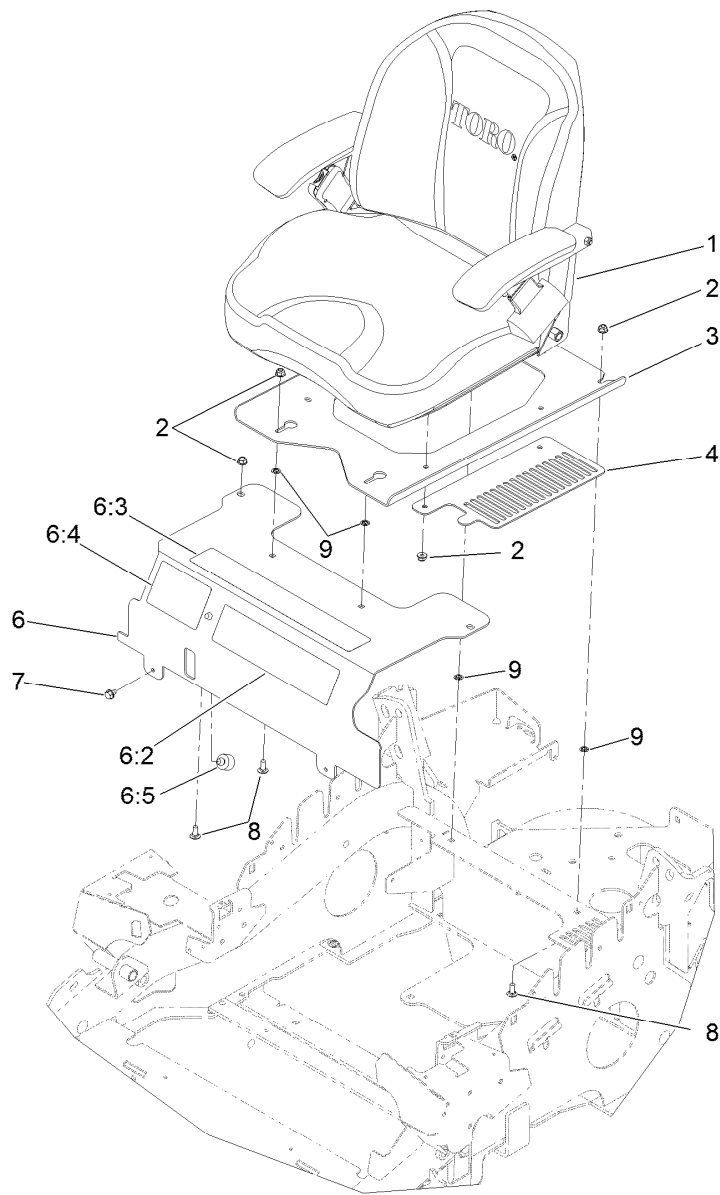

## Seat Mounting Assembly

<i>Ref.</i>	<i>Part Number</i>	<i>Qty.</i>	<i>Description</i>
1	120-7886	1	Seat
2	104-8300	10	Nut-Flange, NI
3	117-8615-03	1	Plate-Mount, Seat
4	117-8618-03	2	Plate-Cover, Fan
6	119-2597	1	Seat Mount Panel ASM
6:2	114-5878	1	Decal
6:3	109-7069	1	Decal-Console
6:4	116-0211	1	Decal-Service Aid
6:5	120-7893	1	Bumper-Grommet
7	9266934	2	Screw
8	3230-23	6	Screw-CARR
9	117-2749	4	Nut-Push

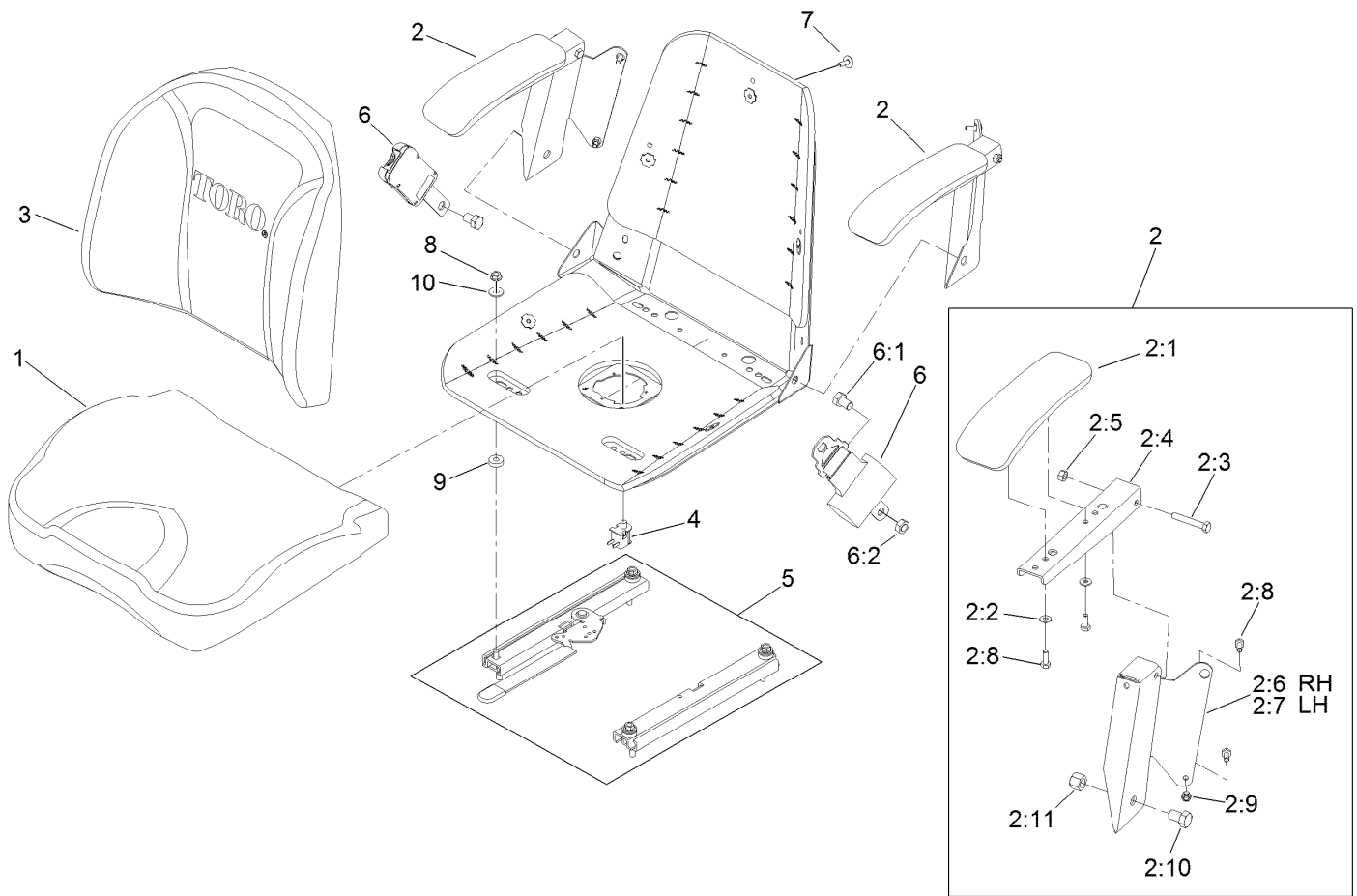

## Seat Assembly No. 120-7886

Ref.	Part Number	Qty.	Description
1	121-4751	1	Cushion-Seat, Bottom
2	110-5719	1	Armrest Kit
2:1	110-4163	2	Cushion-Rest, Arm
2:2	3256-22	4	Washer-Flat
2:3	322-10	2	Screw-HH
2:4	105-3623	2	Channel-Armrest
2:5	32153-3	2	Nut-Hex, Side Deform
2:6	105-3621	1	Bracket-Armrest, RH
2:7	105-3622	1	Bracket-Armrest, LH
2:8	321-30	8	Screw-HH
2:9	3296-42	4	Nut-Lock, NI
2:10	325-2	2	Screw-HH

Ref.	Part Number	Qty.	Description
2:11	3296-23	2	Nut-Lock, NI
3	121-4752	1	Cushion-Seat, Back
4	82-2190	1	Switch-Bail
5	121-4754	1	Track-Seat
6	116-2981	1	Seat Belt Kit
6:1	325-2	2	Screw-HH
6:2	3296-23	2	Nut-Lock, NI
7	103-8383	7	Bolt-Seat
8	32128-20	4	Nut-HF
9	26-4840	8	Spacer-Pin, Mounting
10	3256-3	6	Washer-Flat

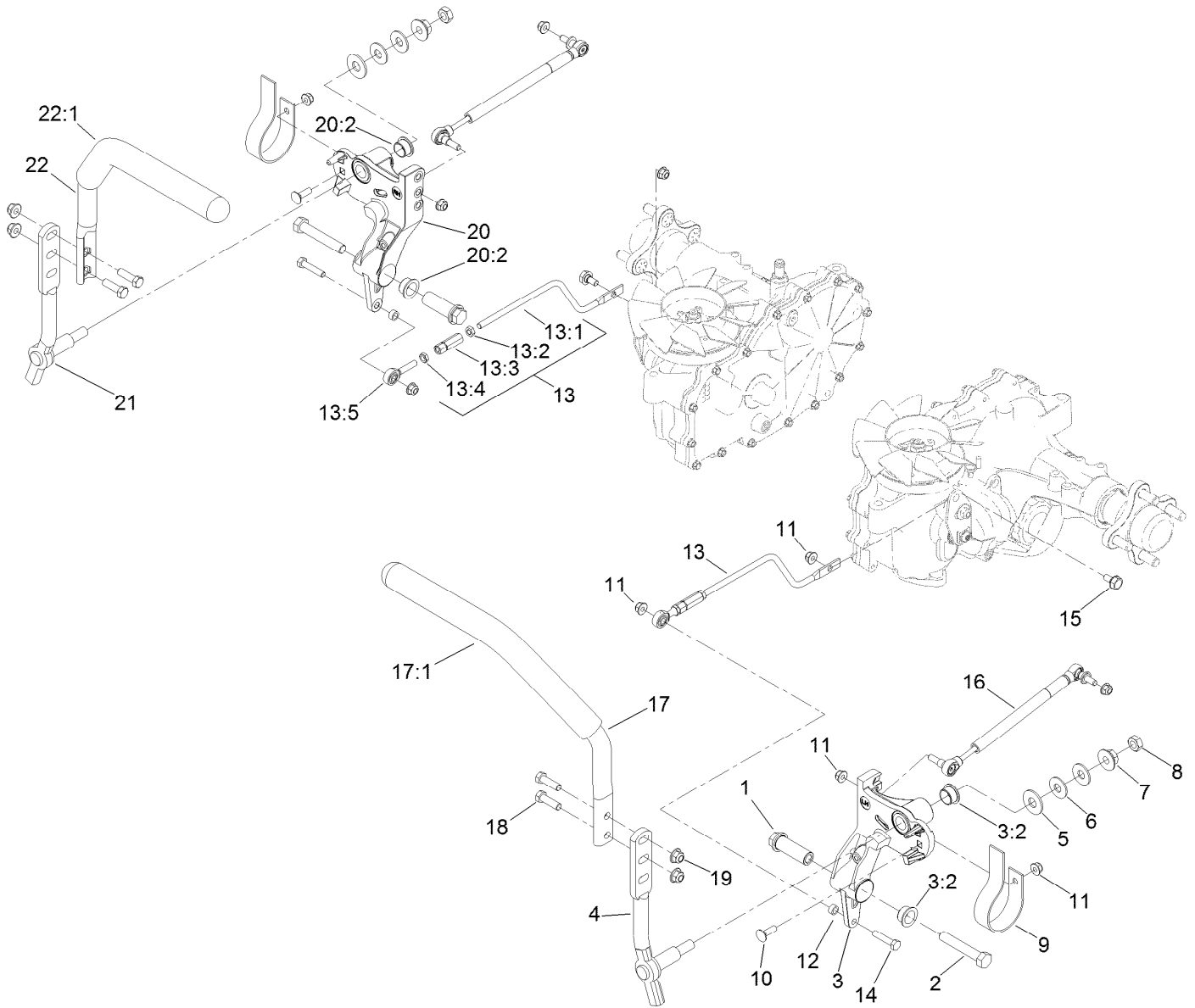

## Motion Control Assembly

Ref.	Part Number	Qty.	Description	Ref.	Part Number	Qty.	Description
1	109-5891	2	Hub-Threaded	13:3	109-3728	1	Nut-Rod Adjustment
2	325-12	2	Screw-HH	13:4	3220-20	1	Nut-Jam
3	116-0881	1	LH Motion Control And Bushing ASM	13:5	2411-53	1	Bearing-Rod End, LH
3:2	109-8054	4	Bushing-Flange	14	322-7	2	Screw-HH
4	116-0040	1	Lever-Control Motion, LH	15	37-8771	2	Bolt-Shoulder
5	3256-6	2	Washer-Flat	16	116-0027	2	Damper-Control, Motion
6	109-9505	4	Washer-Spring	17	109-6590	1	LH Steering Handle ASM
7	32128-56	2	Nut-HF	17:1	109-5668	1	Grip-Control, Lever
8	3218-5	2	Nut-Jam	18	323-7	4	Screw-HH
9	109-5575	2	Spring-Leaf	19	104-8301	4	Nut-Flange, NI
10	3230-2	2	Bolt-CARR	20	116-0880	1	RH Motion Control And Bushing ASM
11	104-8300	10	Nut-Flange, NI	20:2	109-8054	4	Bushing-Flange
12	92-6998	2	Spacer-Yoke, Right	21	116-0039	1	Lever-Control Motion, RH
13	119-2605	2	Hydro Control Rod ASM	22	109-6589	1	RH Steering Handle ASM
13:1	119-2606	1	Rod-Control, Hydro	22:1	109-5668	1	Grip-Control, Lever
13:2	3220-2	1	Nut-Jam				

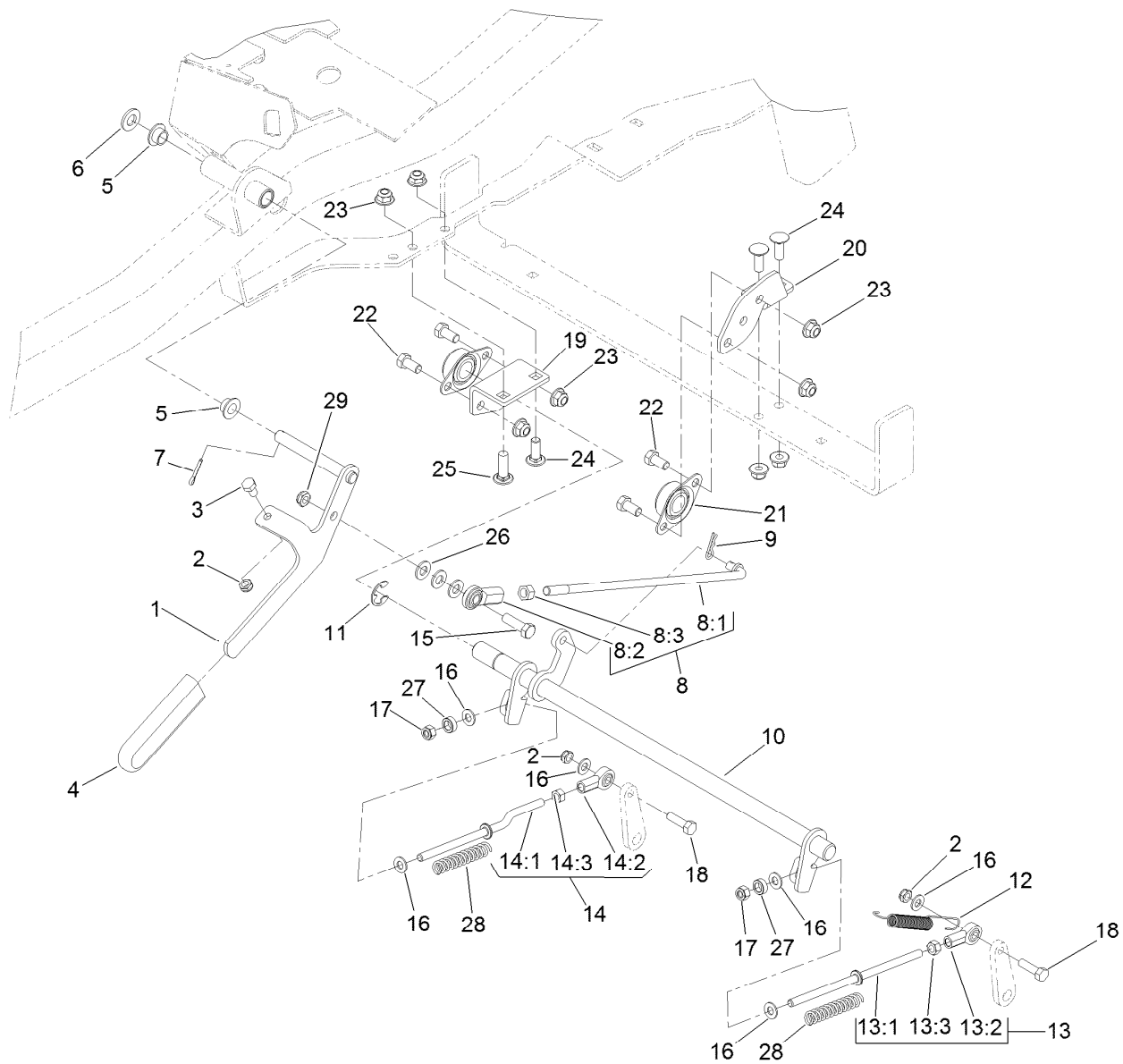

## Parking Brake Assembly

Ref.	Part Number	Qty.	Description	Ref.	Part Number	Qty.	Description
1	121-4766-03	1	Brake Handle ASM	14	121-4806	1	RH Brake Rod ASM
2	3296-47	3	Nut-Lock, NI	14:1	121-4770	1	Rod-Brake
3	322-1	1	Screw-HH	14:2	1-543017	1	Balljoint-RH
4	1-633268	1	Grip-Lever	14:3	3219-2	1	Nut-Hex
5	1-513140	2	Bearing-Control	15	323-7	1	Screw-HH
6	106-9888	1	Washer-Flat	16	3256-23	6	Washer-Flat
7	3272-10	1	Pin-Cotter	17	3296-4	2	Nut-Lock
8	121-4807	1	Brake Link ASM	18	322-16	2	Screw-HH
8:1	121-4795	1	Rod-Link, Brake	19	121-4761-01	1	Bracket-Shaft Mount, RH
8:2	103-0608	1	Joint-Ball, End	20	121-4793-01	1	Bracket-Shaft Mount, LH
8:3	3219-3	1	Nut-Hex	21	1-633102	2	Bearing-Flange, Side
9	3290-307	3	Pin-Hair	22	323-4	4	Screw-HH
10	121-4804-03	1	Brake Shaft ASM	23	104-8301	8	Nut-Flange, NI
11	32151-48	1	E-Ring	24	3231-22	3	Screw-CARR
12	110769	1	Spring-Extension	25	3231-28	1	Screw-CARR
13	121-4805	1	LH Brake Rod ASM	26	3256-24	3	Washer-Flat
13:1	121-4755	1	Rod-Brake	27	103-5677	2	Spacer
13:2	1-543017	1	Balljoint-RH	28	1-603807	2	Spring-Return, Neutral
13:3	3219-2	1	Nut-Hex	29	3296-59	1	Nut-Lock, NI

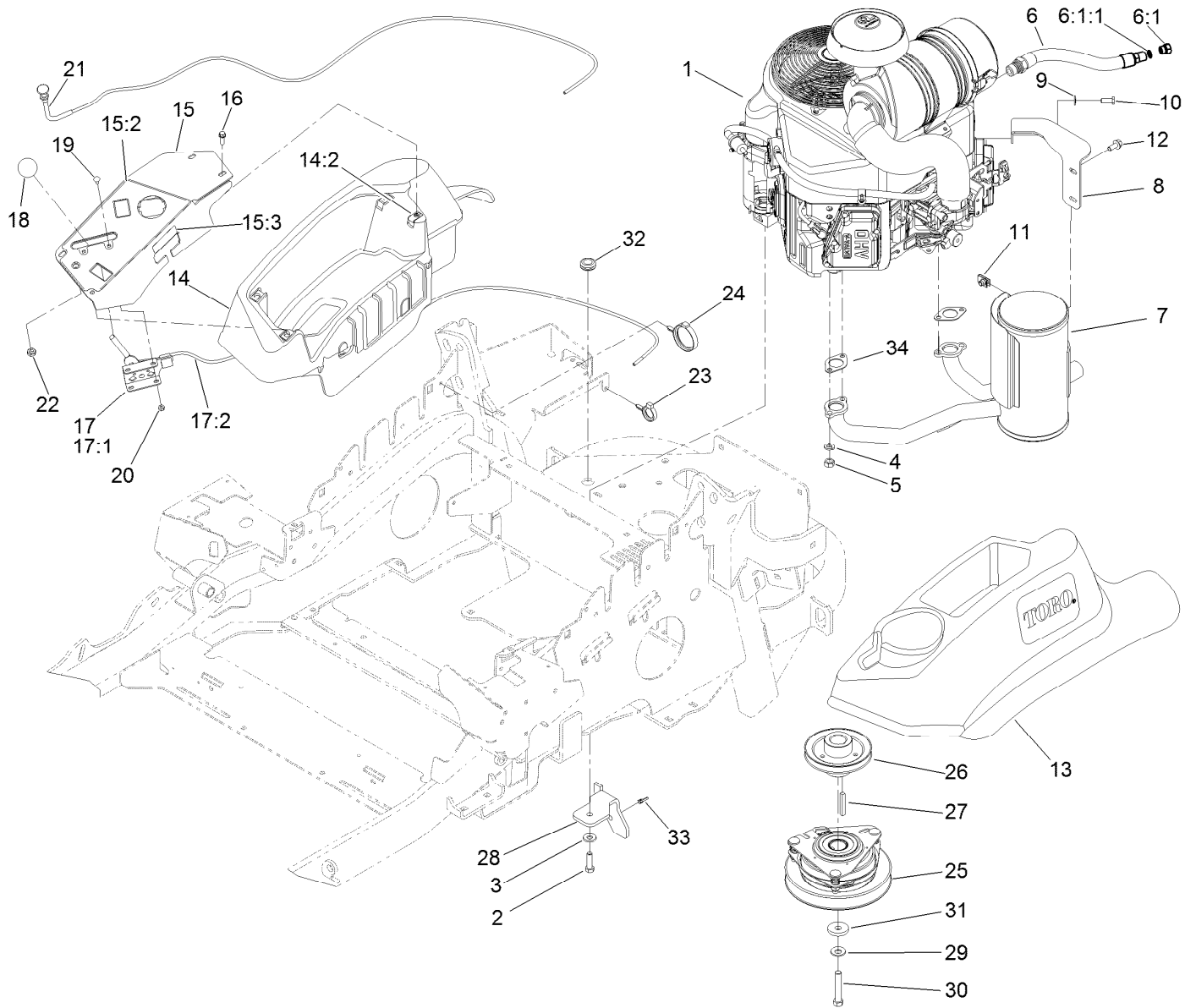

## Engine, Muffler and Control Panel Assembly

Ref.	Part Number	Qty.	Description	Ref.	Part Number	Qty.	Description
1		1	Engine-Kawasaki, Fx651V-S10-R ●■	15	119-2694	1	Control Panel ASM
2	323-7	4	Screw-HH	15:2	119-2501	1	Decal-Panel, Control
3	98-5975	4	Washer-Belleville	15:3	114-4466	1	Decal-Fuses
4	114-3550	4	Washer-Lock, Spring	16	32105-15	4	Screw
5	114-3549	4	Nut	17	110-5727	1	Throttle Control ASM
6	116-4924	1	Engine Oil Drain Hose ASM	17:1	112-2334	1	Lever-Throttle
6:1	353-508	1	Plug-HH	17:2	110-5728	1	Cable-Throttle
6:1:1	237-42	1	O-Ring	18	1-603175	1	Knob-Ball
7	119-2645	1	Muffler	19	1-807513	2	Bolt-CARR
8	119-2659	1	Bracket-Muffler	20	3296-2	2	Nut-Lock, NI
9	1-303334	1	Washer-Spring	21	115-2753	1	Choke Control ASM
10	33114-020	1	Screw-HH	22	3220-3	1	Nut-HJ
11	94-2413	2	U-Nut	23	105-1853	1	Clamp-Hose
12	3234-5	2	Screw-HHF	24	117-7817	1	Clamp-Harness
13	119-2602	1	Console-LH	25	119-2595	1	Clutch
14	119-2603	1	RH Console ASM	26	119-9915	1	Pulley-Engine
14:2	107069	4	Clip	27	608006	1	Key-Square
				28	119-2658-01	1	Bracket-Stop, Clutch

● Not serviced separately

■ Obtain parts from [www.kawpowerpc.com](http://www.kawpowerpc.com)

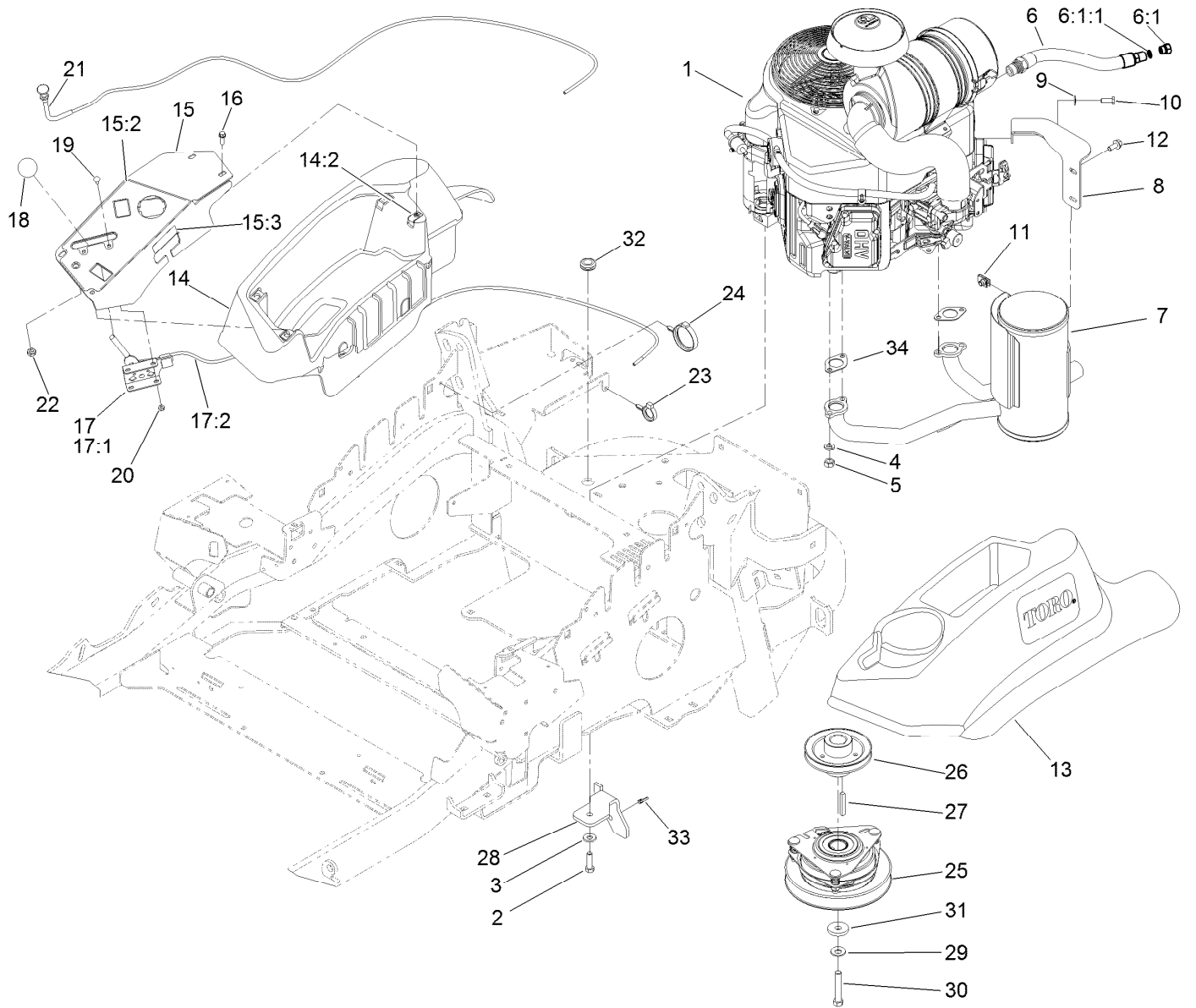

## Engine, Muffler and Control Panel Assembly (continued)

Ref.	Part Number	Qty.	Description
29	1-603610	1	Washer-Spring
30	3212-10	1	Screw-HH
31	107-4136	1	Washer

Ref.	Part Number	Qty.	Description
32	112-7069	1	Grommet
33	1-303287	1	Tie-Cable
34	1-653313	2	Gasket-Exhaust

● Not serviced separately

■ Obtain parts from [www.kawpowerpc.com](http://www.kawpowerpc.com)

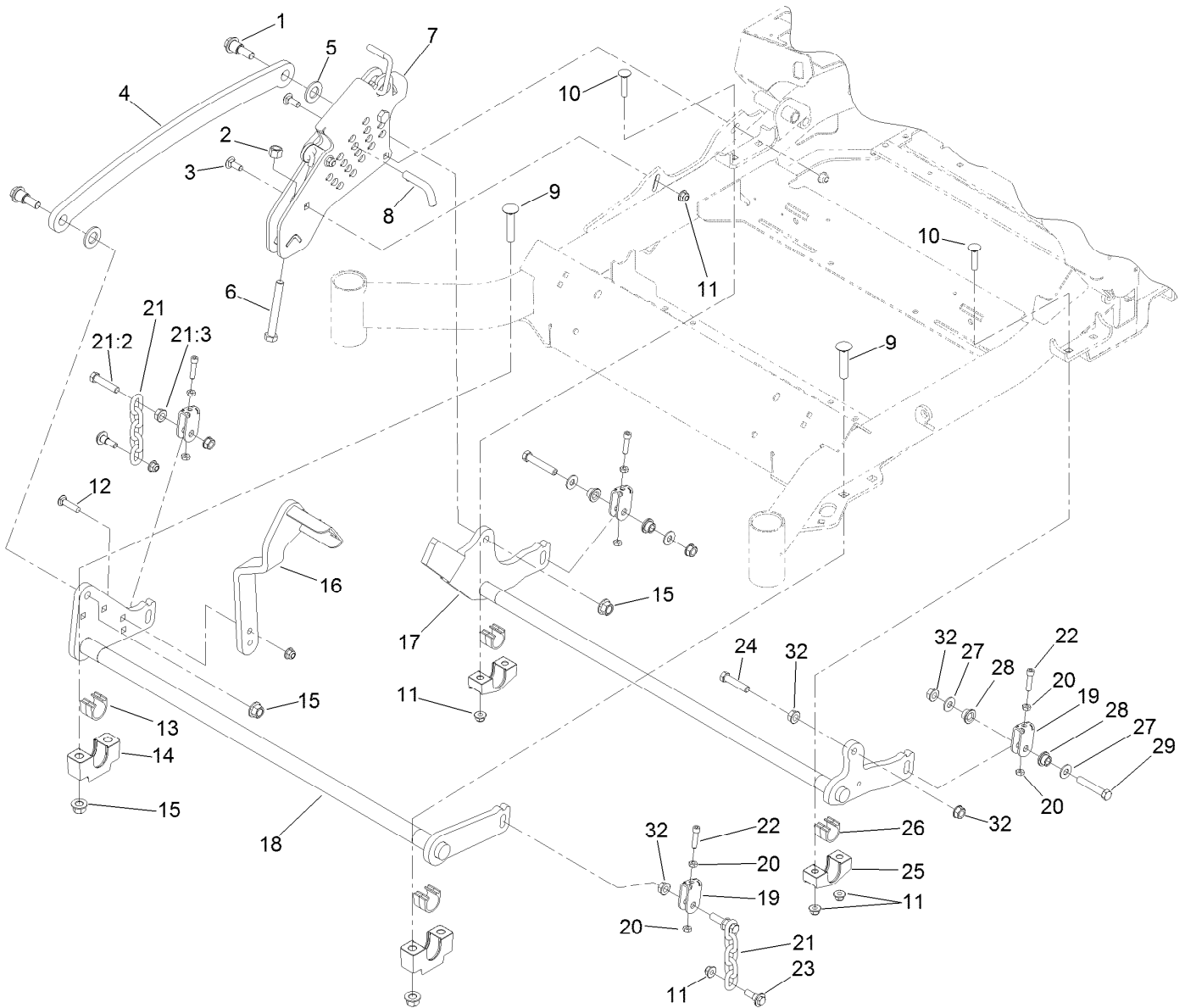

## Deck Lift Assembly

Ref.	Part Number	Qty.	Description	Ref.	Part Number	Qty.	Description
1	116-0780	2	Screw-HHF, Shoulder	17	116-0459-03	1	Lift-Deck, Rear
2	3296-23	1	Nut-Lock, NI	18	116-2217-03	1	Front Cross Shaft ASM
3	3231-2	2	Bolt-CARR	19	109-9066	4	Yoke-Adjust, Deck
4	116-0797-03	1	Link-Lift, Deck	20	3218-2	8	Nut-Jam
5	3256-28	2	Washer-Flat	21	116-0756	2	Deck Lift Chain ASM
6	116-0559	1	Bolt-TAP	21:2	109-9065	1	Screw-HH
7	120-2520	1	Height Of Cut ASM	21:3	32128-37	1	Nut-HF
8	116-5584	1	Pin-HOC	22	3274-18	4	Screw-HSH
9	116-1700	4	Bolt-CARR	23	109-9840	2	Screw-Shoulder, HHF
10	3231-5	4	Screw-CARR	24	109-9065	1	Screw-HH
11	104-8301	10	Nut-Flange, NI	25	116-0818-03	2	Support-Cross Shaft, Rear Bearing
12	3231-4	2	Screw-CARR	26	109-7173	2	Bearing-Cross Shaft, Rear
13	109-9410	2	Bearing-Cross Shaft, Front	27	3256-4	4	Washer-Flat
14	109-9409	2	Support-Cross Shaft, Front Bearing	28	116-2428	4	Bushing, Flanged
15	99-5107	6	Nut-Lock	29	324-10	2	Screw-HH
16	116-1919-01	1	Lever-Foot	32	32128-37	6	Nut-HF

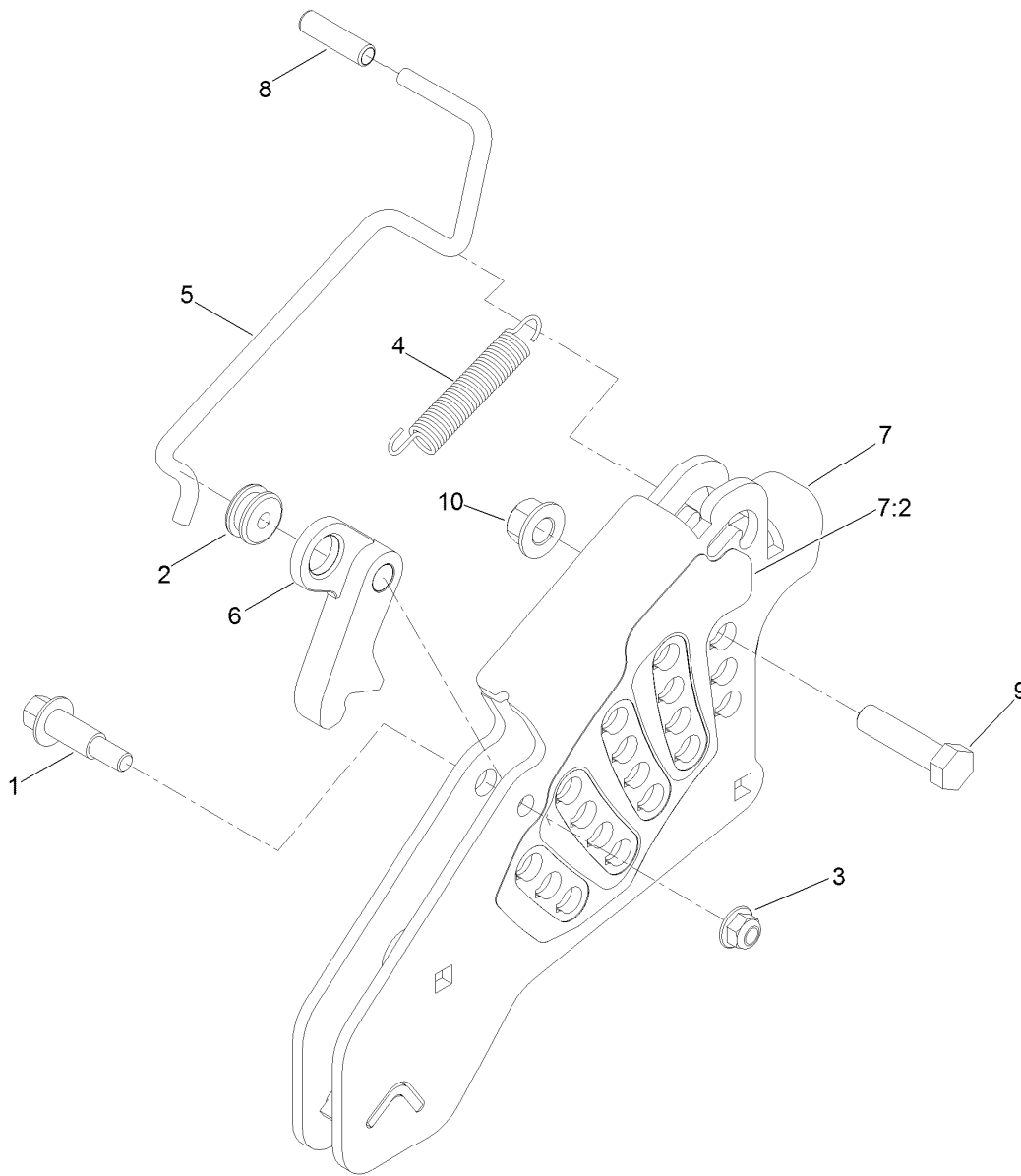

## Height-of-Cut Assembly No. 120-2520

<i>Ref.</i>	<i>Part Number</i>	<i>Qty.</i>	<i>Description</i>
1	62-1330	1	Bolt-Shoulder
2	109-7130	1	Grommet
3	104-8301	1	Nut-Flange, NI
4	109-7124	1	Spring-Extension
5	109-7128	1	Rod-Lock, Transport
6	116-0118	1	Pawl-Transport, HOC
7	120-2521	1	HOC Plate W/Decal ASM
7:2	120-2522	1	Decal-Height Of Cut
8	109-8250	1	Grip-Lever
9	325-8	1	Screw-HH
10	99-5107	1	Nut-Lock

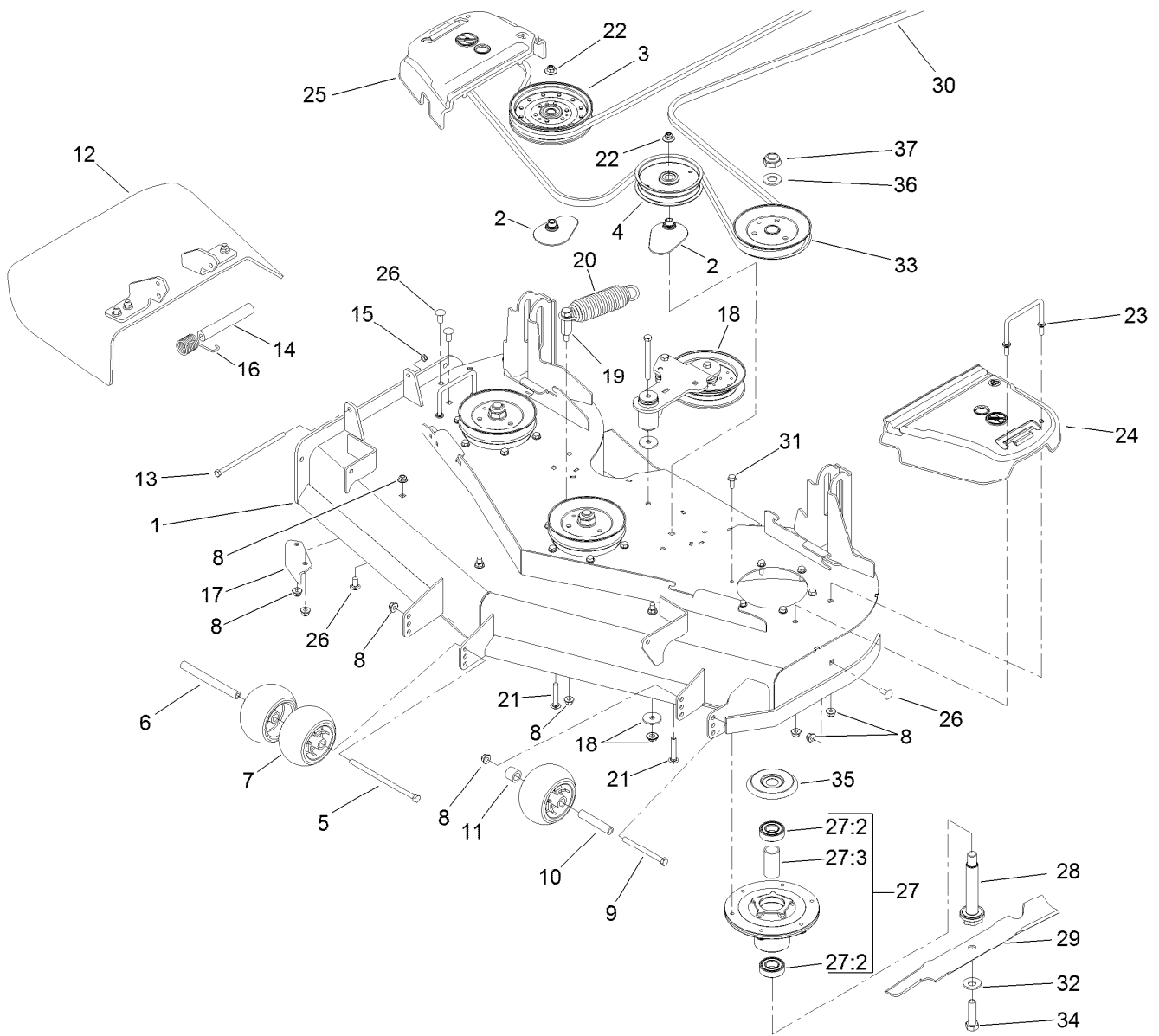

## Deck Assembly

Ref.	Part Number	Qty.	Description	Ref.	Part Number	Qty.	Description
1	120-2441	1	Deck Decal ASM	19	114-5867	1	Anchor-Spring, Tall
2	109-2872	2	Spacer-Pulley	20	116-0133	1	Extension-Spring
3	116-4670	1	Pulley-Idler, Flat	21	3231-40	2	Bolt-CARR, Short Neck
4	1-613098	1	Pulley-Idler	22	109-6658	2	Nut-Flange, NI
5	108-5388	1	Screw-HH	23	109-6982	2	Wireform-Cover
6	98-5967	1	Spacer-Wheel	24	109-6936	1	Cover-Belt, LH
7	1-603299	3	Roller-Scalp, Anti	25	109-6935	1	Cover-Belt, RH
8	104-8301	13	Nut-Flange, NI	26	3231-27	6	Screw-CARR
9	323-23	1	Screw-HH	27	120-5477	3	Spindle ASM
10	98-7912	1	Tube-Spanner	27:2	116-0720	2	Bearing-Ball
11	98-7913	1	Tube-Spacer	27:3	115-2641	1	Spacer-Bearing
12	120-2451	1	Deflector ASM	28	120-2505	3	Spindle-Shaft
13	322-50	1	Screw-HH	29	117-7277-03	3	Blade-Hi Flo, 16.50In
14	105-4622	1	Spacer	30	120-2409	1	Belt-V
15	3296-47	1	Nut-Lock, NI	31	32144-41	18	Screw-Taptite
16	108-4052	1	Spring-Torsion	32	22-8520	3	Washer-Belleville
17	107-8541-01	1	Baffle-Discharge	33	120-7854	3	Pulley-B Section
18		1	Idler Arm ASM ●	34	51-4060	3	Screw-Blade

● Not serviced separately

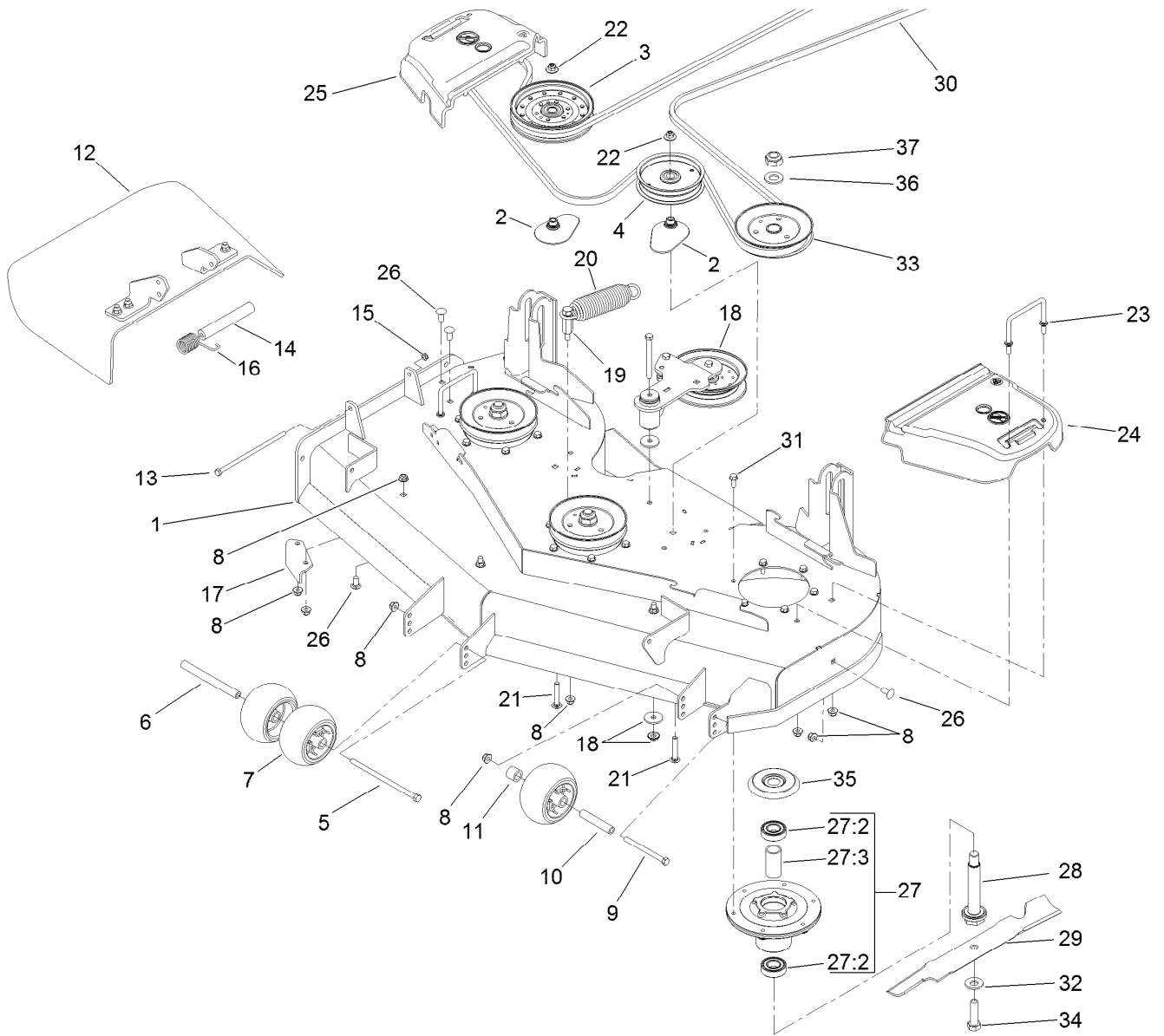

## Deck Assembly (continued)

Ref.	Part Number	Qty.	Description	Ref.	Part Number	Qty.	Description
35	117-7210	3	Shield-Bearing	36	92-5836	3	Washer
				37	3296-67	3	Nut-Lock, NI

● Not serviced separately

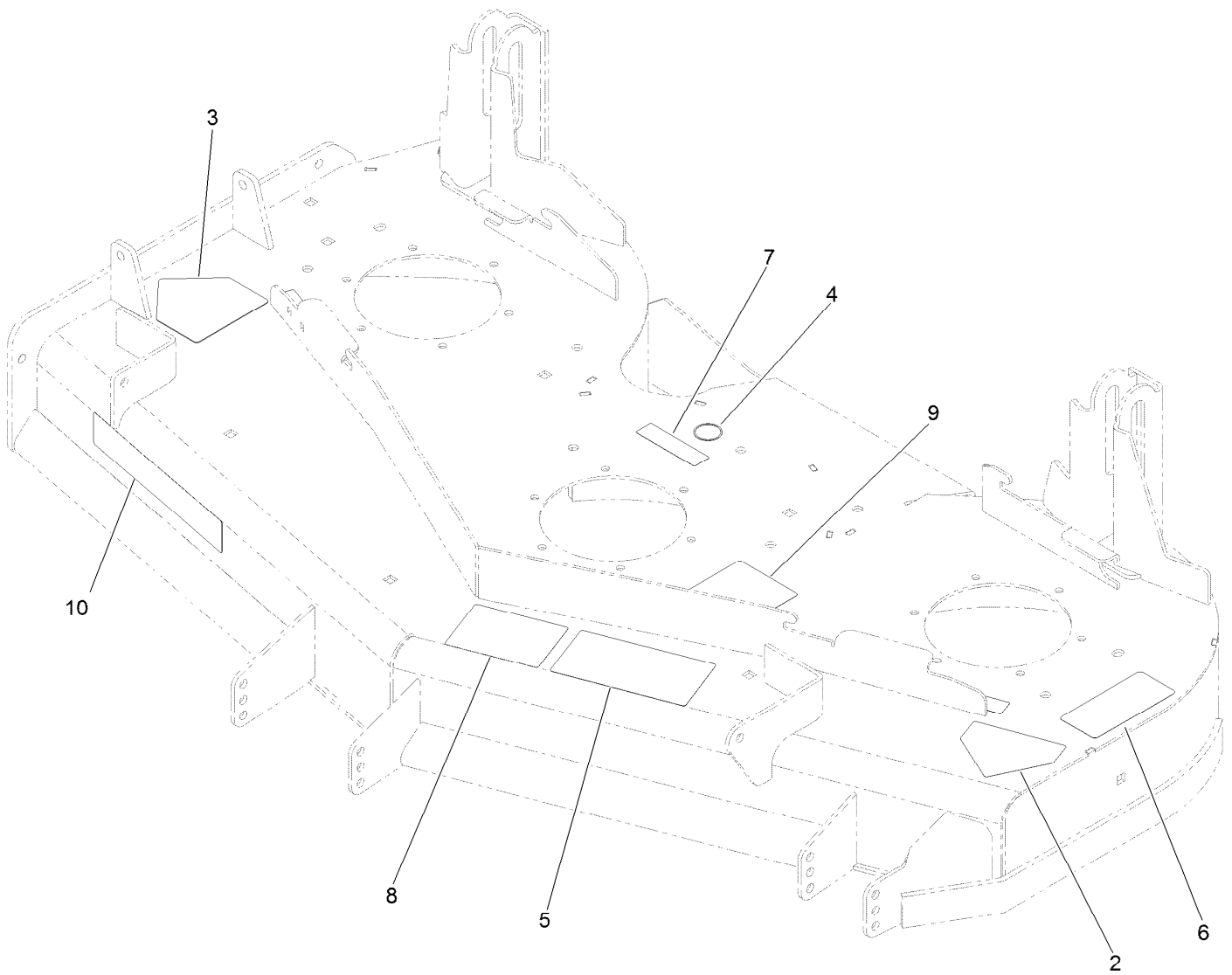

## Deck Decal Assembly No. 120-2441

<i>Ref.</i>	<i>Part Number</i>	<i>Qty.</i>	<i>Description</i>
2	1-403005	1	Decal-Danger
3	54-9220	1	Decal-Danger
4	58-6520	1	Decal-Grease
5	66-1340	1	Decal-Danger, Thrown Object
6	68-8340	1	Decal-Torque
7	98-5954	3	Decal-Cover, Missing
8	112-3858	1	Decal-Anti Scalp
9	117-8639	1	Decal-Routing, Deck Belt
10	121-3204	1	Decal

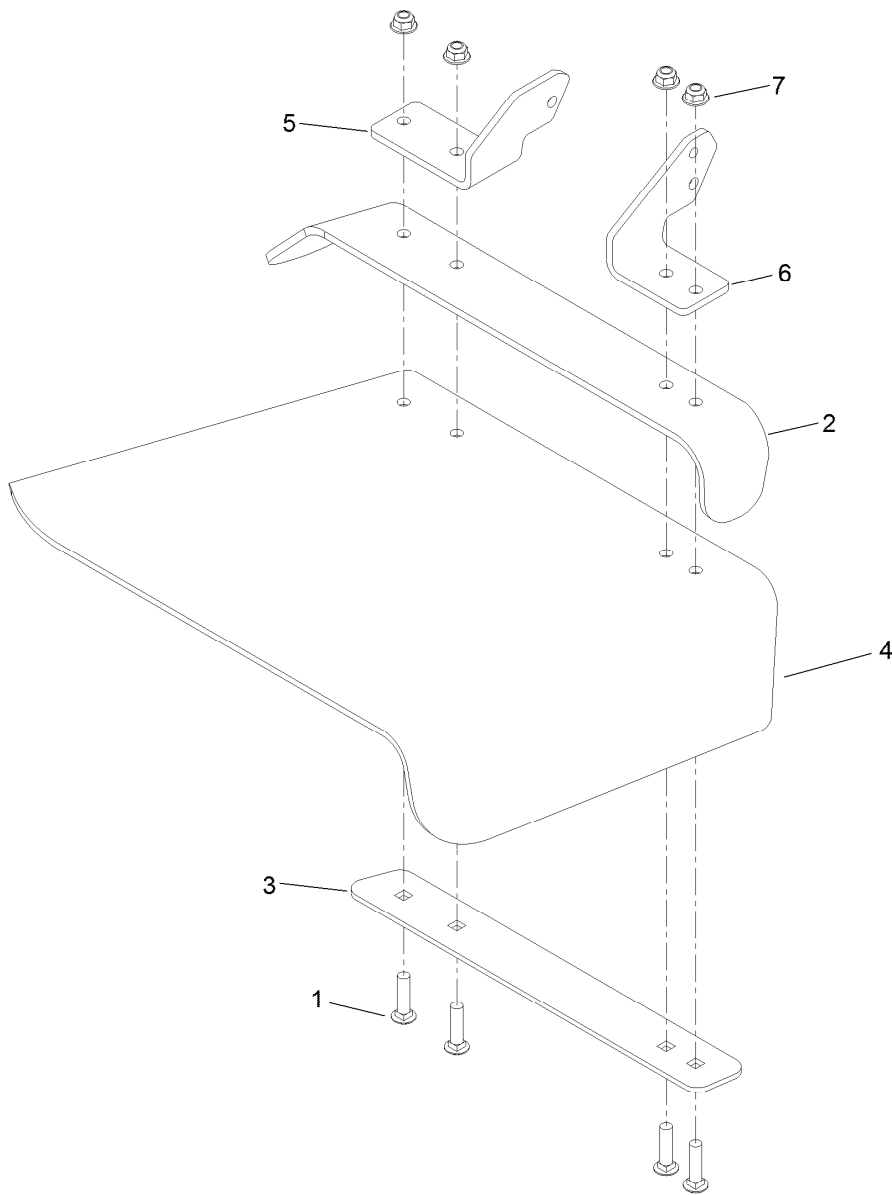

## Deflector Assembly No. 120-2451

<i>Ref.</i>	<i>Part Number</i>	<i>Qty.</i>	<i>Description</i>
1	3231-4	4	Screw-CARR
2	106-3246-01	1	Deflector
3	106-3248-03	1	Strap-Discharge
4	110-0759	1	Deflector-Rubber
5	108-4059-01	1	Plate-Hinge, Rear
6	106-3253-01	1	Plate-Hinge, Front
7	104-8301	4	Nut-Flange, NI

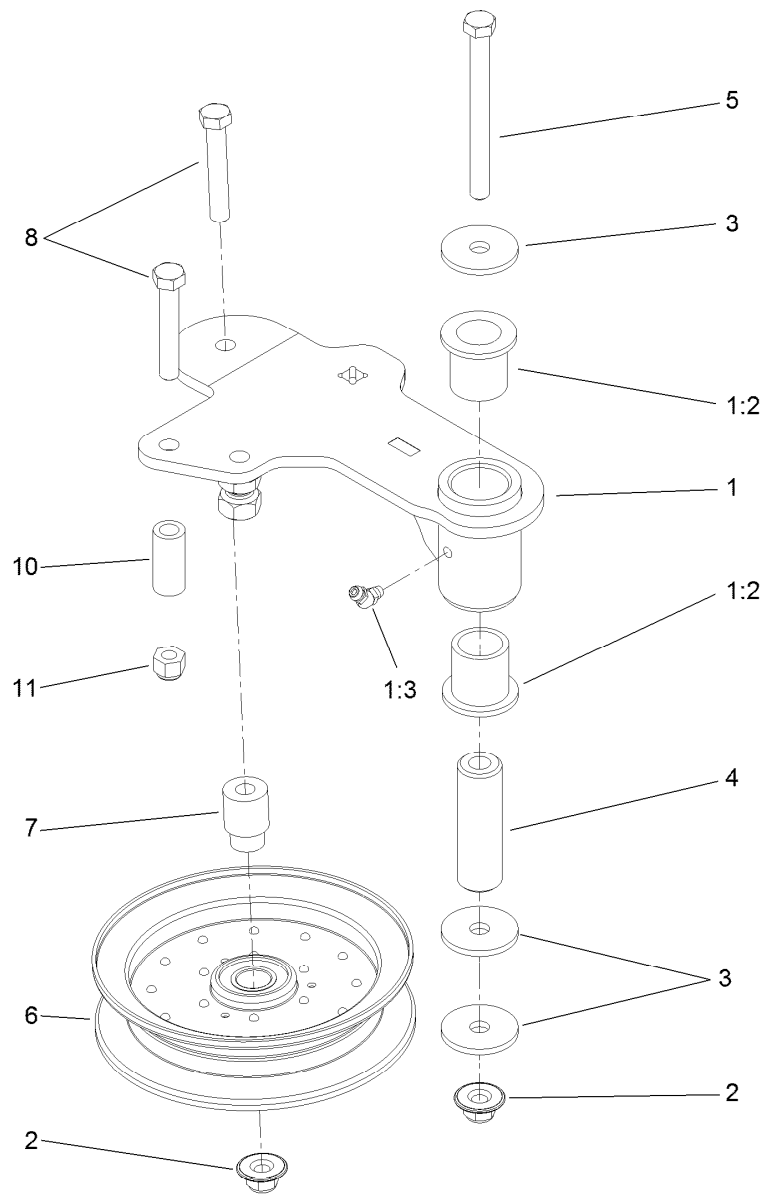

## Idler Assembly

<i>Ref.</i>	<i>Part Number</i>	<i>Qty.</i>	<i>Description</i>
1	120-2501	1	Idler Arm ASM
1:2	1-303514	2	Bearing-Flanged
1:3	1481	1	Fitting-Grease
2	109-6658	2	Nut-Flange, NI
3	1-213069	3	Washer
4	114-5848	1	Spacer-Plain
5	98-5961	1	Screw-HH
6	116-4668	1	Idler-Pulley, Flanged
7	112-4212	1	Mount-Pulley
8	323-11	2	Screw-HH
10	104-0151	1	Spacer
11	3296-39	1	Nut-Lock, NI

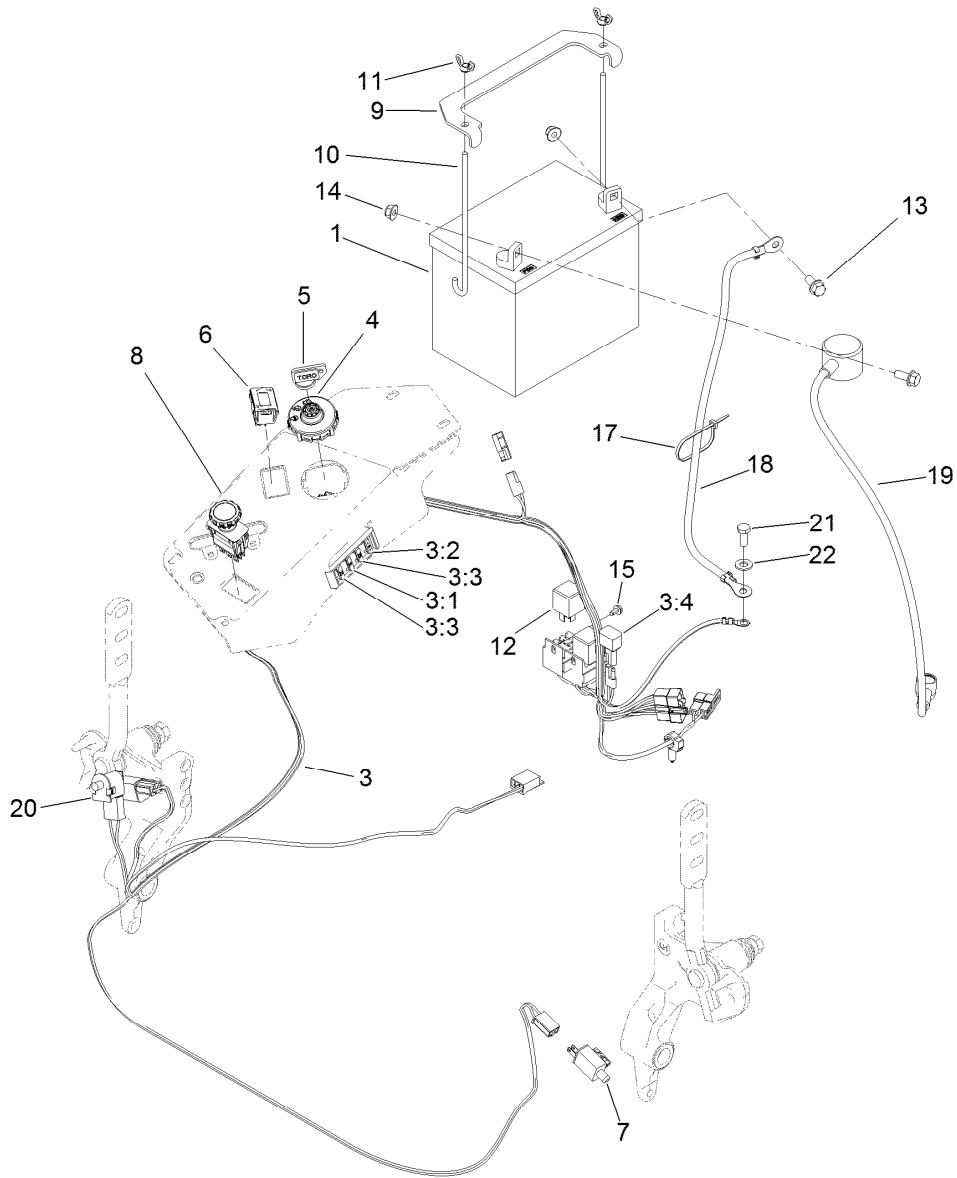

## Electrical Assembly

<i>Ref.</i>	<i>Part Number</i>	<i>Qty.</i>	<i>Description</i>	<i>Ref.</i>	<i>Part Number</i>	<i>Qty.</i>	<i>Description</i>
1	104-8162	1	Battery	10	1-633651	2	Bolt-Holddown
3	117-2582	1	Harness-Wire	11	1-543792	2	Wingnut
3:1	218-578	1	Fuse-Blade, 10 Amp	12	1-643275	2	Relay
3:2	109355	1	Fuse-Blade, 15 Amp	13	3234-5	2	Screw-HHF
3:3	109102	2	Fuse-Blade, 25 Amp	14	104-8300	2	Nut-Flange, NI
3:4	116-0053	1	Cap-Plug	15	104-2065	1	Screw-HWH
4	117-2221	1	Switch-Ignition	17	1-303287	3	Tie-Cable
5	63-8360	1	Key-Ignition (W/Shield)	18	114-1218	1	Cable-Battery, Negative
6	120-2244	1	Hourmeter	19	115-3864	1	Cable-Battery, Positive
7	110-6765	2	Switch-Single Pole No	20	82-2190	1	Switch-Bail
8	116-0124	1	Switch-PTO, 10A	21	33114-020	1	Screw-HH
9	116-0042-03	1	Strap-Tie Down, Battery	22	33094-00	1	Washer-Plain

# Attachments and Accessories

## For 74141 Z Master Riding Mower with 48in TURBO FORCE Side Discharge Mower

<b>Product Name</b>	<b>Model/Part</b>
Hypr-Oil 500 (quart) .....	114-4713
Hypr-Oil 500 (gallon).....	114-4714
Hypr-Oil 500-5 (5 gallon).....	114-4715
Bimini Folding Shade Assembly .....	115-4510
Light Kit.....	116-1154
Operator-Controlled Discharge Chute Kit .....	117-3600
Blade-hi Flo, 16.50in .....	117-7277-03
Blade-mulch, 16.50in .....	117-7278-03
Recycler Kit .....	120-2401
Z Stand Kit.....	121-4811
Deluxe Seat Kit .....	121-4812
Toro Deluxe Rider Cover.....	490-7319
Spark Arrestor Screen .....	75-6880
E-Z VAC Twin Soft Bagger.....	78569
E-Z Vac Blower and Drive Kit.....	78571
Filter Minder Gauge .....	99-4664
Trash Holder Kit.....	TC26

**Notes:**

**Notes:**

**Notes:**



**Count on it.**