



MODEL NO. 30200 – 70001 & UP

**OPERATOR'S
MANUAL**
**GROUNDMASTER® 1000L
TRACTION UNIT**

The GROUNDMASTER 1000L conforms to the American National Standards Institute's safety standards for riding mowers when weights are installed according to chart on page 11; thus, TORO proudly displays the ANSI safety seal.

To assure maximum safety, optimum performance, and to gain knowledge of the product, it is essential that you or any other operator of the mower read and understand the contents of this manual before the engine is ever started. Pay particular attention to the **SAFETY INSTRUCTIONS** highlighted by this symbol —



The safety alert symbol means **CAUTION, WARNING or DANGER** — personal safety instruction. Failure to comply with the instruction may result in personal injury.



FOREWORD

The GROUNDSMASTER 1000L was developed to satisfy the demand for a maneuverable, intermediate size, turf maintenance rotary mower. The machine has advanced concepts in engineering, design and safety; and if maintained properly, it will give excellent service.

Since the GROUNDSMASTER 1000L is a high quality product, Toro is concerned about the future use of the machine and the safety of the user. Read this manual to familiarize yourself with the proper set up, operation, and maintenance instructions. The major sections of this manual are:

1. **Safety Instructions**
2. **Set Up Instructions**
3. **Before Operating**
4. **Operating Instructions**
5. **Maintenance**

Certain information in this manual is emphasized. DANGER, WARNING and CAUTION identify personal safety related information. IMPORTANT identifies mechanical information demanding special attention. Be sure to read the directive because it deals with the possibility of damaging a part or parts of the machine. NOTE identifies general information worthy of special attention.

If help concerning set up, operation, maintenance or safety is ever needed, contact a local Authorized Toro Dealer. In addition to genuine Toro replacement parts, the dealer also has optional equipment from the complete line of Toro turf care equipment. Keep your Toro all Toro — buy genuine Toro replacement parts and accessories.

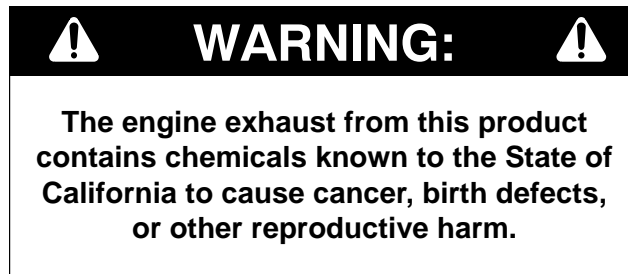

SPARK ARRESTER

Because in some areas there are local, state or federal regulations requiring that a spark arrestor muffler be used on the engine of this mower, a spark arrestor screen is available as an option. If a spark arrestor muffler is required, order the following part from you Authorized Toro Dealer.

(1) 75-6880 Spark Arrestor Screen

This part is certified to meet the requirements of USDA Forest Service Standard No. 5100-1A.

When the mower is used or operated on any California forest, brush or grass covered land, a properly operating spark arrester must be attached to the muffler. The operator is violating state law, Section 442 Public Resources Code if a spark arrester is not used.

Whenever you have questions or need service, contact your local authorized Toro Dealer. In addition to having a complete line of accessories and professional turf care service technicians, the dealer has a complete line of genuine TORO replacement parts to keep your machine operating properly. Keep your TORO all TORO. Buy genuine TORO parts and accessories.

TABLE OF CONTENTS

| | | | |
|--|----|--|------------|
| SAFETY INSTRUCTIONS | 4 | MAINTENANCE | 23 |
| SAFETY AND INSTRUCTION DECALS | 6 | Air Cleaner Maintenance | 23 |
| SPECIFICATIONS | 7 | Cleaning Radiator, Oil Cooler And Screen ... | 23 |
| LOOSE PARTS CHART | 8 | Changing Engine Oil And Filter | 23 |
| SET-UP INSTRUCTIONS | 9 | Servicing Fuel System | 24 |
| BEFORE OPERATING | 12 | Checking and Replacing Spark Plugs | 24 |
| Check Engine Oil | 12 | Servicing PTO Belt | 25 |
| Check Cooling System | 12 | PTO Clutch Adjustment | 25 |
| Check Hydraulic System Fluid | 13 | Changing Coolant In Cooling System | 25 |
| Fill Fuel Tank | 14 | Adjusting Transmission For Neutral | 26 |
| CONTROLS | 15 | Changing Transmission Filter | 26 |
| OPERATING INSTRUCTIONS | 17 | Adjusting Service Brakes | 27 |
| Starting and Stopping | 17 | Servicing Battery | 27 |
| Checking Interlock System | 17 | Wiring Harness Service | 27 |
| Operating Characteristics | 17 | Fuses | 27 |
| Pushing Or Towing Traction Unit | 18 | ELECTRICAL SCHEMATIC | 28 |
| LUBRICATION | 19 | HYDRAULIC SCHEMATIC | 29 |
| Greasing Bearings And Bushings | 19 | PREPARATION FOR SEASONAL STORAGE ... | 30 |
| SERVICE INTERVAL CHART | 21 | PRODUCT IDENTIFICATION | 30 |
| DAILY MAINTENANCE CHECK LIST | 22 | MAINTENANCE SCHEDULE | 31 |
| | | WARRANTY | Back Cover |



SAFETY INSTRUCTIONS

The **GROUNDMASTER 1000L** was tested and certified by **TORO** for compliance with the **B71.4-1990** specifications of the **American National Standards Institute**. Although hazard control and accident prevention partially are dependent upon the design and configuration of the machine, these factors are also dependent upon the awareness, concern, and proper training of the personnel involved in the operation, transport, maintenance, and storage of the machine. Improper use or maintenance of the machine can result in injury or death. To reduce the potential for injury or death, comply with the following safety instructions.

BEFORE OPERATING

1. Read and understand the contents of this manual before starting and operating the machine. Become familiar with the controls and know how to stop the machine and engine quickly. A free replacement manual is available by sending the complete model and serial number to:

The Toro Company
8111 Lyndale Avenue South
Minneapolis, Minnesota 55420–1196.

2. Never allow children to operate the machine. Do not allow adults to operate machine without proper instruction. Only trained operators who have read this manual should operate this machine.

3. Never operate the machine when under the influence of drugs or alcohol.

4. Remove all debris or other objects that might be picked up and thrown by the blades or fast moving components from other attached implements. Keep all bystanders away from operating area.

5. Keep all shields, safety devices and decals in place. If a shield, safety device or decal is defective, illegible or damaged, repair or replace it before operating the machine. Also tighten any loose nuts, bolts or screws to ensure machine is in safe operating condition.

6. Always wear substantial shoes. Do not operate machine while wearing sandals, tennis shoes, sneakers or when barefoot. Do not wear loose fitting clothing that could get caught in moving parts and possibly cause personal injury. Wearing safety glasses, safety shoes, long pants and a helmet is advisable and required by some local ordinances and insurance regulations.

7. Check interlock switches daily for proper operation (Refer To Checking Interlock Switches, Page 17). Do not rely entirely on safety switches -shut off engine before getting off seat. If a switch fails, replace it before operating the machine. The interlock system is for your protection, so do not bypass it. Replace all interlock switches every two years. Interlock switches should be adjusted so:

- A. Engine cannot be started unless traction pedal is released (neutral position)—and PTO lever is DISENGAGED (off position).
- B. Engine stops if operator gets off seat when traction pedal is depressed.
- C. Engine stops if operator gets off seat when PTO lever is ENGAGED (on position).

8. Grass deflectors must be installed in lowest position on side discharge units.

9. Since gasoline is highly flammable, handle it carefully:

- A. Use an approved fuel container.
- B. Do not remove fuel tank cap while engine is hot or running.
- C. Do not smoke while handling fuel.
- D. Fill fuel tank outdoors and only to within an inch from the top of the tank, not the filler neck. Do not overfill.
- E. Wipe up any spilled fuel.

WHILE OPERATING

10. Sit on the seat when starting and operating the machine.

11. Before starting the engine:

- A. Engage the parking brake.
- B. Make sure traction pedal is in NEUTRAL and PTO switch in OFF position.
- C. After engine is started, release parking brake and keep foot off traction pedal. Machine must not move. If movement is evident, the neutral return mechanism is adjusted incorrectly; therefore, shut engine off and adjust until machine does not move when traction pedal is released.

12. Seating capacity is one person. Therefore, never carry passengers.

13. Do not run engine in a confined area without adequate ventilation. Exhaust fumes are hazardous and could possibly be deadly.

14. Traverse slopes carefully. Do not start or stop suddenly when traveling uphill or downhill.

15. Operator must be skilled and trained in how to drive on hillsides. Failure to use caution on slopes or hills may cause loss of control and vehicle to tip or roll possibly resulting in personal injury or death.



SAFETY INSTRUCTIONS

16. This product may exceed noise levels of 85 dB(A) at the operator position. Ear protectors are recommended for prolonged exposure to reduce the potential of permanent hearing damage.

17. Using the machine demands attention and to prevent loss of control:

- A. Operate only in daylight or when there is good artificial light.
- B. Drive slowly. Avoid sudden stops and starts.
- C. Watch for holes or other hidden hazards.
- D. Look behind machine before backing up.
- E. Do not drive close to a sand trap, ditch, creek or other hazard.
- F. Reduce speed when making sharp turns and turning on a hillside.
- G. The cutting deck must be lowered when going down slopes for steering control.

18. If engine stalls or loses headway and cannot make it to the top of a slope, do not turn machine around. Always back slowly straight down the slope.

19. Never raise the cutting unit or other attached implement while the blades or other parts are rotating.

20. The grass deflector must always be installed and in the lowest position on the cutting unit. This product is designed to drive objects into the ground where they lose energy quickly in grassy areas. **DON'T TAKE AN INJURY RISK!** When a person or pet appears unexpectedly in or near the mowing area, **STOP MOWING.** Careless operation, combined with terrain angles, ricochets, or improperly positioned guards can lead to thrown object injuries. Do not resume mowing until area is cleared.

21. Do not touch engine, muffler or exhaust pipe while engine is running or soon after it is stopped. These areas could be hot enough to cause burns.

22. If cutting deck strikes a solid object or vibrates abnormally, stop immediately, turn engine off, set parking brake and wait for all motion to stop. Inspect for damage. If damaged, repair or replace any components before operating.

23. Before getting off the seat:

- A. Move traction pedal to neutral position and remove foot from pedal.
- B. Set the parking brake and turn the PTO switch OFF.

C. Shut the engine OFF and remove key from ignition switch. Wait for all machine movement to stop before getting off the seat.

MAINTENANCE

24. Before servicing or making adjustments, stop engine and remove key from the switch.

25. Make sure machine is in safe operating condition by keeping all nuts, bolts and screws tight.

26. Make sure all hydraulic line connectors are tight, and all hydraulic hoses and lines are in good condition before applying pressure to the system.

27. Keep body and hands away from pin hole leaks or nozzles that eject high pressure hydraulic fluid. Use cardboard or paper to find hydraulic leaks. Hydraulic fluid escaping under pressure can penetrate skin and cause injury. Fluid accidentally injected into the skin must be surgically removed within a few hours by a doctor familiar with this form of injury or gangrene may result.

28. Before disconnecting or performing any work on the hydraulic system, all pressure in system must be relieved by stopping engine and lowering implement to the ground.

29. If major repairs are ever needed or assistance is desired, contact an Authorized Toro Dealer.

30. To reduce potential fire hazard, keep engine area free of excessive grease, grass, leaves and dirt.

31. If engine must be running to perform maintenance or an adjustment, keep hands, feet, clothing and other parts of the body away from cutting deck and other moving parts. Keep all bystanders away.

32. Do not overspeed the engine by changing governor setting. To assure safety and accuracy, have an Authorized Toro Dealer check maximum engine speed.

33. Shut engine off before checking or adding oil to the crankcase.

34. At the time of manufacture, the machine conformed to the safety standards for riding mowers when weights are installed according to chart on page 11. To assure optimum performance and continued safety certification of the machine, use genuine Toro replacement parts and accessories. Replacement parts and accessories made by other manufacturers may result in non-conformance with the safety standards, and the warranty may be voided.



SAFETY AND INSTRUCTION DECALS

The following safety and instruction decals are affixed to the traction unit. If any decal becomes illegible or damaged, install a new decal. Part numbers are listed below and in your Parts Catalog.

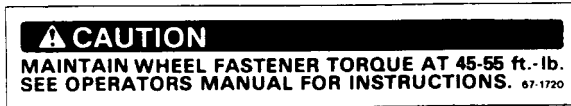

ON FRAME IN
FRONT OF DRIVE WHEELS
(Part No. 67-1720)



SEAT FRONT PLATE
(Part No. 67-1710)

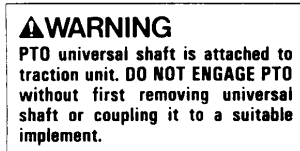

TAG ON PTO SWITCH
(Part No. 52-1420)

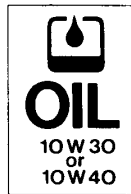

FRONT BULKHEAD
(Part No. 53-4430)

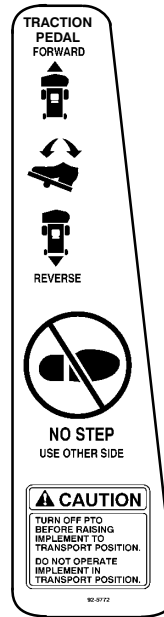

RIGHT SIDE OF PLATFORM
(Part No. 92-5772)

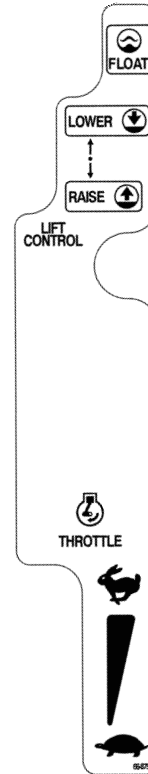

RIGHT OF SEAT
(Part No. 66-8750)

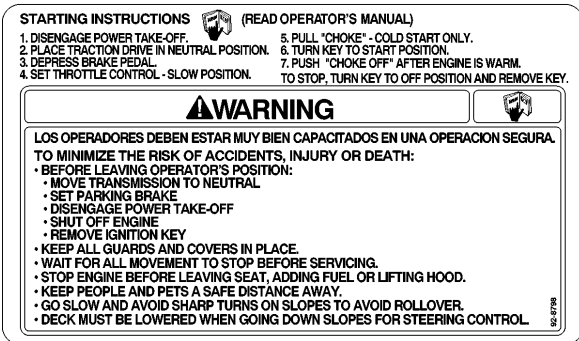

ON TOOL BOX
(Part No. 92-8798)



ON FAN SHROUD
(Part No. 76-8750)



On Muffler Shield
(Part No. 54-0910)



NEAR FUEL CAP
(Part No. 71-3730)



TOOL BOX REAR
(Part No. 27-7310)

CHECK/SERVICE

GM 1000L QUICK REFERENCE AID

- Oil Levels (Engine/Trans.)
- Coolant level
- Tire pressure
- Belt
- Fuel - Gas Only
- Battery
- Grease, Lube points
- Radiator screen
- Air Cleaner
- Electric clutch gap .015-.030
- PTO Belt tension

FLUID SPECIFICATIONS *See operator's manual for initial changes.

| | TYPE >32° F | TYPE <32° F | CAPACITY | *CHANGE INTERVALS |
|------------|---|---------------------------|----------------------------------|-----------------------------|
| Engine oil | SAE 30 SE-SF | SAE 10W-30 - 10W-40 | 1.6 QT. ^{U.S.} / 1.6 L. | oil 50 hrs. filter 100 hrs. |
| Trans oil | SAE 10W-30 - 10W-40 | TYPE F or FA Trans. Fluid | 6 QT. | * filter 200 hrs. |
| Fuel | UNLEADED GASOLINE | | 8.5 GAL. | filter 400 hrs. |
| Coolant | 50/50 MIX Ethylene glycol anti-freeze/Water | | 4 QT. | 2 years |

95-6320

INSIDE TOOL BOX COVER
(Part No. 95-6320)

SPECIFICATIONS

Engine:

Manufacturer — Kawasaki
Horsepower — 20 @ 3600 RPM.
Displacement — 617 cc.
Crankcase Capacity — 1.6 qts. w/filter.
Governor — Mechanical.
Governor Limit — 3350-3550 RPM.
Idle Speed — 1500 RPM.

Air Cleaner: Kawasaki duel element filter.

Fuel Tank Capacity: 8.5 gal.

Fuel Filter: Replaceable inline type.

Fuel Pump: 12 volt electric (transistor type).

Cooling System:

Radiator — Approx. 4 qt. capacity.
Expansion Tank — Remote mounted; 1/2 qt. capacity. System contains a 50/50 mix of ethylene glycol anti-freeze and water.

Electrical: Battery — 12 volt, BCI group size 26. 530 Amp at 0° F. 20 amp alternator with regulator/rectifier.

Drive Coupling: Transmission driven by steel shaft with flexible rubber couplings at each end.

Transmission;

Manufacturer & Type — Sundstrand hydrostatic, Type U15.
Normal Charge Pressure — 70-150 psi (483-1034 kPa).
Implement Relief Setting — 700-800 psi (4 826 - 5 516 kPa).

Hydraulic Filter: 25 micron mounted directly to transmission. Replaceable (Toro Part No. 23—2300).

Drive Axle: Manufacturer — Dana Corp., Model GT-20. Axle serves as a hydraulic fluid reservoir and mates directly with the transmission. Approximately 5 qt. capacity.

Brakes: Mechanical drum type, 7 in. dia. x 1-3/4 in. wide. Individually controlled by two pedals connected by cable and conduit for steering assist. Pedals may be latched together for two wheel braking. Lever provided for parking brake.

Tires, Wheels, Pressure:

Front Tires — 23 x 8.50 - 12
Rear Tires — 16 x 6.50 - 8
All tires 4 ply rating, tubeless type.
Pressure — 20 psi.

Steering: 13 in. steering wheel. TRW power steering valve.

Main Frame: Frame is welded, formed steel.

Seat: Adjustable contoured fit with suspension lever.

Instrumentation: Fuel gauge, water temperature gauge, hour meter and warning lights for high temperature shutdown, oil pressure and amperage are mounted on the console.

Controls: Throttle, choke, PTO switch, parking brake, implement lift and ignition switch are all hand-operated. Forward/reverse traction pedal and turning brakes are foot operated.

PTO Drive: Splined PTO shaft is clutched by a torque-teamed HA Section, spring tensioned V-belt directly from engine output shaft. PTO shaft engaged by electric clutch/brake assembly. PTO speed — 2200 RPM @ 3450 RPM engine speed.

Implement Connection — Universal joint and telescoping shaft assembly.

Lift Cylinders: Two, with 2 in. bore, 3.5 in. stroke.

Interlock Switches: Prevents engine starting if traction pedal or PTO switch are engaged. Stops engine if operator leaves seat with either traction pedal or PTO switch engaged.

Dimensions and Weight (approx.):

Traction Unit w/Standard Seat

| | |
|----------------------|---------|
| Length: | 82 in. |
| Width: (Rear Wheels) | 44 in. |
| Height: | 50 in. |
| Weight: | 1116 lb |

OPTIONAL EQUIPMENT

52" Side Discharge Cutting Unit—Model No. 30555

52" Rear Discharge Cutting Unit—Model No. 30568

62" Side Discharge Cutting Unit—Model No. 30564

62" Guardian Recycler Cutting Unit—Model No. 30569

72" Side Discharge Cutting Unit—Model No. 30575

48" V-Plow Kit — Model No. 30750

V-Plow Mounting Kit — Model No. 30749. Required with 30750 V-Plow. 11-0390 Tire Chains recommended.

Arm Rest Kit — Part No. 88—3230

Rear Discharge Shield Kit — Model No. 30567.

Rear Weight Box Kit — Part No. 24—5780.

Grass Collection System — Model No. 30502, 52" Blower Kit (for Model 30555 deck) or Model 30503 62" Blower Kit (for Model 30564 deck) can be used with either Model No. 30504, 9 cu. fit. Hopper Kit or Model No. 30505, 15 cu. ft. Hopper Kit.

Wide Tires w/rim: 23 x 10.5 - 12 — Part No. 62—7020.

Wheel Weights: — Part No. 11—0440. 50 lb (23 kg).

Rear Weight Kit — Part No. 24—5780. 70 lb (31.8 kg).

Weight Kit—20 lb. — Part No. 92—8763.

Tire Chains — Part No. 11—0390.

Deluxe Suspension Seat Kit — Model No. 30239.

Refer to Specifications section of individual Cutting Unit Operator's Manuals for cutting unit options.

LOOSE PARTS

NOTE: Use this chart as a checklist to assure all parts have been received. Without these parts, total set-up cannot be completed.

| DESCRIPTION | QTY. | USE |
|--|-----------------------|--|
| Steering Wheel Nut Screw Cap | 1 1 1 1 | Install steering wheel. |
| Seat Assembly Clevis Pin Cotter Pin 3/4 x 3/4" lg. Flat Washer Cotter Pin 1/8 x 1" lg. | 1 2 2 1 1 | Install Seat Assembly |
| Roll Pin Capscrew 5/16 - 18 x 1-3/4 in. Locknut 5/16 - 18 | 1 2 2 | Secure universal shaft to implement. |
| Cylinder Pin Cotter Pin 3/16 x 1-1/2 in. | 2 4 | Secure deck lift arms to lift cylinders. |
| Brake Return Springs Pivot Pin Assemblies Cotter Pin 1/8 x 1-1/4 in. | 2 2 2 | Mount deck lift arms. |
| Operator's Manual (Traction Unit) Parts Catalog | 2 1 | |
| Registration Card | 1 | Fill out and return to Toro |

SET-UP INSTRUCTIONS



WARNING

PTO universal shaft is attached to traction unit frame. **DO NOT ENGAGE PTO** without first removing universal shaft or coupling it to a suitable implement.

INSTALL STEERING WHEEL

1. Remove steering wheel from seat plate. Remove screw and cap from steering wheel (Fig.1).
2. Remove jam nut from steering shaft. Make sure foam seal is on steering shaft (Fig.1). Slide steering wheel onto steering shaft.
3. Secure steering wheel to shaft with jam nut and tighten it to 10–15 ft–lb.
4. Mount cap to steering wheel with screw.

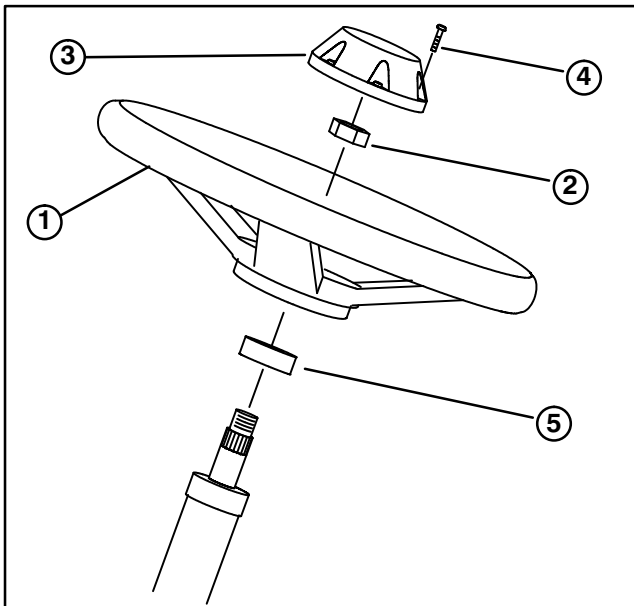

Figure 1

- | | |
|-------------------|--------------|
| 1. Steering wheel | 4. Screw |
| 2. Jam nut | 5. Foam seal |
| 3. Cap | |

INSTALL SEAT

Note: Traction unit shipped with standard seat.

1. Position seat assembly onto seat frame aligning hinge tubes (Fig. 2).
2. Secure seat plate to seat frame with (2) clevis pins and 3/4 x 3/4" lg cotter pins (Fig. 2).
3. Pivot seat forward and insert end of support rod into slot in locking plate. Secure rod to plate with a flat washer and 1/8 x 1" lg. cotter pin (Fig. 3).

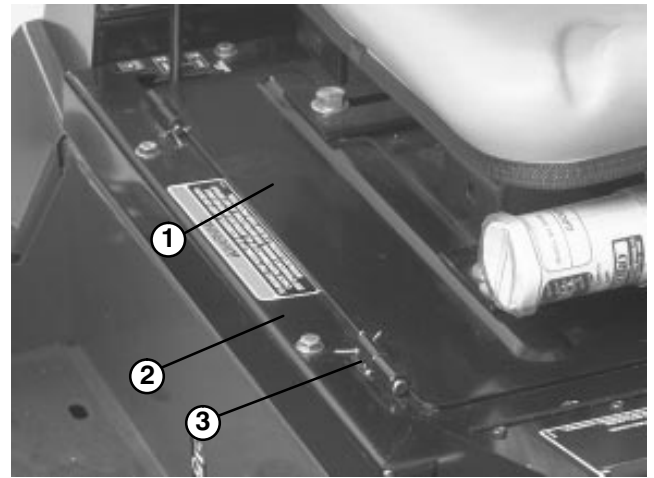

Figure 2

1. Seat assembly
2. Seat frame
3. Hinge tube

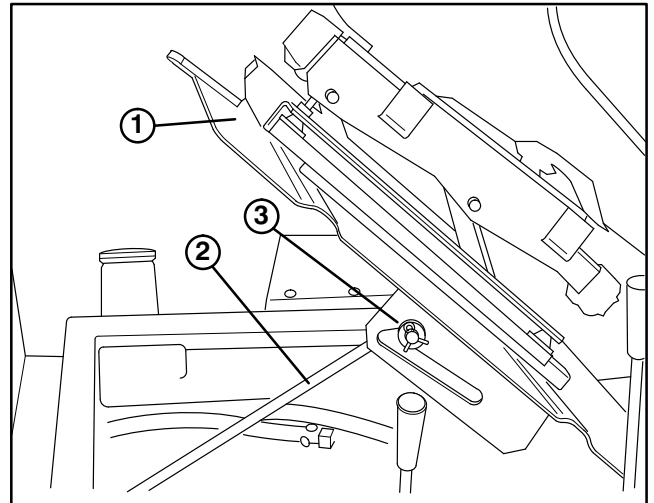

Figure 3

1. Mounting plate
2. Support rod
3. Flat washer & cotter pin

4. Lower seat and secure mounting pin to locking spring flap with a hair pin cotter (Fig. 4).

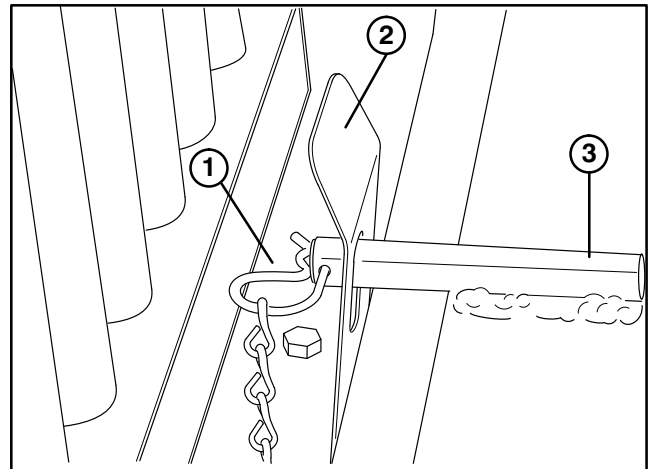

Figure 4

1. Hairpin cotter
2. Locking spring flap
3. Seat mounting pin

SET-UP INSTRUCTIONS

5. Adjust seat to desired operating position. Loosen adjustment handles, slide seat fore or aft in slotted holes and tighten adjustment handles to secure in place.

INSTALL OPTIONAL SUSPENSION SEAT Model 30239

1. Remove seat and seat springs from seat base.
2. Mount each seat adapter bracket to seat with (2) 5/16-18 x 3/4" lg. capscrews, flatwashers and lockwashers, positioning as shown in figure 5.

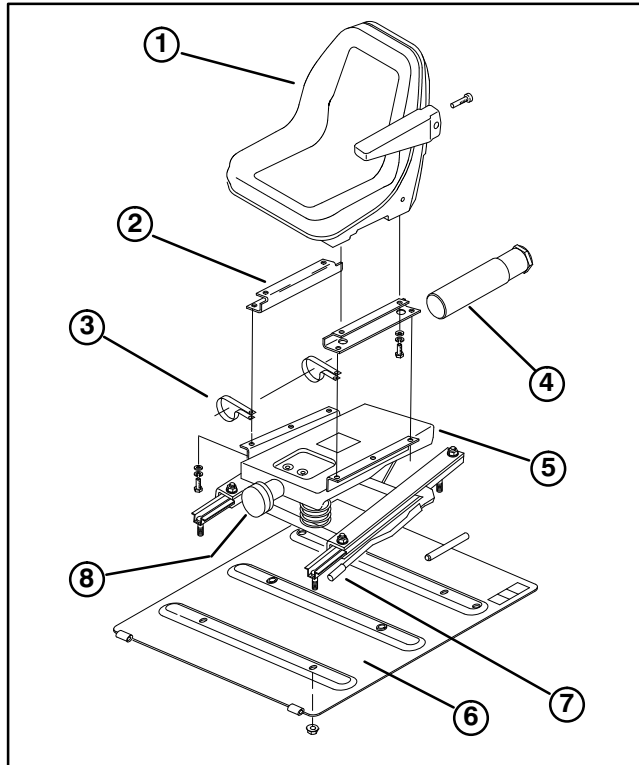

Figure 5

- | | |
|-----------------|------------------------|
| 1. Seat | 5. Suspension |
| 2. Seat adapter | 6. Seat base |
| 3. R-clamp | 7. Handle |
| 4. Manual tube | 8. Spring tension knob |

3. Loosely mount right seat adapter bracket and (2) R-clamps to right side of suspension with (2) 5/16-18 x 3/4" lg. capscrews, flatwashers and lockwashers. Position R-clamps as shown in figure 5.

4. Install manual tube into R-clamps, insert manual into tube and thread cap into tube (Fig. 5) Tighten capscrews.

5. Mount left seat adapter bracket to left side of suspension with (2) capscrews, flatwashers and lockwashers.

6. Insert threaded mounting studs of deluxe suspension into holes in seat base.

7. Secure mounting studs to seat base with (4) locknuts.

8. Assemble arm rest brackets to arm rests per instructions included with kit.

10

9. Install each arm rest bracket to each side of seat with (3) socket head capscrews supplied in kit.

10. Adjust seat for operator's weight and comfort:

- To adjust seat fore and aft, pull handle on left side outward, move seat to desired position and release lever to lock seat in position.
- To adjust for operator's weight, turn spring tension knob; clockwise to increase tension, counterclockwise to decrease tension.

CONNECT BATTERY

1. Lift engine cover. Check to see that the battery is securely fastened in place (Fig. 6).



Figure 6

1. Battery
2. Battery securing bolt (2)

2. Check battery charge with a hydrometer. If battery needs charging, be sure at least one of the battery cables is disconnected from the battery before the charger is connected.

3. Remove tape from battery cables and secure the cables to the proper battery post. The positive (+) red cable goes to the positive post and the negative (-) black cable goes to the negative post on the battery.



WARNING

Connecting cables to the wrong post could damage the electrical system and result in personal injury.

Note: Make sure battery cables are routed away from any sharp edges or moving parts.

4. Coat the terminal with sealant such as Grafo 112X, Toro Part No. 505-47 and install the rubber boots onto terminals.

CHECK TIRE PRESSURE

The tires are over-inflated for shipping. Therefore, release some of the air to reduce the pressure. Correct air pressure in front and rear tires is 20 psi.

SET – UP INSTRUCTIONS

INSTALL REAR WEIGHT

Two Wheel Drive Groundsmaster 1000 Series Traction Units comply with ANSI B71.4–1990 Standard when equipped with rear weight. 35 lbs. of rear weight is installed, at the factory, on the Groundsmaster 1000L Traction Unit. Use chart below to determine combinations of additional weight requirements. Order parts from your local Authorized Toro Distributor.

| | Additional Rear Weight Required | Left Side Weight Required | Weight Part Number | Weight Description | Qty. |
|--|---------------------------------|---------------------------|--|--|----------------------------|
| 52" Rear Discharge Deck (Model 30568) | 0 lb. | 0 lb. | – | – | – |
| 52" Side Discharge Deck (Model 30555) | 0 lb. | 0 lb. | – | – | – |
| 52" Side Discharge Deck w/ 9 cu. ft. Hopper | 0 lb. | 0 lb. | – | – | – |
| 52" Side Discharge Deck with 15 cu. ft. Hopper | 0 lb. | 285 lb. | *77–6700 & 92–9670 & 24–5780 | 75 lb. Wheel Weight & Bracket Kit & Rear Weight Kit | 1 1 3 |
| 62" Side Discharge Deck (Model 30564) | 55 lb. | 0 lb. | 24–5790 325–14 3253–7 57–4230 3217–9 & 92–8763 | Rear Weight–35 lb. Screw Lockwasher Spacer Nut & Weight Kit–20 lb. | 1 2 2 2 2 1 |
| 62" Side Discharge Deck with 9 cu. ft. Hopper | 70 lb. | 0 lb. | 24–5780 | Rear Weight Kit | 1 |
| 62" Side Discharge Deck with 15 cu. ft. Hopper | 0 lb. | 215 lb. | *77–6700 & 92–9670 & 24–5780 | 75 lb. Wheel Weight & Bracket Kit & Rear Weight Kit | 1 1 2 |
| 62" Guardian Recycler Deck (Model 30569) | 70 lb. | 0 lb. | 24–5780 | Rear Weight Kit | 1 |
| 72" Side Discharge Deck (Model 30575) | 90 lb. | 0 lb. | 24–5780 & 92–8763 | Rear Weight Kit & Rear Weight–20 lb. | 1 1 |

*75 lb. wheel weight (included with a 15 cu. ft. Hopper) required on left wheel

BEFORE OPERATING

CHECK ENGINE OIL

The engine is shipped with 1.6 qt. of oil in the crankcase; however, level of oil must be checked before and after the engine is first started.

1. Position machine on a level surface.
2. Open the hood.
3. Remove dipstick and wipe it with a clean rag. Insert dipstick into the tube and make sure it is fully seated. Remove dipstick and check level of oil (Fig. 7). If oil level is low, remove oil fill cap (Fig. 8) and add enough oil to raise level to FULL mark on dipstick. Do not overfill.

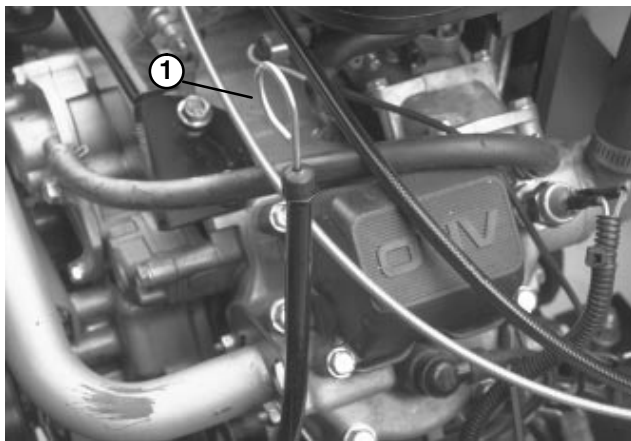

Figure 7

1. Engine oil dipstick

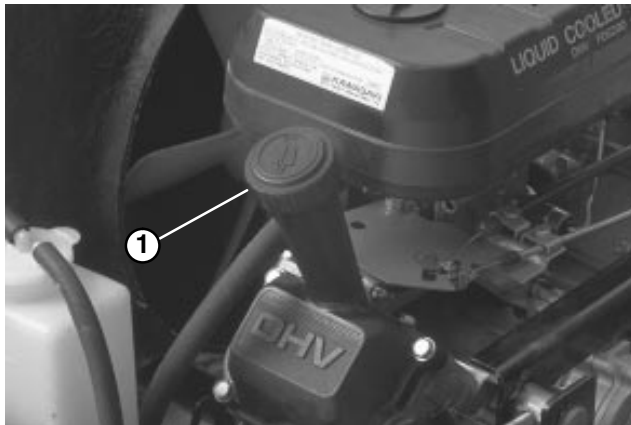
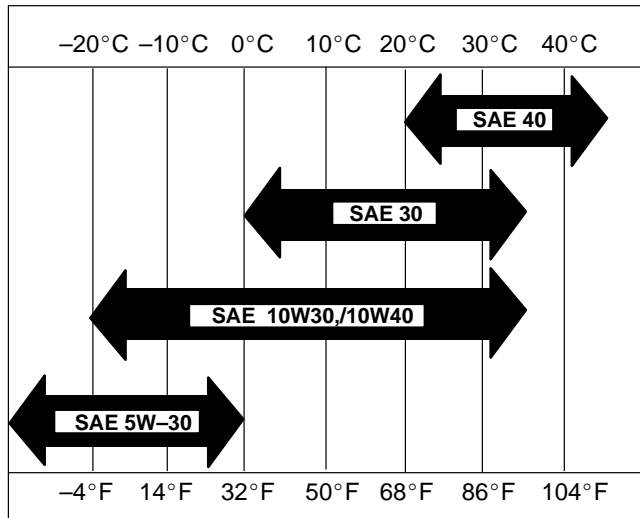

Figure 8

1. Engine oil fill

Note: If level of oil is at the ADD mark on the dipstick, add 1 pint of oil and recheck level. Do not overfill.

4. The engine uses any high-quality detergent oil having the American Petroleum Institute — API — "service classification" SE or SF. Use the following chart to select the proper viscosity grade for the temperature expected.



Note: Using multi grade oils (5W-20, 10W-30 and 10W-40) will increase oil consumption. Check oil level more frequently when using them.

IMPORTANT: Check oil level every 5 operating hours or daily. Change oil initially after the first 8 hours of operation thereafter change oil every 100 hours and filter after every 200 hours of operation.

5. Insert dipstick into tube and install fill cap.

CHECK COOLING SYSTEM

Clean debris off screen, oil cooler and front of radiator daily (Fig. 9), hourly if conditions are extremely dusty and dirty; refer to Cleaning Radiator and Screen Section.

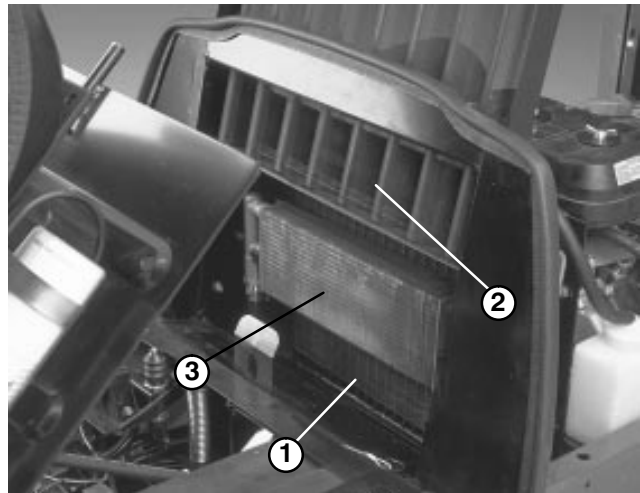

Figure 9

1. Radiator
2. Radiator screen
3. Oil cooler

The cooling system is filled with a 50/50 solution of water and permanent ethylene glycol anti-freeze. Check level of coolant at beginning of each day (Fig. 10) before starting the engine. Capacity of cooling system is approximately 4 quarts.

1. Carefully remove radiator cap and the expansion tank cap.

BEFORE OPERATING



CAUTION

If engine has been running, pressurized hot coolant can escape when radiator cap is removed and cause burns.

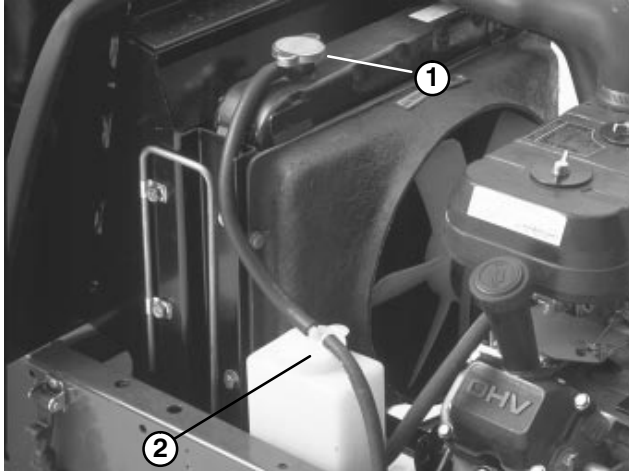

Figure 10

1. Radiator cap
2. Expansion tank cap

2. Check level of coolant in radiator. Radiator should be filled to the top of the filler neck and the expansion tank filled to between the marks on its side.
3. If coolant level is low, replenish the system. **DO NOT OVERFILL.**
4. Install radiator cap and expansion tank cap.

CHECK HYDRAULIC SYSTEM FLUID

The hydraulic system was designed to operate on any high quality detergent oil having the American Petroleum Institute—API—“service classification” SF, CC or CD. Oil viscosity — weight — must be selected according to anticipated ambient temperature. Temperature/viscosity recommendations are:

| Expected Ambient Temperature | Recommended Viscosity and Type |
|------------------------------|---|
| (Extreme) over 90° F | SAE 30, Type SF, CC or CD engine oil. |
| (Normal) 40-100° F | SAE 10W-30 or 10W-40. Type SF, CC or CD engine oil. |
| (Cool—Spring/Fall) 30–50° F | SAE 5W-30, Type SF, CC or CD engine oil. |
| (Winter) Below 30° F | Type “F” or “FA” ATF Automatic Transmission Fluid. |

Note: Do not mix engine oil and automatic transmission fluid or hydraulic component damage may result. When changing fluids, also change transmission filter. **DO NOT USE DEXRON II ATF.**

The axle housing acts as the reservoir for the system. The transmission and axle housing are shipped from the factory with approximately 6 quarts of SAE 10W-30 engine oil. However, check level of transmission oil before engine is first started and daily thereafter.

1. Position machine on a level surface. Place all control in neutral position and start the engine. Run engine at lowest possible RPM to purge the system of air. **DO NOT ENGAGE PTO.** Cycle steering wheel several times fully to the left and right. Raise the cutting unit to extend lift cylinders, aiming steering wheels straight forward and stop the engine.

2. Remove dipstick cap (Fig. 11) from filler neck and wipe it with a clean rag. Screw dipstick cap finger-tight onto filler neck; then remove it and check level of fluid. If level is not within 1/2 inch from the groove in the dipstick (Fig. 11), add SAE 10W-30 engine oil, or, if used, automatic transmission fluid to raise level to groove mark. Do not overfill.

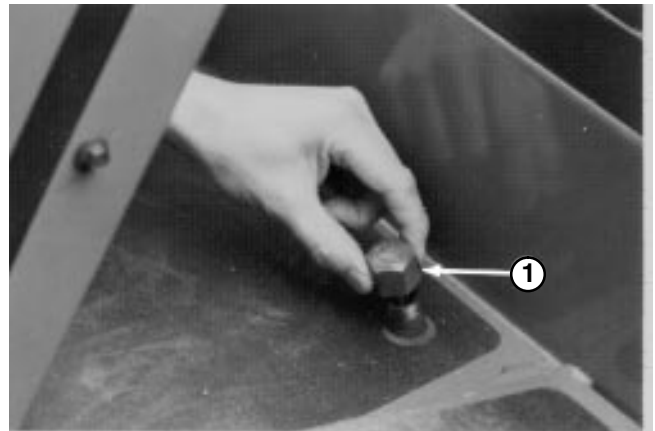

Figure 11

1. Hydraulic system reservoir fluid/add dipstick cap

IMPORTANT: When adding transmission fluid to the hydraulic system, use a funnel with a fine wire screen — 200 mesh or finer — and make sure funnel and transmission fluid are immaculately clean. This procedure prevents accidental contamination of the hydraulic system.

3. Thread dipstick fill cap finger-tight onto filler neck. It is not necessary to tighten cap with a wrench.
4. Check all hoses and fittings for leaks.

BEFORE OPERATING

FILL FUEL TANK

THE TORO COMPANY STRONGLY RECOMMENDS THE USE OF FRESH, CLEAN, UNLEADED REGULAR GRADE GASOLINE IN TORO GASOLINE POWERED PRODUCTS. UNLEADED GASOLINE BURNS CLEANER, EXTENDS ENGINE LIFE, AND PROMOTES GOOD STARTING BY REDUCING THE BUILD-UP OF COMBUSTION CHAMBER DEPOSITS. LEADED GASOLINE CAN BE USED IF UNLEADED IS NOT AVAILABLE.

NOTE: NEVER USE METHANOL, GASOLINE CONTAINING METHANOL, GASOLINE CONTAINING MORE THAN 10% ETHANOL, GASOLINE ADDITIVES, PREMIUM GASOLINE OR WHITE GAS BECAUSE ENGINE FUEL SYSTEM DAMAGE COULD RESULT.

Fuel tank capacity is 8.5 gal.

1. Clean area around fuel tank cap (Fig. 12).
2. Remove fuel tank cap.
3. Fill tank to about one inch below top of tank, (bottom of filler neck). **DO NOT OVERFILL.** Then install cap.

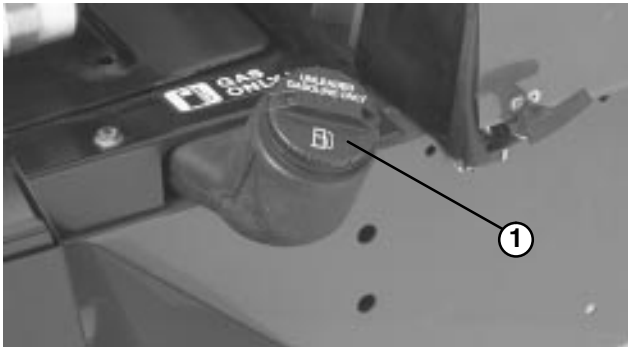

Figure 12

1. Fuel tank cap



DANGER

Because gasoline is flammable, caution must be used when storing or handling it. Do not fill fuel tank while engine is running, hot or when machine is in an enclosed area. Vapors may build up and be ignited by a spark or flame source many feet away. **DO NO SMOKE** while filling the fuel tank to prevent the possibility of an explosion. Always fill fuel tank outside and wipe up any spilled gasoline before starting engine. Use a funnel or spout to prevent spilling gasoline, and fill tank no higher than to bottom of filter screen. **DO NOT OVER FILL.** Store gasoline in a clean safety approved container and keep the cap on the container. Keep gasoline in a cool, well-ventilated place; never in an enclosed area such as a hot storage shed. To assure volatility, do not buy more than a 30 day supply of gasoline. Gasoline is a fuel for internal combustion engines; therefore do not use it for any other purpose. Since many children like the smell of gas, keep it out of their reach because the fumes are explosive and dangerous to inhale.

CONTROLS

Service Brakes (Fig. 13) — The left and right brake pedals are connected to the left and right front wheels. Since both brakes work independently of each other, the brakes can be used to turn sharply or to increase traction if one wheel tends to slip while operating on certain slope conditions. However, wet grass or soft turf could be damaged when brakes are used to turn sharply. To make a “quick-stop”, depress both brake pedals together. Always lock brakes together when transporting the traction unit.

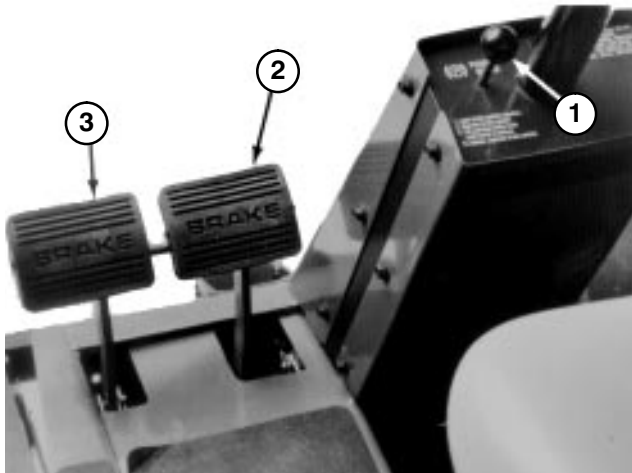

Figure 13

1. Parking brake knob
2. Right brake pedal
3. Left brake pedal

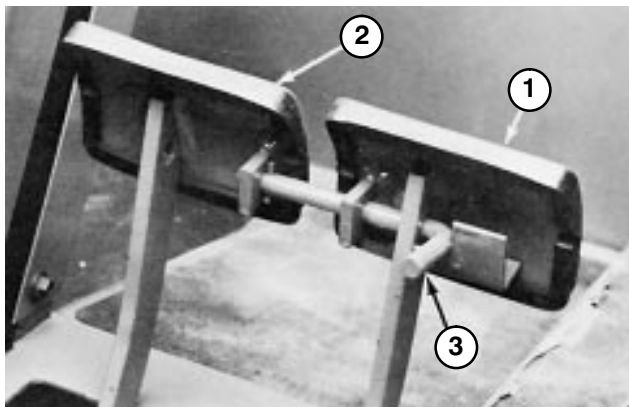

Figure 14

1. Left brake pedal
2. Right brake pedal
3. Lock arm

Parking Brake — Whenever the engine is shut off, the parking brake must be engaged to prevent accidental movement of the machine. To engage the parking brake, push lock arm (Fig. 14) on left brake pedal so that it locks together with the right pedal. Next, push down fully on both pedals and pull parking brake knob

out (Fig. 13) then release the pedals. To release parking brake, depress both pedals until parking brake knob retracts. Before starting the engine, however, lock arm may be disengaged from left brake pedal so both pedals work independently with each front wheel.

Amp Light (Fig. 15) — The amp light should be off when engine is running. If it is on, the charging system should be checked and repaired if necessary.

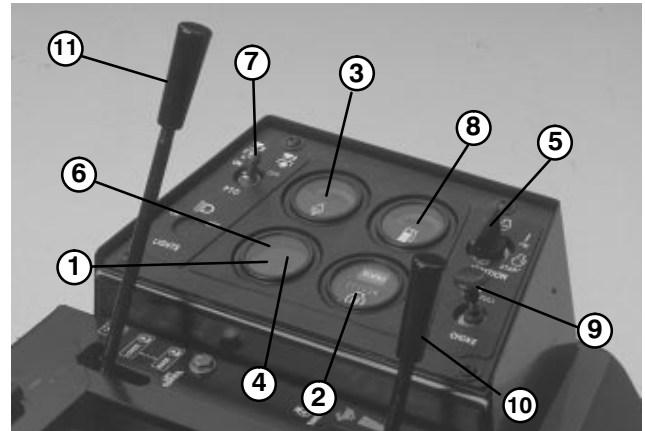

Figure 15

- | | |
|-----------------------------------|--------------------------|
| 1. Amp light | 7. PTO switch |
| 2. Hour meter | 8. Fuel gauge |
| 3. Coolant temperature gauge | 9. Choke |
| 4. High temperature shutoff light | 10. Throttle |
| 6. Oil pressure light | 11. Hydraulic lift lever |

Hour Meter (Fig. 15) — Accumulated engine operating time registers on the hour meter.

Temperature Gauge and High Temperature Light (Fig. 15) — The coolant temperature gauge registers the coolant temperature in the system. If the temperature gets too high the engine will automatically shut off and the High Temperature Shutoff Light will light. When this happens, turn the ignition key off, check radiator for debris, check the fan belt and check the expansion tank for proper coolant level. The high temperature shutoff will automatically reset when the coolant temperature has reached a safe level.

Low Oil Pressure Light (Fig. 15) — If engine oil pressure falls below a safe level, the light glows. Stop engine and repair before resuming operation.

PTO Switch (Fig. 15) — Pull up on sleeve on toggle switch handle and move handle to ON to ENGAGE electric PTO clutch. Pull up on sleeve and move handle to OFF to DISENGAGE electric PTO clutch. The only time the PTO switch should be in the ENGAGE position is when the implement is down in operating position and ready to begin operation.

CONTROLS

Ignition Key Switch (Fig. 15) — The ignition switch, which is used to start and stop the engine, has three positions: OFF, RUN and START. Rotate key clockwise — START position — to engage starter motor. Release key when engine starts. The key will move automatically to the ON position. To shut engine off, rotate key counterclockwise to the OFF position.

Choke (Fig. 15) — To start engine, close carburetor choke by pulling choke control upward. After engine starts, regulate choke to keep engine running smoothly. As soon as possible, open the choke by pushing it inward. A warm engine requires little or no choking.

Throttle (Fig. 15) — Throttle is used to operate engine at various speeds. Moving throttle forward increases engine speed — FAST; rearward decreases engine speed — SLOW. The throttle controls the speed of the cutter blades and, in conjunction with traction pedal, controls ground speed of the traction unit.

Hydraulic Lift Lever (Fig. 15) — The hydraulic lift lever has three positions: FLOAT, TRANSPORT and RAISE. To lower cutting unit to the ground, move lift lever forward into notch in seat platform — FLOAT. The FLOAT position is used for mowing and when machine is not in operation. To raise cutting unit, pull lift lever rearward to the RAISE position. After cutting unit is raised, allow lift lever to move to the TRANSPORT position. Cutting unit must be raised when driving from one work area to another.



CAUTION

Never raise cutting unit while blades are rotating because it is hazardous.

Traction Pedal (Fig. 16) — Traction pedal has two functions: one is to make the machine move forward, the other is to make it move rearward. Using the heel and toe of the right foot, depress top of pedal to move forward and bottom of pedal to move rearward. Ground speed is proportionate to how far pedal is depressed. For maximum ground speed, traction pedal must be fully depressed while throttle is in FAST position. Maximum speed forward is 11 mph (approx.). To get maximum power under heavy load or when ascending a hill, have throttle in FAST position while depressing traction pedal slightly to keep engine rpm high. When engine rpm begins to decrease, release traction pedal slightly to allow rpm to increase.

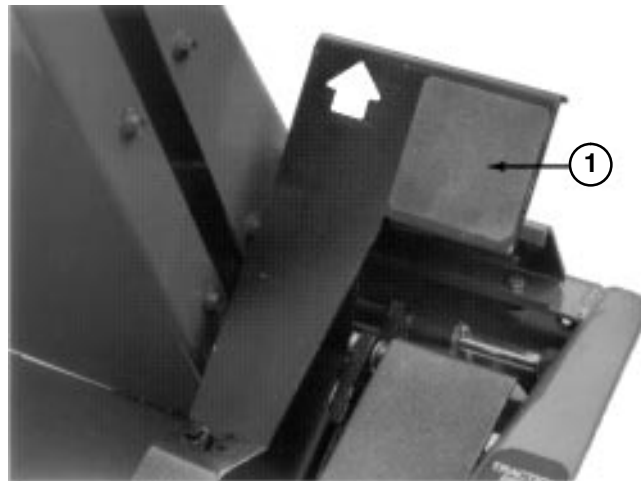

Figure 16

1. Traction pedal

Seat Adjusting Handle — To adjust seat, loosen adjusting knobs and slide seat to desired position. Tighten knobs to lock seat in place.

OPERATING INSTRUCTIONS

STARTING/STOPPING ENGINE

1. Ensure parking brake is set, PTO switch is in OFF position and lift lever is in TRANSPORT or FLOAT position (Fig. 15). Remove foot from traction pedal and insure it is in neutral.

2. Pull choke (Fig. 15) to full choke position and move throttle control (Fig. 15) to slow position.

3. Turn key in ignition switch to START position (Fig. 15). Release key immediately when engine starts and allow it to return to RUN position. Regulate choke to keep engine running smoothly.

Note: Do not run starter motor more than 5 seconds at a time or premature starter failure may result. If engine fails to start after 5 seconds, turn key to OFF position, recheck controls and procedures, wait 10 additional seconds and repeat starter operation.

4. When engine is started for the first time, or after engine oil change, or overhaul of engine, transmission or axle, operate the machine in forward and reverse for one to two minutes. Also operate the lift lever and PTO lever to assure proper operation of all parts. Turn power steering wheel to the left and right to check steering response. Then shut engine off and check fluid levels, check for oil leaks, loose parts and any other noticeable malfunctions.



5. To stop engine, move throttle control backward to SLOW position, move PTO switch to OFF position and rotate ignition key to OFF. Remove key from switch to prevent accidental starting.

CHECKING INTERLOCK SYSTEM

The purpose of the safety interlock system is to prevent the engine from cranking or starting unless the traction pedal is in neutral and the PTO switch is in the OFF position. In addition, the engine will stop when the PTO control is engaged or traction pedal is depressed with operator off the seat.



CAUTION

Do not disconnect the safety switches because they are for the operator's protection. Check operation of the switches daily to be sure the interlock system is operating correctly. If a switch is malfunctioning, replace it before operating the machine. Replace the switches every 2 years to be sure of maximum safety.

1. Move PTO switch to OFF position and remove foot from traction pedal so it is fully released.

2. Rotate the ignition key to START. Engine should crank. If engine cranks, proceed to step 3. If engine does not crank, there may be a malfunction in the interlock system.

3. Raise off the seat and engage the PTO switch while the engine is running. The engine should stop within 2 seconds. If engine stops, the switch is operating correctly; thus, proceed to step 4. If engine does not stop, there is a malfunction in the interlock system.

4. Raise off the seat and depress the traction pedal while engine is running the PTO lever is disengaged. The engine should stop within 2 seconds. If engine stops, the switch is operating correctly; thus, continue operation. If engine does not stop, there is a malfunction in the interlock system.

OPERATING CHARACTERISTICS

Practice driving the GROUNDSMASTER® 1000L before initial operation because it has a hydrostatic transmission and its characteristics are different than some turf maintenance machines. Some points to consider when operating the traction unit and cutting unit are the transmission, engine speed, load on the cutting blades, and the importance of the brakes.

To maintain enough power for the traction unit and cutting unit while mowing, regulate traction pedal to keep engine rpm high and somewhat constant. A good rule to follow is: decrease ground speed as the load on the cutting blades increases; and increase ground speed as load on the blades decreases. This allows the engine, working with the transmission, to sense the proper ground speed while maintaining high blade tip speed necessary for good quality-of-cut. Therefore, allow traction pedal to move upward as engine speed decreases, and depress pedal slowly as speed increases. By comparison, when driving from one work area to another—with no load and cutting unit raised—have throttle in FAST position and depress traction pedal slowly but fully to attain maximum ground speed.

OPERATING INSTRUCTIONS



CAUTION

Adequate rear weight is necessary to prevent the rear wheels from leaving the ground. Do not stop suddenly while cutting unit or implement is raised. Do not travel down hill with the cutting unit or implement raised. If the rear wheels leave the ground, steering is lost.

CAUTION: This product may exceed noise levels of 85 dB(A) at the operator position. Ear protectors are recommended for prolonged exposure to reduce the potential of permanent hearing damage.

Another characteristic to consider is the operation of the brakes. The brakes can be used to assist in turning the machine; however, use them carefully, especially on soft or wet grass because the turf may be torn accidentally. The brakes can be used to great advantage to control the direction of the cutting unit when trimming along fences or similar objects. The other benefit of the brakes is to maintain traction. For example; in some slope conditions, the uphill wheel slips and loses traction. If this situation occurs, depress uphill brake pedal gradually and intermittently until the uphill wheel stops slipping; thus, increasing traction on the downhill wheel. If independent braking is not desired, engage the lever on left brake pedal with right pedal. This provides simultaneous braking at both wheels.

Before stopping the engine, disengage all control and move throttle to SLOW. Moving throttle to SLOW reduces high engine speed, noise and vibration. Turn ignition key to OFF to stop the engine.

PUSHING OR TOWING TRACTION UNIT

In an emergency, the traction unit can be pushed or towed for a very short distance. However, Toro does not recommend this as standard procedure.

IMPORTANT: Do not push or tow the traction unit faster than 2 to 3 mph because transmission may be damaged. IF traction unit must be moved a considerable distance, transport it on a truck or trailer. Whenever traction unit is pushed or towed, by-pass valve must be open.

1. Remove hair pin, pivot seat platform forward and locate seat support rod in detent notch.
2. Depress and hold the pins located in the center of the two (2) check valve assemblies in the top of the transmission (Fig. 17) while pushing or towing the machine.

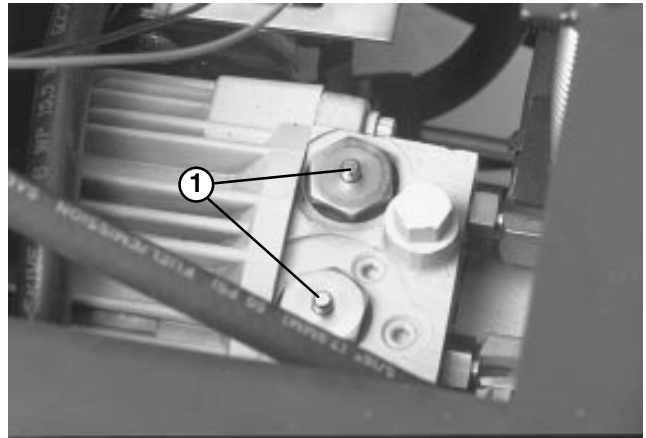

Figure 17

1. Transmission check valve bypass pins (2)
3. Start engine momentarily after repairs are completed and make sure the pins are in the full disengaged (fully up) position.

IMPORTANT: Running the machine with by-pass valve open will cause the transmission to overheat.

LUBRICATION

GREASING BEARINGS AND BUSHINGS

The traction unit has grease fittings that must be lubricated regularly with No. 2 General Purpose Lithium Base Grease. If machine is operated under normal conditions, lubricate all bearings and bushings after every 50 hours of operation or whenever water is used to clean machine. Bearings and bushings must be lubricated daily when operating conditions are extremely dusty and dirty. Dusty and dirty operating conditions could cause dirt to get into the bearings and bushings, resulting in accelerated wear.

Apply a liberal coating of grease to the check valve pins once each year (Fig. 17). The traction unit has bearings and bushings that must be lubricated, and these lubrication points are: PTO universal shaft (Fig. 18); lift arm pivot bushings (Fig. 19), front PTO bearing (Fig. 19); brake pivot bushings (Fig. 20); rear wheel spindle bushings (Fig. 21); steering plate bushings (Fig. 22); axle pin bushing (Fig. 22) PTO tension pivot (Fig. 24) and rear PTO bearing (Fig. 24). Also apply grease to both brake cables at the drive wheel and brake pedal ends (Fig. 20).

1. Wipe grease fitting clean so foreign matter cannot be forced into the bearing or bushing.
2. Pump grease into the bearing or bushing.
3. Wipe up excess grease.

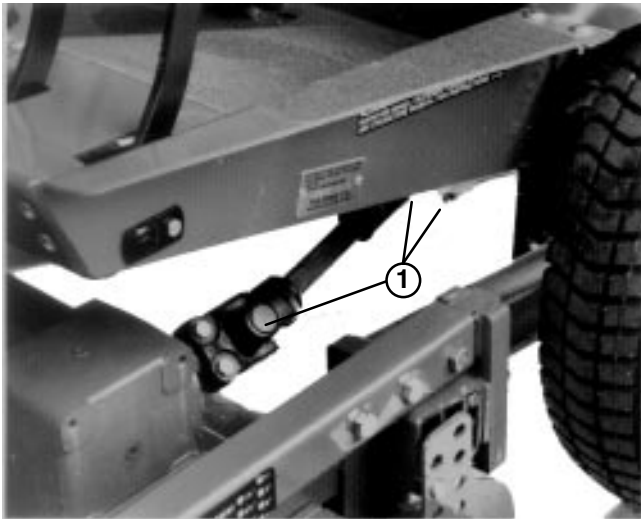

Figure 18
1. PTO shaft (3)

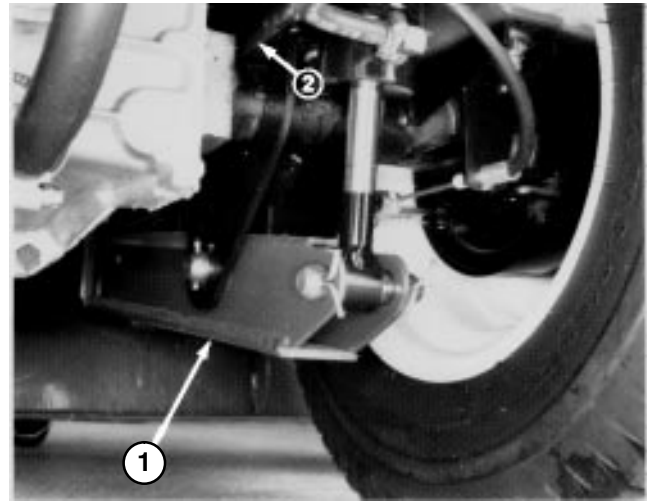

Figure 19
1. Lift arm pivot bushings (each side)
2. Front PTO bearing

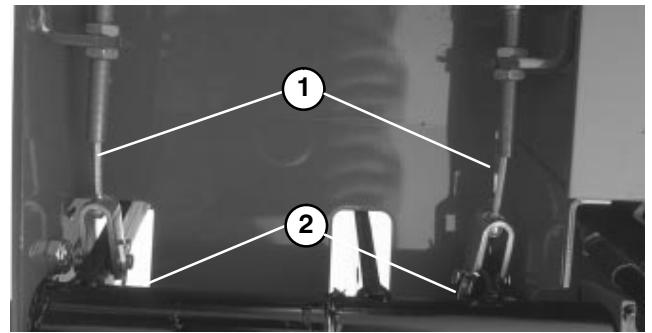

Figure 20
1. Brake cables
2. Brake pivot bushings

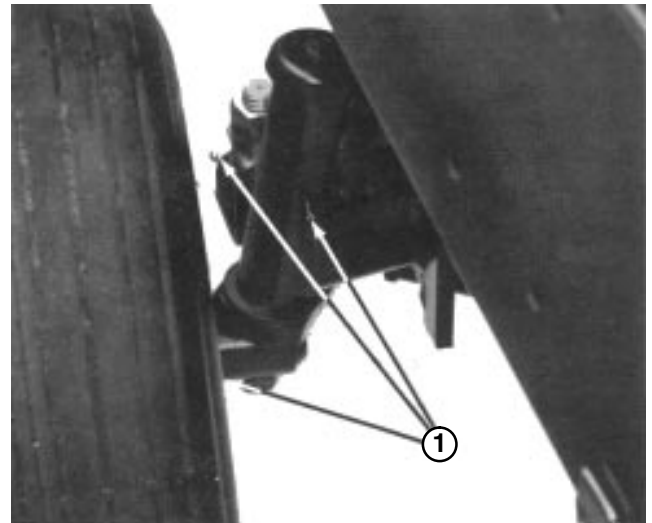

Figure 21
1. Steering arm & wheel (3)

LUBRICATION

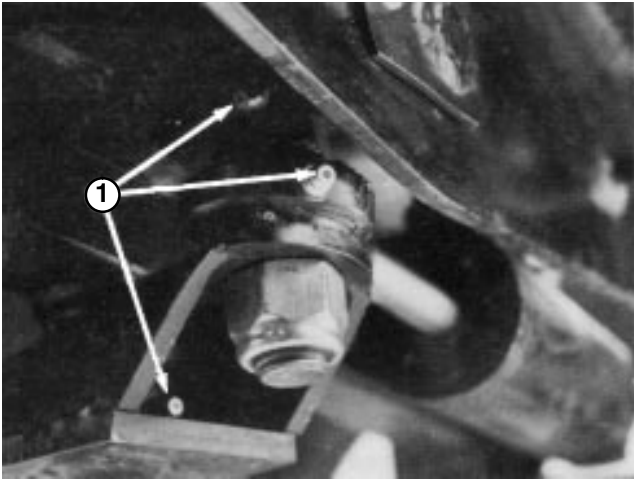

Figure 22
1. Rear axle (3)

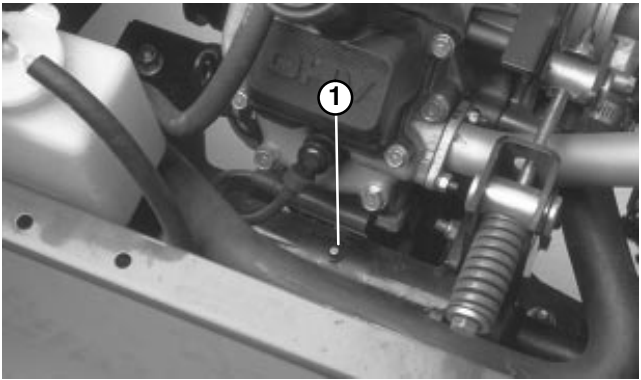

Figure 23
1. PTO tension pivot

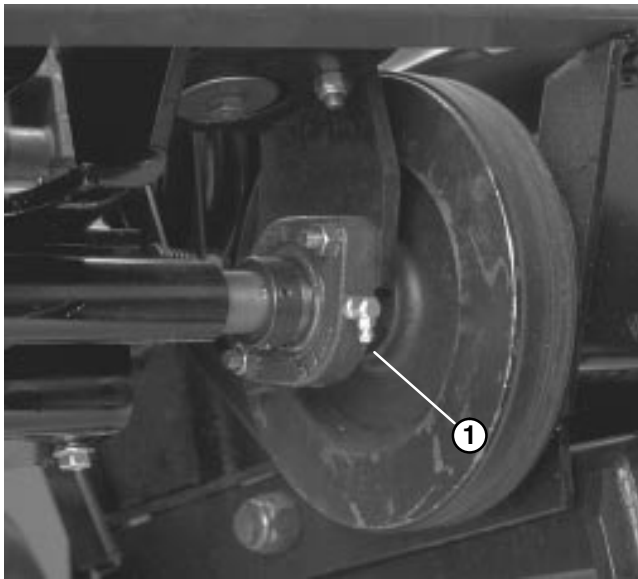

Figure 24
1. Rear PTO bearing

SERVICE INTERVAL CHART

CHECK/SERVICE



GM 1000L QUICK REFERENCE AID

1. Oil Levels (Engine/Trans.)
2. Coolant level
3. Tire pressure
4. Belt
5. Fuel – Gas Only
6. Battery
7. Grease, Lube points
8. Radiator screen
9. Air Cleaner
10. Electric clutch gap .015-.030
11. PTO Belt tension

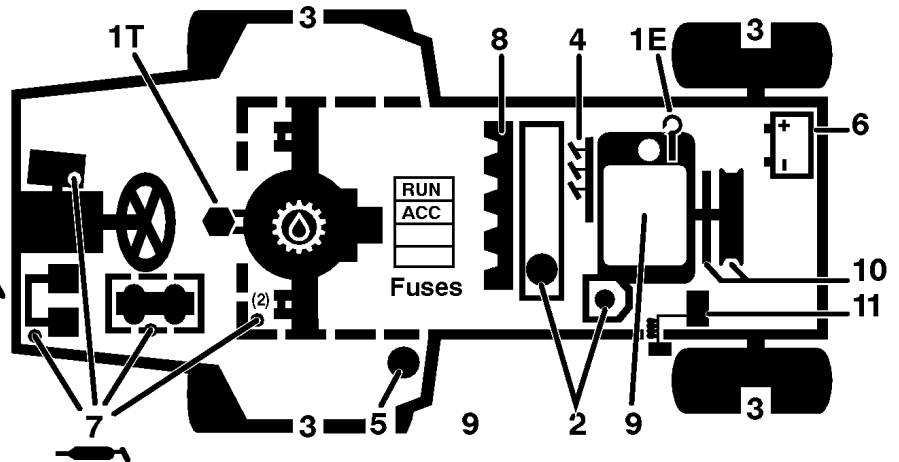

FLUID SPECIFICATIONS *See operator's manual for initial changes.

| | TYPE >32° F | | TYPE <32° F | CAPACITY | *CHANGE INTERVALS | |
|------------|---|-------|---------------------------|------------------------------------|-------------------|-----------------|
| | SAE 30 | SE-SF | SAE 10W-30 - 10W-40 | | oil | filter |
| Engine oil | SAE 30 | SE-SF | SAE 10W-30 - 10W-40 | 1.6 QT. <small>WITH FILTER</small> | oil 50 hrs. | filter 100 hrs. |
| Trans oil | SAE 10W-30 - 10W-40 | | TYPE F or FA Trans. Fluid | 6 QT. | * | filter 200 hrs. |
| Fuel | UNLEADED GASOLINE | | | 8.5 GAL. | — | filter 400 hrs. |
| Coolant | 50/50 MIX Ethylene glycol anti-freeze/Water | | | 4 QT. | 2 years | |

95-6320

DAILY MAINTENANCE CHECKLIST

Daily Maintenance: (duplicate this page for routine use)

| Maintenance Check Item ▼ | Daily Maintenance Check For Week Of _____ | | | | | | |
|--|---|------|-----|-------|-----|-----|-----|
| | MON | TUES | WED | THURS | FRI | SAT | SUN |
| ✓ Safety Interlock Operation | | | | | | | |
| ✓ Grass Deflector in Down Position | | | | | | | |
| ✓ Brake Operation | | | | | | | |
| ✓ Engine Oil Level | | | | | | | |
| ✓ Cooling System Fluid Level | | | | | | | |
| ✓ Air Filter | | | | | | | |
| ✓ Radiator & Screen for Debris | | | | | | | |
| ✓ Unusual Engine Noises | | | | | | | |
| ✓ Transmission Oil Level | | | | | | | |
| ✓ Hydraulic Hoses for Damage | | | | | | | |
| ✓ Fluid Leaks | | | | | | | |
| ✓ Tire Pressure | | | | | | | |
| ✓ Instrument Operation | | | | | | | |
| ✓ Condition of Blades | | | | | | | |
| Lubricate All Grease Fittings ¹ | | | | | | | |
| Touch-up Damaged Paint | | | | | | | |

¹ = Immediately after every washing, regardless of the interval listed.

Notation for areas of concern: Inspection performed by _____

| Item | Date | Information |
|------|------|-------------|
| 1 | | |
| 2 | | |
| 3 | | |
| 4 | | |
| 5 | | |
| 6 | | |
| 7 | | |
| 8 | | |

Check proper section of Operator's Manual for fluid specifications

MAINTENANCE

AIR CLEANER MAINTENANCE

Clean air cleaner foam element after every 50 operating hours. More frequent cleaning is required when mower is operated in dusty or dirty conditions.

1. Remove wing nuts securing air cleaner cover to air cleaner and remove cover (Fig. 25). Clean cover thoroughly .



Figure 25

1. Air cleaner cover
2. Wing nut

2. If foam element (Fig. 26) is dirty, remove it from paper element. Clean thoroughly.



Figure 26

1. Foam element
2. Paper element

A. WASH foam element in a solution of liquid soap and warm water. Squeeze to remove dirt, but do not twist because foam may tear.

B. DRY by wrapping in a clean rag. Squeeze rag and foam element to dry.

C. SATURATE element with clean engine oil. Squeeze element to remove excess oil and to distribute oil thoroughly. An oil damp element is desirable.

3. When servicing foam element, check condition of paper element (Fig. 26). Clean by gently tapping element to remove dust. Replace element yearly or every 200 hours.

4. Reinstall foam element, paper element and air cleaner cover.

IMPORTANT: Do not operate engine without air cleaner element because extreme engine wear and damage will likely result.

CLEANING RADIATOR, OIL COOLER AND SCREEN

Normally, check the radiator screen, oil cooler and front of radiator daily and, if necessary, clean any debris off these parts. Check and clean components more frequently in extremely dusty and dirty conditions.

Note: If engine shuts off due to overheating, first check the radiator and screen for excessive buildup of debris.

To thoroughly clean the radiator:

1. Remove the screen.
2. Working from the fan side of the radiator, either spray the radiator with a water hose or blow with compressed air.
3. After the radiator is thoroughly cleaned, clean out debris that may have collected in the channel at the radiator base.
4. Clean and install the screen.

CHANGING ENGINE OIL AND FILTER

Check oil level after each day's operation or each time machine is used. Change oil after first 8 hours and after every 50 hours of operation thereafter. Change oil filter after every 100 hours of operation. If possible, run engine just before changing oil because warm oil flows better and carries more contaminants than cold oil.

1. Position machine on a level surface.
2. Set drain pan under the oil pan and in line with drain plug (Fig. 27).
3. Clean area around drain plug.

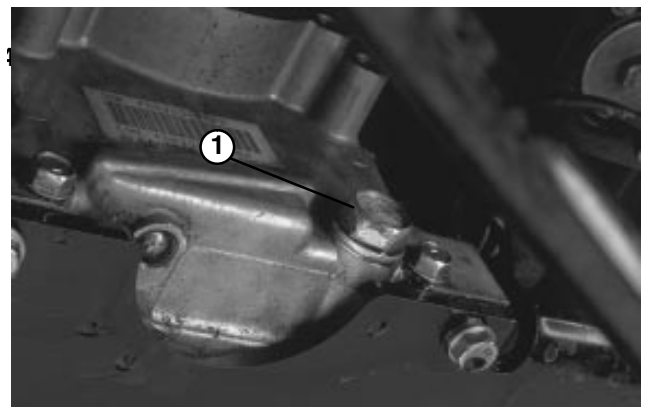

Figure 27

1. Oil drain plug

4. Remove oil drain plug and allow oil to flow into drain pan.

MAINTENANCE

5. Remove and replace oil filter (Fig. 28); refer to parts catalog for part number.

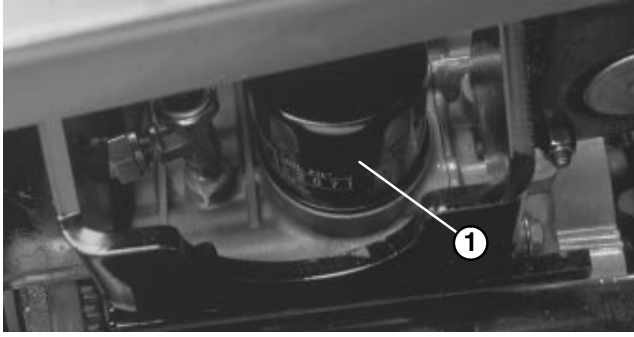

Figure 28

1. Oil drain plug

6. After oil is drained, reinstall drain plug and wipe up any oil that is spilled.
7. Fill crankcase with oil; refer to Check Engine Oil.

SERVICING FUEL SYSTEM

Fuel Tank

Drain and clean fuel if tank becomes contaminated or machine is to be stored for an extended period. Use clean solvent to flush out the tank.

Fuel Lines and Connections

Check lines and connections every 400 hours or yearly, whichever comes first. Inspect for deterioration, damage or loose connections.

Fuel Filter

Clean the fuel filter after every 50 hours or yearly, whichever comes first.

1. Clamp both fuel lines that connect to fuel filter (Fig. 29) so gasoline cannot drain when lines are removed.
2. Loosen R-clamp securing fuel filter to frame.

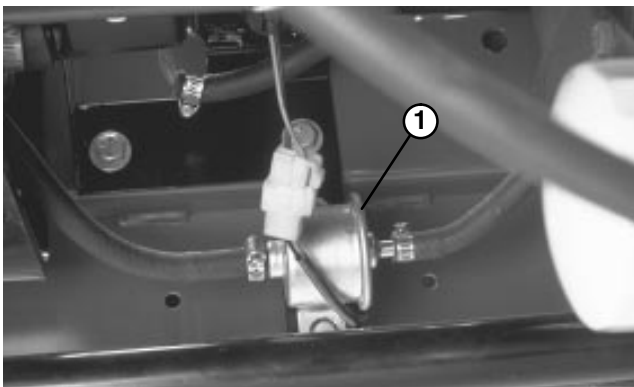

Figure 29

1. Fuel filter

3. Loosen hose clamps (Fig. 29) at each end of filter, pull fuel lines off and discard filter.
4. Be sure arrow on side of filter points toward the carburetor. Slide hose clamps onto ends of fuel lines and push fuel lines onto fuel filter.

24

5. Tighten clamps.

CHECKING AND REPLACING SPARK PLUGS

Since air gap between center and side electrodes increases gradually during normal engine operation, check condition of electrodes at 100 hour intervals. The correct spark plugs to use in the engine are NGK BMR 6A or equivalent. Set air gap at .024–.028 in.

1. Clean area around spark plugs so dirt does not fall into cylinder when plugs are removed.
2. Pull wires off spark plugs and remove plugs from cylinder head.

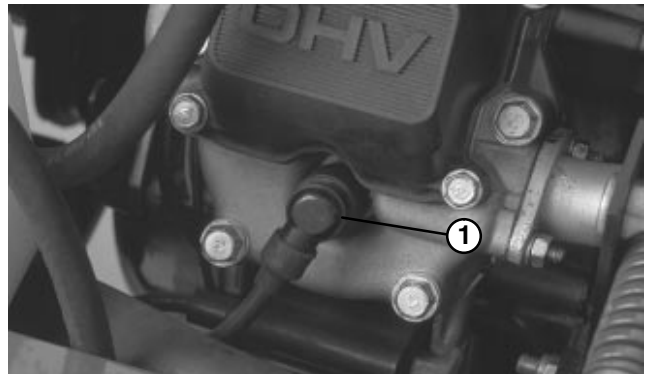

Figure 30

1. Spark plug wire

3. Check condition of center and side electrodes to determine operating temperature of engine.

- A. Light brown insulator tip indicates correct spark plug and heat range.
- B. Black or oily insulator tip indicates an excessively rich fuel mixture, possibly caused by a dirty air cleaner element or a carburetor that is set too rich.
- C. Light gray or blistered–white insulator indicates overheating caused by a lean carburetor setting or incorrect spark plug (heat range too high).

IMPORTANT: A cracked, fouled or dirty spark plug must be replaced. Do not sandblast, scrape or clean electrodes by using a wire brush because grit may release from the plug and enter combustion chamber resulting in engine damage.

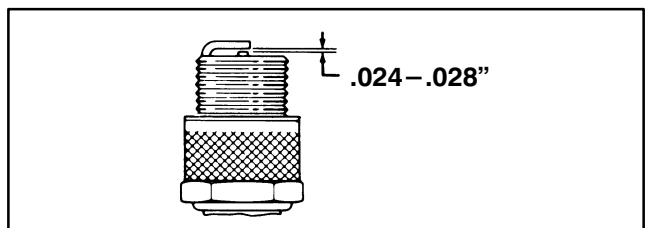

Figure 31

MAINTENANCE

4. After setting air gap at .024–.028", install spark plug in cylinder head. Tighten plugs to 17 ft–lb. Push wires onto spark plugs.

SERVICING PTO BELT

Check tension of belt initially after the first day of operation and every 100 hours thereafter.

To Check Tension:

1. Turn engine off and remove the ignition key. Set the parking brake. Raise the engine hood and allow the engine to cool.
2. Loosen the tensioning rod jam nut (Fig. 32).
3. Adjust spring to a length of 1.9".
4. Tighten jam nut.

To Replace Belt:

1. Turn off the engine and remove the ignition key. Set the parking brake. Raise the hood and allow the engine to cool.
2. Loosen the tensioning rod jam nut (Fig. 32).
3. Loosen the belt tensioning spring (Fig. 32) all the way.
4. Rotate PTO pulley toward the engine and remove the belt (Fig. 33).
5. Install the new PTO belt and re-tension the pulley spring to 1.9" (Fig. 32).
6. Tighten the jam nut (Fig. 32) and close the hood.

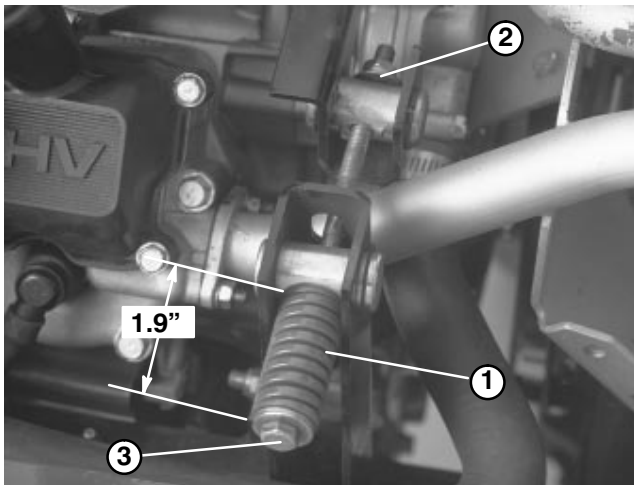

Figure 32

1. Tensioning spring
2. Tensioning rod jam nut
3. Tension adjusting bolt

PTO CLUTCH ADJUSTMENT

The power take off electric clutch can be adjusted by following the following procedure:

1. Turn engine off and remove the ignition key. Set the parking brake. Raise the engine hood and allow the engine to cool.

2. Remove bolt and nut securing nylon block and remove nylon block (Fig. 33).

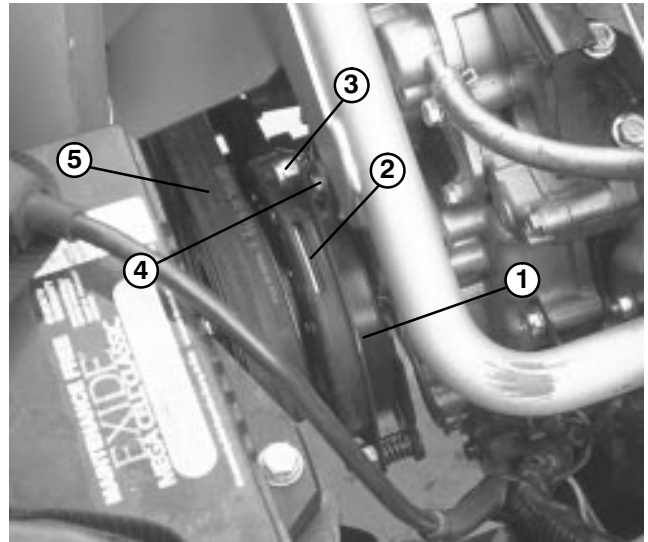

Figure 33

1. Clutch
2. .015" air gap (3)
3. Adjusting nut (3)
4. Nylon block
5. PTO belt

3. Unplug clutch electric connector.
4. Adjust the air gap so that a .015 inch feeler gauge slides in between the clutch lining and friction plate with light pressure (Fig. 33). The gap can be decreased by turning the adjusting nut clockwise (Fig. 32).
5. Rotate the clutch by hand and adjust all three air gaps. After all three gaps have been set, check all three again. Adjusting one gap can alter the other gaps.
6. Reinstall nylon block with nut and bolt. Reconnect the clutch electrical connector.

CHANGING COOLANT IN COOLING SYSTEM

The cooling system must be filled with a 50/50 solution of water and permanent ethylene glycol anti-freeze. After every two years, drain the coolant from the radiator, reservoir expansion tank and engine by opening the drain cock and block plug. After coolant is drained, flush the entire system and refill it with a 50/50 solution of water and anti-freeze. Capacity of cooling system is approximately 4 quarts. When filling, fill the radiator completely and fill the expansion tank to between the marks. DO NOT OVERFILL. Always install radiator cap securely.



CAUTION

If engine has been running, pressurized hot coolant can escape when radiator cap is removed and cause burns.

MAINTENANCE

ADJUSTING TRANSMISSION FOR NEUTRAL

The machine must not creep when traction pedal is released. If it does creep, an adjustment is required.

1. Park machine on a level surface and shut engine off. Depress only the right brake pedal and engage the parking brake.
2. Jack up left front side of machine until tire is off shop floor. Support machine with jack stands to prevent it from falling accidentally.
3. Lift seat. Visually inspect traction linkage for possible binding condition, correct if necessary and check machine operation. If condition still exists, repeat steps 1 and 2 and proceed to step 4.
4. Loosen two locknuts securing pump plate so plate is free to move (Fig. 34).
5. Start engine and rotate pump plate (Fig. 34) in either direction until wheel ceases rotation.
6. Stop engine and tighten locknuts to secure pump plate (Fig. 34).
7. Start engine and check adjustment. Repeat adjustment, if necessary.

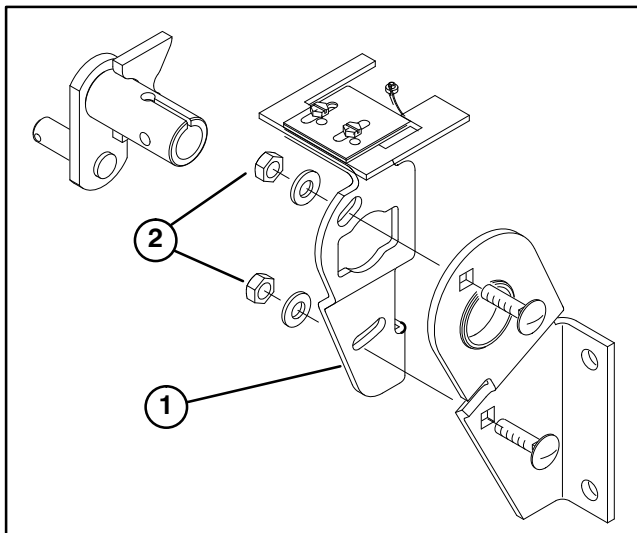

Figure 34

1. Pump plate 2. Locknuts

8. Stop the engine and release right brake. Remove jack stands and lower machine to the shop floor. Test drive the machine to be sure it does not creep.

CHANGING TRANSMISSION FILTER

Initially, replace the transmission filter after the first full day's operation — NOT TO EXCEED 10 HOURS. Replace the oil and filter every 200 hours thereafter. The hydraulic system is designed to operate on any high quality detergent oil having the American

Petroleum Institute — API — “service classification” SF/CC or CD. Oil viscosity — weight — must be selected according to anticipated ambient temperature for the season in which product will be used.

Temperature/viscosity recommendations are:

| Expected Ambient Temperature | Recommended Viscosity and Type |
|------------------------------|--|
| (Extreme) over 90° F | SAE 30, Type SF/CC or CD engine oil. |
| (Normal) 40-100° F | SAE 10W-30 or 10W-40. Type SF/CC or CD engine oil. |
| (Cool—Spring/Fall) 30-50° F | SAE 5W-30, Type SF/CC or CD engine oil. |
| (Winter) Below 30° F | Type “F” or “FA” ATF Automatic Transmission Fluid. |

Note: Do not mix engine oil and automatic transmission fluid or hydraulic component damage may result. When changing fluids, also change transmission filter. **DO NOT USE DEXRON II ATF.**

Note: Fluid to operate the power steering is supplied by the hydraulic system transmission charge pump.

Cold weather start—up may result in “stiff” operation of the steering until the hydraulic system has warmed up. Using proper weight hydraulic oil in system will minimize this condition.

The axle housing acts as the reservoir for the system. The transmission and axle housing are shipped from the factory with approximately 5 quarts of SAE 10W-30 engine oil. However, check level of transmission oil before engine is first started and daily thereafter.

1. Lower cutting unit to shop floor, set parking brake, and turn engine OFF. Block the two rear wheels.
2. Jack up both sides of the front axle and support it with jack stands.
3. Clean the area around the hydraulic oil filter and remove the filter (Fig. 35).
4. Remove the tube that connects the axle housing to the transmission and allow the oil to flow into a drain pan.
5. Install new hydraulic oil filter and connect the tube between axle housing and transmission. Fill axle (reservoir) to proper level (approx. 5 qt); refer to Check Hydraulic System Fluid. Remove jack stands.
6. Start engine, cycle steering and lift cylinders, and check for oil leaks. allow engine to run for about five minute. Then shut engine off.
7. After two minutes, check level of transmission fluid; refer to Check Hydraulic System Fluid.

MAINTENANCE

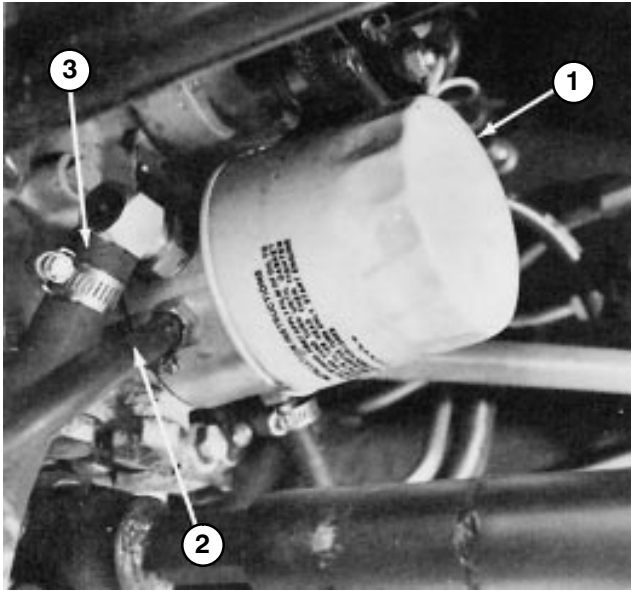

Figure 35

1. Hydraulic system filter
2. Hydraulic return lines
3. Suction line

ADJUSTING SERVICE BRAKES

Adjust the service brakes when there is more than one inch of “free travel” of the brake pedals, or when the brakes do not work effectively. Free travel is the distance the brake pedal moves before braking resistance is felt.

The brakes should be checked for adjustment after the first 50 hours of operation and should only need adjusting after considerable use thereafter. These periodic adjustments can be performed where the brake cable connect to the bottom of the brake pedals. When the cable is no longer adjustable, the star nut on inside of the brake drum must be adjusted to move the brake shoes outward. However, the brake cables must be adjusted again to compensate for this adjustment.

1. Disengage lock arm from right brake pedal so both pedals work independently of each other.

2. To reduce free travel of brake pedals — tighten the brakes — loosen front nut on threaded end of brake cable (Fig. 36). Then tighten rear nut to move cable backward until brake pedals have 1/2 to 1 inch (13 mm to 25 mm) of free travel. Tighten front nut after brakes are adjusted correctly.

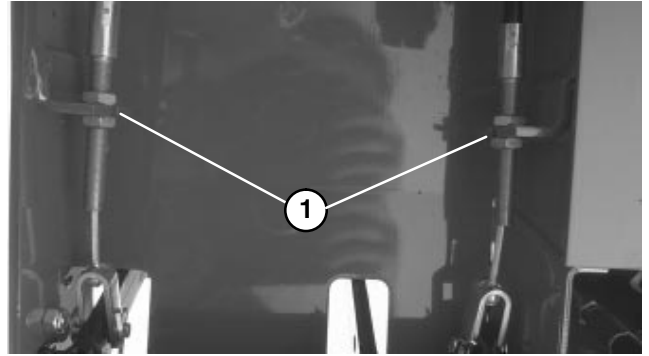

Figure 36

1. Jam nuts

SERVICING BATTERY

IMPORTANT: Before welding on the machine, disconnect ground cable from the battery to prevent damage to the electrical system.

Note: Check battery condition weekly or after every 50 hours of operation. Keep terminals and entire battery case clean because a dirty battery will slowly discharge. To clean the battery wash the entire case with solution of baking soda and water. Rinse with clear water. Coat the battery posts and cable connector with Grafo 112X (Skin-over) grease, Toro Part No. 505-47 or petroleum jelly to prevent corrosion.

WIRING HARNESS SERVICE

Prevent corrosion of wiring terminals by applying Grafo 112X (Skin-over) grease, Toro Part No. 505-47, to the inside of all harness connectors whenever the harness is replaced.

Whenever working with the electrical system, always disconnect battery cables, negative (–) cable first, to prevent possible wiring damage from short-outs.

FUSES

Fuse block is accessible under seat plate (Fig. 37).

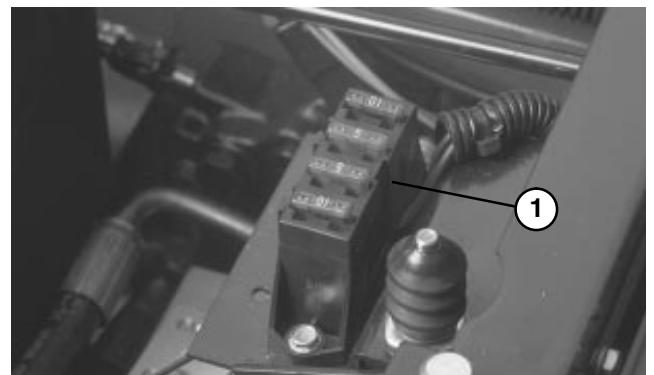
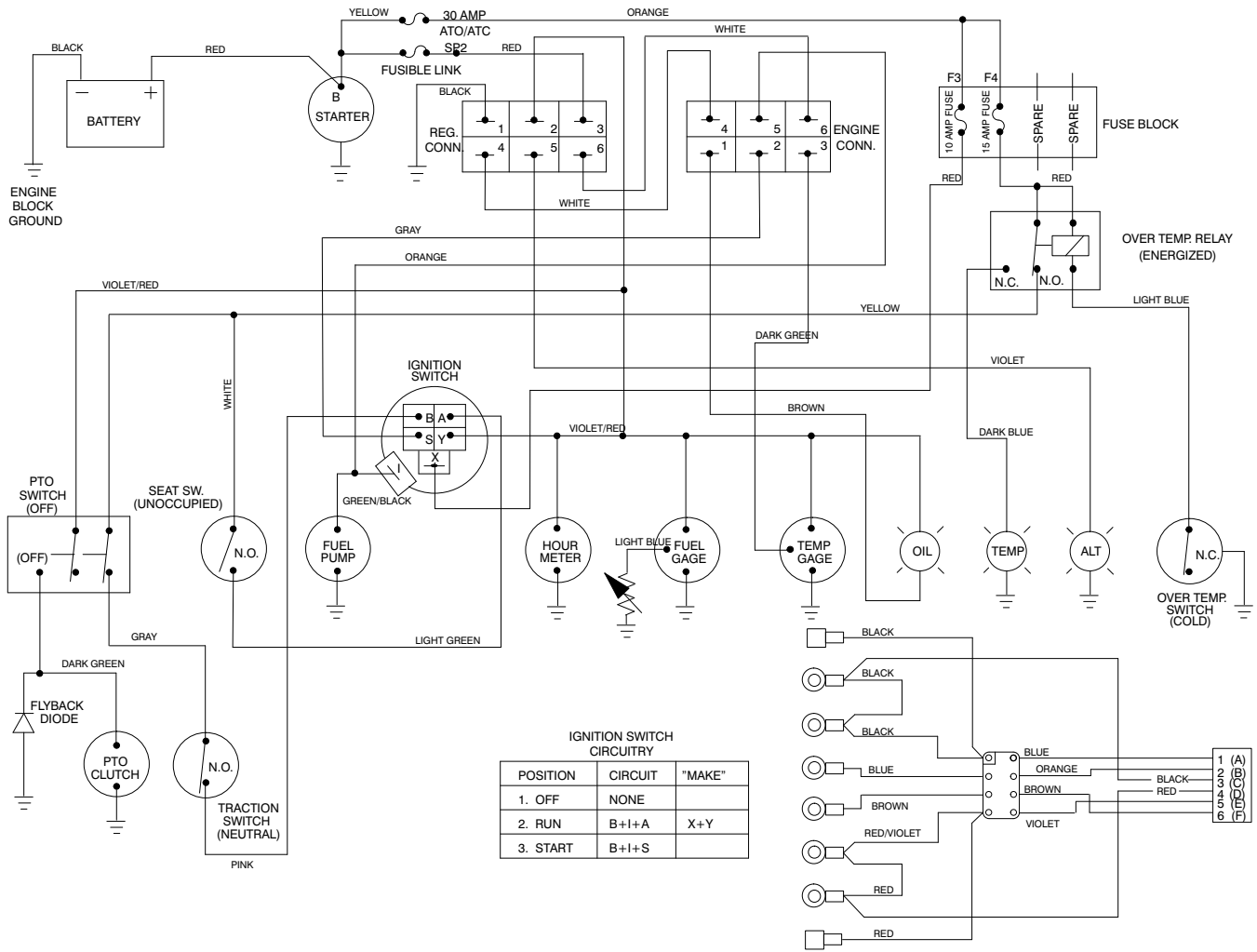

Figure 37

1. Fuse block

ELECTRICAL SCHEMATIC



HYDRAULIC SCHEMATIC

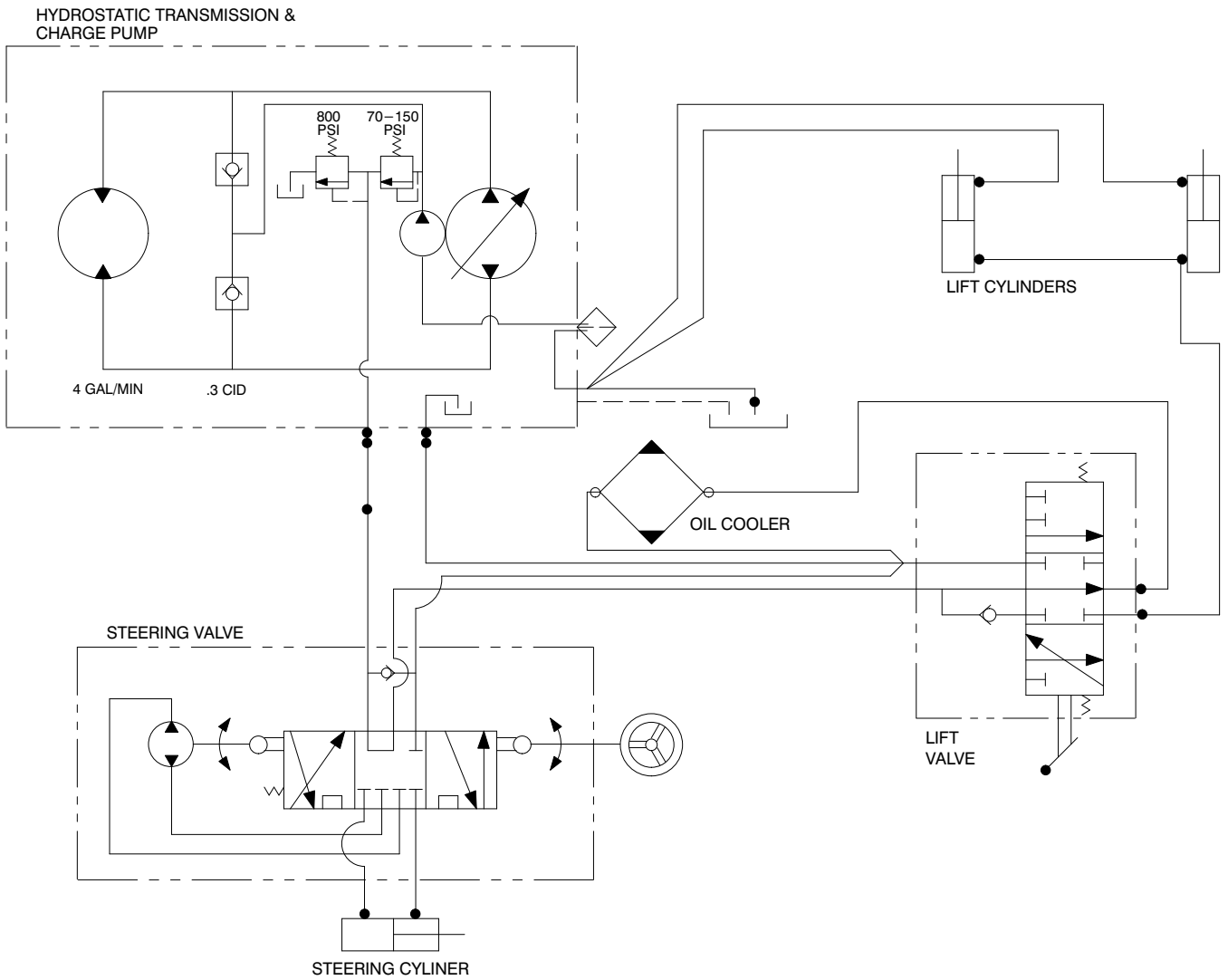

PREPARATION FOR SEASONAL STORAGE

Traction Unit

1. Thoroughly clean the traction unit, cutting unit and the engine, paying special attention to these areas:
 - radiator and radiator screen
 - underneath the cutting unit
 - under the cutting unit belt covers
 - counterbalance springs
 - P.T.O. Shaft Assembly
 - all grease fittings and pivot points
 - remove control panel and clean out inside of the control box
 - beneath seat plate and top of transmission
2. Check the tire pressure. Inflate all traction unit tires to 20 psi.
3. Remove, sharpen and balance the cutting unit's blades. Reinstall the blades and torque the blade fasteners to 85-110 ft-lb.
4. Check all fasteners for looseness; tighten as necessary.
5. Grease or oil all grease fittings, pivot points, and transmission by-pass valve pins. Wipe off any excess lubricant.
6. Lightly sand and use touch up paint on painted areas that are scratched, chipped or rusted. Repair any dents in the metal body.
7. Service the battery and cables as follows:

- a. Remove the battery terminals from the battery posts.
- b. Clean the battery, terminals and posts with a wire brush and baking soda solution.
- c. Coat the cable terminals and battery posts with Grafo 112X skin-over grease (Toro Part Number 505-47), or petroleum jelly to prevent corrosion.
- d. Slowly recharge the battery for 24 hours every 60 days to prevent lead sulfation of the battery.

Engine

1. Drain the engine oil from the oil pan and replace the drain plug.
2. Remove and discard the oil filter. Install a new filter.
3. Refill the engine with 1.6 quarts of recommended motor oil. Refer to Changing Engine Oil.
4. Start the engine and run at idle speed for two minutes.
5. Drain gasoline from the fuel tank, fuel lines, pump and filter. Flush fuel tank with clean solvent and connect all fuel lines.
6. Thoroughly clean and service the air cleaner assembly.
7. Seal the air cleaner inlet and the exhaust outlet with weather proof masking tape.
8. Check the oil filler cap and fuel tank cap to ensure they are securely in place.

PRODUCT IDENTIFICATION

The traction unit has two identification numbers: a model number and a serial number that are stamped into a plate. The identification plate is located near the left brake pedal on the frame (Fig. 38). In any correspondence concerning the traction unit, supply the model and serial numbers to ensure correct information and replacement parts are obtained.

To order replacement parts from an Authorized TORO Dealer supply the following information:

1. Model and serial numbers of the traction unit.
2. Part number, description and quantity of parts desired.

Note: Do not order by reference number if a parts catalog is being used; use the part number.

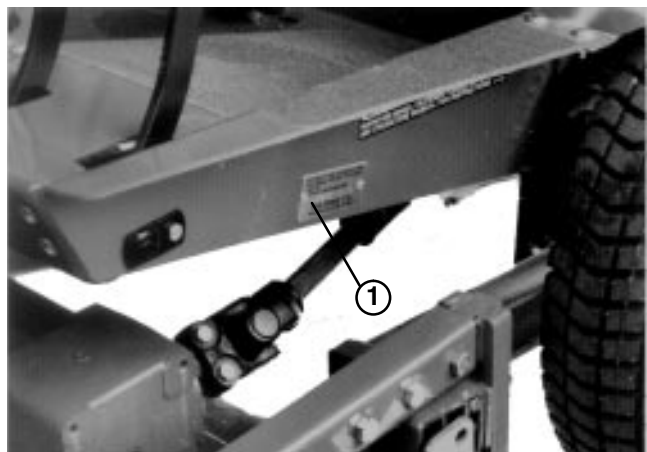

Figure 38

1. Model and serial ID plate

MAINTENANCE SCHEDULE

Minimum Recommended Maintenance Intervals

| Maintenance Procedure | Maintenance Interval & Service | | | |
|--|--------------------------------|--|-----------------|-----------------|
| <div style="border: 1px solid black; padding: 5px; margin-bottom: 5px;"> Check Battery Fluid Level Check Battery Cable Connections Lubricate All Grease Fittings Lubricate Brake Cables Check Cutting Unit Gear Box Oil Level Clean Under Cutting Unit Belt Covers Check Cutting Unit Drive Belt Adjustment ‡ Change Engine Oil Service Air Filter </div> <div style="border: 1px solid black; padding: 5px; margin-bottom: 5px;"> ‡ Change Engine Oil Filter Check Electric Clutch Gap Adjustment † Check PTO Belt Tension Inspect Cooling System Hoses </div> <div style="border: 1px solid black; padding: 5px; margin-bottom: 5px;"> Service Air Filter Replace Fuel Filte Check Rear Wheel Toe-In and Steering Linkage † Change Transmission Filter † Torque Wheel Lug Nuts </div> <div style="border: 1px solid black; padding: 5px; margin-bottom: 5px;"> Drain and Clean Fuel Tank Replace Cutting Unit Gear Box Oil Pack Rear Wheel Bearings Coat Transmission Bypass Pins with Grease ‡ Torque Head, Adjust Valves and Check Engine RPM </div> <div style="border: 1px solid black; padding: 5px; margin-bottom: 5px;"> † Initial break in at 10 hours ‡ Initial break in at 8 hours </div> <div style="border: 1px solid black; padding: 5px;"> Replace Moving Hoses Replace Safety Switches Coolant System – Flush/Replace Fluid Replace Hydraulic Oil </div> | Every 50hrs | Every 100hrs | Every 200hrs | Every 400hrs |
| | | <p>Annual Recommendations: Items listed are recommended every 1000 hours or 2 years, whichever occurs first.</p> | | |



THE TORO TOTAL COVERAGE GUARANTEE

A One-Year Limited Warranty
(A Two-Year Full Warranty for Residential Use)

What Is Covered By This Express Warranty?

The Toro Company promises to repair any TORO product used for commercial, institutional, or rental purposes if defective in materials or workmanship for a period of one year from the date of purchase. The cost of parts and labor are included, but the customer pays the transportation cost. Transportation within a 15-mile radius of a TORO ProLine Service Dealer is covered under this warranty for Riding Products, Mid-size Mowers and Turf Maintenance Equipment.

What Products Are Covered By This Warranty?

The following products and their attachments are covered by this warranty:

- Z-Master Zero Radius Tractors
- ProLine Mid-size Mowers
- Groundsmaster Riding Mowers
- ProLine Hand-held Gas Products
- Backpack Blowers
- Commercial WPM
- Turf Maintenance Equipment
- Debris Management Equipment

How About Residential Use?

TORO products used for residential use are covered by a full two-year warranty.

How Do You Get Warranty Service?

Should you feel your TORO product contains a defect in materials or workmanship, contact the dealer who sold you the product or any TORO ProLine Service Dealer. The Yellow Pages of your telephone directory is a good reference source; look under TORO Commercial Service Dealers. The Service Dealer will either arrange service at his/her dealership or recommend another authorized Service Dealer who may be more convenient. You may need proof of purchase (copy of registration card, sales receipt, etc.) for warranty validation.

If for any reason you are dissatisfied with a Service Dealer's analysis of the defect in materials or workmanship or if you need a referral to a TORO ProLine Service Dealer, please feel free to contact us at the following address:

Toro Customer Service Department
8111 Lyndale Avenue South
Bloomington, MN 55420-1196
612-888-8801 or 800-348-2424

What Must You Do To Keep The Warranty In Effect?

You must maintain your TORO Product by following the maintenance procedures described in the operator's manual. Such routine maintenance, whether performed by a dealer or by you, is at your expense.

What Does This Warranty Not Cover? and

How Does Your State Law Relate To This Warranty?

There is no other express warranty except as described above. This express warranty does not cover:

- Cost of regular maintenance service or parts, such as filters, fuel, lubricants, tune-up parts, blade sharpening, brake and clutch adjustments.
- Any product or part which has been altered or misused or required replacement or repair due to normal wear, accidents, or lack of proper maintenance.
- Repairs necessary due to improper fuel, contaminants in the fuel system, or failure to properly prepare the fuel system prior to any period of non-use over three months.
- Pickup and delivery charges for distances beyond a 15-mile radius from a TORO ProLine Service Dealer.

All repairs covered by this warranty must be performed by a TORO Service Dealer using Toro approved replacement parts.

The Toro Company is not liable for indirect or consequential damages in connection with the use of the TORO Products covered by this warranty, including any cost or expense of providing substitute equipment or service during reasonable periods of malfunction or non-use pending completion of repairs under this warranty. Some states do not allow exclusions of incidental or consequential damages, so the above exclusion may not apply to you.

This warranty gives you specific legal rights, and you may also have other rights which vary from state to state.

COUNTRIES OTHER THAN THE UNITED STATES OR CANADA

Customers who have purchased TORO products exported from the United States or Canada should contact their TORO Distributor (Dealer) to obtain guarantee policies for your country, province, or state. If for any reason you are dissatisfied with your distributor's service or have difficulty obtaining guarantee information, contact the TORO importer. If all other remedies fail, you may contact us at The Toro Company.