



Count on it.

Operator's Manual

21in Heavy-Duty Recycler[®]/Rear Bagger Lawn Mower

Model No. 22198—Serial No. 313000001 and Up

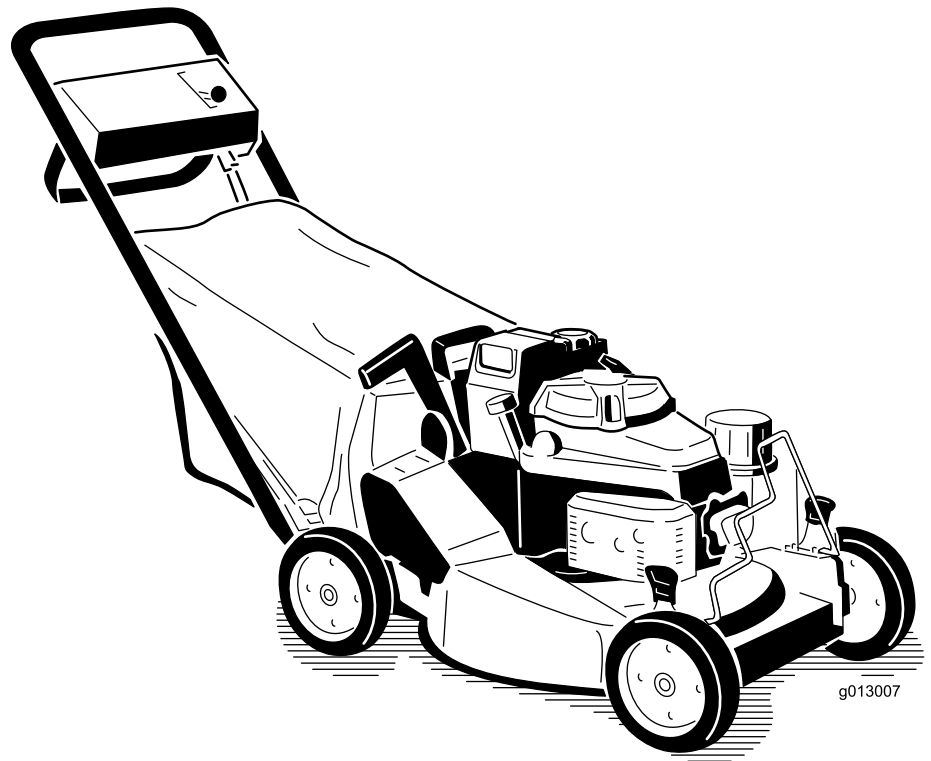

g013007



▲ WARNING

CALIFORNIA Proposition 65 Warning

This product contains a chemical or chemicals known to the State of California to cause cancer, birth defects, or reproductive harm.

The engine exhaust from this product contains chemicals known to the State of California to cause cancer, birth defects, or other reproductive harm.

Use of this product may cause exposure to chemicals known to the State of California to cause cancer, birth defects, or other reproductive harm.

Important: This engine is not equipped with a spark arrester muffler. It is a violation of California Public Resource Code Section 4442 to use or operate the engine on any forest-covered, brush-covered, or grass-covered land. Other states or federal areas may have similar laws.

This spark ignition system complies with Canadian ICES-002.

The enclosed *Engine Owner's Manual* is supplied for information regarding the US Environmental Protection Agency (EPA) and the California Emission Control Regulation of emission systems, maintenance, and warranty. Replacements may be ordered through the engine manufacturer.

Introduction

This rotary-blade, walk-behind lawn mower is intended to be used by residential homeowners or professional, hired operators. It is designed primarily for cutting grass on well-maintained lawns on residential or commercial properties. It is not designed for cutting brush or for agricultural uses.

Read this information carefully to learn how to operate and maintain your product properly and to avoid injury and product damage. You are responsible for operating the product properly and safely.

You may contact Toro directly at www.Toro.com for product and accessory information, help finding a dealer, or to register your product.

Whenever you need service, genuine Toro parts, or additional information, contact an Authorized Service Dealer or Toro Customer Service and have the model and serial numbers of your product ready. [Figure 1](#) identifies the location of the model and serial numbers on the product. Write the numbers in the space provided.

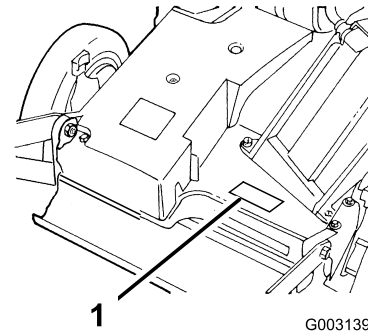

Figure 1

1. Model and serial number plate

Model No. _____

Serial No. _____

This manual identifies potential hazards and has safety messages identified by the safety alert symbol ([Figure 2](#)), which signals a hazard that may cause serious injury or death if you do not follow the recommended precautions.



Figure 2

1. Safety alert symbol

This manual uses 2 words to highlight information.

Important calls attention to special mechanical information and **Note** emphasizes general information worthy of special attention.

Contents

Safety	4
General Lawn Mower Safety	4
Training	4
Preparation.....	4
Operation.....	4
Maintenance and Storage.....	5
Safety and Instructional Decals	6
Setup	7
1 Installing the Handle	7
2 Installing the Fuel Tank.....	8
3 Installing the Discharge Tunnel Plug.....	8
4 Filling the Crankcase with Oil	9
Product Overview	10
Controls	10
Operation	11
Checking the Engine Oil Level	11
Filling the Fuel Tank	12
Starting the Engine	12
Stopping the Engine	13
Operating the Self-propel Drive and Engaging the Cutting Blade	13
Using the Discharge Tunnel Plug.....	13
Checking the Blade Brake Clutch	13
Adjusting the Cutting Height.....	15
Using the Grass Bag.....	15
Operating Tips	16
Maintenance	18
Recommended Maintenance Schedule(s)	18
Lubrication	19
Lubricating the Pivot Arms.....	19
Lubricating the Gear Case.....	19
Engine Maintenance	19
Servicing the Air Filter	19
Changing the Engine Oil	20
Changing the Oil Filter.....	20
Servicing the Spark Plug.....	21
Fuel System Maintenance	22
Emptying the Fuel Tank and Cleaning the Fuel Filter.....	22
Drive System Maintenance	22
Adjusting the Self-propel Drive	22
Controls System Maintenance	23
Adjusting the Blade Brake Cable.....	23
Blade Maintenance.....	23
Maintaining the Cutting Blade	23
Cleaning	25
Cleaning under the Machine Housing	25
Cleaning the Discharge Tunnel and Plug	25
Cleaning the Blade Brake Clutch Shield.....	26
Cleaning under the Belt Cover	26
Storage	27
Preparing the Fuel System	27
Preparing the Engine	27
General Information.....	27
Removing the Machine from Storage.....	27

Safety

This lawn mower meets the CPSC blade safety requirements for walk-behind rotary lawn mowers and the B71.4 specifications of the American National Standards Institute in effect at the time of production.

Improperly using or maintaining this lawn mower can result in injury. To reduce the potential for injury, comply with these safety instructions.

Toro designed and tested this lawn mower to offer reasonably safe service; however, **failure to comply with the following instructions may result in personal injury.**

⚠ WARNING

Engine exhaust contains carbon monoxide, an odorless, deadly poison that can kill you.

Do not run the engine indoors or in an enclosed area.

To ensure maximum safety, best performance, and to gain knowledge of the product, it is essential that you and any other operator of the lawn mower read and understand the contents of this manual before the engine is ever started. Pay particular attention to the safety alert symbol (Figure 2) which means Caution, Warning, or Danger—“personal safety instruction.” Read and understand the instruction because it has to do with safety. Failure to comply with the instruction may result in personal injury.

General Lawn Mower Safety

This lawn mower is capable of amputating hands and feet and of throwing objects. Failure to observe the following safety instructions could result in serious injury or death.

The following instructions are from the ANSI/OPEI B71.4–2004 standard.

Training

- Read the Operator’s Manual and other training material.
- If the operator(s) or mechanic(s) cannot read English it is the owner’s responsibility to explain this material to them.
- Become familiar with the safe operation of the equipment, operator controls, and safety signs.
- All operators and mechanics should be trained. The owner is responsible for training the users.
- Never let children or untrained people operate or service the equipment. Local regulations may restrict the age of the operator.
- The owner/user can prevent and is responsible for accidents or injuries occurring to themselves, other people or property.

Preparation

- Evaluate the terrain to determine what accessories and attachments are needed to properly and safely perform the job.
- Only use accessories and attachments approved by the manufacturer.
- Wear appropriate clothing, including safety glasses and hearing protection. Long hair, loose clothing or jewelry may get tangled in moving parts.
- Inspect the area where the equipment is to be used and remove all objects such as rocks, toys and wire which can be thrown by the machine.
- Use extra care when handling gasoline and other fuels.
 - They are flammable and vapors are explosive.
 - Use only an approved container.
 - Never remove gas cap or add fuel when engine is running.
 - Do not smoke.
 - Never refuel or drain the machine indoors.
- Check that operator’s presence controls, safety switches and shields are attached and functioning properly. Do not operate unless they are functioning properly.

Operation

- Never run an engine in an enclosed area.
- Only operate in good light, keeping away from holes and hidden hazards.
- Be sure all drives are in neutral before starting engine.
- Be sure of your footing while using pedestrian controlled equipment, especially when backing up.
- Walk, don’t run.
- Never operate on wet grass. Reduced footing could cause slipping.
- Slow down and use extra care on hillsides. Be sure to travel side to side on hillsides.
- Use caution while operating near drop-offs.
- Slow down and use caution when making turns and when changing directions on slopes.
- Never raise deck with the blades running.
- Do not change the engine governor setting or overspeed the engine.
- Stop equipment and inspect blades after striking objects or if an abnormal vibration occurs. Make necessary repairs before resuming operations.
- Keep hands and feet away from the cutting units.
- Look behind and down before backing up to be sure of a clear path.

- Do not operate the mower under the influence of alcohol or drugs.
- Use care when loading or unloading the machine into a trailer or truck.
- Use care when approaching blind corners, shrubs, trees, or other objects that may obscure vision.

Maintenance and Storage

- Wait for all movement to stop before adjusting, cleaning or repairing.
- Clean grass and debris from cutting unit, muffler, and engine to help prevent fires.
- Clean up oil or fuel spillage.
- Let engine cool before storing and do not store near flame.
- Do not store fuel near flames or drain indoors.
- Never allow untrained personnel to service machine.
- Use care when checking blade.
- Wrap the blade or wear gloves, and use caution when servicing.
- Only replace blade. Never straighten or weld them.
- Keep hands and feet away from moving parts.
- If possible, do not make adjustments with the engine running.
- Keep all parts in good working condition and all hardware tightened.
- Replace all worn or damaged decals.

Safety and Instructional Decals



Safety decals and instructions are easily visible to the operator and are located near any area of potential danger. Replace any decal that is damaged or lost.

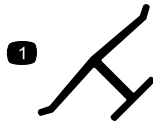

Manufacturer's Mark

1. Indicates the blade is identified as a part from the original machine manufacturer.



94-8072



68-7410



74-1970

1. Transmission speeds
2. Neutral



98-4387

1. Warning—wear hearing protection.



112-8736



117-2718

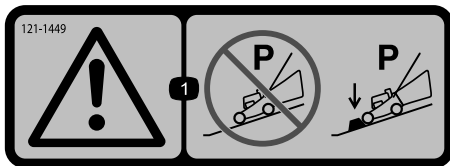

121-1449

1. Warning—do not park on slopes unless wheels are chocked or blocked.

Setup

Loose Parts

Use the chart below to verify that all parts have been shipped.

Procedure	Description	Qty.	Use
1	Handle	1	Install the handle.
	Bolt (5/16 x 1-1/4 inches)	2	
	Washer	4	
	Thin locknut (5/16 inch)	2	
	Bolt (5/16 x 1-1/2 inches)	2	
	Locknut (5/16 inch)	2	
	Bag support rod	1	
	Cap locknut	2	
	Cable tie	1	
2	Self-tapping screw	2	Install the fuel tank.
	Fuel tank	1	
3	Discharge tunnel plug	1	Install the discharge tunnel plug.
4	No parts required	–	Fill the crankcase with oil.

Note: Determine the left and right sides of the machine from the normal operating position.

1

Installing the Handle

Parts needed for this procedure:

1	Handle
2	Bolt (5/16 x 1-1/4 inches)
4	Washer
2	Thin locknut (5/16 inch)
2	Bolt (5/16 x 1-1/2 inches)
2	Locknut (5/16 inch)
1	Bag support rod
2	Cap locknut
1	Cable tie

Procedure

1. Mount the handle to the outside of the machine housing (using the bottom hole) with 2 bolts (5/16 x 1-1/4 inches), washers, and thin locknuts (5/16 inch) (Figure 3).

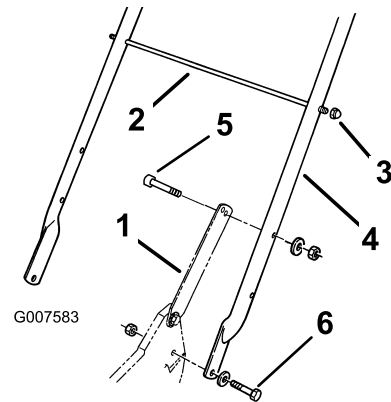

Figure 3

- | | |
|--------------------|-------------------------------|
| 1. Handle latch | 4. Handle |
| 2. Bag support rod | 5. Bolt (5/16 x 1-1/2 inches) |
| 3. Cap locknut (2) | 6. Bolt (5/16 x 1-1/4 inches) |

2. Secure the handle latches to the handle with 2 bolts (5/16 x 1-1/2 inches), washers, and locknuts (5/16 inch) (Figure 3).

Note: You can adjust the handle height for comfortable operation. Stand behind the handle to determine the height. To adjust the handle height, position the cap screws and the locknuts that secure the handle latches to the handle into the other mounting holes in the latches.

3. Slide the bag support rod through the second from the top mounting holes in the handle and secure each end with a cap locknut (Figure 3).

- Use a cable tie to secure the control cables to the left handle below the bag support rod.

2

Installing the Fuel Tank

Parts needed for this procedure:

2	Self-tapping screw
1	Fuel tank

Procedure

- Slide the plastic clips on the front of the fuel tank onto the fuel tank mount (Figure 4).

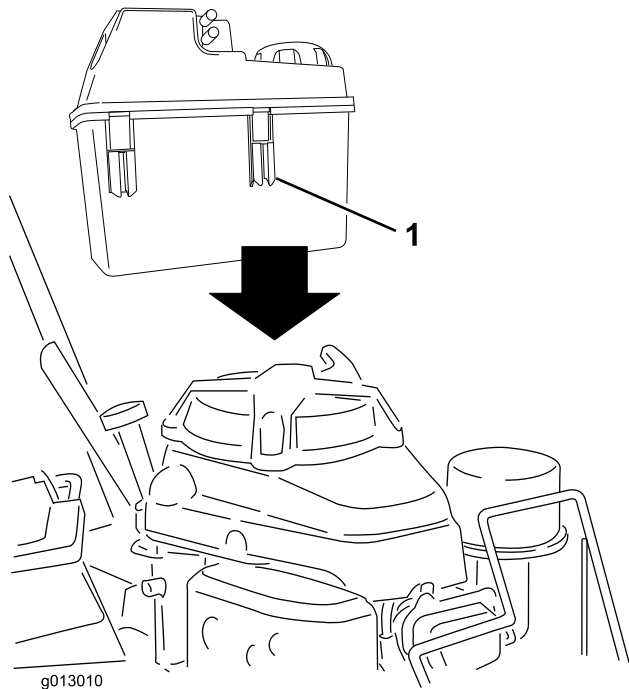

Figure 4

- Plastic clip (2)

- Secure the bottom of the fuel tank to the fuel tank bracket by installing the self-tapping screws from the bottom. **Torque the screws to 40 to 50 in-lb (4.5 to 5.6 N-m). Do not overtighten the screws.**

3

Installing the Discharge Tunnel Plug

Parts needed for this procedure:

1	Discharge tunnel plug
---	-----------------------

Procedure

- Open the discharge door by pulling forward on the handle and moving it rearward (Figure 5). Hold the discharge door handle to prevent the spring-loaded door from closing while you insert the plug.

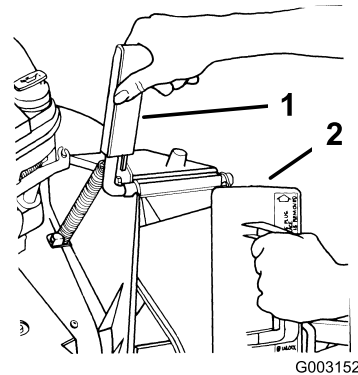

Figure 5

- Discharge door handle
- Plug, rotated clockwise

- Since the plug is slightly wider than the discharge tunnel opening, rotate the plug clockwise slightly while inserting it (Figure 5).

Note: Ensure that the arrow on the plug decal points upward.

3. Push the plug all the way in until the spring clip on the bottom of the plug clicks into place, locking the plug securely into the discharge tunnel ([Figure 6](#)).

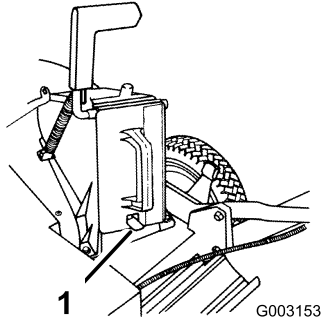

Figure 6

1. Spring clip
-

4. Release the discharge door handle to lock the top of the plug.

4

Filling the Crankcase with Oil

No Parts Required

Procedure

Important: The machine does not come with oil in the engine.

You must fill the engine crankcase with oil before starting the engine. Refer to [Checking the Engine Oil Level \(page 11\)](#) and [Changing the Engine Oil \(page 20\)](#) for oil specifications and instructions.

Product Overview

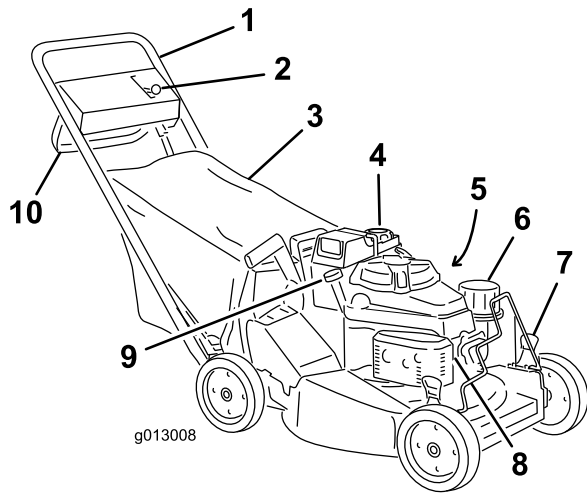

Figure 7

- | | |
|---------------------------|-------------------------|
| 1. Handle | 6. Air filter |
| 2. Throttle control lever | 7. Cutting height lever |
| 3. Grass bag | 8. Spark plug |
| 4. Fuel tank | 9. Oil fill/dipstick |
| 5. Oil filter | 10. Control bar |

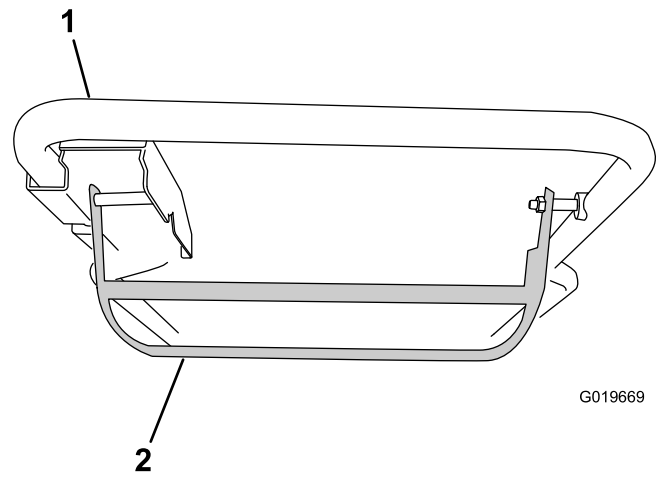

Figure 9

- | | |
|-----------|----------------|
| 1. Handle | 2. Control bar |
|-----------|----------------|

Controls

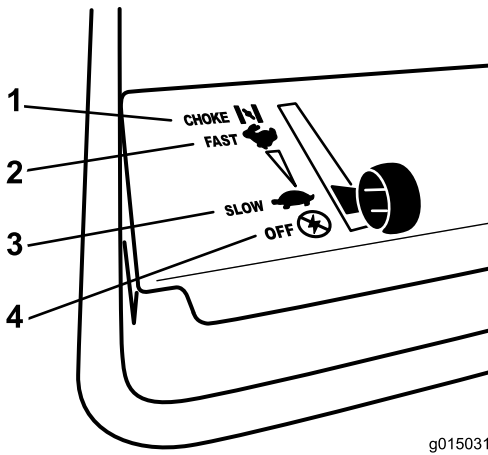

Figure 8
Throttle

- | | |
|---------|----------|
| 1. Stop | 3. Fast |
| 2. Slow | 4. Choke |

Operation

Note: Determine the left and right sides of the machine from the normal operating position.

Each time before you mow, make sure that the self-propel drive and the control bar operate properly. When you release the control bar, the blade and self-propel drive should stop. If they do not, contact an Authorized Service Dealer.

⚠ CAUTION

This machine produces sound levels in excess of 85dBA at the operator's ear and can cause hearing loss through extended periods of exposure.

Wear hearing protection when operating this machine.



Figure 10

1. Warning—wear hearing protection.

Checking the Engine Oil Level

Service Interval: Before each use or daily

The oil capacity of the crankcase (with the oil filter) is 29 ounces (0.65 liters). Use only high-quality SAE 30 or SAE 10W30 weight detergent oil that has the American Petroleum Institute (API) service classification SF, SG, SH, or SJ.

Before each use, ensure that the oil level is between the Add and Full marks on the dipstick (Figure 11).

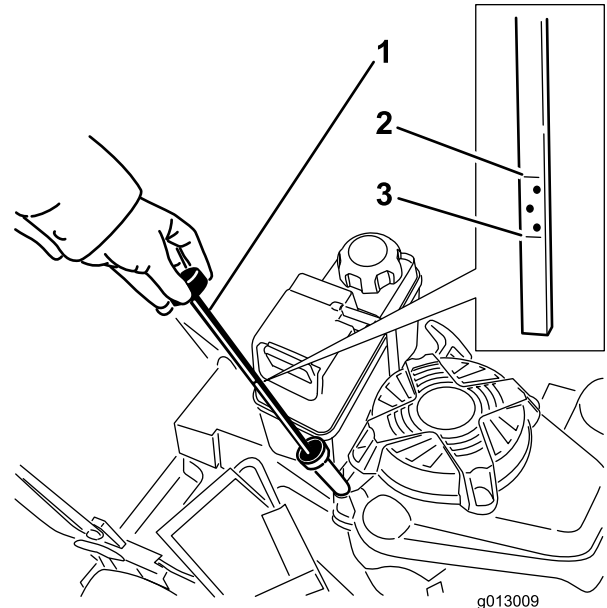

Figure 11

1. Dipstick
2. Full
3. Add

Note: When the crankcase is empty, pour about 3/4 of the crankcase capacity of oil in the crankcase, then follow the procedure in this section.

1. Move the machine to a level surface.
2. Clean around the dipstick (Figure 11).
3. Remove the dipstick by rotating the cap counterclockwise and pulling it out.
4. Wipe the dipstick clean with a clean cloth.
5. Insert the dipstick into the filler neck, then remove it.

Note: To ensure an accurate oil level reading, you must fully install the dipstick.

6. Read the oil level on the dipstick (Figure 11).
7. If the oil level reading is below the Add mark on the dipstick, slowly pour only enough oil into the filler hole to raise the oil level to the Full mark on the dipstick.

Important: Do not overfill the crankcase with oil and run the engine; engine damage will result. Drain the excess oil until the oil level on the dipstick reads Full.

8. Insert the dipstick into the filler neck and rotate the cap clockwise until it is tight.

Filling the Fuel Tank

▲ DANGER

Gasoline is extremely flammable and explosive. A fire or explosion from gasoline can burn you and others.

- To prevent a static charge from igniting the gasoline, place the container and/or machine directly on the ground before filling, not in a vehicle or on an object.
- Fill the tank outdoors when the engine is cold. Wipe up spills.
- Do not handle gasoline when smoking or around an open flame or sparks.
- Store gasoline in an approved fuel container, out of the reach of children.

Fill the fuel tank with fresh unleaded regular gasoline from a major name-brand service station.

- For best results, use only clean, fresh, unleaded gasoline with an octane rating of 87 or higher ((R+M)/2 rating method).
- Oxygenated fuel with up to 10% ethanol or 15% MTBE by volume is acceptable.
- **Do not** use ethanol blends of gasoline, such as E15 or E85, with more than 10% ethanol by volume. Performance problems and/or engine damage may result, which may not be covered under warranty.
- **Do not** use gasoline containing methanol.
- **Do not** store fuel either in the fuel tank or in fuel containers over the winter unless fuel stabilizer has been added to the fuel.
- **Do not** add oil to gasoline.

Important: To reduce starting problems, add fuel stabilizer to the fuel all season, mixing it with gasoline less than 30 days old.

1. Clean around the fuel tank cap (Figure 12).

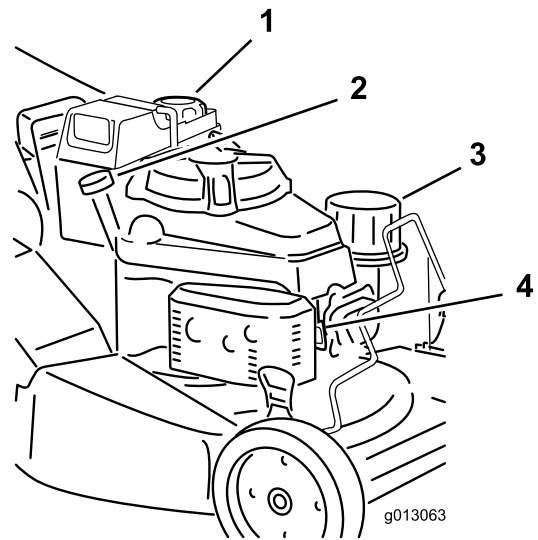

Figure 12

1. Fuel tank cap
2. Oil fill/dipstick
3. Air cleaner
4. Spark plug

2. Remove the cap from the tank.
3. Fill the fuel tank with unleaded gasoline up to the bottom of the filler neck. **Do not fill into the filler neck.**
4. Install the fuel tank cap and wipe up any spilled gasoline.

Starting the Engine

1. Connect the wire to the spark plug (Figure 12).
2. Open the fuel valve ()
3. Move the throttle control to the Choke position.
4. Move the ground speed control to the Neutral (N) position (Figure 13).

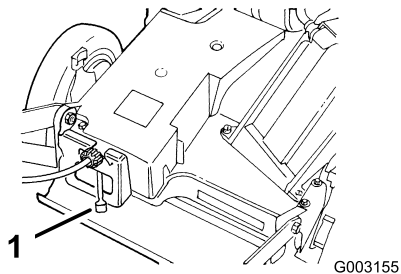

Figure 13

1. Ground speed control
5. Pull the starter handle lightly until you feel resistance, then pull it sharply.
6. Regulate the throttle and the ground speed control as desired when the engine starts.

Note: If the engine fails to start after 3 pulls, repeat steps 3 through 6.

Stopping the Engine

1. Release the control bar and move the throttle control to the Off position.
2. Disconnect the wire from the spark plug if you do not plan to use the machine or if you leave it unattended.

Operating the Self-propel Drive and Engaging the Cutting Blade

This machine is equipped with a blade brake clutch.

Important: Refer to [Checking the Blade Brake Clutch \(page 13\)](#) for important information on ensuring that the blade brake clutch is working properly.

The machine has 3 ground speeds. 1 is slow, 2 is medium, and 3 is fast. The ground speed control is located at the rear of the belt cover ([Figure 13](#)).

- To operate the self-propel drive without engaging the blade, raise the control bar to the handle ([Figure 14](#)).

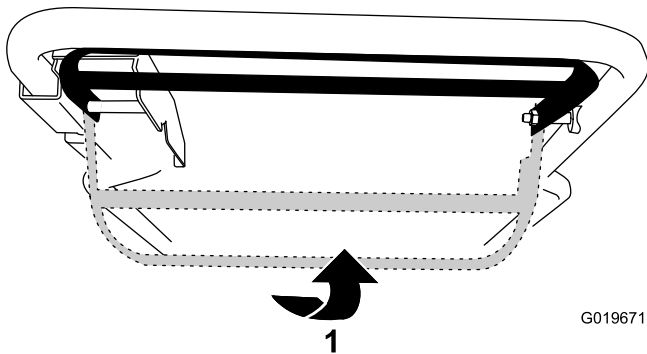

Figure 14

1. Raise the control bar to the handle.

- To operate the self-propel drive and engage the blade, slide the control bar all the way to the right and raise it to the handle ([Figure 15](#)).

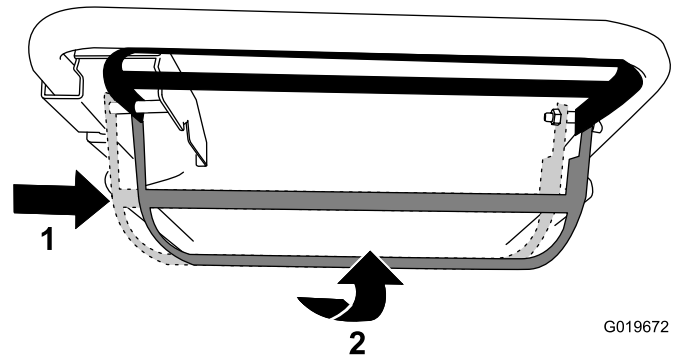

Figure 15

1. Slide the control bar to the right.
2. Raise the control bar to the handle.

- To disengage the self-propel drive and the blade, release the control bar.

Note: You can vary the ground speed by increasing or decreasing the distance between the control bar and the handle. Lower the control bar to reduce the speed when you make a turn or if the machine is moving too fast. If you lower the control bar too far, the machine stops self-propelling. Squeeze the control bar closer to the handle to increase the ground speed. When you hold the control bar tight against the handle, the machine self-propels at the maximum ground speed. Move the ground speed control to the Neutral position when you use the machine for trimming and whenever you leave the machine.

Using the Discharge Tunnel Plug

1. Stop the engine and wait for all moving parts to stop.
2. Insert the plug; refer to ([page](#)).
3. To remove the plug, move the discharge door handle rearward and lift up the spring clip on the bottom of the plug. When the plug is unlocked, pull it out of the discharge tunnel.

Note: When grass is thick and lush, clippings may collect on and around the discharge tunnel plug. This may make removing the plug difficult. Clean the plug thoroughly after each use.

Checking the Blade Brake Clutch

Check the control bar before each use to ensure that the blade brake clutch system is operating properly.

Normal Test

Service Interval: Before each use or daily

1. Stop the engine and wait for all moving parts to stop.

2. Move the machine onto a paved surface in a non-windy area.
3. Set all 4 wheels to the 2-3/4 inches (70 mm) cutting height setting; refer to [Adjusting the Cutting Height](#) (page 15).
4. Set the ground speed selector to the Neutral (N) position.
5. Take a half sheet of newspaper and crumple it into a ball small enough to go under the deck (about 3 inches or 76 mm in diameter) as shown in [Figure 16](#).

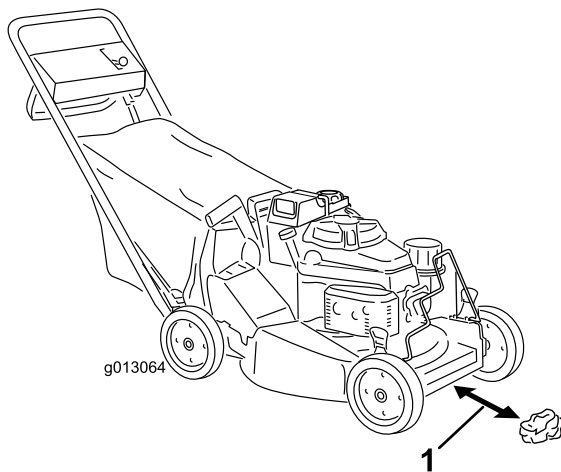

Figure 16

1. 5 inches (12.7 cm)

6. Place the ball of newspaper 5 inches (12.7 cm) in front of the machine ([Figure 16](#)).
7. Start the engine.
8. Move the control bar down to its lowest position ([Figure 17](#)).

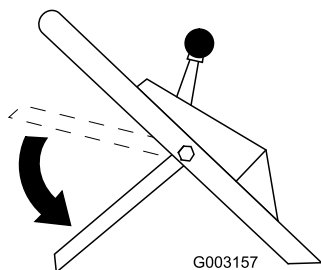

Figure 17

9. Push the control bar to the right.
10. Lift the control bar up to about 1 inch (2.5 cm) below the handle; refer to position A in [Figure 18](#).

Note: The fan-like noise indicates that the blade is turning.

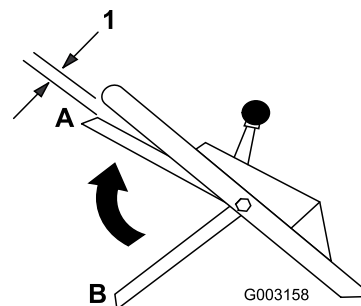

Figure 18

1. 1 inch (2.5 cm)

11. Release the control bar; refer to position B in [Figure 19](#). You should hear a “bang.” The blade should stop in 3 seconds.

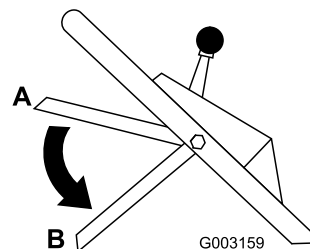

Figure 19

12. Immediately push the machine over the newspaper ball.
13. Stop the engine and wait for all moving parts to stop.
14. Walk around the machine to check for the newspaper ball. If the ball did not go under the deck, repeat steps 6 through 13.
15. Pull the machine away from the newspaper. If the newspaper ball unravels or is shredded, the blade has not properly stopped, resulting in an unsafe operating condition. Contact an Authorized Service Dealer.

To check for a problem with the blade brake clutch system before it affects its normal operation, you can perform the Special Test that follows.

Special Test

1. Follow steps 1 through 7 from the Normal Test.
2. Move the control bar down to its lowest position (Position B in [Figure 19](#)).
3. Push the control bar to the right.
4. Bring the control bar up into the middle position about 5 inches (12.7 cm) below the handle cross bar (Position C in [Figure 20](#)).

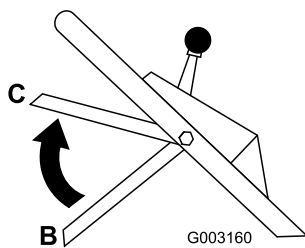

Figure 20

Note: This intermediate position (C) is not the normal operating position of the control bar. However, it helps to detect a sticking blade brake clutch system early enough to prevent an unsafe condition later.

5. Release the control bar (Position B in Figure 20).

Note: If you hear a loud “bang,” you have raised the control bar too high. Repeat steps 2 through 5 above, but do not raise the control bar as high as in step 4.

6. Immediately push the machine over the newspaper ball.
7. Stop the engine and wait for all moving parts to stop.
8. Walk around the machine to check for the newspaper ball. If the ball did not go under the deck:
 - A. Place the ball of newspaper 5 inches (12.7 cm) in front of the machine (Figure 16).
 - B. Start the engine.
 - C. Follow steps 2 through 7 above.
9. Pull the machine away from the newspaper. If the newspaper ball unravels or is shredded, the blade brake clutch system could be deteriorating to the point where it could result in an unsafe operating condition. Contact an Authorized Service Dealer for an inspection and repair of your machine.

⚠ DANGER

If the blade brake clutch system is inoperative, the blade will continue to rotate when you release the control bar. Contact with blade could occur, causing serious injury.

- Check the blade brake clutch system operation before each use.
- Never use a machine equipped with a blade brake clutch that has an inoperative safety system.
- Take your machine to an Authorized Service Dealer for repair if the safety system fails to operate properly.

Test Using the Grass Bag

You can use the grass bag to perform an additional test to check the blade brake clutch mechanism:

1. Install the empty grass bag on the discharge tunnel.

2. Start the engine.
3. Push the control bar down to its lowest position.
4. Push the control bar to the right.
5. Lift the control bar to the normal blade engaged position about 1 inch (2.5 cm) below the handle. The bag should begin to inflate, indicating that the blade is engaged and rotating.
6. Release the control bar. If the bag does not immediately deflate, it indicates that the blade is still rotating. The blade brake clutch may be deteriorating, and, if ignored, could result in an unsafe operating condition. Have the machine inspected and serviced by an Authorized Service Dealer.

Adjusting the Cutting Height

Each wheel is adjusted individually with a wheel height adjustment lever. Cutting heights are 1 inch (25 mm), 1-1/2 inches (38 mm), 2 inches (51 mm), 2-1/2 inches (64 mm), 3 inches (76 mm), and 3-1/2 inches (89 mm).

⚠ DANGER

Adjusting the cutting height levers could bring your hands into contact with a moving blade and result in serious injury.

- Stop the engine and wait for all movement to stop before adjusting the cutting height.
- Do not put your fingers under the housing when adjusting the cutting height.

1. Pull the wheel height adjustment lever toward the wheel (Figure 21) and move it to the desired setting.

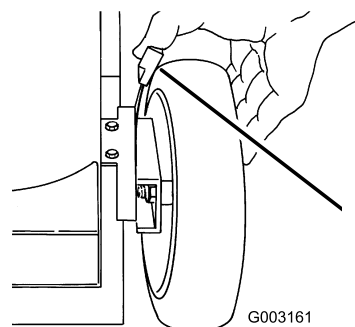

Figure 21

1. Wheel height adjustment lever
-
2. Release the wheel height adjustment lever and seat it securely in the notch.
 3. Adjust all the wheels to the same cutting height setting.

Using the Grass Bag

Occasionally, you may wish to use the grass bag for bagging extra long, lush grass, or leaves.

Installing the Grass Bag

1. Stop the engine and wait for all moving parts to stop.
2. Ensure that the discharge door handle is fully forward and that the pin is engaged in the catch (Figure 22).

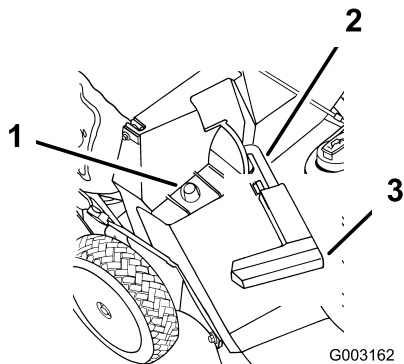

Figure 22

1. Bag frame on retaining post
2. Pin engaged in catch
3. Handle fully forward; discharge door closed

3. Slide the hole in the bag frame onto the retaining post on the discharge tunnel (Figure 22).
4. Set the rear of the bag frame onto the bag support rod.
5. Pull the discharge door handle forward until the pin clears the catch, and move the handle rearward until the pin locks in the bag notch (Figure 23).

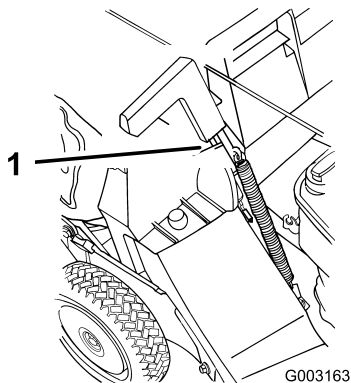

Figure 23

1. Pin locked in bag notch

Note: The discharge door in the machine housing is now open.

Mowing with the Grass Bag

⚠ WARNING

A worn grass bag could allow small stones and other similar debris to be thrown in the operator's or bystanders' direction and result in serious personal injury or death to the operator or bystanders.

Check the grass bag frequently. If it is damaged, install a new Toro replacement bag.

Removing the Grass Bag

1. Stop the engine and wait for all moving parts to stop.
2. Raise the discharge door handle and move it forward to engage the pin with the catch (Figure 22).
3. Grasp the handles at the front and the rear of the bag and lift the bag off the machine.
4. Gradually tip the bag forward to empty the clippings.
5. To install the bag, refer to [Installing the Grass Bag](#) (page 16).

⚠ DANGER

If the discharge door does not close completely, the machine could throw objects, causing serious personal injury or death.

If you cannot close the door because the grass clippings clog the discharge area, stop the engine and gently move the discharge door handle back and forth until you can close the door completely. If you still cannot close the door, remove the obstruction with a stick, not your hand.

⚠ DANGER

The machine can throw grass clippings and other objects through an open discharge tunnel. Objects thrown with enough force could cause serious personal injury or death to the operator or bystander.

Never open the door on the discharge tunnel when the engine is running.

Operating Tips

General Tips

- Review the safety instructions and read this manual carefully before operating the machine.
- Clear the area of sticks, stones, wire, branches, and other debris that the blade could hit and throw.
- Keep everyone, especially children and pets, away from the area of operation.

- Avoid striking trees, walls, curbs, or other solid objects. Never deliberately mow over any object.
- If the machine strikes an object or starts to vibrate, immediately stop the engine, disconnect the wire from the spark plug, and examine the machine for damage.
- Maintain a sharp blade throughout the cutting season. Periodically file down nicks on the blade.
- Replace the blade when necessary with an original Toro replacement blade.
- Mow only dry grass or leaves. Wet grass and leaves tend to clump on the yard and can cause the machine to plug or the engine to stall.

⚠ WARNING

Wet grass or leaves can cause serious injury if you slip and contact the blade.

Mow only in dry conditions.

- Clean under the machine housing after each mowing. Refer to [Cleaning under the Machine Housing \(page 25\)](#).
- Keep the engine in good running condition.
- Set the engine speed to the fastest position for the best cutting results.

⚠ WARNING

Operating the machine with its engine running at a speed greater than the factory setting can cause the machine to throw a part of the blade or engine into the operator's or bystander's area and result in serious personal injury or death.

- **Do not change the engine speed setting.**
- **If you suspect the engine speed is faster than normal, contact an Authorized Service Dealer.**

- Clean the air filter frequently. Mulching stirs up more clippings and dust which clogs the air filter and reduces engine performance.

Cutting Grass

- Grass grows at different rates at different times of the year. In the summer heat, it is best to cut grass at the 2-1/4 inch (57 mm), 2-3/4 inch (70 mm), or 3-1/4 inch (83 mm) cutting height settings. Cut only about a third of the grass blade at a time. Do not cut below the 2-1/4 inch (57 mm) setting unless the grass is sparse or it is late fall when grass growth begins to slow down.
- When cutting grass over 6 inches (15 cm) tall, first mow at the highest cutting height setting and walk slower; then mow again at a lower setting for the best lawn appearance.

If the grass is too long and the leaves clump on top of the lawn, the machine may plug and cause the engine to stall.

- Alternate the mowing direction. This helps disperse the clippings over the lawn for even fertilization.

If the finished lawn appearance is unsatisfactory, try one or more of the following:

- Sharpen the blade.
- Walk at a slower pace while mowing.
- Raise the cutting height on your machine.
- Cut the grass more frequently.
- Overlap cutting swaths instead of cutting a full swath with each pass.
- Set the cutting height on the front wheels one notch lower than the rear wheels. For example, set the front wheels at 2-1/4 inches (57 mm) and the rear wheels at 2-3/4 inches (70 mm).

Cutting Leaves

- After cutting the lawn, ensure that half of the lawn shows through the cut leaf cover. You may need to make more than one pass over the leaves.
- For light leaf coverage, set all the wheels at the same cutting height setting.
- If there are more than 5 inches (12.7 cm) of leaves on the lawn, set the front cutting height 1 or 2 notches higher than the rear cutting height. This makes it easier to feed the leaves under the machine housing.
- Slow down your mowing speed if the machine does not cut the leaves finely enough.
- If you mow over oak leaves, you can add lime to the grass in the spring to reduce the acidity of the oak leaves.

Maintenance

Note: Determine the left and right sides of the machine from the normal operating position.

Recommended Maintenance Schedule(s)

Maintenance Service Interval	Maintenance Procedure
After the first 8 hours	<ul style="list-style-type: none">• Change the engine oil without the oil filter.
Before each use or daily	<ul style="list-style-type: none">• Check the engine oil level.• Check the operation of the blade brake clutch.• Inspect the blades for wear or damage.• Clean under the machine housing.• Clean the discharge tunnel and plug.
Every 25 hours	<ul style="list-style-type: none">• Lubricate the pivot arms.• Clean the foam pre-cleaner (more frequently in dusty conditions).
Every 50 hours	<ul style="list-style-type: none">• Change the engine oil (more often in dusty conditions).• Check the fuel hose and replace it if necessary.• Clean the blade brake clutch shield.
Every 100 hours	<ul style="list-style-type: none">• Lubricate the gear case.• Clean the air cooling fins.• Change the oil filter.• Check the spark plug.• Clean the fuel filter.• Adjust the self-propel drive.• Adjust the blade brake cable.• Clean under the belt cover.
Every 300 hours	<ul style="list-style-type: none">• Replace the paper air filter (more frequently in dusty conditions).
Yearly or before storage	<ul style="list-style-type: none">• Empty the fuel tank.

Important: Refer to your *Engine Operator's Manual* for additional maintenance procedures.

▲ CAUTION

If you leave the wire on the spark plug, someone could accidentally start the engine and seriously injure you or other bystanders.

Disconnect the wire from the spark plug before you do any maintenance. Set the wire aside so that it does not accidentally contact the spark plug.

Lubrication

Lubricating the Pivot Arms

Service Interval: Every 25 hours

1. Move the rear wheel cutting height levers to the center setting.
2. Wipe the grease fittings with a clean rag (Figure 24).

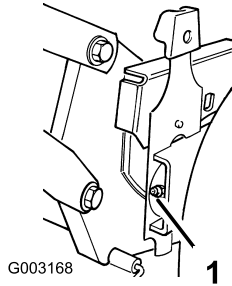

Figure 24

1. Grease fitting

-
3. Install a grease gun onto the fitting and gently apply 2 or 3 pumps of #2 multipurpose lithium-base grease.

Important: Excessive grease pressure may damage the seals.

Lubricating the Gear Case

Service Interval: Every 100 hours

1. Remove the grass bag.
2. Install a grease gun onto the fitting through the belt cover opening (Figure 25).

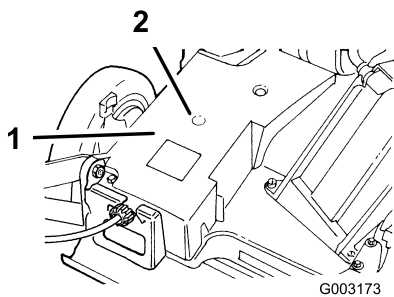

Figure 25

1. Belt cover
2. Grease fitting

-
3. Gently apply 1 to 2 pumps of #2 multipurpose lithium-base grease.
 4. Install the grass bag.

Engine Maintenance

Servicing the Air Filter

Service Interval: Every 25 hours—Clean the foam pre-cleaner (more frequently in dusty conditions).

Every 300 hours—Replace the paper air filter (more frequently in dusty conditions).

Important: Do not operate the engine without the air filter assembly; extreme engine damage will occur.

1. Stop the engine and wait for all moving parts to stop.
2. Disconnect the wire from the spark plug (Figure 12).
3. Remove the cover and clean it thoroughly (Figure 26).

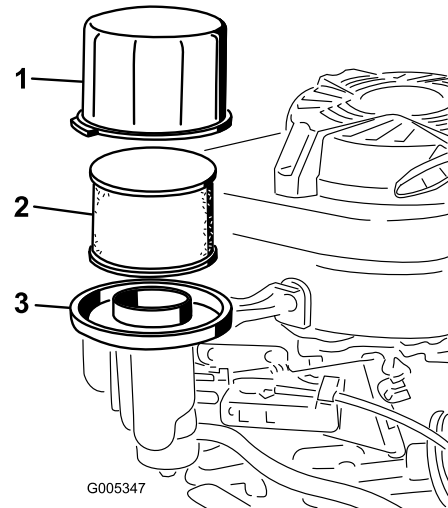

Figure 26

1. Cover
2. Paper air filter
3. Air filter base

-
4. Remove and inspect the paper air filter (Figure 26), and discard it if it is excessively dirty.

Important: Do not try to clean a paper filter.

5. Remove the foam pre-cleaner and wash it with a mild detergent and water, then blot it dry (Figure 26).
6. Install the foam pre-cleaner onto the paper air filter.
7. Install the air filter assembly.

Note: Install a new paper air filter if you discarded the old one.

8. Install the cover.

Changing the Engine Oil

Service Interval: After the first 8 hours—Change the engine oil without the oil filter.

Every 50 hours

Oil Capacity	
With oil filter	29 ounces (0.85 L)
Without oil filter	22 ounces (0.65 L)

1. Run the engine to warm the engine oil.

Note: Warm oil flows better and carries more contaminants.

⚠ WARNING

Oil may be hot after engine has been run, and contact with hot oil can cause severe personal injury.

Avoid contacting the hot engine oil when you drain it.

2. Stop the engine and wait for all moving parts to stop.
3. Disconnect the wire from the spark plug (Figure 12).
4. Drain the gasoline from the fuel tank; refer to [Emptying the Fuel Tank and Cleaning the Fuel Filter](#) (page 22).
5. Place a suitable drain pan under the right side of the machine.
6. Remove the dipstick by rotating the cap counterclockwise and pulling it out.
7. Tip the machine with the dipstick down to drain the oil into the drain pan.
Note: You can also remove the oil from the crankcase using an oil extractor.
8. Return the machine to the upright position.
9. Recycle the used oil according to local codes.
10. Fill the crankcase to the Full line on the dipstick with fresh oil. Refer to [Changing the Engine Oil](#) (page 20).
11. Insert the dipstick into the filler neck and rotate the cap clockwise until it is tight.
12. Wipe up any spilled oil.

Changing the Oil Filter

Service Interval: Every 100 hours

1. Run the engine to warm the oil.

⚠ WARNING

Oil may be hot after the engine has been run, and contact with hot oil can cause severe personal injury.

Avoid contacting the hot engine oil when you drain it.

2. Stop the engine and wait for all moving parts to stop.
3. Disconnect the wire from the spark plug (Figure 12).
4. Drain the gasoline from the fuel tank; refer to [Emptying the Fuel Tank and Cleaning the Fuel Filter](#) (page 22).
5. Drain the engine oil; refer to [Changing the Engine Oil](#) (page 20).
6. Place a rag under the oil filter to catch any oil that may leak out as you remove the filter (Figure 27).

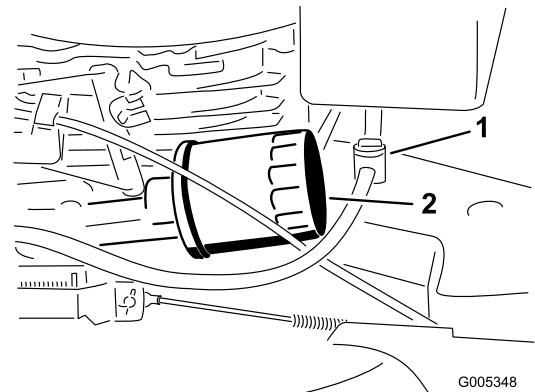

Figure 27

1. Fuel valve
2. Oil filter

7. Remove the oil filter.
8. Use your finger to coat the gasket on the new filter with oil (Figure 28).

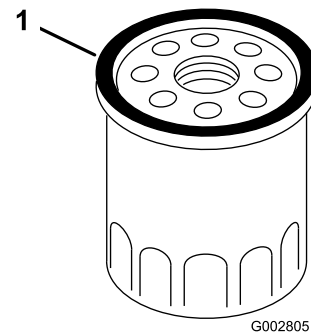

Figure 28

1. Gasket

9. Install the new filter and hand tighten it 2/3 turn after the filter gasket makes contact.
10. Fill the crankcase to the Full line on the dipstick with fresh oil; refer to [Changing the Engine Oil \(page 20\)](#).
11. Connect the wire to the spark plug.
12. Run the engine for about 3 minutes.
13. Stop the engine, wait for all moving parts to stop, and check for oil leakage around the filter.
14. Add oil to compensate for the oil in the oil filter; refer to [Checking the Engine Oil Level \(page 11\)](#).
15. Recycle the used oil filter according to local codes.

Servicing the Spark Plug

Service Interval: Every 100 hours—Check the spark plug.

Use an **NGK BPR5ES** spark plug or equivalent.

1. Stop the engine and wait for all moving parts to stop.
2. Disconnect the wire from the spark plug ([Figure 12](#)).
3. Clean around the spark plug.
4. Remove the spark plug from the cylinder head.

Important: Replace a cracked, fouled, or dirty spark plug. Do not clean the electrodes because grit entering the cylinder can damage the engine.

5. Set the gap on the plug to 0.030 in. (0.76 mm) ([Figure 29](#)).

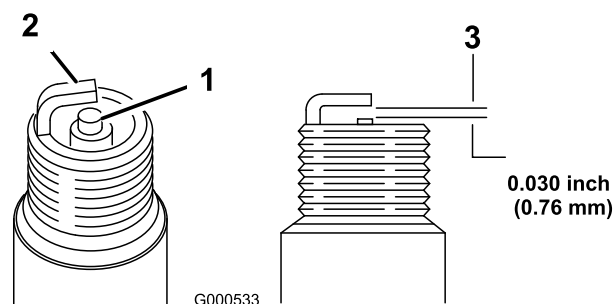

Figure 29

1. 0.030 inches (0.76 mm)

-
6. Install the spark plug and the gasket seal.
 7. Torque the plug to 17 ft-lb (23 N-m).
 8. Connect the wire to the spark plug.

Fuel System Maintenance

Emptying the Fuel Tank and Cleaning the Fuel Filter

Service Interval: Every 50 hours—Check the fuel hose and replace it if necessary.

Every 100 hours—Clean the fuel filter.

Yearly or before storage—Empty the fuel tank.

The fuel filter (screen) element is located inside the fuel tank. Clean the fuel filter element every 100 operating hours.

1. Stop the engine and wait for it to cool down.

Important: Drain gasoline from a cold engine only.

2. Disconnect the wire from the spark plug (Figure 12).
3. Close the fuel valve (Figure 27).
4. Disconnect the fuel line by loosening the tube clamp at the carburetor.
5. Open the fuel valve.
6. Drain the gasoline completely from the tank and fuel line into an approved fuel container.
7. Remove the fuel tank from the machine.
8. Close the fuel valve.
9. Pour a small amount of fuel in the fuel tank, move the fuel around in the tank, and pour it out into an approved fuel container.
10. Install the fuel tank and fuel line; refer to [2 Installing the Fuel Tank \(page 8\)](#).

Drive System Maintenance

Adjusting the Self-propel Drive

Service Interval: Every 100 hours

If the machine does not self-propel or has a tendency to creep forward when the control bar is more than 1-1/2 inches (3.8 cm) from the handle, adjust the wheel drive control knob on the rear of the gear box.

1. Close the door in the machine housing and remove the grass bag.
2. Rotate the control knob clockwise a half turn if the machine does not self-propel. If the machine creeps forward, rotate the knob a half turn counterclockwise to loosen the belt (Figure 30).

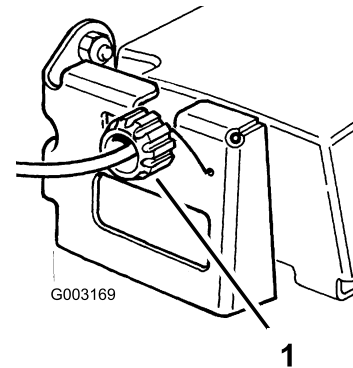

Figure 30

1. Control knob

3. Slowly pull the machine backward while you gradually move the control bar toward the handle.

Note: The adjustment is correct when the rear wheels stop turning and the control bar is about 1 inch (2.5 cm) from the handle (Figure 31).

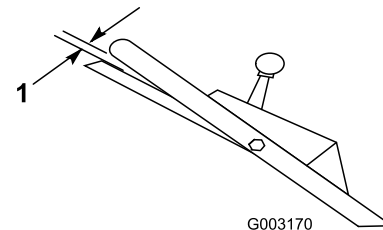

Figure 31

1. 1 inch (2.5 cm)

Controls System Maintenance

Adjusting the Blade Brake Cable

Service Interval: Every 100 hours

Whenever you install a new blade brake cable assembly or replace the belt, adjust the blade brake cable.

1. Stop the engine and wait for all moving parts to stop.
2. Disconnect the wire from the spark plug (Figure 12).
3. Loosen the cable clamp screw until the brake cable conduit slides (Figure 32).

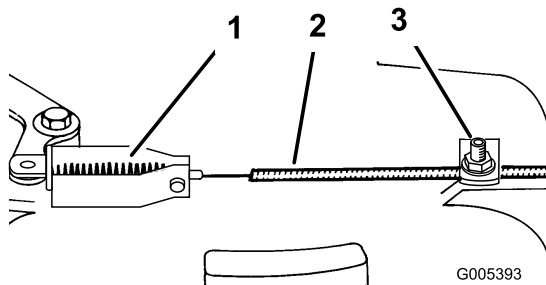

Figure 32

1. Spring
2. Cable conduit
3. Cable clamp screw and washer

4. Pull the cable to the remove slack, but do not put tension on the spring. Tighten the cable clamp screw to lock the adjustment in place.

⚠ WARNING

Do not overtighten the blade brake cable. Overtightening the blade brake cable could cause the blade brake to come off of the brake drum. If the brake does not contact the drum, the blade will not stop rotating when you release the control bar. A rotating blade could cause serious personal injury.

- Each time you adjust the brake cable, ensure that the brake stops the blade in 3 seconds or less.
- If the blade does not stop rotating in 3 seconds or less, bring the machine to an Authorized Service Dealer for inspection and repair.

Blade Maintenance

Maintaining the Cutting Blade

Always mow with a sharp blade. A sharp blade cuts cleanly and without tearing or shredding the grass blades.

1. Stop the engine and wait for all moving parts to stop.
2. Disconnect the wire from the spark plug (Figure 12).
3. Drain the gasoline from the fuel tank; refer to [Emptying the Fuel Tank and Cleaning the Fuel Filter](#) (page 22).
4. Tip the machine with the dipstick down (Figure 33).

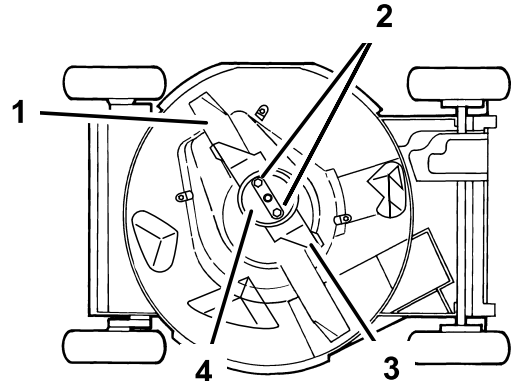

Figure 33

1. Blade
2. Blade nuts
3. Accelerator
4. Anti-scalp cup

Inspecting the Blade

Service Interval: Before each use or daily

Carefully examine the blade for sharpness and wear, especially where the flat and the curved parts meet (Figure 34A). Because sand and abrasive material can wear away the metal that connects the flat and curved parts of the blade, check the blade before using the machine. If you notice a slot or wear (Figure 34B and Figure 34C), replace the blade; refer to [Removing the Blade](#) (page 24).

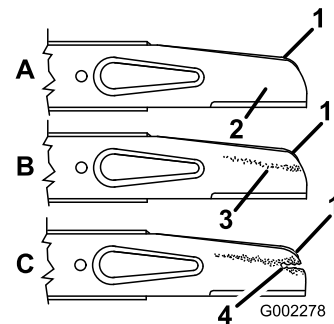

Figure 34

1. Sail
2. Flat part of the blade
3. Wear
4. Slot formed

Note: For the best performance, install a new blade before the cutting season begins. During the year, file down any small nicks to maintain the cutting edge.

⚠ DANGER

A worn or damaged blade can break, and a piece of the blade could be thrown into the operator's or bystander's area, resulting in serious personal injury or death.

- Inspect the blade periodically for wear or damage.
- Replace a worn or damaged blade.

Removing the Blade

Grasp the end of the blade using a rag or a thickly padded glove. Remove the blade nuts, the anti-scalp cup, the accelerator, and the blade (Figure 33).

Sharpening the Blade

File the top side of the blade to maintain its original cutting angle (Figure 35A) and inner cutting edge radius (Figure 35B). The blade will remain balanced if you remove the same amount of material from both cutting edges.

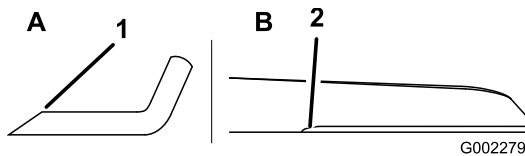

Figure 35

1. Sharpen at this angle only.
2. Maintain the original radius here.

Balancing the Blade

1. Check the balance of the blade by placing the center hole of the blade over a nail or screwdriver shank clamped horizontally in a vise (Figure 36).

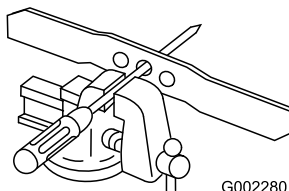

Figure 36

Note: You can also check the balance using a commercially manufactured blade balancer.

2. If either end of the blade rotates downward, file that end (not the cutting edge or the end near the cutting edge). The blade is properly balanced when neither end drops.

Installing the Blade

1. Install a sharp, balanced Toro blade, the accelerator, the anti-scalp cup, and the blade nuts. The sail of the blade must point toward the top of the machine housing for proper installation. Torque the blade nuts to 15 to 27 ft-lb (20 to 37 N-m).

⚠ WARNING

Operating the machine without the accelerator in place can cause the blade to flex, bend, or break, resulting in serious injury or death to the operator or bystanders.

Do not operate the machine without the accelerator.

2. Return the machine to its upright position.
3. Connect the wire to the spark plug.

Cleaning

Cleaning under the Machine Housing

To ensure the best performance, keep the underside of the machine housing clean. Be especially careful to keep the kickers free of debris (Figure 37).

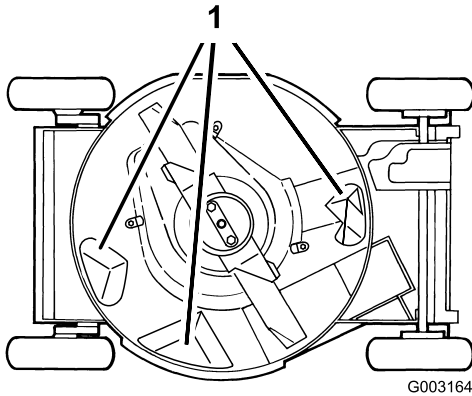

Figure 37

1. Kickers

Washing Method

Service Interval: Before each use or daily

1. Position the machine on a flat concrete or asphalt surface near a garden hose.
2. Start the engine.
3. Hold the running garden hose at handle level and direct the water to flow on the ground just in front of the **right rear tire** (Figure 38).

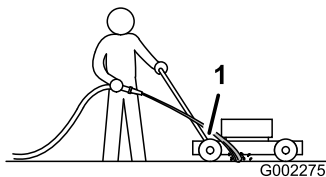

Figure 38

1. Right rear wheel

Note: The blade will draw in water and wash out clippings. Let the water run until you no longer see clippings being washed out from under the housing.

4. Stop the engine and wait for all moving parts to stop.
5. Turn off the water.
6. Start the machine and let it run for a few minutes to dry out the moisture on the machine and its components.

Scraping Method

If washing does not remove all debris from under the machine, scrape it clean.

1. Disconnect the wire from the spark plug (Figure 12).
2. Drain the fuel from the fuel tank. Refer to [Emptying the Fuel Tank and Cleaning the Fuel Filter](#) (page 22).

⚠ WARNING

Tipping the machine may cause the fuel to leak from the carburetor or the fuel tank. Gasoline is extremely flammable, highly explosive, and, under certain conditions, can cause personal injury or property damage.

Avoid fuel spills by running the engine dry or by removing the gasoline with a hand pump; never siphon.

3. Tip the machine onto its right side.
4. Remove the dirt and grass clippings with a hardwood scraper. Avoid burrs and sharp edges.
5. Turn the machine upright.
6. Fill the fuel tank.
7. Connect the wire to the spark plug.

Cleaning the Discharge Tunnel and Plug

Service Interval: Before each use or daily

Remove the plug from the discharge tunnel and clean it after each use.

Always be sure that the discharge tunnel door closes securely when you release the handle. If the debris prevents the discharge door from closing securely, clean the inside of the discharge tunnel and the door thoroughly.

⚠ WARNING

Grass clippings and other objects can be thrown from an open discharge tunnel and cause serious injury or kill the operator or bystanders.

Never start or operate the machine unless one of the following is true:

- The discharge tunnel plug is locked securely in the discharge tunnel.
- The grass bag is locked in place.
- The optional side discharge chute is locked in place.
- The discharge tunnel door is locked in place.

Cleaning the Blade Brake Clutch Shield

Service Interval: Every 50 hours

Clean the blade brake clutch shield at the end of each mowing season to ensure the best performance and to prevent parts from degrading. Clean the blade brake clutch shield when you sharpen the blade because you need to remove the blade in order to remove the blade brake clutch shield.

1. Stop the engine and wait for all moving parts to stop.
2. Disconnect the wire from the spark plug (Figure 12).
3. Drain the gasoline from the fuel tank; refer to [Emptying the Fuel Tank and Cleaning the Fuel Filter](#) (page 22).
4. Tip the machine on its **right** side.

⚠ WARNING

Tipping the machine may cause the fuel to leak from the carburetor or the fuel tank. Gasoline is extremely flammable, highly explosive, and, under certain conditions, can cause personal injury or property damage.

Avoid fuel spills by emptying the fuel tank as directed; never siphon.

5. Remove 2 blade nuts, the anti-scalp cup, the accelerator, and the blade (Figure 33).
6. Loosen the tabs that secure the blade brake clutch shield to the deck by loosening the nuts or the bolts on the tabs (Figure 39). Rotate the tabs 180° to move them out of the way.

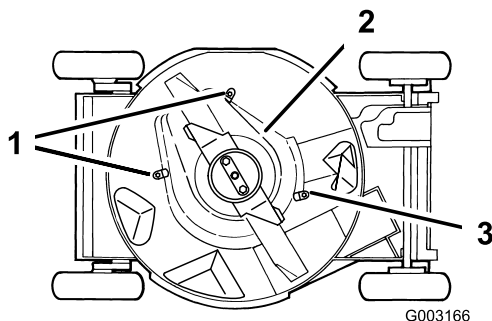

Figure 39

1. Tabs and nuts
2. Blade brake clutch shield
3. Tab and bolt

7. Remove the blade brake clutch shield and brush or blow all the debris from under the shield and around the blade brake clutch system.
8. Install the blade brake clutch shield. Rotate the tabs 180° back into position. Tighten the nuts or the bolts on tabs to secure the blade brake clutch shield to the deck.

9. Install the blade, the accelerator, the anti-scalp cup, and the 2 blade nuts.
10. Turn the machine upright.
11. Connect the wire to the spark plug.

Cleaning under the Belt Cover

Service Interval: Every 100 hours

Keep the area under the belt cover free of debris.

1. Stop the engine and wait for all moving parts to stop.
2. Remove the bolts that secure the belt cover (Figure 40) to the machine housing.

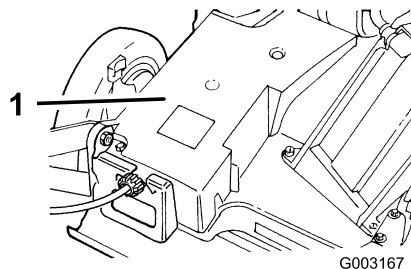

Figure 40

1. Belt cover
3. Lift off the cover and brush out all the debris around the belt area.
4. Install the belt cover.

Storage

To prepare the machine for off-season storage, perform the recommended maintenance procedures. Refer to [Maintenance \(page 18\)](#).

Store the machine in a cool, clean, dry place. Cover the machine to keep it clean and protected.

Preparing the Fuel System

⚠ WARNING

Gasoline can vaporize if you store it over long periods of time and explode if it comes into contact with an open flame.

- Do not store gasoline over long periods of time.
- Do not store the machine with gasoline in the fuel tank or the carburetor in an enclosure with an open flame. (For example, a furnace or a water heater pilot light.)
- Allow the engine to cool before storing it in any enclosure.

Empty the fuel tank when mowing the last time before storing the machine.

1. Run the machine until the engine stops from running out of fuel.
2. Choke the engine and start it again.
3. Allow the engine to run until it stops. When you can no longer start the engine, it is sufficiently dry.

Preparing the Engine

1. While the engine is still warm, change the oil from the crankcase. Refer to [Changing the Engine Oil \(page 20\)](#).
2. Remove the spark plug ([Figure 12](#)).
3. Using an oil can, add about one tablespoon of oil to the crankcase through the spark plug hole.
4. Slowly rotate the engine several times, using the starter rope, to distribute the oil.
5. Install the spark plug but do not connect the wire to the spark plug.

General Information

1. Clean the machine housing. Refer to [Cleaning under the Machine Housing \(page 25\)](#).
2. Clean any dirt and chaff from the cylinder, cylinder head fins, and blower housing.
3. Remove grass clippings, dirt, and grime from the external parts of the engine, the shrouding, and the top of the machine housing.

4. Check the condition of the blade. Refer to [Maintaining the Cutting Blade \(page 23\)](#).
5. Clean the blade brake clutch shield; refer to [Cleaning the Blade Brake Clutch Shield \(page 26\)](#).
6. Service the air filter; refer to [Servicing the Air Filter \(page 19\)](#).
7. Lubricate the pivot arms; refer to [Lubricating the Pivot Arms \(page 19\)](#).
8. Tighten all nuts, bolts, and screws.
9. Touch up all rusted or chipped paint surfaces with paint available from an Authorized Service Dealer.

Removing the Machine from Storage

1. Check and tighten all fasteners.
2. Remove the spark plug and spin the engine rapidly using the starter to blow excess oil from the cylinder.
3. Clean the spark plug or replace it if it is cracked, broken, or if the electrodes are worn.
4. Install the spark plug and torque it to 17 ft-lb (23 N-m).
5. Perform any needed maintenance procedures; refer to [Maintenance \(page 18\)](#).
6. Fill the fuel tank with fresh gasoline.
7. Check the engine oil level.
8. Connect the wire to the spark plug.

Troubleshooting

Problem	Possible Cause	Corrective Action
The engine does not start.	<ol style="list-style-type: none"> 1. The fuel tank is empty or the fuel system contains stale fuel. 2. The throttle lever is not in the Choke position. 3. The wire is not connected to the spark plug. 4. The spark plug is pitted, fouled, or the gap is incorrect. 	<ol style="list-style-type: none"> 1. Drain and/or fill the fuel tank with fresh gasoline. If the problem persists, contact an Authorized Service Dealer. 2. Move the throttle lever to the Choke position. 3. Connect the wire to the spark plug. 4. Check the spark plug and adjust the gap if necessary. Replace the spark plug if it is pitted, fouled, or cracked.
The engine starts hard or loses power.	<ol style="list-style-type: none"> 1. The fuel tank contains stale fuel. 2. The air filter element is dirty and is restricting the air flow. 3. The underside of the machine deck contains clippings and debris. 4. The spark plug is pitted, fouled, or the gap is incorrect. 5. The engine oil level is low or the oil is dirty. 	<ol style="list-style-type: none"> 1. Drain and fill the fuel tank with fresh gasoline. 2. Clean the air filter pre-cleaner and/or replace the paper air filter. 3. Clean the underside of the machine deck. 4. Check the spark plug and adjust the gap if necessary. Replace the spark plug if it is pitted, fouled, or cracked. 5. Check the engine oil. Change the oil if it is dirty or add oil if it is low.
The engine runs rough.	<ol style="list-style-type: none"> 1. The wire is not connected to the spark plug. 2. The spark plug is pitted or fouled, or the gap is incorrect. 3. The throttle lever is not in the Fast position. 4. The air filter element is dirty and is restricting the air flow. 	<ol style="list-style-type: none"> 1. Connect the wire to the spark plug. 2. Check the spark plug and adjust the gap if necessary. Replace the spark plug if it is pitted, fouled, or cracked. 3. Move the throttle lever to the Fast position. 4. Clean the air filter pre-cleaner and/or replace the paper air filter.
The machine or the engine vibrates excessively.	<ol style="list-style-type: none"> 1. The blade is bent or is out of balance. 2. The blade mounting nuts are loose. 3. The underside of the machine deck contains clippings and debris. 4. The engine mounting bolts are loose. 	<ol style="list-style-type: none"> 1. Balance the blade. If the blade is bent, replace it. 2. Tighten the blade mounting nuts. 3. Clean the underside of the machine deck. 4. Tighten the engine mounting bolts.
The cutting pattern is uneven.	<ol style="list-style-type: none"> 1. All 4 wheels are not at the same height. 2. The blade is dull. 3. You are mowing in the same pattern repeatedly. 4. The underside of the machine deck contains clippings and debris. 	<ol style="list-style-type: none"> 1. Place all 4 wheels at the same height. 2. Sharpen and balance the blade. 3. Change the mowing pattern. 4. Clean the underside of the machine deck.
The discharge chute plugs.	<ol style="list-style-type: none"> 1. The throttle lever is not in the Fast position. 2. The cutting height is too low. 3. You are mowing too fast. 4. The grass is wet. 5. The underside of the machine deck contains clippings and debris. 	<ol style="list-style-type: none"> 1. Move the throttle lever to the Fast position. 2. Raise the cutting height. 3. Slow down. 4. Allow the grass to dry before mowing. 5. Clean the underside of the machine deck.
The machine does not self-propel.	<ol style="list-style-type: none"> 1. The self-propel drive cable is out of adjustment or is damaged. 2. There is debris under the belt cover. 	<ol style="list-style-type: none"> 1. Adjust the self-propel drive cable. Replace the cable if necessary. 2. Clean the debris from under the belt cover.

Notes:

Notes:



The Toro Total Coverage Warranty

A Limited Warranty (see warranty periods below)

Landscape
Contractor
Equipment
(LCE)

Conditions and Products Covered

The Toro Company and its affiliate, Toro Warranty Company, pursuant to an agreement between them, jointly promise to the original purchaser to repair the Toro Products listed below if defective in materials or workmanship.

The following time periods apply from the date of purchase by the original owner:

Products	Warranty Period
21 in. Mowers • Engines ⁴	1 year Commercial Use Honda – 1 years Kawasaki – 3 years
21 in. Mowers • Engines ⁴	2 years Residential Use ¹ Honda – 2 years Kawasaki – 3 years
30 in. Mowers • Engines ⁴	2 years Commercial and Residential Use ¹ Kawasaki – 3 years
Mid-Size Walk-Behind Mowers • Engines ⁴	2 years Kawasaki – 3 years
Grand Stand® Mowers • Engines ⁴	5 years or 1,200 hours ² Kawasaki – 3 years Kohler EFI – 3 years Lifetime (original owner only) ³
Z Master® 2000 Series Mowers • Engines ⁴ • Frame	4 years or 500 hours ² Kawasaki – 3 years Lifetime (original owner only) ³
Z Master® 3000 Series Mowers • Engines ⁴ • Frame	5 years or 1,200 hours ² Kawasaki – 3 years Lifetime (original owner only) ³
Z Master® 5000 Series Mowers • Engines ⁴	5 years or 1,200 hours ² Kohler Command – 2 years Kohler EFI – 3 years Lifetime (original owner only) ³
Z Master® 6000 Series Mowers • Engines ⁴	5 years or 1,200 hours ² Kawasaki – 3 years Kohler Command – 2 years Kohler EFI – 3 years Lifetime (original owner only) ³
Z Master®7000 Series Mowers • Engines ⁴	4 years or 1,200 hours ² Kubota – 2 years Briggs & Stratton – 2 years Lifetime (original owner only) ³
All Mowers • Battery	90 days Parts and Labor 1 year Parts only
• Belts and Tires	90 days
• Attachments	1 year

¹Residential use means use of the product on the same lot as your home. Use at more than one location is considered commercial use and the commercial warranty would apply.

²Whichever occurs first.

³Lifetime Frame Warranty - If the main frame, consisting of the parts welded together to form the tractor structure that other components such as the engine are secured to, cracks or breaks in normal use, it will be repaired or replaced, at Toro's option, under warranty at no cost for parts and labor. Frame failure due to misuse or abuse and failure or repair required due to rust or corrosion are not covered.

⁴Some engines used on Toro Products are warranted by the engine manufacturer.

This warranty includes the cost of parts and labor, but you must pay transportation costs.

Instructions for Obtaining Warranty Service

If you think that your Toro Product contains a defect in materials or workmanship, follow this procedure:

1. Contact any Authorized Toro Service Dealer to arrange service at their dealership. To locate a dealer convenient to you, refer to the Yellow Pages of your telephone directory (look under "Lawn Mowers") or access our web site at www.Toro.com. You may also call the numbers listed in item #3 to use the 24-hour Toro Dealer locator system.
2. Bring the product and your proof of purchase (sales receipt) to the Service Dealer. The dealer will diagnose the problem and determine if it is covered under warranty.
3. If for any reason you are dissatisfied with the Service Dealer's analysis or with the assistance provided, contact us at:

RLC Customer Care Department
Toro Warranty Company
8111 Lyndale Avenue South
Bloomington, MN 55420-1196
888-865-5676 (U.S. Customers)
888-865-5691 (Canada customers)

Owner Responsibilities

You must maintain your Toro Product by following the maintenance procedures described in the *Operator's Manual*. Such routine maintenance, whether performed by a dealer or by you, is at your expense.

Items and Conditions Not Covered

There is no other express warranty except for special emission system and engine warranty coverage on some products. This express warranty does not cover the following:

- Cost of regular maintenance service or wear parts, such as filters, fuel, lubricants, tune-up parts, blade sharpening, brake and clutch adjustments.
- Any product or part which has been altered or misused and requires replacement or repair due to normal wear, accidents, or lack of proper maintenance.
- Repairs necessary due to improper fuel, contaminants in the fuel system, or failure to properly prepare the fuel system prior to any period of non-use over three months.
- Pickup and delivery charges.

General Conditions

All repairs covered by these warranties must be performed by an Authorized Toro Service Dealer using Toro approved replacement parts.

Neither The Toro Company nor Toro Warranty Company is liable for indirect, incidental or consequential damages in connection with the use of the Toro Products covered by this warranty, including any cost or expense of providing substitute equipment or service during reasonable periods of malfunction or non-use pending completion of repairs under this warranty.

All implied warranties of merchantability (that the product is fit for ordinary use) and fitness for use (that the product is fit for a particular purpose) are limited to the duration of the express warranty.

Some states do not allow exclusions of incidental or consequential damages, or limitations on how long an implied warranty lasts, so the above exclusions and limitations may not apply to you.

This warranty gives you specific legal rights, and you may also have other rights which vary from state to state.

Countries Other than the United States or Canada

Customers who have purchased Toro products outside the United States or Canada should contact their Toro Distributor (Dealer) to obtain guarantee policies for your country, province, or state. If for any reason you are dissatisfied with your Distributor's service or have difficulty obtaining guarantee information, contact the Toro importer. If all other remedies fail, you may contact us at Toro Warranty Company.

Australian Consumer Law: Australian customers will find details relating to the Australian Consumer Law either inside the box or at your local Toro Dealer. 374-0252 Rev E