



Count on it.

Parts Catalog

**FP-4000 Forward Plate
Compactor**

Model No. 68027—Serial No. 313000001 and Up



Ordering Replacement Parts

To order replacement parts, please supply the part number, the quantity, and the description of each part desired.

Understanding Reference Numbers

Each identified part in an illustration has a reference number. The reference number for a part also appears in the parts list, along with other information about the part.

This catalog uses two special reference number formats, one to indicate parts in a service assembly and another to indicate the quantity of a given part in an illustration.

Service Assembly Reference Numbers

Parts in service assemblies have reference numbers in the form a:b. The a represents the reference number of the entire service assembly and the b represents a sequential number unique to each part within the service assembly.

For example, a wheel assembly might be identified by reference number 6, the tire by 6:1, the valve by 6:2, and the wheel by 6:3. When you order the assembly identified by reference number 6, you receive all parts identified by reference numbers 6:1, 6:2, and 6:3. However, you may also order any part individually. Reference numbers of this type appear in illustration and in parts lists.

Reference Numbers Indicating Quantity

In an illustration, if a reference number indicates more than one part, the reference number has the form nX y. The n represents the quantity of the part, the X is the multiplication symbol, and the y represents the reference number.

For example, in an illustration, the reference number 2X 37 means that two of the parts identified by reference number 37 are indicated.

List of Abbreviations

AR: as required

ASM: assembly

BBC: blade brake control

BHTF: button head thread forming

CARR: carriage

CCW: counter clockwise

CW: clockwise

DEG: degrees

DPA: Dual Point Adjustment

ECM: electronic control module

EXT: external

FH: flat head

GA: gauge

HD: heavy-duty

HF: hex flange

HH: hex head

HHF: hex head flange

HHFTF: hex head flange thread forming

HJ: hex jam

HLH: hex lag head

HOC: height-of-cut

HSBH: hex socket button head

HSFH: hex socket flat head

HSH: hex socket head

HWH: hex washer head

HWHTF: hex washer head thread forming

HYD: hydraulic

LH: left hand

LP: Liquefied Petroleum Gas

LPG: Liquefied Petroleum Gas

NI: nylon insert

NPTF: national pipe thread fine

PFH: phillips flat head

PPH: phillips pan head

PPHTF: phillips pan head thread forming

PRH: phillips round head

PTH: phillips truss head

PTO: power-take-off

RH: right hand

ROPS: roll-over protection system

RRB: rear roller brush

SFH: slotted fillister head

SHH: slotted hex head

SHWH: slotted hex washer head

SPH: slotted pan head

SQH: square head

SRH: slotted round head

STD: standard

TAP: self tapping

TTH: torx truss head

Contents

Handle and Base Assembly 4
Base Assembly No. 125-6237 5
Engine Assembly 6
Roll Cage and Water Assembly 7

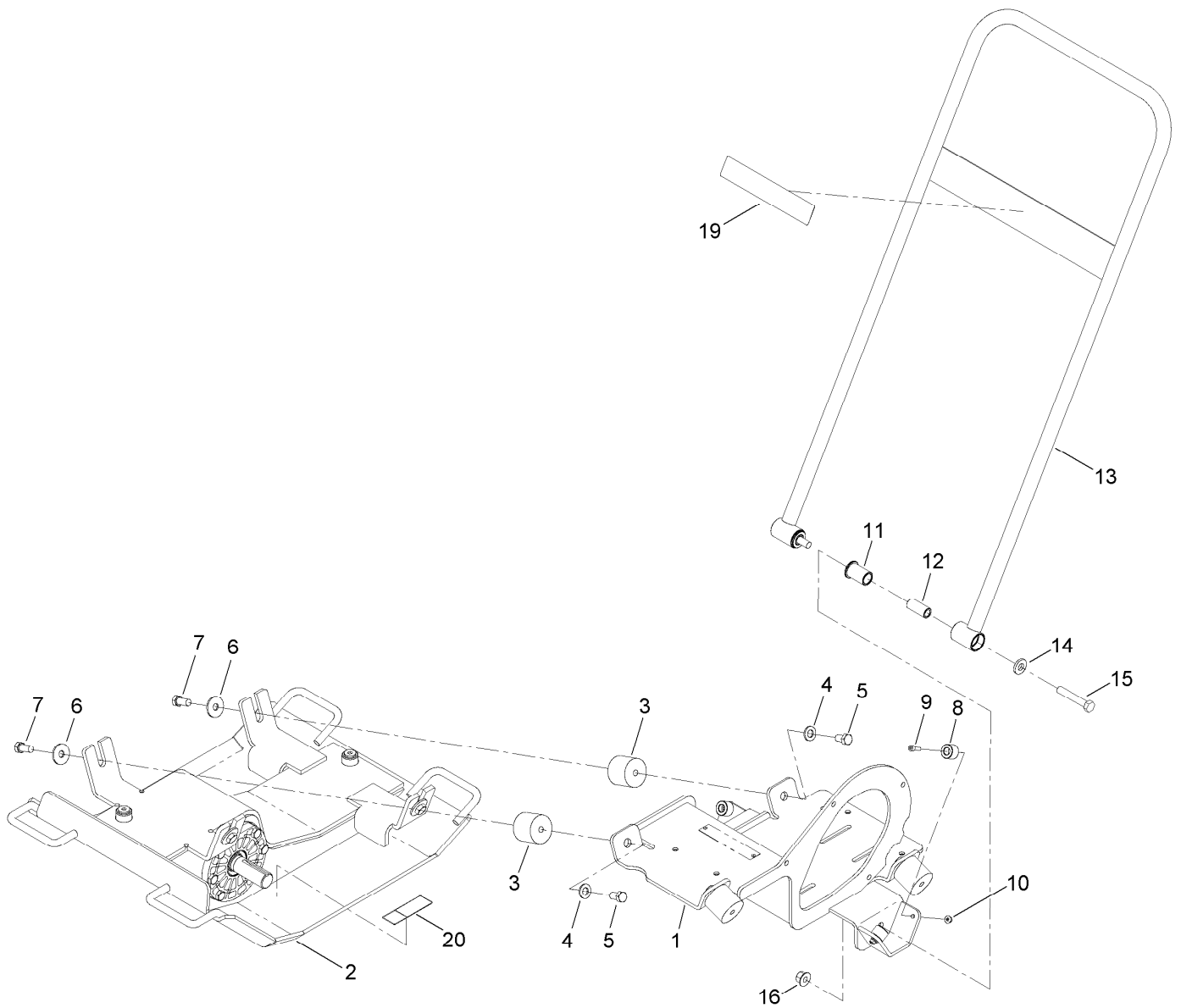

Handle and Base Assembly

Ref.	Part Number	Qty.	Description	Ref.	Part Number	Qty.	Description
1	125-6249-03	1	Deck-Engine	10	33003-00	4	Nut-HF
2	125-6237	1	Base ASM	11	ST50263	2	Bushing-Handle, Main Plate
3	ST65004	4	Mount-Shock	12	ST50264	2	Spacer-Handle, Pivot
4	33096-00	4	Washer-Flat	13	ST50260-03	1	Handle-Main
5	33116-020	4	Screw-HH	14	ST80891	2	Washer-Flat
6	ST80835	4	Washer-Flat	15	33116-070	2	Screw-HH
7	33116-025	4	Screw-HH	16	115-1115	2	Nut-HHF, Lock
8	ST50265	4	Spacer-Stop, Handle	19	125-4930	1	Decal
9	ST81213	4	Screw-HSH	20	117-4979	1	Decal-Warning, Shields (Ce)

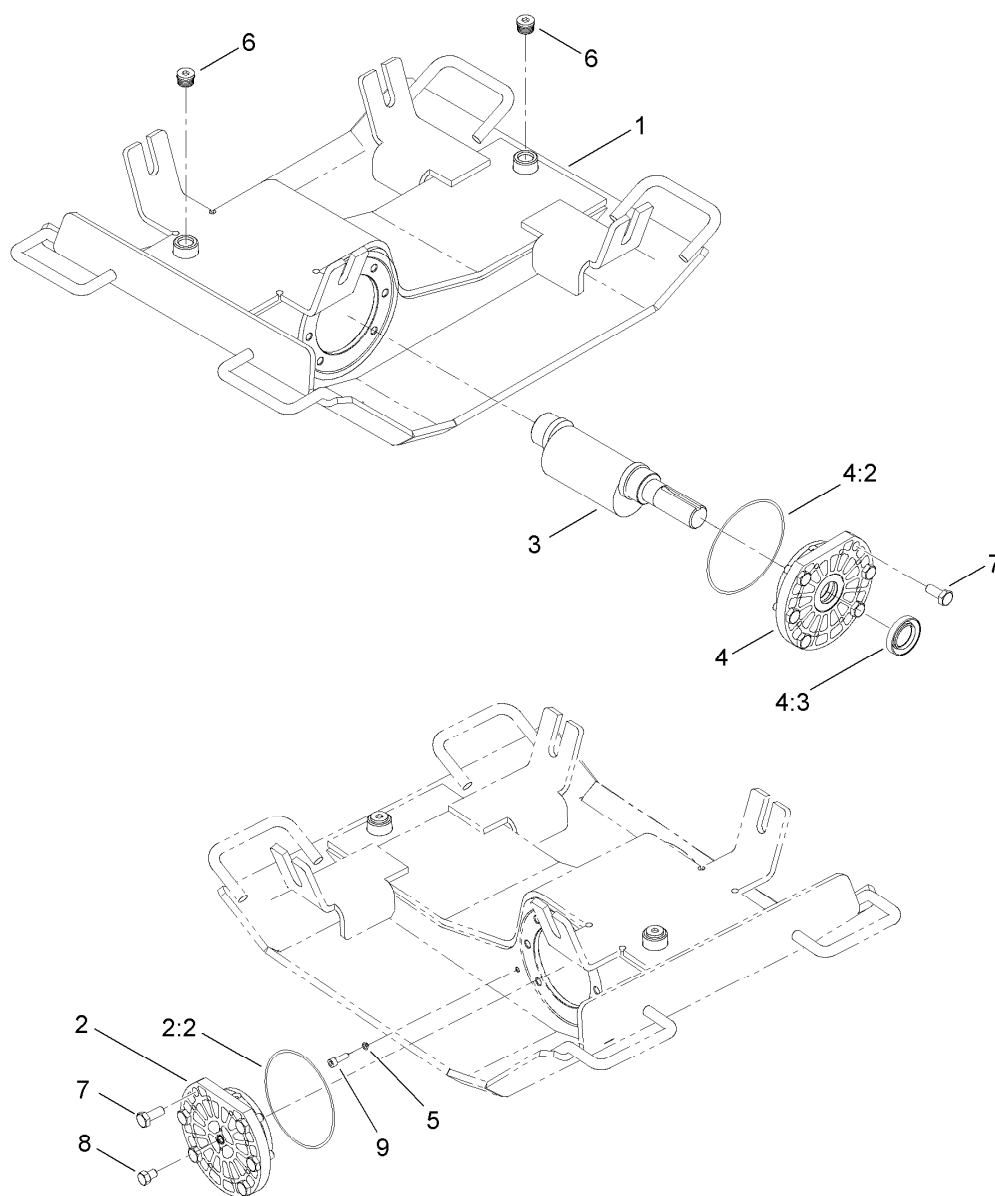

Base Assembly No. 125-6237

Ref.	Part Number	Qty.	Description
1	ST50205-03	1	Base
2	ST22063	1	Plate Cap Bearing ASM (Blind End)
2:2	ST32033	1	O-Ring
3	ST21543	1	Shaft-Eccentric
4	ST22062	1	Plate Cap Bearing ASM (Sheave End)
4:2	ST32033	1	O-Ring
4:3	ST32047	2	Seal-Shaft
5	ST81210	1	Washer-Sealing, Nyltite
6	ST47647	2	Fitting-HYD
7	43-0090	12	Screw-HH
8	ST80185	1	Screw-HH
9	ST81213	1	Screw-HSH

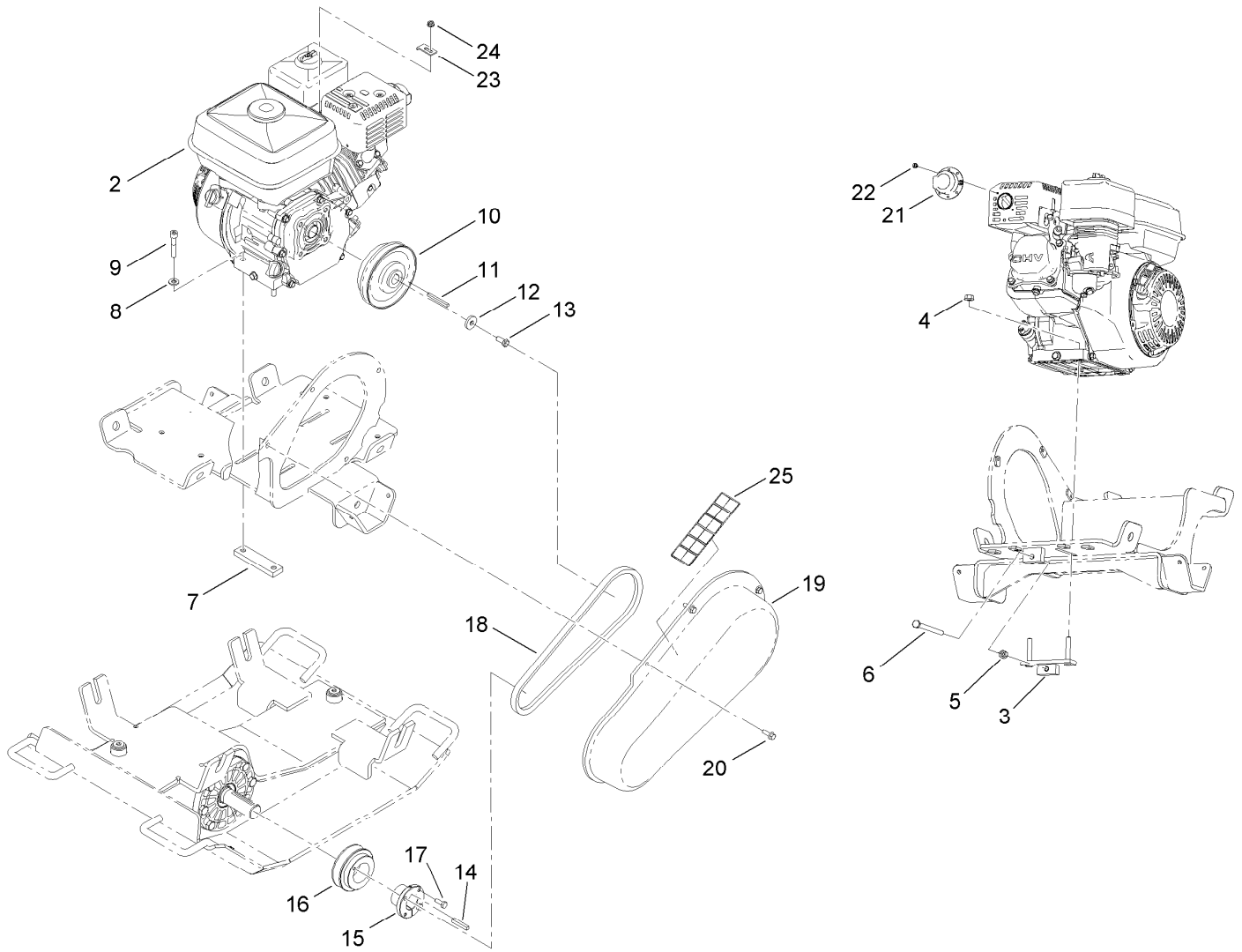

Engine Assembly

Ref.	Part Number	Qty.	Description
2	125-4813	1	Engine-Honda, Gx160
3	ST50257	1	Bracket-Adjuster, Engine
4	33004-00	2	Nut-HF
5	33014-00	1	Nut-Hex
6	ST81191	1	Screw
7	ST50506	1	Plate-Nut, Engine
8	33094-00	2	Washer-Plain
9	ST80966	2	Screw-HSH
10	ST32347	1	Clutch, S-Plate
11	ST80611	1	Key-Square
12	ST39233	1	Washer
13	3235-6	1	Screw-HH

Ref.	Part Number	Qty.	Description
14	ST80061	1	Key-Square
15	ST32798	1	Bushing
16	ST32797	1	Sheave
17	321-4	2	Screw-HH
18	ST50500	1	Belt-V
19	125-4805	1	Guard-Belt
20	33103-020	4	Screw-HHF
21	ST30166	1	Deflector-Exhaust
22	ST80766	2	Screw-HWH
23	ST42790	1	Clip-Throttle
24	32128-17	1	Nut-Lock, Flange
25	125-4943	1	Decal-Warning, Plate

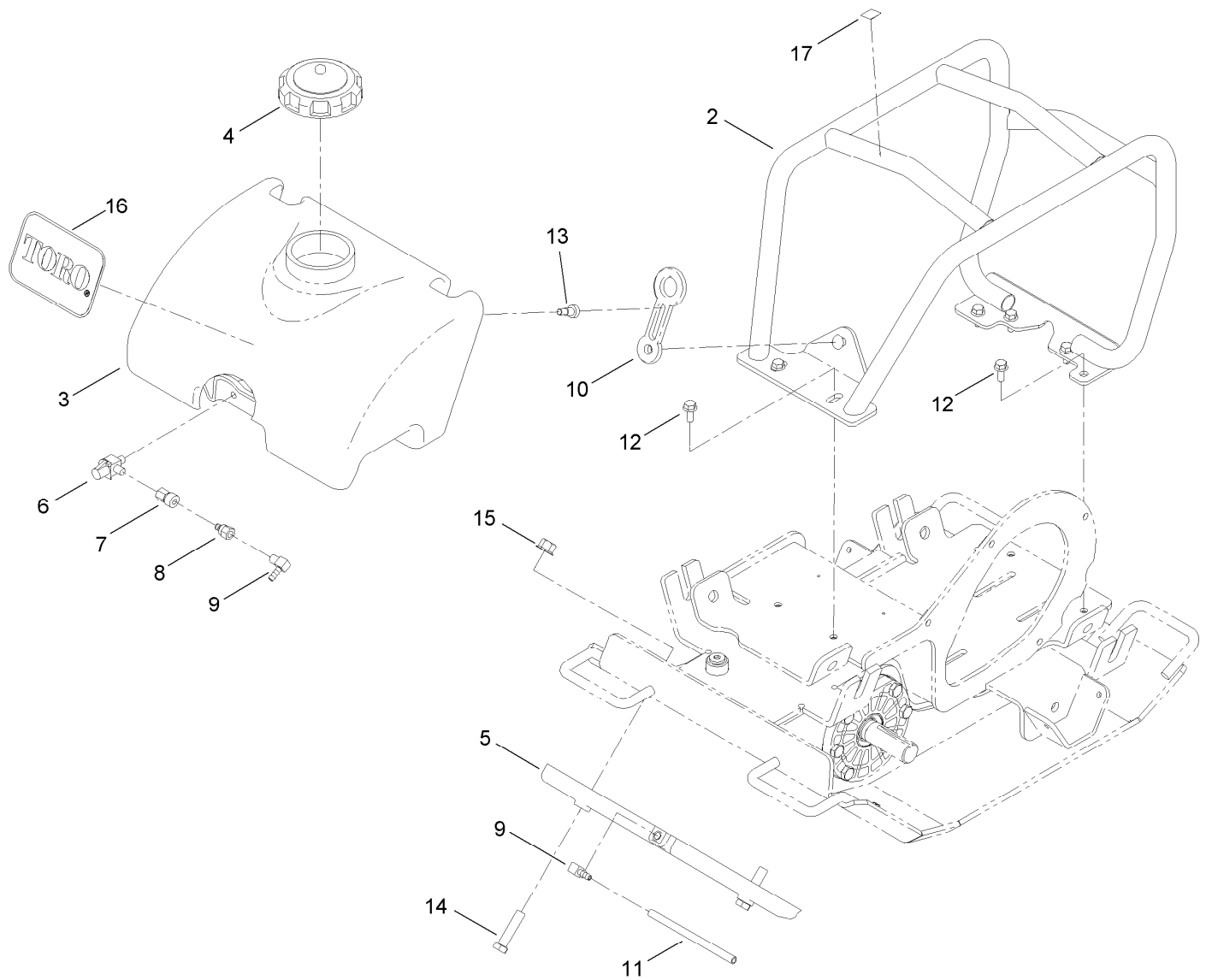

Roll Cage and Water Assembly

Ref.	Part Number	Qty.	Description
2	ST50215-03	1	Cage-Roll
3	125-4810	1	Tank-Water
4	ST47241	1	Cap-Plastic
5	125-8217	1	Sprinkler
6	ST50497	1	Valve-Ball
7	ST50498	1	Fitting-Quick, Female
8	ST50499	1	Fitting-Quick, Female, Nipple
9	ST34486	2	Fitting-HYD, 90 DEG

Ref.	Part Number	Qty.	Description
10	ST47182	1	Latch-Rubber
11	ST47250	1	Hose-Water
12	33104-020	6	Screw-HHF
13	ST81130	1	Screw-HSBH
14	33116-050	2	Screw-HH
15	115-1115	2	Nut-HHF, Lock
16	68-3640	1	Decal
17	93-9084	1	Decal-Point, Lift



Count on it.