



**Count on it.**

**Parts Catalog**

**21in Heavy-Duty**

**Recycler<sup>®</sup>/Rear Bagger Lawn Mower**

**Model No. 22196—Serial No. 312000001 and Up**



# Ordering Replacement Parts

To order replacement parts, please supply the part number, the quantity, and the description of each part desired.

## Understanding Reference Numbers

Each identified part in an illustration has a reference number. The reference number for a part also appears in the parts list, along with other information about the part.

This catalog uses two special reference number formats, one to indicate parts in a service assembly and another to indicate the quantity of a given part in an illustration.

## Service Assembly Reference Numbers

Parts in service assemblies have reference numbers in the form a:b. The a represents the reference number of the entire service assembly and the b represents a sequential number unique to each part within the service assembly.

For example, a wheel assembly might be identified by reference number 6, the tire by 6:1, the valve by 6:2, and the wheel by 6:3. When you order the assembly identified by reference number 6, you receive all parts identified by reference numbers 6:1, 6:2, and 6:3. However, you may also order any part individually. Reference numbers of this type appear in illustration and in parts lists.

## Reference Numbers Indicating Quantity

In an illustration, if a reference number indicates more than one part, the reference number has the form nX y. The n represents the quantity of the part, the X is the multiplication symbol, and the y represents the reference number.

For example, in an illustration, the reference number 2X 37 means that two of the parts identified by reference number 37 are indicated.

# List of Abbreviations

**AR:** as required

**ASM:** assembly

**BBC:** blade brake control

**BHTF:** button head thread forming

**CARR:** carriage

**CCW:** counter clockwise

**CW:** clockwise

**DEG:** degrees

**DPA:** Dual Point Adjustment

**ECM:** electronic control module

**EXT:** external

**FH:** flat head

**GA:** gauge

**HD:** heavy-duty

**HF:** hex flange

**HH:** hex head

**HHF:** hex head flange

**HHFTF:** hex head flange thread forming

**HJ:** hex jam

**HLH:** hex lag head

**HOC:** height-of-cut

**HSBH:** hex socket button head

**HSFH:** hex socket flat head

**HSH:** hex socket head

**HWH:** hex washer head

**HWHTF:** hex washer head thread forming

**HYD:** hydraulic

**LH:** left hand

**LPG:** Liquid Propane Gas

**NI:** nylon insert

**NPTF:** national pipe thread fine

**PFH:** phillips flat head

**PPH:** phillips pan head

**PPHTF:** phillips pan head thread forming

**PRH:** phillips round head

**PTH:** phillips truss head

**PTO:** power-take-off

**RH:** right hand

**ROPS:** roll-over protection system

**RRB:** rear roller brush

**SFH:** slotted fillister head

**SHH:** slotted hex head

**SHWH:** slotted hex washer head

**SPH:** slotted pan head

**SQH:** square head

**SRH:** slotted round head

**STD:** standard

**TAP:** self tapping

**TTH:** torx truss head

# Contents

Housing, Chute and Wheel Assembly.....	4
Housing Assembly No. 98-7146 .....	6
Front Wheel and Tire Assembly No. 121-1380 .....	7
Blade Brake Clutch Assembly .....	8
Engine and Fuel Tank Assembly .....	10
Handle Assembly .....	11
Control Panel Assembly .....	12
Gearbox and Axle Assembly .....	13
Rear Wheel and Tire Assembly No. 121-1379 .....	14
Gear Case Assembly No. 74-1860 .....	15
Grass Bag Assembly No. 121-1391 .....	16
Attachments and Accessories .....	17

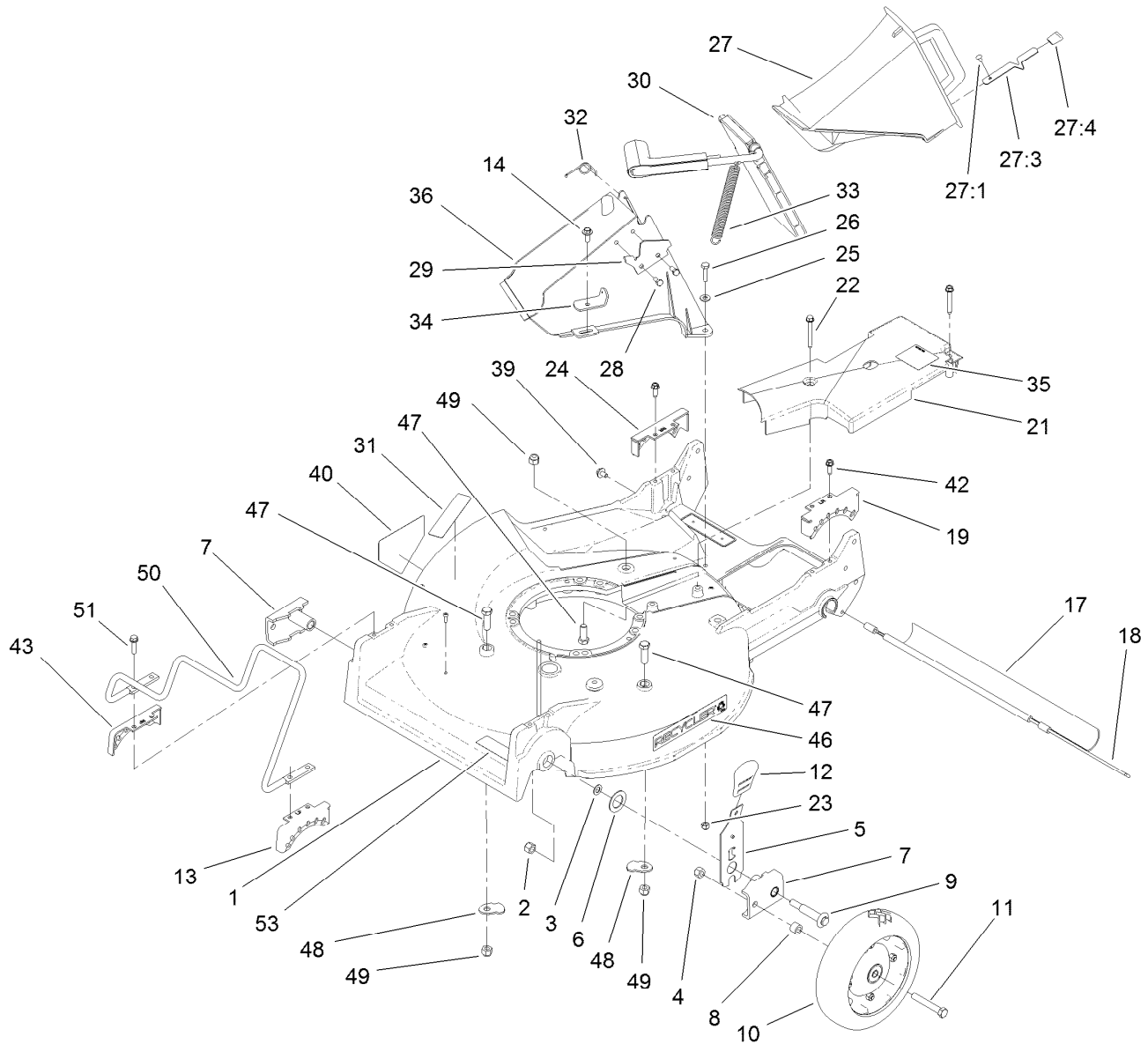

## Housing, Chute and Wheel Assembly

Ref.	Part Number	Qty.	Description	Ref.	Part Number	Qty.	Description
1	98-7146	1	Housing	25	3256-22	2	Washer-Flat
2	3296-6	2	Nut-Lock	26	321-8	2	Screw-HH
3	40-1940	2	Washer	27	77-0500	1	Discharge Plug ASM
4	32152-2	2	Nut-Lock, Cone	27:1	3295-35	1	Rivet-Head, Flat
5	119-2323	2	Front Spring Arm ASM	27:3	76-4640	1	Latch-Plug, Discharge
6	257-3	2	Washer-Thrust	27:4	76-4650	1	Grip-Latch
7	61-8300	2	Arm-Pivot, Front	28	46-8090	2	Screw-Plastite
8	52-2480	2	Spacer-Wheel	29	93-3154	1	Latch-Plate
9	114-3468	2	Screw-Shoulder	30	93-7351	1	Discharge Door ASM
10	121-1380	2	Wheel And Tire ASM	31	117-2718	1	Decal-Arrester, Spark
11	323-12	2	Screw-HH	32	80-3770	1	Retainer-Door
12	110-0549	2	Knob-HOC	33	76-4660	1	Spring-Door
13	49-8760	1	Quadrant-Front, LH	34	71-9350	1	Bracket-Spring
14	46-6811	1	Screw-HWH	35	119-7894	1	Decal-Grease
17	112-9989	1	Shield-Trailing	36	82-9152	1	Tunnel-Discharge
18	33-3208	1	Rod-Shield	39	46-6810	1	Screw And Washer ASM
19	49-8740	1	Quadrant-Rear, LH	40	94-8072	1	Decal-Danger
21	74-1770	1	Cover-Belt	42	49-2040	4	Screw-HWHTF
22	117-5248	2	Screw-HWHTF	43	49-8770	1	Quadrant-Front, RH
23	3296-42	2	Nut-Lock, NI	46	106-0689	1	Decal
24	49-8750	1	Quadrant-Rear, RH	47	323-6	3	Screw-HH

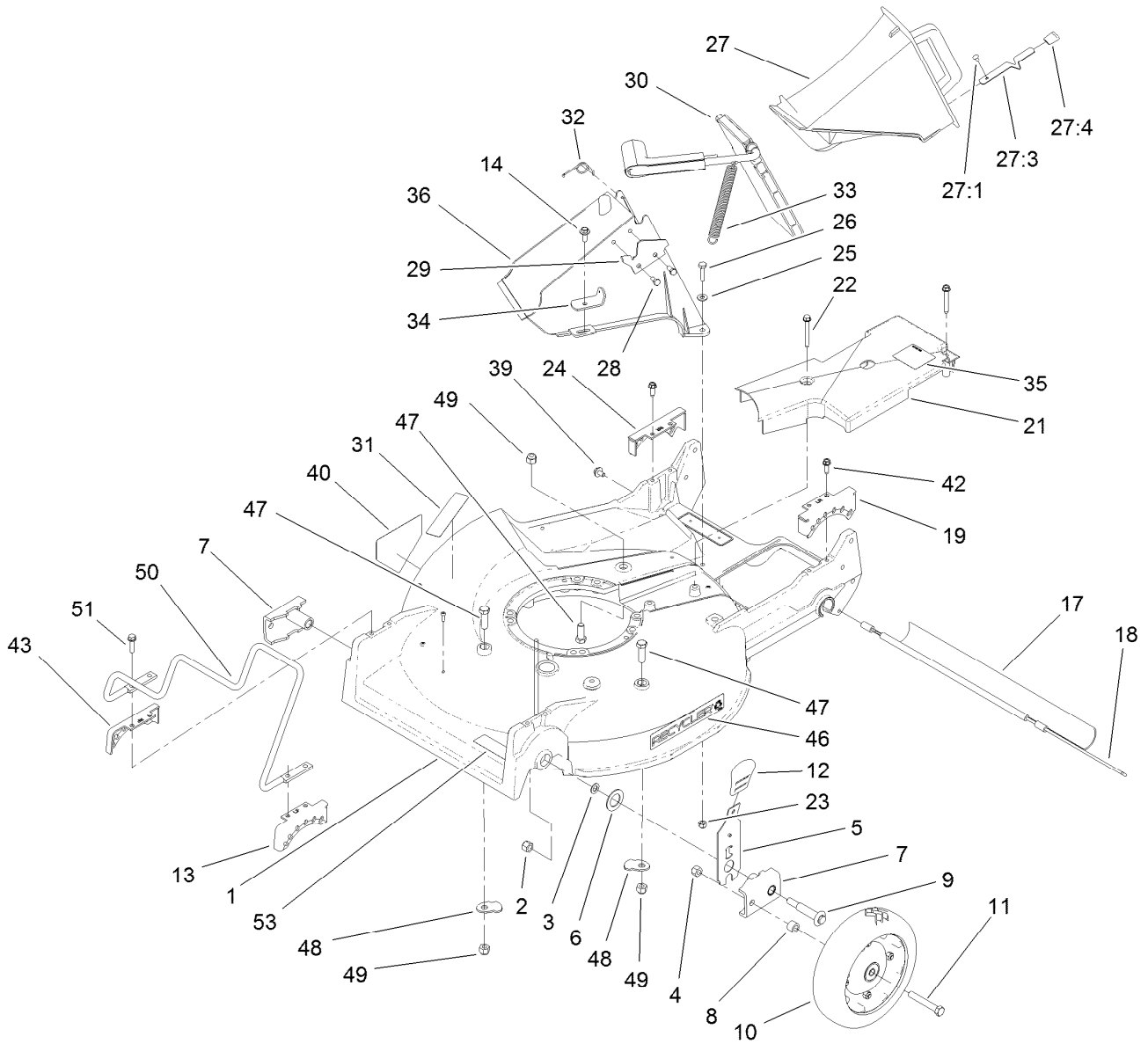

## Housing, Chute and Wheel Assembly (continued)

<i>Ref.</i>	<i>Part Number</i>	<i>Qty.</i>	<i>Description</i>	<i>Ref.</i>	<i>Part Number</i>	<i>Qty.</i>	<i>Description</i>
48	84-8930	2	Shield-Retainer	51	32144-86	4	Screw-HWHTF
49	3296-39	3	Nut-Lock, NI	53	68-7410	1	Decal-Blade
50	109-7638	1	Guard-Engine				

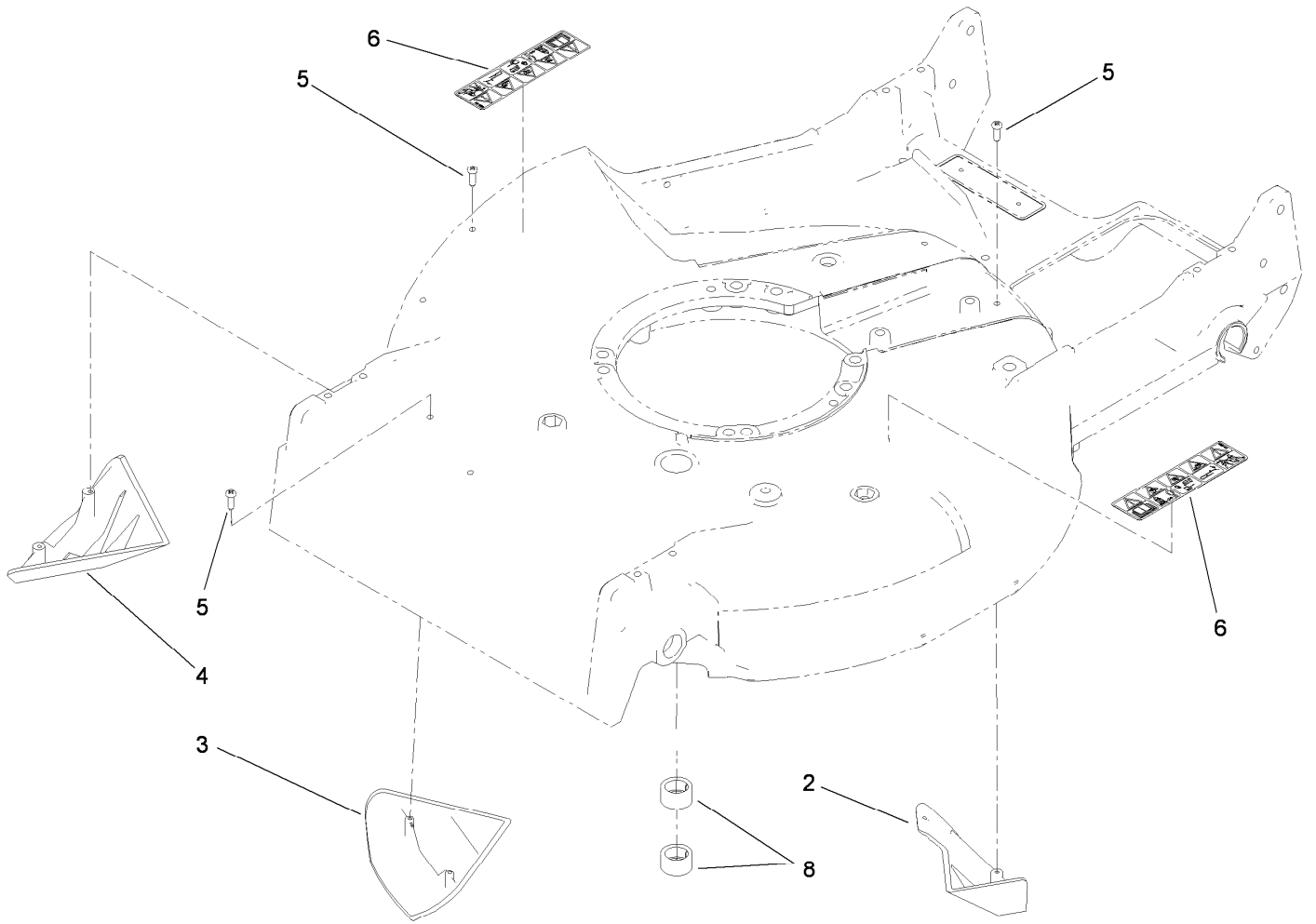

## Housing Assembly No. 98-7146

Ref.	Part Number	Qty.	Description
2	92-1750	1	Kicker-Rear
3	92-1720	1	Kicker-Front
4	92-1730	1	Kicker-RH
5	32144-111	6	Screw-PPH
6	110-4978	2	Decal-Danger
8	68-9780	2	Bearing

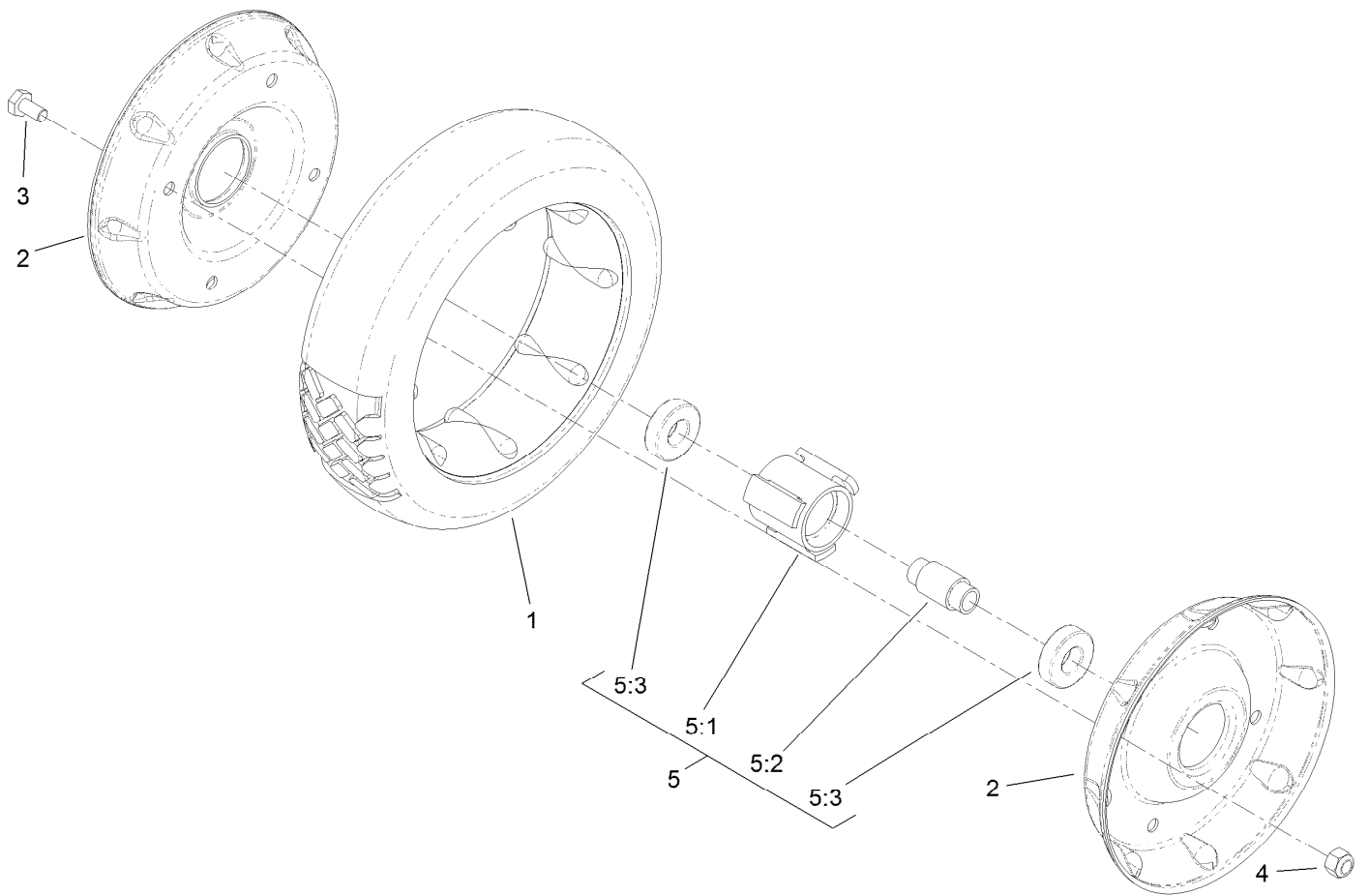

## Front Wheel and Tire Assembly No. 121-1380

<i>Ref.</i>	<i>Part Number</i>	<i>Qty.</i>	<i>Description</i>
1	53-7740	1	Tire
2	121-1365-06	2	Rim-Half, Wheel
3	321-2	4	Screw-HH
4	3296-42	4	Nut-Lock, NI
5	121-1377	1	Hub And Bearing ASM
5:1	52-2410	1	Hub-Bearing
5:2	52-2440	1	Spacer-Bearing
5:3	109-8020	2	Bearing-Ball

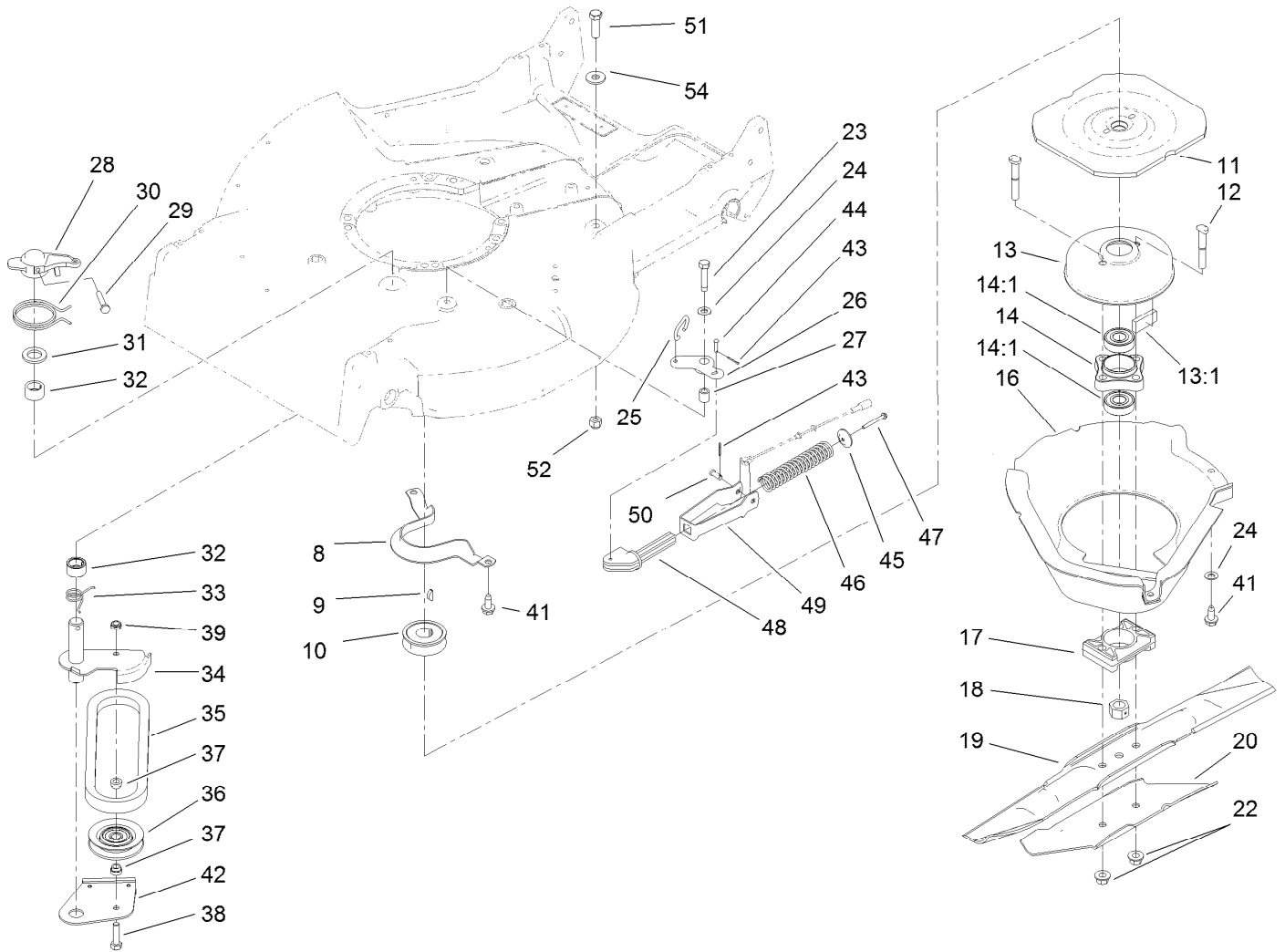

## Blade Brake Clutch Assembly

Ref.	Part Number	Qty.	Description	Ref.	Part Number	Qty.	Description
8	66-0570-03	1	Bracket-Guide, Belt	29	32104-96	1	Screw-HH
9	3257-17	1	Key-Woodruff	30	49-7970	1	Spring-Torsion
10	56-6180	1	Pulley-Driver	31	70-1160	1	Washer
11	56-6160-03	1	Flywheel-BBC	32	68-9780	2	Bearing
12	42-3190	2	Bolt-Blade	33	85-6880	1	Spring-Torsion
13	94-9431	1	Brake Drum ASM	34	84-9130	1	Arm-Idler
13:1	52-3480	2	Dampener-Vibration	35	42-0884	1	V-Belt
14	42-6890	1	Hub ASM	36	117-5299	1	Pulley-Idler
14:1	100-1048	2	Bearing-Ball	37	46-5631	2	Spacer-Pulley, Idler
16	46-5693	1	Shield	38	322-6	1	Screw-HH
17	107-4275	1	Spacer-Blade	39	3296-47	1	Nut-Lock, NI
18	603164	1	Nut-Blade	41	32144-70	3	Screw-HWHTF
19	91-2256-03	1	Blade-21 Inch	42	121-1351	1	Brake Plate ASM
20	91-2255-03	1	Stiffener-Blade	43	3272-1	2	Pin-Cotter
22	54-9190	2	Nut-Lock	44	84-9050	1	Pin-Spring
23	32104-107	1	Screw-HH	45	65-5280	1	Retainer-Spring
24	3256-23	2	Washer-Flat	46	84-9100	1	Screw
25	49-2810	1	Link-Control	47	46-7040	1	Screw-HWHTF
26	49-7960	1	Bellcrank	48	106-0842	1	Guide-Spring
27	49-7950	1	Sleeve-Bellcrank	49	107-4087-03	1	Bracket-Spring
28	49-2820	1	Lever	50	84-9040	1	Pin-Cable

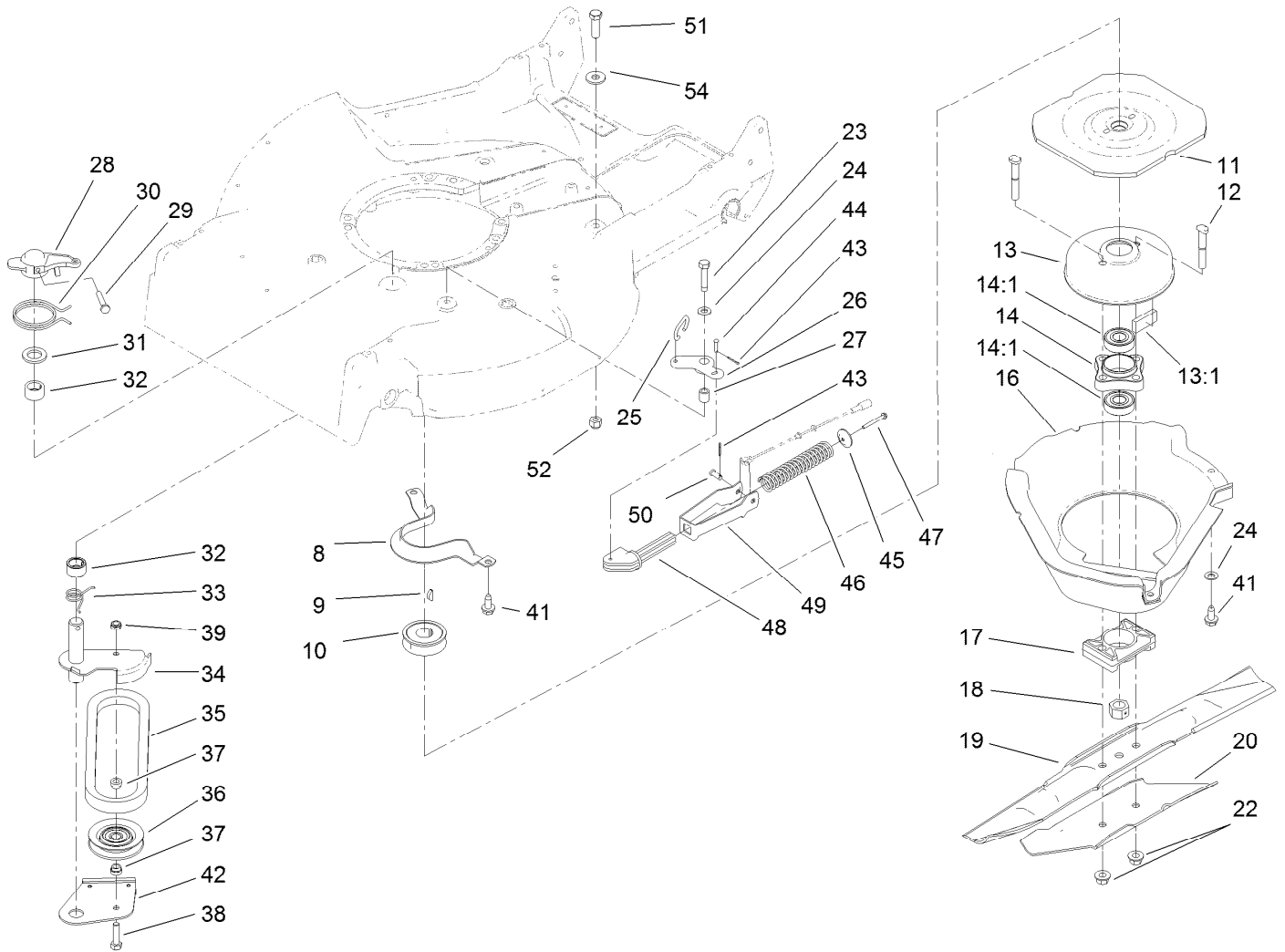

## Blade Brake Clutch Assembly (continued)

Ref.	Part Number	Qty.	Description
51	323-7	1	Screw-HH

Ref.	Part Number	Qty.	Description
52	3296-39	1	Nut-Lock, NI
54	80-6990	1	Washer-Hardened

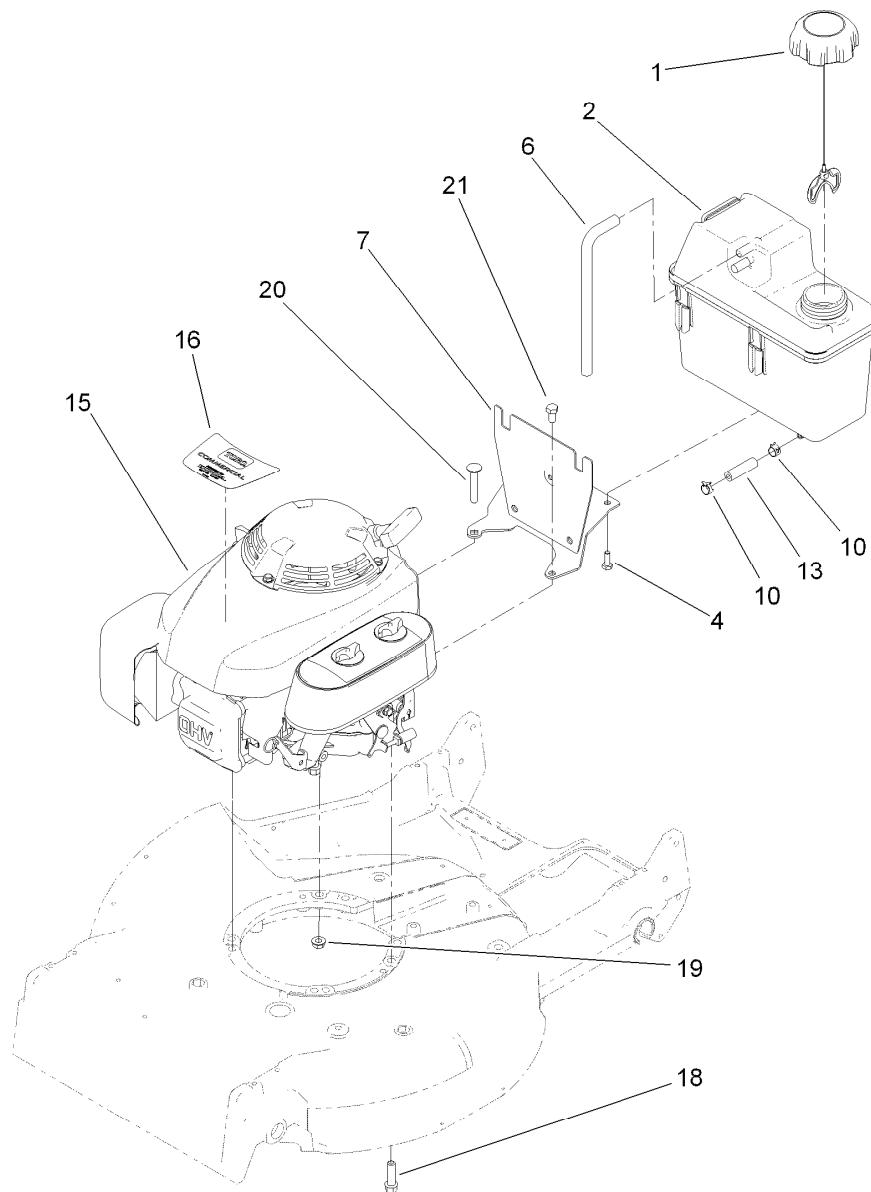

## Engine and Fuel Tank Assembly

Ref.	Part Number	Qty.	Description
1	109-6776	1	Cap-Ratchet, Tethered
2	114-0280	1	Tank-Fuel
4	46-8091	2	Screw-HWH
6	115-0962	1	Hose-Vent, Canister
7	119-7837-03	1	Tank Mount ASM
10	2412-98	2	Clamp-Hose
13	119-7856	1	Hose-Fuel
15		1	Engine-Honda, BBC Gxv160 ●
16	112-9974	1	Decal-Engine, Honda
18	103-2678	3	Screw-Shoulder
19	3230-6	1	Screw-CARR
20	32128-25	1	Nut-HF
21	3210-2	1	Screw-HH

● Not serviced separately

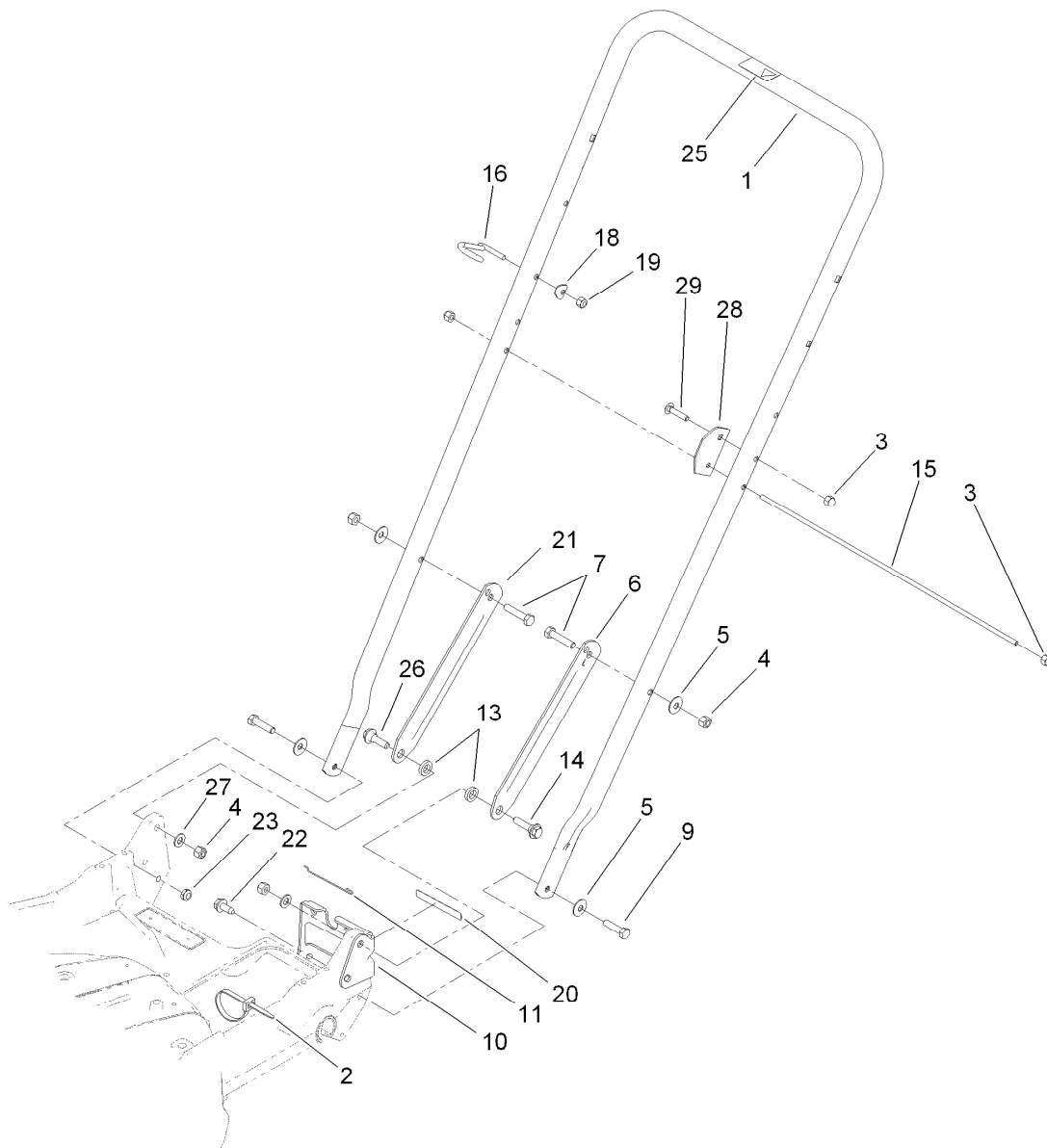

## Handle Assembly

<i>Ref.</i>	<i>Part Number</i>	<i>Qty.</i>	<i>Description</i>	<i>Ref.</i>	<i>Part Number</i>	<i>Qty.</i>	<i>Description</i>
1	98-2385-03	1	Handle	15	48-2810	1	Rod-Support, Bag
2	3290-378	1	Tie-Cable	16	114-2775	1	Guide-Rope
3	32111-7	3	Nut-Cap	18	3-7501	1	Washer
4	3296-29	4	Nut-Lock, NI	19	3296-42	1	Nut-Lock, NI
5	3290-456	4	Washer-Belleville	20	74-1970	1	Decal-Position, Gear
6	100-3298-03	1	Latch-Handle, LH	21	100-3297-03	1	Latch-Handle, RH
7	322-7	2	Screw-HH	22	32144-70	1	Screw-HWHTF
9	322-6	2	Screw-HH	23	3296-47	2	Nut-Lock, NI
10	74-1741	1	Bracket-Adjustment, Traction	25	98-4387	1	Decal-Protection, Ear
11	46-7030	1	Retainer-Cable	26	27-7211	1	Screw-Shoulder
13	3-3287	2	Spacer	27	3256-23	2	Washer-Flat
14	27-7210	1	Screw-Shoulder	28	104-1326	1	Plate-Aligning, Bag
				29	3229-3	1	Screw-CARR

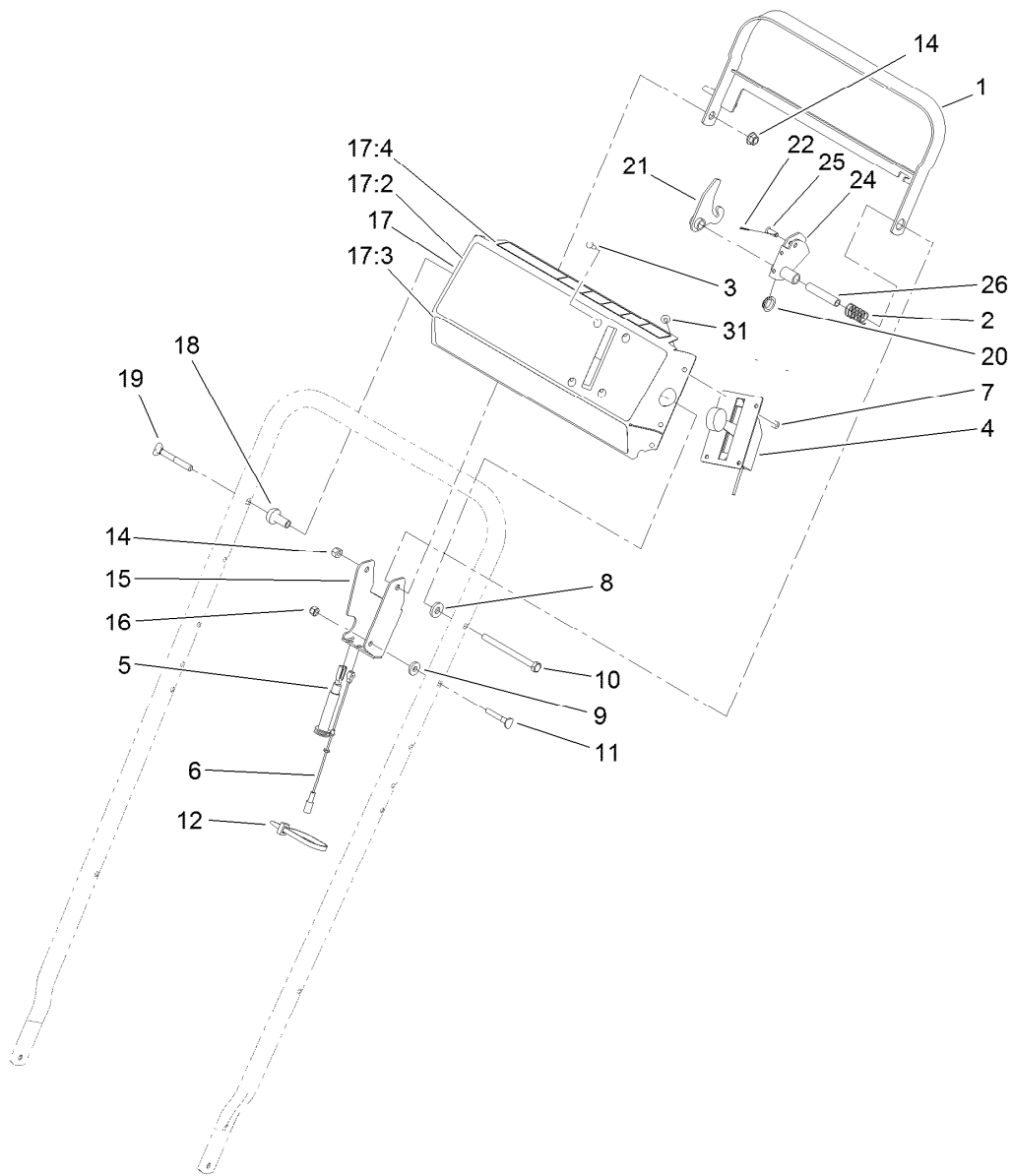

## Control Panel Assembly

<i>Ref.</i>	<i>Part Number</i>	<i>Qty.</i>	<i>Description</i>	<i>Ref.</i>	<i>Part Number</i>	<i>Qty.</i>	<i>Description</i>
1	84-8940-03	1	Bar-Control	16	3296-42	1	Nut-Lock, NI
2	85-6750	1	Spring-Control	17	14-7709	1	Panel ASM
3	3250-12	4	Screw-PPH	17:2	107-4098	1	Decal-Panel
4	117-3543	1	Control-Throttle	17:3	106-0771	1	Decal-Panel
5	84-9120	1	Cable-Traction	17:4	112-8736	1	Decal-Danger Panel
6	84-9110	1	Cable-Clutch	18	49-1631	1	Spacer-Support
7	3296-2	4	Nut-Lock, NI	19	17-9427	1	Screw
8	71-9310	1	Spacer	20	86-9320	1	Bushing-Flange
9	71-9320	1	Spacer	21	84-9000	1	Lever-Traction
10	322-19	1	Screw-HH	22	3272-1	1	Pin-Cotter
11	46-6430	1	Screw-Handle	24	84-8990	1	Lever-BBC
12	3290-378	1	Tie-Cable	25	84-9040	1	Pin-Cable
14	104-8300	2	Nut-Flange, NI	26	84-9030	1	Spacer-Bracket, Control
15	92-1778-03	1	Bracket-Control	31	32104-76	6	Screw-Thd Cutting,HWH

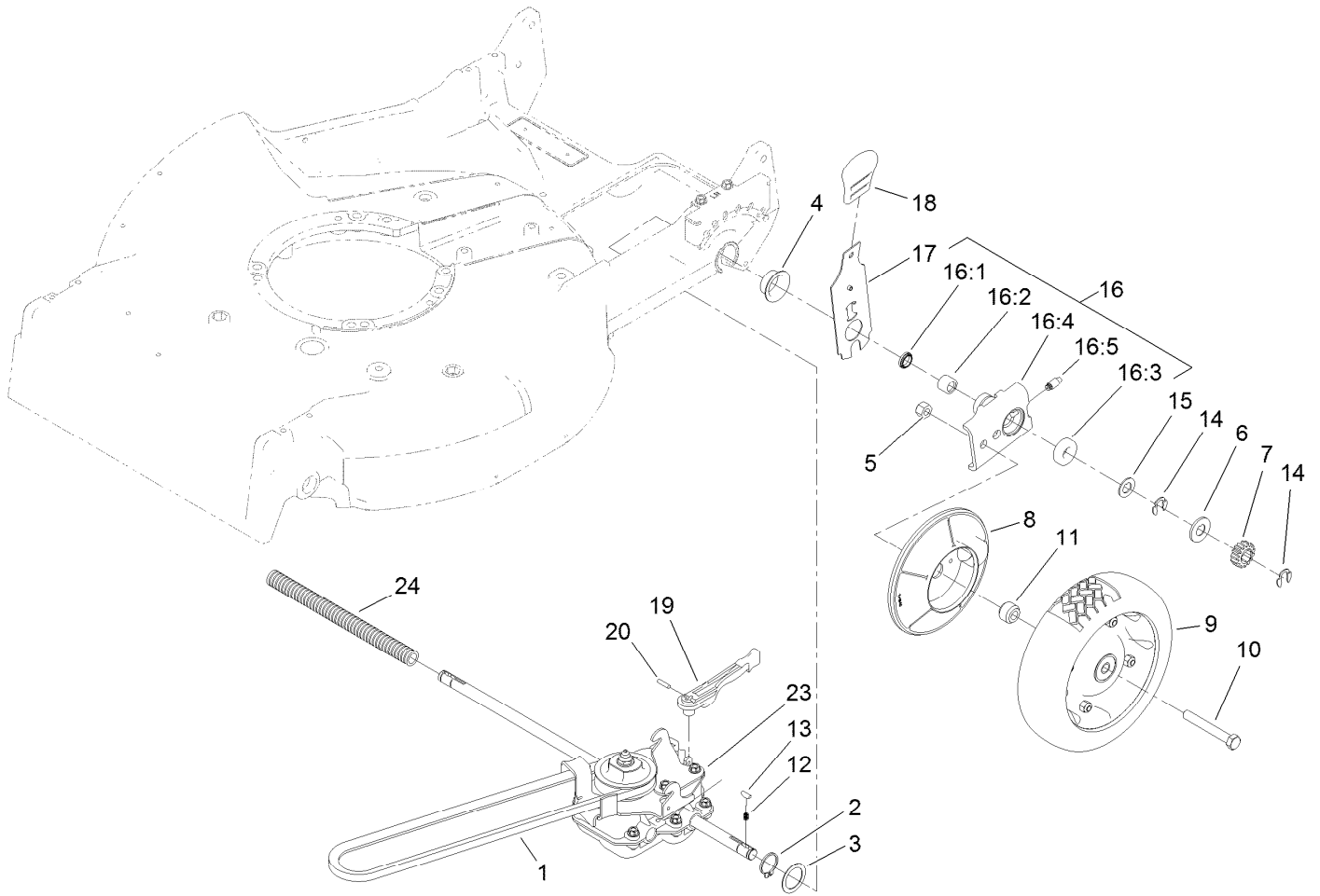

## Gearbox and Axle Assembly

<i>Ref.</i>	<i>Part Number</i>	<i>Qty.</i>	<i>Description</i>	<i>Ref.</i>	<i>Part Number</i>	<i>Qty.</i>	<i>Description</i>
1	36-8070	1	V-Belt	15	49-7700	2	Washer-Thrust, Outer
2	32151-36	2	Ring-Retaining	16	74-1851	2	Pivot Arm ASM
3	74-1810	2	Washer	16:1	47-6730	1	Seal-Oil
4	48-2170	2	Cap-End	16:2	117-3500	1	Bearing-Caged Needle Roller
5	32152-2	2	Nut-Lock, Cone	16:3	52-2450	1	Bearing-Wheel
6	62-3830	2	Washer-Thrust, Outer	16:4		1	Arm-Pivot, Rear ●
7	39-9160	2	Gear-Pinion	16:5	92-6316	1	Zerk
8	74-1640	2	Cover-Wheel	17	119-2324	2	Rear Spring Arm ASM
9	121-1379	2	Wheel And Tire ASM	18	110-0549	2	Knob-HOC
10	323-13	2	Screw-HH	19	74-1960	1	Lever-Shift
11	74-1650	2	Spacer-Cover, Wheel	20	32121-99	1	Pin-Coil
12	39-9650	2	Spring-Compression	23	74-1860	1	Gear Case ASM
13	612066	2	Key	24	121-1357	1	Cover-Shaft, Drive
14	32151-68	4	Ring-Retaining				

● Not serviced separately

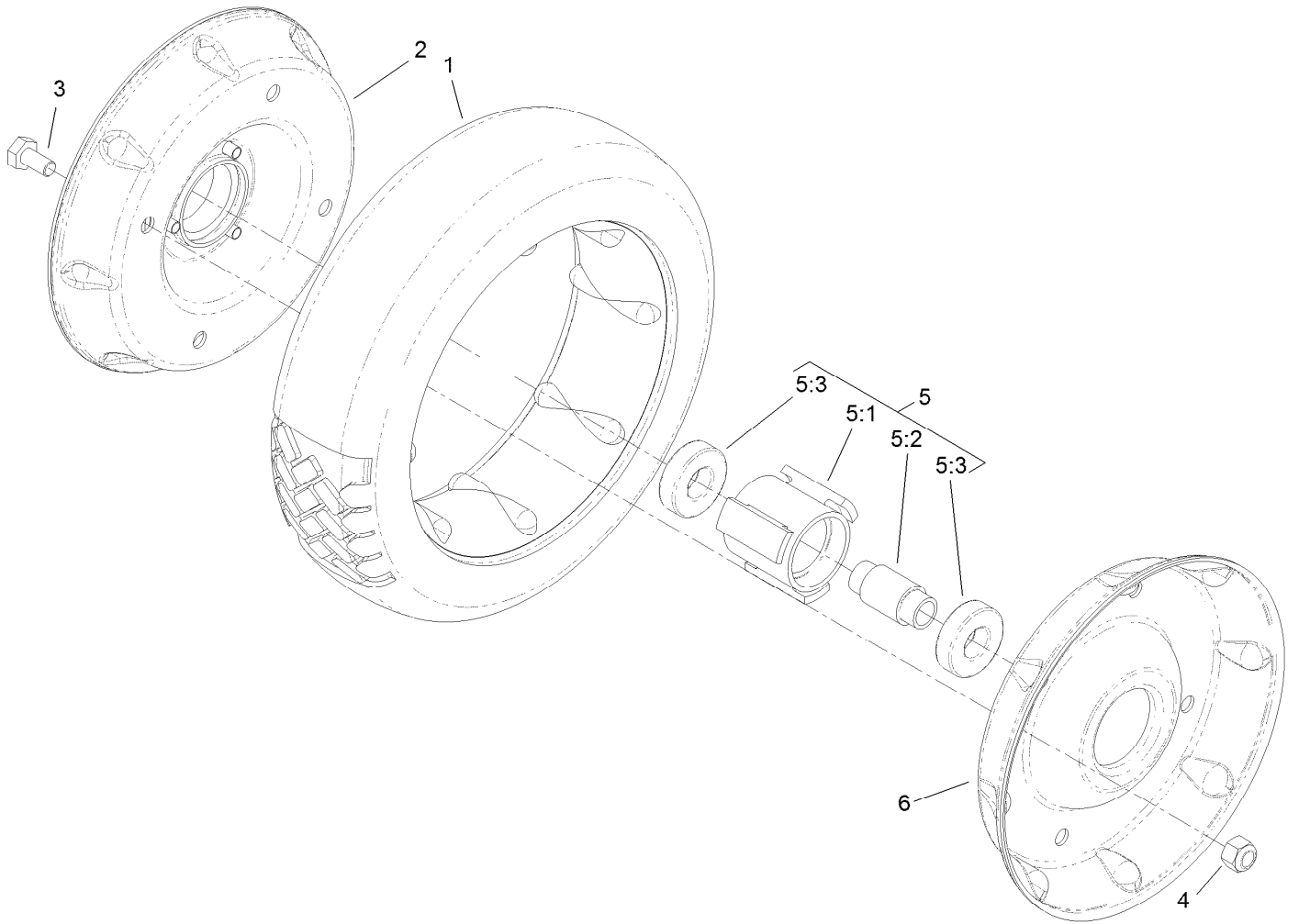

## Rear Wheel and Tire Assembly No. 121-1379

<i>Ref.</i>	<i>Part Number</i>	<i>Qty.</i>	<i>Description</i>
1	53-7740	1	Tire
2	121-1378-06	1	Wheel Half And Gear ASM
3	321-2	4	Screw-HH
4	3296-42	4	Nut-Lock, NI
5	121-1377	1	Hub And Bearing ASM
5:1	52-2410	1	Hub-Bearing
5:2	52-2440	1	Spacer-Bearing
5:3	109-8020	2	Bearing-Ball
6	121-1365-06	1	Rim-Half, Wheel

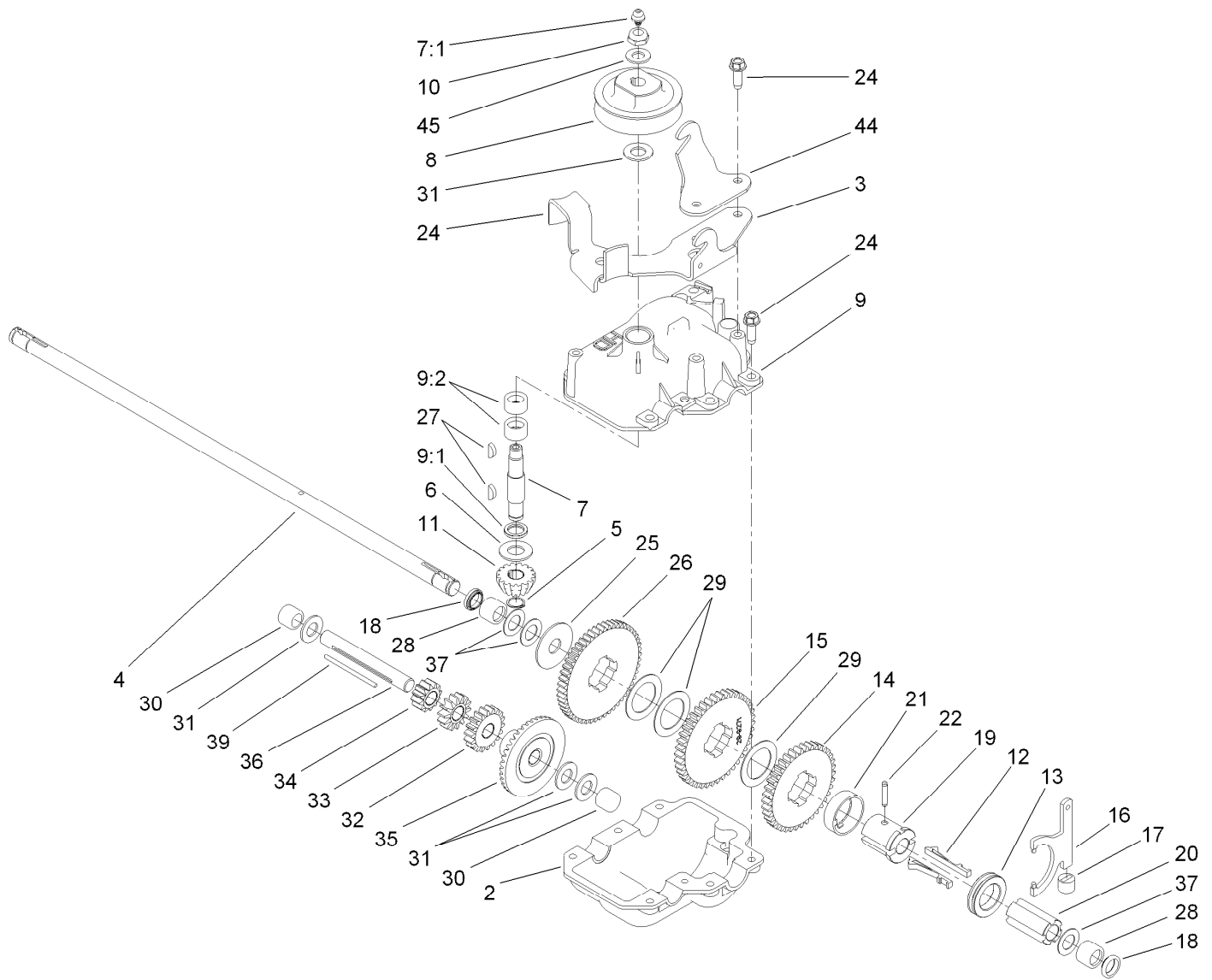

## Gear Case Assembly No. 74-1860

Ref.	Part Number	Qty.	Description	Ref.	Part Number	Qty.	Description
2	119-7863	1	Gearcase-Lower	20	39-6720	1	Sleeve
3	49-8461-03	1	Bracket-Guide, Belt	21	55-8020	1	Retainer-Key
4	74-1890	1	Shaft-Output	22	3285-19	1	Pin-Groove
5	32151-57	1	Ring-Retaining	24	49-2040	8	Screw-HWHTF
6	47-2910	1	Washer-Thrust	25	29-9690	1	Washer
7	13-5149	1	Input Shaft ASM	26	46-3560	1	Gear
7:1	302-63	1	Zerk	27	3257-1	2	Key-Woodruff
8	39-6740	1	Pulley	28	117-3500	2	Bearing-Caged Needle Roller
9	13-9739	1	Upper Gearcase ASM	29	36-4770	3	Washer
9:1	47-7260	1	Seal	30	252-103	2	Bearing-Needle, Closed
9:2	47-7270	2	Bearing-Needle	31	36-4792	4	Washer-Thrust
10	3296-5	1	Nut-Lock	32	39-6650	1	Gear-18T
11	39-6660	1	Pinion-Bevel	33	46-3550	1	Gear-14T
12	29-9330	2	Key-Shift	34	46-3540	1	Gear-12T
13	29-9340	1	Collar-Shift	35	74-1760	1	Gear-Bevel
14	42-4740	1	Gear-38T	36	53-7950	1	Shaft-Intermediate
15	29-9271	1	Gear-42T	37	36-4780	4	Washer-Plain
16	60-8870	1	Yoke-Shift	39	39-7842	1	Key
17	29-9570	1	Bushing-Yoke	44	74-1750-03	1	Bracket-Engage, Traction
18	47-6730	2	Seal-Oil	45	3256-45	1	Washer-Flat
19	55-8010	1	Sleeve-Gear				

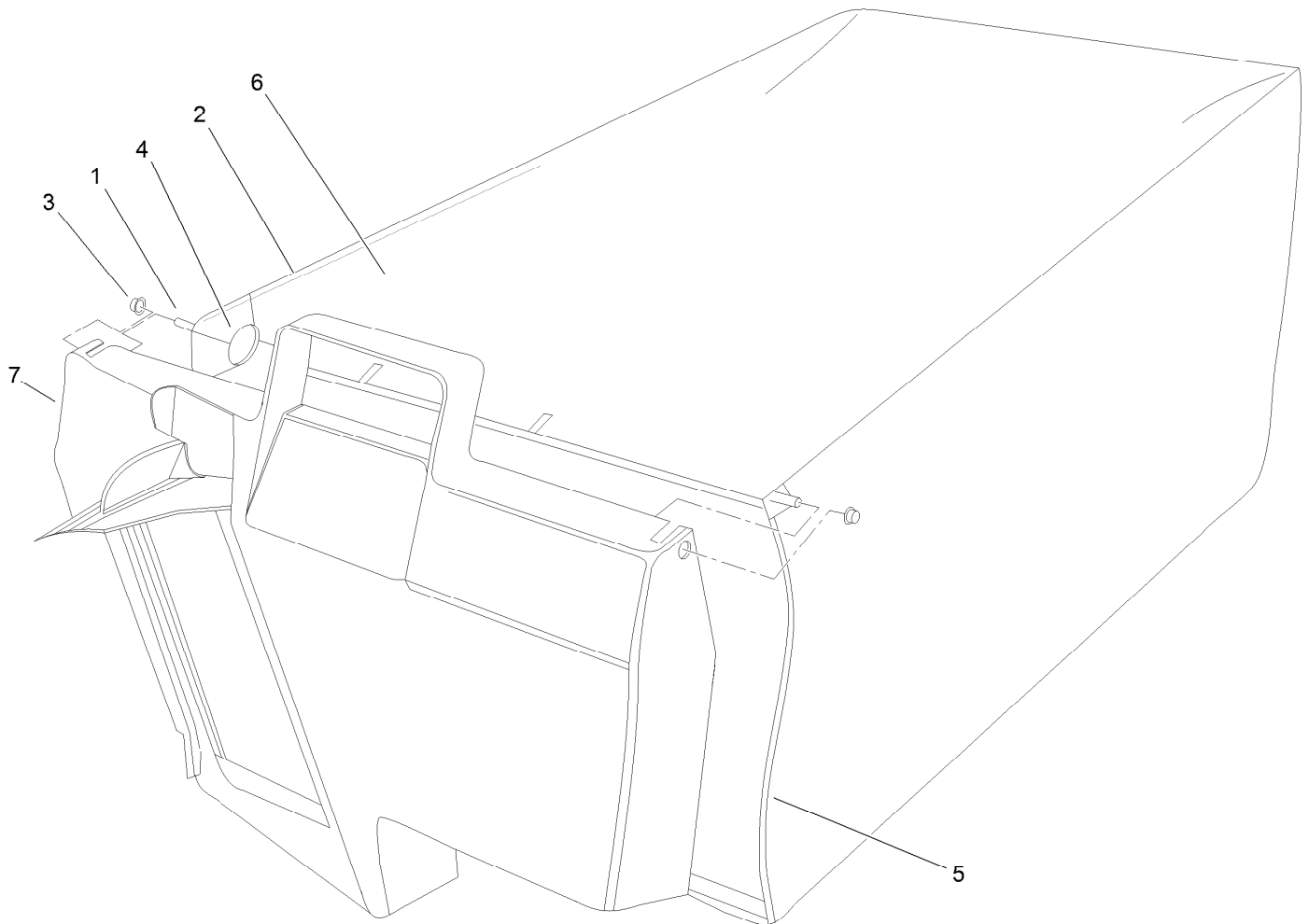

## Grass Bag Assembly No. 121-1391

<i>Ref.</i>	<i>Part Number</i>	<i>Qty.</i>	<i>Description</i>
1	33-4820	1	Hinge-Door, Bag
2	121-1388	1	Frame-Bag, Upper
3	3290-422	2	Nut-Push
4	36-6910	2	Spring
5	42-4020	1	Frame-Bag
6	106-0926	1	Bag-Grass
7	121-1389	1	Door-Bag, Grass

# Attachments and Accessories

## For 22196 21in Heavy-Duty Recycler/Rear Bagger Lawn Mower

<b>Product Name</b>	<b>Model/Part</b>
Blade-Atomic, 21in .....	104-1302
Bag-Large, Walk Behind (Toro).....	490-7315
Bag-Walk Behind (Toro).....	490-7318
Bag-Large, Walk Behind .....	490-7322
Bag-Walk Behind .....	490-7325
Cover-Lawnmower .....	490-7462
Side Discharge Kit .....	59199

**Notes:**

**Notes:**



**Count on it.**