



**Count on it.**

**Parts Catalog**

**Z Master® Professional 5000  
Series Riding Mower**

**with 72in TURBO FORCE® Side Discharge  
Mower**

**Model No. 74916—Serial No. 313000001 and Up**



# Ordering Replacement Parts

To order replacement parts, please supply the part number, the quantity, and the description of each part desired.

## Understanding Reference Numbers

Each identified part in an illustration has a reference number. The reference number for a part also appears in the parts list, along with other information about the part.

This catalog uses two special reference number formats, one to indicate parts in a service assembly and another to indicate the quantity of a given part in an illustration.

## Service Assembly Reference Numbers

Parts in service assemblies have reference numbers in the form a:b. The a represents the reference number of the entire service assembly and the b represents a sequential number unique to each part within the service assembly.

For example, a wheel assembly might be identified by reference number 6, the tire by 6:1, the valve by 6:2, and the wheel by 6:3. When you order the assembly identified by reference number 6, you receive all parts identified by reference numbers 6:1, 6:2, and 6:3. However, you may also order any part individually. Reference numbers of this type appear in illustration and in parts lists.

## Reference Numbers Indicating Quantity

In an illustration, if a reference number indicates more than one part, the reference number has the form nX y. The n represents the quantity of the part, the X is the multiplication symbol, and the y represents the reference number.

For example, in an illustration, the reference number 2X 37 means that two of the parts identified by reference number 37 are indicated.

# List of Abbreviations

<b>AR:</b> as required	<b>HLH:</b> hex lag head	<b>PTO:</b> power-take-off
<b>ASM:</b> assembly	<b>HOC:</b> height-of-cut	<b>RH:</b> right hand
<b>BBC:</b> blade brake control	<b>HSBH:</b> hex socket button head	<b>ROPS:</b> roll-over protection system
<b>BHTF:</b> button head thread forming	<b>HSFH:</b> hex socket flat head	<b>RRB:</b> rear roller brush
<b>CARR:</b> carriage	<b>HSH:</b> hex socket head	<b>SFH:</b> slotted fillister head
<b>CCW:</b> counter clockwise	<b>HWH:</b> hex washer head	<b>SHH:</b> slotted hex head
<b>CW:</b> clockwise	<b>HWHTF:</b> hex washer head thread forming	<b>SHWH:</b> slotted hex washer head
<b>DEG:</b> degrees	<b>HYD:</b> hydraulic	<b>SPH:</b> slotted pan head
<b>DPA:</b> Dual Point Adjustment	<b>LH:</b> left hand	<b>SQH:</b> square head
<b>ECM:</b> electronic control module	<b>LP:</b> Liquefied Petroleum Gas	<b>SRH:</b> slotted round head
<b>EXT:</b> external	<b>LPG:</b> Liquefied Petroleum Gas	<b>STD:</b> standard
<b>FH:</b> flat head	<b>NI:</b> nylon insert	<b>TAP:</b> self tapping
<b>GA:</b> gauge	<b>NPTF:</b> national pipe thread fine	<b>TTH:</b> torx truss head
<b>HD:</b> heavy-duty	<b>PFH:</b> phillips flat head	
<b>HF:</b> hex flange	<b>PPH:</b> phillips pan head	
<b>HH:</b> hex head	<b>PPHTF:</b> phillips pan head thread forming	
<b>HHF:</b> hex head flange	<b>PRH:</b> phillips round head	
<b>HHFTF:</b> hex head flange thread forming	<b>PTH:</b> phillips truss head	
<b>HJ:</b> hex jam		

# Contents

Frame and Caster Wheel Assembly .....	4
Roll-Over Protection System Assembly No. 116-0231 .....	6
Caster Wheel and Fork Assembly .....	7
Hydraulic Pump, Idler and Belt Assembly .....	8
Pump Idler Assembly No. 116-1255 .....	9
LH Hydro Assembly No. 116-6413 .....	10
RH Hydro Assembly No. 116-6414 .....	11
Rear Wheel and Park Brake Assembly .....	12
Parking Brake Handle Assembly No. 116-7551 .....	13
Fuel Tank Mounting Assembly .....	14
Fuel Tank Assembly No. 116-3979 .....	15
Seat Mount Assembly .....	16
Seat Assembly No. 125-3107 .....	17
Motion Control Assembly .....	18
Fender, Console and Control Assembly .....	19
LH Console Assembly No. 115-7401 .....	20
RH Console Assembly No. 115-7400 .....	21
Electrical Assembly .....	22
Decklift Assembly .....	23
Height-of-Cut Assembly No. 109-7438 .....	25
Engine, Muffler and Clutch Assembly .....	26
Deck Assembly .....	27
Deck Decal Assembly No. 114-5820 .....	29
Idler Assembly .....	30
Spindle Assembly No. 119-8560 .....	31
Rubber Deflector Assembly No. 108-2792 .....	32
Attachments and Accessories .....	33

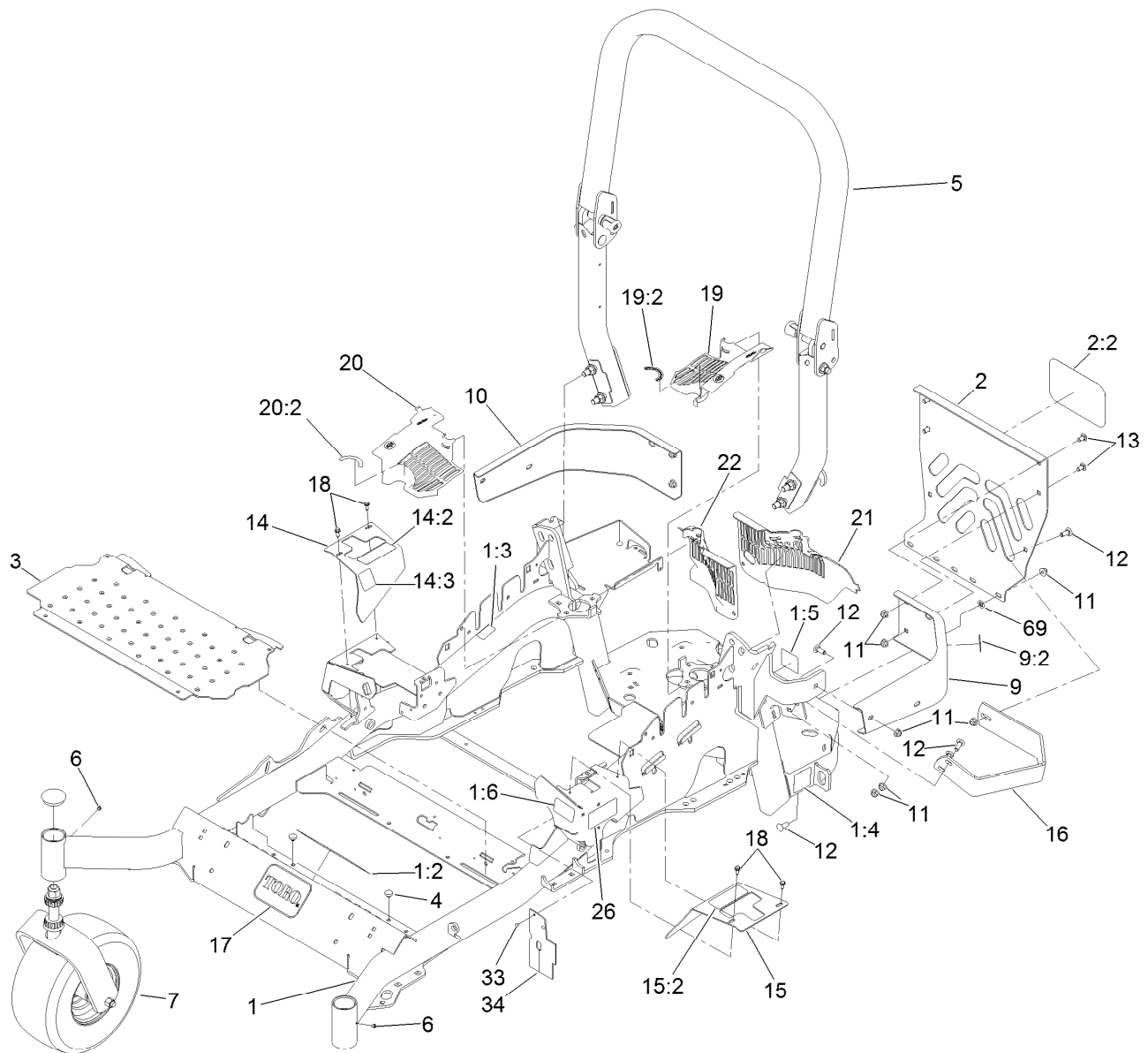

## Frame and Caster Wheel Assembly

Ref.	Part Number	Qty.	Description	Ref.	Part Number	Qty.	Description
1	116-5904	1	Mainframe ASM	13	3231-21	4	Screw-CARR
1:2	103-2076	2	Decal-Caution	14	116-5899	1	RH Motion Control Cover ASM
1:3	116-3303	1	Decal-Slope	14:2	109-7232	1	Decal-Motion Control
1:4	116-0205	2	Decal-Belt Drive	14:3	116-5944	1	Decal-Park Brake
1:5	116-4858	1	Decal-Spark Arrester	15	116-0580	1	LH Motion Control Cover ASM
1:6	116-1654	1	Decal-Fuel Fill	15:2	109-7232	1	Decal-Motion Control
2	115-7410	1	Rear Guard ASM	16	116-0043-03	1	Guard-Muffler
2:2	67-7320	1	Decal	17	68-3640	1	Decal
3	116-8898-01	1	Floorpan	18	32144-10	4	Screw-HWH
4	1-513658	2	Bumper	19	116-0170	1	LH Hydro Guard ASM
5	116-0231	1	ROPS ASM	19:2	116-0157	1	Decal-Hydro Oil
6	1-811010	2	Plug	20	116-0171	1	RH Hydro Guard ASM
7		2	Caster Wheel ASM ●	20:2	116-0157	1	Decal-Hydro Oil
9	116-0180	1	LH Bumper ASM	21	109-9057	1	Guard-Hydro, Rear LH
9:2	103-2076	1	Decal-Caution	22	109-9058	1	Guard-Hydro, Rear RH
10	116-0057-03	1	Bumper-RH	26	120-5894	2	Decal
11	104-8301	11	Nut-Flange, NI				
12	3231-22	7	Screw-CARR				

● Not serviced separately

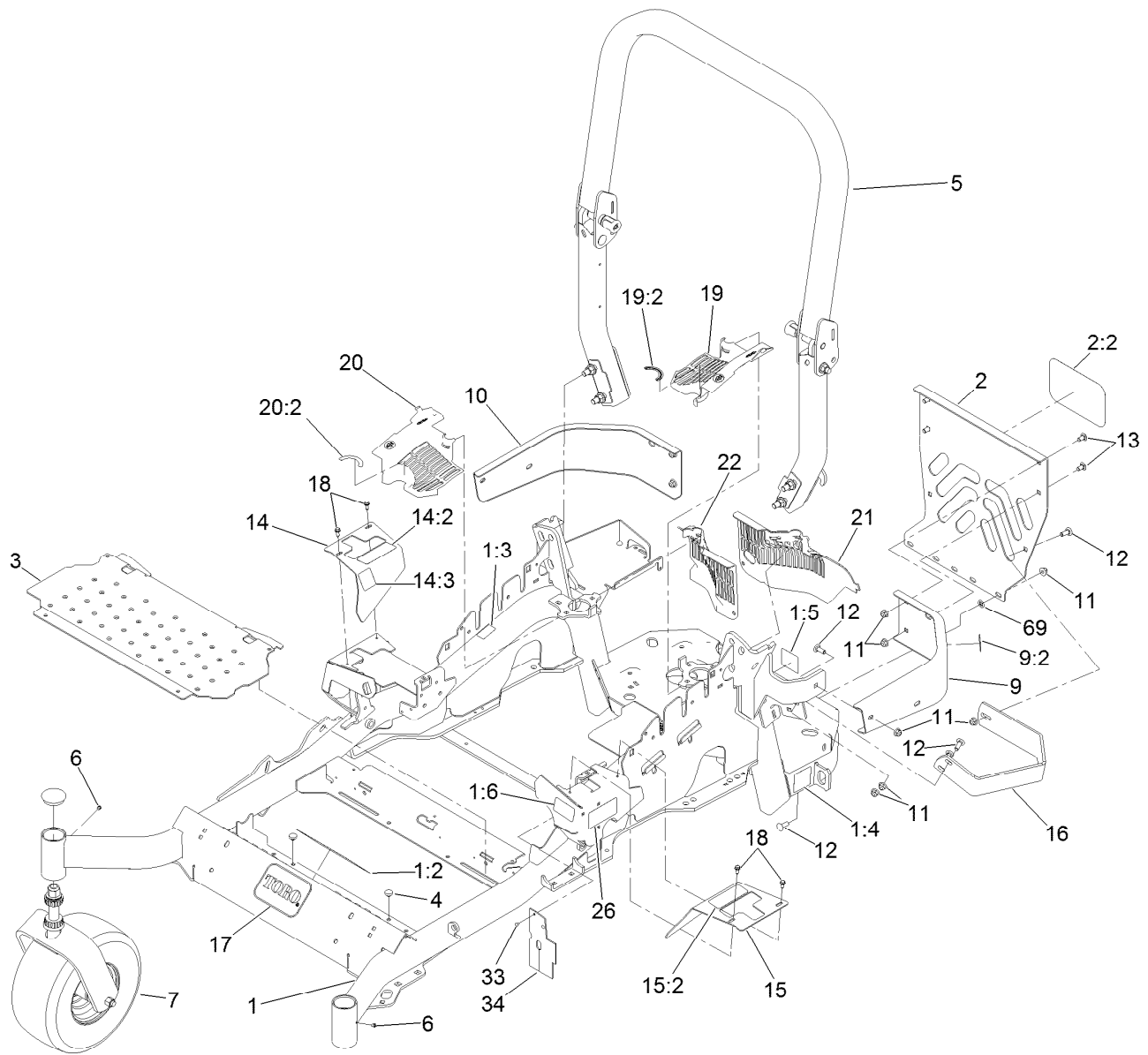

## Frame and Caster Wheel Assembly (continued)

Ref.	Part Number	Qty.	Description
33	1-803035	2	Rivet-Pop

Ref.	Part Number	Qty.	Description
34	116-2362	1	Deflector-Air Flow
69	107-3154	2	Nut-Push

● Not serviced separately

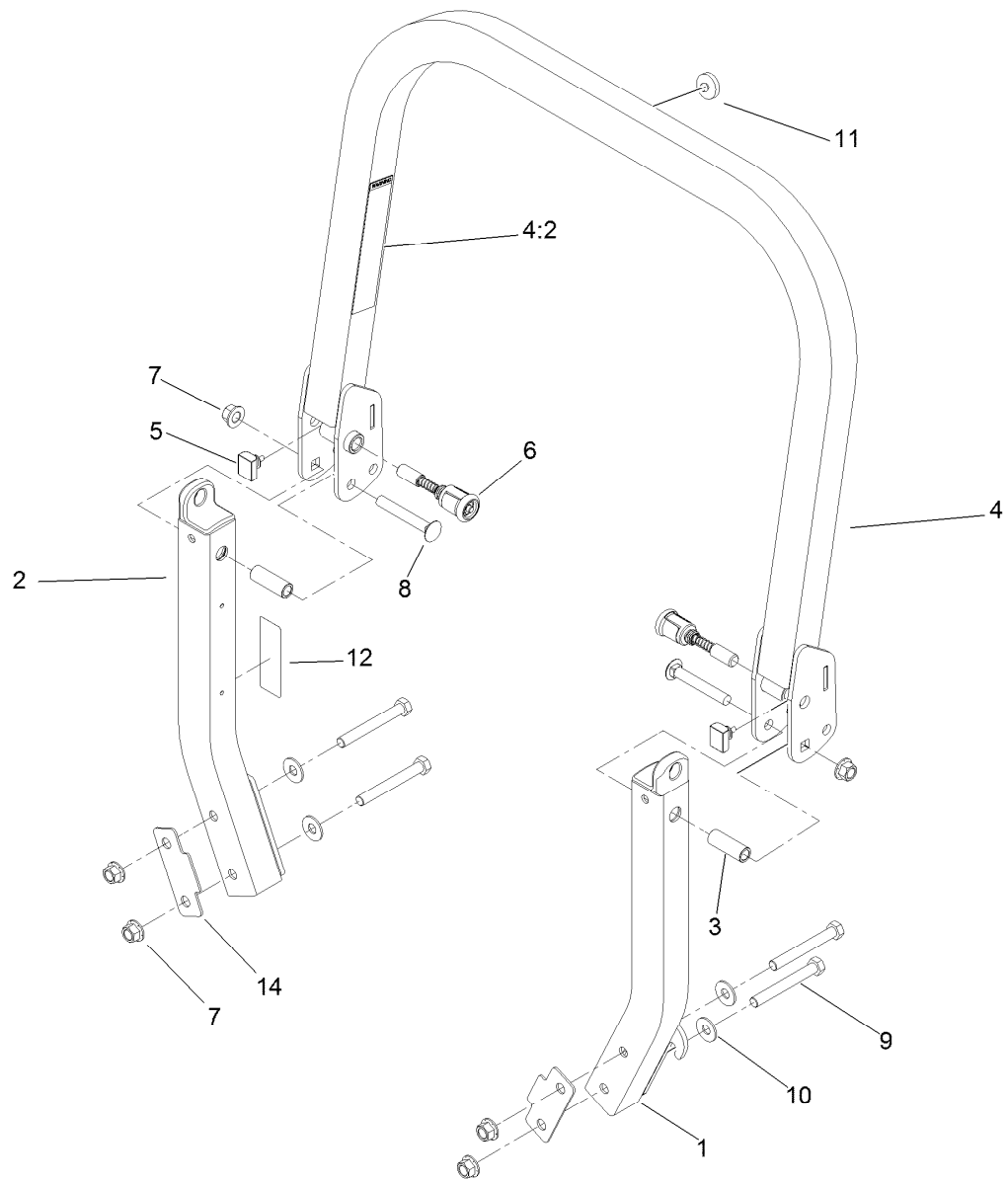

## Roll-Over Protection System Assembly No. 116-0231

Ref.	Part Number	Qty.	Description
1		1	LH ROPS Leg ASM ●
2		1	RH ROPS Leg ASM ●
3	109-6653	2	Spacer
4		1	Upper ROPS ASM ●
4:2	107-2102	1	Decal-Warning, Folding ROPS
5	109-5337	2	Bumper-ROPS
6	116-0104	2	Spring Pin ASM
7	99-5107	6	Nut-Lock
8	3233-10	2	Screw-CARR
9	325-17	4	Screw-HH
10	109-9505	4	Washer-Spring
11	109-9233	1	Bumper-Push-In, Rubber
12	116-0090	1	Decal-Caution
14	116-0960	2	Spacer

● Not serviced separately

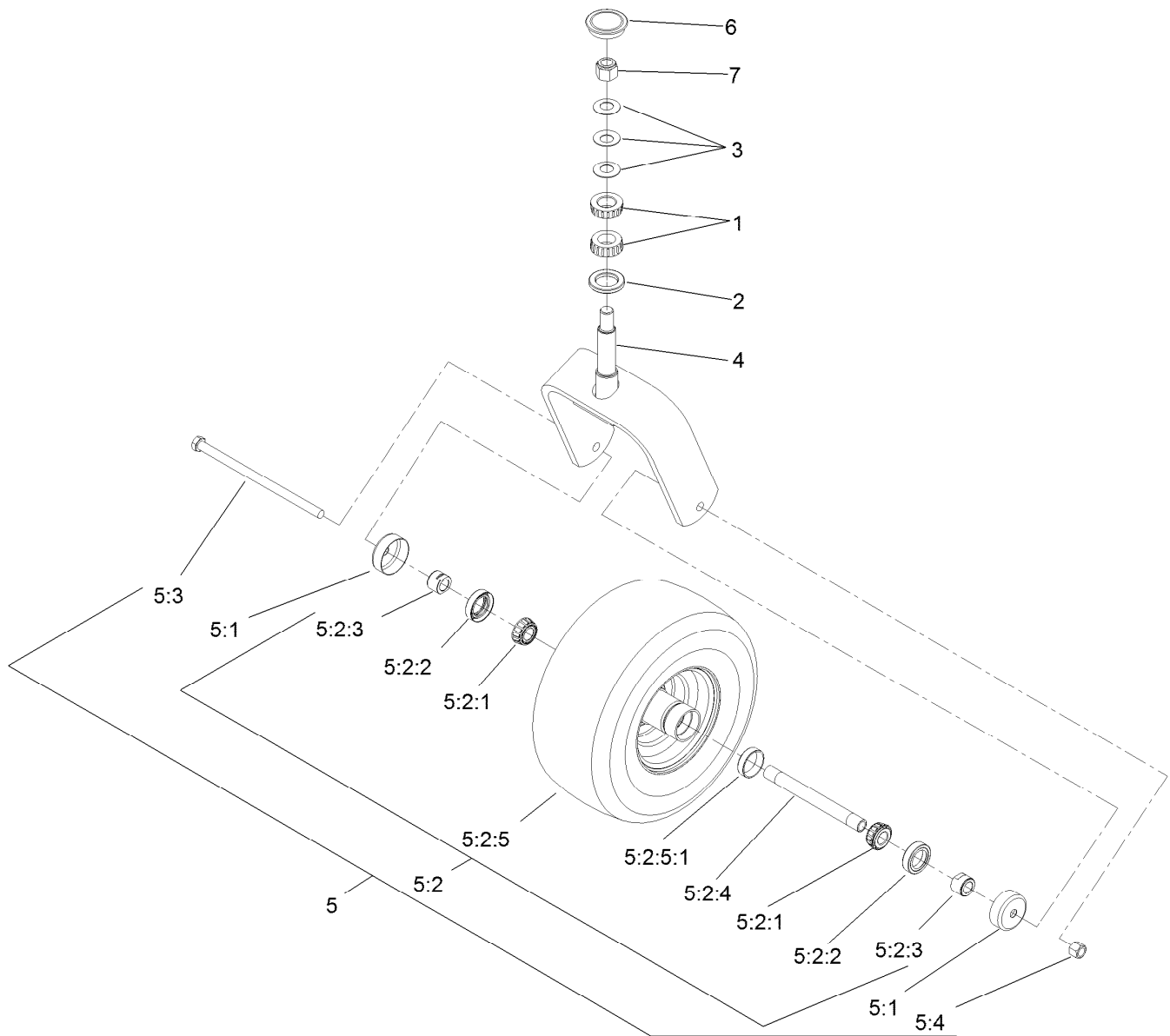

## Caster Wheel and Fork Assembly

Ref.	Part Number	Qty.	Description	Ref.	Part Number	Qty.	Description
1	1-543509	2	Bearing-Roller, Tapered	5:2:3	103-3051	2	Spacer-Nut ■
2	116-5647	1	Seal-Grease	5:2:4	103-5156	1	Axle-Caster
3	1-633508	3	Washer-Bellville	5:2:5		1	Wheel And Tire ASM ●
4	116-6707-01	1	Caster	5:2:5:1	1-633584	1	Bearing-Cup
5	109-9127	1	Wheel And Tire ASM	5:3	325-39	1	Screw-HH
5:1	103-2768	2	Guard-Seal	5:4	3296-23	1	Nut-Lock, NI
5:2		1	Wheel And Tire ASM ●	6	103-4882	1	Cap-Grease
5:2:1	1-633585	2	Bearing-Cone, Taper	7	3296-51	1	Nut-Lock, NI
5:2:2	103-0063	2	Seal-Caster				

● Not serviced separately

■ Use Pro-Lock, Nut Type (P/N 1-840022, .5ml tube) on threads.

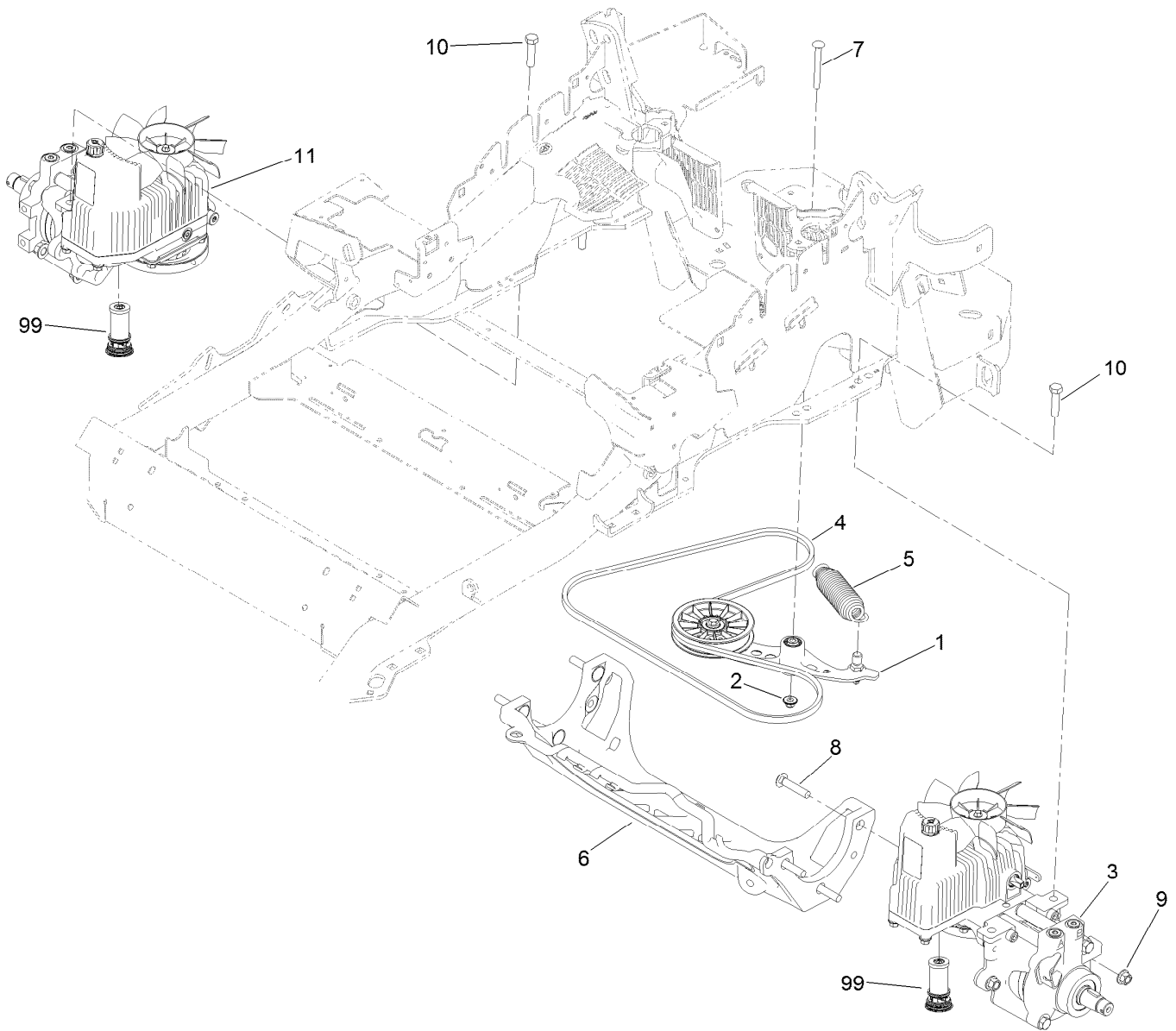

## Hydraulic Pump, Idler and Belt Assembly

Ref.	Part Number	Qty.	Description
1	116-1255	1	Pump Idler ASM
2	109-6658	1	Nut-Flange, NI
3	116-6413	1	LH Hydro ASM (12Cc W/Shock)
4	109-3388	1	Belt
5	116-6317	1	Spring-Extension
6	109-9375	1	Cradle-Hydro
7	116-1502	1	Bolt-Shoulder, Carriage
8	3233-34	6	Screw-CARR
9	99-5107	6	Nut-Lock
10	325-8	4	Screw-HH
11	116-6414	1	RH Hydro ASM (12Cc W/Shock)
99	114-4713	1	Hypr-Oil 500 (Quart) ●
99	114-4714	1	Hypr-Oil 500 (Gallon) ●
99	114-4715	1	Hypr-Oil 500-5 (5 Gallon) ●
99	117-0390	1	Filter-Hydro

● Not illustrated

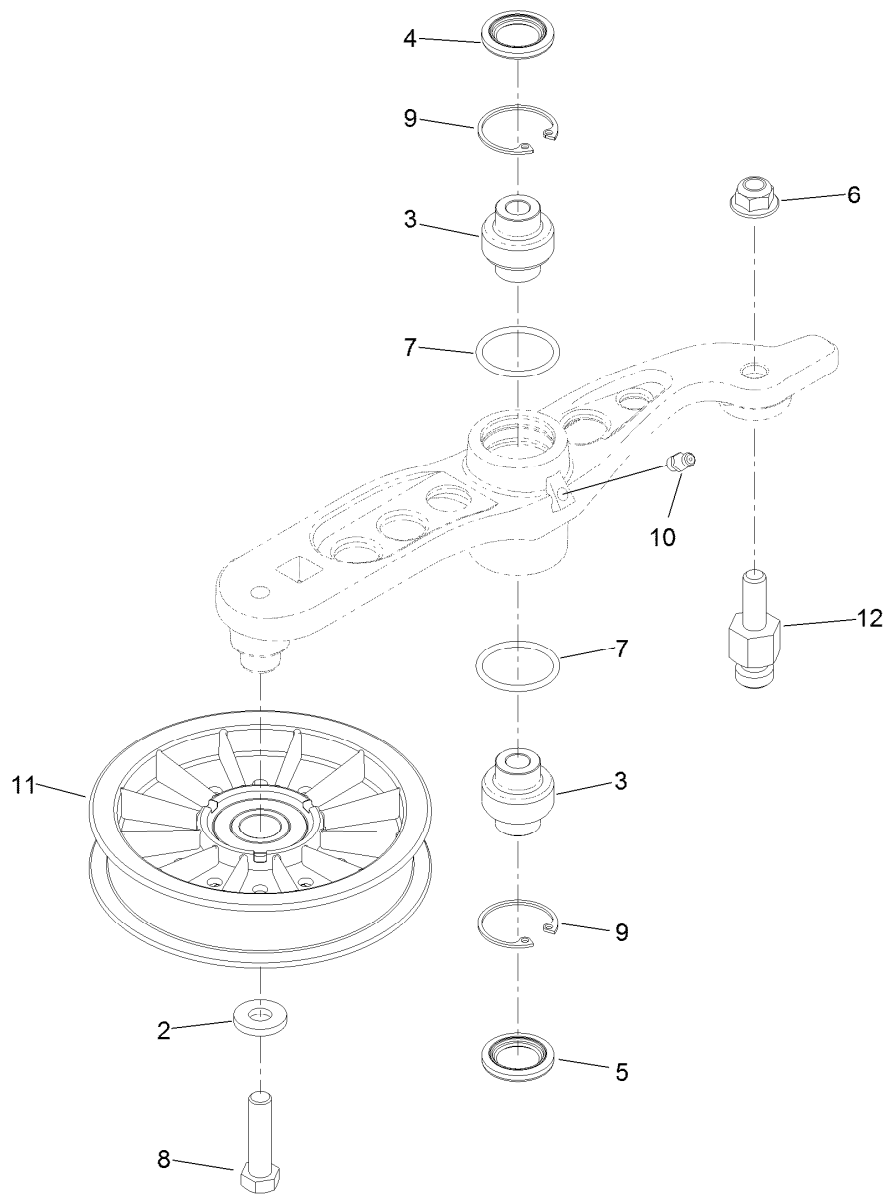

## Pump Idler Assembly No. 116-1255

Ref.	Part Number	Qty.	Description
2	43-0940	1	Spacer
3	103-3504	2	Bearing-Spherical
4	103-3505	1	Seal-Double Lip
5	103-3506	1	Seal-Single Lip
6	109-6658	1	Nut-Flange, NI
7	106-7159	2	O-Ring
8	323-8	1	Screw-HH
9	32120-10	2	Ring-Snap
10	302-19	1	Fitting-Grease
11	109-8076	1	Pulley-Idler
12	116-3467	1	Pin-Spring, Anchor

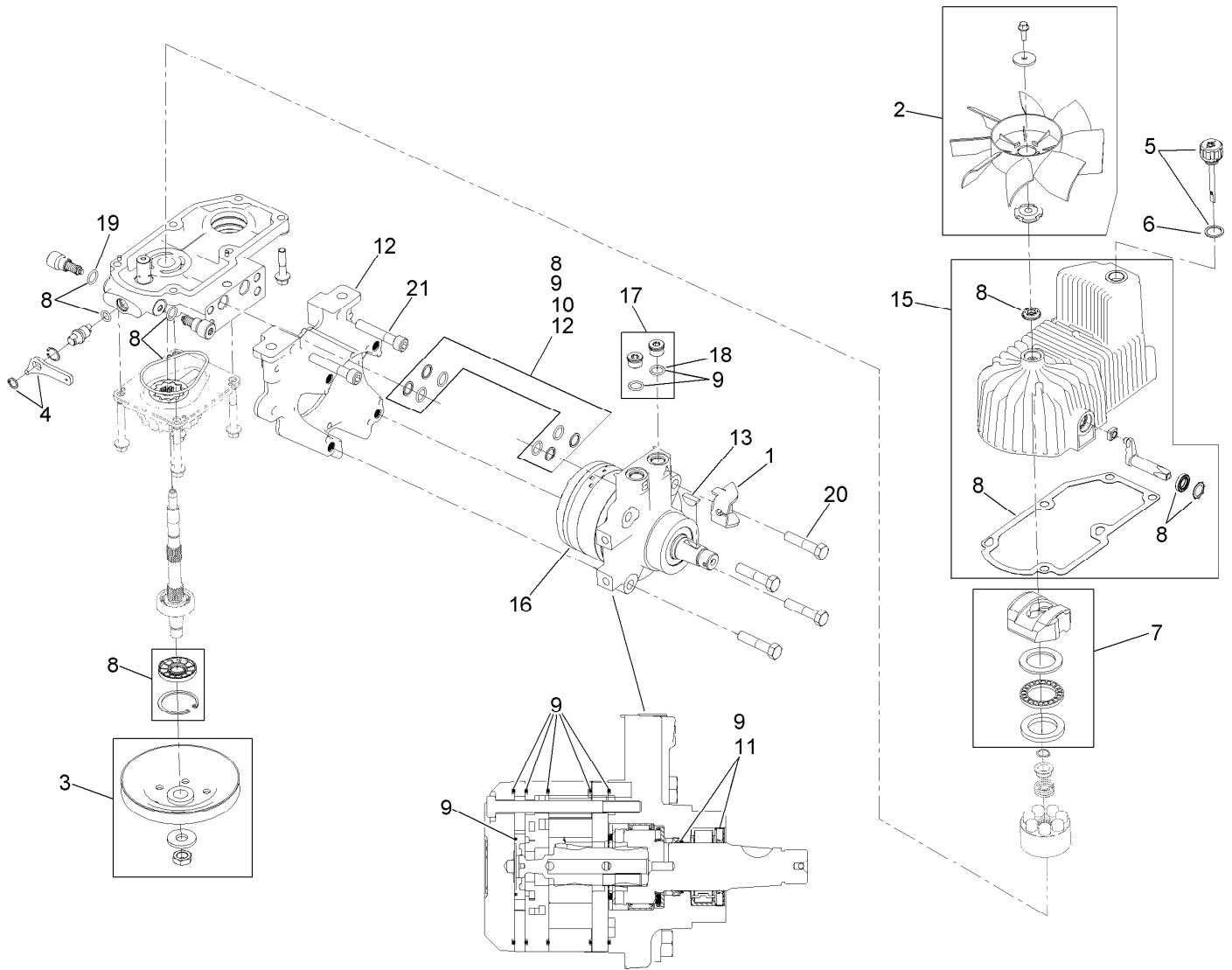

## LH Hydro Assembly No. 116-6413

Ref.	Part Number	Qty.	Description	Ref.	Part Number	Qty.	Description
1	116-6859	1	Bracket-Anchor, Cable	11	116-1371	1	Output Shaft Seal Kit
2	116-0233	1	Fan Kit	12	116-5469	1	Nose Cup-Uht
3	116-0234	1	Pulley Kit	13	3257-42	1	Key-Woodruff
4	116-0235	1	Handle-Bypass Valve, Hydro	15	116-3287	1	Housing-Hydro, LH
5	116-0236	1	Dipstick-Hydro W/Gasket	16	116-8915	1	Motor-Hydraulic LH 240Cc
6	116-0237	1	Gasket-Dipstick, Hydro	17	116-7901	1	Magnetic Plugs Service Kit
7	116-1367	1	Swash Block Kit	18	76-1900	2	O-Ring
8	116-1368	1	Pump Seal Kit	19	116-8662	2	O-Ring-Check Valve
9	116-1369	1	Motor Seal Kit	20	116-8974	4	Screw HH
10	116-1370	1	Tube Seal Kit	21	116-8975	2	Screw-HSH
				99	116-1373	1	Flow Test Kit ●

● Not illustrated

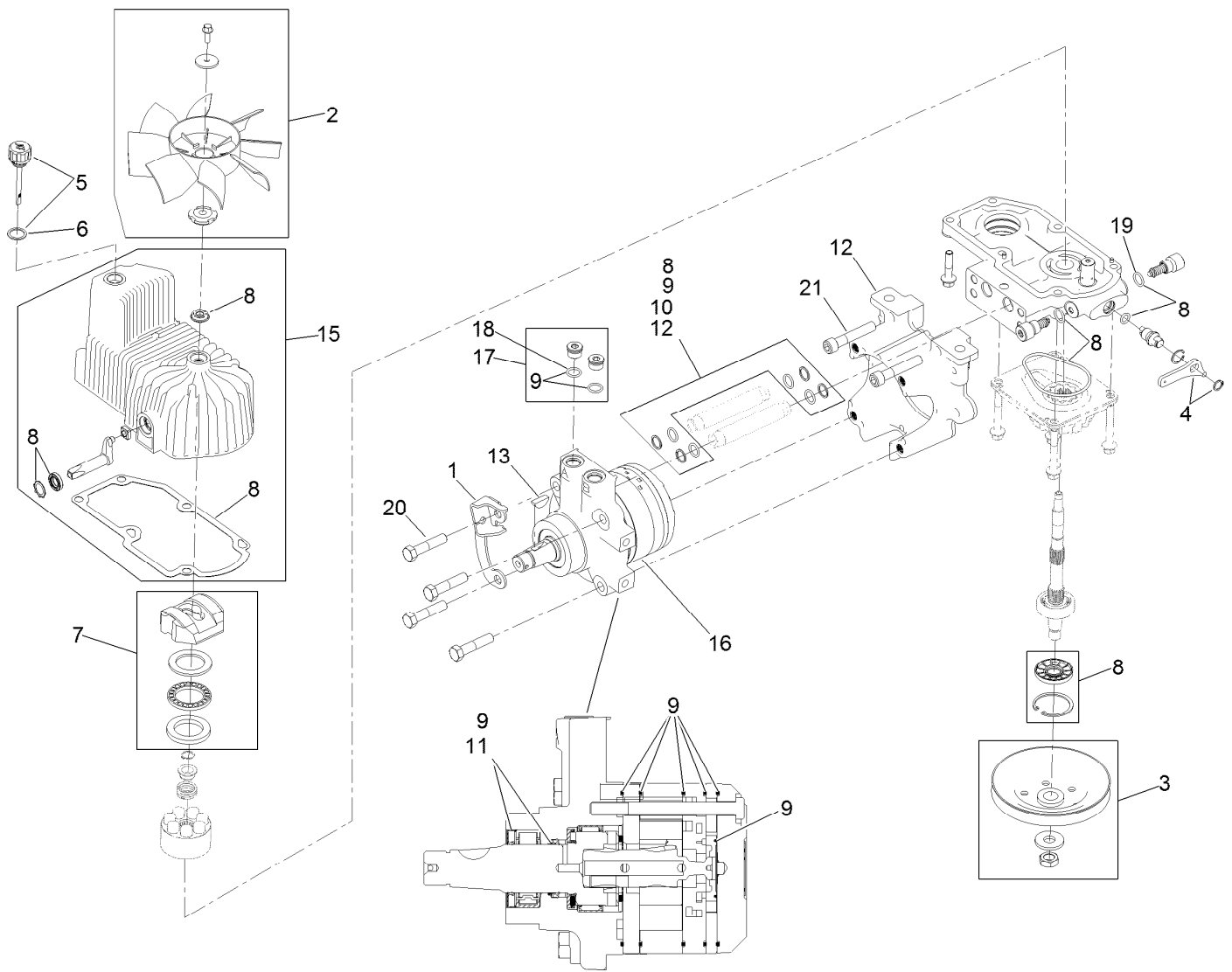

## RH Hydro Assembly No. 116-6414

<i>Ref.</i>	<i>Part Number</i>	<i>Qty.</i>	<i>Description</i>	<i>Ref.</i>	<i>Part Number</i>	<i>Qty.</i>	<i>Description</i>
1	116-6859	1	Bracket-Anchor, Cable	11	116-1371	1	Output Shaft Seal Kit
2	116-0233	1	Fan Kit	12	116-5469	1	Nose Cup-Uht
3	116-0234	1	Pulley Kit	13	3257-42	1	Key-Woodruff
4	116-0235	1	Handle-Bypass Valve, Hydro	15	116-3288	1	Housing-Hydro, RH
5	116-0236	1	Dipstick-Hydro W/Gasket	16	116-8916	1	Motor-Hydraulic RH 240Cc
6	116-0237	1	Gasket-Dipstick, Hydro	17	116-7901	1	Magnetic Plugs Service Kit
7	116-1367	1	Swash Block Kit	18	76-1900	2	O-Ring
8	116-1368	1	Pump Seal Kit	19	116-8662	2	O-Ring-Check Valve
9	116-1369	1	Motor Seal Kit	20	116-8974	4	Screw HH
10	116-1370	1	Tube Seal Kit	21	116-8975	2	Screw-HSH
				99	116-1373	1	Flow Test Kit ●

● Not illustrated

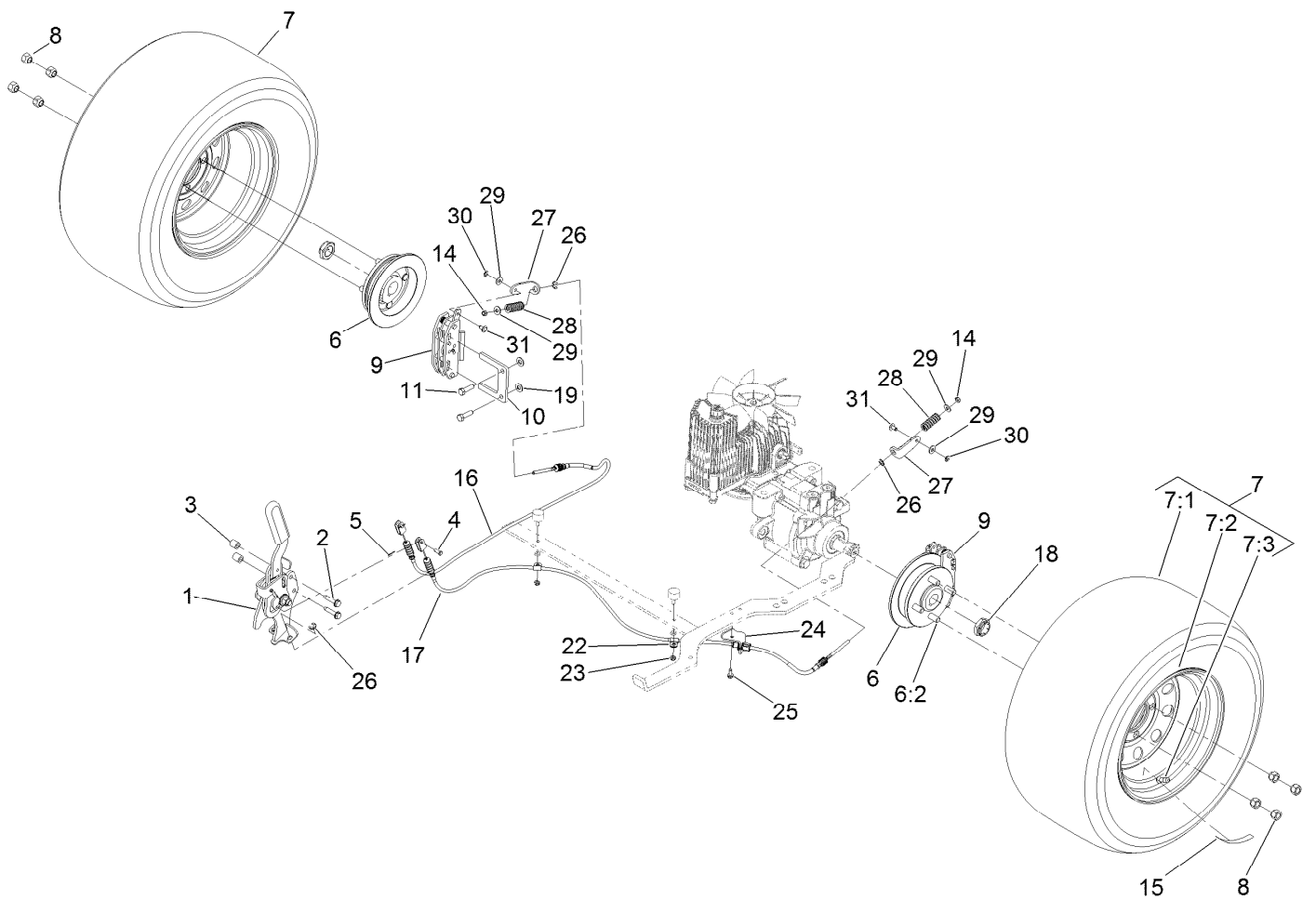

## Rear Wheel and Park Brake Assembly

Ref.	Part Number	Qty.	Description	Ref.	Part Number	Qty.	Description
1	116-7551	1	Brake Handle ASM	15	116-2643	2	Decal-Wheel Nut Torque
2	32144-57	2	Screw	16	116-6364	1	Cable-Park Brake, RH
3	82-6840	2	Spacer	17	116-6365	1	Cable-Park Brake, LH
4	60-1730	2	Pin-Clevis	18	116-1399	2	Locknut
5	3272-1	2	Pin-Cotter	19	3256-24	4	Washer-Flat
6	116-1746	2	Wheel Hub ASM	22	88-7970	2	Clip
6:2	116-1696	4	Stud-Wheel	23	3296-56	2	Nut-Lock, NI
7	109-8972	2	Wheel And Tire ASM	24	116-6397	1	Bracket-Cable
7:1	1-633993	1	Tire	25	32144-10	1	Screw-HWH
7:2	109-3156	1	Rim ASM	26	32120-18	4	E-Ring
7:3	232-27	1	Stem-Valve	27	116-6182	2	Bracket-Brake, L
8	242-50	8	Nut-Lug	28	116-6347	2	Spring-Die
9	109-2889	2	Caliper-Brake	29	3256-22	4	Washer-Flat
10	109-0958	2	Plate-Mount, Brake	30	32151-86	2	E-Ring
11	92-5727	4	Screw-Lock, Patch	31	116-6348	2	Pin-Brake
14	3296-13	2	Nut-Lock, NI				

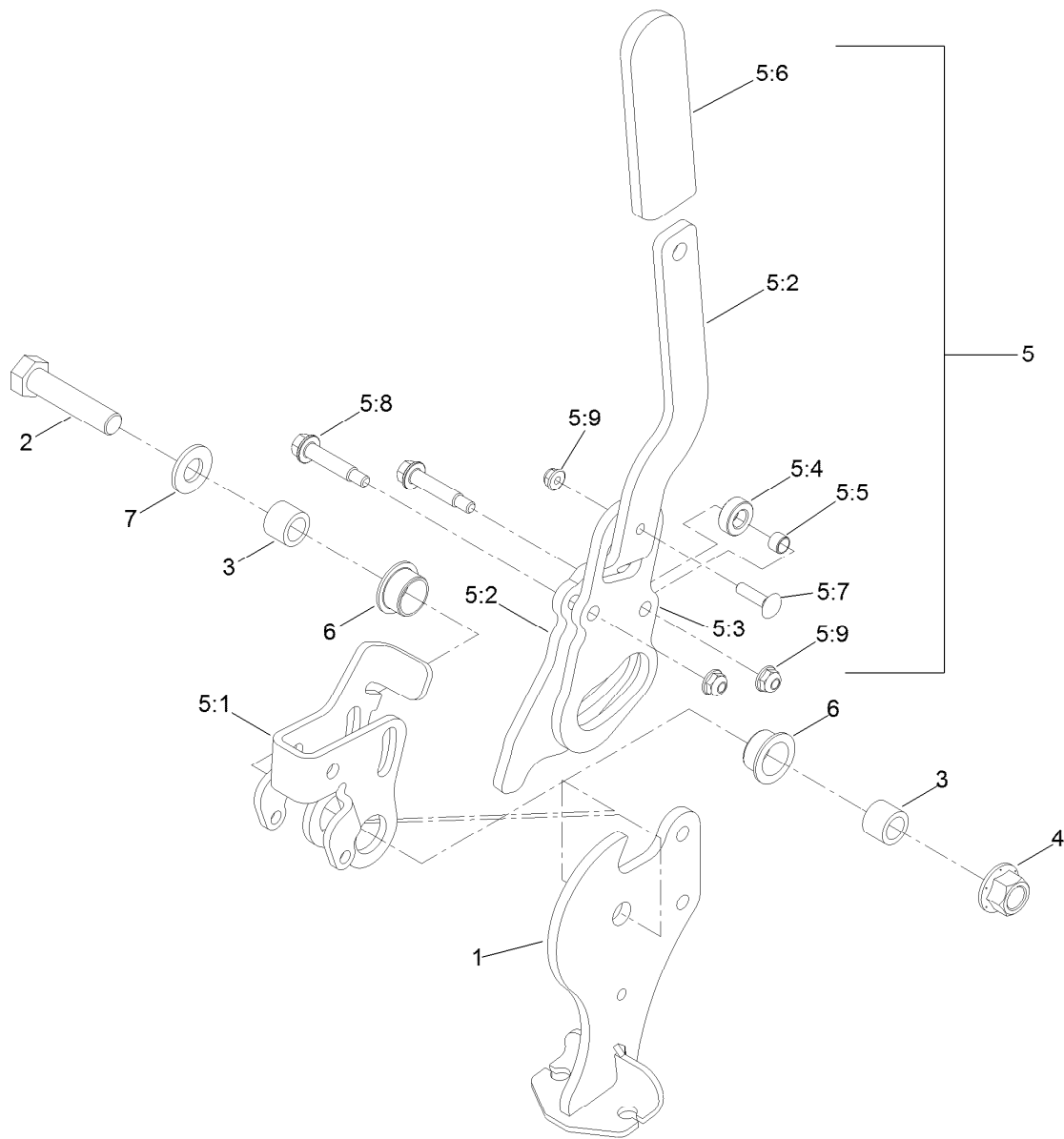

## Parking Brake Handle Assembly No. 116-7551

<i>Ref.</i>	<i>Part Number</i>	<i>Qty.</i>	<i>Description</i>
1	116-7263	1	Brake Pivot ASM
2	325-9	1	Screw-HH
3	116-5384	2	Spacer
4	99-5107	1	Nut-Lock
5	116-6860	1	Handle ASM
5:1	116-6856	1	Bellcrank-Brake
5:2	116-6857	1	Handle-Brake
5:3	116-6858	1	Plate-Handle

<i>Ref.</i>	<i>Part Number</i>	<i>Qty.</i>	<i>Description</i>
5:4	116-6846	1	Roller-Brake
5:5	116-6852	1	Bearing-Sleeve
5:6	1-633268	1	Grip-Lever
5:7	3229-2	1	Screw-CARR
5:8	116-6876	2	Screw-Shoulder
5:9	104-7201	3	Nut-HF
6	109-8054	2	Bushing-Flange
7	3256-26	1	Washer-Flat

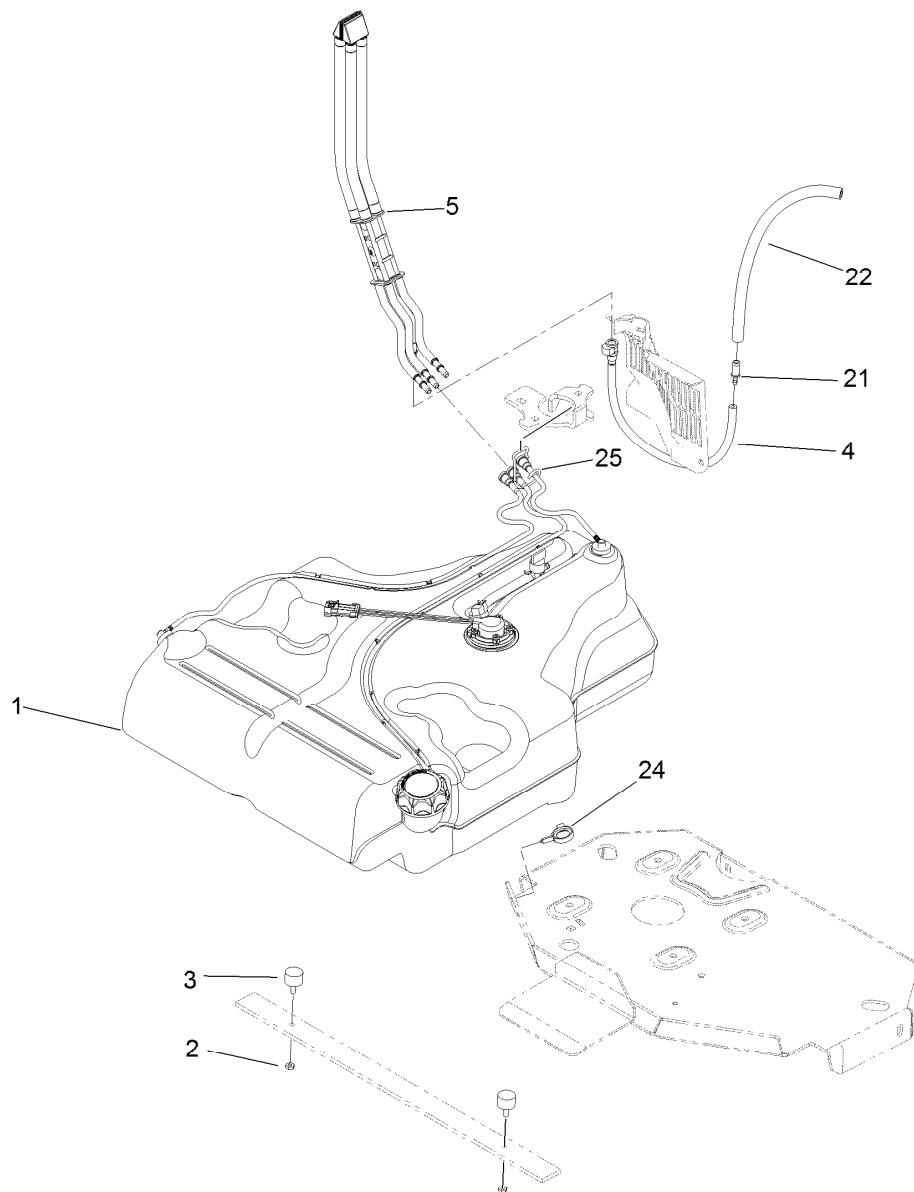

## Fuel Tank Mounting Assembly

Ref.	Part Number	Qty.	Description
1	116-3979	1	Fuel Tank ASM
2	3218-1	2	Nut-Jam
3	116-6380	2	Bumper-Rubber (W/ Stud)
4	116-3977	1	Hose ASM
5	109-9491	1	Fuel Manifold Vent ASM
21	98-2952	1	Fitting-Straight
22	116-5087	1	Hose-Fuel
24	105-1853	1	Clamp-Hose
25	116-6005	1	Retainer-Vapor Line

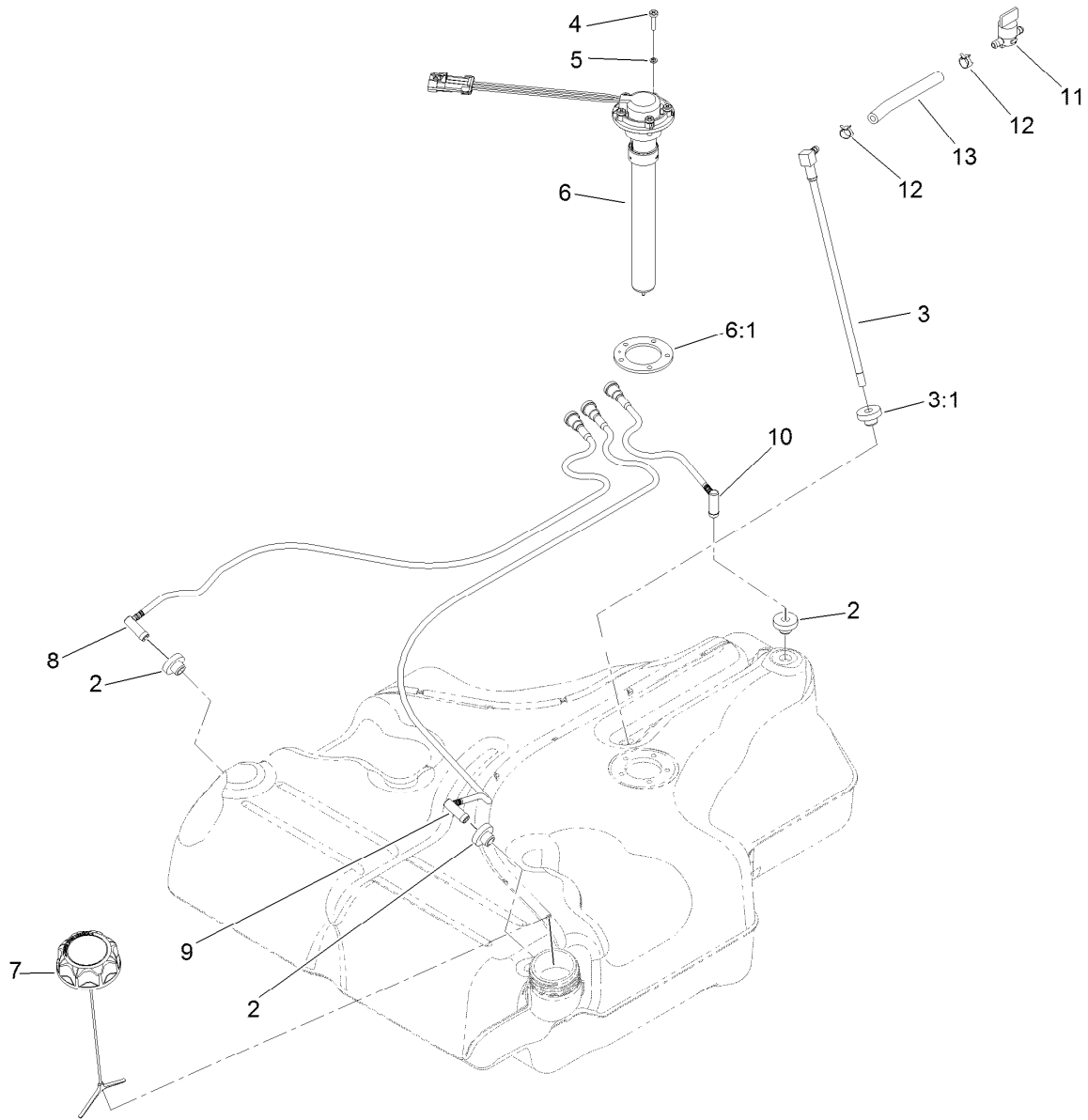

## Fuel Tank Assembly No. 116-3979

Ref.	Part Number	Qty.	Description
2	46-6560	4	Bushing
3	116-2459	1	Fuel Line Kit (With Grommet)
3:1	46-6560	1	Bushing
4	9107944	5	Screw-Pan
5	3253-17	5	Washer-Lock
6	116-0003	1	Sender-Fuel Level
6:1	109-9620	1	Gasket-Sender, Fuel
7	116-1704	1	Cap-Fuel, Ratcheting
8	116-2460	1	RH Vent Line Kit (With Grommet)
9	116-2461	1	LH Vent Line Kit (With Grommet)
10	116-2462	1	Rear Vent Line Kit (With Grommet)
11	1-603770	1	Valve-Fuel
12	2412-98	2	Clamp-Hose
13	109-0650	1	Hose-Fuel

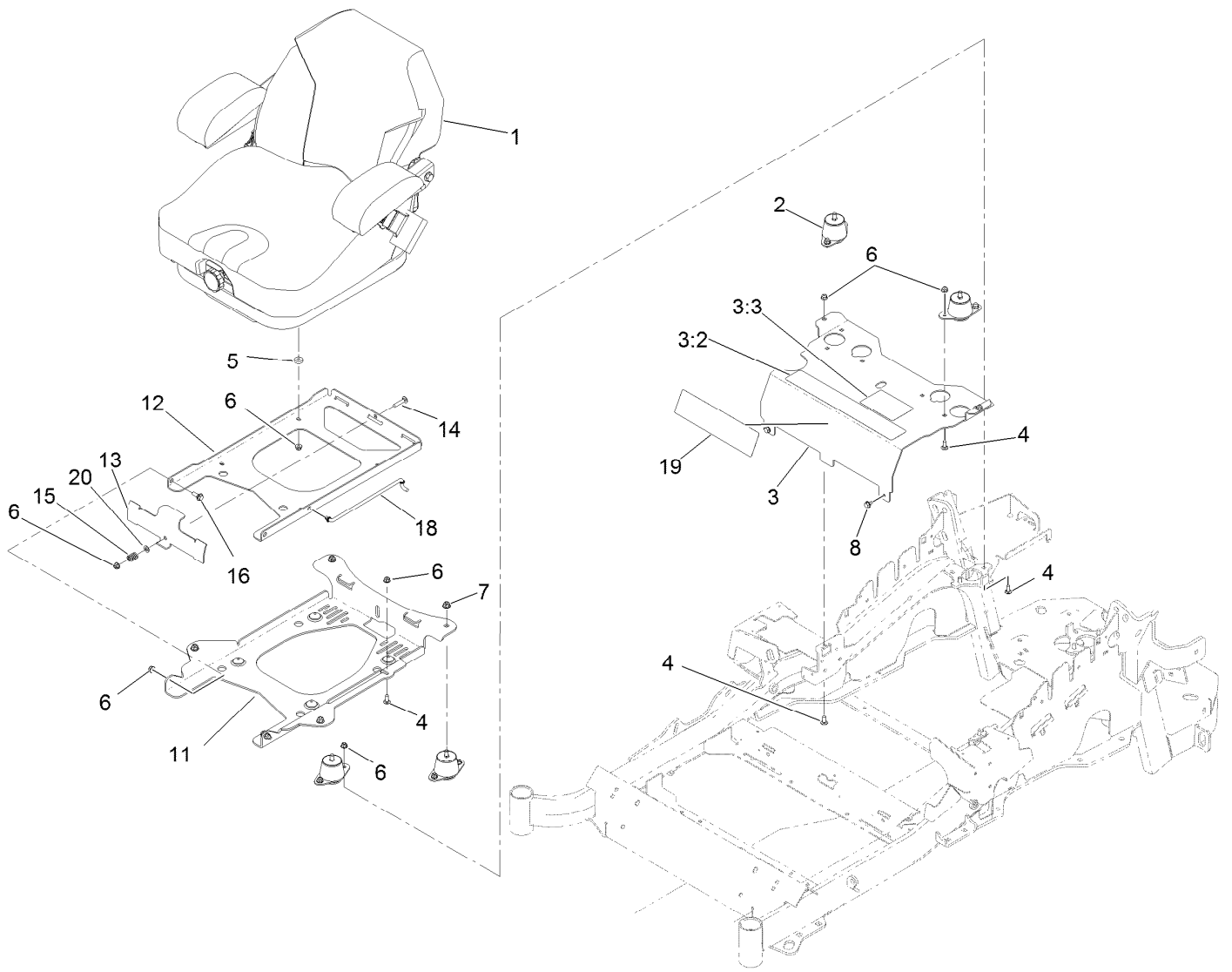

## Seat Mount Assembly

<i>Ref.</i>	<i>Part Number</i>	<i>Qty.</i>	<i>Description</i>	<i>Ref.</i>	<i>Part Number</i>	<i>Qty.</i>	<i>Description</i>
1	125-3107	1	Suspension Seat ASM	11	116-3860-03	1	Plate-Tilt, Seat Support
2	109-9034	4	Isolator-Seat	12	116-3859-03	1	Plate-Seat, Frame
3	116-2323	1	Mount-Seat	13	109-9881-03	1	Plate-Latch, Seat
3:2	109-7069	1	Decal-Console	14	3230-4	1	Screw-CARR
3:3	116-0211	1	Decal-Service Aid	15	107-3017	1	Spring-Compression
4	3230-23	11	Screw-CARR	16	116-1297	2	Screw-Shoulder
5	26-4840	4	Spacer-Pin, Mounting	18	116-0070	1	Rod-Prop
6	104-8300	18	Nut-Flange, NI	19	120-5893	1	Decal
7	104-8301	4	Nut-Flange, NI	20	3256-23	1	Washer-Flat
8	9266934	2	Screw				

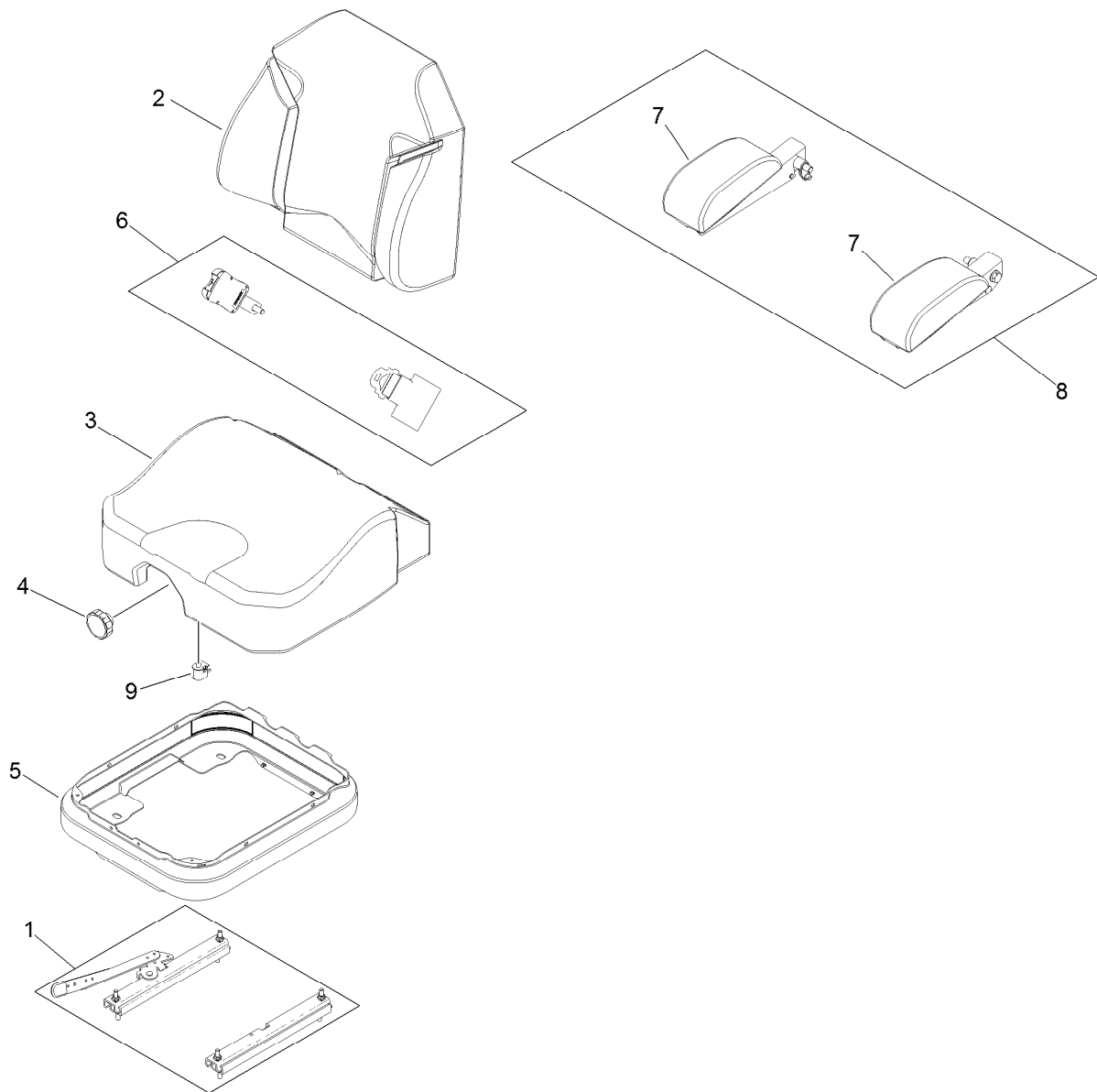

## Seat Assembly No. 125-3107

<i>Ref.</i>	<i>Part Number</i>	<i>Qty.</i>	<i>Description</i>
1	116-8910	1	Seat Track Set
2	125-3112	1	Cover-Back
3	125-3111	1	Cover-Cushion
4	116-5658	1	Knob-Adjuster
5	116-5659	1	Cover-Suspension Bellows
6	109-9805	1	Seat Belt Kit
7	125-3143	1	Arm Rest Pad Set
8	125-3144	1	Arm Rest Set
9	82-2190	1	Switch-Bail

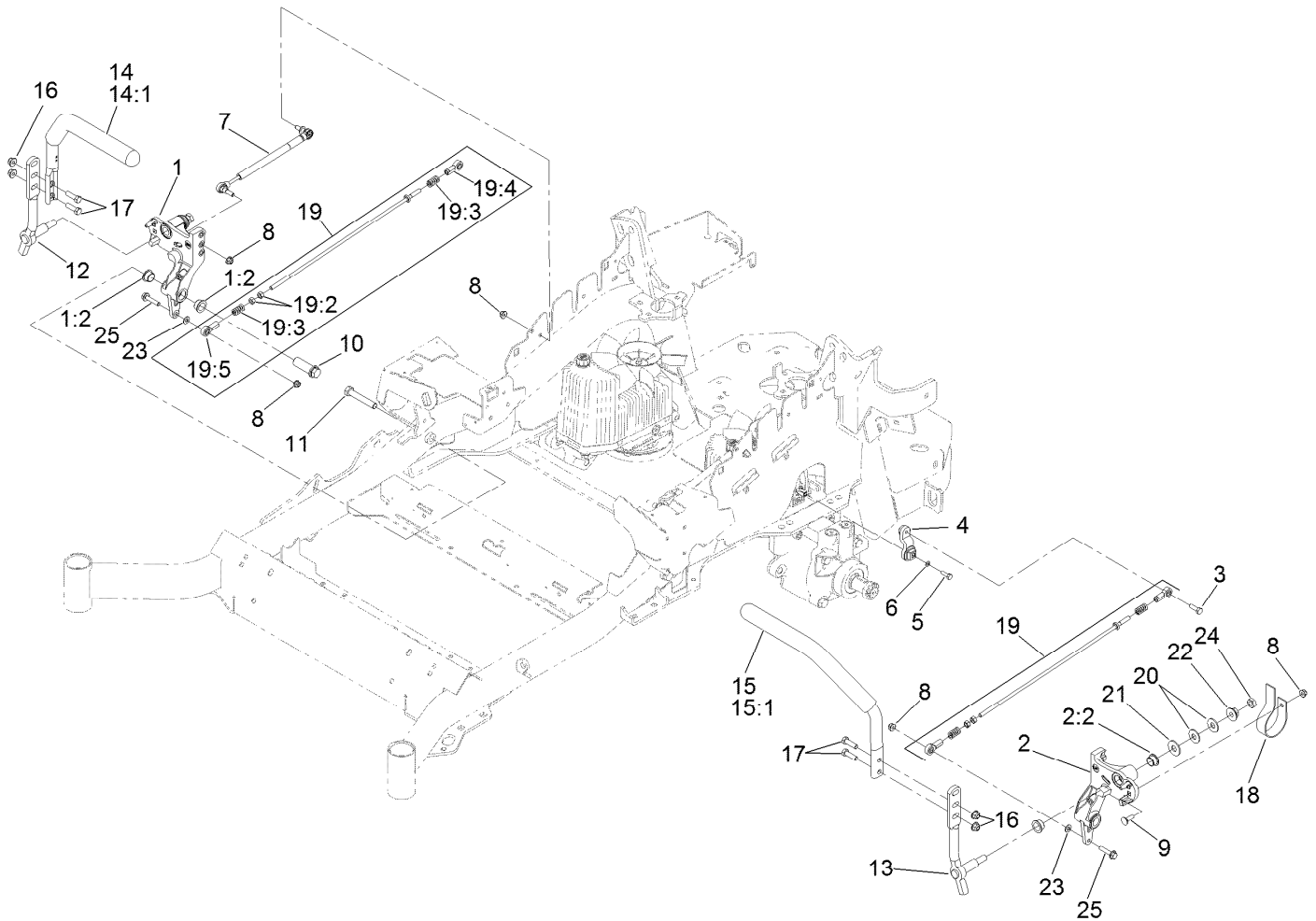

## Motion Control Assembly

Ref.	Part Number	Qty.	Description	Ref.	Part Number	Qty.	Description
1	116-0880	1	RH Motion Control And Bushing ASM	14	109-6589	1	RH Steering Handle ASM
1:2	109-8054	4	Bushing-Flange	14:1	109-5668	1	Grip-Control, Lever
2	116-0881	1	LH Motion Control And Bushing ASM	15	109-6590	1	LH Steering Handle ASM
2:2	109-8054	4	Bushing-Flange	15:1	109-5668	1	Grip-Control, Lever
3	116-0648	2	Screw-HH, Thread Locking ●	16	104-8301	4	Nut-Flange, NI
4	109-4581	2	Arm-Control, Pump	17	323-7	4	Screw-HH
5	9080046	2	Screw-HH ●	18	109-5575	2	Spring-Leaf
6	1-303435	2	Washer-Spring	19	109-8106	2	Front Pump Linkage ASM
7	116-0027	2	Damper-Control, Motion	19:2	3219-2	2	Nut-Hex
8	104-8300	8	Nut-Flange, NI	19:3	1-323245	2	Spring-Compression
9	3230-2	2	Bolt-CARR	19:4	1-633152	1	Balljoint-LH
10	109-5891	2	Hub-Threaded	19:5	1-543017	1	Balljoint-RH
11	325-12	2	Screw-HH	20	109-9505	4	Washer-Spring
12	116-0039	1	Lever-Control Motion, RH	21	3256-6	2	Washer-Flat
13	116-0040	1	Lever-Control Motion, LH	22	32128-56	2	Nut-HF
				23	3256-23	2	Washer-Flat
				24	3218-5	2	Nut-Jam
				25	115-1794	2	Screw-HHF

● Use Pro-Lock, Nut Type (P/N 1-840022, .5ml tube) on threads.

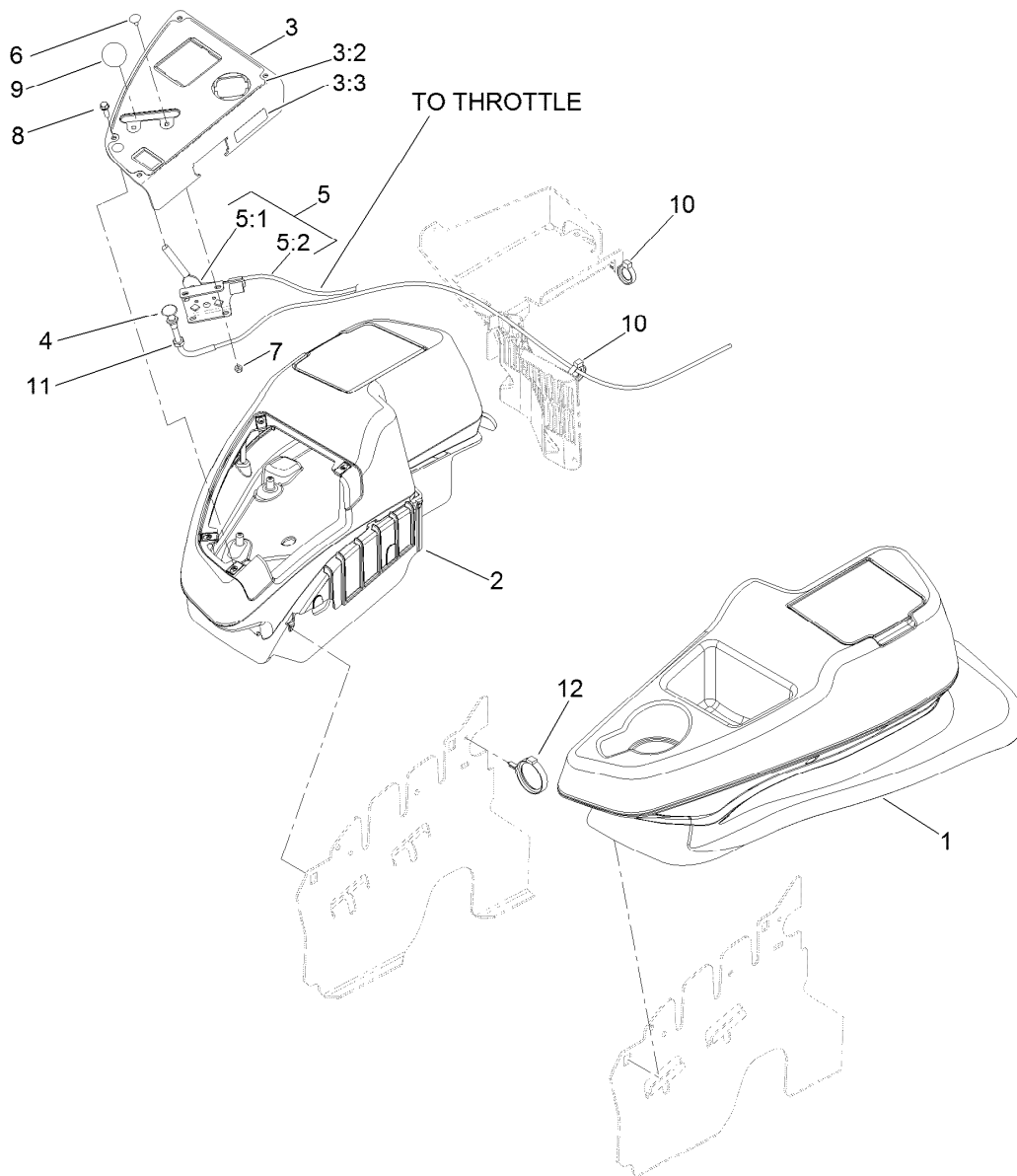

## Fender, Console and Control Assembly

Ref.	Part Number	Qty.	Description
1	115-7401	1	LH Wide Fender/Console ASM
2	115-7400	1	RH Wide Fender/Console ASM
3	114-9836	1	Control Panel ASM
3:2	120-5897	1	Decal-Control Panel
3:3	114-4466	1	Decal-Fuses
4	115-2756	1	Choke Control ASM
5	115-2752	1	Throttle Control ASM

Ref.	Part Number	Qty.	Description
5:1	112-2334	1	Lever-Throttle
5:2	115-3868	1	Cable-Throttle
6	1-807513	2	Bolt-CARR
7	3296-2	2	Nut-Lock, NI
8	32105-15	4	Screw
9	1-603175	1	Knob-Ball
10	105-1853	2	Clamp-Hose
11	3220-3	1	Nut-HJ
12	117-7817	1	Clamp-Harness

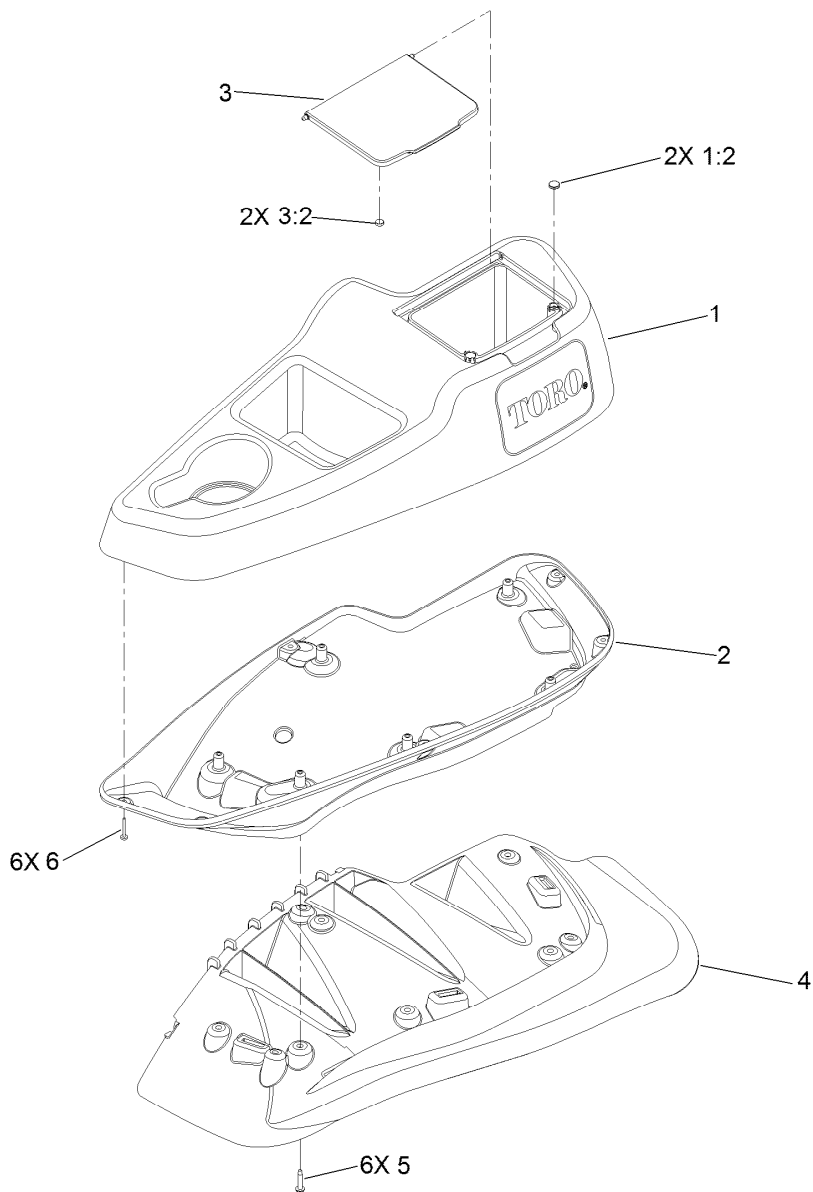

## LH Console Assembly No. 115-7401

<i>Ref.</i>	<i>Part Number</i>	<i>Qty.</i>	<i>Description</i>
1	114-1539	1	LH Wide Console Top ASM
1:2	117-0883	2	Puck
2	115-3641	1	Console-Lower, LH Wide
3	114-1537	1	Wide Lid ASM
3:2	114-5896	2	Magnet
4	109-9085	1	Fender-Wide, LH
5	32144-89	6	Screw-Thread Forming
6	117-0347	6	Screw-Fillister Head

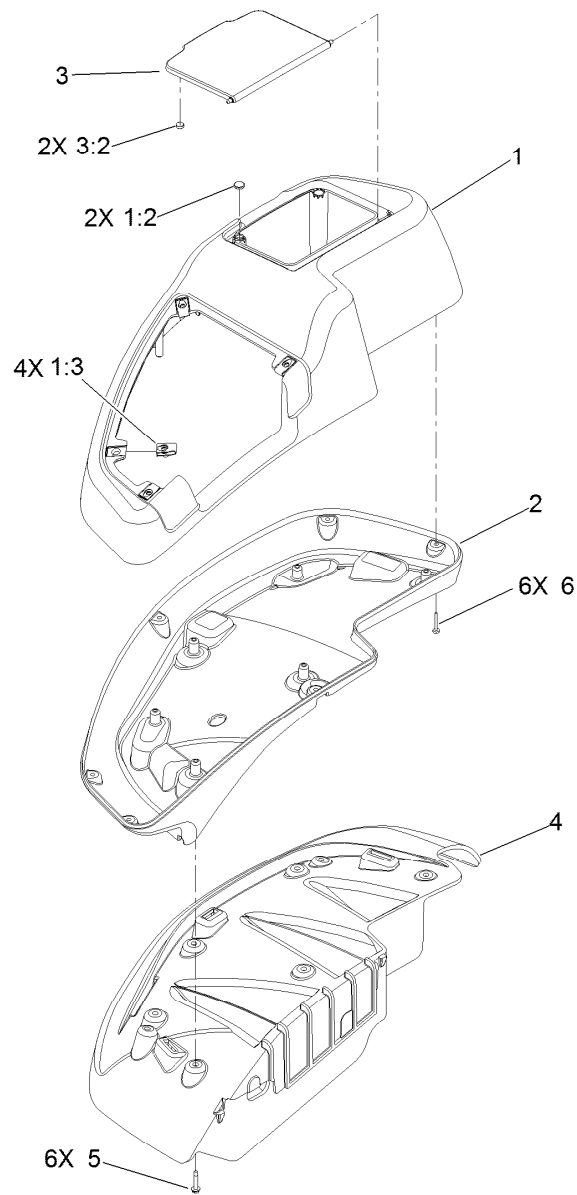

## RH Console Assembly No. 115-7400

<i>Ref.</i>	<i>Part Number</i>	<i>Qty.</i>	<i>Description</i>
1	114-1538	1	RH Wide Top Console ASM
1:2	117-0883	2	Puck
1:3	107069	4	Clip
2	115-3643	1	Console-Lower, RH Wide
3	114-1537	1	Wide Lid ASM
3:2	114-5896	2	Magnet
4	109-9083	1	Fender-Wide, RH
5	32144-89	6	Screw-Thread Forming
6	117-0347	6	Screw-Fillister Head

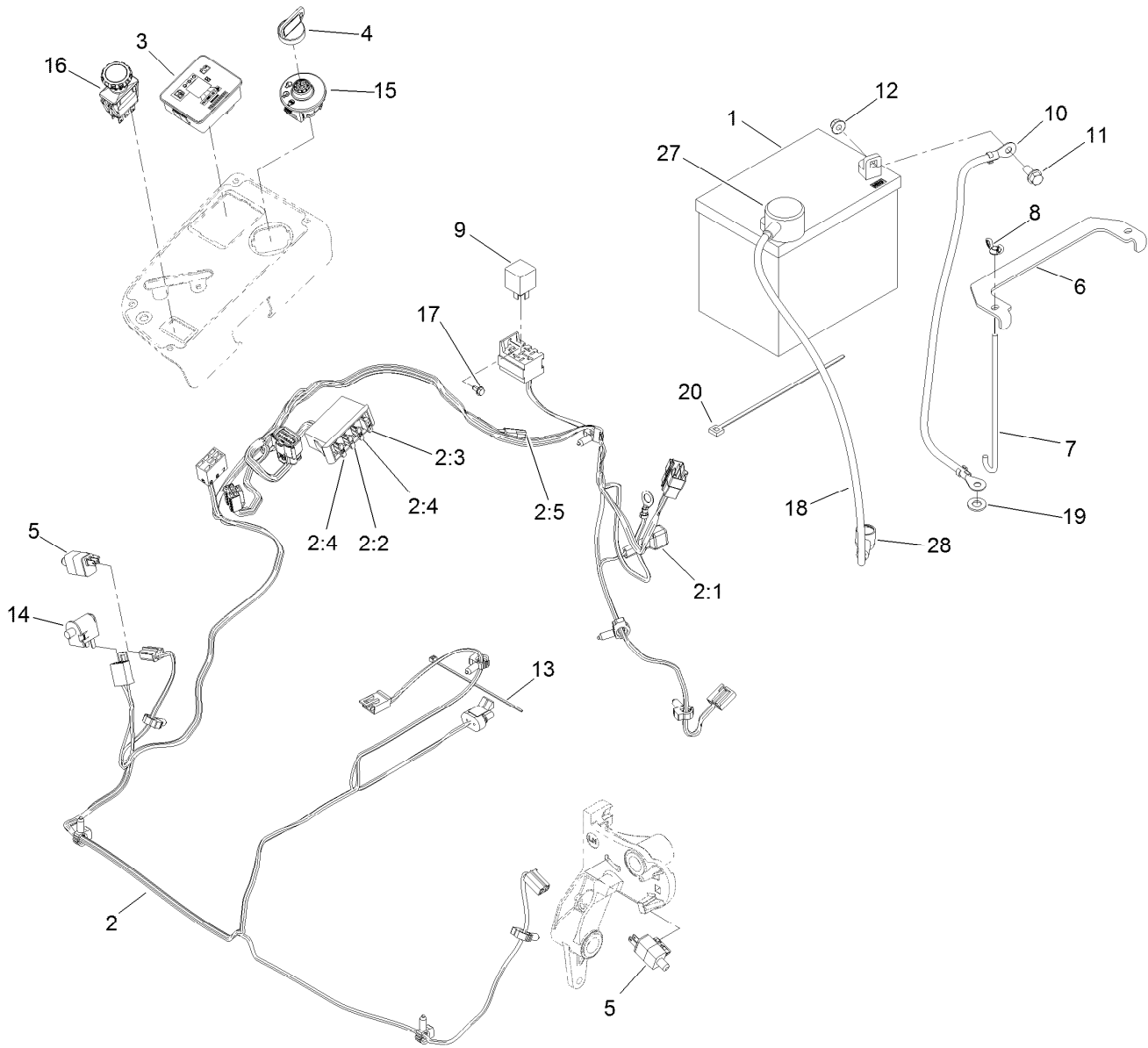

## Electrical Assembly

Ref.	Part Number	Qty.	Description	Ref.	Part Number	Qty.	Description
1	104-8162	1	Battery	10	114-1218	1	Cable-Battery, Negative
2	116-6009	1	Harness-Wire, Main ●	11	3234-5	2	Screw-HHF
2:1	103-3895	1	Diode-Tvs	12	104-8300	2	Nut-Flange, NI
2:2	218-578	1	Fuse-Blade, 10 Amp	13	1-303287	3	Tie-Cable
2:3	109355	1	Fuse-Blade, 15 Amp	14	82-2190	1	Switch-Bail
2:4	109102	2	Fuse-Blade, 25 Amp	15	117-2221	1	Switch-Ignition
2:5	116-0053	1	Cap-Plug	16	116-0124	1	Switch-PTO, 10A
3	117-3882	1	Fuel/Hour Meter ASM	17	104-2065	1	Screw-HWH
4	63-8360	1	Key-Ignition (W/Shield)	18	115-3864	1	Cable-Battery, Positive
5	110-6765	2	Switch-Single Pole No	19	3256-24	1	Washer-Flat
6	116-0042-03	1	Strap-Tie Down, Battery	20	1-303335	1	Tie-Plastic
7	1-633651	2	Bolt-Holddown	27	109-2407	1	Insulator-Battery
8	1-543792	2	Wingnut	28	1-543393	1	Insulator-Solenoid
9	1-643275	1	Relay				

● Use dielectric grease on all unsealed connectors and terminals only. Do not apply in sealed connectors.

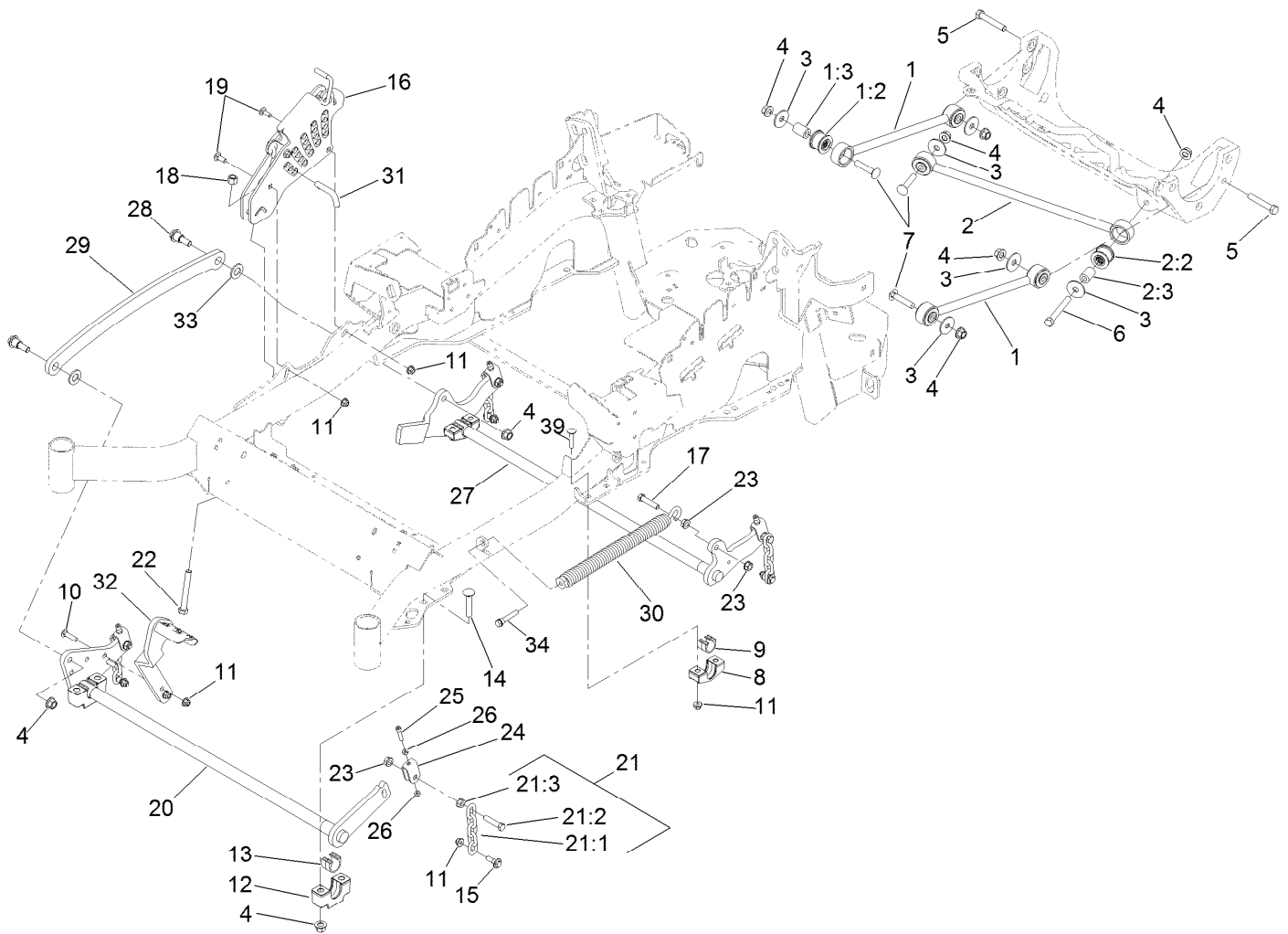

## Decklift Assembly

Ref.	Part Number	Qty.	Description	Ref.	Part Number	Qty.	Description
1	109-7952	2	Deck Strut ASM	14	116-1700	4	Bolt-CARR
1:2	109-5009	2	Bushing-Suspension, Rubber	15	109-9840	4	Screw-Shoulder, HHF
1:3	109-5010	2	Spacer	16	109-7438	1	HOC ASM
2	109-5013	1	Panhard Rod ASM	17	109-9065	1	Screw-HH
2:2	109-5009	2	Bushing-Suspension, Rubber	18	3296-23	1	Nut-Lock, NI
2:3	109-5010	2	Spacer	19	3231-2	2	Bolt-CARR
3	86-1990	6	Washer	20	116-2217-03	1	Front Cross Shaft ASM
4	99-5107	12	Nut-Lock	21	116-0756	4	Deck Lift Chain ASM
5	325-12	2	Screw-HH	21:1	1-633447	1	Chain-Lift, Deck
6	325-17	1	Screw-HH	21:2	109-9065	1	Screw-HH
7	3233-34	3	Screw-CARR	21:3	32128-37	1	Nut-HF
8	116-0818-03	2	Support-Cross Shaft, Rear Bearing	22	116-0559	1	Bolt-TAP
9	109-7173	2	Bearing-Cross Shaft, Rear	23	32128-37	6	Nut-HF
10	3231-4	2	Screw-CARR	24	109-9066	4	Yoke-Adjust, Deck
11	104-8301	12	Nut-Flange, NI	25	322-47	4	Screw-HH
12	109-9409	2	Support-Cross Shaft, Front Bearing	26	3218-2	8	Nut-Jam
13	109-9410	2	Bearing-Cross Shaft, Front	27	116-0459-03	1	Lift-Deck, Rear
				28	116-0780	2	Screw-HHF, Shoulder
				29	116-0797-03	1	Link-Lift, Deck
				30	116-0000	1	Extension Spring ASM
				31	116-5584	1	Pin-HOC

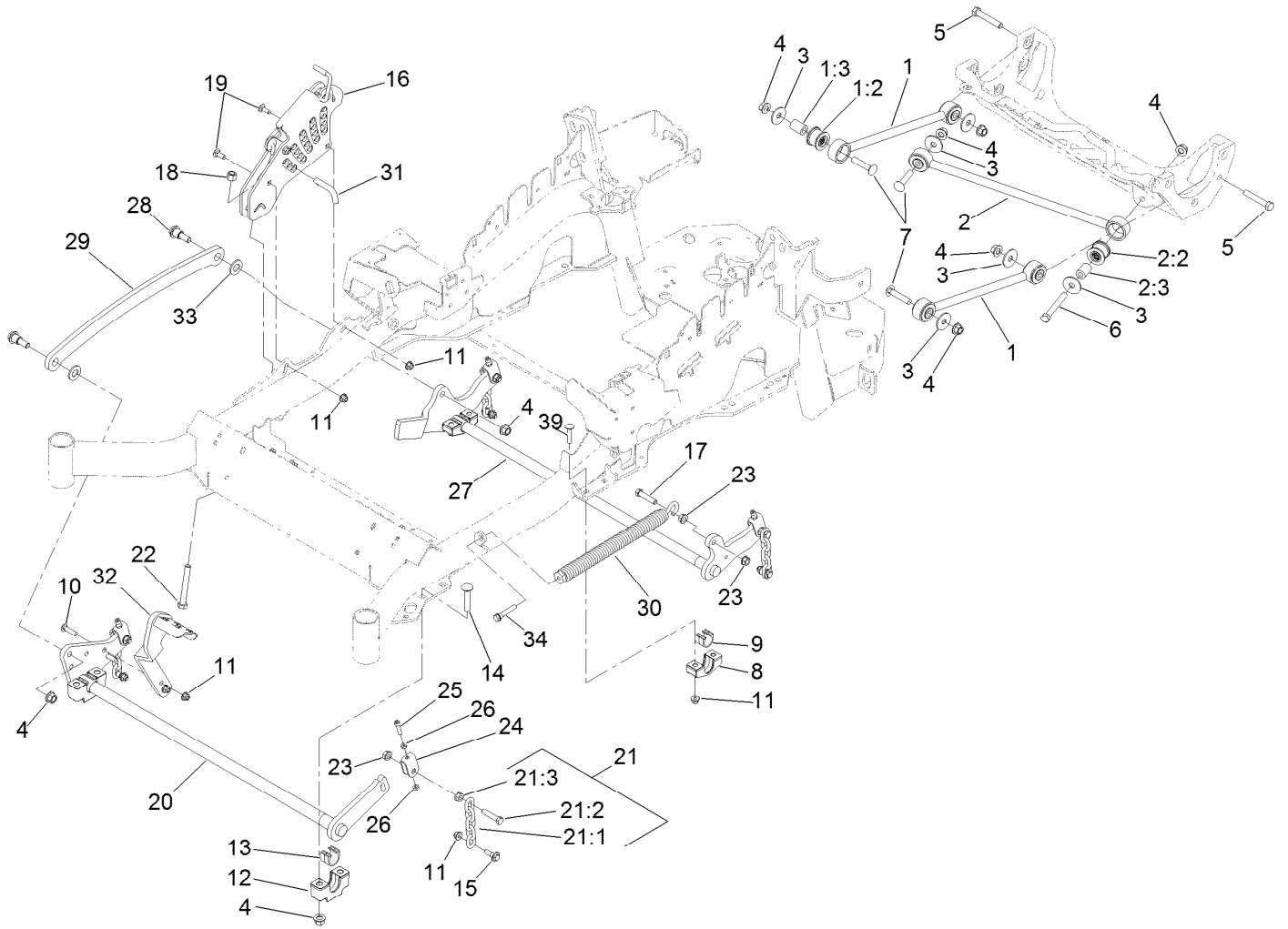

## Decklift Assembly (continued)

<i>Ref.</i>	<i>Part Number</i>	<i>Qty.</i>	<i>Description</i>	<i>Ref.</i>	<i>Part Number</i>	<i>Qty.</i>	<i>Description</i>
32	116-1919-01	1	Lever-Foot	34	92-7674	1	Bolt-Shoulder
33	3256-28	2	Washer-Flat	39	3231-5	4	Screw-CARR

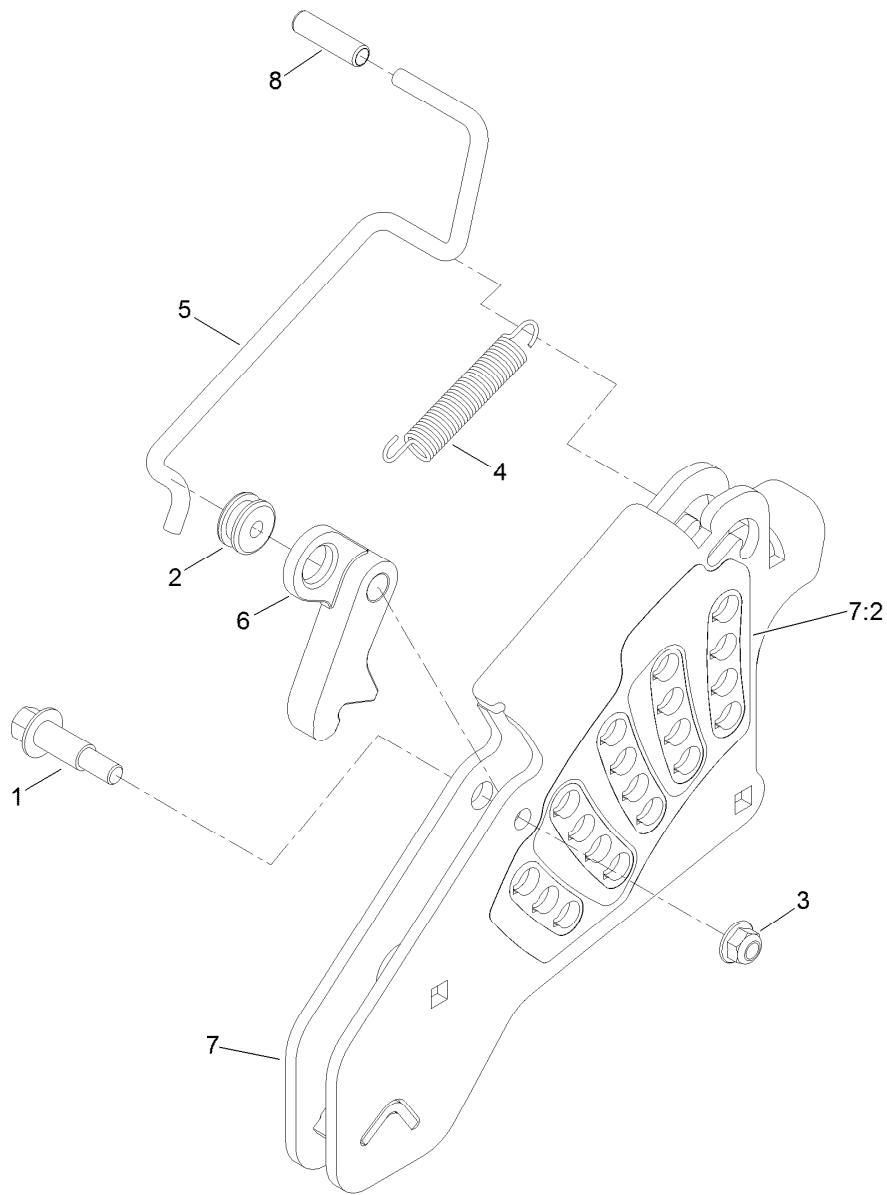

## Height-of-Cut Assembly No. 109-7438

<i>Ref.</i>	<i>Part Number</i>	<i>Qty.</i>	<i>Description</i>
1	62-1330	1	Bolt-Shoulder
2	109-7130	1	Grommet
3	104-8301	1	Nut-Flange, NI
4	109-7124	1	Spring-Extension
5	109-7128	1	Rod-Lock, Transport
6	116-0118	1	Pawl-Transport, HOC
7	109-7335	1	HOC Plate ASM
7:2	116-0752	1	Decal-HOC
8	109-8250	1	Grip-Lever

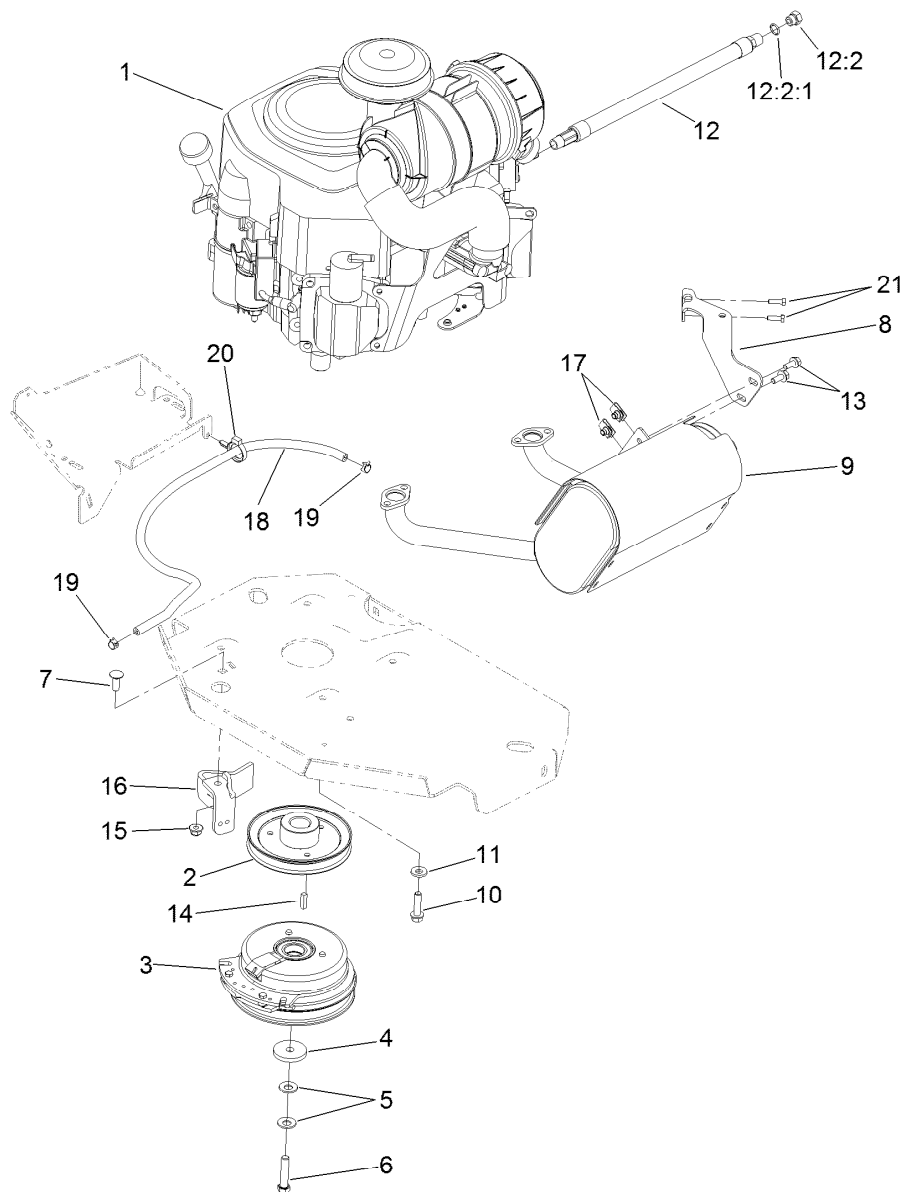

## Engine, Muffler and Clutch Assembly

Ref.	Part Number	Qty.	Description	Ref.	Part Number	Qty.	Description
1		1	Engine-Kohler, Ps-Cv740-3135 ●■	12	116-5316	1	Oil Drain Hose ASM
2	109-9905	1	Sheave	12:2	353-508	1	Plug-HH
3	116-1620	1	Clutch Kit	12:2:1	237-42	1	O-Ring
4	109-6919	1	Washer-Clutch	13	3234-5	3	Screw-HHF
5	1-603610	2	Washer-Spring	14	1-807259	1	Key
6	109-9762	1	Screw-HH W/Loctite ▲	15	104-8301	1	Nut-Flange, NI
7	3231-22	1	Screw-CARR	16	116-2612-01	1	Clutch-Anchor
8	116-4297	1	Muffler Bracket Kit	17	94-2413	3	U-Nut
9	116-1713	1	Muffler	18	109-0286	1	Hose-Fuel
10	32144-102	4	Screw-HWH	19	2412-98	2	Clamp-Hose
11	98-5975	4	Washer-Belleville	20	104-2490	1	Clamp-Hose
				21	116-4295	2	Screw-HH

● Not serviced separately

▲ Use Pro-Lock, Nut Type (P/N 1-840022, .5ml tube) on threads.

■ Obtain parts from [www.kohlerplus.com](http://www.kohlerplus.com)

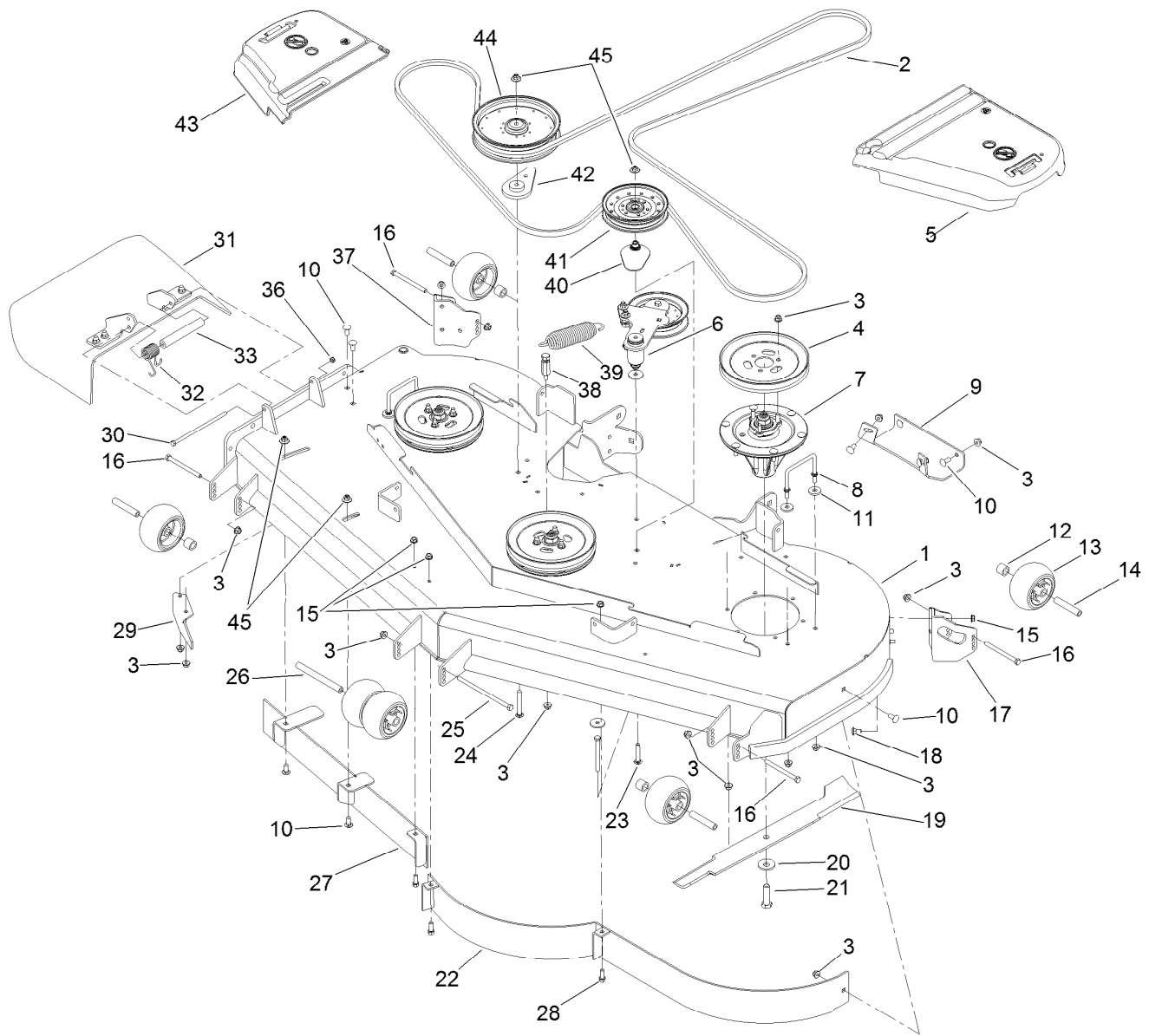

## Deck Assembly

Ref.	Part Number	Qty.	Description	Ref.	Part Number	Qty.	Description
1	114-5820	1	Deck ASM	19	105-7784-03	3	Blade-Hi Flow, 24.5 Inch
2	114-5859	1	Belt-V	20	103-0865	3	Washer-Blade Bolt, Heavy
3	104-8301	44	Nut-Flange, NI	21	51-4060	3	Screw-Blade
4	105-7733	3	Pulley	22	114-5843-01	1	Baffle ASM
5	109-6938	1	Cover-Belt, LH	23	3231-40	1	Bolt-CARR, Short Neck
6		1	Idler Arm ASM ●	24	3231-42	1	Screw-CARR
7	119-8560	3	Spindle ASM	25	108-5388	1	Screw-HH
8	109-6982	2	Wireform-Cover	26	98-5967	1	Spacer-Wheel
9	112-4230-01	1	Plate-Skid	27	115-7465-01	1	Baffle ASM
10	3231-27	9	Screw-CARR	28	92-1624	3	Screw-HWH
11	1-373034	4	Washer	29	106-3216-01	1	Baffle-Discharge
12	98-7913	4	Tube-Spacer	30	322-50	1	Screw-HH
13	1-603299	6	Roller-Scalp, Anti	31	108-2792	1	Rubber Deflector ASM
14	98-7912	4	Tube-Spacer	32	108-4052	1	Spring-Torsion
15	3290-357	9	Nut-HHF, Whiz	33	105-4622	1	Spacer
16	323-23	4	Screw-HH	36	3296-47	1	Nut-Lock, NI
17	106-7354-01	1	Mount-Wheel, LH	37	106-7355-01	1	Mount-Wheel, RH
18	3231-1	6	Screw-CARR	38	114-5867	1	Anchor-Spring, Tall

● Not serviced separately

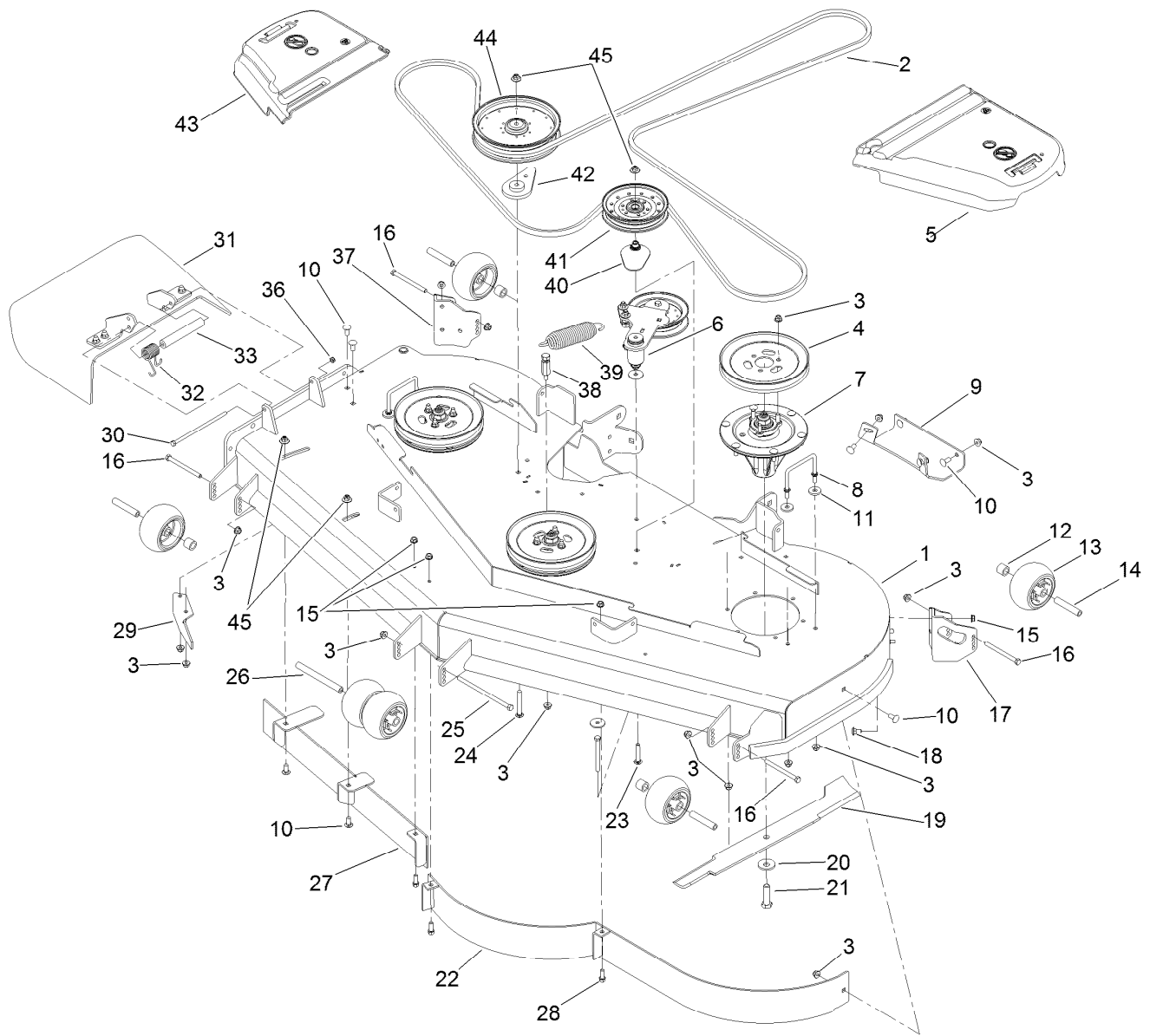

## Deck Assembly (continued)

<i>Ref.</i>	<i>Part Number</i>	<i>Qty.</i>	<i>Description</i>	<i>Ref.</i>	<i>Part Number</i>	<i>Qty.</i>	<i>Description</i>
39	116-6317	1	Spring-Extension	43	116-0094	1	Cover-Belt, RH
40	109-2872	1	Spacer-Pulley	44	109-8590	1	Pulley-Idler
41	116-4670	1	Pulley-Idler, Flat	45	109-6658	4	Nut-Flange, NI
42	109-9416	1	Spacer-Idler				

● Not serviced separately

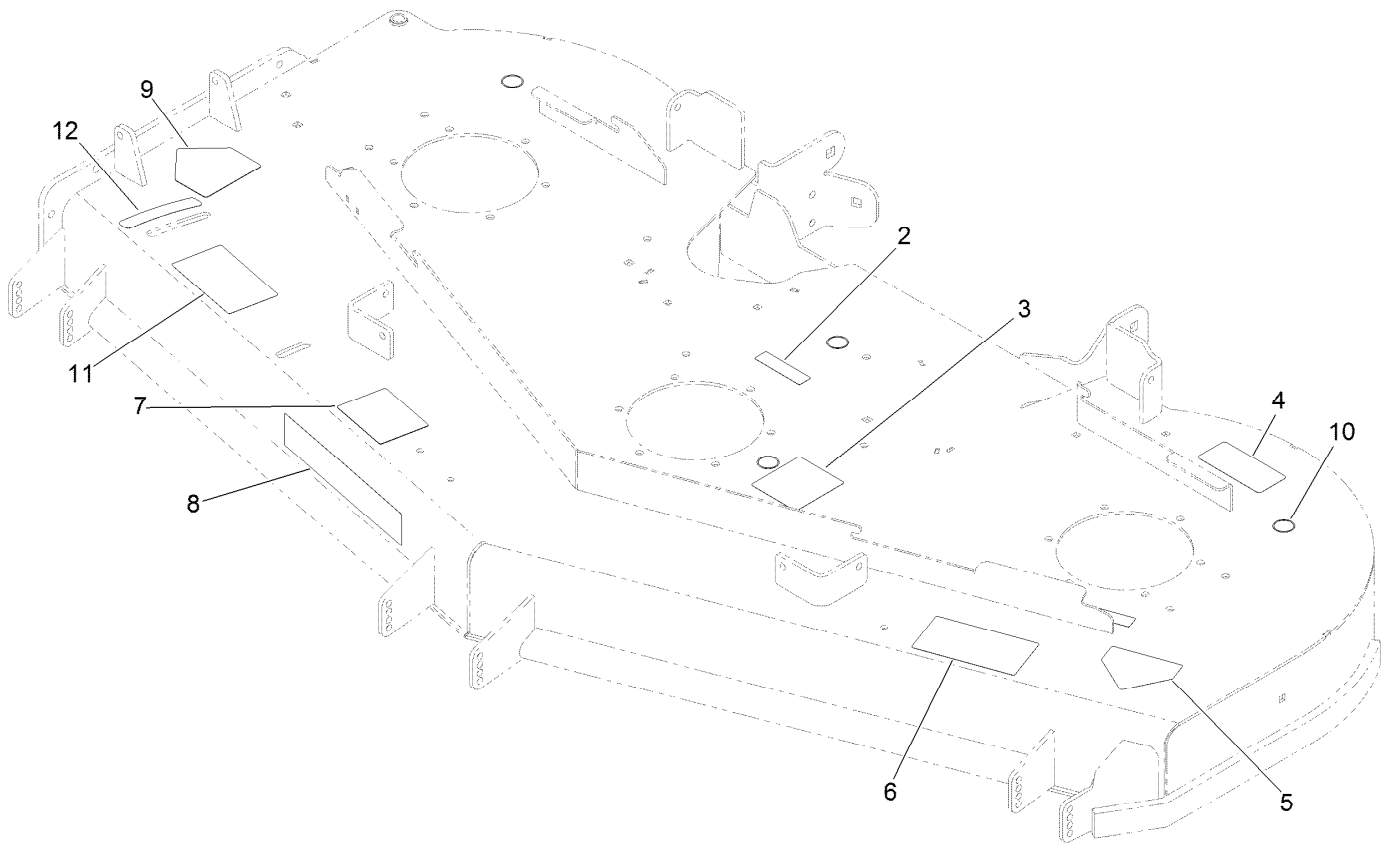

## Deck Decal Assembly No. 114-5820

<i>Ref.</i>	<i>Part Number</i>	<i>Qty.</i>	<i>Description</i>
2	98-5954	3	Decal-Cover, Missing
3	115-7445	1	Decal-Routing, Deck Belt
4	68-8340	1	Decal-Torque
5	1-403005	1	Decal-Danger
6	66-1340	1	Decal-Danger, Thrown Object
7	105-7798	1	Decal-Scalp, Anti
8	107-1620	1	Decal
9	54-9220	1	Decal-Danger
10	58-6520	4	Decal-Grease
11	110-2068	1	Decal-Adjustment, Baffle
12	110-2067	1	Decal-Setting, Baffle

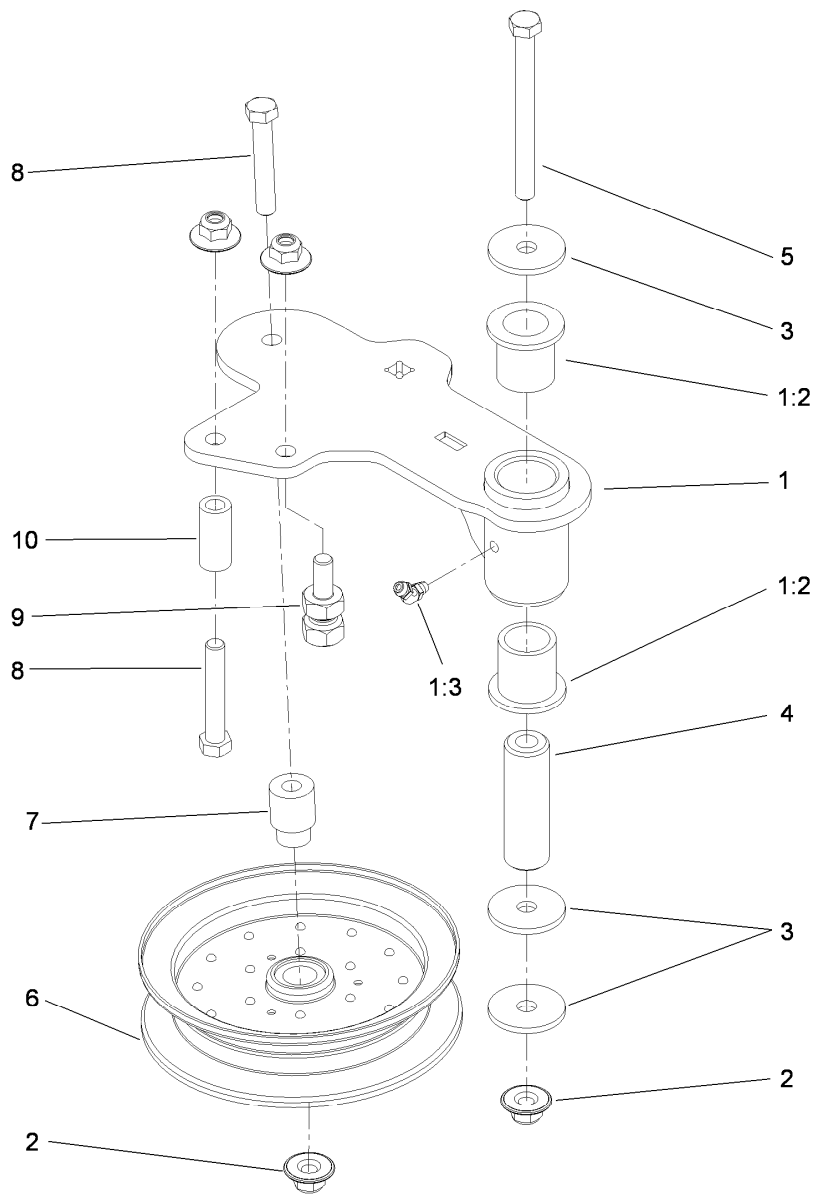

## Idler Assembly

Ref.	Part Number	Qty.	Description
1	114-5870	1	Idler Arm ASM
1:2	1-303514	2	Bearing-Flanged
1:3	1481	1	Fitting-Grease
2	109-6658	4	Nut-Flange, NI
3	1-213069	3	Washer
4	114-5848	1	Spacer-Plain
5	98-5961	1	Screw-HH
6	116-4668	1	Idler-Pulley, Flanged
7	112-4212	1	Mount-Pulley
8	323-11	2	Screw-HH
9	114-5866	1	Anchor-Spring, Short
10	104-0151	1	Spacer

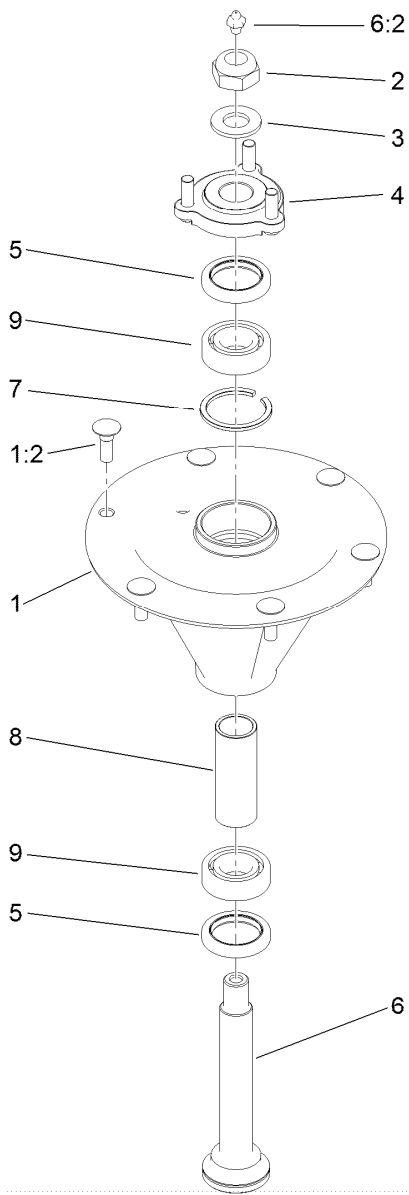

## Spindle Assembly No. 119-8560

Ref.	Part Number	Qty.	Description
1		1	Spindle Housing And Studs ASM ●
1:2	114-8195	6	Bolt-Ribbed Neck
2	3296-67	1	Nut-Lock, NI
3	92-5836	1	Washer
4	117-6172	1	Spindle Hub ASM
5	253-133	2	Seal-Oil
6	119-8527	1	Spindle Shaft And Zerk ASM
6:2	302-2	1	Fitting-Grease
7	119-8532	1	Snap Ring
8	117-6184	1	Spacer
9	119-8558	2	Bearing-Noseal

● Not serviced separately

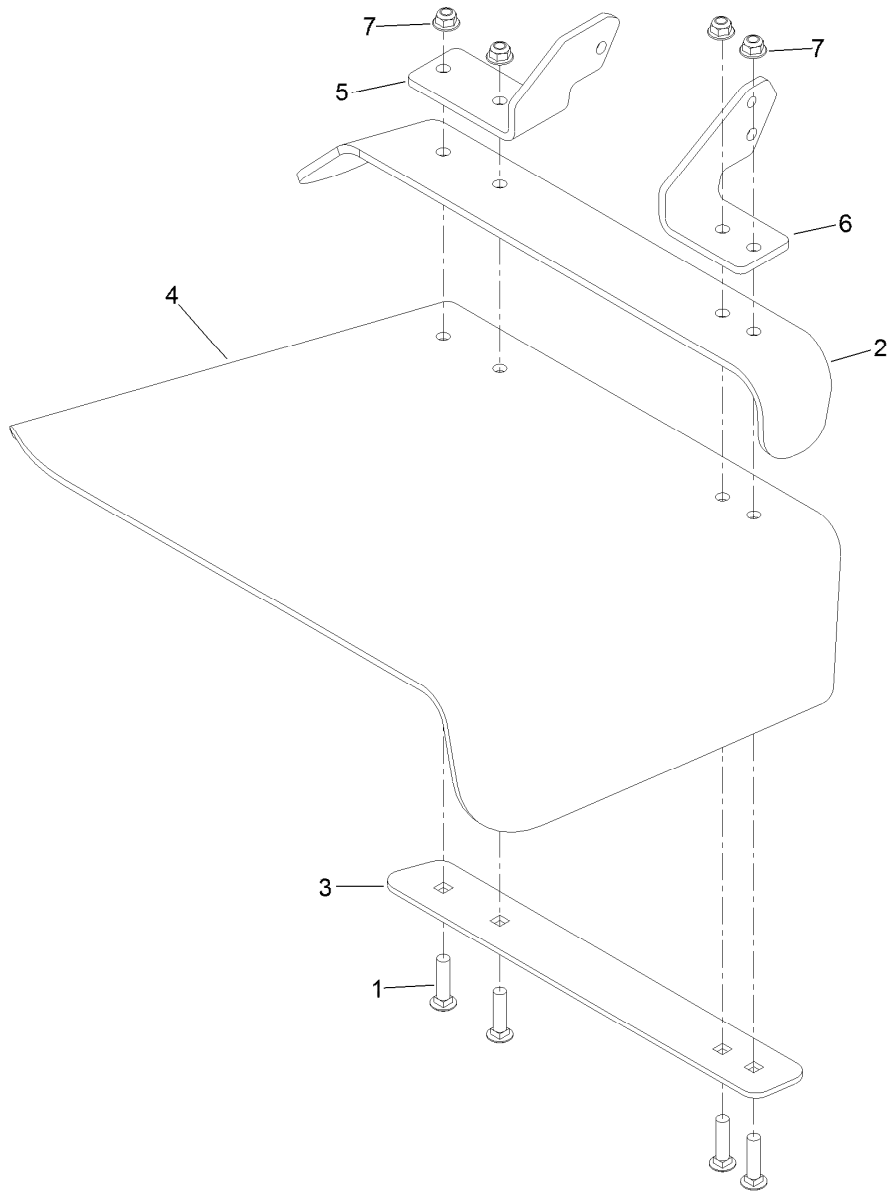

## Rubber Deflector Assembly No. 108-2792

<i>Ref.</i>	<i>Part Number</i>	<i>Qty.</i>	<i>Description</i>
1	3231-4	4	Screw-CARR
2	106-3246-01	1	Deflector
3	106-3248-03	1	Strap-Discharge
4	108-5029	1	Deflector-Rubber
5	108-4059-01	1	Plate-Hinge, Rear
6	106-3253-01	1	Plate-Hinge, Front
7	104-8301	4	Nut-Flange, NI

# Attachments and Accessories

## For 74916 Z Master Professional 5000 Series Riding Mower with 72in TURBO FORCE Side Discharge Mower

<b>Product Name</b>	<b>Model/Part</b>
Blade-Mid Flow, 24.5in .....	105-7711-03
Blade-Lo Flow, 24.5in .....	105-7712-03
Blade-Atomic, 24.5in .....	105-7719-03
Blade-Recycler, 24.5in .....	105-7778-03
Blade-Hi Flow, 24.5in.....	105-7784-03
6 Pack Blade, 24.5in Hi-Flow .....	108-1120
6 Pack Blade, 24.5in Atomic .....	108-1126
Anti-Scalp Kit (Trim Side).....	108-4140
Hitch Kit .....	109-9487
6 Pack-Blade, 24.5in Mid-Flow .....	110-0404
6 Pack-Blade, 24.5in Lo-Flow .....	110-0410
6 Pack-Blade, 24.5in Recycler.....	110-0411
Hypr-Oil 500 (quart).....	114-4713
Hypr-Oil 500 (gallon).....	114-4714
Hypr-Oil 500-5 (5 gallon).....	114-4715
Bimini Folding Shade Assembly .....	115-4510
Recycler Kit .....	115-7469
Roller Striper Kit.....	115-7480
Light Kit.....	116-1154
Z Stand Kit.....	117-0354
Operator-Controlled Discharge Chute Kit .....	117-3600
Deluxe Suspension Seat Kit .....	117-6174
Toro Deluxe Rider Cover.....	490-7319
Spark Arrestor Screen .....	75-6880
Blower and Drive Kit .....	78554
E-Z Vac Triple Bagging System .....	78564
E-Z Vac DFS Collection System .....	78568
Filter Minder Gauge .....	99-4664
Trash Holder Kit.....	TC26

**Notes:**

**Notes:**



**Count on it.**