



Count on it.

Operator's Manual

TITAN MX4880, MX5480, and MX6080 Zero-Turn-Radius Riding Mower

Model No. 74871—Serial No. 313000001 and Up

Model No. 74872—Serial No. 313000001 and Up

Model No. 74873—Serial No. 313000001 and Up



g020432



This machine is a ride-on, rotary-blade lawnmower intended to be used by homeowners in residential applications. It is primarily designed for cutting grass on well-maintained lawns. It is not designed for cutting brush, mowing grass and other growth alongside highways, or for agricultural uses.

▲ WARNING

CALIFORNIA Proposition 65 Warning

This product contains a chemical or chemicals known to the State of California to cause cancer, birth defects, or reproductive harm.

The engine exhaust from this product contains chemicals known to the State of California to cause cancer, birth defects, or other reproductive harm.

Important: This engine is not equipped with a spark arrester muffler. It is a violation of California Public Resource Code Section 4442 to use or operate the engine on any forest-covered, brush-covered, or grass-covered land. Other states or federal areas may have similar laws.

This spark ignition system complies with Canadian ICES-002

▲ WARNING

Removing standard original equipment parts and accessories may alter the warranty, traction, and safety of the machine. Failure to use original Toro parts could cause serious injury or death. Making unauthorized changes to the engine, fuel or venting system, may violate EPA and CARB regulations.

Replace all parts including, but not limited to, tires, belts, blades, and fuel system components with original Toro parts.

The enclosed *Engine Owner's Manual* is supplied for information regarding the US Environmental Protection Agency (EPA) and the California Emission Control Regulation of emission systems, maintenance, and warranty. Replacements may be ordered through the engine manufacturer.

For models with stated engine horsepower, the gross horsepower of the engine was laboratory tested by the engine manufacturer in accordance with SAE J1995 and rated to J2723.

Introduction

Read this information carefully to learn how to operate and maintain your product properly and to avoid injury and product damage. You are responsible for operating the product properly and safely.

You may contact Toro directly at www.Toro.com for product and accessory information, help finding a dealer, or to register your product.

Whenever you need service, genuine Toro parts, or additional information, contact an Authorized Service Dealer or Toro Customer Service and have the model and serial numbers of your product ready. **Figure 1** identifies the location of the model and serial numbers on the product. Write the numbers in the space provided.

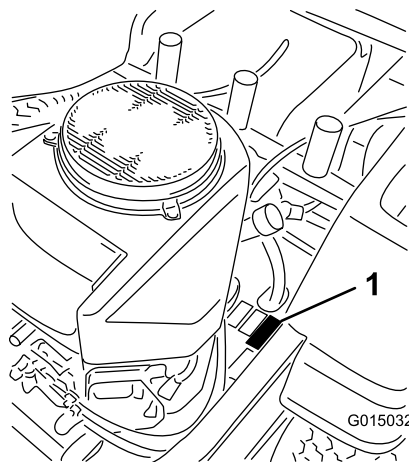

Figure 1

1. Model and serial number location

Model No. _____

Serial No. _____

This manual identifies potential hazards and has safety messages identified by the safety alert symbol (Figure 2), which signals a hazard that may cause serious injury or death if you do not follow the recommended precautions.



Figure 2

1. Safety alert symbol

This manual uses 2 other words to highlight information.

Important calls attention to special mechanical information and **Note** emphasizes general information worthy of special attention.

Contents

Safety	4
Safe Operating Practices	4
Toro Riding Mower Safety	6
Slope Indicator	7
Safety and Instructional Decals	8
Setup	14
1 Connecting the Battery	14
2 Checking the Mower Adjustment	14
3 Completing the Setup	15
Product Overview	16
Controls	17
Operation	18
Think Safety First	18
Using the Rollover Protection System (ROPS)	18
Adding Fuel.....	19
Checking the Engine Oil Level	20
Operating the Parking Brake	20
Operating the Throttle.....	21
Operating the Choke.....	21
Operating the Ignition Switch	21
Starting and Stopping the Engine.....	22
Operating the Mower Blade Control Switch (PTO)	23
The Safety Interlock System	23
Driving Forward or Backward	24
Stopping the Machine	25
Adjusting the Height of Cut	25
Adjusting the Anti-Scalp Rollers	27
Positioning the Seat	27
Adjusting the Motion Control Levers	27
Pushing the Machine by Hand	28
Using the Side Discharge	29
Operating Tips	30
Maintenance	31
Recommended Maintenance Schedule(s)	31
Premaintenance Procedures	33
Raising the Seat.....	33
Lubrication	33
Greasing the Bearings	33
Engine Maintenance	34
Servicing the Air Cleaner	34
Servicing the Engine Oil.....	34
Servicing the Spark Plug.....	36
Cleaning the Cooling System.....	37
Fuel System Maintenance	38
Replacing the Fuel Filter.....	38
Electrical System Maintenance	39
Servicing the Battery.....	39
Servicing the Fuses	40
Drive System Maintenance	41
Checking the Tire Pressure	41
Hydraulic System Maintenance	41
Checking the Hydraulic Oil Level.....	41
Changing the Hydraulic System Filter and Oil.....	41
Mower Deck Maintenance.....	43

Safety

This machine meets or exceeds the B71.1-2012 specifications of the American National Standards Institute, in effect at the time of production. However, improper use or maintenance by the operator or owner can result in injury. To reduce the potential for injury, comply with these safety instructions and always pay attention to the safety alert symbol, which means CAUTION, WARNING, or DANGER-"personal safety instruction." Failure to comply with the instruction may result in personal injury or death.

Safe Operating Practices

This product is capable of amputating hands and feet and throwing objects. Always follow all safety instructions to avoid serious injury or death.

The following instructions are from ANSI standard B71.1-2012. All the language within this ANSI standard applies to this machine; however, due to the application of the standard across many different types of products some statements can seem general or misleading. In these instances, Toro has refined the statement to convey the meaning of the standard while better matching the product this *Operator's Manual* pertains. Safety information in addition to the instructions found in the ANSI standard below can be found in Toro Riding Mower Safety at the end of this section.

General Operation

- Read, understand, and follow all instructions in the operator's manual and on the machine before starting.
- Do not put hands or feet near rotating parts or under the machine. Keep clear of the discharge opening at all times.
- Allow only responsible adults who are familiar with the instructions to operate this machine.
- Clear the area of objects such as rocks, toys, wire, etc., which could be picked up and thrown by the blade.
- Be sure the area is clear of other people before mowing. Stop the machine if anyone enters the area.
- Never carry passengers.
- Do not mow in reverse unless absolutely necessary. Always look down and behind before and while backing up.
- Never direct discharged material toward anyone.
- Do not operate the machine without deflector, discharge cover or entire grass collection system in place and working.
- Be alert, slow down and use caution when making turns. Look behind and to the side before changing directions.
- Never leave a running machine unattended. Always turn off blades, set parking brake, stop engine, and remove key before dismounting.

Servicing the Cutting Blades.....	43
Mower Deck Leveling.....	46
Inspecting the Belts.....	47
Replacing the Mower Belt.....	47
Removing the Mower.....	49
Installing the Mower.....	50
Replacing the Grass Deflector.....	50
Cleaning.....	51
Washing the Underside of the Mower.....	51
Waste Disposal.....	52
Storage.....	52
Cleaning and Storage.....	52
Troubleshooting.....	54
Schematics.....	56

- Disengage blades when not mowing. Stop the engine, wait for all parts to come to a complete stop and remove the key before cleaning the machine, removing the grass catcher or unclogging the discharge chute.
- Operate the machine only in daylight or good artificial light.
- Do not operate the machine while under the influence of alcohol or drugs.
- Watch for traffic when operating near or crossing roadways.
- Use extra care when loading or unloading the machine into a trailer or truck.
- Always wear eye protection when operating the machine.
- Data indicates that operators, age 60 years and above, are involved in a large percentage of riding mower-related injuries. These operators should evaluate their ability to operate the riding mower safely enough to protect themselves and others from serious injury.
- Always follow the recommendations for use of wheel weights or counterweights.
- Lightning can cause severe injury or death. If lightning is seen or thunder is heard in the area, do not operate the machine; seek shelter.

Slope Operation

Slopes are a major factor related to loss of control and tip-over accidents, which can result in severe injury or death. Operation on all slopes requires extra caution. If you cannot back up the slope or if you feel uneasy on it, do not mow it.

- Do not mow slopes greater than 15 degrees.
- Watch for holes, ruts, bumps, rocks, or other hidden objects. Uneven terrain could overturn the machine. Tall grass can hide obstacles.
- Choose a low ground speed so you will not have to stop while operating on a slope.
- Do not mow slopes when grass is wet. Slippery conditions reduce traction and could cause sliding and loss of control.
- Avoid starting, stopping, or turning on a slope. If the tires lose traction, disengage the blade(s) and proceed slowly straight down the slope.
- Always keep the drive wheels engaged when going down slopes. Do not shift to neutral and coast downhill.
- Keep all movement on slopes slow and gradual. Do not make sudden changes in speed or direction, which could cause the machine to roll over.
- Remove or mark obstacles such as rocks, tree limbs, etc. from the mowing area. Tall grass can hide obstacles.
- Avoid sudden starts when mowing uphill because the mower may tip backwards.
- Be aware that loss of traction may occur going downhill. Weight transfer to the front wheels may cause drive wheels to slip and cause loss of braking and steering.

- Use extra care while operating machine with grass catchers or other attachments; they can affect the stability of the machine. Do not use on steep slopes.
- Do not try to stabilize the machine by putting your foot on the ground.
- Do not mow near drop-offs, ditches, embankments, or water. The machine could suddenly roll over if a wheel goes over the edge or if the edge caves in.
- Use a walk behind mower and/or a hand trimmer near drop-offs, ditches, steep banks or water.

Using the Rollover Protection System (ROPS)

- Keep the roll bar in the raised and locked position and use the seat belt when operating the machine.
- Be certain that the seat belt can be released quickly in the event of an emergency.
- Be aware there is no rollover protection when the roll bar is down.
- Check the area to be mowed and never fold the ROPS in areas where there are slopes, drop offs or water.
- Lower the rollbar only when absolutely necessary. Do not wear the seat belt with the roll bar folded down.
- Check carefully for overhead clearances (i.e. branches, doorways, electrical wires) before driving under any objects and do not contact them.

Children

Tragic accidents can occur if the operator is not alert to the presence of children. Children are often attracted to the machine and the mowing activity. Never assume that children will remain where you last saw them.

- Keep children out of the mowing area and in the watchful care of a responsible adult other than the operator.
- Be alert and turn the machine off if children enter the area.
- Before and while backing or changing direction, look behind, down, and side-to-side for small children.
- Never carry children, even with the blades off. They may fall off and be seriously injured or interfere with safe machine operation.
- Children who have been given rides in the past may suddenly appear in the mowing area for another ride and be run over or backed over by the machine.
- Never allow children to operate the machine.
- Use extreme care when approaching blind corners, end of a fence, shrubs, trees, or other objects that may block your view of a child.

Towing

A hitch kit is available for this machine and can be obtained by contacting an Authorized Toro Dealer. Do not tow

without first installing this manufacturer approved hitch. The following guidelines apply when towing with the approved hitch kit installed.

- Tow only with a machine that has a hitch designed for towing. Do not attach towed equipment except at the hitch point.
- Follow the manufacturer's recommendation for weight limits for towed equipment and towing on slopes.
- Never allow children or others in or on towed equipment.
- On slopes, the weight of the towed equipment may cause loss of traction and loss of control.
- Travel slowly and allow extra distance to stop.

Service

Safe Handling of Fuel:

To avoid personal injury or property damage, use extreme care in handling gasoline. Gasoline is extremely flammable and the vapors are explosive.

- Extinguish all cigarettes, cigars, pipes and other sources of ignition.
- Use only an approved fuel container.
- Never remove the fuel cap or add fuel when the engine is running.
- Allow the engine to cool before refueling.
- Never refuel the machine indoors.
- Never store the machine or fuel container where there is an open flame, spark, or pilot light such as on a water heater or other appliances.
- Never fill containers inside a vehicle or on a truck or trailer with a plastic liner. Always place containers on the ground away from your vehicle before filling.
- Remove gas-powered equipment from the truck or trailer and refuel it on the ground. If this is not possible, then refuel such equipment with a portable container, rather than from a gasoline dispenser nozzle.
- Keep the nozzle in contact with the rim of the fuel tank or container opening at all times until the fueling is complete. Do not use a nozzle lock-open device.
- If fuel is spilled on clothing, change clothing immediately.
- Never overfill the fuel tank. Replace gas cap and tighten securely.

General Service:

- Never operate a machine inside a closed area. Engine exhaust contains carbon monoxide, which is an odorless, deadly poison that can kill you.
- Keep all nuts and bolts tight, especially the blade attachment bolts, and to be sure the equipment is in safe working condition.

- Never interfere with the intended function of a safety device or reduce the protection provided by a safety device. Check their proper operation regularly.
- Keep machine free of grass, leaves, or other debris build up. Clean up oil or fuel spillage and remove any fuel soaked debris. Allow machine to cool before storing.
- If you strike a foreign object, stop and inspect the machine. Repair, if necessary, before restarting.
- Never make any adjustments or repairs with the engine running.
- Check grass catcher components and the discharge guard frequently and replace with manufacturer's recommended parts, when necessary.
- Mower blades are sharp. Wrap the blade or wear gloves, and use extra caution when servicing them.
- Check for proper brake operation frequently. Adjust and service as required.
- Maintain or replace safety and instruction labels as necessary.
- Use only genuine Toro replacement parts to ensure that original standards are maintained.

Toro Riding Mower Safety

The following list contains safety information specific to Toro products or other safety information that you must know that may not be included in the ANSI standards.

- Stop the engine, move the motion control levers to neutral and outward to the park position, disengage the blade control switch, remove key before and disconnect spark plug wire(s) performing any service, repairs, maintenance or adjustments.
- Keep hands, feet, hair, and loose clothing away from attachment discharge area, underside of mower and any moving parts while engine is running.
- Do not touch equipment or attachment parts which may be hot from operation. Allow to cool before attempting to maintain, adjust or service.
- Battery acid is poisonous and can cause burns. Avoid contact with skin, eyes, and clothing. Protect your face, eyes, and clothing when working with a battery.
- Battery gases can explode. Keep cigarettes, sparks and flames away from battery.
- Use only Toro approved attachments. Warranty may be voided if used with unapproved attachments.
- If loading the machine onto a trailer or truck, use a single, full-width ramp only. The ramp angle should not exceed 15 degrees.

Slope Indicator

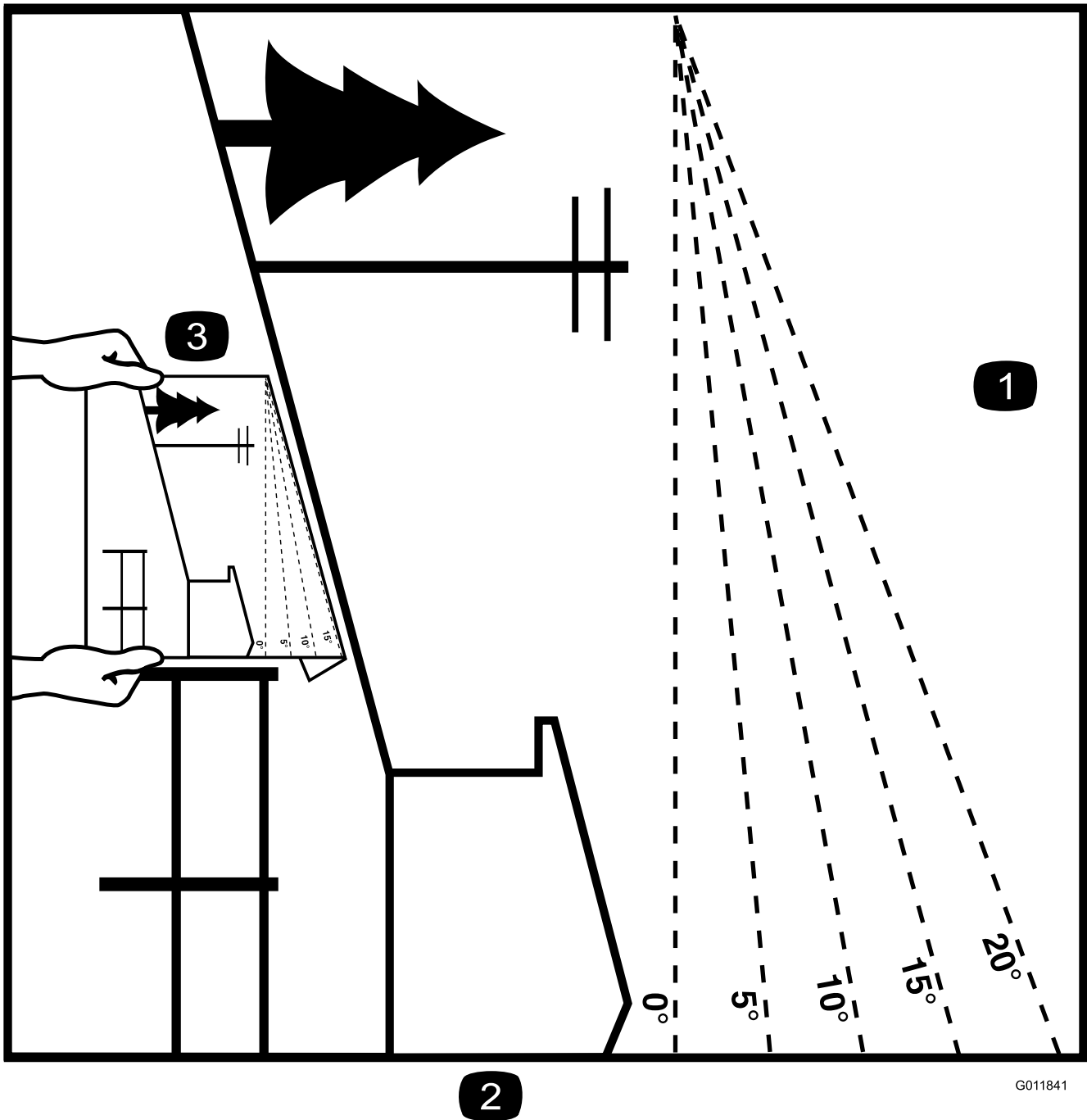

G011841

2

Figure 3

This page may be copied for personal use.

1. The maximum slope you can safely operate the machine on is **15 degrees**. Use the slope chart to determine the degree of slope of hills before operating. **Do not operate this machine on a slope greater than 15 degrees**. Fold along the appropriate line to match the recommended slope.
2. Align this edge with a vertical surface, a tree, building, fence pole, etc.
3. Example of how to compare slope with folded edge.

Safety and Instructional Decals



Safety decals and instructions are easily visible to the operator and are located near any area of potential danger. Replace any decal that is damaged or lost.



93-7009

1. Warning—don't operate the mower with the deflector up or removed; keep the deflector in place.
2. Cutting/dismemberment hazard of hand or foot, mower blade—stay away from moving parts.

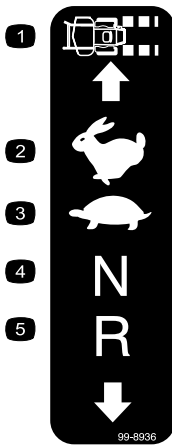

99-8936

- | | |
|------------------|------------|
| 1. Machine speed | 4. Neutral |
| 2. Fast | 5. Reverse |
| 3. Slow | |

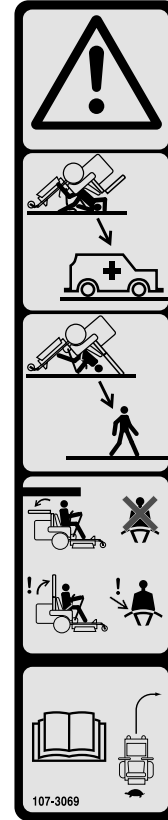

107-3069

1. Warning—there is no rollover protection when the roll bar is down.
2. To avoid injury or death from a rollover accident, keep the roll bar in the fully raised and locked position and wear the seat belt. Lower the roll bar only when absolutely necessary; do not wear the seat belt when the roll bar is down.
3. Read the Operator's manual; drive slowly and carefully.



Manufacturer's Mark

1. Indicates the blade is identified as a part from the original machine manufacturer.



110-6691

1. Thrown object hazard—keep bystanders a safe distance from the machine.
2. Thrown object hazard, mower—do not operate without the deflector, discharge cover, or grass collection system in place.
3. Cutting/dismemberment of hand or foot—stay away from moving parts.

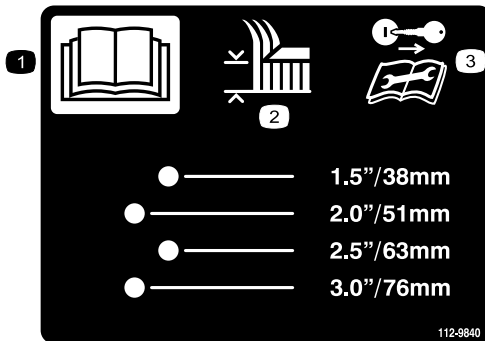

112-9840

1. Read the *Operator's Manual*.
2. Height of cut
3. Remove the ignition key and read the instructions before servicing or performing maintenance.

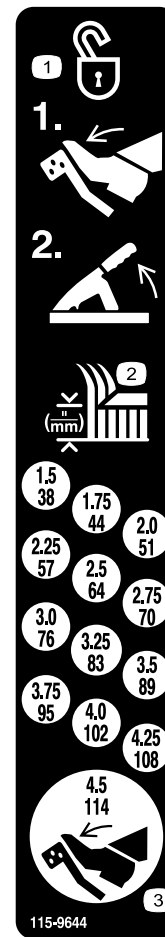

115-9644

1. Press the pedal and lift the height of cut lever to unlock the deck position.
2. Height of cut
3. Press the pedal to move the deck to the transport position

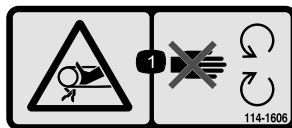

114-1606

1. Entanglement hazard, belt—keep all guards in place.

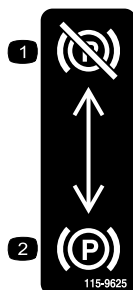

115-9625

1. Parking brake—disengaged
2. Parking brake—engaged

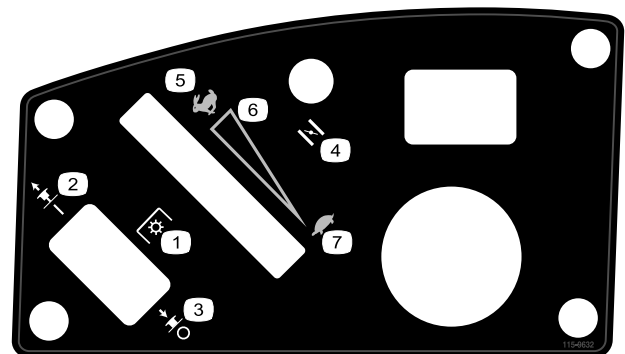

115-9632

1. Power take-off (PTO), Blade control switch on some models
2. Blade control switch—On
3. Blade control switch—Off
4. Choke
5. Fast
6. Continuous variable setting
7. Slow

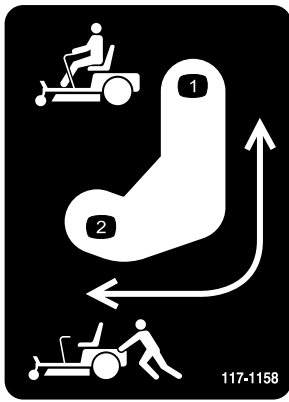

117-1158

1. Bypass lever position for operating the machine.
2. Bypass lever position for pushing the machine.

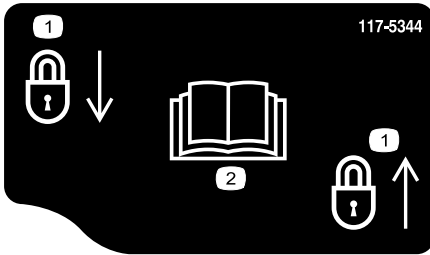

117-5344

1. Lock
2. Read the *Operator's Manual*

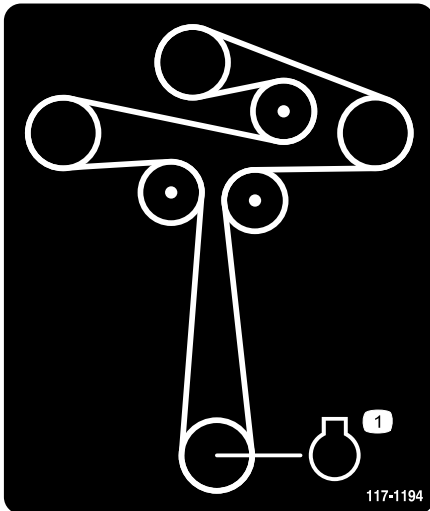

117-1194

1. Engine



Battery Symbols

Some or all of these symbols are on your battery

1. Explosion hazard
2. No fire, open flame, or smoking.
3. Caustic liquid/chemical burn hazard
4. Wear eye protection
5. Read the *Operator's Manual*.
6. Keep bystanders a safe distance from the battery.
7. Wear eye protection; explosive gases can cause blindness and other injuries
8. Battery acid can cause blindness or severe burns.
9. Flush eyes immediately with water and get medical help fast.
10. Contains lead; do not discard.



121-5686

1. Fuel
2. Full
3. Half
4. Empty

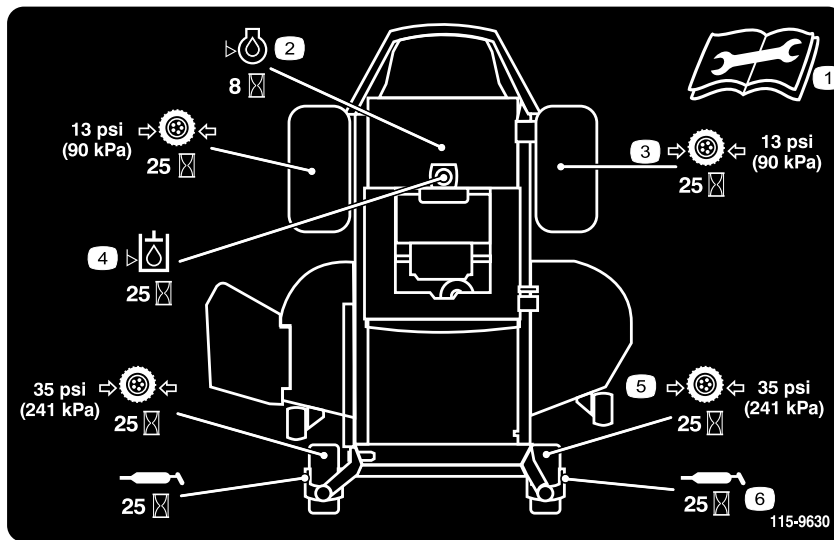

1. Read the *Operator's Manual* before performing any maintenance.
2. Check the engine oil every 8 hours
3. Check the drive wheel tire pressure every 25 hours
4. Check the hydraulic oil every 25 hours
5. Check the caster wheel tire pressure every 25 hours
6. Lubricate the caster wheel every 25 hours

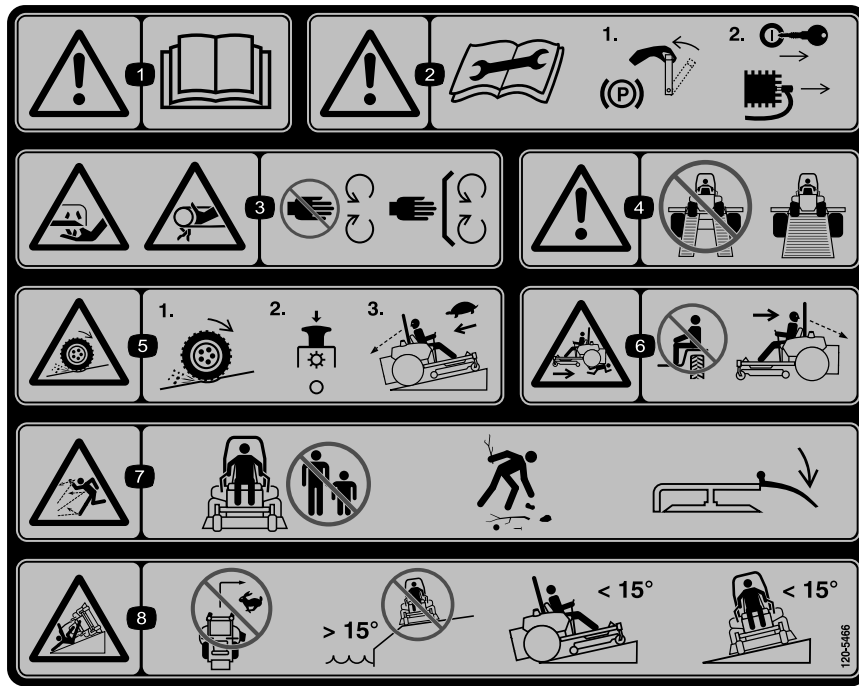

120-5466

1. Warning—read the *Operator's Manual*.
2. Warning—read the instructions before servicing or performing maintenance; move the motion control levers to the park (brake) position, remove the ignition key and disconnect the spark plug wire.
3. Cutting/dismemberment hazard, mower blade; entanglement hazard, belt—stay away from moving parts, keep all guards and shields in place.
4. Warning—do not use split ramps, use a full ramp when transporting machine.
5. Loss of traction/control hazard, slopes—loss of traction/control on a slope, disengage the blade control switch (PTO), proceed off the slope slowly.
6. Crushing/dismemberment hazard of bystanders, reversing—do not carry passengers, look behind and down when reversing.
7. Thrown object hazard—keep bystanders a safe distance from the machine, pick up debris before operating, keep deflector in place.
8. Tipping hazard—do not turn at high speeds, do not operate near drop-offs on slopes greater than 15 degrees, do not mow slopes greater than 15 degrees, avoid sudden and sharp turns while on slopes.



120-7112

1. Fuel
2. Full
3. Half
4. Empty



120-7113

1. Fuel

2. Full

3. Half

4. Empty

Setup

Loose Parts

Use the chart below to verify that all parts have been shipped.

Procedure	Description	Qty.	Use
1	No parts required	–	Connect the battery.
2	No parts required	–	Check the mower adjustment.
3	Ignition Key Hose coupling Operator's Manual Engine Operator's Manual Operator Training Material	1 1 1 1 1	Complete the Setup.

1

Connecting the Battery

No Parts Required

Procedure

1. Locate the battery and negative battery cable in the center of the machine.
2. Remove the black plastic cap from the negative battery post. Remove the fasteners from the negative battery cable and use them to secure the negative battery cable to the negative battery post (Figure 4).

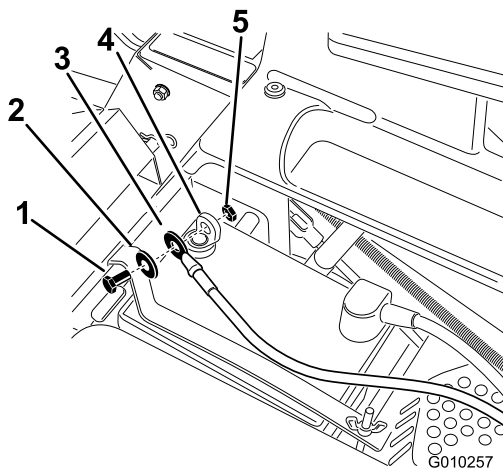

Figure 4

1. Bolt
2. Washer
3. Negative battery cable
4. Negative battery post
5. Nut

2

Checking the Mower Adjustment

No Parts Required

Procedure

Adjust the side-to-side level and the front-to-rear blade slope. Use the relevant procedures in the *Operator's Manual* to verify the deck is level and make any adjustments as necessary. Refer to the *Operator's Manual* for more information.

3

Completing the Setup

Parts needed for this procedure:

1	Ignition Key
1	Hose coupling
1	<i>Operator's Manual</i>
1	<i>Engine Operator's Manual</i>
1	Operator Training Material

Procedure

Setting Up the Motion Control Levers

If needed, remove the upper bolt, washer and nut and raise the motion control levers to the upright position. Secure the motion control levers. Refer to Adjusting the Motion Control Levers in the Operation Section.

Raising the ROPS

Raise the ROPS into the upright position and secure it in place. Refer to Using the Rollover Protection System (ROPS) in the Operation Section.

Checking the Tire Pressure

Check the front and rear tires for proper inflation. Refer to Checking the Tire Pressure in the *Operator's Manual* for the recommended inflation pressure.

Checking the Side Discharge Chute

Remove the packing restraint holding the side discharge chute up and lower the chute into place.

Checking the Engine Oil Level

Before you start the engine and use the machine, check the oil level in the engine crankcase; refer to Checking the Oil Level in the *Operator's Manual*.

Checking the Hydraulic Oil Level

Before you start the engine and use the machine, check the hydraulic oil level in the reservoir behind the seat; refer to Checking the Oil Level in the *Operator's Manual*.

Review the Remaining Parts

Keep all the following items with the machine:

- Ignition Key
- Hose coupling
- *Operator's Manual*
- *Engine Operator's Manual*
- View the Operator training material before operating the machine.

Product Overview

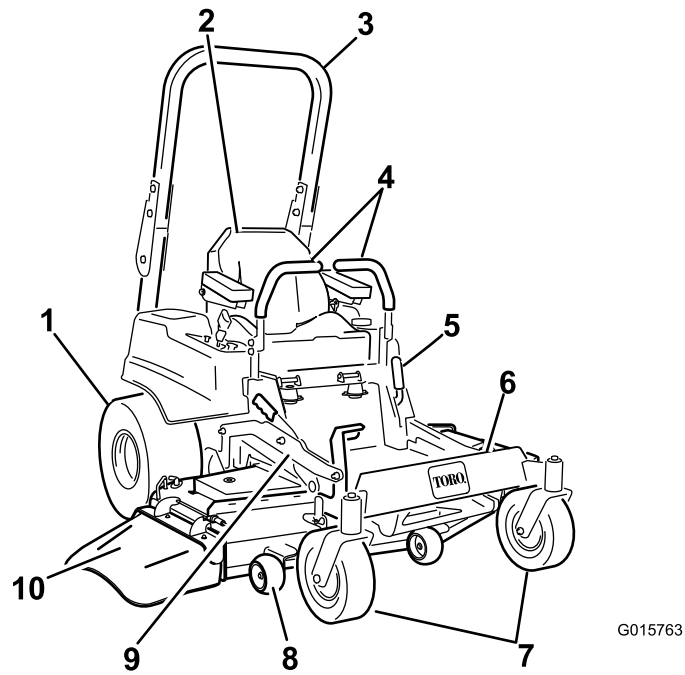

Figure 5

- | | | | |
|---------------------------------------|--------------------------|-------------------------------------------|---------------|
| 1. Drive wheel | 4. Motion control levers | 7. Front caster wheel | 10. Deflector |
| 2. Operator seat | 5. Parking brake | 8. Anti-scalp roller | |
| 3. Roll over protection system (ROPS) | 6. Footrest | 9. Foot pedal deck lift and height-of-cut | |

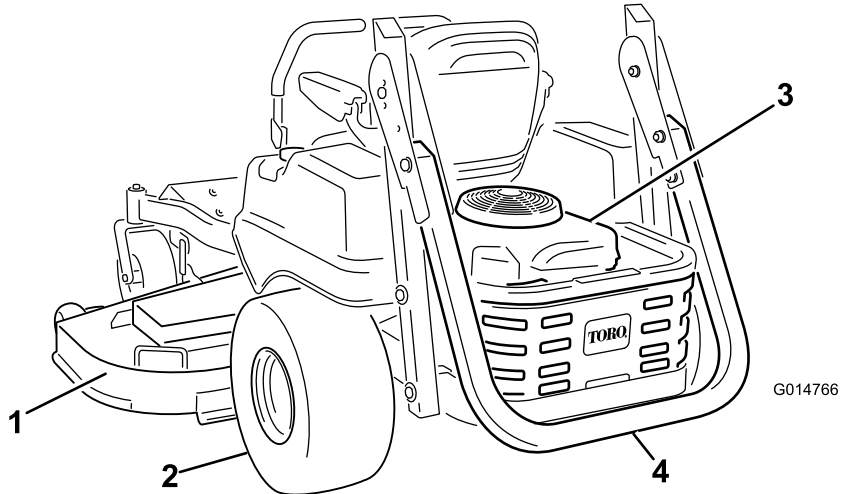

Figure 6

- | | |
|----------------|----------------------------------------------------|
| 1. Mower Deck | 3. Engine |
| 2. Drive wheel | 4. Roll over protection system (ROPS), folded down |

Controls

Become familiar with all the controls before you start the engine and operate the machine (Figure 7).

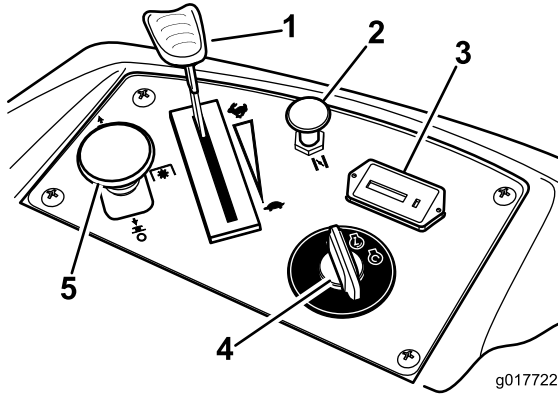

Figure 7

- 1. Throttle control
- 2. Choke
- 3. Hour meter
- 4. Ignition switch
- 5. Blade control switch (PTO)

Ignition Switch

The ignition switch has three positions: **Start**, **Run** and **Off**. The key will turn to Start and move back to Run upon release. Turning the key to the Off position will stop the engine; however, always remove the key when leaving the machine to prevent the engine from accidentally starting (Figure 7).

Throttle Control

The throttle control is variable between **Fast** and **Slow**. Moving throttle lever forward will increase engine speed and moving throttle lever to the rear will decrease engine speed. Moving the throttle forward into the detent is full throttle (Figure 7).

Choke

Use the choke to start a cold engine. Pull the choke knob up to engage it. Push down on the choke knob to disengage it.

Blade Control Switch (Power Take-Off)

The blade control switch, represented by a power take-off (PTO) symbol, engages and disengages power to the mower blades (Figure 7).

Hour Meter

The hour meter records the number of hours the blades have operated. It operates when the blade control switch (PTO) is engaged. Use these times for scheduling regular maintenance (Figure 7).

Fuel Gauge

The fuel window located below the operator position can be used to verify the level of gasoline in the tank (Figure 8).

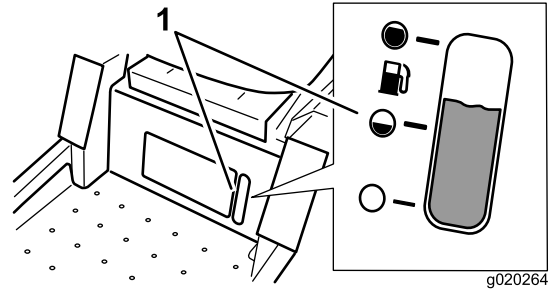

Figure 8

- 1. Fuel gauge window

Motion Control Levers

The motion control levers are speed sensitive controls of independent wheel motors. Moving a lever forward or backward turns the wheel on the same side forward or in reverse; wheel speed is proportional to the amount the lever is moved. Move the control levers outward from the center to the neutral lock position and before exiting the machine (Figure 5). Always position the motion control levers into the neutral lock position when you stop the machine or leave it unattended.

Parking Brake Lever

The parking brake lever is located on left side of the console (Figure 5). The brake lever engages a parking brake on the drive wheels. Pull the lever up and rearward to engage the brake. Push the lever forward and down to disengage the brake.

Foot Pedal Deck Lift System

The foot pedal deck lift system allows the operator to lower and raise the deck from the seated position. The operator can use the foot pedal to lift the deck briefly to avoid obstacles or lock the deck in the highest height-of-cut or transport position (Figure 5).

Height-of-Cut Lever

The height-of-cut lever works with the foot pedal to lock the deck in a specific cutting height. Only adjust the height of cut while machine is not moving (Figure 5).

Attachments/Accessories

A selection of Toro approved attachments and accessories is available for use with the machine to enhance and expand its capabilities. Contact your Authorized Service Dealer or Distributor or go to www.Toro.com for a list of all approved attachments and accessories.

Operation

Note: Determine the left and right sides of the machine from the normal operating position.

Think Safety First

Please carefully read all of the safety instructions and decals in the safety section. Knowing this information could help you, your family, pets or bystanders avoid injury.

⚠ DANGER

Mowing on wet grass or steep slopes can cause sliding and loss of control.

Wheels dropping over edges can cause rollovers, which may result in serious injury, death or drowning.

A loss of traction is a loss of steering control.

To avoid loss of control and possibility of rollover:

- Do not mow near drop-offs or near water.
- Do not mow slopes greater than 15 degrees.
- Reduce speed and use extreme caution on slopes.
- When mowing slopes, gradually work from lower to higher areas on the incline.
- Avoid sudden turns or rapid speed changes.
- Turn up, into an incline when changing directions on slopes. Turning down the slope reduces traction.
- Attachments change the handling characteristics of the machine. Use extra caution when using attachments with the machine.

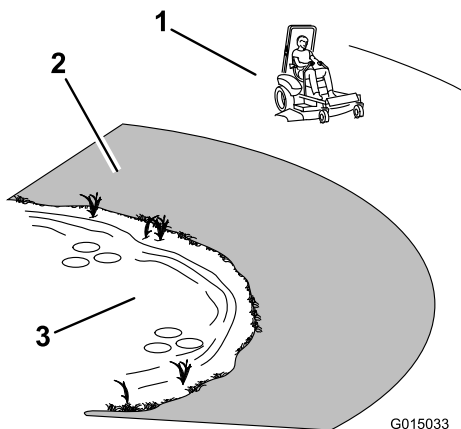

Figure 9

1. Safe Zone-use the machine here
2. Use walk behind mower and/or hand trimmer near drop-offs and water.
3. Water

Using the Rollover Protection System (ROPS)

⚠ WARNING

To avoid injury or death from rollover: keep the roll bar in the fully raised locked position and use the seat belt.

⚠ WARNING

There is no rollover protection when the roll bar is in the down position.

- Lower the roll bar only when absolutely necessary.
- Do not wear the seat belt when the roll bar is in the down position.
- Drive slowly and carefully.
- Raise the roll bar as soon as clearance permits.
- Check carefully for overhead clearances (i.e. branches, doorways, electrical wires) before driving under any objects and do not contact them.

Important: Lower the roll bar only when absolutely necessary.

1. To raise the roll bar, remove the hair cotter pin and remove the locking pins.
2. Raise the roll bar to the upright position (Figure 10).

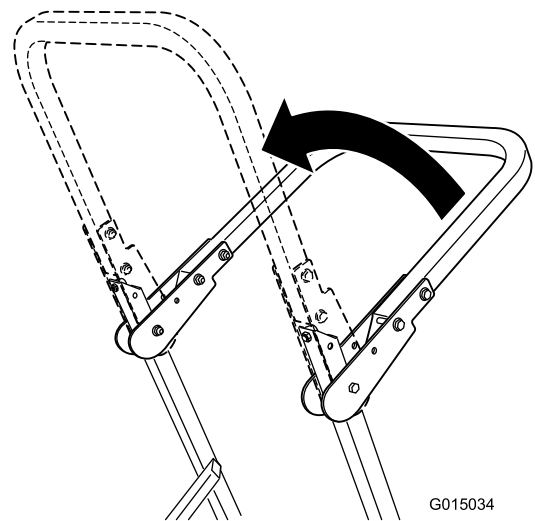

Figure 10

Important: Always use the seat belt with the roll bar in the fully raised position.

3. Install the locking pins. Secure the pins by installing the hair cotter pin (Figure 10).

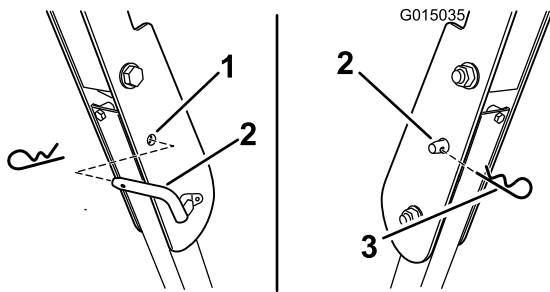

Figure 11

- | | |
|-----------------|--------------------|
| 1. Hole in ROPS | 3. Hair pin cotter |
| 2. Locking pin | |

-
4. To lower the roll bar, remove the hair cotter pin and remove the locking pin.(Figure 10).
 5. Lower the roll bar to the down position.
 6. Use the 2 locking and cotter pins to secure the bar.

Adding Fuel

- For best results, use only clean, fresh, unleaded gasoline with an octane rating of 87 or higher ((R+M)/2 rating method).
- Oxygenated fuel with up to 10% ethanol or 15% MTBE by volume is acceptable.
- **Do not** use ethanol blends of gasoline (such as E15 or E85) with more than 10% ethanol by volume. Performance problems and/or engine damage may result which may not be covered under warranty.
- **Do not** use gasoline containing methanol.
- **Do not** store fuel either in the fuel tank or fuel containers over the winter unless a fuel stabilizer is used.
- **Do not** add oil to gasoline.

⚠ DANGER

In certain conditions, gasoline is extremely flammable and highly explosive. A fire or explosion from gasoline can burn you and others and can damage property.

- Fill the fuel tank outdoors, in an open area, when the engine is cold. Wipe up any gasoline that spills.
- Never fill the fuel tank inside an enclosed trailer.
- Do not fill the fuel tank completely full. Add gasoline to the fuel tank until the level is 1/4 to 1/2 inch (6 to 13 mm) below the bottom of the filler neck. This empty space in the tank allows gasoline to expand.
- Never smoke when handling gasoline, and stay away from an open flame or where gasoline fumes may be ignited by a spark.
- Store gasoline in an approved container and keep it out of the reach of children. Never buy more than a 30-day supply of gasoline.
- Do not operate without entire exhaust system in place and in proper working condition.

⚠ DANGER

In certain conditions during fueling, static electricity can be released causing a spark which can ignite the gasoline vapors. A fire or explosion from gasoline can burn you and others and can damage property.

- Always place gasoline containers on the ground away from your vehicle before filling.
- Do not fill gasoline containers inside a vehicle or on a truck or trailer bed because interior carpets or plastic truck bed liners may insulate the container and slow the loss of any static charge.
- When practical, remove gas-powered equipment from the truck or trailer and refuel the equipment with its wheels on the ground.
- If this is not possible, then refuel such equipment on a truck or trailer from a portable container, rather than from a gasoline dispenser nozzle.
- If a gasoline dispenser nozzle must be used, keep the nozzle in contact with the rim of the fuel tank or container opening at all times until fueling is complete.

⚠ WARNING

Gasoline is harmful or fatal if swallowed. Long-term exposure to vapors can cause serious injury and illness.

- Avoid prolonged breathing of vapors.
- Keep face away from nozzle and gas tank or conditioner opening.
- Keep gas away from eyes and skin.

Using Stabilizer/Conditioner

Use a fuel stabilizer/conditioner in the machine to provide the following benefits:

- Keeps gasoline fresh during storage of 90 days or less. For longer storage it is recommended that the fuel tank be drained.
- Cleans the engine while it runs
- Eliminates gum-like varnish buildup in the fuel system, which causes hard starting

Important: Do not use fuel additives containing methanol or ethanol.

Add the correct amount of gas stabilizer/conditioner to the gas.

Note: A fuel stabilizer/conditioner is most effective when mixed with fresh gasoline. To minimize the chance of varnish deposits in the fuel system, use fuel stabilizer at all times.

Fuel Gauge

Use the fuel window below the operator to verify the level of gasoline before filling the tank (Figure 12).

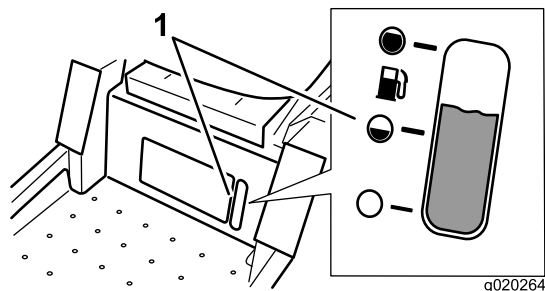

Figure 12

1. Fuel gauge window

Filling the Fuel Tank

Make sure the engine is shut off and the motion controls are in the park position.

Important: Do Not overfill fuel tank. Fill the fuel tank to the bottom of the filler neck. The empty space in the

tank allows the fuel to expand. Overfilling may result in fuel leakage or damage to the engine or emission system.

1. Clean around the fuel tank cap and remove the cap.

Note: You can use the fuel window below the operating position verify the presence of gasoline before filling the tank (Figure 12).

2. Slowly add regular, unleaded gasoline until the fuel reaches the base of the filler neck Figure 13.

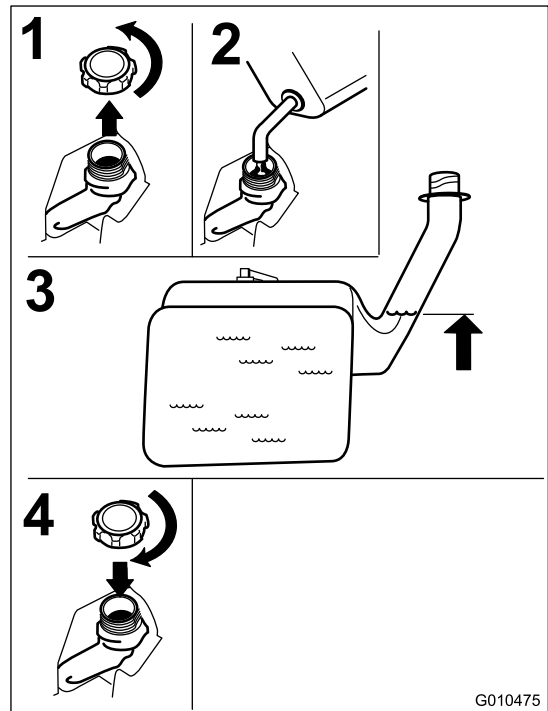

Figure 13

3. Install the fuel tank cap securely and tighten until it “clicks”. Wipe up any gasoline that may have spilled.

Checking the Engine Oil Level

Before you start the engine and use the machine, check the oil level in the engine crankcase; refer to Checking the Engine Oil Level.

Operating the Parking Brake

Always set the parking brake when you stop the machine or leave it unattended.

Setting the Parking Brake

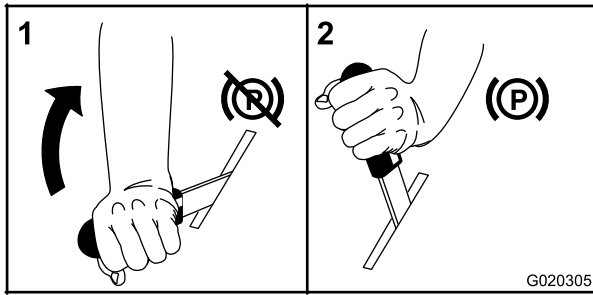

Figure 14

Releasing the Parking Brake

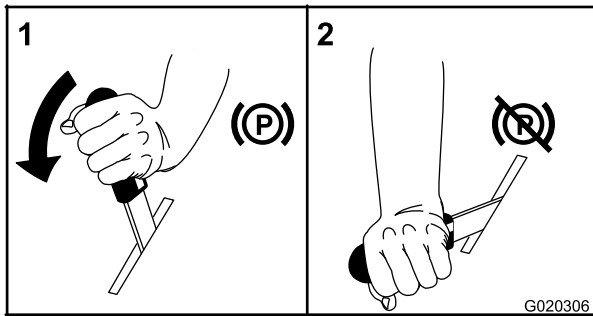

Figure 15

Operating the Throttle

The throttle control can be moved between **Fast** and **Slow** positions (Figure 16).

Always use the fast position when turning on the mower deck with the blade control switch (PTO).

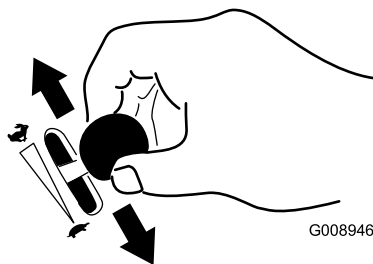

Figure 16

Operating the Choke

Use the choke to start a cold engine.

1. Pull up on the choke knob to engage the choke before using the ignition switch (Figure 17).
2. Push down on the choke to disengage the choke after the engine has started (Figure 17).

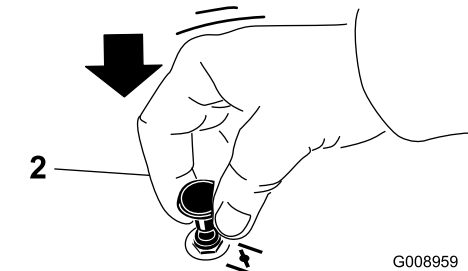
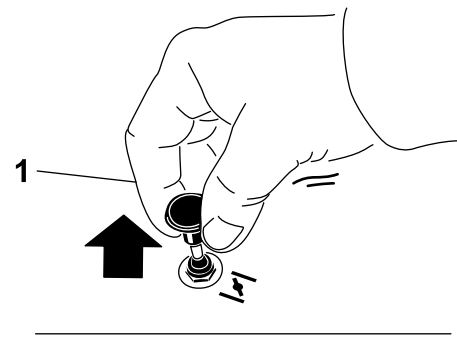

Figure 17

1. On

2. Off

Operating the Ignition Switch

1. Turn the ignition key to the Start position (Figure 18). When the engine starts, release the key.

Important: Do not engage starter for more than 5 seconds at a time. If the engine fails to start allow a 15 second cool-down period between attempts. Failure to follow these instructions can burn out the starter motor.

Note: Additional starting cycles may be required when starting the engine for the first time after the fuel system has been without fuel completely.

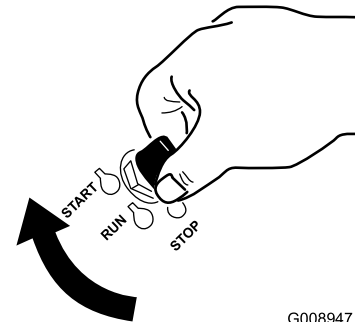

Figure 18

2. Turn the ignition key to stop to stop the engine.

Starting and Stopping the Engine

Starting the Engine

1. Sit down on the seat (Figure 19) and fasten the seat belt.
2. Move the motion controls outward to the neutral lock position (Figure 19).
3. Set the parking brake (Figure 19); refer to Setting the Parking Brake.
4. Move the blade control switch (PTO) to the Off position (Figure 19).
5. Pull up on the Choke control before starting a cold engine.

Note: A warm or hot engine may not require choking.

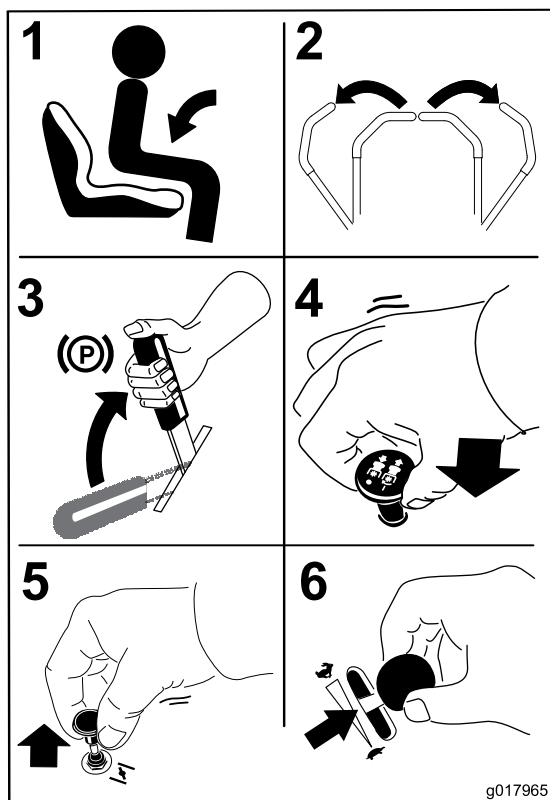

Figure 19

Note: If the fuel system was depleted of fuel—add fuel to the machine and use additional starting cycles when starting the engine.

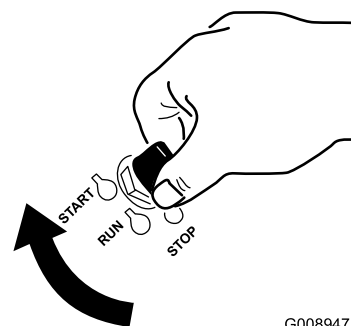

Figure 20

1. Off
2. Run
3. Start

Stopping the Engine

⚠ CAUTION

Children or bystanders can be injured if they move or attempt to operate the tractor while it is unattended.

Always remove the ignition key and set the parking brake when leaving the machine unattended, even if just for a few minutes.

6. Turn the ignition key to the Start position (Figure 18). When the engine starts, release the key.

Important: Do not engage starter for more than 5 seconds at a time. If the engine fails to start allow a 15 second cool-down period between attempts. Failure to follow these instructions can burn out the starter motor.

7. After the engine starts, push down on the Choke control. If the engine stalls or hesitates, pull up on the Choke control and let the engine run for a few seconds. Then push down the Choke control. Repeat as required.

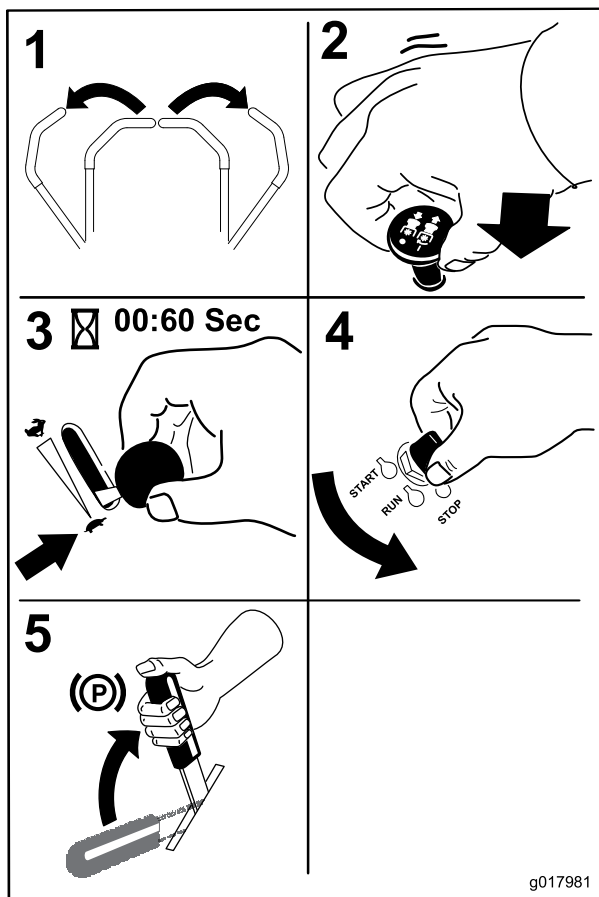

Figure 21

Operating the Mower Blade Control Switch (PTO)

The blade control switch (PTO) starts and stops the mower blades and any powered attachments.

Engaging the Blade Control Switch (PTO)

Engage the blade control switch (PTO) with the throttle position at Fast.

Note: Engaging the blade control switch (PTO) with the throttle position at half or less will cause excessive wear to the drive belts.

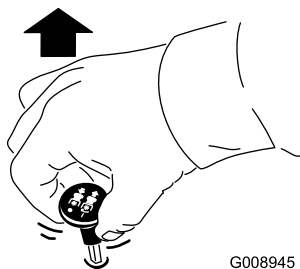

Figure 22

Disengaging the Blade Control Switch (PTO)

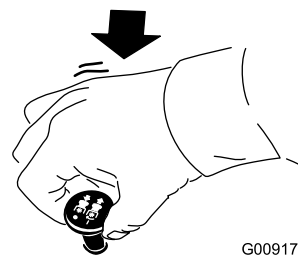

Figure 23

The Safety Interlock System

⚠ WARNING

If safety interlock switches are disconnected or damaged the machine could operate unexpectedly causing personal injury.

- Do not tamper with the interlock switches.
- Check the operation of the interlock switches daily and replace any damaged switches before operating the machine.

Understanding the Safety Interlock System

The safety interlock system is designed to prevent the engine from starting unless:

- The parking brake is engaged.
- The blades are disengaged.
- The motion control levers are in the neutral lock position.

The safety interlock system also is designed to stop the engine when the control levers are out of the neutral lock position with the parking brake on or if you rise from the seat when the blades are engaged.

Testing the Safety Interlock System

Test the safety interlock system before you use the machine each time. If the safety system does not operate as described below, have an Authorized Service Dealer repair the safety system immediately.

1. While sitting on the seat, engage the parking brake and move the blade control switch to On. Try starting the engine; the engine should not crank.
2. While sitting on the seat, engage the parking brake and move the blade control switch to Off. Move either motion control lever (forward or reverse). Try starting the engine; the engine should not crank. Repeat with the other motion control lever.

3. While sitting on the seat, engage the parking brake, move the blade control switch to Off, and lock the motion control levers in neutral. Start the engine. While the engine is running, release the parking brake, engage the blade control switch, and rise slightly from the seat; the engine should stop.
4. While sitting on the seat, engage the parking brake, move the blade control switch to Off, and lock the motion control levers in neutral. Start the engine. While the engine is running, center the motion controls; the engine should stop.

Driving Forward or Backward

The throttle control regulates the engine speed as measured in rpm (revolutions per minute). Place the throttle control in the fast position for best performance. Always operate in the full throttle position when mowing.

CAUTION

Machine can spin very rapidly. Operator may lose control of machine and cause personal injury or damage to machine.

- Use caution when making turns.
- Slow the machine down before making sharp turns.

Using the Motion Control Levers

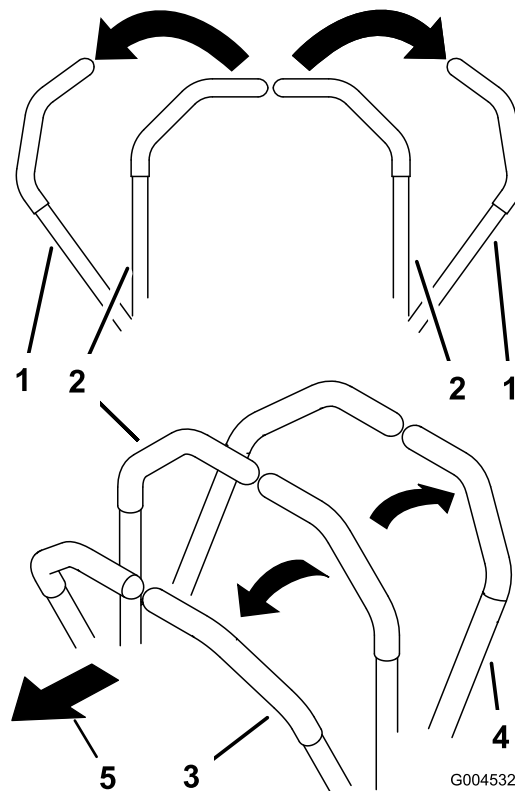

Figure 24

- | | |
|-----------------------------------------------|-------------|
| 1. Motion control lever-neutral lock position | 3. Forward |
| 2. Center, unlocked position | 4. Backward |

Driving Forward

Note: The engine will kill if the traction control levers are moved with the parking brake engaged.

1. Release the parking brake; refer to Releasing the Parking Brake in Operation.
2. Move the levers to the center, unlocked position.
3. To go forward, slowly push the motion control levers forward (Figure 25).

Stopping the Machine

To stop the machine, move the traction control levers to neutral and move to locked position, disengage the blade control switch (PTO), and turn the ignition key to off.

Set the parking brake when you leave the machine; refer to [Operating the Parking Brake \(page 20\)](#). Remember to remove the key from the ignition switch ([Figure 21](#)).

⚠ CAUTION

Children or bystanders may be injured if they move or attempt to operate the tractor while it is unattended.

Always remove the ignition key and set the parking brake when leaving the machine unattended, even if just for a few minutes.

Adjusting the Height of Cut

The machine is equipped with a foot pedal deck lift system. The operator can use the foot pedal to lift the deck briefly to avoid obstacles or lock the deck in the highest height-of-cut or transport position. The operator can use the height of cut lever with the foot pedal to lock the deck in a specific cutting height.

Using the Foot Pedal Deck Lift System

1. Press the pedal down to raise the deck; continue to press the pedal until the deck is locked in the transport position ([Figure 27](#)).
2. Push on the deck lift pedal with your foot and raise the height-of-cut lever slightly to disengage the transport lock.

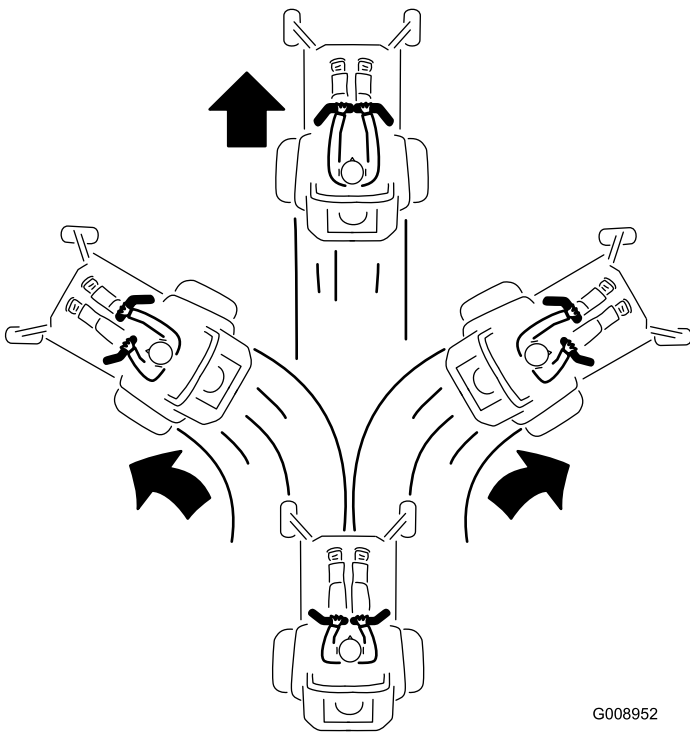

Figure 25

G008952

Driving Backward

1. Move the levers to the center, unlocked position.
2. To go backward, slowly pull the motion control levers rearward ([Figure 26](#)).

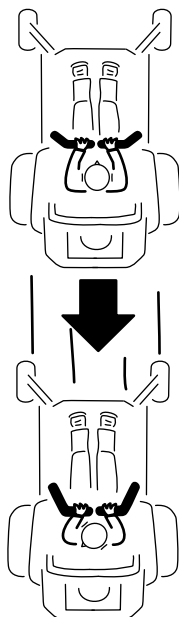

Figure 26

G008953

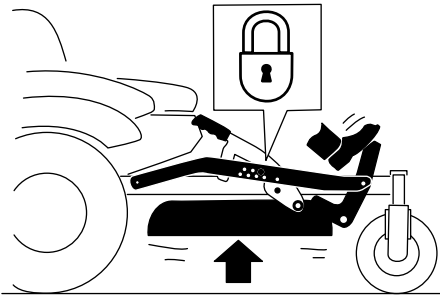
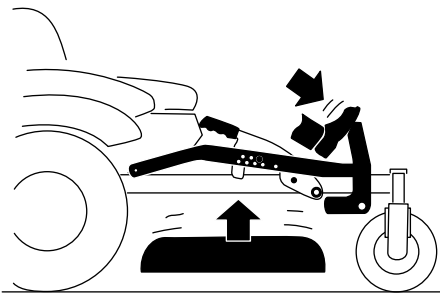

Figure 27

Transport Lock Position

G010219

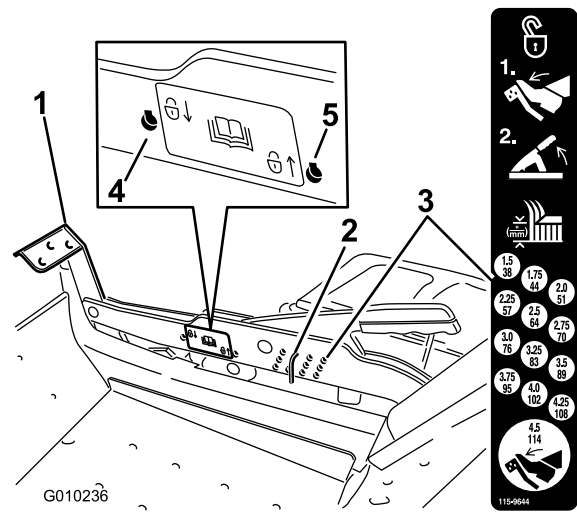

Figure 28

1. Deck lift pedal
2. Cut height pin
3. Height-of-cut positions
4. Lock position. lowest height-of-cut (use only for deck removal)
5. Lock position. transport position

Adjusting the Height-of-Cut

The height-of-cut can be adjusted from 1-1/2 to 4-1/2 inch (38 to 114 mm) in 1/4 inch (6 mm) increments by relocating the height-of-cut pin into different hole locations.

1. Push on the deck lift pedal with your foot and raise the mower deck to the transport position (also the 4-1/2 inch (114 mm) cutting height position) (Figure 28).
2. To adjust, remove the pin from the height-of-cut bracket (Figure 28).
3. Select a hole in the height-of-cut system corresponding to the height-of-cut desired and, insert the pin (Figure 28).
4. Push on the deck lift pedal with your foot and raise the height-of-cut lever slightly to disengage the transport lock.
5. Lower the deck slowly until the pin makes contact with the lever.

Using the Lock Positions

The deck can be locked in the highest height-of-cut or transport position or the lowest height-of-cut position.

To lock the deck in the transport position:

1. Push on the deck lift pedal with your foot, and raise the mower deck to the transport position (also the 4.5 inch (114 mm) cutting height position) (Figure 28).
2. Remove the pin from the height-of-cut bracket (Figure 28).
3. Select the lower hole on the lock decal and insert the pin (Figure 28).

To lock the deck in the lowest height-of-cut position:

1. Push on the deck lift pedal with your foot, and raise the mower deck to the transport position (also the 4.5 inch (114 mm) cutting height position) (Figure 28).
2. Remove the pin from the height-of-cut bracket (Figure 28).
3. Push on the deck lift pedal with your foot and lower the mower deck to the lowest position..
4. Select the upper hole on the lock decal and insert the pin (Figure 28).

Adjusting the Anti-Scalp Rollers

Whenever you change the height-of-cut, it is recommended to adjust the height of the anti-scalp rollers.

1. Disengage the blade control switch (PTO), move the motion control levers to the neutral lock position and set the parking brake.
2. Stop the engine, remove the key, and wait for all moving parts to stop before leaving the operating position.
3. Adjust the anti-scalp rollers as shown in [Figure 29](#) to match the closest height-of-cut position.

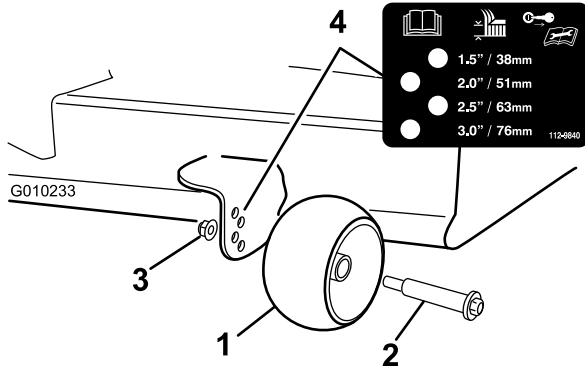

Figure 29

- | | |
|----------------------|-----------------|
| 1. Anti-scalp roller | 3. Flange Nut |
| 2. Bolt | 4. Hole spacing |

Positioning the Seat

The seat can move forward and backward. Position the seat where you have the best control of the machine and are most comfortable.

To adjust, move the lever sideways to unlock seat ([Figure 30](#)).

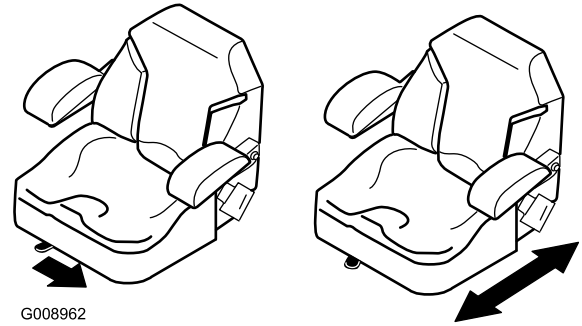

Figure 30

Adjusting the Motion Control Levers

Adjusting the Height

The motion control levers can be adjusted higher or lower for maximum operator comfort.

1. Remove the 2 bolts and 2 washers holding the control lever to the control arm shaft ([Figure 31](#)).
2. Move the control lever to the next set of holes. Secure the lever with the 2 bolts and 2 washers ([Figure 31](#)).

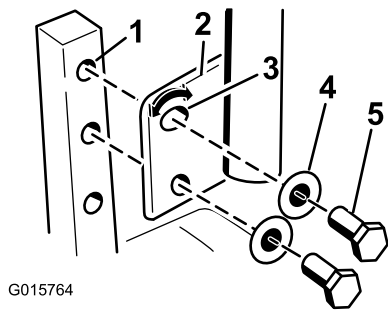

Figure 31

1. Control arm shaft
2. Control lever
3. Slotted, upper hole

4. Washer
5. Bolt

-
3. Repeat the adjustment for the opposite control lever.

Adjusting the Tilt

The motion control levers can be tilted forward or backward for maximum operator comfort.

1. Loosen the upper bolt holding the control lever to the control arm shaft.
2. Loosen the lower bolt just enough to pivot the control lever forward or backward.
3. Tighten both bolts to secure the control in the new position.
4. Repeat the adjustment for the opposite control lever.

Pushing the Machine by Hand

Important: Always push the machine by hand. Machine damage can occur when the machine is towed.

To Push the Machine

1. Park the machine on a level surface and disengage the blade control switch.
 2. **Engage** the parking brake.
 3. Move the motion control levers outward to neutral lock position, stop the engine, remove the key, and wait for all moving parts to stop before leaving the operating position.
 4. Locate the bypass levers at the rear of the machine, on the left and right side of the frame.
 5. Move the bypass levers rearward and then down to lock them in place as shown in [Figure 32](#) to disengage the wheel motors.
- Note:** Ensure that the left and right bypass levers are rearward and locked before moving the machine.
6. **Disengage** the parking brake.

The machine is now able to be pushed by hand.



Figure 32

To Operate the Machine

Move the bypass to the position for operating the machine (Figure 32) to engage the wheel motors.

Using the Side Discharge

The mower has a hinged grass deflector that disperses clippings to the side and down toward the turf.

⚠ DANGER

Without a grass deflector, discharge cover, or complete grass catcher assembly mounted in place, you and others are exposed to blade contact and thrown debris. Contact with rotating mower blade(s) and thrown debris will cause injury or death.

- Never remove the grass deflector from the mower because the grass deflector routes material down toward the turf. If the grass deflector is ever damaged, replace it immediately.
- Never put your hands or feet under the mower.
- Never try to clear the discharge area or mower blades unless you move the blade control switch (PTO) to the off position, rotate the ignition key to off and remove the key.
- Make sure the grass deflector is in the down position.

Operating Tips

Fast Throttle Setting

For best mowing and maximum air circulation, operate the engine at the fast throttle position. Air is required to thoroughly cut grass clippings, so do not set the height-of-cut so low as to totally surround the mower by uncut grass. Always try to have one side of the mower free from uncut grass, which allows air to be drawn into the mower.

Cutting a Lawn for the First Time

Cut grass slightly longer than normal to ensure the cutting height of the mower does not scalp any uneven ground. However, the cutting height used in the past is generally the best one to use. When cutting grass longer than six inches tall, you may want to cut the lawn twice to ensure an acceptable quality of cut.

Cut 1/3 of the Grass Blade

It is best to cut only about 1/3 of the grass blade. Cutting more than that is not recommended unless grass is sparse, or it is late fall when grass grows more slowly.

Mowing Direction

Alternate mowing direction to keep the grass standing straight. This also helps disperse clippings which enhances decomposition and fertilization.

Mow at Correct Intervals

Normally, mow every four days. But remember, grass grows at different rates at different times. So to maintain the same cutting height, which is a good practice, mow more often in early spring. As the grass growth rate slows in mid summer, mow less frequently. If you cannot mow for an extended period, first mow at a high cutting height; then mow again two days later at a lower height setting.

Cutting Speed

To improve cut quality, use a slower ground speed in certain conditions.

Avoid Cutting Too Low

If the cutting width of the mower is wider than the mower you previously used, raise the cutting height to ensure that uneven turf is not cut too short.

Long Grass

If the grass is ever allowed to grow slightly longer than normal, or if it contains a high degree of moisture, raise the

cutting height higher than usual and cut the grass at this setting. Then cut the grass again using the lower, normal setting.

When Stopping

If the machine's forward motion must be stopped while mowing, a clump of grass clippings may drop onto your lawn. To avoid this, move onto a previously cut area with the blades engaged.

Keep the Underside of the Mower Clean

Clean clippings and dirt from the underside of the mower after each use. If grass and dirt build up inside the mower, cutting quality will eventually become unsatisfactory.

Blade Maintenance

Maintain a sharp blade throughout the cutting season because a sharp blade cuts cleanly without tearing or shredding the grass blades. Tearing and shredding turns grass brown at the edges, which slows growth and increases the chance of disease. Check the cutter blades daily for sharpness, and for any wear or damage. File down any nicks and sharpen the blades as necessary. If a blade is damaged or worn, replace it immediately with a genuine Toro replacement blade.

Maintenance

Recommended Maintenance Schedule(s)

Maintenance Service Interval	Maintenance Procedure
After the first 8 hours	<ul style="list-style-type: none">• Change the engine oil.
After the first 50 hours	<ul style="list-style-type: none">• Change the hydraulic system filter and oil.
Before each use or daily	<ul style="list-style-type: none">• Check the safety interlock system.• Check the engine oil level.• Clean the air intake screen.• Check the mower blades.• Inspect the grass deflector for damage
After each use	<ul style="list-style-type: none">• Clean the mower housing.
Every 25 hours	<ul style="list-style-type: none">• Grease all lubrication points.• Check tire pressure.• Check the hydraulic oil level in the expansion tank.
Every 50 hours	<ul style="list-style-type: none">• Inspect the belts for cracks and wear.
Every 100 hours	<ul style="list-style-type: none">• Service the paper element. (more often in dusty, dirty conditions)• Change the engine oil. (more often in dusty, dirty conditions)• Check the spark plug(s).• Replace the fuel filters (more often under dusty, dirty conditions).
Every 200 hours	<ul style="list-style-type: none">• Replace the paper element. (more often in dusty, dirty conditions)• Change the oil filter. (more often in dusty, dirty conditions)
Every 400 hours	<ul style="list-style-type: none">• Change the hydraulic system filter and oil.
Monthly	<ul style="list-style-type: none">• Check the battery charge.
Yearly or before storage	<ul style="list-style-type: none">• Paint chipped surfaces.• Check all maintenance procedures listed above before storage.

Important: Refer to your engine operator's manual for additional maintenance procedures.

▲ CAUTION

If you leave the key in the ignition switch, someone could accidentally start the engine and seriously injure you or other bystanders.

Remove the key from the ignition and disconnect the wire from the spark plug before you do any maintenance. Set the wire aside so that it does not accidentally contact the spark plug.

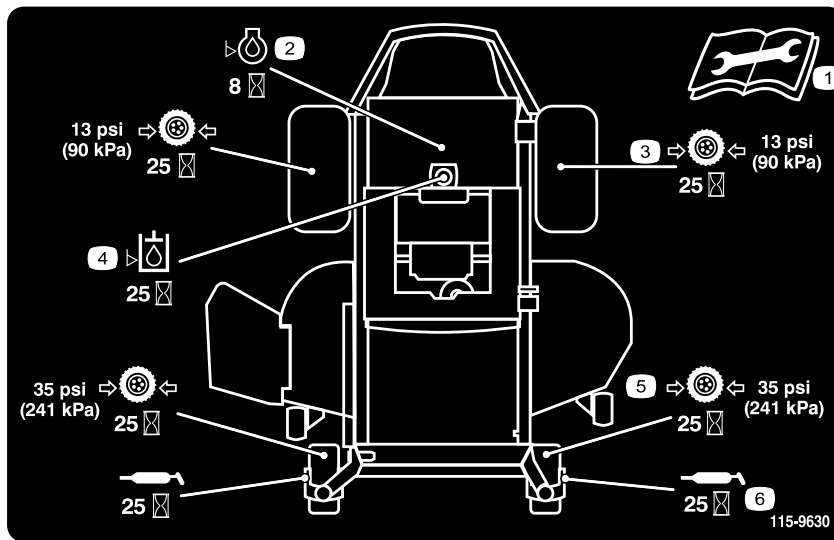

Figure 33

Located on the seat pan underside

- | | |
|-----------------------------------------------------------------------------------------------------------------------------------------------------------------------------------------------------------------------------------------|-------------------------------------------------------------------------------------------------------------------------------------------------------------------------------------------------------------------|
| <ol style="list-style-type: none"> 1. Read the <i>Operator's Manual</i> before performing any maintenance. 2. Check the engine oil every 8 hours 3. Check the drive wheel tire pressure every 25 hours | <ol style="list-style-type: none"> 4. Check the hydraulic oil every 25 hours 5. Check the caster wheel tire pressure every 25 hours 6. Lubricate the caster wheel every 25 hours |
|-----------------------------------------------------------------------------------------------------------------------------------------------------------------------------------------------------------------------------------------|-------------------------------------------------------------------------------------------------------------------------------------------------------------------------------------------------------------------|

Premaintenance Procedures

Raising the Seat

Make sure the motion control levers are in the neutral lock position and parking brake is set. Lift and hold the lever behind the seat forward to disengage the seat latch and then lift the seat forward.

The following components can be accessed by raising the seat:

- Service decal
- Fuses
- Battery and cables

Lubrication

Greasing the Bearings

Service Interval: Every 25 hours—Grease all lubrication points.

Grease Type: No. 2 General Purpose Lithium Base Grease

1. Park the machine on a level surface and disengage the blade control switch.
2. Move the motion control levers outward to the neutral position, set the parking brake, stop the engine, remove the key, and wait for all moving parts to stop before leaving the operating position.
3. Clean the grease fittings (Figure 33 and Figure 34) with a rag. Make sure to scrape any paint off of the front of the fitting(s).

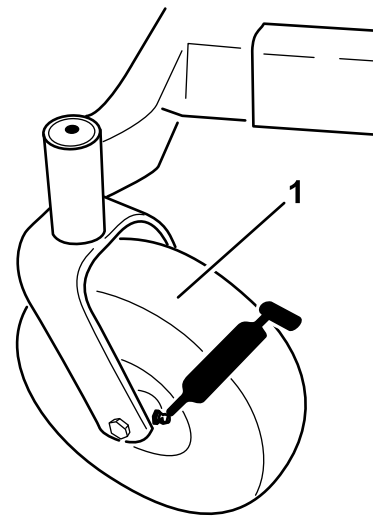

G009949

Figure 34

1. Front caster tire

-
4. Connect a grease gun to each fitting (Figure 34 and Figure 33). Pump grease into the fittings until grease begins to ooze out of the bearings.
 5. Wipe up any excess grease.

Engine Maintenance

⚠ WARNING

Contact with hot surfaces may cause personal injury.

Keep hands, feet, face, clothing and other body parts away the muffler and other hot surfaces.

Servicing the Air Cleaner

Note: Service the air cleaner more frequently (every few hours) if operating conditions are extremely dusty or sandy.

Removing the Element

1. Park the machine on a level surface and disengage the blade control (PTO).
2. Move the motion control levers outward to the neutral position, set the parking brake, stop the engine, remove the key, and wait for all moving parts to stop before leaving the operating position.
3. Clean around the air cleaner cover to prevent dirt from getting into the engine and causing damage.
4. Lift the cover and remove the hose clamp securing the air cleaner assembly to the engine (Figure 35).
5. Loosen the hose clamp and remove the paper element (Figure 35).

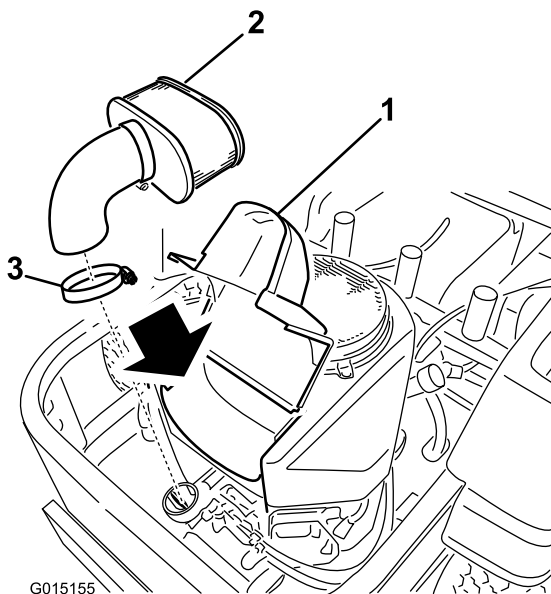

Figure 35

1. Cover
2. Paper element
3. Hose clamp

Cleaning the Element

Service Interval: Every 100 hours—Service the paper element. (more often in dusty, dirty conditions)

Every 200 hours/Yearly (whichever comes first)—Replace the paper element. (more often in dusty, dirty conditions)

1. Lightly tap the element on a flat surface to remove dust and dirt.
2. Inspect the element for tears, an oily film, and damage to the seal.

Important: Never clean the paper element with pressurized air or liquids, such as solvent, gas, or kerosene. Replace the paper element if it is damaged or cannot be cleaned thoroughly.

Servicing the Engine Oil

Oil Type: Detergent oil (API service SF, SG, SH, SJ, or SL)

Crankcase Capacity: 1.8 L (61 ounces); when oil filter is removed: 2.1 L (70 ounces)

Viscosity: See the table below.

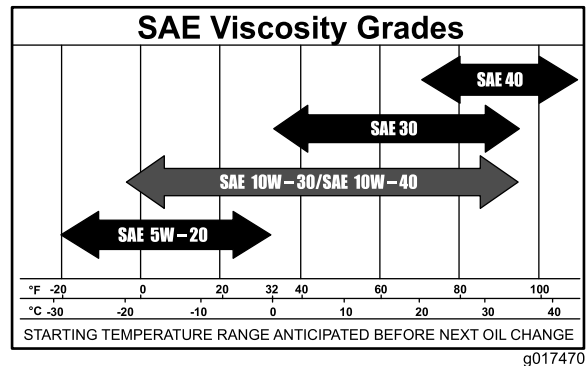

Figure 36

Note: Using multi grade oils (5W-20, 10W-30, and 10W -40) will increase oil consumption. Check oil level more frequently when using them.

Checking the Engine Oil Level

Service Interval: Before each use or daily

Note: Check the oil when the engine is cold.

⚠ WARNING

Contact with hot surfaces may cause personal injury.

Keep hands, feet, face, clothing and other body parts away the muffler and other hot surfaces.

Important: Do not overfill the crankcase with oil because damage to the engine may result. Do not run

engine with oil below the low mark because the engine may be damaged.

1. Park the machine on a level surface, disengage the blade control switch, stop the engine, engage parking brake, and remove the key.
2. Make sure the engine is stopped, level, and is cool so the oil has had time to drain into the sump.
3. To keep dirt, grass clippings, etc., out of the engine, clean the area around the oil fill cap/dipstick before removing it (Figure 37).

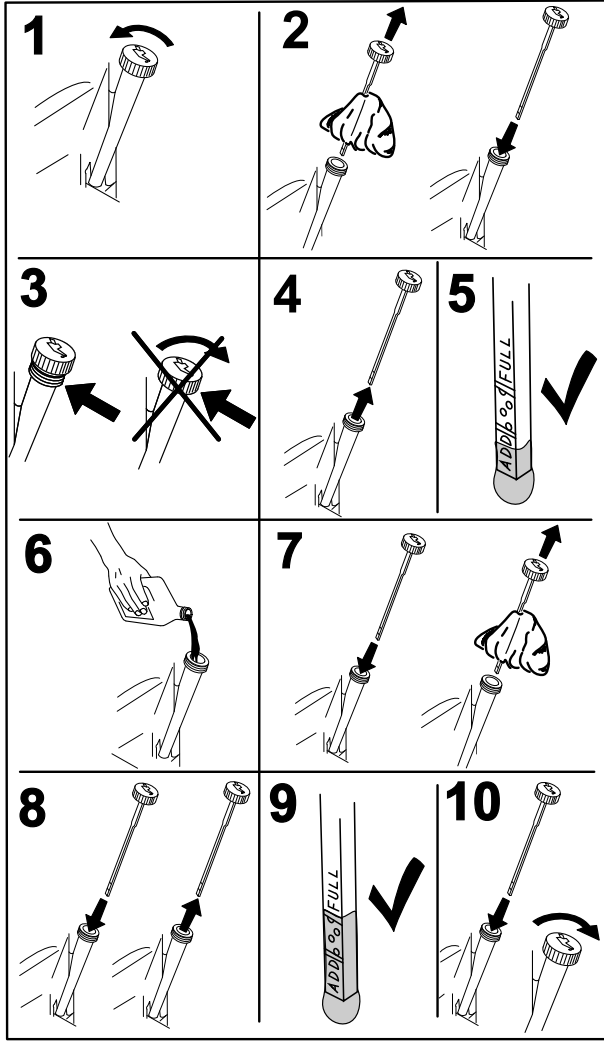

Figure 37

2. Disengage the PTO, move the motion control levers to the neutral locked position and set the parking brake.
3. Stop the engine, remove the key, and wait for all moving parts to stop before leaving the operating position.

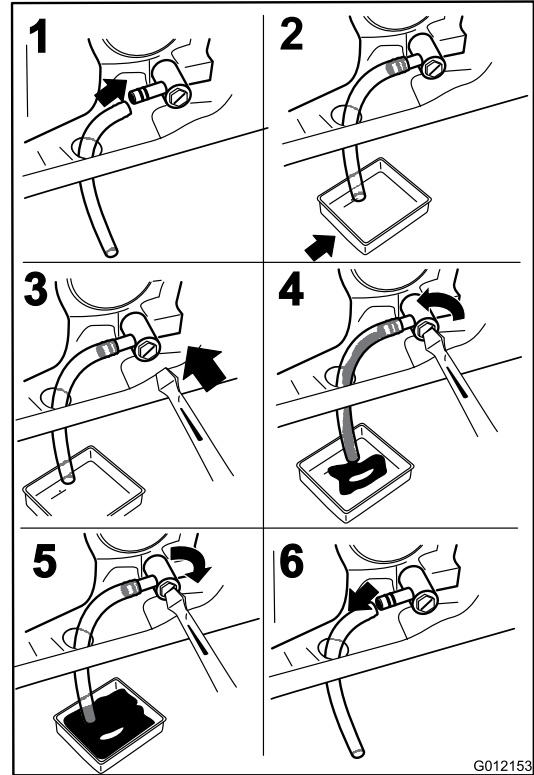

Figure 38

Changing the Engine Oil

Service Interval: After the first 8 hours—Change the engine oil.

Every 100 hours—Change the engine oil. (more often in dusty, dirty conditions)

Note: Dispose of the used oil at a recycling center.

1. Park the machine so that the drain side is slightly lower than the opposite side to assure the oil drains completely.

- Slowly pour approximately 80% of the specified oil into the filler tube and slowly add the additional oil to bring it to the **Full** mark (Figure 39).

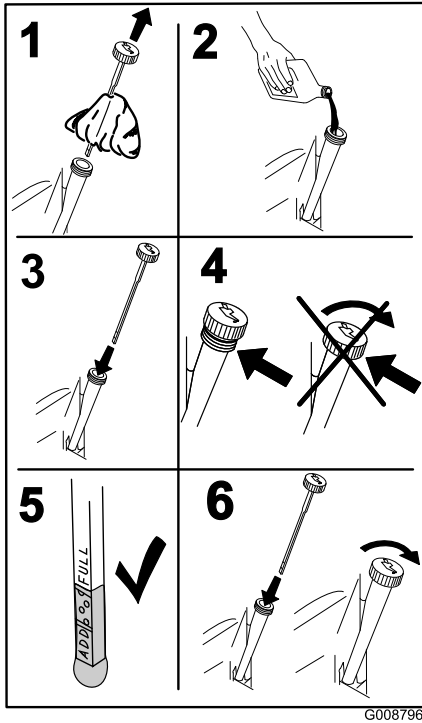

Figure 39

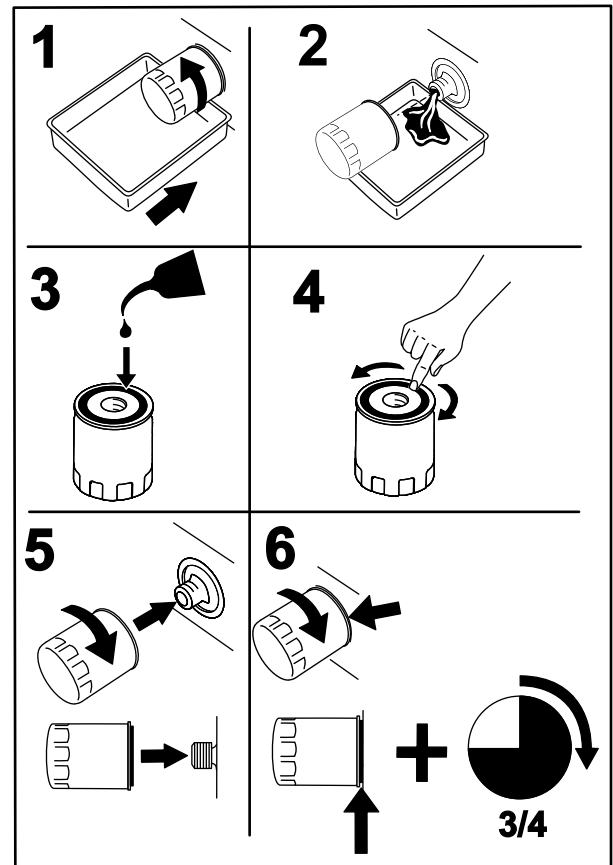

Figure 40

Changing the Engine Oil Filter

Service Interval: Every 200 hours—Change the oil filter.
(more often in dusty, dirty conditions)

Note: Change the engine oil filter more frequently when operating conditions are extremely dusty or sandy.

- Drain the oil from the engine; refer to [Changing the Engine Oil](#) (page 35).
- Change the engine oil filter (Figure 40).

Note: Ensure the oil filter gasket touches the engine and then an extra 3/4 turn is completed.

- Fill the crankcase with the proper type of new oil; refer to [Changing the Oil](#).

Servicing the Spark Plug

Service Interval: Every 100 hours—Check the spark plug(s).

Make sure the air gap between the center and side electrodes is correct before installing the spark plug. Use a spark plug wrench for removing and installing the spark plug(s) and a gapping tool/feeler gauge to check and adjust the air gap. Install a new spark plug(s) if necessary.

Type: NGK BPR4ES (or equivalent)

Air Gap: 0.030 inch (0.76 mm)

Removing the Spark Plug

1. Disengage the PTO, move the motion control levers to the neutral locked position and set the parking brake.
2. Stop the engine, remove the key, and wait for all moving parts to stop before leaving the operating position.

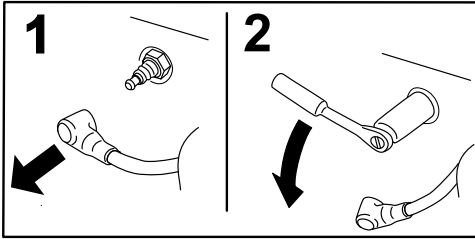

G008791

Figure 41

Note: Blowing out the cavity with compressed air is usually the most effective method for cleaning. The spark plug is most accessible when the blower housing is removed for cleaning.

Checking the Spark Plug

Important: Never clean the spark plug(s). Always replace the spark plug(s) when it has a black coating, worn electrodes, an oily film, or cracks.

If you see light brown or gray on the insulator, the engine is operating properly. A black coating on the insulator usually means the air cleaner is dirty.

Set the gap to 0.030 inches (0.76 mm).

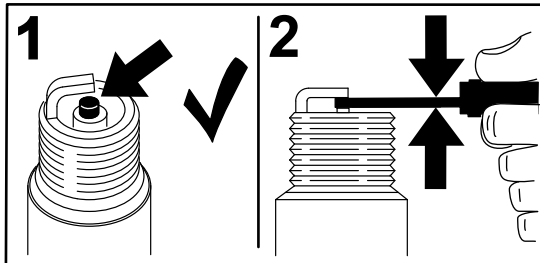

G008794

Figure 42

Installing the Spark Plug

Tighten the spark plug(s) to 16 ft-lb (22 N-m).

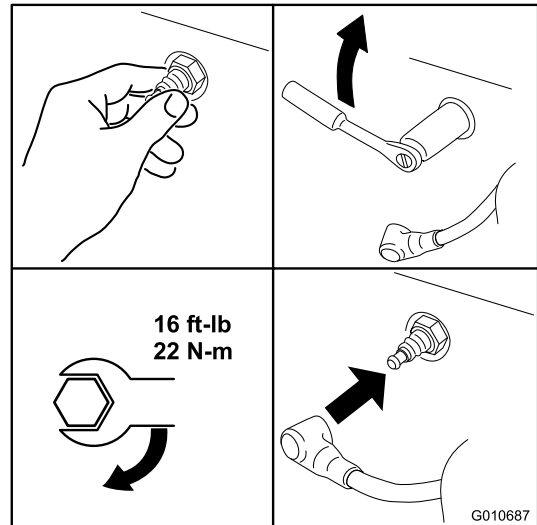

G010687

Figure 43

Cleaning the Cooling System

Clean the air intake screen from grass and debris before each use.

1. Disengage the blade control switch, move the control levers to the neutral locked position, and apply the parking brake.
2. Stop the engine, remove the key, and wait for all moving parts to stop before leaving the operating position.
3. Remove the air intake screen, air cleaner cover, and fan housing.
4. Clean debris and grass from the parts.
5. Install the air intake screen, air cleaner cover, and fan housing.

Fuel System Maintenance

⚠ DANGER

In certain conditions, gasoline is extremely flammable and highly explosive. A fire or explosion from gasoline can burn you and others and can damage property.

- Perform any fuel related maintenance when the engine is cold. Do this outdoors in an open area. Wipe up any gasoline that spills.
- Never smoke when draining gasoline, and stay away from an open flame or where a spark may ignite the gasoline fumes.

Replacing the Fuel Filter

Service Interval: Every 100 hours/Yearly (whichever comes first) (more often under dusty, dirty conditions).

1. Disengage the blade control switch (PTO), move the motion control levers to the neutral lock position, and set the parking brake.
2. Stop the engine, remove the key, and wait for all moving parts to stop before leaving the operating position.
3. Allow the machine to cool down.
4. Raise the seat and locate the fuel filters as shown in [Figure 44](#).

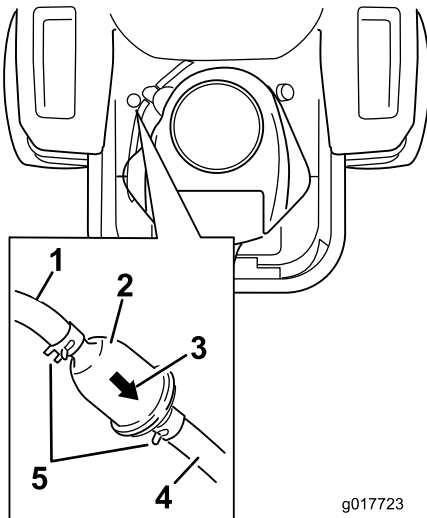

Figure 44

1. Fuel line from tank
2. In-line Fuel filter
3. Flow direction arrow
4. Fuel line to engine
5. Hose clamp

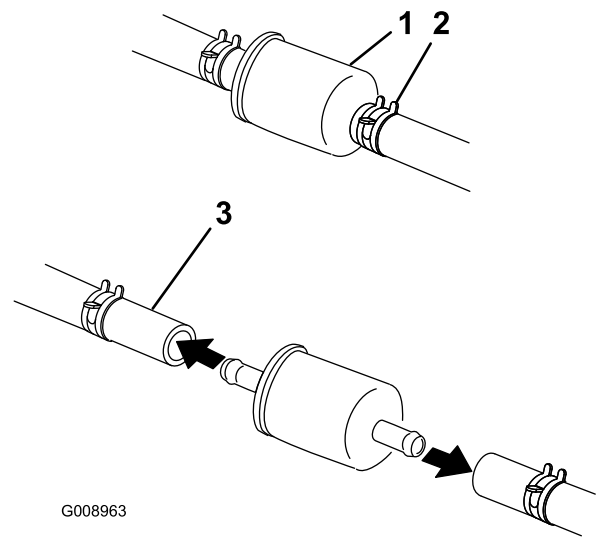

Figure 45

1. Fuel filter
2. Hose clamp
3. Fuel line

6. Remove the filter from the fuel lines.
7. Install a new filter with the flow direction arrow coming from the fuel tank and pointing to the engine. Move the hose clamps close to the filter ([Figure 44](#)) to secure it in place.

5. Squeeze the ends of the hose clamps together and slide them away from the filter ([Figure 45](#)).

Electrical System Maintenance

Servicing the Battery

Service Interval: Monthly

WARNING

CALIFORNIA Proposition 65 Warning

Battery posts, terminals, and related accessories contain lead and lead compounds, chemicals known to the State of California to cause cancer and reproductive harm. Wash hands after handling.

⚠ DANGER

Battery electrolyte contains sulfuric acid, which is a deadly poison and causes severe burns.

Do not drink electrolyte, and avoid contact with skin, eyes or clothing. Wear safety glasses to shield your eyes and rubber gloves to protect your hands.

Removing the Battery

⚠ WARNING

Battery terminals or metal tools could short against metal machine components causing sparks. Sparks can cause the battery gasses to explode, resulting in personal injury.

- When removing or installing the battery, do not allow the battery terminals to touch any metal parts of the machine.
- Do not allow metal tools to short between the battery terminals and metal parts of the machine.

⚠ WARNING

Incorrect battery cable routing could damage the machine and cables causing sparks. Sparks can cause the battery gasses to explode, resulting in personal injury.

- Always disconnect the negative (black) battery cable before disconnecting the positive (red) cable.
- Always reconnect the positive (red) battery cable before reconnecting the negative (black) cable.

1. Disengage the blade control switch (PTO), move the motion control levers to the neutral lock position and set the parking brake.
2. Stop the engine, remove the key, and wait for all moving parts to stop before leaving the operating position.
3. Remove the wing nut securing the battery clamp (Figure 46).

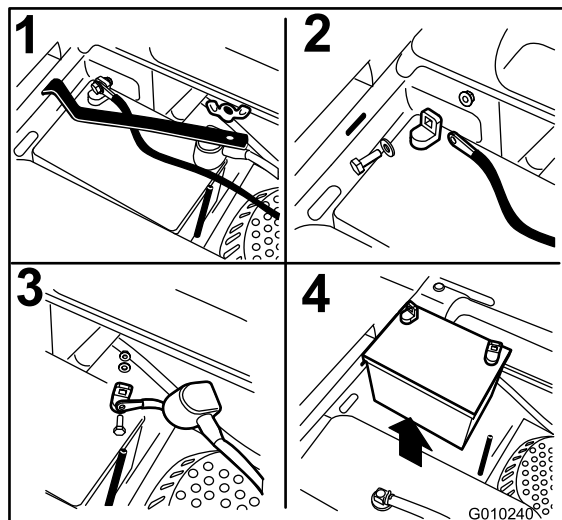

Figure 46

1. Remove the wing nut and
 2. Remove the negative battery cable (black) before the positive
 3. Remove the positive battery cable (red)
 4. Remove battery
-
4. Remove the clamp (Figure 46).
 5. First disconnect the negative battery cable (black) from the negative (-)(black) battery terminal (Figure 46).
 6. Slide the red terminal boot off the positive (red) battery terminal and remove the positive (+)(red) battery cable (Figure 46).
 7. Remove the battery.

Installing the Battery

1. Position battery in the tray with the terminal posts opposite from the fuel tank (Figure 46).
2. Install the positive (red) battery cable to positive (+) battery terminal.
3. Install the negative (black) battery cable to the negative (-) battery terminal.
4. Secure the cables with 2 bolts, 2 washers, and 2 locknuts (Figure 46).
5. Slide the red terminal boot onto the positive (red) battery post.
6. Install the clamp and secure it with the wing nut (Figure 46).

Charging the Battery

⚠ WARNING

Charging the battery produces gasses that can explode.

Never smoke near the battery, and keep sparks and flames away from battery.

Important: Always keep the battery fully charged. This is especially important to prevent battery damage when the temperature is below 0°C (32°F).

1. Charge the battery for 10 to 15 minutes at 25 to 30 amps or 30 minutes at 10 amps.
2. When the battery is fully charged, unplug the charger from the electrical outlet, then disconnect the charger leads from the battery posts (Figure 47).
3. Install the battery in the machine and connect the battery cables, refer to Installing the Battery.

Note: Do not run the machine with the battery disconnected; electrical damage may occur.

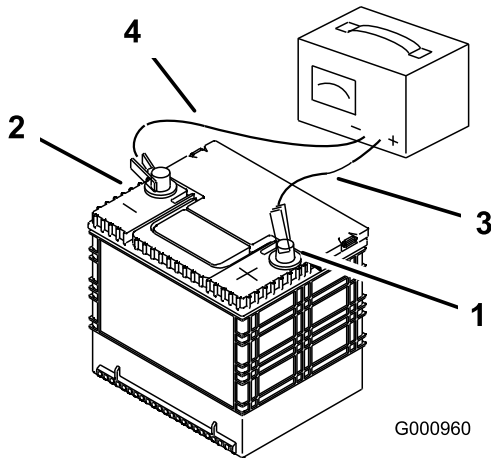

Figure 47

1. Positive battery post
2. Negative battery post
3. Red (+) charger lead
4. Black (-) charger lead

3. Install a new fuse having the same amperage as the fuse that you removed (Figure 48).

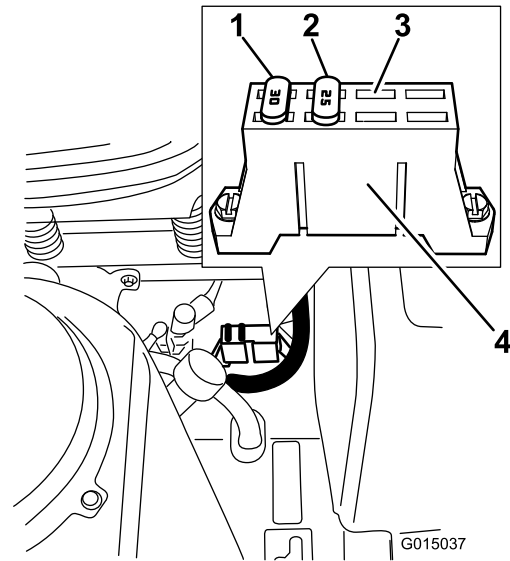

Figure 48

1. 30 amp
2. 25 amp
3. Open accessory slot
4. Fuse block

Servicing the Fuses

The electrical system is protected by fuses. It requires no maintenance; however if a fuse blows, check the component/circuit for a malfunction or short.

Fuses:

- Main, 30 amp, blade-type
 - Engine, 20 amp, blade-type
1. The fuses are located on right hand console next to the seat (Figure 48).
 2. To replace the fuses, pull out the fuse to remove it.

Drive System Maintenance

Checking the Tire Pressure

Service Interval: Every 25 hours—Check tire pressure.

Maintain the air pressure in the front and rear tires as specified. Uneven tire pressure can cause uneven cut. Check the pressure at the valve stem (Figure 49). Check the tires when they are cold to get the most accurate pressure reading.

Refer to the maximum pressure suggested by the tire manufacturer on the sidewall of the caster wheel tires.

Inflate the rear drive wheel tires to 13 psi.

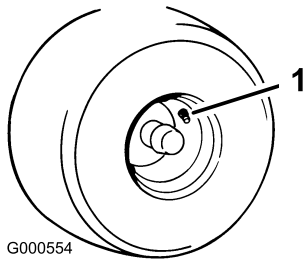

Figure 49

1. Valve stem

Hydraulic System Maintenance

Oil Type: 20w-50 engine oil.

System Capacity: approximately 4.495 liter (152 oz) with a filter change.

Important: Use oil specified or equivalent. Other fluids could cause system damage.

Checking the Hydraulic Oil Level

Service Interval: Every 25 hours

Check expansion reservoir and if necessary add 20W-50 engine oil to the FULL COLD line

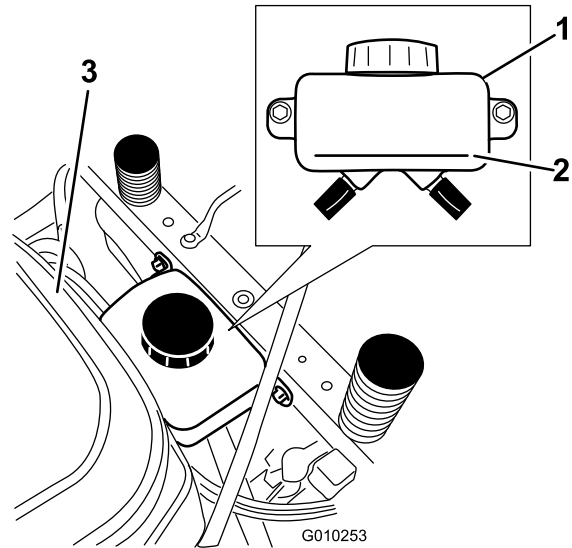

Figure 50

1. Expansion reservoir
2. Full Cold line
3. Engine

Changing the Hydraulic System Filter and Oil

The filter and oil are changed at the same time. **Do not** reuse oil. Once the new filter is installed and oil is added any air in the system must be purged.

The bleeding process is repeated until the oil remains at the FULL COLD line in the reservoir after purging. **Failure to properly perform this procedure can result in irreparable damage to the transaxle drive system.**

Removing Hydraulic System Filters

1. Stop engine, wait for all moving parts to stop, and allow engine to cool.
2. Remove the key and engage the parking brake.
3. Locate the filter and guards on each transaxle drive system (Figure 51).
4. Remove three screws securing the filter guard and guard.

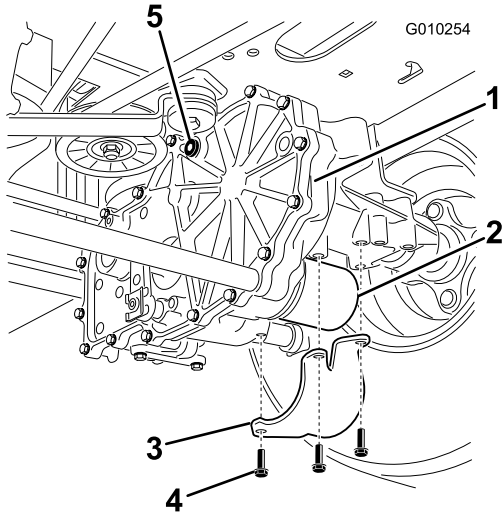

Figure 51
Right side shown

- | | |
|--------------------|--------------|
| 1. Transaxle drive | 4. Screws |
| 2. Oil filter | 5. Vent plug |
| 3. Filter guard | |

5. Carefully clean area around filters.

Note: It is important that no dirt or contamination enter hydraulic system.

6. Place a container below the filter to catch the oil that drains when the filter and vent plugs are removed.
7. Locate and remove the vent plug on each transmission
8. Unscrew the filter to remove and allow oil to drain from drive system.

Repeat this procedure for both filters.

Installing the Hydraulic System Filters

Service Interval: After the first 50 hours
Every 400 hours

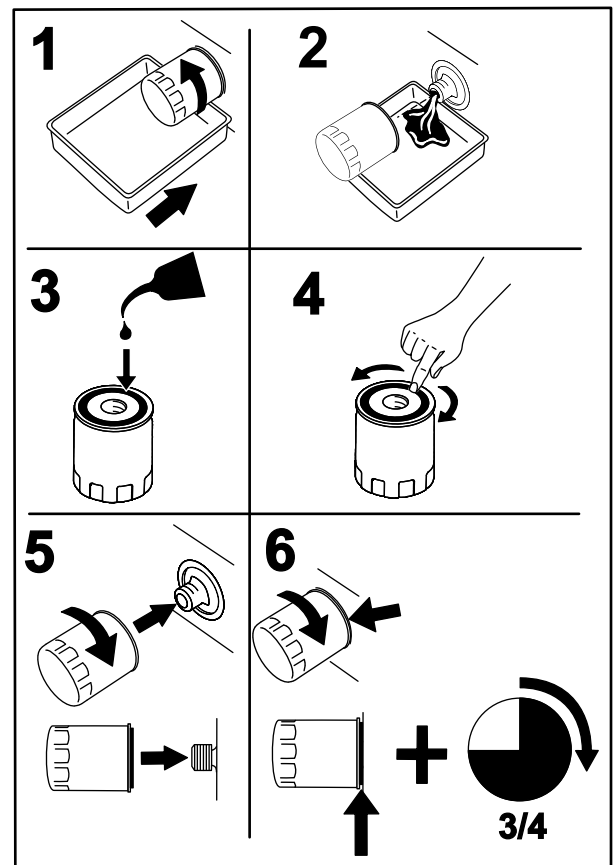

Figure 52

1. Apply a thin coat of oil on the surface of the rubber seal of each filter.
2. Turn the filter clockwise until rubber seal contacts the filter adapter then tighten the filter an additional 3/4 to 1 full turn.
3. Repeat for the other filter
4. Install the filter guards over each filter as previously removed. Use the three screws to secure the filter guards.
5. Verify the vent plugs are removed before adding the oil.
6. Slowly pour the specified oil through expansion reservoir until oil comes out of **one** of the vent plug holes.
7. Install the vent plug. Torque the plug to 180 in-lb (20.3 N-m).
8. Continue to add oil through the expansion reservoir until oil comes out of the remaining vent plug hole on the second transmission.
9. Install the vent plug. Torque the plug to 180 in-lb (20.3 N-m).
10. Continue to add oil through the expansion reservoir until it reaches the FULL COLD line on the expansion reservoir. Proceed to the Bleeding the Hydraulic System section.

Important: Failure to perform the *Bleeding the Hydraulic System* procedure after changing hydraulic filters and oil may result in irreparable damage to the transaxle drive system.

Bleeding the Hydraulic System

1. Raise the rear of machine up and support with jack stands (or equivalent support) just high enough to allow drive wheels to turn freely.

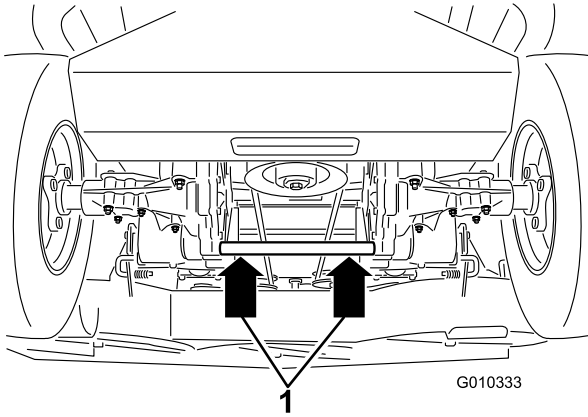

Figure 53

1. Jacking points

2. Go to the operator's position. Start the engine and move throttle control ahead to 1/2 throttle position. Disengage parking brake.
 - A. Move the bypass levers into the pushing the machine position; refer to the Pushing the Machine by Hand section in Operation. With the bypass valves open and the engine running, slowly move the motion control levers in both forward and reverse (5 or 6 times).
 - B. Move the bypass levers into the operating the machine position. With the bypass valve closed and the engine running, slowly move the directional control in both forward and reverse directions (5 to 6 times).
 - C. Stop the engine and check the oil level in the expansion reservoir. Add the specified oil as until it reaches the FULL COLD line on the expansion reservoir.
3. Repeat step 2 until all the air is completely purged from the system.

Note: When the transaxle operates at normal noise levels and moves smoothly forward and reverse at normal speeds, then the transaxle is considered purged.

4. Check the oil level in the expansion reservoir one last time. Add the specified oil as until it reaches the FULL COLD line on the expansion reservoir if necessary.

Mower Deck Maintenance

Servicing the Cutting Blades

Maintain sharp blades throughout the cutting season because sharp blades cut cleanly without tearing or shredding the grass blades. Tearing and shredding turns grass brown at the edges, which slows growth and increases the chance of disease.

Check the cutter blades daily for sharpness, and for any wear or damage. File down any nicks and sharpen the blades as necessary. If a blade is damaged or worn, replace it immediately with a genuine Toro replacement blade. For convenient sharpening and replacement, you may want to keep extra blades on hand.

⚠ WARNING

A worn or damaged blade can break, and a piece of the blade could be thrown into the operator's or bystander's area, resulting in serious personal injury or death.

- Inspect the blade periodically for wear or damage.
- Replace a worn or damaged blade.

Before Inspecting or Servicing the Blades

1. Park the machine on a level surface, disengage the blade control switch (PTO), and set the parking brake.
2. Turn the ignition key to Off. Remove the key.

Inspecting the Blades

Service Interval: Before each use or daily

1. Inspect the cutting edges (Figure 54).

Note: If the edges are not sharp or have nicks, remove and sharpen the blades. Refer to [Sharpening the Blades \(page 45\)](#).

2. Inspect the blades, especially the curved area (Figure 54).

Note: If you notice any damage, wear, or a slot forming in this area (Figure 54), immediately install a new blade.

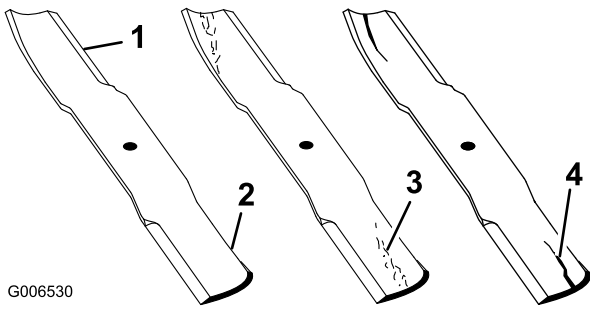

Figure 54

- | | |
|-----------------|----------------------|
| 1. Cutting Edge | 3. Wear/slot Forming |
| 2. Curved Area | 4. Crack |

Checking for Bent Blades

Note: The machine must be on a level surface for the following procedure.

1. Raise the mower deck to the highest height-of-cut position; also considered the 'transport' position.
2. While wearing thickly padded gloves or other adequate hand protection slowly rotate blade to be measured into a position that allows effective measurement of the distance between the cutting edge and the level surface the machine is on.

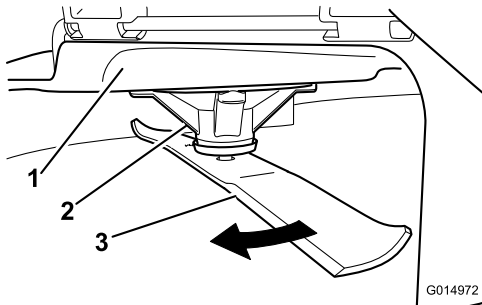

Figure 55

- | | |
|--------------------|----------|
| 1. Deck | 3. Blade |
| 2. Spindle housing | |

3. Measure from the tip of the blade to the flat surface here.

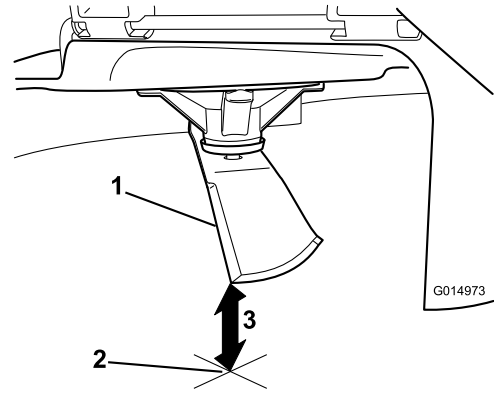

Figure 56

1. Blade, in position for measuring
2. Level surface
3. Measured distance between blade and surface (A)

4. Rotate the same blade 180 degrees so that the opposing cutting edge is now in the same position.

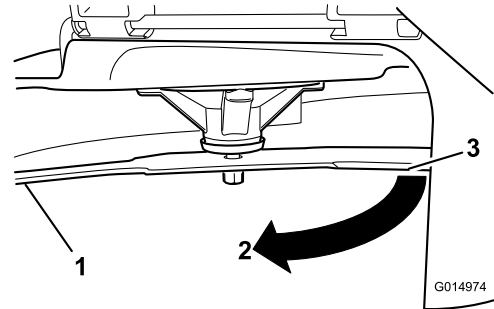

Figure 57

1. Blade, side previously measured
2. Measurement position used previously
3. Opposing side of blade being moved into measurement position

5. Measure from the tip of the blade to the flat surface here. The variance should be no more than 1/8 inch (3mm).

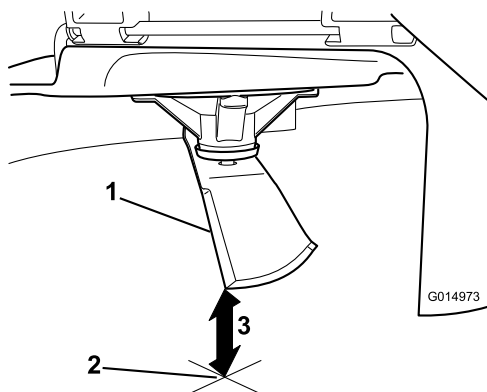

Figure 58

1. Opposing blade edge, in position for measuring
2. Level surface
3. Second measured distance between blade and surface (B)

⚠ WARNING

A blade that is bent or damaged could break apart and could seriously injure or kill you or bystanders.

- Always replace a bent or damaged blade with a new blade.
 - Never file or create sharp notches in the edges or surfaces of the blade.
- A. If the difference between A and B is greater than 1/8 inch (3mm) replace the blade with a new blade. Refer to [Removing the Blades \(page 45\)](#) and [Installing the Blades \(page 46\)](#).

Note: If a bent blade is replaced with a new one and the dimension obtained continues to exceed 1/8 inch (3mm), the blade spindle could be bent. Contact an Authorized Toro Dealer for service.
 - B. If the variance is within constraints, move to the next blade..
6. Repeat this procedure on each blade.

Removing the Blades

Blades must be replaced if a solid object is hit, if the blade is out of balance or is bent. To ensure optimum performance and continued safety conformance of the machine, use genuine Toro replacement blades. Replacement blades made by other manufacturers may result in non-conformance with safety standards.

Hold the blade end using a rag or thickly-padded glove. Remove the blade bolt (rotating it counter-clockwise), curved washer, and blade from the spindle shaft ([Figure 59](#)).

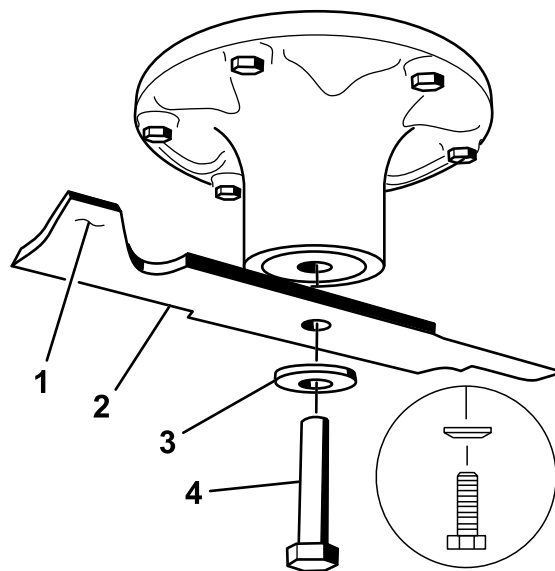

Figure 59

1. Sail Area of Blade
2. Blade
3. Curved washer
4. Blade Bolt

Sharpening the Blades

⚠ WARNING

When sharpening blade, pieces of blade could be thrown and cause serious injury.

Wear proper eye protection when sharpening blade.

1. Use a file to sharpen the cutting edge at both ends of the blade ([Figure 60](#)).

Note: Maintain the original angle. The blade retains its balance if the same amount of material is removed from both cutting edges.

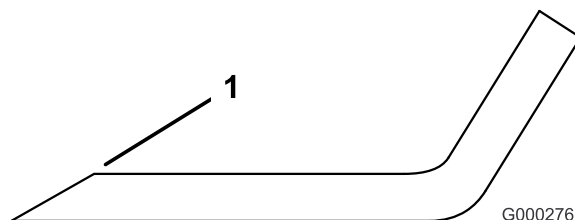

Figure 60

1. Sharpen at original angle
2. Check the balance of the blade by putting it on a blade balancer ([Figure 61](#)).

Note: If the blade stays in a horizontal position, the blade is balanced and can be used. If the blade is not balanced, file some metal off the end of the sail area only ([Figure 59](#)). Repeat this procedure until the blade is balanced.

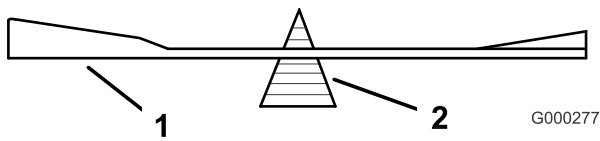

Figure 61

1. Blade
2. Balancer

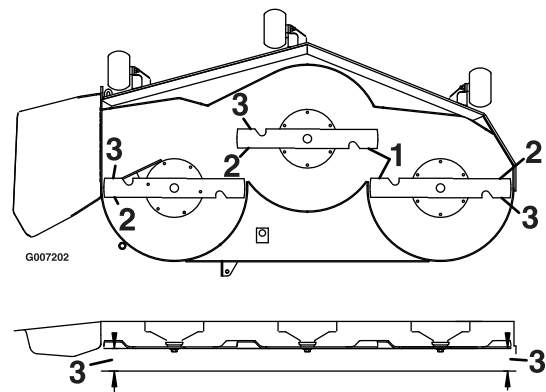

Figure 62

1. Blades side to side
2. Outside cutting edges
3. Measure from the tip of the blade to the flat surface here

Installing the Blades

1. Install the blade onto the spindle shaft (Figure 59).

Important: The curved part of the blade must be pointing upward toward the inside of the mower to ensure proper cutting.

2. Install the spring disk and blade bolt (rotating it clockwise).

Note: The spring disk cone must be installed toward the bolt head (Figure 59).

3. Torque the blade bolt to 135-150 N-m (100-110 ft-lb).

Mower Deck Leveling

Check to ensure the mower deck is level any time you install the mower or when you see an uneven cut on your lawn.

The mower deck must be checked for bent blades prior to leveling; any bent blades must be removed and replaced. Refer to the, [Checking for Bent Blades \(page 44\)](#), procedure before continuing.

The mower deck must be leveled side-to-side first then the front to rear slope can be adjusted.

Requirements:

- The machine must be on a level surface.
- All four tires must be properly inflated. Refer to [Checking the Tire Pressure \(page 41\)](#).

Checking Side-to-Side Level

The mower blades must be level from side to side. Check the side-to-side level any time you install the mower or when you see an uneven cut on your lawn.

1. Park the machine on a level surface and disengage the blade control switch.
2. Move the motion control levers outward to the neutral lock position, stop the engine, remove the key, set the parking brake and wait for all moving parts to stop before leaving the operating position.
3. Carefully rotate the blades side to side.
4. Measure between the outside cutting edges and the flat surface (Figure 62).

Note: If both measurements are not within 5 mm (3/16 inch), an adjustment is required; continue to the Leveling procedure.

Checking the Front-to-Rear Blade Slope

Check the front-to-rear blade level any time you install the mower. If the front of the mower is more than 7.9 mm (5/16 inch) lower than the rear of the mower, adjust the blade level using the following instructions:

1. Park the machine on a level surface and disengage the blade control switch.
2. Move the motion control levers outward to the neutral position, engage the parking brake, stop the engine, remove the key, and wait for all moving parts to stop before leaving the operating position.
3. Carefully rotate the blades so they are facing front to rear (Figure 63).
4. Measure from the tip of the front blade to the flat surface and the tip of the rear blade to the flat surface (Figure 63).

Note: If the front blade tip is not 1.6-7.9 mm (1/16-5/16 inch) lower than the rear blade tip, continue to the Leveling the Mower Deck procedure.

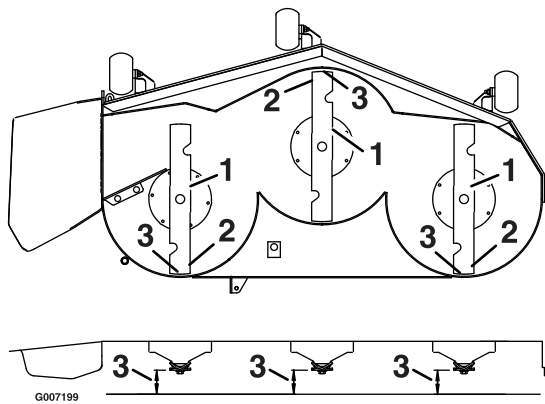

Figure 63

1. Blades front to rear
2. Outside cutting edges
3. Measure from the tip of the blade to the flat surface here

Leveling the Mower Deck

1. Set anti-scalp rollers to top holes or remove completely for this procedure.
2. Set the height-of-cut lever to the 76 mm (3 inch) position.
3. Place two 6.66 cm (2-5/8 inch) blocks under each side of the front edge of the deck, but not under the anti-scalp roller brackets.
4. Place two 7.30 cm (2-7/8 inch) thick blocks under the rear edge of the cutting deck skirt; one on each side of the cutting deck.

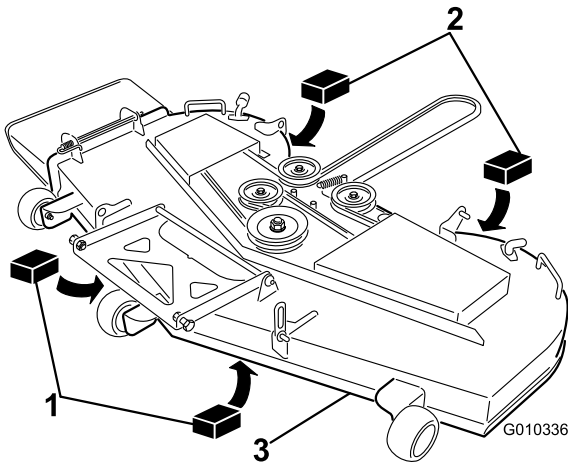

Figure 64

1. Wood block, 2-5/8 inch (6.66 cm) thick
 2. Wood block, 2-7/8 inch (7.30 cm) thick
 3. Front edge
5. Loosen the leveling adjust locking nuts (item 3) on all four corners so that the deck is sitting securely on all four blocks.

Note: Make sure that the deck hangers are all the way down (at the top of the slot) and the deck lift foot lever is pushed back against the stop (Figure 65).

6. Tighten the four leveling adjust locking nuts (Figure 65).

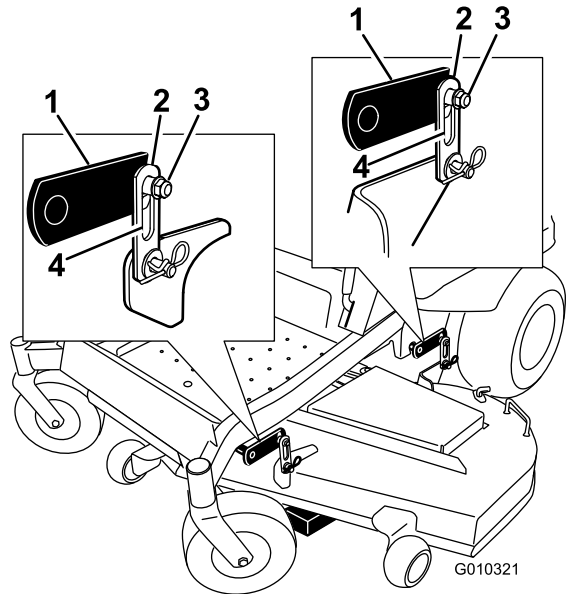

Figure 65

1. Deck lift arm
2. Deck hanger
3. Leveling adjust locking nut
4. Slot in deck hanger

7. Check that the blocks fit just snugly under the deck skirt. Make sure all attachment bolts are tight
8. Verify the deck is level by checking the side-to-side level and front-to-rear blade slope; repeat the deck leveling procedure if necessary.

Inspecting the Belts

Service Interval: Every 50 hours

Check the belts for squealing when the belt is rotating, blades slipping when cutting grass, frayed belt edges, burn marks and cracks are signs of a worn mower belt. Replace the mower belt if any of these conditions is evident.

Replacing the Mower Belt

Squealing when the belt is rotating, blades slipping when cutting grass, frayed belt edges, burn marks and cracks are signs of a worn mower belt. Replace the mower belt if any of these conditions is evident.

⚠ WARNING

The spring is under tension when installed and can cause personal injury.

Be careful when removing the belt.

Removing the Mower Belt

Squealing when the belt is rotating, blades slipping when cutting grass, frayed belt edges, burn marks and cracks are signs of a worn mower belt. Replace the mower belt if any of these conditions is evident.

1. Disengage the blade control switch (PTO), move the motion control levers to the neutral locked position and set the parking brake.
2. Stop the engine, remove the key, and wait for all moving parts to stop before leaving the operating position.
3. Lower the mower to the 3 inch (76 mm) height-of-cut position.
4. Remove the belt covers (Figure 66).

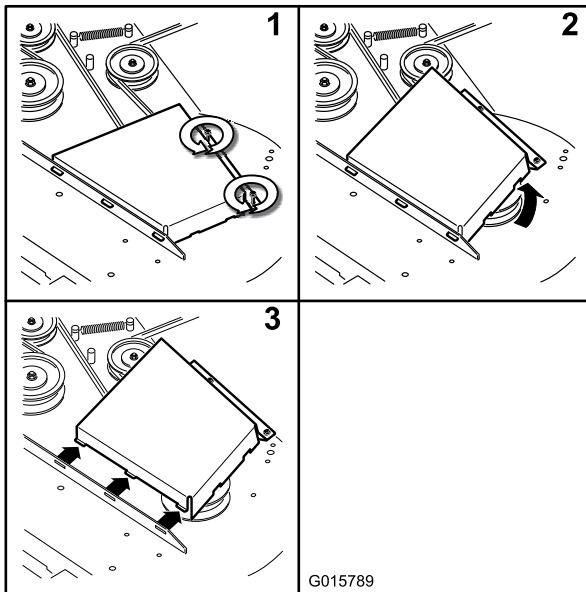

Figure 66

1. Loosen the screws
2. Pivot the belt cover up
3. Remove belt cover

5. Using a spring removal tool (Toro part no. 92-5771), remove the idler spring from the deck post to remove tension on the idler pulley (Figure 67).

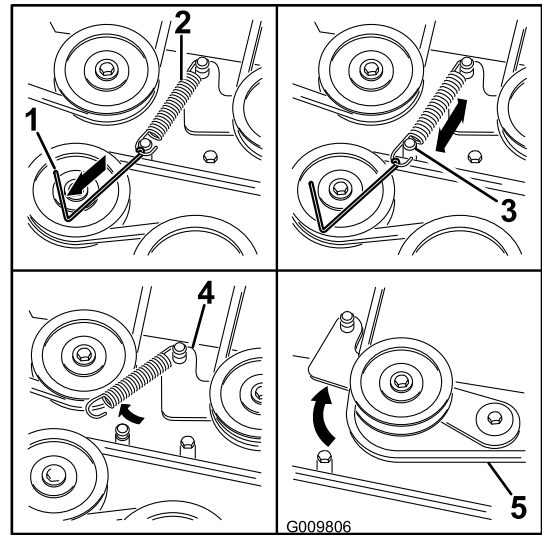

Figure 67

1. Spring removal tool (Toro part no. 92-5771)
2. Idler spring
3. Deck post
4. Idler arm
5. Mower belt

6. Lower the mower to the lowest height-of-cut.
7. Place the height-of-cut pin in the lock position for lowest height-of-cut.
8. Remove the belt from the mower deck pulleys and remove the existing belt.

Installing the Mower Belt

1. Install the new belt around the mower pulleys and the clutch pulley under the engine (Figure 67).
2. Using a spring removal tool (Toro part no. 92-5771), install the idler spring over the deck post and place tension on the idler pulley and mower belt (Figure 67).
3. Ensure that the belt is properly seated in all pulleys.
4. Install the belt covers (Figure 68).

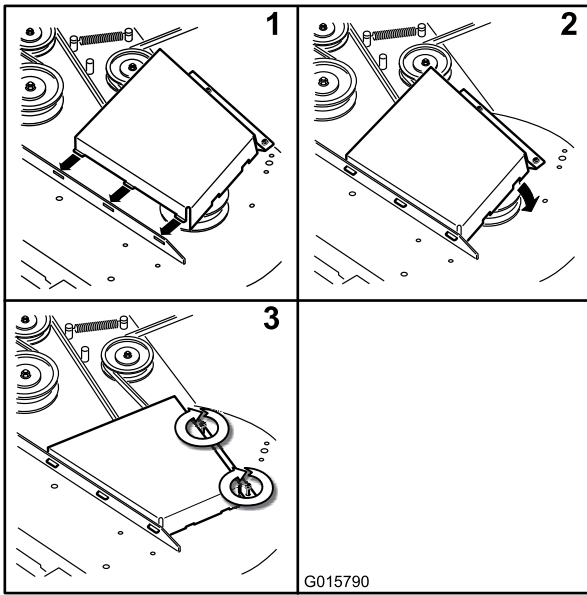

Figure 68

1. Position the belt cover and ensure the tabs seat
2. Pivot the belt cover down
3. Tighten the screws

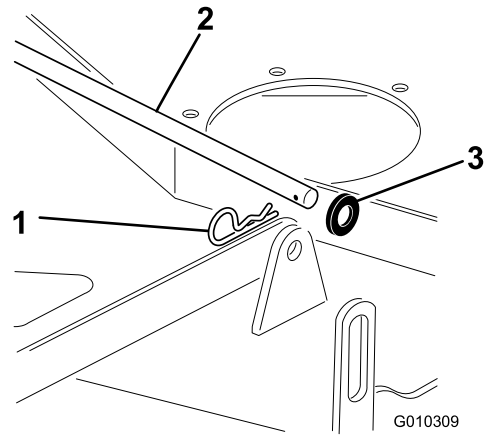

Figure 69

1. Hair pin cotter
2. Link bar
3. Washer

Removing the Mower

Park the machine on a level surface and disengage the blade control switch. Move the motion control levers outward to the neutral position, engage parking brake, stop the engine, remove the key, and wait for all moving parts to stop before leaving the operating position.

Lower the mower to the 3 inch (76 mm) height-of-cut position. Remove the mower belt from the engine pulley; refer to the Replacing the Mower Belt procedure. Lower the mower to the lowest height-of-cut. Select one of the following procedures depending on the mower deck size installed to complete the removal.

1. Remove the hair pin cotter and washer securing the long, link bar to the frame and deck; remove the link bar (Figure 69).

2. Remove the hardware from the front and rear deck hangers on both sides of the deck (Figure 70).

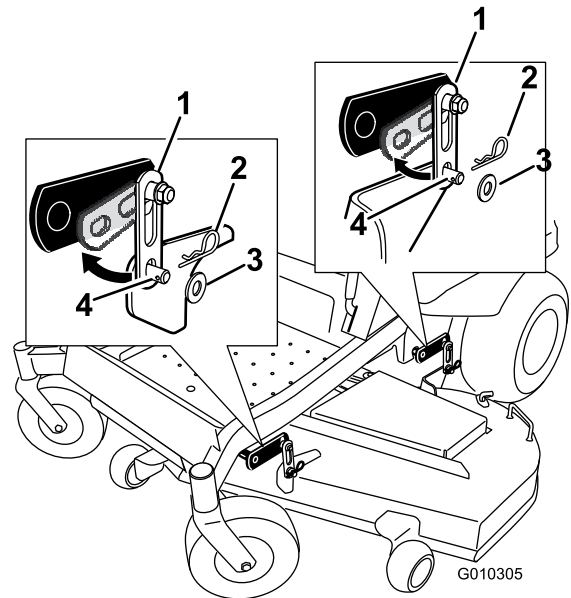

Figure 70

1. Deck hanger
2. Hairpin cotter
3. Washer
4. Welded post on deck

3. Raise the height-of-cut to the transport position.
4. Slide the mower out from underneath the machine.

Note: Retain all parts for future installation.

Installing the Mower

1. Park the machine on a level surface and disengage the blade control switch.
2. Move the motion control levers outward to the neutral lock position, stop the engine, remove the key, set the parking brake and wait for all moving parts to stop before leaving the operating position.
3. Slide the mower under the machine.
4. Lower the height-of-cut lever to the lowest position.
5. Place the height-of-cut pin in the lock position for lowest height-of-cut.
6. Lift the rear of the mower deck and attach the rear support on the mower deck to the rear deck hangers. Secure them with a washer and hairpin cotter (Figure 70).
7. Attach the front support on the mower deck to the front deck hangers, and secure them with a washer and hairpin cotter (Figure 70).
8. Install the long, link bar through the frame hanger and deck. Secure the link bar with the hair pin cotters and washers removed previously (Figure 69).
9. Install the mower belt onto the engine pulley; refer to [Replacing the Mower Belt \(page 47\)](#).

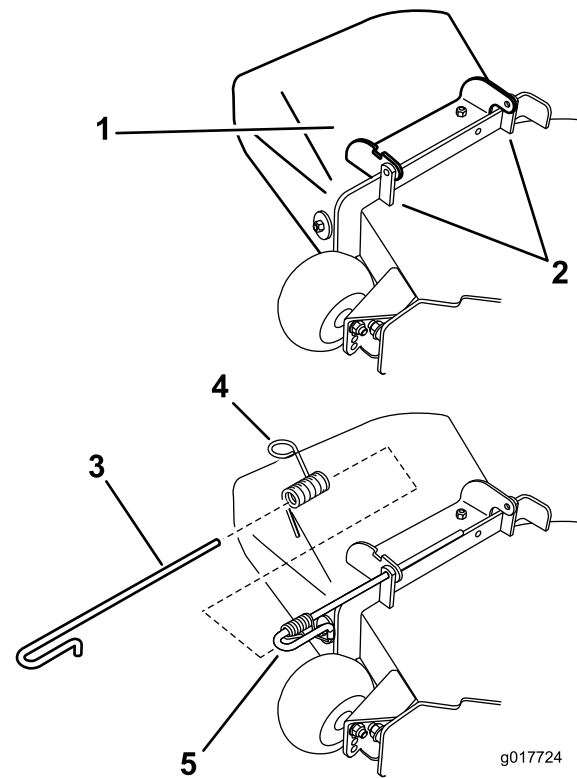

Figure 71

- | | |
|-----------------------|----------------------------------|
| 1. Deflector assembly | 4. Spring |
| 2. Deck brackets | 5. Spring installed over the rod |
| 3. Rod | |

Replacing the Grass Deflector

Service Interval: Before each use or daily—Inspect the grass deflector for damage

⚠ WARNING

An uncovered discharge opening could allow the lawn mower to throw objects in the operator's or bystander's direction and result in serious injury. Also, contact with the blade could occur.

Never operate the lawn mower unless you install a mulch plate, discharge deflector, or grass collection system.

Inspect the grass deflector for damage before each use. Replace any damaged parts before use.

1. Disengage the spring from the notch in the deflector bracket and slide the rod out of the welded deck brackets, spring, and discharge deflector (Figure 71).
2. Remove the damaged or worn discharge deflector.

3. Position the new discharge deflector assembly with the bracket ends between the welded brackets on the deck as shown in Figure 71.
4. Install the spring onto the straight end of the rod. Position the spring on the rod as shown in so the shorter spring end is coming from under the rod before the bend and going over the rod as it returns from the bend.
5. Lift the loop end of the spring and place it into the notch on the deflector assembly bracket (Figure 72).

Cleaning

Washing the Underside of the Mower

Service Interval: After each use—Clean the mower housing.

Wash the underside of the mower after each use to prevent grass buildup for improved mulch action and clipping dispersal.

1. Park the machine on a level surface and disengage the blade control switch.
2. Move the motion control levers outward to the neutral lock position, stop the engine, remove the key, and wait for all moving parts to stop before leaving the operating position.
3. Attach the hose coupling to the end of the mower washout fitting, and turn the water on high (Figure 73).

Note: Spread petroleum jelly on the washout fitting O-ring to make the coupling slide on easier and protect the O-ring.

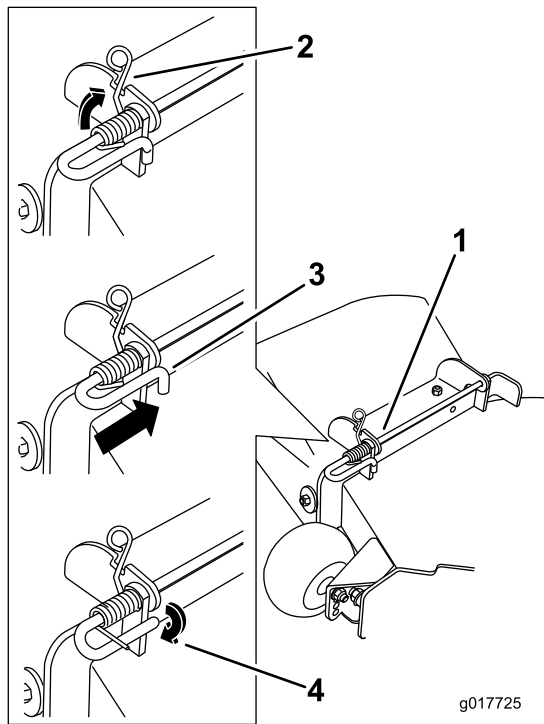

Figure 72

1. Rod and spring assembly partially installed
2. Loop end of the spring installed into the notch in the deflector bracket
3. Rod, short end, moved behind mower bracket
4. Short end, retained by mower bracket.

6. Secure the rod and spring assembly by twisting it so the short end of the rod can be placed behind the front bracket welded to the deck (Figure 72).

Important: The grass deflector must be spring loaded in the down position. Lift the deflector up to test that it snaps to the full down position.

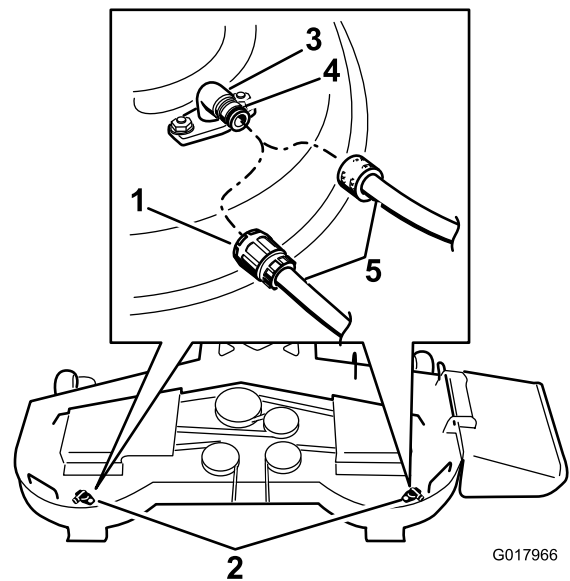

Figure 73

1. Coupling
2. Washout fitting locations
3. Washout fitting
4. O-ring
5. Hose

4. Lower the mower to the lowest height-of-cut.
5. Sit on the seat and start the engine. Engage the blade control switch and let the mower run for one to three minutes.
6. Disengage the blade control switch, stop the engine, and remove the ignition key. Wait for all moving parts to stop.
7. Turn the water off and remove the coupling from the washout fitting.

Note: If the mower is not clean after one washing, soak it and let it stand for 30 minutes. Then repeat the process.

8. Run the mower again for 1 to 3 minutes to remove excess water.

⚠ WARNING

A broken or missing washout fitting could expose you and others to thrown objects or blade contact. Contact with blade or thrown debris can cause injury or death.

- Replace broken or missing washout fitting immediately, before using mower again.
- Never put your hands or feet under the mower or through openings in the mower.

Waste Disposal

Engine oil, batteries, hydraulic oil, and engine coolant are pollutants to the environment. Dispose of these according to your state and local regulations.

Storage

Cleaning and Storage

1. Disengage the blade control switch (PTO), set the parking brake, and turn the ignition key to Off. Remove the key.
2. Remove grass clippings, dirt, and grime from the external parts of the entire machine, especially the engine and hydraulic system. Clean dirt and chaff from the outside of the engine cylinder head fins and blower housing.

Important: You can wash the machine with mild detergent and water. Do not pressure wash the machine. Avoid excessive use of water, especially near the control panel, engine, hydraulic pumps, and motors.

3. Check the brake; refer to [Operating the Parking Brake \(page 20\)](#).
4. Service the air cleaner; refer to [Servicing the Air Cleaner \(page 34\)](#).
5. Grease the machine; refer to [Lubrication \(page 33\)](#).
6. Change the crankcase oil; refer to [Servicing the Engine Oil \(page 34\)](#).
7. Check the tire pressure; refer to [Checking the Tire Pressure \(page 41\)](#)
8. Change the hydraulic filter; refer to [Hydraulic System Maintenance \(page 41\)](#)
9. Charge the battery; refer to [Charging the Battery \(page 40\)](#)
10. Scrape any heavy buildup of grass and dirt from the underside of the mower, then wash the mower with a garden hose.

Note: Run the machine with the blade control switch (PTO) engaged and the engine at high idle for 2 to 5 minutes after washing.

11. Check the condition of the blades; refer to [Servicing the Cutting Blades \(page 43\)](#)
12. Prepare the machine for storage when non-use occurs over 30 days. Prepare the machine for storage as follows:
 - A. Add a petroleum based stabilizer/conditioner to fuel in the tank. Follow mixing instructions from the stabilizer manufacturer. Do not use an alcohol based stabilizer (ethanol or methanol).

Note: A fuel stabilizer/conditioner is most effective when mixed with fresh fuel and used at all times.

- B. Run the engine to distribute conditioned fuel through the fuel system (5 minutes).
- C. Stop the engine, allow it to cool, and drain the fuel tank.

- D. Restart the engine and run it until it stops.
- E. Dispose of fuel properly. Recycle as per local codes.

Important: Do not store stabilizer/conditioned fuel over 90 days.

- 13. Check and tighten all bolts, nuts, and screws. Repair or replace any part that is damaged.
- 14. Paint all scratched or bare metal surfaces. Paint is available from your Authorized Service Dealer.
- 15. Store the machine in a clean, dry garage or storage area. Remove the key from the ignition switch and keep it out of reach of children or other unauthorized users. Cover the machine to protect it and keep it clean.

Troubleshooting

Problem	Possible Cause	Corrective Action
The starter does not crank.	<ol style="list-style-type: none"> 1. Blade control switch (PTO) is engaged. 2. Parking brake is not on. 3. Drive levers are not in neutral lock position. 4. Operator is not seated. 5. Battery is dead. 6. Electrical connections are corroded or loose. 7. Fuse is blown. 8. Relay or switch is defective. 	<ol style="list-style-type: none"> 1. Move blade control switch (PTO) to disengaged. 2. Set the parking brake. 3. Ensure the drive levers are in the neutral lock position. 4. Sit on the seat. 5. Charge the battery. 6. Check the electrical connections for good contact. 7. Replace fuse. 8. Contact an Authorized Service Dealer.
The engine will not start, starts hard, or fails to keep running.	<ol style="list-style-type: none"> 1. Fuel tank is empty. 2. Fuel shutoff valve is closed. 3. Oil level in the crankcase is low. 4. The throttle and choke are not in the correct position. 5. Dirt in fuel filter. 6. Dirt, water, or stale fuel is in the fuel system. 7. Air cleaner is dirty. 8. Seat switch is not functioning properly. 9. Electrical connections are corroded, loose or faulty. 10. Relay or switch is defective. 11. Faulty spark plug. 12. Spark plug wire is not connected. 	<ol style="list-style-type: none"> 1. Fill the fuel tank. 2. Open the fuel shutoff valve. 3. Add oil to the crankcase. 4. Be sure the throttle control is midway between the "SLOW" and "FAST" positions, and the choke is in the "ON" position for a cold engine or the "OFF" position for a warm engine. 5. Replace the fuel filter. 6. Contact an Authorized Service Dealer. 7. Clean or replace the air cleaner element. 8. Check the seat switch indicator. Replace seat if needed. 9. Check the electrical connections for good contact. Clean connector terminals thoroughly with electrical contact cleaner, apply dielectric grease and reconnect. 10. Contact an Authorized Service Dealer. 11. Clean, adjust or replace spark plug. 12. Check the spark plug wire connection.
The engine loses power.	<ol style="list-style-type: none"> 1. Engine load is excessive. 2. Air cleaner is dirty. 3. Oil level in the crankcase is low. 4. Cooling fins and air passages above the engine are plugged. 5. Vent hole in the fuel cap is plugged. 6. Dirt in the fuel filter. 7. Dirt, water, or stale fuel is in the fuel system. 	<ol style="list-style-type: none"> 1. Reduce the ground speed. 2. Clean the air cleaner element. 3. Add oil to the crankcase. 4. Remove the obstruction from the cooling fins and air passages. 5. Clean or replace the fuel cap. 6. Replace the fuel filter. 7. Contact an Authorized Service Dealer.
The engine overheats.	<ol style="list-style-type: none"> 1. Engine load is excessive. 2. Oil level in the crankcase is low. 3. Cooling fins and air passages above the engine are plugged. 	<ol style="list-style-type: none"> 1. Reduce the ground speed. 2. Add oil to the crankcase. 3. Remove the obstruction from the cooling fins and air passages.
The mower pulls left or right (with levers fully forward).	<ol style="list-style-type: none"> 1. Tracking needs adjustment 2. Tire pressure in drive tires not correct. 	<ol style="list-style-type: none"> 1. Adjust the tracking. 2. Adjust tire pressure in the drive tires.

Problem	Possible Cause	Corrective Action
The machine does not drive.	<ol style="list-style-type: none"> 1. By pass valves is not closed tight. 2. Pump belt is worn, loose or broken. 3. Pump belt is off a pulley. 4. Broken or missing idler spring. 5. Hydraulic oil level is low or too hot. 	<ol style="list-style-type: none"> 1. Tighten the by pass valves. 2. Change the belt. 3. Change the belt. 4. Replace the spring. 5. Add hydraulic oil to reservoirs or let it cool down.
The machine vibrates abnormally.	<ol style="list-style-type: none"> 1. Cutting blade(s) is/are bent or unbalanced. 2. Blade mounting bolt is loose. 3. Engine mounting bolts are loose. 4. Loose engine pulley, idler pulley, or blade pulley. 5. Engine pulley is damaged. 6. Blade spindle is bent. 7. Motor mount is loose or worn. 	<ol style="list-style-type: none"> 1. Install new cutting blade(s). 2. Tighten the blade mounting bolt. 3. Tighten the engine mounting bolts. 4. Tighten the appropriate pulley. 5. Contact an Authorized Service Dealer. 6. Contact an Authorized Service Dealer. 7. Contact an Authorized Service Dealer.
The machine cutting height is uneven.	<ol style="list-style-type: none"> 1. Blade(s) not sharp. 2. Cutting blade(s) is/are bent. 3. Mower deck is not level. 4. Underside of mower is dirty. 5. Tire pressure is not correct. 6. Blade spindle bent. 	<ol style="list-style-type: none"> 1. Sharpen the blade(s). 2. Install new cutting blade(s). 3. Level mower deck from side-to-side and front-to-rear. 4. Clean the underside of the mower. 5. Adjust the tire pressure. 6. Contact an Authorized Service Dealer.
The blades do not rotate.	<ol style="list-style-type: none"> 1. Mower deck belt is worn, loose or broken. 2. Mower deck belt is off pulley. 3. Pump drive belt is worn, loose or broken. 4. Broken or missing idler spring. 	<ol style="list-style-type: none"> 1. Install new deck belt. 2. Install mower deck pulley and check the idler pulley, idler arm and spring for correct position and function. 3. Check the belt tension or install new belt. 4. Replace the spring.

Notes:

Notes:

Notes:



The Toro Total Coverage Warranty

Limited Warranty (see warranty periods below)

Conditions and Products Covered

The Toro Company and its affiliate, Toro Warranty Company, pursuant to an agreement between them, jointly promise to the original purchaser to repair the Toro Products listed below if defective in materials or workmanship.

The following time periods apply from the date of purchase by the original owner:

Products	Warranty Period
TimeCutter and MX Mowers • Engines ¹ — Residential use	Residential use ² — 3 years Kawasaki — 3 years Kohler — 3 years Toro — 3 years
TimeCutter and MX Mowers • Engines ¹ — Commercial use	Commercial use 30 days Kawasaki — 3 years Kohler — 90 days Toro — 90 days
TITAN Mowers — Residential or Commercial use • Engines ¹ — Residential or Commercial use • Frame	3 years or 240 hours ³ Kawasaki — 3 years Kohler — 2 years Lifetime (original owner only) ⁴
TITAN MX Mowers — Residential or Commercial use • Engines ¹ — Residential or Commercial use • Frame	3 years or 400 hours ³ Kawasaki — 3 years Kohler — 2 years Lifetime (original owner only) ⁴
All Mowers • Attachments • Battery	1 year 90 days Parts and Labor 1 year Parts only
• Belts and Tires	90 days

¹Some engines used on Toro Products are warranted by the engine manufacturer.

²Residential use means use of the product on the same lot as your home. Use at more than one location is considered commercial use and the commercial use warranty would apply.

³Whichever occurs first.

⁴Lifetime Frame Warranty - If the main frame, consisting of the parts welded together to form the tractor structure that other components such as the engine are secured to, cracks or breaks in normal use, it will be repaired or replaced, at Toro's option, under warranty at no cost for parts and labor. Frame failure due to misuse or abuse and failure or repair required due to rust or corrosion are not covered.

This warranty includes the cost of parts and labor, but you must pay transportation costs.

Warranty may be denied if the hour meter is disconnected, altered, or shows signs of being tampered with.

Owner Responsibilities

You must maintain your Toro Product by following the maintenance procedures described in the *Operator's Manual*. Such routine maintenance, whether performed by a dealer or by you, is at your expense.

Countries Other than the United States or Canada

Customers who have purchased Toro products outside the United States or Canada should contact their Toro Distributor (Dealer) to obtain guarantee policies for your country, province, or state. If for any reason you are dissatisfied with your Distributor's service or have difficulty obtaining guarantee information, contact the Toro importer. If all other remedies fail, you may contact us at Toro Warranty Company.

Australian Consumer Law: Australian customers will find details relating to the Australian Consumer Law either inside the box or at your local Toro Dealer.

Instructions for Obtaining Warranty Service

If you think that your Toro Product contains a defect in materials or workmanship, follow this procedure:

1. Contact any Authorized Toro Service Dealer to arrange service at their dealership. To locate a dealer convenient to you, refer to the *Yellow Pages* of your telephone directory (look under "Lawn Mowers") or access our web site at www.Toro.com. You may also call the numbers listed in item #3 to use the 24-hour Toro Dealer locator system.
2. Bring the product and your proof of purchase (sales receipt) to the Service Dealer. The dealer will diagnose the problem and determine if it is covered under warranty.
3. If for any reason you are dissatisfied with the Service Dealer's analysis or with the assistance provided, contact us at:

Customer Care Department, RLC Division
Toro Warranty Company
8111 Lyndale Avenue South
Bloomington, MN 55420-1196
Toll free at 866-216-6029 (U.S. customers)
Toll free at 866-216-6030 (Canadian customers)

Items and Conditions Not Covered

There is no other express warranty except for special emission system coverage and engine warranty coverage on some products. This express warranty does not cover the following:

- Cost of regular maintenance service or parts, such as filters, fuel, lubricants, oil changes, spark plugs, air filters, blade sharpening/worn blade on mowers, cable/linkage adjustments, or brake and clutch adjustments
- Components failing due to normal wear
- Any product or part which has been altered or misused and requires replacement or repair due to accidents or lack of proper maintenance
- Repairs necessary due to improper battery care, failure to use fresh fuel (less than one month old), or failure to properly prepare the unit prior to any period of non-use over one month
- Pickup and delivery charges
- Operational misuse, neglect, or accidents
- Repairs or attempted repairs by anyone other than an Authorized Toro Service Dealer

General Conditions

All repairs covered by these warranties must be performed by an Authorized Toro Service Dealer using Toro approved replacement parts.

Neither The Toro Company nor Toro Warranty Company is liable for indirect, incidental or consequential damages in connection with the use of the Toro Products covered by this warranty, including any cost or expense of providing substitute equipment or service during reasonable periods of malfunction or non-use pending completion of repairs under this warranty.

All implied warranties of merchantability (that the product is fit for ordinary use) and fitness for use (that the product is fit for a particular purpose) are limited to the duration of the express warranty.

Some states do not allow exclusions of incidental or consequential damages, or limitations on how long an implied warranty lasts, so the above exclusions and limitations may not apply to you.

This warranty gives you specific legal rights, and you may also have other rights which vary from state to state.