



Count on it.

Operator's Manual

**Greensmaster® eFlex™® 1800
and 2100 Traction Units and
Lithium Ion Battery Pack**

Model No. 04042—Serial No. 312000001 and Up

Model No. 04043—Serial No. 312000001 and Up

Model No. 04232—Serial No. 312000001 and Up

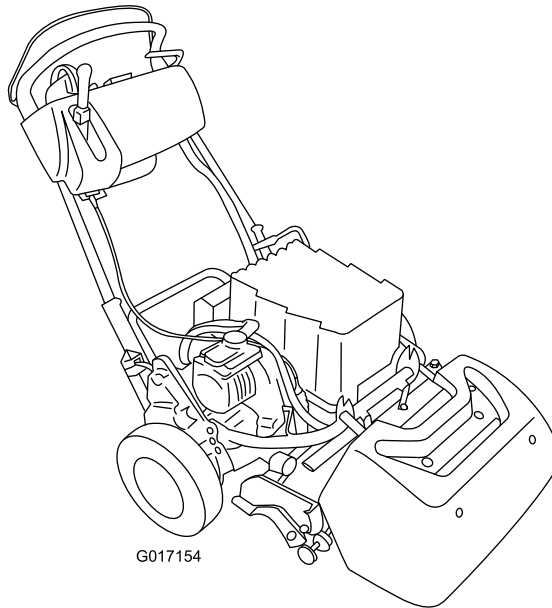

This product complies with all relevant European directives, for details please see the separate product specific Declaration of Conformity (DOC) sheet.

Model No. _____ Serial No. _____

Introduction

This machine is a walk-behind, reel-blade lawn mower intended to be used by professional, hired operators in commercial applications. It is primarily designed for cutting grass on well-maintained lawns in parks, golf courses, sports fields, and on commercial grounds. It is not designed for cutting brush, mowing grass and other growth alongside highways, or for agricultural uses.

Read this information carefully to learn how to operate and maintain your product properly and to avoid injury and product damage. You are responsible for operating the product properly and safely.

You may contact Toro directly at www.Toro.com for product and accessory information, help finding a dealer, or to register your product.

Whenever you need service, genuine Toro parts, or additional information, contact an Authorized Service Dealer or Toro Customer Service and have the model and serial numbers of your product ready. Figure 1 identifies the location of the model and serial numbers on the product. Write the numbers in the space provided.

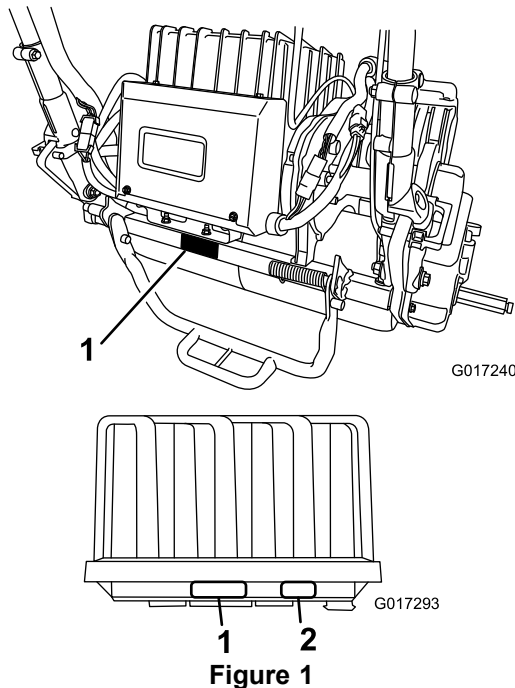

Figure 1

1. Location of the model and serial numbers
2. Battery pack manufacturer's information

This manual identifies potential hazards and has safety messages identified by the safety alert symbol (Figure 2), which signals a hazard that may cause serious injury or death if you do not follow the recommended precautions.



Figure 2

1. Safety alert symbol.

This manual uses two other words to highlight information.

Important calls attention to special mechanical information and **Note** emphasizes general information worthy of special attention.

Contents

Safety	3
Safe Operating Practices	3
Toro Mower Safety	4
Sound Power Level	5
Sound Pressure Level	5
Vibration Level	5
Safety and Instructional Decals	6
Setup	9
1 Installing the Target Plate	10
2 Installing the Cutting Unit to the Traction Unit	10
3 Installing the Handle Retainers	11
4 Installing the Battery Pack	11
5 Adjusting the EZ-Turn Sensor	14
6 Installing the Optional Transport Wheels	14
7 Installing the Grass Basket	15
Product Overview	16
Controls	17
Specifications	20
Attachments/Accessories	20
Operation	20
Think Safety First	20
Adjusting the Handle Height	20
Adjusting the Handle Angle	20
Turning On the Machine	21
Turning Off the Machine	21
Operating in Transport Mode	21
Preparing to Mow	21
Mowing Operation	21
Checking the Operation of the Interlock Switches	23
Lithium Ion Battery Pack Care	23

Safety

This machine meets or exceeds CEN standard EN 836:1997, ISO standard 5395:1990, and ANSI B71.4-2004 specifications in effect at the time of production.

Improper use or maintenance by the operator or owner can result in injury. To reduce the potential for injury, comply with these safety instructions and always pay attention to the safety alert symbol (Figure 2), which means CAUTION, WARNING, or DANGER-“personal safety instruction.” Failure to comply with the instruction may result in personal injury or death.

Safe Operating Practices

The following instructions are adapted from the CEN standard EN 836:1997, ISO standard 5395:1990, and ANSI B71.4-2004.

Training

- Read the *Operator's Manual* and other training material carefully. Be familiar with the controls, safety signs, and the proper use of the equipment.
- Never allow children or people unfamiliar with these instructions to use or service the mower. Local regulations may restrict the age of the operator.
- Never mow while people, especially children, or animals are nearby.
- Keep in mind that the operator or user is responsible for accidents or hazards occurring to other people or their property.
- The owner/user can prevent and is responsible for accidents or injuries occurring to himself or herself, other people, or property.

Preparation

- While mowing, always wear substantial footwear, long trousers, hard hat, safety glasses, and ear protection. Long hair, loose clothing, or jewelry may get tangled in moving parts. Do not operate the equipment when barefoot or wearing open sandals.
- Thoroughly inspect the area where the equipment is to be used and remove all objects which may be thrown by the machine.
- Check that operator presence controls, safety switches, and shields are attached and functioning properly. Do not operate unless they are functioning properly.

Operation

- Mow only in daylight or in good artificial light.
- Before attempting to turn on the machine, disengage all blade attachment clutches, shift into neutral, and engage the parking brake.
- Stay alert for holes in the terrain and other hidden hazards.

Using the InfoCenter LCD Display	24
Releasing the Transmission	26
Setting the Machine to Match Turf Conditions	27
Maintenance	28
Recommended Maintenance Schedule(s)	28
Daily Maintenance Checklist	28
Pre-maintenance Procedures	30
Disconnecting the Battery	30
Lubrication	30
Greasing the Motor Coupler	30
Electrical System Maintenance	31
Servicing the Battery Pack.....	31
Shipping the Battery Pack for Service	31
Replacing Fuses	31
Servicing the Traction Interlock Switch.....	32
Servicing the Mow Sensor.....	32
Servicing the Brake Interlock Switch	33
Brake Maintenance	33
Adjusting the Service/Parking Brake	33
Belt Maintenance	34
Inspecting the Reel Drive Belt	34
Transmission Cover Access Hole.....	34
Transmission Belt Tensioner	34
Controls System Maintenance	35
Adjusting the Reel Control.....	35
Cleaning	36
Cleaning the Machine.....	36
Storage	37
Storing the Machine.....	37
Removing the Machine from Storage.....	37
Schematics	38

- Watch out for traffic when crossing or near roadways.
- Stop the blades rotating before crossing surfaces other than grass.
- When using any attachments, never direct discharge of material toward bystanders nor allow anyone near the machine while in operation.
- Never operate the machine with damaged guards, shields, or without safety protective devices in place. Be sure all interlocks are attached, adjusted properly, and functioning properly.
- Before leaving the operator's position:
 - Stop on level ground.
 - Disengage the traction/mow lever.
 - Set the parking brake.
 - Turn off the machine.
- Disengage drive to attachments when transporting or not in use.
- Turn off the machine and disengage the traction/mow lever in the following situations:
 - Before connecting the battery to the charger
 - Before removing the grass basket
 - Before making height adjustment unless adjustment can be made from the operator's position
 - Before clearing blockages
 - Before checking, cleaning or working on the mower
 - After striking a foreign object or if an abnormal vibration occurs. Inspect the mower for damage and make repairs before restarting and operating the equipment.
- Keep hands and feet away from the cutting unit.
- Slow down and use caution when making turns and crossing roads and sidewalks. Stop reels if not mowing.
- Do not operate the mower under the influence of alcohol or drugs.
- Lightning can cause severe injury or death. If lightning is seen or thunder is heard in the area, do not operate the machine; seek shelter.
- Use care when loading or unloading the machine into a trailer or truck.
- Use care when approaching blind corners, shrubs, trees, or other objects that may obscure vision.
- Be careful during adjustment of the machine to prevent entrapment of the fingers between moving blades and fixed parts of the machine.
- Disengage drives, disengage the cutting unit, set the parking brake, turn off the machine, and disconnect the battery. Wait for all movement to stop before adjusting, cleaning, or repairing.
- Clean grass and debris from the cutting unit and drives to help prevent fires.
- Carefully release pressure from components with stored energy.
- Disconnect the battery before making any repairs.
- Use care when checking the reel. Wear gloves and use caution when servicing them.
- Keep hands and feet away from moving parts. If possible, do not make adjustments with the motor running or the battery connected to the machine..

Toro Mower Safety

The following list contains safety information specific to Toro products or other safety information that you must know that is not included in the CEN, ISO, or ANSI standard.

This product is capable of amputating hands and feet and throwing objects. Always follow all safety instructions to avoid serious injury or death.

Use of this product for purposes other than its intended use could prove dangerous to user and bystanders.

- Know how to stop the motor quickly.
- Do not operate the machine while wearing tennis shoes or sneakers.
- Wearing safety shoes and long pants is advisable and required by some local ordinances and insurance regulations.
- Check the safety interlock switches daily for proper operation. If a switch should fail, replace the switch before operating the machine.
- Always stand behind the handle when starting and operating the machine.
- Using the machine demands attention. To prevent loss of control:
 - Do not drive close to sand traps, ditches, creeks, or other hazards.
 - Reduce speed when making sharp turns. Avoid sudden stops and starts.
 - When near or crossing roads, always yield the right-of-way.
- The grass basket must be in place during the mowing operation for maximum safety. Shut the motor off before emptying the basket.
- When a person or animal enters the mowing area, stop mowing. Careless operation, combined with terrain angles, ricochets, or improperly positioned guards can

Maintenance and Storage

- Keep all nuts, bolts, and screws tight to be sure the equipment is in safe working condition.
- To reduce the fire hazard, keep the battery pack and connectors free of debris.
- Check the grass basket frequently for wear or deterioration.
- Keep all parts in good working condition and all hardware tightened. Replace all worn or damaged parts and decals.

lead to thrown object injuries. Do not resume mowing until the area is cleared.

Maintenance and Storage

- Do not open or alter the battery pack in any way. Opening it may expose you to dangerous electrical voltage. The warranty will be voided if you attempt to open the battery pack. With the exception of the fuse, fuse cover, and labels, there are **no consumer serviceable parts** on or in the battery pack.
- If the motor must be running to perform a maintenance adjustment, keep hands, feet, clothing, and any parts of the body away from the cutting unit, attachments, and any moving parts. Keep everyone away.
- If major repairs are ever needed or if assistance is desired, contact an Authorized Toro Distributor.
- Use only Toro-approved attachments and replacement parts. The warranty may be voided if used with unapproved attachments or parts.

Sound Power Level

- **Model 04042:**

This unit has a guaranteed sound power level of 84.4 dBA, which includes an Uncertainty Value (K) of 1 dBA.

Sound power level was determined according to the procedures outlined in EN 11094.

- **Model 04043:**

This unit has a guaranteed sound power level of 83 dBA, which includes an Uncertainty Value (K) of 1 dBA.

Sound power level was determined according to the procedures outlined in EN 11094.

Sound Pressure Level

- **Model 04042:**

This unit has a sound pressure level at the operator's ear of 79 dBA, which includes an Uncertainty Value (K) of 1 dBA.

Sound pressure level was determined according to the procedures outlined in EN 836.

- **Model 04043:**

This unit has a sound pressure level at the operator's ear of 68 dBA, which includes an Uncertainty Value (K) of 1 dBA.

Sound pressure level was determined according to the procedures outlined in EN 836.

Vibration Level

Hand-Arm

- **Model 04042:**

Measured vibration level for right hand = 0.24 m/s²

Measured vibration level for left hand = 0.36 m/s²

Uncertainty Value (K) = 0.18 m/s²

- **Model 04043:**

Measured vibration level for right hand = 0.36 m/s²

Measured vibration level for left hand = 0.24 m/s²

Uncertainty Value (K) = 0.18 m/s²

Measured values were determined according to the procedures outlined in EN 836.

Safety and Instructional Decals



Safety decals and instructions are easily visible to the operator and are located near any area of potential danger. Replace any decal that is damaged or lost.

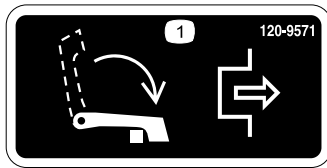

120-9571

1. Lower the lever to disengage the traction.



120-9573

1. Read the *Operator's Manual*.
2. Warning—do not operate the machine unless you are trained.
3. Warning—keep bystanders away from the battery.
4. Electrical shock hazard—do not allow tools to short circuit battery posts when performing maintenance.



120-9570

1. Warning—stay away from moving parts, keep all guards and shields in place.



120-9593

1. Read the *Operator's Manual*.
2. Warning—do not operate the machine unless you are trained.
3. Thrown object hazard—keep bystanders a safe distance from the machine.
4. Warning—stay away from moving parts, keep all guards and shields in place.
5. Do not tow the machine.

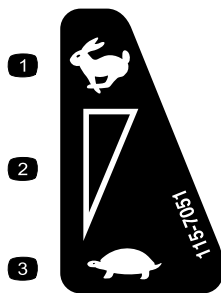

115-7051

1. Fast
2. Continuous variable setting
3. Slow—Zero position

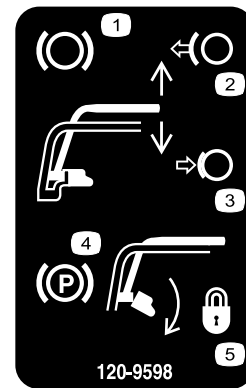

120-9598

1. Brake
2. Release handle to disengage the brake.
3. Compress the handle to engage the brake lever.
4. Parking brake
5. Rotate the latch to lock the parking brake; compress the handle to release the latch.

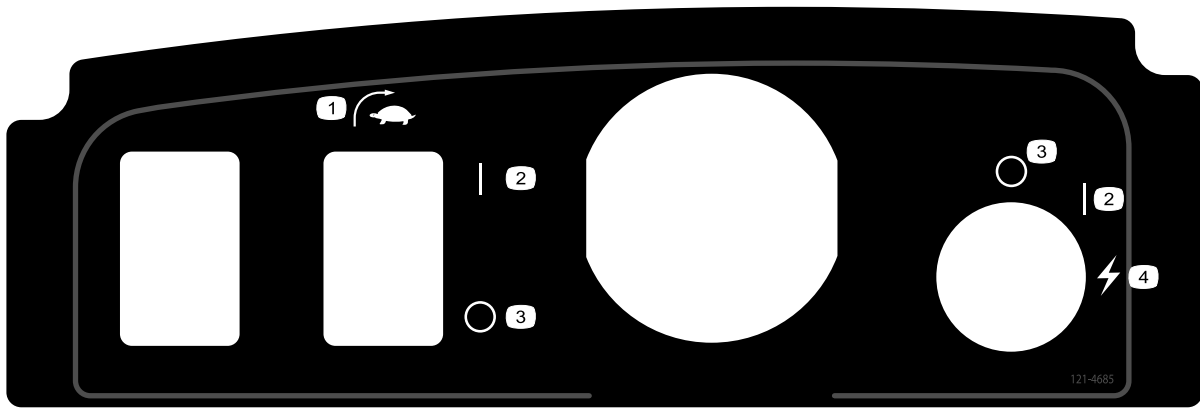

121-4685

1. EZ-Turn switch 2. On 3. Off 4. Start (machine)

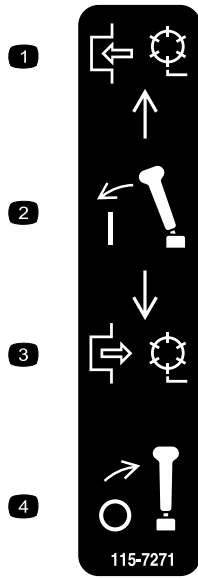

115-7271

1. Engage the reel. 3. Disengage the reel.
2. Engage the lever. 4. Disengage the lever.



119-7523

1. Warning—read the *Operator's Manual*.
2. Explosion hazard—no sparks or open flames.
3. Electric shock hazard—do not allow battery posts to short circuit.
4. Warning—do not operate this machine unless you are trained.
5. Warning—do not remove battery cover, do not place in water, do not use a battery with a cracked or damaged housing.
6. Poison hazard—keep children away from the battery.

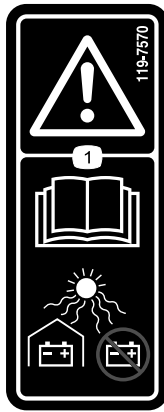

119-7570

1. Warning—read the *Operator's Manual*; keep batteries sheltered, do not store in direct sunlight.
-

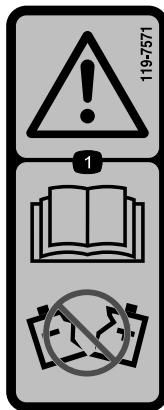

119-7571

1. Warning—read the *Operator's Manual*; do not use a battery with a cracked or damaged housing.
-

Setup

Loose Parts

Use the chart below to verify that all parts have been shipped.

Procedure	Description	Qty.	Use
1	Target plate	1	Install the target plate.
2	Bolt, 3/8 x 3/4 inch	2	Install the cutting unit to the traction unit
3	Handle retainer Hair pin cotter	2 2	Install the handle retainers
4	Battery pack Bolt (5/16 x 1/2 inch) Washer	1 6 6	Install the battery pack.
5	No parts required	–	Adjust the EZ-Turn sensor.
6	Transport wheels (Optional Transport Wheel Kit, Model 04123)	2	Install the transport wheels.
7	Grass basket	1	Install the grass basket.

Media and Additional Parts

Description	Qty.	Use
Operator's Manual	1	Read or view before operating the machine
Parts Catalog	1	
Operator Training Material	1	
Certificate of Compliance	1	

Note: Determine the left and right sides of the machine from the normal operating position.

1

Installing the Target Plate

Parts needed for this procedure:

1	Target plate
---	--------------

Procedure

1. Setup and prepare the cutting unit as described in the cutting unit *Operator's Manual*.
2. Remove the center, grass shield bolt (Figure 3).
3. Install the target plate to the top of the cutting unit using the bolt you removed previously (Figure 3).

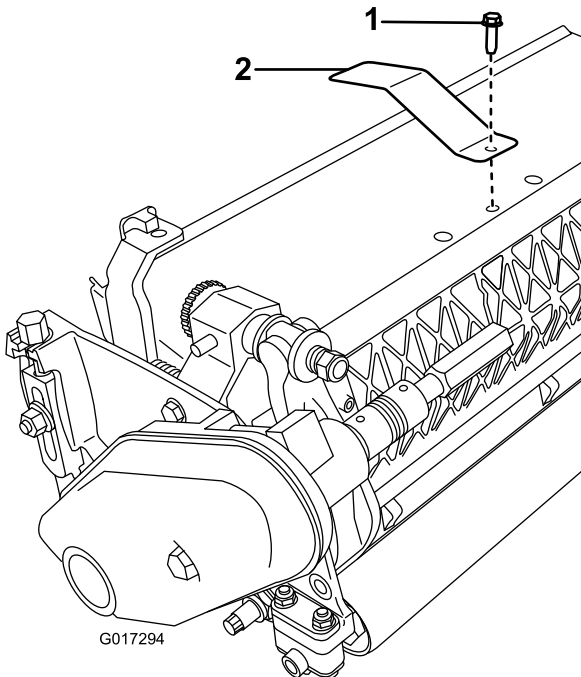

Figure 3

1. Center, grass shield bolt
2. Target plate

2

Installing the Cutting Unit to the Traction Unit

Parts needed for this procedure:

2	Bolt, 3/8 x 3/4 inch
---	----------------------

Procedure

1. Place the mower on its drums on a level surface.
2. Lower the kick stand and push in the locking pin to lock the kick stand in the service position (Figure 4). Allow the machine to rest on the locked kickstand.

Note: Place the kickstand in this position anytime you remove the reel. This will keep the machine from tipping backwards onto the handle.

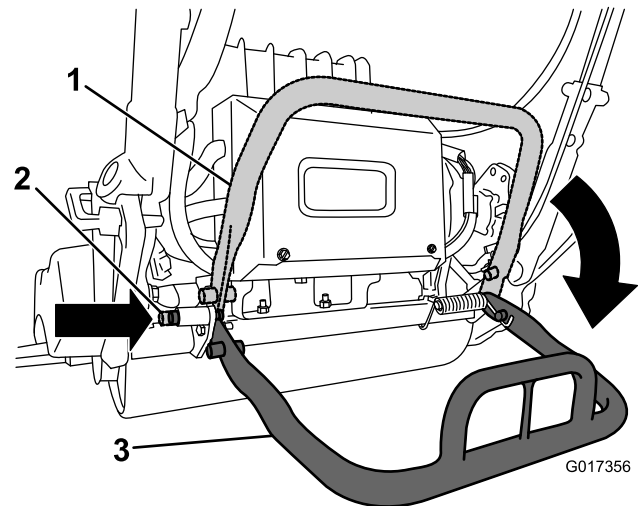

Figure 4

1. Kickstand—storage position
2. Locking pin
3. Kickstand—service position

3. Push the cutting unit under the traction unit and to the left to engage the transmission coupling (Figure 5).

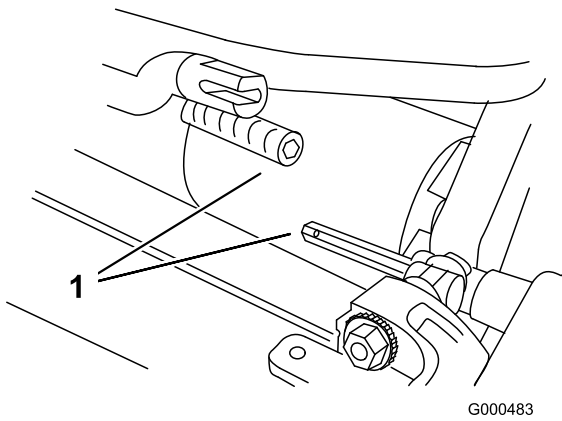

Figure 5

1. Transmission coupling

4. Maneuver the traction unit frame (Figure 6) forward until it engages the cutting unit pivot arms.

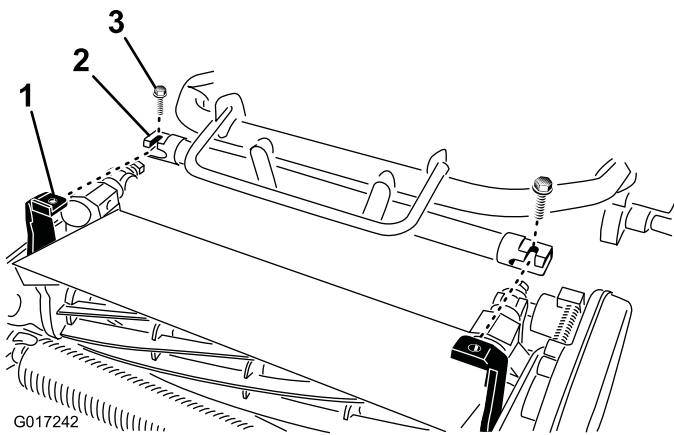

Figure 6

Battery platform not shown.

1. Telescoping coupler
2. Cutting unit hex shaft

5. Secure the traction unit frame to the cutting unit pivot arms with 2 bolts (3/8 x 3/4 inch) (Figure 6).

Note: To remove the cutting unit, just loosen the 2 bolts (3/8 x 3/4 inch) approximately 1-1/2 turns and rotate the pivot arms out.

6. Slide the telescoping coupler onto the cutting unit hex shaft until detent in the hex shaft is felt. This will prevent the coupler from moving on the hex shaft (Figure 6).
7. Push down on the kick stand to release the spring loaded locking pin and allow the kick stand to rotate up to the storage position.
8. Set the height-of-cut of the reel as described in the reel *Operator's Manual*.

3

Installing the Handle Retainers

Parts needed for this procedure:

2	Handle retainer
2	Hair pin cotter

Procedure

1. While supporting the handle, remove the cable ties securing the handle clamps to the side plates (Figure 7).

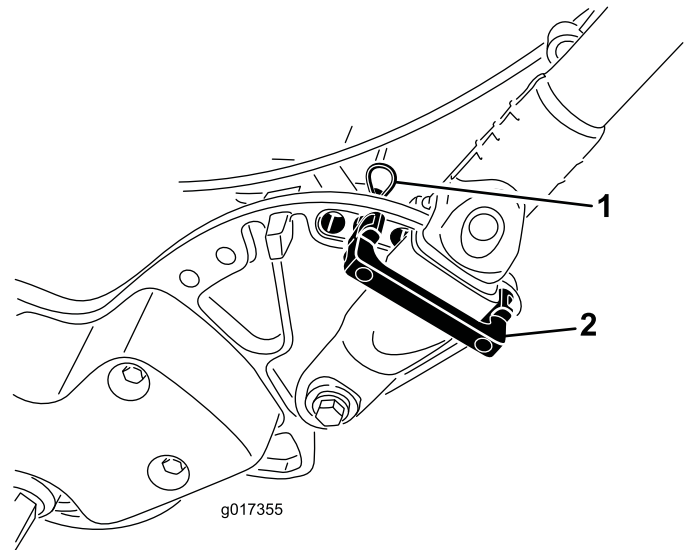

Figure 7

1. Hair pin cotter
2. Handle retainer

2. Pivot the handle to the desired operating position, insert a handle retainer over the handle clamp and into the matching holes in the side plate (Figure 7).
3. Secure the clamp in position with a hair pin cotter (Figure 7).
4. Repeat the procedure on the opposite side of the handle.
5. Adjust the handle height to the desired position; refer to [Adjusting the Handle Height \(page 20\)](#).

Note: The machine is shipped with the handle adjusted to the lowest position. The machine is traditionally operated with the handle telescoped out to its maximum height.

4

Installing the Battery Pack

Parts needed for this procedure:

1	Battery pack
6	Bolt (5/16 x 1/2 inch)
6	Washer

Procedure

1. Remove the battery pack from its carton, saving the carton and all packing material for future use.

Important: Save the carton and all packing materials. If you ever need to ship the battery for maintenance, warranty, or recycling, you will need this special packaging.

Refer to the Installation Instructions included with the Battery Shipping Kit, 120-4600 (a PDF of these instructions is available at no charge from www.toro.com).

2. Cut the cable tie securing the battery charger to the battery base on the machine and remove the charger.
3. Disconnect the small connector on the pack to machine wiring harness from the main wiring harness (Figure 12).
4. Remove the tall nut that secures the rear of the battery base to the machine frame (Figure 8).

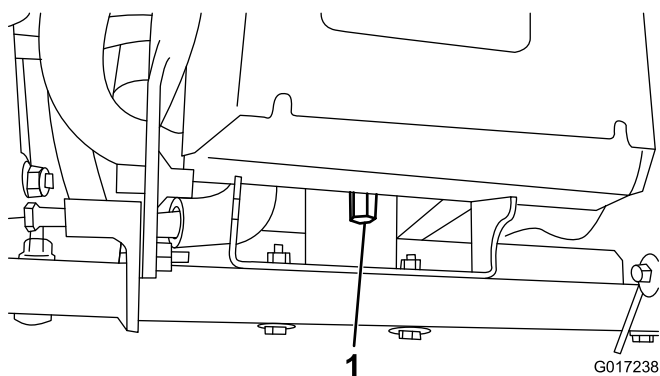

Figure 8

1. Tall nut

5. Loosen the 2 pivot bolts/nuts a half turn each (Figure 9).

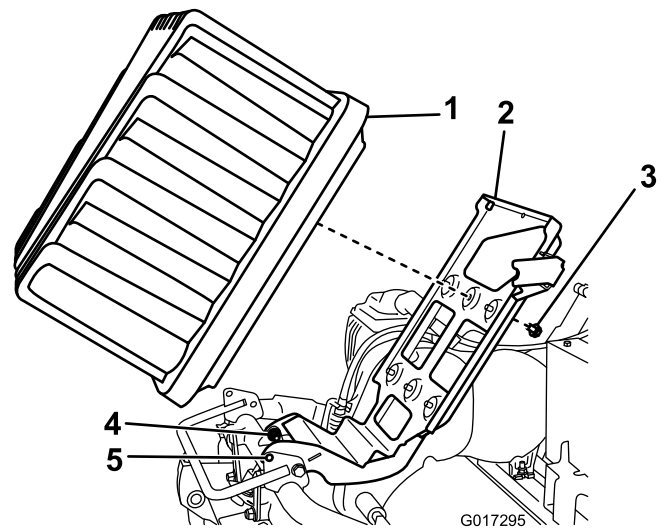

Figure 9

1. Battery pack
2. Battery platform
3. Bolt and washer
4. Pivot bolts
5. Locking holes

6. Raise the battery platform until the locking holes in the base and frame align (Figure 9). Slide a screw driver or other steel rod through the holes to hold the platform in the raised position.
7. Place the battery pack on the base with the connector port toward the rear of the machine.
8. Secure the battery pack to the base using 6 bolts (5/16 x 1/2 inch) and washers. Torque each bolt to 100 to 130 in-lb (11.3 to 14 N-m).
9. Line up the tabs on the inside of the harness power plug with the slots in the battery pack receptacle. Press the harness connector into the battery connector (Figure 10 and Figure 11).

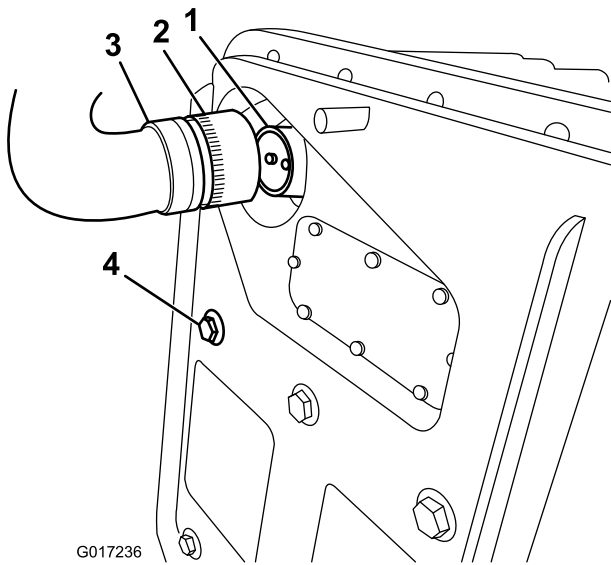

Figure 10

- | | |
|----------------------------|--------------------------------------|
| 1. Battery pack receptacle | 3. Pack to machine wire harness plug |
| 2. Locking collar | 4. Bolt securing the battery pack |

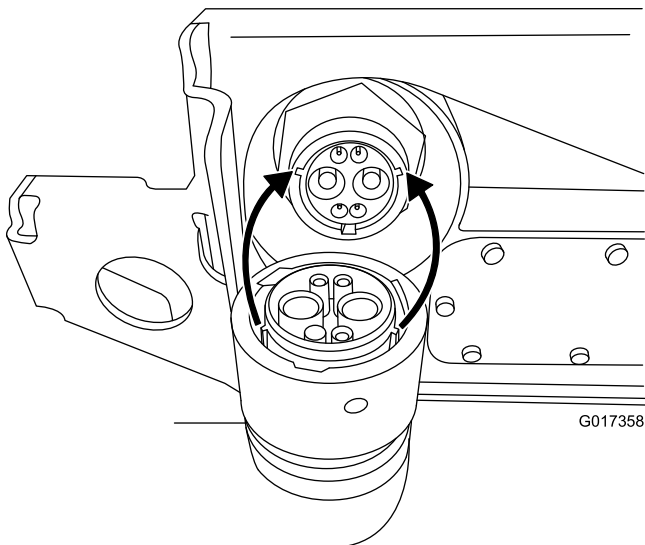

Figure 11

10. Rotate the locking collar on the harness plug clockwise until it engages with the battery receptacle and begins to pull in toward the battery. Continue turning it another 120 degrees (1/3 of a turn) until it fully seats.

Note: If you cannot mate the battery pack receptacle with the machine wire harness plug while the battery pack is installed, you can instead connect the harness to the battery pack and then install the battery pack. Remove the main power supply connector (Figure 13) from the battery base. Install the connector to the battery as described. Install the battery to the base, threading the attached wiring harness through the appropriate hole, and then secure the main power

supply connector to the battery base using the fasteners previously removed.

11. Remove the screwdriver holding the battery base in the up position, and gently lower the battery platform to the machine frame.

Important: Do not pinch the wiring harness between the frame and platform.

12. Secure the battery platform to the machine frame with the tall nut removed in step 4.
13. Tighten the pivot fasteners loosened in step 5.
14. Route the pack to machine wire harness under and behind the main harness on the left side of the machine and connect the small, 6 pin connector on the harness to the matching connector on the main wiring harness as shown in Figure 12.

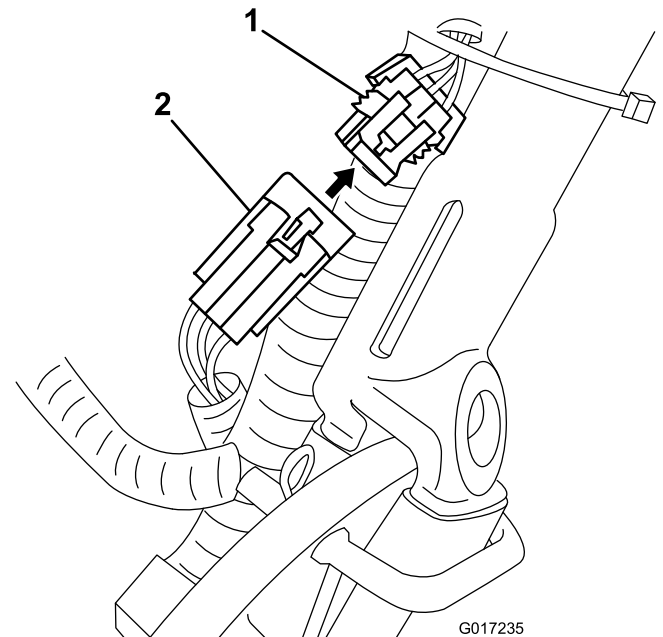

Figure 12

- | | |
|---|--|
| 1. Connector on the main wiring harness | 2. Small connector from the pack to machine wire harness |
|---|--|

15. Connect the T-handle connector from the main wiring harness to the main power supply connector on the battery base (Figure 13).

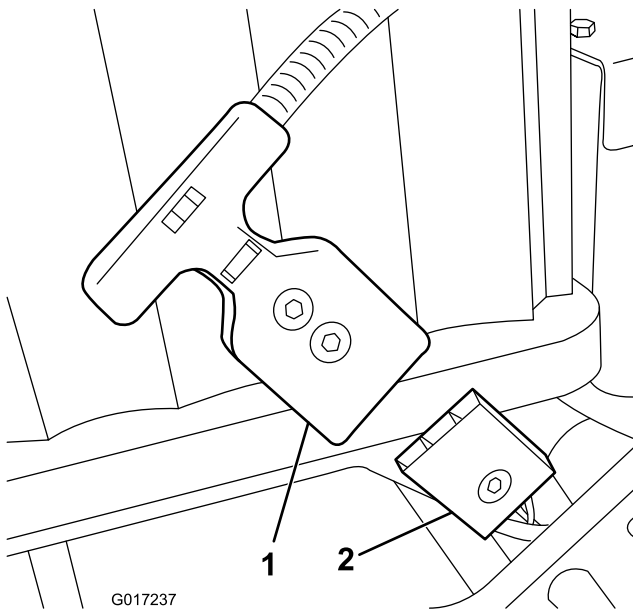

Figure 13

1. T-handle connector
2. Main power supply connector on the battery platform

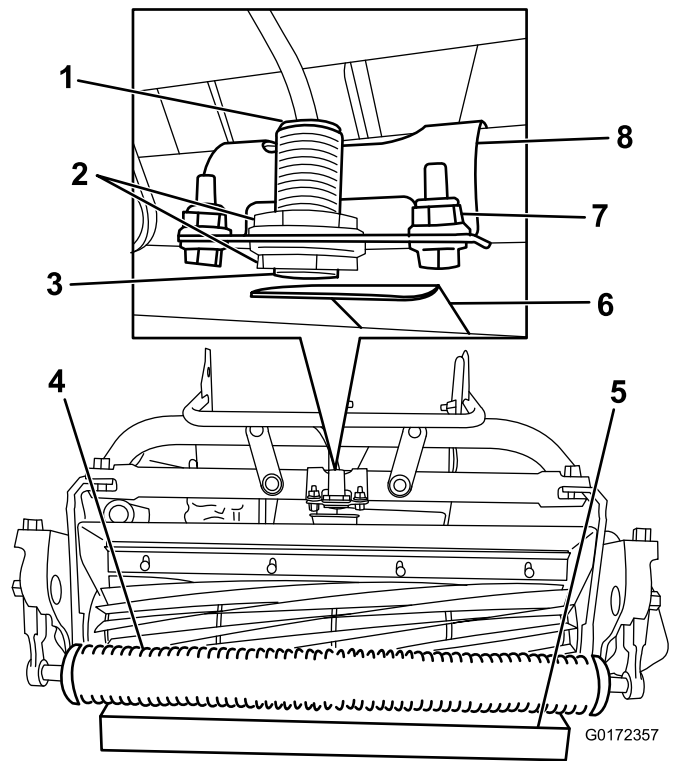

Figure 14

1. Sensor light (on top)
2. Jam nuts
3. EZ-Turn sensor
4. Roller
5. 1-1/2 inch (3.8 cm) block
6. Target plate
7. Bracket fasteners
8. Sensor bracket

16. Charge the battery as described in the instructions that came with the battery charger.

Note: The battery is shipped with a partial charge (approximately 40%). This is enough for you to perform functional checks on the machine and move it as needed to complete setup, but you should fully charge the battery before using the machine.

5

Adjusting the EZ-Turn Sensor

No Parts Required

Procedure

1. Ensure that the unit is on a flat, level surface with the traction drum on the ground.
2. Loosen the jam nuts on the sensor and adjust the sensor so that one thread is visible past the lower jam nut (Figure 14).

3. Tighten the jam nuts to secure the sensor.
4. Place a 1-1/2 inch (3.8 cm) block under the front cutting unit roller (Figure 14).
5. Loosen the fasteners securing the sensor bracket to the frame (Figure 14).
6. Turn on the machine; refer to [Turning On the Machine](#) (page 21).
7. Set the EZ-Turn switch to the On position; refer to [EZ-Turn Switch](#) (page 17).
8. Rotate the sensor bracket toward the target plate until the light on top of the sensor illuminates (Figure 14). If it was already illuminated, rotate it away from the target plate until it goes out and then reverse direction just until it illuminates again.
9. Tighten the bracket fasteners.
10. Remove the block from under the roller and place the machine on the kickstand.
11. Ensure that the target plate does not contact the grass shield. If it does, loosen the bracket fasteners and rotate the switch up just until the target plate is no longer touching the grass shield.
12. Turn off the machine.

6

Installing the Optional Transport Wheels

Parts needed for this procedure:

2	Transport wheels (Optional Transport Wheel Kit, Model 04123)
---	--

Procedure

1. Push the kick stand down with your foot and pull up on the handle support until the kick stand has rotated forward, over center (Figure 15).

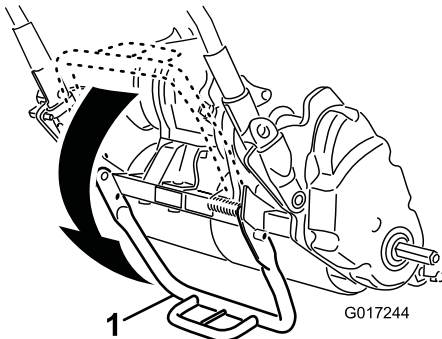

Figure 15

1. Kickstand

2. Press the wheel locking clip toward the center of the wheel and slide the wheel onto the hex shaft (Figure 16).

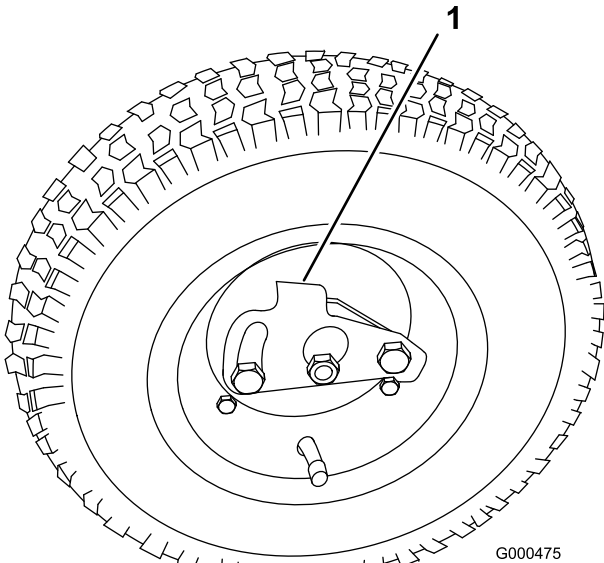

Figure 16

1. Locking clip

3. Rotate the wheel back and forth until it slides completely onto the axle and the locking clip is secured in the groove on the axle shaft.
4. Repeat the procedure on the opposite side of the machine.
5. Inflate the tires to 12-15 psi (83-103 kPa).
6. Carefully lower the machine off of the kickstand.

7

Installing the Grass Basket

Parts needed for this procedure:

1	Grass basket
---	--------------

Procedure

1. Grasp the basket by the handle (Figure 17).

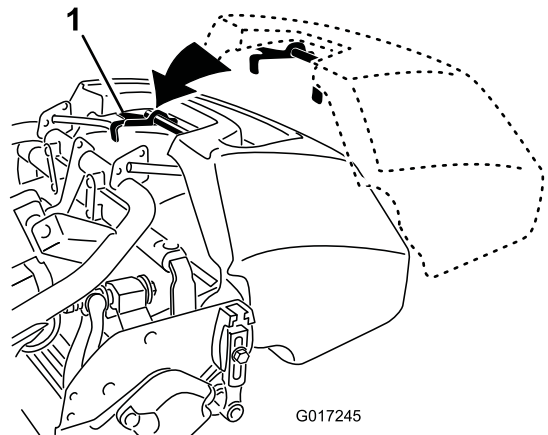

Figure 17

1. Basket hooks

2. Guide the basket lip between the cutting unit side plates and over the front roller (Figure 17).
3. Install the basket hooks over the frame loop (Figure 17).

Important: If you ever drop the basket, examine the pitch arm contact points near the lower lip of the basket for damage (Figure 18). Straighten them before using the basket. Using the basket with bent pitch arm contact points could damage the reel.

Product Overview

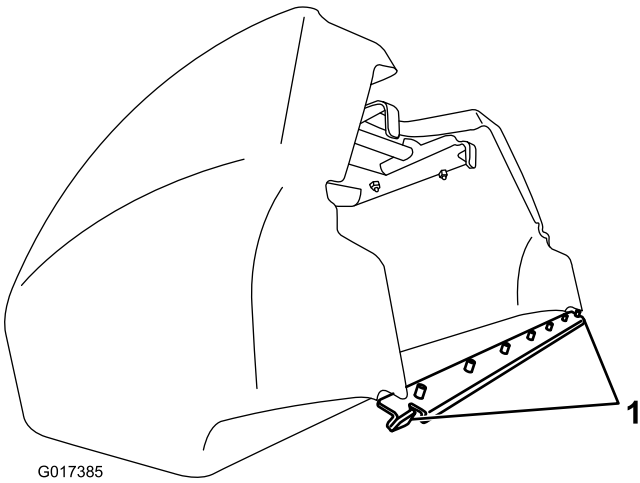

Figure 18

1. Pitch arm contact point
-

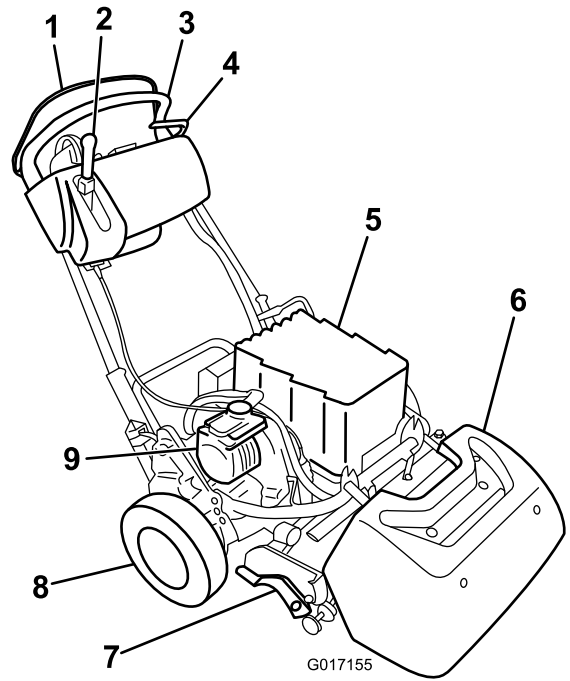

Figure 19

- | | |
|---|---------------------|
| 1. Operator presence control | 6. Grass basket |
| 2. Traction & reel drive engagement lever | 7. Cutting unit |
| 3. Handle | 8. Transport wheels |
| 4. Service brake | 9. Electric motor |
| 5. Battery pack | |
-

Controls

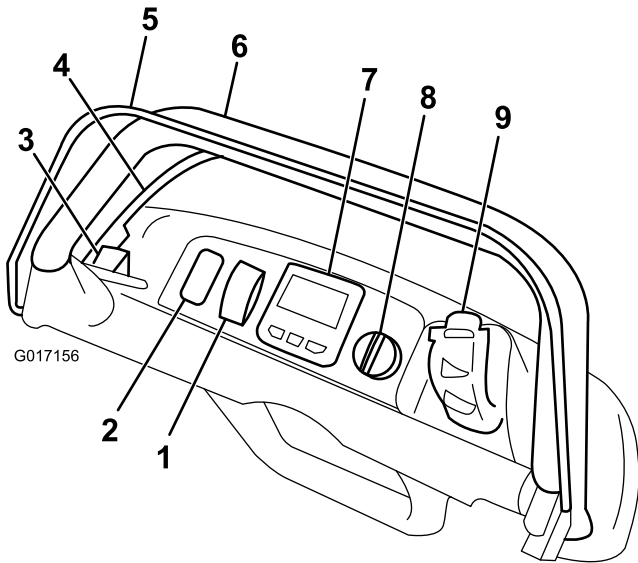

Figure 20

- | | |
|-----------------------------------|---------------------------|
| 1. EZ-Turn switch | 6. Handle |
| 2. Open space for optional lights | 7. InfoCenter LCD display |
| 3. Parking brake latch | 8. Key switch |
| 4. Service brake | 9. Speed control |
| 5. Operator presence control | |

EZ-Turn Switch

The EZ-turn switch (Figure 20) enables or disables the EZ-Turn feature. EZ-Turn is a feature that automatically slows the machine whenever you raise the cutting unit off of the ground during mowing. This allows you to make the turns at the end of each mowing pass at a slower speed. You can use the switch at any time, even while mowing.

This feature only reduces ground speed when the reel is engaged and lifted off of the ground. It has no effect on ground speed when the reel is disengaged. If this feature is activated while mowing and you turn off the reel, the machine will speed up. If you are mowing at a slow speed already, the EZ-Turn feature will not slow the machine on a turn.

Service Brake

The service brake (Figure 21) is located on the left front side of the handle. Pulling the lever back will apply the service brake. If you operate the machine with the brake on, it will move, but with high resistance and power consumption will increase.

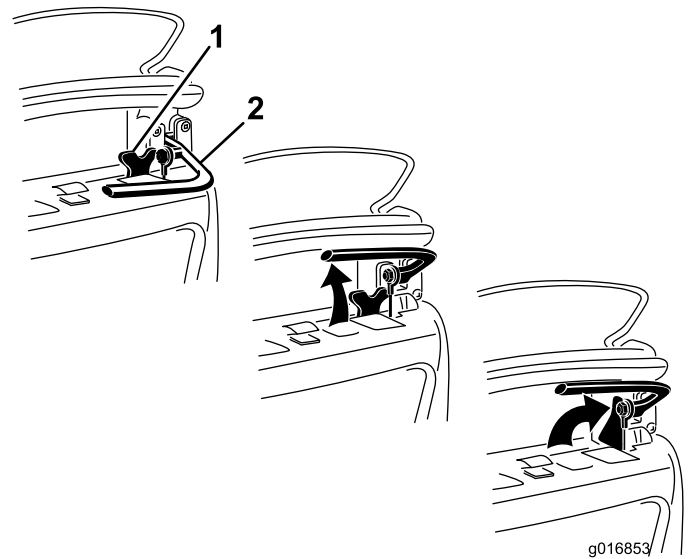

Figure 21

- | | |
|------------------------|------------------|
| 1. Parking brake latch | 2. Service brake |
|------------------------|------------------|

Parking Brake Latch

Use the parking brake latch (Figure 21) in conjunction with the service brake. Rotate the parking brake latch toward the brake handle to hold the service brake in place. Pull the brake lever to release. The traction control lever will not engage with the latch engaged.

Operator Presence Control (OPC)

You must engage the operator presence control (Figure 20) before engaging the traction lever. If you release the OPC during operation, the traction lever will return to neutral but the machine will not turn off.

InfoCenter LCD Display

The InfoCenter LCD display shows information about your machine and battery pack such as the current battery charge, the speed, diagnostics information, and more (Figure 20).

For more information, refer to [Using the InfoCenter LCD Display \(page 24\)](#).

Key Switch

The key switch (Figure 20) has three positions: Off, Run, and Start. With the brake off and the traction drive disengaged, move the switch to the Start position for a few seconds until the InfoCenter display lights up, then release it to the Run position. Turn it to the Off position and remove the key to turn off the machine.

Speed Control

The speed control (Figure 20 and Figure 22) is located on the right rear side of the control panel. Rotate the control

to regulate the machine ground/cutting speed. The current speed setting is reflected on the InfoCenter LCD display.

Note: In order for the machine to move, you must have both the traction lever engaged and the speed control off of the zero speed position.

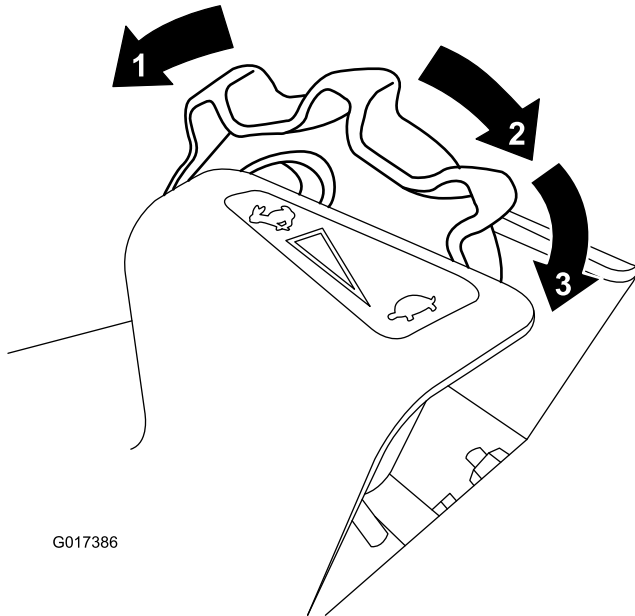

Figure 22

- | | |
|---------------|---------------|
| 1. Full speed | 3. Zero speed |
| 2. Slow speed | |

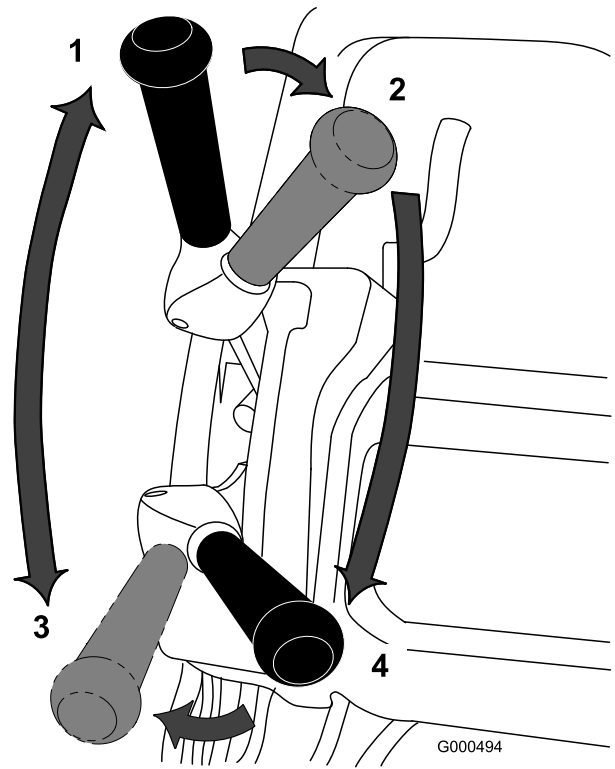

Figure 23

- | | |
|--|--|
| 1. Neutral | 3. Traction drive-engaged (transport) |
| 2. Traction drive neutral & reel drive off | 4. Traction drive & reel drive engaged |

If you rotate the speed control to the zero speed setting (as far back as possible) all cutting/transport activities will cease and the machine will stop. If you do this while mowing (with the traction/reel drive lever engaged), the machine will stop with the automatic motor brake off (refer to [Automatic Motor Brake \(page 18\)](#)) and you will be able to pull the machine rearward at that point. Move the speed control off of zero speed to resume cutting/transport.

Traction and Reel Drive Engagement Lever

The traction and reel drive engagement lever ([Figure 23](#)) is located on the front right side of the control panel. For transport operation, the lever has two positions: Neutral and Forward. Pushing the lever forward engages the traction drive.

Note: To move the lever you must first engage the operator presence control.

For reel operation, the lever has two positions: Engage and Disengage. Move the top of the lever to the left then forward to engage the reel and begin mowing. Push the lever to the right to disengage the reel and continue forward motion or pull back on it to disengage both the reel and the traction drive.

Note: If you release the operator presence control, the lever will return to Neutral and the machine will stop.

Automatic Motor Brake

The machine is equipped with an automatic motor brake that prevents it from rolling when the machine is stopped. The motor brake is on whenever the traction drive is in neutral or you move the speed control to the zero speed position, except in the following circumstances:

- When the machine is turned off—use the parking brake latch to secure the machine when turned off.
- When the machine is started with the key switch, the motor brake is initially disengaged. After driving the machine, the motor brake will function normally.
- If you move the speed control to zero speed while the reels are engaged (i.e., while mowing), the brake will not engage. This feature allows you to move to the zero position while mowing and pull the machine rearwards to make course corrections.

Kickstand

The kickstand (Figure 25) is mounted to the rear of the machine and is used to raise the rear of the machine for installation or removal of the transport wheels and to keep the machine for falling onto the handle when you remove the reel.

- To use the kickstand to install the transport wheels, lower it to the ground and step down on the kickstand loop while pulling up and back on the lower center machine handle (Figure 24).

Important: Only put foot pressure down on the kickstand loop, and only use the lower center machine handle to raise the unit. Attempting to raise the unit onto the kickstand by any other means can cause injury.

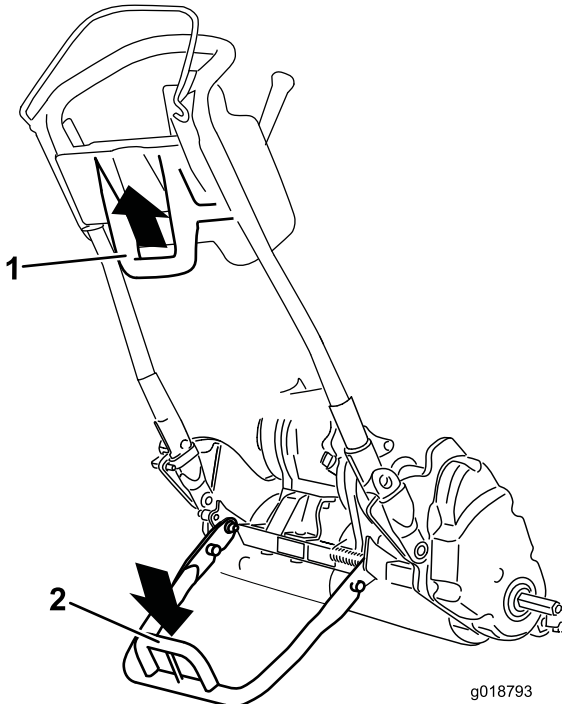

Figure 24

1. Lower center machine handle 2. Kickstand loop

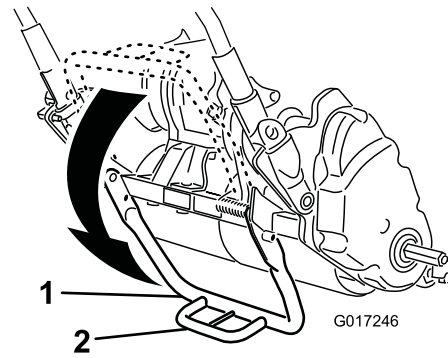

Figure 25

1. Kickstand 2. Kickstand loop

- To use the kickstand when removing the reel, lower it and push in the locking pin to lock the kickstand in the service position (Figure 26).

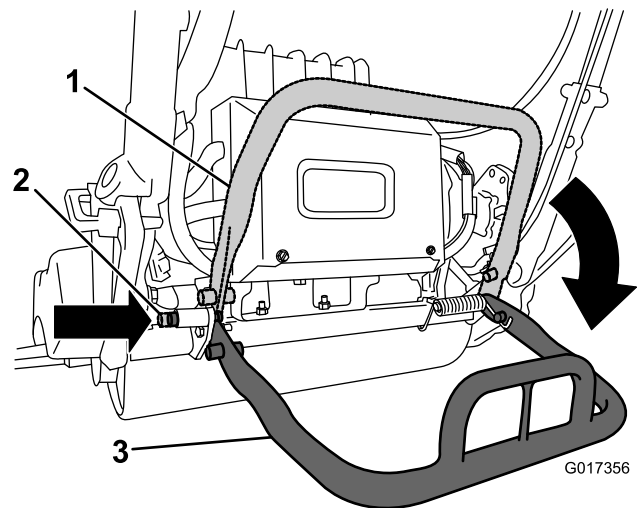

Figure 26

1. Kickstand—storage position 3. Kickstand—service position
2. Locking pin

Specifications

1800 Traction Unit

Width	32-1/2 inches (82.5 cm)
Height	41-1/4 inches (104.8 cm)
Length with basket	60 inches (152.4 cm)
Net Weight (with 11 blade cutting unit and grass basket installed)	285 lb (129.3 kg)
Width of cut	18 inches (46 cm)
Height of cut	1/16 to 19/64 inches (1.5 to 7.5 mm) with Micro-Cut bedknife
Clip frequency	Adjustable (Refer to Cutting Unit Operator's Manual)

2100 Traction Unit

Width	35-1/2 inches (90.1 cm)
Height	41-1/4 inches (104.8 cm)
Length with basket	60 inches (152.4 cm)
Net Weight (with 11 blade cutting unit and grass basket installed)	293 lb (132.9 kg)
Width of cut	21 inches (53.3 cm)
Height of cut	1/16 to 19/64 inches (1.5 to 7.5 mm) with Micro-Cut bedknife
Clip frequency	Adjustable (Refer to Cutting Unit Operator's Manual)

Attachments/Accessories

A selection of Toro approved attachments and accessories is available for use with the machine to enhance and expand its capabilities. Contact your Authorized Service Dealer or Distributor or go to www.Toro.com for a list of all approved attachments and accessories.

Operation

Note: Determine the left and right sides of the machine from the normal operating position.

Think Safety First

Please carefully read all of the safety instructions and decals in the safety section. Knowing this information could help you or bystanders avoid injury.

Adjusting the Handle Height

Note: The machine is shipped with the handle adjusted to the lowest position. The machine is traditionally operated with the handle telescoped out to its maximum height.

1. Loosen the 3 carriage bolts and nuts securing each side of the handle in the handle clamps (Figure 27).

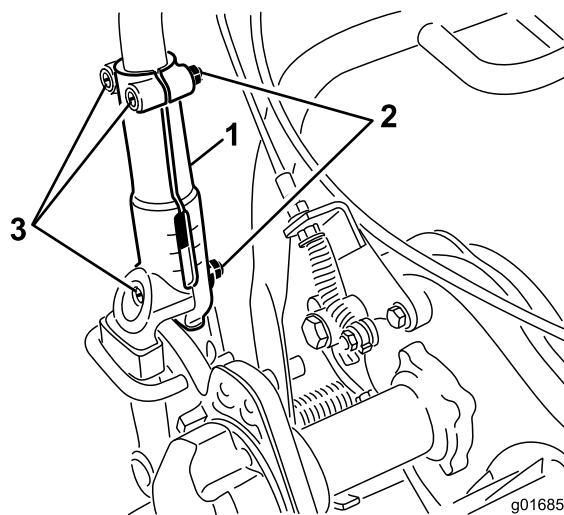

Figure 27

1. Handle clamp
2. Nut
3. Carriage bolts

2. Pull up on the handle slowly and evenly on each side until it is in the desired operating position.
3. Tighten the carriage bolts and nuts to lock the adjustment.

Adjusting the Handle Angle

1. Remove the hairpin cotters from the handle retainers on each side of the mower (Figure 28).

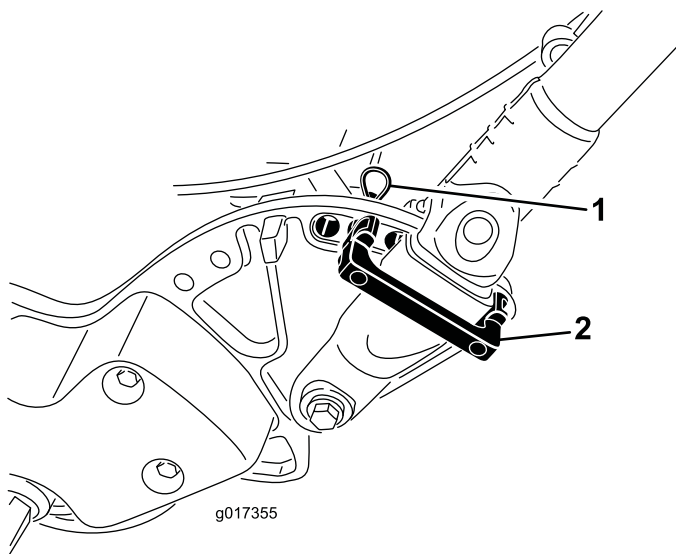

Figure 28

1. Hairpin cotter 2. Handle retainer

2. While supporting the handle, remove the hairpin cotters from each side and pivot the handle to the desired operating position (Figure 28).
3. Install the handle retainers and hairpin cotters.

Turning On the Machine

1. Ensure that the T-handle connector on the main wiring harness is connected to the main power supply connector (Figure 13).
2. Ensure that the traction and reel drive levers are in neutral.
3. Move the key switch to the Start position and hold it until the InfoCenter LCD display lights up, then release it to the Run position.

Turning Off the Machine

1. Disengage the traction and reel drive controls.
2. Turn the key switch to the Off position and remove the key.

Operating in Transport Mode

If you won't be using the transport wheels, proceed to step 4.

1. Push the kickstand down with your foot and pull up on the handle support until the kickstand has rotated forward, over center.
2. Install the transport wheels.
3. To release the kickstand, pull up on the handle and lower the rear of the mower onto the transport wheels.
4. Ensure that the traction and reel drive lever is in neutral and turn on the machine.

5. Set the speed control to Zero, engage the traction drive, tip the front of the machine up, and slowly increase the machine speed to begin moving.
6. Adjust the speed control to operate the mower at the desired ground speed and transport the mower to the desired destination.

Preparing to Mow

1. Return the speed control to the Zero position, disengage the traction control lever, and turn off the machine.
2. Push the kickstand down with your foot and pull up on the handle support until the kickstand has rotated forward, over center.
3. Remove the transport wheels.
4. Carefully lower the machine off of the kickstand.

Mowing Operation

Proper use of the machine provides the smoothest turf cutting available.

Important: Grass clippings act as a lubricant when mowing. Excessive operation of the cutting unit with the absence of grass clippings can damage the cutting unit.

Prior to Mowing

Ensure that the mower is carefully adjusted and is set evenly on both sides of the reel. For best performance and battery life, set the bed knife to have a light contact with the reel. Improper mower adjustment is magnified in the appearance of the clipped turf. Remove all foreign objects from the turf prior to mowing. Make sure everyone, especially children and pets, are clear of the work area.

Method of Mowing

The greens should be mowed in a straight back and forth direction across the green. Avoid circular mowing or turning the mower on the greens areas since scuffing may occur. Turning the mower should be done off the green by raising the cutting reel (pushing the handle down) and turning on the traction drum. If you enable the EZ-Turn switch, the traction unit will slow down when you raise the cutting unit making the turn more manageable, especially for novice users. Mowing should be done at a normal walking pace. Fast speeds save very little time and will result in an inferior mowing job.

To assist in maintaining a straight line across the green and to keep the machine an equal distance from the edge of the previous cut, use the alignment stripes on the basket (Figure 29).

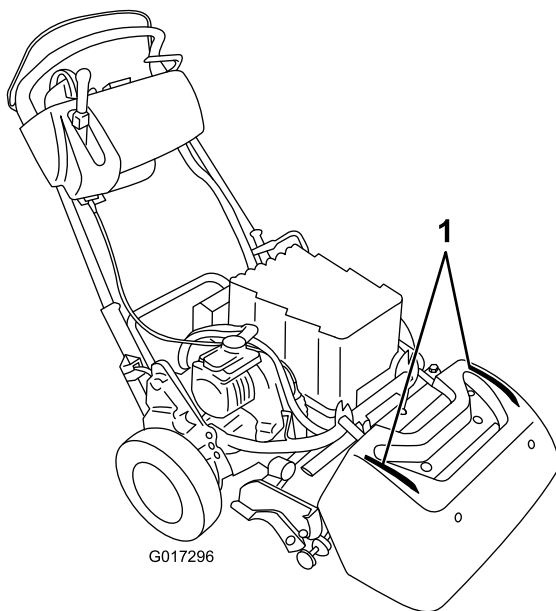

Figure 29

1. Alignment stripes

Operating in Low Light Conditions

When operating in low light conditions, use the LED Light Kit, Model 04265. This kit is specially designed to work well with the battery pack and electrical system.

Important: Do not use other light systems with this mower as they may damage the battery pack or electrical system.

Operating the Mower

To operate the controls while mowing:

1. Turn on the machine, set the speed control to the Zero position, push down on the handle to raise the cutting unit, press the operator presence control, move the traction lever to the Engaged position (Figure 30), and gradually increase the speed control setting to transport the mower onto the collar of the green .
2. Return the speed control to the Zero position.
3. Disengage the traction lever, then move it to the left and forward, engaging the traction and reel drive (Figure 30).

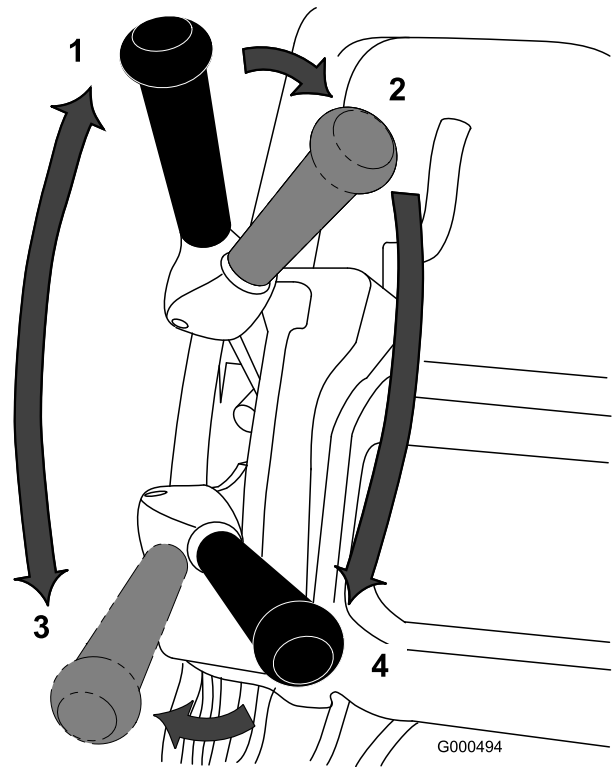

Figure 30

- | | |
|--|--|
| 1. Neutral | 3. Traction drive-engaged (transport) |
| 2. Traction drive neutral & reel drive off | 4. Traction drive & reel drive engaged |

4. Gradually increase the speed control setting until the mower is traveling at the desired ground speed, drive the mower out onto the green area, lower the front of the mower down and commence operation.

Note: While mowing, you can move the speed control to the Zero position. This will stop the machine with the motor brake off, allowing you to pull the machine rearwards to make course corrections. For more information on the automatic motor brake, refer to [Automatic Motor Brake \(page 18\)](#).

After Mowing

1. Drive off the green, reduce the speed to the Zero position, disengage the reel drive and traction control levers, and turn off the machine.
2. Empty the grass basket of clippings, install the grass basket on the mower and commence the transport operation.

Checking the Operation of the Interlock Switches

Service Interval: Before each use or daily

⚠ CAUTION

If the safety interlock switches are disconnected or damaged the machine could operate unexpectedly causing personal injury.

- Do not tamper with the interlock switches.
- Check the operation of the interlock switches daily and replace any damaged switches before operating the machine.

Operator Presence Control (OPC) Interlock

1. Push the kickstand down with your foot and pull up on the handle support until the kickstand has rotated forward, over center.
2. With the OPC released, attempt to engage the traction lever (Figure 19). The traction lever should not engage. If the traction lever engages, the interlock system needs service. Correct the problem before operating.
3. With the OPC pressed and the traction lever engaged, release the OPC (Figure 20). The traction lever should disengage. If the traction lever does not disengage, the interlock system needs service. Correct the problem before operating.
4. With the OPC pressed and the shift lever moved to the left, engage the traction and reel drive, release the OPC (Figure 20). The traction lever should disengage. If the traction lever does not disengage, the interlock system needs service. Correct the problem before operating. Refer to [Adjusting the Reel Control \(page 35\)](#).
5. With the OPC pressed and the shift lever moved to the left, engage the traction and reel drive. Move the shift lever to the right to disengage the reel drive (Figure 19). The reel drive should disengage. If not, the interlock system needs service. Correct the problem before operating. Refer to [Adjusting the Reel Control \(page 35\)](#).

Traction Interlock Switch

1. Ensure that the kickstand is down.
2. Press the OPC and engage the traction lever (Figure 19)
3. Use the key switch to start the machine. The InfoCenter LCD display will light up and display a message warning that the traction lever is engaged. If this warning does not appear, the interlock switch needs service. Correct the problem before operating. Refer to [Servicing the Brake Interlock Switch \(page 33\)](#).
4. Turn off the machine and return the traction lever to neutral.

Brake Interlock Switch

1. Ensure that the kickstand is down.
2. With the machine on and the service brake engaged (not the parking brake latch) with moderate force, press the OPC and engage the traction lever (Figure 19). The motor should labor to overcome the brake without producing errors on the InfoCenter LCD display. It may display a high power consumption advisory (smaller battery with a lightning bolt). If you get any other advisory, correct the problem before operating.
3. With the machine on, engage the parking brake latch, press the OPC, and engage the traction lever (Figure 19 and Figure 20). The motor should not run and you should get an advisory on the InfoCenter panel. If not, the interlock switch needs service. Correct the problem before operating. Refer to [Servicing the Brake Interlock Switch \(page 33\)](#).
4. Turn off the machine and return the traction lever to neutral.
5. Carefully lower the machine off of the kickstand.

Lithium Ion Battery Pack Care

⚠ WARNING

The battery pack contains high voltage which could burn or electrocute you.

- Never attempt to open the battery pack.
- Do not place anything in the connector on the battery pack other than the wire harness connector that came with the product.
- Use extreme care when handling a battery pack with a cracked case.
- Only use the charger designed for the battery pack

Charging the Battery Pack

Charge the battery pack when you are finished mowing for the day to ensure that it is fully charged for the next day's mowing. Unlike other battery types, lithium ion batteries do not have a charge memory issue and do not need to be fully discharged before charging them.

Refer to the *Lithium Ion Battery Charger Operator's Manual* for detailed instructions on charging the battery pack.

If you will be storing the mower for more than 10 days, ensure that you place it on the charger and leave the charger turned on. After 10 days of inactivity, the charger will automatically switch to storage mode, during which it reduces and maintains the charge to 40% of maximum. Refer to [Storing the Machine \(page 37\)](#) for more information on storing the machine and for removing the battery from storage mode.

Shipping/Transporting the Battery Pack

The US Department of Transportation and international transportation authorities require that lithium ion batteries be transported using special packaging and only be transported by carriers certified to haul them. In the USA, you are allowed to transport the battery when it is installed on the machine as battery powered equipment, with some regulatory requirements. Contact the US Department of Transportation or the appropriate government body in your country for detailed regulations on transportation of your eFlex or eFlex battery.

For detailed information on shipping the battery pack, refer to the instructions (3373-934) included with the Battery Shipping Kit (120-4600). These instructions are available for download from www.toro.com.

Caring for the Battery Pack

As with all rechargeable batteries, lithium ion batteries have a life span during which they will hold a sufficient charge to perform the work for which they are intended. As time goes by, the total amount of work the battery will be able to complete on a single charge will gradually diminish. The following table lists the approximate expected work that the machine should be capable of over the first five years of use:

Year	Area Cut Per Full Charge
1	45,600 ft ² (4240 m ²)
2	43,800 ft ² (4070 m ²)
3	42,000 ft ² (3900 m ²)
4	40,800 ft ² (3790 m ²)
5	39,000 ft ² (3600 m ²)

Note: Your results may vary depending on the distance you need to transport the machine, the contact setting of the bed knife, and other factors as discussed in this section.

To achieve maximum life and use from your battery, apply the following care guidelines:

- Do not open the battery pack. There are no user serviceable parts inside. If you open the pack you will void your warranty. The pack is protected by tamper-alerting devices.
- Store/park the machine in a clean, dry garage or storage area, **away from direct sunlight and heat sources**. Do not store it in a location where the temperature will drop below -13 degrees F (-25 degrees C) or rise above 113 degrees F (45 degrees C). **Temperatures outside of this range will damage your battery.** High temperatures during storage, especially at a high state of charge, will reduce the life of the batteries.
- When storing for more than 10 days, ensure that the machine is in a cool location, out of sunlight, and connected to the charger.
- If you are mowing in hot conditions or in sunlight, the battery may overheat. If this happens, a high temperature

alert will appear on the InfoCenter LCD display. In this condition, the machine will no longer operate with the reel engaged and the machine will slow down.

Immediately drive the machine to a cool location out of the sun, turn off the machine, and allow the battery to cool fully before resuming operation.

- Keep the battery pack cover clean. The white color reflects sunlight and slows the heat build up in the battery pack. A dirty cover will increase the heat in the battery pack each day and will reduce the energy capacity.
- Adjust the bed knife to reel contact to be as light as possible. This will reduce the power needed to run the reel and increase the amount of work the machine will perform on each charge.

Using the InfoCenter LCD Display

The InfoCenter LCD display shows information about your machine such the current battery charge, the speed, and various diagnostics and other information about the machine and the battery pack. [Figure 31](#) illustrates the InfoCenter and the main information screen.

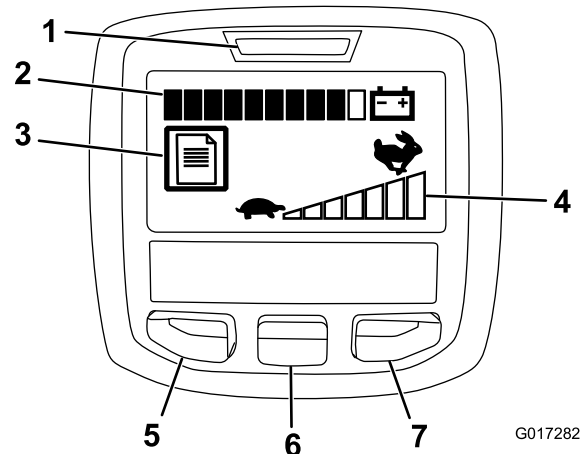

Figure 31

- | | |
|--------------------------------|----------------------------|
| 1. Power light/fault indicator | 5. Menu access/back button |
| 2. Battery charge indicator | 6. Down button |
| 3. Fault log indicator | 7. Right button |
| 4. Speed control setting | |

- Power light/fault indicator—illuminates when you turn the machine on. You can return the key to the Run position when this light illuminates. This light also blinks when there is a machine fault.
- Battery charge indicator—when the battery has a full charge, all of the boxes in the indicator will be filled in with black. As power is used, boxes will be filled with white starting from the right and proceeding to the left as the battery drains. When only one box is still black, the battery pack is almost out of power and you should immediately proceed to charge the battery.

- Fault log indicator—this icon indicates that there is a current fault log to review.
- Speed control setting—the bars turn black from left to right the faster you set the speed control. When all bars are filled with white, the machine is at Zero speed.
- Menu access/back button—press this button to access the InfoCenter menus. You can also use it to back out of any menu you are currently using.
- Down button—use this button to scroll down menus.
- Right button—use this button to open a menu where a right arrow indicated additional content.

Note: The purpose of each button may change depending on what is required at the time. Each button will be label with an icon displaying its current function.

Using the Menus

To access the InfoCenter menu system, press the menu access button while at the main screen. This will bring you to the main menu. Refer to the following tables for a synopsis of the options available from the menus:

Main Menu	
Menu Item	Description
Faults	The Faults menu contains a list of the recent machine faults. Refer to the Service Manual or your Authorized Toro Distributor for more information on the Faults menu and the information contained there.
Service	The Service menu contains information on the machine such as hours of use and battery usage and status.
Diagnostics	The Diagnostics menu lists various states that the machine currently has. You can use this to troubleshoot certain issues as it will quickly tell you which machine controls are on and which are off.
About	The About menu lists the model number, serial number, and software version of your machine.
Settings	The Settings menu allows you to customize the InfoCenter display.

Service Menu	
Menu Item	Description
Hours	Lists the total number of hours that the machine has been turned on.
Mow Time	Lists the total number of hours that the reel has been turned on.
Power Use	Lists the instantaneous power delivered by the battery in Watts.
Battery Charge	Lists the current battery charge as a percent of capacity.
Battery Current	Lists the instantaneous current delivered by the battery in Amps.
Battery Volts	Lists the battery potential in Volts.
Energy	Lists the total energy delivered by the battery over its entire life in Watt-hours.

Diagnostics Menu	
Menu Item	Description
Key On	Indicates whether the ignition key is on or off.
Key Start	Indicates whether the ignition key is in the Start position or not..
PBrake Latch	Indicates whether the parking brake latch is on or off.
EZ Turn	Indicates whether the EZ-Turn circuit is open or closed.
Traction	Indicates whether the traction lever is on or off.
Reel Enable	Indicates whether the reel is engaged or not.
Throttle	Indicates the throttle control setting in Volts (used to calculate the target RPM).
Target RPM	Lists the desired motor RPM as indicated by the speed control setting.
Motor RPM	Lists the actual motor RPM.
12V Supply	Lists the sensor supply voltage #1 of the controller.
5V Supply	Lists the sensor supply voltage #2 of the controller.
CAN Bus	Lists the machine communication bus status.

About Menu	
Menu Item	Description
Model	Lists the model number of the machine.
SN	Lists the serial number of the machine.
S/W Rev	Lists the revision number of the machine software.

Settings Menu	
Menu Item	Description
Language	Use this setting to change the language used on the InfoCenter.
Units	Use this setting to change the units used by the InfoCenter. The menu choices are English and Metric.
LCD Backlight	Use this setting to increase or decrease the brightness of the LCD display.
LCD Contrast	Use this setting to change the contrast between the dark and light areas of the LCD display.

Note: If you inadvertently change the language or contrast to a setting where you can no longer understand or view the display, contact your Authorized Toro Distributor for assistance in resetting the display.

Releasing the Transmission

If the machine becomes disabled with the motor brake on, you can disengage the drum from the transmission to allow the machine to be maneuvered.

1. On the right rear corner of the machine, locate the traction engage/disengage lever next to the drive housing drum (Figure 32).

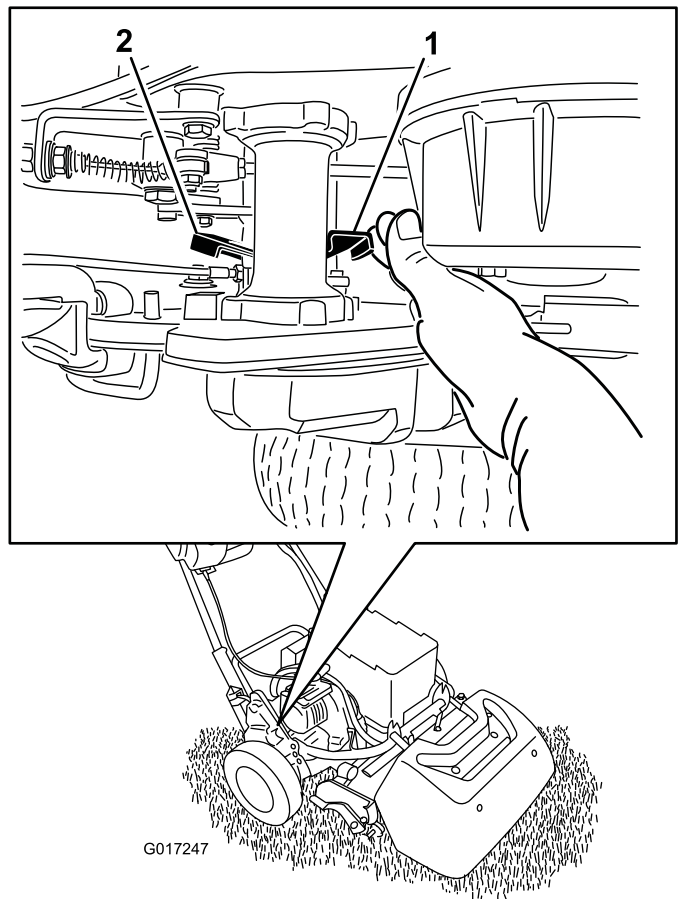

Figure 32

- | | |
|--|---|
| <ol style="list-style-type: none"> 1. Traction engage/disengage lever-engaged | <ol style="list-style-type: none"> 2. Traction engage/disengage lever-disengaged |
|--|---|

2. Rotate the lever rearward to disengage the transmission from the drum.

Important: Make sure to push the lever from the front to prevent your hand from being struck by the spring loaded lever.

3. Move the machine as needed

Important: If possible, do not tow the machine. If it is absolutely necessary, do not tow at any speed greater than 3 mph (4.8 kph); always disengage the transmission from the drum. Failing to do so will likely cause damage to the machine, especially the electrical components.

4. When finished, rotate the lever forward to engage the transmission to the drum.

Note: The service brake is still operational with the transmission disengaged from the drum.

Setting the Machine to Match Turf Conditions

Use the following table to set the machine to match turf conditions.

Bedbars: Standard and Optional (Flex/eFlex 2100 Mowers)			
Part Number	Description	Aggressiveness	Comments
106-2468-01	Non-Aggressive	Less	Red
99-3794-03	Aggressive	More	Black, Standard

Bedbars: Standard and Optional (Flex/eFlex 1800 Mowers)			
Part Number	Description	Aggressiveness	Comments
110-2282-01	Non-Aggressive	Less	Red
110-2281-03	Aggressive	More	Black, Standard

Bedknives: Standard and Optional (Flex/eFlex 2100 Mowers)			
Part Number	Description	Height-of-cut Range	Comments
115-1880	Microcut-EdgeMax	0.062 to 0.125 inches (1.6 to 3.2 mm)	Standard
93-4262	Microcut	0.062 to 0.125 inches (1.6 to 3.2 mm)	
108-4303	Extended Microcut	0.062 to 0.125 inches (1.6 to 3.2 mm)	Less aggressive
115-1881	Tournament-EdgeMax	0.125 to 0.25 inches (3.2 to 6.4 mm)	
93-4263	Tournament	0.125 to 0.25 inches (3.2 to 6.4 mm)	
108-4302	Extended Tournament	0.125 to 0.25 inches (3.2 to 6.4 mm)	Less aggressive
93-4264	Low Cut	0.25 inches (6.4 mm) and up	

Bedknives: Standard and Optional (Flex/eFlex 1800 Mowers)			
Part Number	Description	Height-of-cut Range	Comments
117-1530	Microcut-EdgeMax	0.062 to 0.125 inches (1.6 to 3.2 mm)	Standard
98-7261	Microcut	0.062 to 0.125 inches (1.6 to 3.2 mm)	
110-2300	Extended Microcut	0.062 to 0.125 inches (1.6 to 3.2 mm)	Less aggressive
98-7260	Tournament	0.125 to 0.25 inches (3.2 to 6.4 mm)	
117-1532	Tournament-EdgeMax	0.125 to 0.25 inches (3.2 to 6.4 mm)	
110-2301	Low Cut	0.25 inches (6.4 mm) and up	

Rollers (Flex/eFlex 2100 Mowers)			
Part Number	Description	Diameter/Material	Comments
04255	Narrow Wiehle	2.5 inches (6.4 cm)/Aluminum	
04256	Wide Wiehle	2.5 inches (6.4 cm)/Aluminum	More penetration
04257	Full Roller	2.5 inches (6.4 cm)/Steel	Least penetration
04258	Narrow Wiehle—Long	2.5 inches (6.4 cm)/Aluminum	More edge support; 1.7 inches (4.3 cm) longer
115-7356	Rear Roller	2.0 inches (5.1 cm)/Aluminum	Standard rear
120-9595	Rear Roller	2.0 inches (5.1 cm)/Steel	Steel rear

Rollers (Flex/eFlex 1800 Mowers)			
Part Number	Description	Diameter/Material	Comments
120-9607	Narrow Wiehle	2.5 inches (6.4 cm)/Aluminum	
120-9609	Wide Wiehle	2.5 inches (6.4 cm)/Aluminum	More penetration
120-9611	Full Roller	2.5 inches (6.4 cm)/Steel	Least penetration
121-4681	Narrow Wiehle—Long	2.5 inches (6.4 cm)/Aluminum	More edge support; 1.7 inches (4.3 cm) longer
120-9605	Rear Roller	2.0 inches (5.1 cm)/Aluminum	Standard rear

Maintenance

Note: Determine the left and right sides of the machine from the normal operating position.

Recommended Maintenance Schedule(s)

Maintenance Service Interval	Maintenance Procedure
Before each use or daily	<ul style="list-style-type: none"> Check the operation of the interlock switches.
After each use	<ul style="list-style-type: none"> Clean the machine
Every 1,000 hours	<ul style="list-style-type: none"> Inspect the reel drive belt Inspect the transmission bearings Replace as necessary
Before storage	<ul style="list-style-type: none"> Paint chipped surfaces.
Yearly	<ul style="list-style-type: none"> Grease the motor coupler.

Important: Refer to your engine operator's manual for additional maintenance procedures.

Daily Maintenance Checklist

Important: Duplicate this page for routine use.

Maintenance Check Item	For the week of:						
	Mon.	Tues.	Wed.	Thurs.	Fri.	Sat.	Sun.
Check the safety interlock operation.							
Check the parking brake operation.							
Check that pivot joints operate freely.							
Clean the battery case and motor cooling fins.							
Check for unusual operating noises.							
Check the reel-to-bedknife adjustment.							
Check the height-of-cut adjustment.							
Touch up damaged paint.							

Notation for Areas of Concern		
Inspection performed by:		
Item	Date	Information

Premaintenance Procedures

Disconnecting the Battery

Before performing maintenance on the machine, disconnect the machine from the battery pack by pulling the T-handle connector off of the main power supply connector.

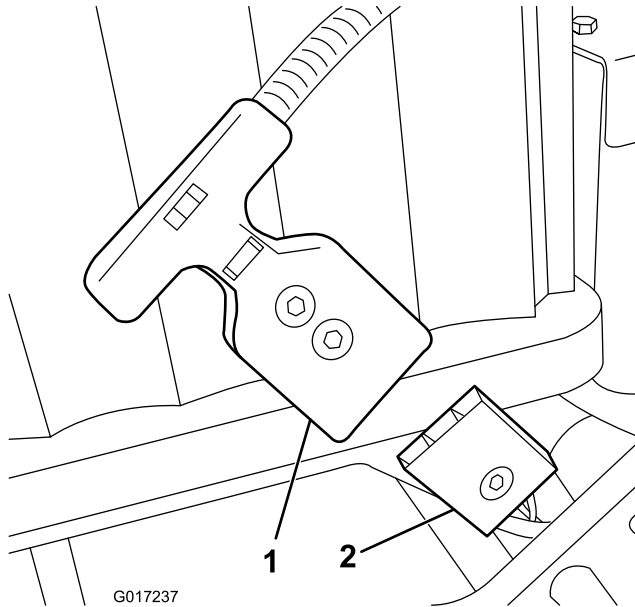

Figure 33

1. T-handle connector
2. Main power supply connector

Lubrication

Greasing the Motor Coupler

Service Interval: Yearly

Grease Type: General-purpose grease.

1. Turn off the machine and disconnect the battery pack.
2. Remove the 2 bolts securing the motor to the transmission case ([Figure 34](#)).

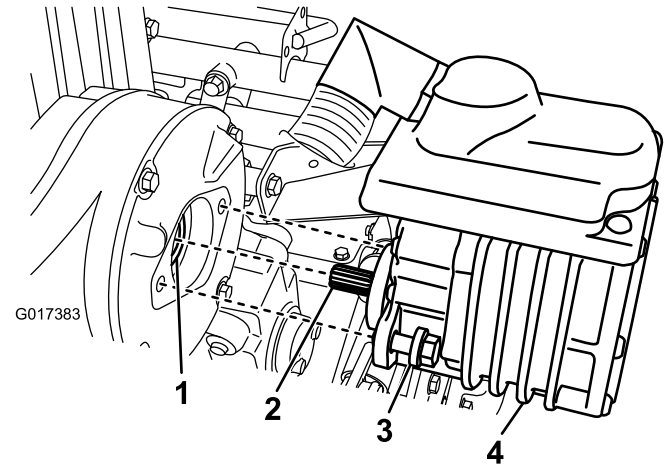

Figure 34

1. Coupler—female
2. Motor shaft
3. Bolt
4. Electric motor

3. Pull the motor out and away from the transmission case.
4. Add one to two pumps of grease from a grease gun to the female coupler in the transmission case ([Figure 34](#)).
5. Install the motor and secure it with the 2 bolts removed previously. Torque the bolts to 21 to 25 ft-lb (29 to 33 N-m).

Electrical System Maintenance

Servicing the Battery Pack

The only user serviceable parts in the battery pack are the labels and the fuse. If you attempt to open the main compartment of the battery pack you will void your warranty. If you are having problems with your battery pack, contact your Authorized Toro Distributor for help.

⚠ WARNING

The battery pack contains high voltage which could burn or electrocute you.

- Never attempt to open the battery pack.
- Do not place anything in the connector on the battery pack other than the wire harness connector that came with the product.
- Use extreme care when handling a battery pack with a cracked case.
- Only use the charger designed for the battery pack

Shipping the Battery Pack for Service

If your battery pack requires service, contact your Authorized Toro Distributor for assistance. **If you must ship the battery pack, obtain the Battery Shipping Kit, part number 120-4600.** This kit contains the proper tape, labeling, and instructions you will need to ship the battery pack.

Important: Failure to correctly pack and label the battery pack for shipping can result in large fines. Refer to the instructions included in the Battery Shipping Kit, part number 120-4600, available for free on www.Toro.com.

Replacing Fuses

If the machine will not turn on, even after charging, check the machine fuses as follows:

1. Turn off the machine and disconnect the battery pack.
2. Remove the 2 rear screws from the electrical box and loosen the 2 upper screws then remove the box cover ([Figure 35](#)).

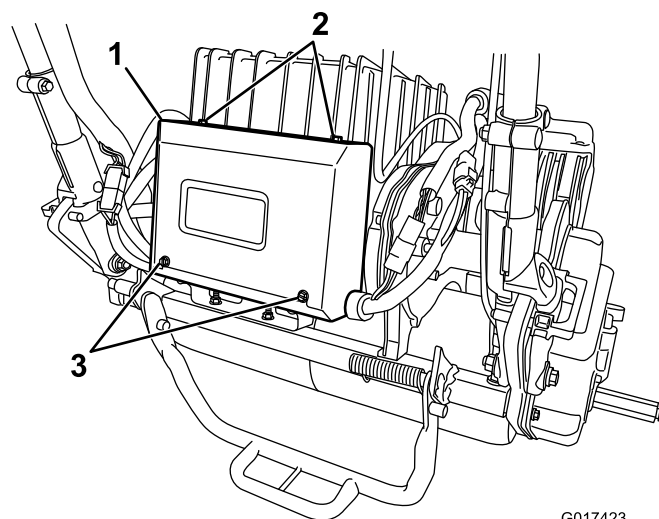

G017423

Figure 35

1. Electrical box
2. Upper screws
3. Rear screws

3. Check the fuses in the fuse block ([Figure 36](#)).

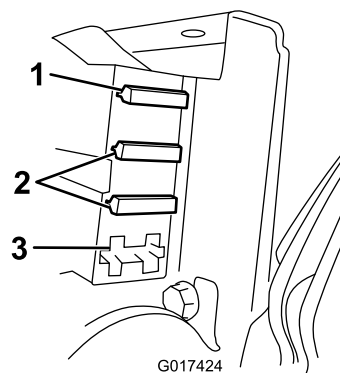

G017424

Figure 36

1. 30 amp fuse
2. 3 amp fuse
3. Open slot

- If any of the fuses are blown, replace them with a fuse of the appropriate voltage and amperage ([Figure 36](#)).

Important: All fuses on the machine are rated for 80 volts. Do not use 12 volt automotive fuses.

- If the fuses are not blown, check the battery pack fuse as follows:
 - A. Raise the battery platform; refer to [4 Installing the Battery Pack \(page 11\)](#).
 - B. Remove the fuse cover ([Figure 37](#)).

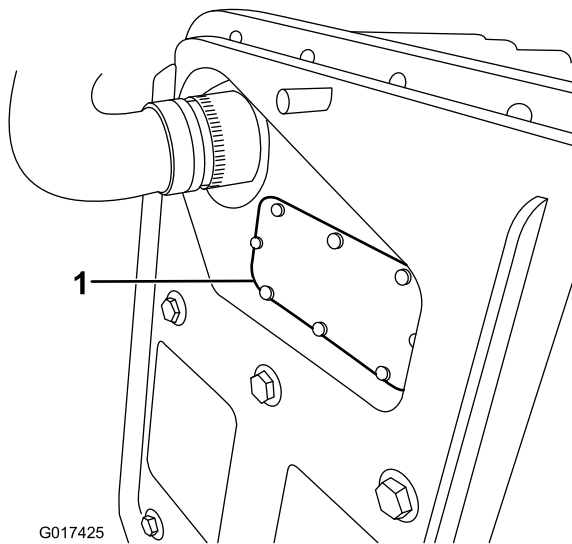

Figure 37

1. Fuse cover

- C. Check the fuse and replace it if it is blown. **Only use Toro fuse number 119-1208 to replace this fuse.** This fuse is specially designed for the battery pack and other “will fit” fuses may cause irreversible damage to the pack.
- D. Replace and secure the fuse cover. Torque the cover screw to 3 in-lb (0.34 N-m).
- E. Lower and secure the battery platform.

Servicing the Traction Interlock Switch

Use the following procedure if the traction interlock switch needs adjustment or replacement.

1. Turn off the machine and disconnect the battery pack.
2. Remove the control panel.
3. Engage the traction lever.

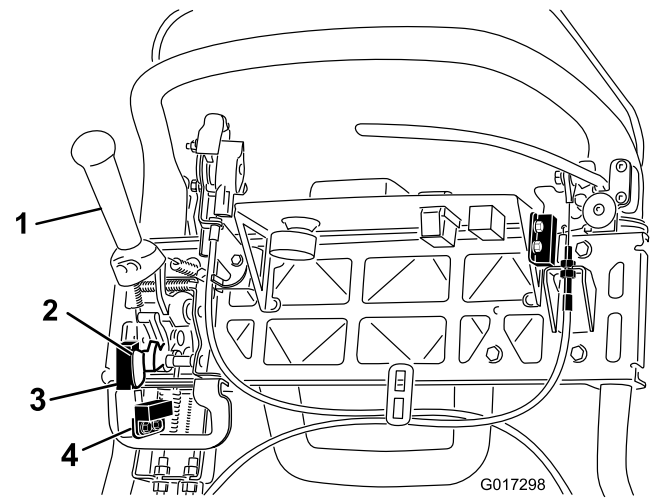

Figure 38

1. Traction lever
2. Mow sensor flag
3. Mow sensor
4. Traction interlock switch

4. Loosen the interlock switch mounting fasteners ([Figure 38](#)).
5. Place a 0.062 inch (1.6 mm) thick shim between the traction lever and the interlock switch ([Figure 38](#)).
6. Tighten the interlock switch mounting fasteners. Recheck the gap. The traction lever must not contact the switch.
7. Engage the traction lever and check the gap. The normal operating range is between .03–.12 inches (.76–3.05 mm). With the traction lever engaged, verify that the switch loses continuity. Replace the switch, if required.

Servicing the Mow Sensor

Use the following procedure if the mow sensor needs adjustment or replacement.

1. Turn off the machine and disconnect the battery pack.
2. Remove the control panel.
3. Push the traction lever to the left and engage the mower.
4. Loosen the mow sensor mounting fasteners ([Figure 38](#)).
5. Place a 0.062 inch (1.6 mm) thick shim between the mow sensor flag and the mow sensor ([Figure 38](#)).
6. Tighten the sensor mounting fasteners. Recheck the gap. The flag must not contact the sensor.
7. Engage the traction lever in mowing mode and verify that the switch loses continuity. Replace the sensor, if required.

Servicing the Brake Interlock Switch

1. Turn off the machine and disconnect the battery pack.
2. Remove the console cover.
3. Engage the service brake lever and engage the parking brake latch.
4. Loosen the interlock switch mounting fasteners (Figure 39).

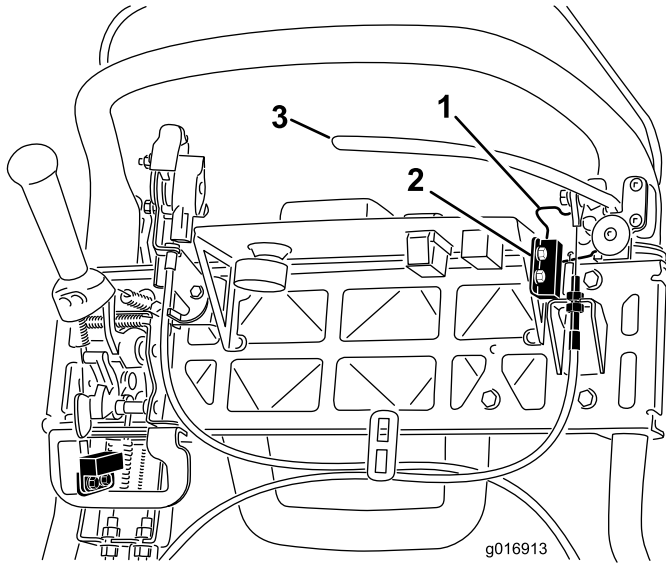

Figure 39

1. Parking brake latch
2. Interlock switch
3. Service brake lever

5. Place a 0.062 inch (1.6 mm) thick shim between the parking brake latch and the interlock switch (Figure 39).
6. Tighten interlock switch mounting fasteners. Recheck gap. The latch must not contact the switch.
7. Engage the brake lever and rotate the latch. Verify that the switch loses continuity. Replace the switch, if required.

Brake Maintenance

Adjusting the Service/Parking Brake

If the service/parking brake slips when operated, an adjustment to the cable is required.

1. Turn off the machine and disconnect the battery pack.
2. Move the service/parking brake lever to the Off position.
3. Remove the console cover.
4. To increase the cable tension, loosen the upper cable jam nut and tighten the lower cable jam nut (Figure 39) until a force of 35 lb (156 N) applied to the brake lever handle, is required to release the parking brake latch. Do not over adjust or the brake band may drag.

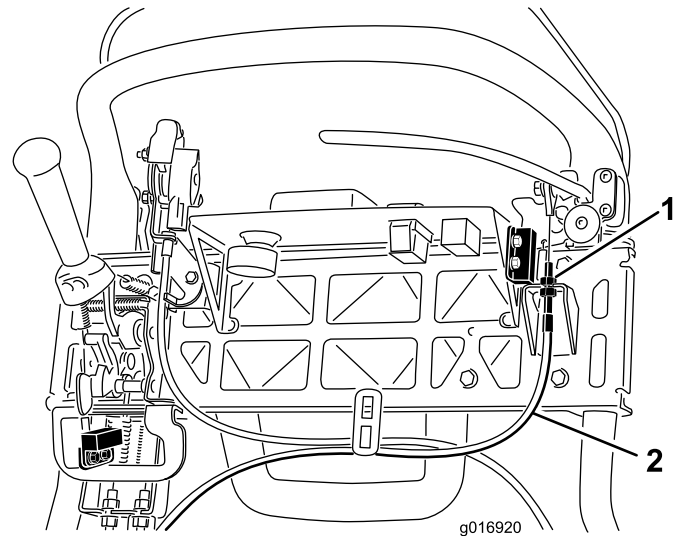

Figure 40

1. Jam nuts
2. Service brake cable

Belt Maintenance

Inspecting the Reel Drive Belt

Service Interval: Every 1,000 hours

Make sure the reel drive belt is properly tensioned to ensure proper operation of the machine and unnecessary wear.

1. Turn off the machine and disconnect the battery pack.
2. Loosen the flange bolt securing the belt cover and remove the belt cover to expose the belt (Figure 41).

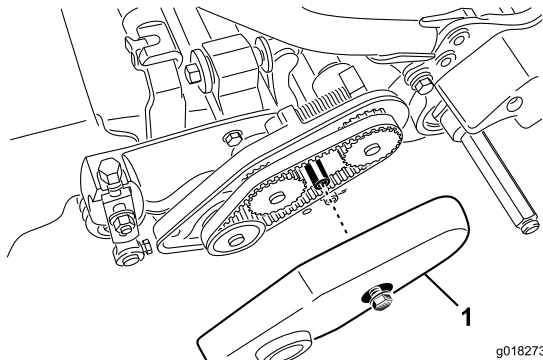

Figure 41

1. Belt cover

3. To adjust the belt tension:
 - A. Loosen the bearing housing mounting nut (Figure 42).

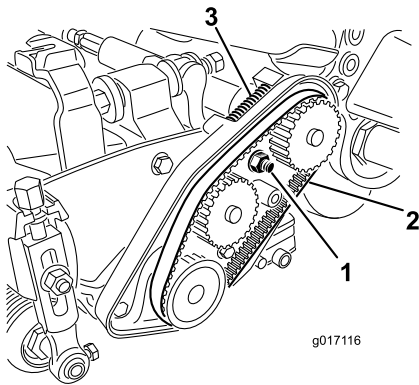

Figure 42

1. Bearing housing mounting nut
2. Reel drive belt
3. Compression spring

- B. Using a 5/8 inch (16 mm) wrench, rotate the bearing housing to make sure it operates freely.
- C. Clean any debris from inside the belt compartment and from around the compression spring (Figure 42).
- D. Make sure the compression spring is applying the proper tension on the belt.

- E. Tighten the bearing housing mounting nut.
- F. Install the belt cover.

Transmission Cover Access Hole

Remove the rubber plug (Figure 43) from the hole in the front of the transmission if you need to access the reel clutch.

Important: Do not operate the machine with the rubber plug removed.

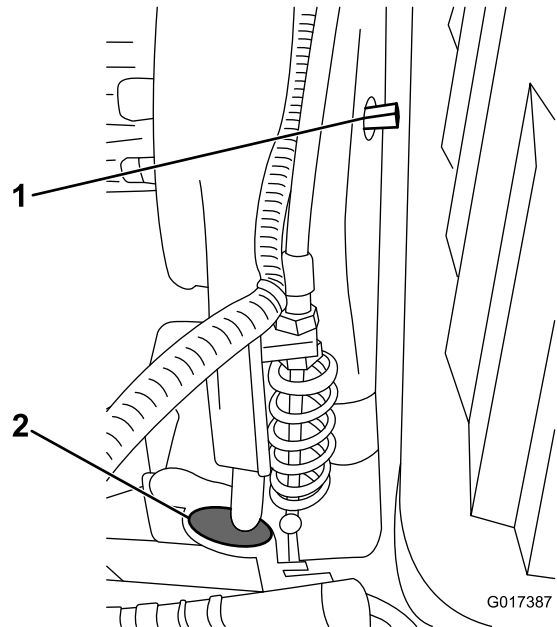

Figure 43

1. Engage/disengage shaft
2. Rubber hole plug

Transmission Belt Tensioner

The transmission belt is tensioned by a spring loaded idler pulley. If the belt tension has to be engaged/disengaged, use a 3/8 inch wrench to rotate the engage/disengage shaft (Figure 43) to the desired position. Rotating the shaft 1/4 turn clockwise will disengage the idler from the belt (Figure 44).

Note: The belt tension must be disengaged prior to removing the transmission cover.

Note: The transmission belt is properly tensioned when the alignment marks on the transmission cover and the engagement shaft are aligned.

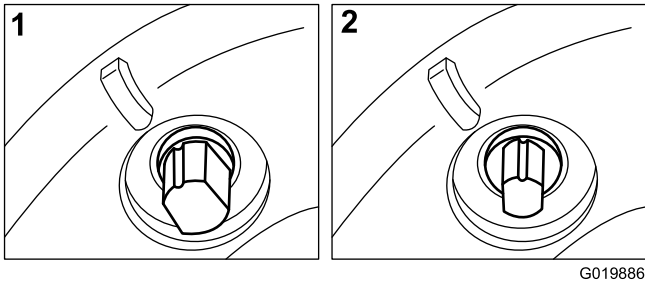

Figure 44

G019886

1. Engaged

2. Disengaged

Controls System Maintenance

Adjusting the Reel Control

If the reel control does not properly engage, an adjustment is required.

1. Turn off the machine and disconnect the battery pack.
2. Ensure that the reel control is disengaged.
3. At the transmission bulkhead, adjust the reel control cable (Figure 45), to attain a spring length of 2.78-2.85 inches (70.6-72.4 mm).

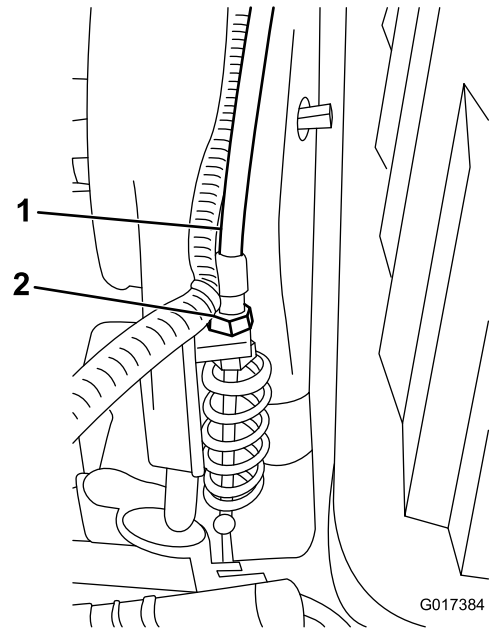

Figure 45

1. Reel control cable

2. Jam nuts

4. At the control handle bulkhead, loosen the reel control cable until there is slack in the cable (Figure 46).

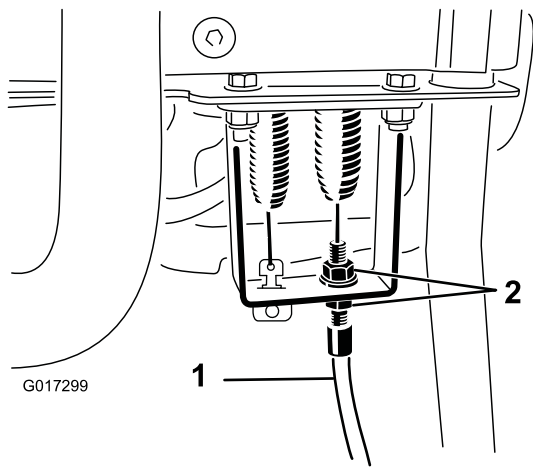

Figure 46

1. Reel control cable 2. Jam nuts

5. At the control handle bulkhead, tighten the reel control cable enough to remove the slack from the cable without extending the spring.
6. Check the operation as follows:
 - Verify that the reel clutch teeth disengage when the clutch is released and the reel clutch teeth do not bottom out when engaged.

Note: Remove the rubber plug (Figure 43) from the hole in the front of the transmission to view reel clutch.

- The reel stopping time must be less than 7 seconds with the reel to bedknife backed off.
- Refer to the Service Manual or contact your distributor for further assistance.

Cleaning

Cleaning the Machine

Service Interval: After each use

After each use, wash the machine with mild detergent and water. Do not pressure wash the machine. Avoid excessive use of water, especially near the shift lever plate, the InfoCenter, the power center, and the machine power connector. Ensure that you get the motor clean to provide proper cooling during operation. Also, keep the battery pack as clean as possible so that it stays white. This will reflect sunlight and keep the batteries from overheating in the sun.

Important: Always store/park the machine out of direct sunlight as heating from the sun will reduce the life span of the battery pack.

Storage

Storing the Machine

1. Clean the machine.

Important: You can wash the machine with mild detergent and water. Do not pressure wash the machine. Avoid excessive use of water, especially near the shift lever plate, the InfoCenter, the power center, and the machine power connector.

2. Store the machine in a cool, clean, dry garage or storage area, **away from direct sunlight**. Do not store it in a location where the temperature will drop below -13 degrees F (-25 degrees C) or rise above 113 degrees F (45 degrees C). **Temperatures outside of this range will damage your battery.**

Important: The temperature that the battery pack is stored at will affect its long term life. Storage for long periods of time at high temperatures will reduce the life of the battery pack, especially if the pack is stored with a high charge. Where possible store the machine in a cool (not below freezing) location.

3. Connect the battery to the charger and **keep the charger plugged in to a power outlet and turned on for the duration of storage.**

Important: After 10 days, the charger will enter a storage maintenance mode, adjusting the battery to a charge of 40% of maximum. This charge level during long term storage will ensure the full life of the battery. If you do not keep the battery pack on the charger and allow it to enter storage mode, the a high state of charge in the pack will shorten the life of the battery, especially if stored in warm conditions.

4. Check and tighten all bolts, nuts, and screws. Repair or replace any part that is damaged or defective.
5. Paint all scratched or bare metal surfaces. Paint is available from your Authorized Service Distributor.
6. Cover the machine to protect it and keep it clean.

Removing the Machine from Storage

1. Turn off and disconnect the charger from the machine.
2. Connect the T-handle connector to the main power connector.
3. Turn on the machine and wait 20 seconds.
4. Turn off the machine and disconnect the battery.
5. Connect the battery to the charger and turn on the charger.

The charger will enter the normal charge mode and charge the battery to full capacity.

Schematics

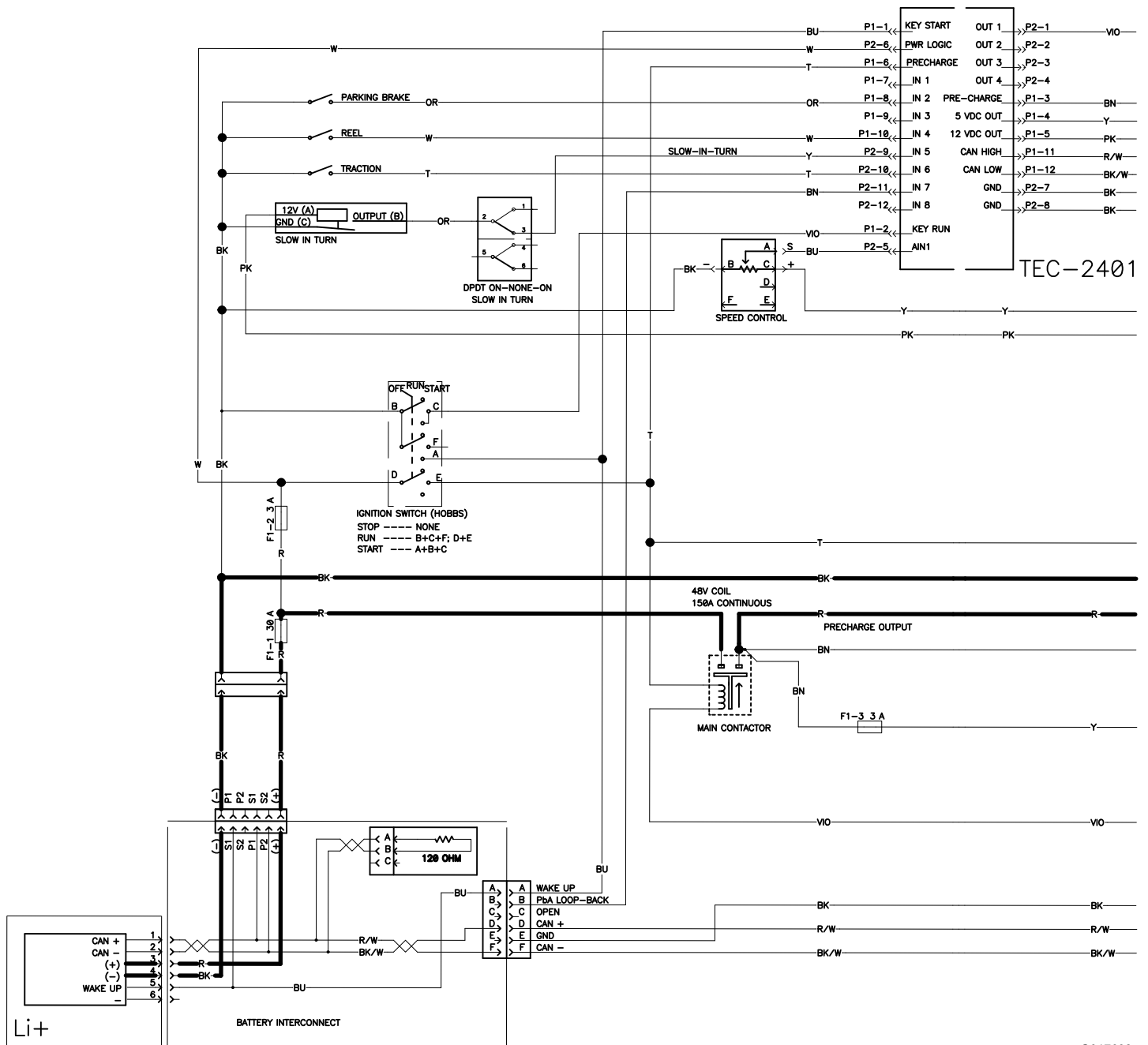

Electrical Schematic, Part 1 (Rev. A)

G017602

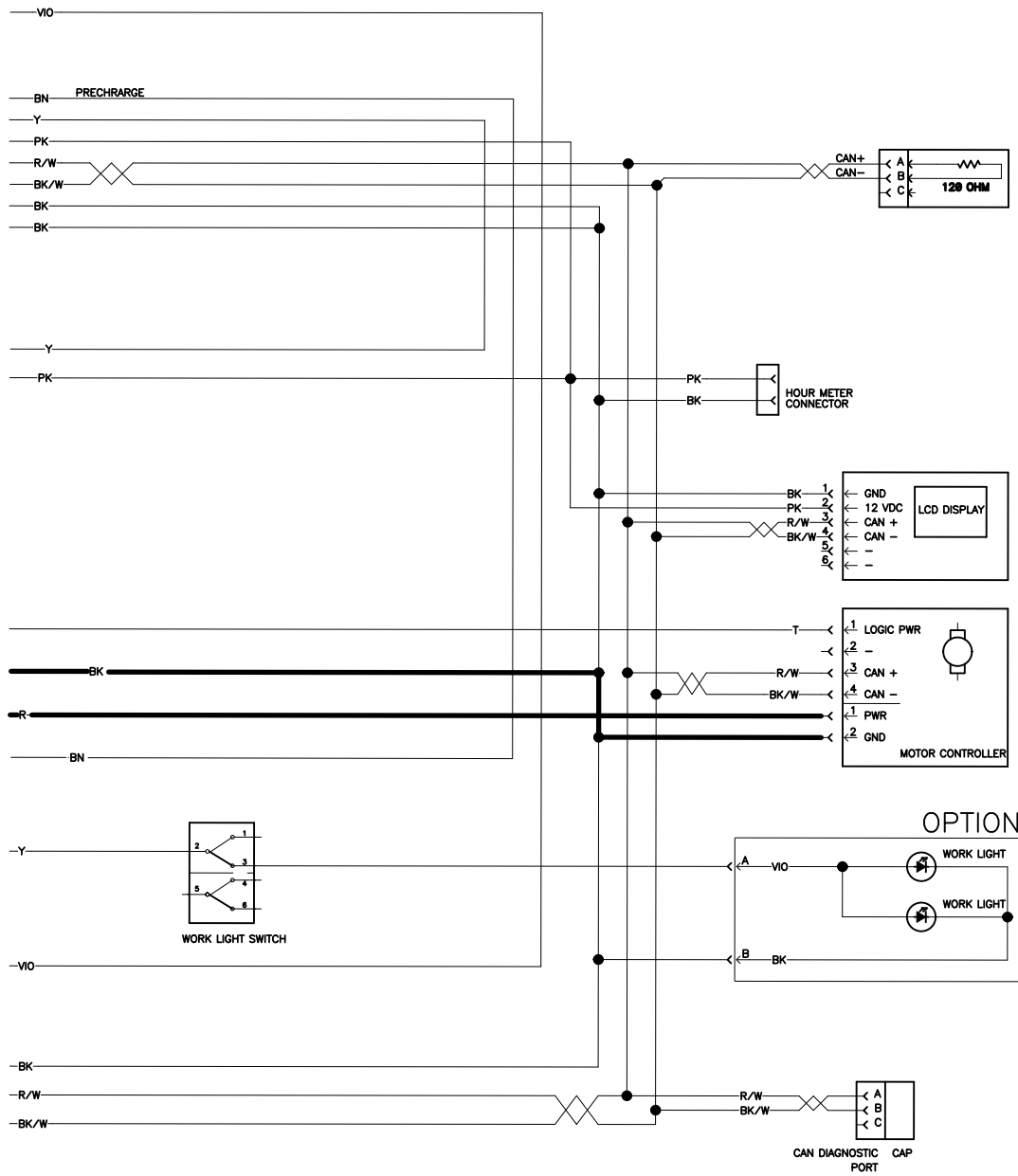

g017603

Electrical Schematic, Part 2 (Rev. A)



Battery Limited Warranty

The rechargeable Lithium-Ion battery (Model 04232) is warranted to be free from defects in materials and workmanship for a period of 5 years or 1,925 Kilowatt Hours (kWh) of use, whichever occurs first. Over time, battery consumption reduces the amount of energy capacity (Watt-hours) available per full charge. Energy consumption varies due to operating characteristics, accessories, turf, terrain, adjustments, and temperature.

The warranty program includes two warranty coverage levels:

Warranty coverage - Tier #1: Full warranty coverage applies to the first two years (730 days) from product purchase invoice date or 820 kWh of battery output, whichever occurs first. If a warrantable failure occurs during Tier 1, Toro will replace the battery with a new or remanufactured battery at no charge to you. This includes diagnostics, labor, parts, and transportation. The replacement battery retains the remainder of the original battery warranty.

Warranty Coverage - Tier #2-7: During the remaining 3 years or 1925 kWh, whichever occurs first, a prorated "Part Only" warranty applies. This coverage excludes diagnostics, labor, and transportation. Warranty coverage is based on the table below using days in service and kWh, whichever is greater, to determine the correct Tier. If a warrantable failure occurs during tier 2-7, the prorated warranty allows replacement of a defective battery with a new battery where the customer pays only for the portion of battery energy consumed. A new replacement battery purchased with a customer contribution receives full Tier #1 warranty coverage. The new battery requires registration.

Tier selection examples:

1. A battery fails at 1400 days and 1150 kWh. Days in service = Tier #5 because 1400 days is less than 1460 days. kWh = Tier #3 because 1150 kWh is less than 1200 kWh. Select Tier #5 because 5 is greater than 3 (whichever is greater).
2. A battery fails at 900 days and 1300 kWh. Days in service = Tier #2 because 900 days is less than 910 days. kWh = Tier #4 because 1300 kWh is less than 1390 kWh. Select Tier #4 because 4 is greater than 2 (whichever is greater).

Your Toro Distributor establishes the retail cost of the battery and this cost includes the current battery cost, freight, tax, duty, and handling.

Tier	Years	Days	Total kWh Consumed	Customer Pay % Retail
1	≤2	0-730	0-820	Full Coverage
2	≤2.5	731-910	821-1010	16%
3	≤3	911-1095	1011-1200	28%
4	≤3.5	1096-1275	1201-1390	36%
5	≤4	1276-1460	1391-1570	44%
6	≤4.5	1461-1645	1571-1750	60%
7	≤5	1656-1825	1751-1925	68%



The Toro Total Coverage Guarantee

A Limited Warranty

Conditions and Products Covered

The Toro Company and its affiliate, Toro Warranty Company, pursuant to an agreement between them, jointly warrant your Toro Commercial product ("Product") to be free from defects in materials or workmanship for two years or 1500 operational hours*, whichever occurs first. This warranty is applicable to all products with the exception of Aerators (refer to separate warranty statements for these products). Where a warrantable condition exists, we will repair the Product at no cost to you including diagnostics, labor, parts, and transportation. This warranty begins on the date the Product is delivered to the original retail purchaser.

* Product equipped with an hour meter.

Instructions for Obtaining Warranty Service

You are responsible for notifying the Commercial Products Distributor or Authorized Commercial Products Dealer from whom you purchased the Product as soon as you believe a warrantable condition exists. If you need help locating a Commercial Products Distributor or Authorized Dealer, or if you have questions regarding your warranty rights or responsibilities, you may contact us at:

Toro Commercial Products Service Department
Toro Warranty Company
8111 Lyndale Avenue South
Bloomington, MN 55420-1196
952-888-8801 or 800-952-2740
E-mail: commercial.warranty@toro.com

Owner Responsibilities

As the Product owner, you are responsible for required maintenance and adjustments stated in your *Operator's Manual*. Failure to perform required maintenance and adjustments can be grounds for disallowing a warranty claim.

Items and Conditions Not Covered

Not all product failures or malfunctions that occur during the warranty period are defects in materials or workmanship. This warranty does not cover the following:

- Product failures which result from the use of non-Toro replacement parts, or from installation and use of add-on, or modified non-Toro branded accessories and products. A separate warranty may be provided by the manufacturer of these items.
- Product failures which result from failure to perform recommended maintenance and/or adjustments. Failure to properly maintain your Toro product per the Recommended Maintenance listed in the *Operator's Manual* can result in claims for warranty being denied.
- Product failures which result from operating the Product in an abusive, negligent, or reckless manner.
- Parts subject to consumption through use unless found to be defective. Examples of parts which are consumed, or used up, during normal Product operation include, but are not limited to, brake pads and linings, clutch linings, blades, reels, rollers and bearings (sealed or greasable), bed knives, spark plugs, castor wheels and bearings, tires, filters, belts, and certain sprayer components such as diaphragms, nozzles, and check valves, etc.
- Failures caused by outside influence. Conditions considered to be outside influence include, but are not limited to, weather, storage practices, contamination, use of unapproved fuels, coolants, lubricants, additives, fertilizers, water, or chemicals, etc.
- Failure or performance issues due to the use of fuels (e.g. gasoline, diesel, or biodiesel) that do not conform to their respective industry standards.

Countries Other than the United States or Canada

Customers who have purchased Toro products exported from the United States or Canada should contact their Toro Distributor (Dealer) to obtain guarantee policies for your country, province, or state. If for any reason you are dissatisfied with your Distributor's service or have difficulty obtaining guarantee information, contact the Toro importer.

- Normal noise, vibration, wear and tear, and deterioration.
- Normal "wear and tear" includes, but is not limited to, damage to seats due to wear or abrasion, worn painted surfaces, scratched decals or windows, etc.

Parts

Parts scheduled for replacement as required maintenance are warranted for the period of time up to the scheduled replacement time for that part. Parts replaced under this warranty are covered for the duration of the original product warranty and become the property of Toro. Toro will make the final decision whether to repair any existing part or assembly or replace it. Toro may use remanufactured parts for warranty repairs.

Deep Cycle and Lithium-Ion Battery Warranty:

Deep cycle and Lithium-Ion batteries have a specified total number of kilowatt-hours they can deliver during their lifetime. Operating, recharging, and maintenance techniques can extend or reduce total battery life. As the batteries in this product are consumed, the amount of useful work between charging intervals will slowly decrease until the battery is completely worn out. Replacement of worn out batteries, due to normal consumption, is the responsibility of the product owner. Battery replacement may be required during the normal product warranty period at owner's expense. Note: (Lithium-Ion battery only): A Lithium-Ion battery has a part only prorated warranty beginning year 3 through year 5 based on the time in service and kilowatt hours used. Refer to the *Operator's Manual* for additional information.

Maintenance is at Owner's Expense

Engine tune-up, lubrication, cleaning and polishing, replacement of filters, coolant, and completing recommended maintenance are some of the normal services Toro products require that are at the owner's expense.

General Conditions

Repair by an Authorized Toro Distributor or Dealer is your sole remedy under this warranty.

Neither The Toro Company nor Toro Warranty Company is liable for indirect, incidental or consequential damages in connection with the use of the Toro Products covered by this warranty, including any cost or expense of providing substitute equipment or service during reasonable periods of malfunction or non-use pending completion of repairs under this warranty. Except for the Emissions warranty referenced below, if applicable, there is no other express warranty. All implied warranties of merchantability and fitness for use are limited to the duration of this express warranty.

Some states do not allow exclusions of incidental or consequential damages, or limitations on how long an implied warranty lasts, so the above exclusions and limitations may not apply to you. This warranty gives you specific legal rights, and you may also have other rights which vary from state to state.

Note regarding engine warranty:

The Emissions Control System on your Product may be covered by a separate warranty meeting requirements established by the U.S. Environmental Protection Agency (EPA) and/or the California Air Resources Board (CARB). The hour limitations set forth above do not apply to the Emissions Control System Warranty. Refer to the Engine Emission Control Warranty Statement supplied with your product or contained in the engine manufacturer's documentation for details