



Count on it.

Parts Catalog

**Commercial Walk-Behind
Traction Unit**

18HP Pistol-Grip Hydro Drive

Model No. 30069—Serial No. 313000001 and Up



Ordering Replacement Parts

To order replacement parts, please supply the part number, the quantity, and the description of each part desired.

Understanding Reference Numbers

Each identified part in an illustration has a reference number. The reference number for a part also appears in the parts list, along with other information about the part.

This catalog uses two special reference number formats, one to indicate parts in a service assembly and another to indicate the quantity of a given part in an illustration.

Service Assembly Reference Numbers

Parts in service assemblies have reference numbers in the form a:b. The a represents the reference number of the entire service assembly and the b represents a sequential number unique to each part within the service assembly.

For example, a wheel assembly might be identified by reference number 6, the tire by 6:1, the valve by 6:2, and the wheel by 6:3. When you order the assembly identified by reference number 6, you receive all parts identified by reference numbers 6:1, 6:2, and 6:3. However, you may also order any part individually. Reference numbers of this type appear in illustration and in parts lists.

Reference Numbers Indicating Quantity

In an illustration, if a reference number indicates more than one part, the reference number has the form nX y. The n represents the quantity of the part, the X is the multiplication symbol, and the y represents the reference number.

For example, in an illustration, the reference number 2X 37 means that two of the parts identified by reference number 37 are indicated.

List of Abbreviations

AR: as required

ASM: assembly

BBC: blade brake control

BHTF: button head thread forming

CARR: carriage

CCW: counter clockwise

CW: clockwise

DEG: degrees

DPA: Dual Point Adjustment

ECM: electronic control module

EXT: external

FH: flat head

GA: gauge

HD: heavy-duty

HF: hex flange

HH: hex head

HHF: hex head flange

HHFTF: hex head flange thread forming

HJ: hex jam

HLH: hex lag head

HOC: height-of-cut

HSBH: hex socket button head

HSFH: hex socket flat head

HSH: hex socket head

HWH: hex washer head

HWHTF: hex washer head thread forming

HYD: hydraulic

LH: left hand

LP: Liquefied Petroleum Gas

LPG: Liquefied Petroleum Gas

NI: nylon insert

NPTF: national pipe thread fine

PFH: phillips flat head

PPH: phillips pan head

PPHTF: phillips pan head thread forming

PRH: phillips round head

PTH: phillips truss head

PTO: power-take-off

RH: right hand

ROPS: roll-over protection system

RRB: rear roller brush

SFH: slotted fillister head

SHH: slotted hex head

SHWH: slotted hex washer head

SPH: slotted pan head

SQH: square head

SRH: slotted round head

STD: standard

TAP: self tapping

TTH: torx truss head

Contents

Engine and Muffler Assembly	4
Muffler Shield Assembly No. 120-3238	6
Fuel System Assembly	7
Rear Wheel and Hydraulic Drive Assembly	8
Hydraulic Wheel Motor Assembly No. 1-603718	9
LH Hydraulic Pump Assembly No. 116-0942	10
RH Hydraulic Pump Assembly No. 116-0943	11
Parking Brake Assembly	12
Frame and Linkage Assembly	13
Hydraulic System Assembly	14
Control Linkage Assembly	15
Control Handle Assembly	17
Handle Decal Assembly	18
Drive Control Assembly	19
Electrical Assembly	20
Attachments and Accessories	21

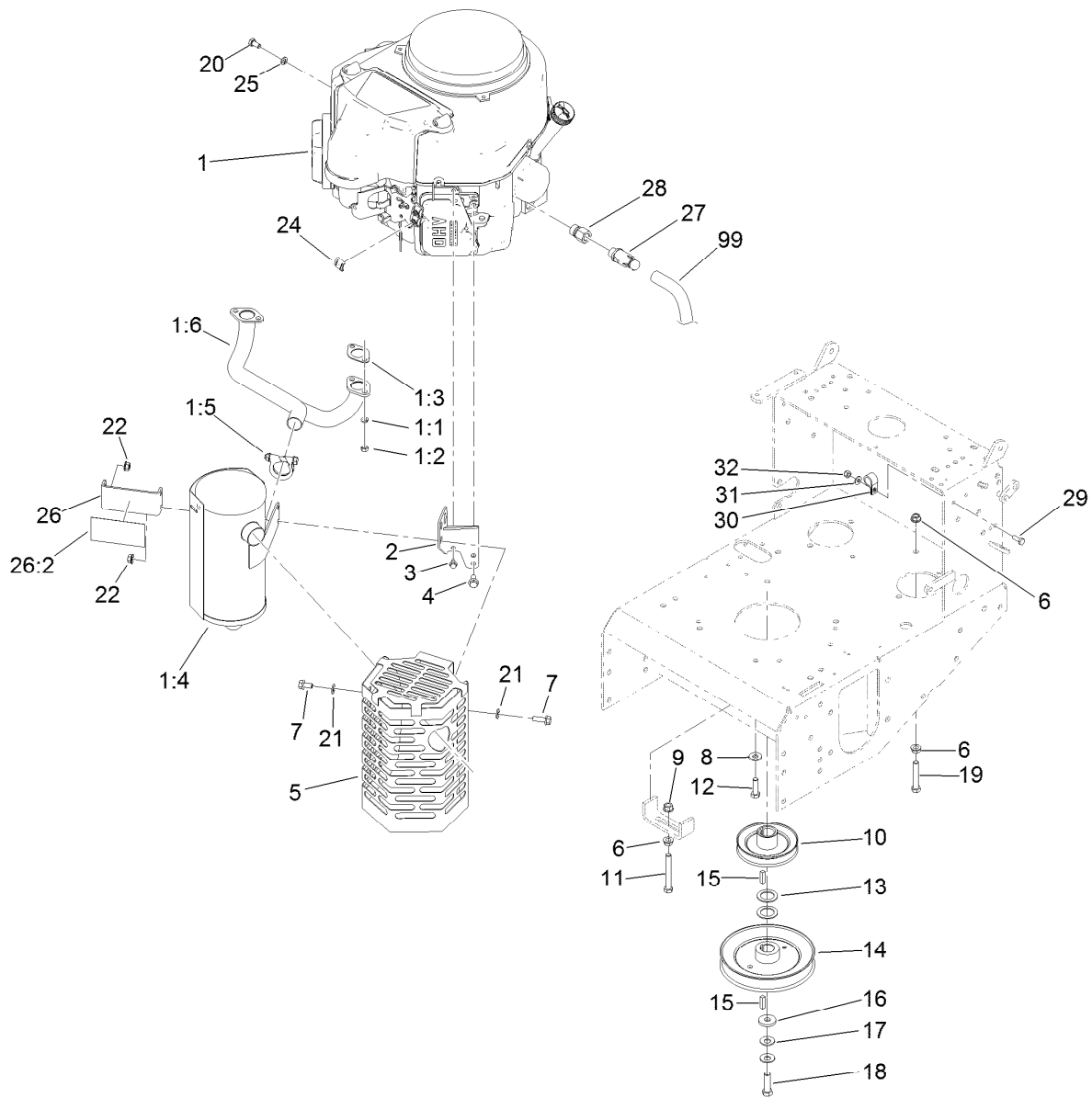

Engine and Muffler Assembly

Ref.	Part Number	Qty.	Description
1		1	Engine-Kawasaki-Fs541V ●
1:1	114-3550	4	Washer-Lock, Spring
1:2	114-3549	4	Nut
1:3	1-653313	2	Gasket-Exhaust
1:4	119-7800	1	Muffler
1:5	119-7801	1	Clamp-Muffler
1:6	119-7802	1	Manifold-Exhaust
2	117-8561-03	1	Bracket-Muffler
3	33103-012	1	Screw-HHF
4	33104-016	2	Screw-HHF
5	120-3238	1	Muffler Shield ASM
6	3290-357	11	Nut-HHF, Whiz
7	33104-025	4	Screw-HHF
8	98-5975	12	Washer-Belleville
9	32128-21	1	Nut-HF
10	1-653035	1	Pulley
11	323-14	1	Screw-HH

Ref.	Part Number	Qty.	Description
12	323-7	4	Screw-HH
13	1-523157	2	Washer-Spacer
14	110-4891	1	Pulley
15	1-807259	2	Key
16	1-373034	1	Washer
17	1-603610	2	Washer-Spring
18	116-3702	1	Screw-HH
19	323-11	1	Screw-HH
20	33114-016	1	Screw-HH
21	1-303334	4	Washer-Spring
22	117-1350	4	Nut-HF, Lock
24	81-1690	1	Clamp-Cable
25	3253-4	1	Washer-Lock
26	120-3245	1	Muffler Bracket ASM
26:2	120-3244	1	Foil-Shield, Bracket
27	120-4321	1	Valve-Drain, Oil
28	103-1966	1	Adapter
29	321-4	1	Screw-HH

● Not serviced separately

■ Obtain parts from www.kawpowerpc.com

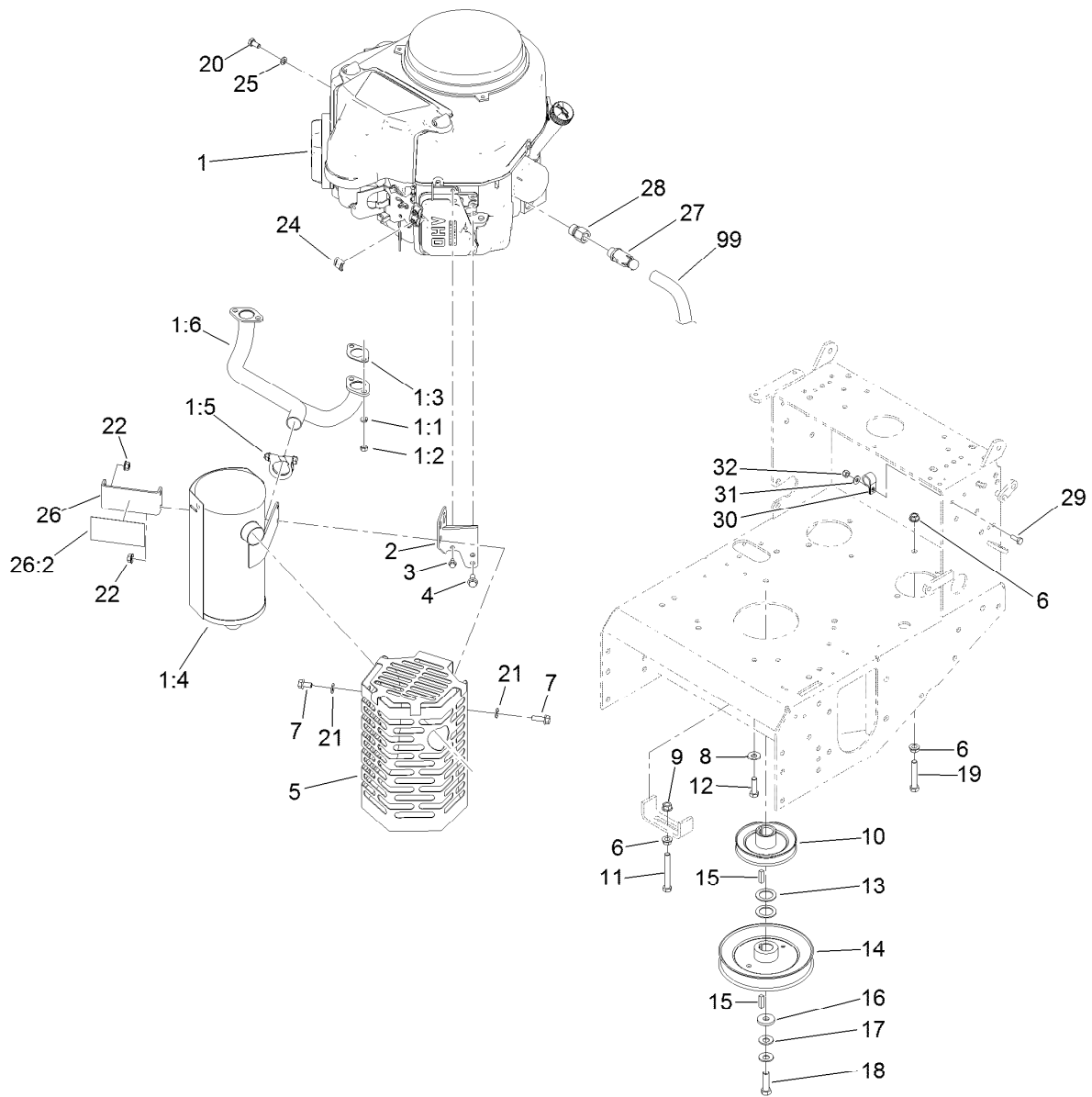

Engine and Muffler Assembly (continued)

Ref.	Part Number	Qty.	Description
30	2412-87	1	Clamp-Cable
31	3256-22	1	Washer-Flat

Ref.	Part Number	Qty.	Description
32	3296-42	1	Nut-Lock, NI
99	103-1964	1	Hose-Drain, Oil

● Not serviced separately

■ Obtain parts from www.kawpowerpc.com

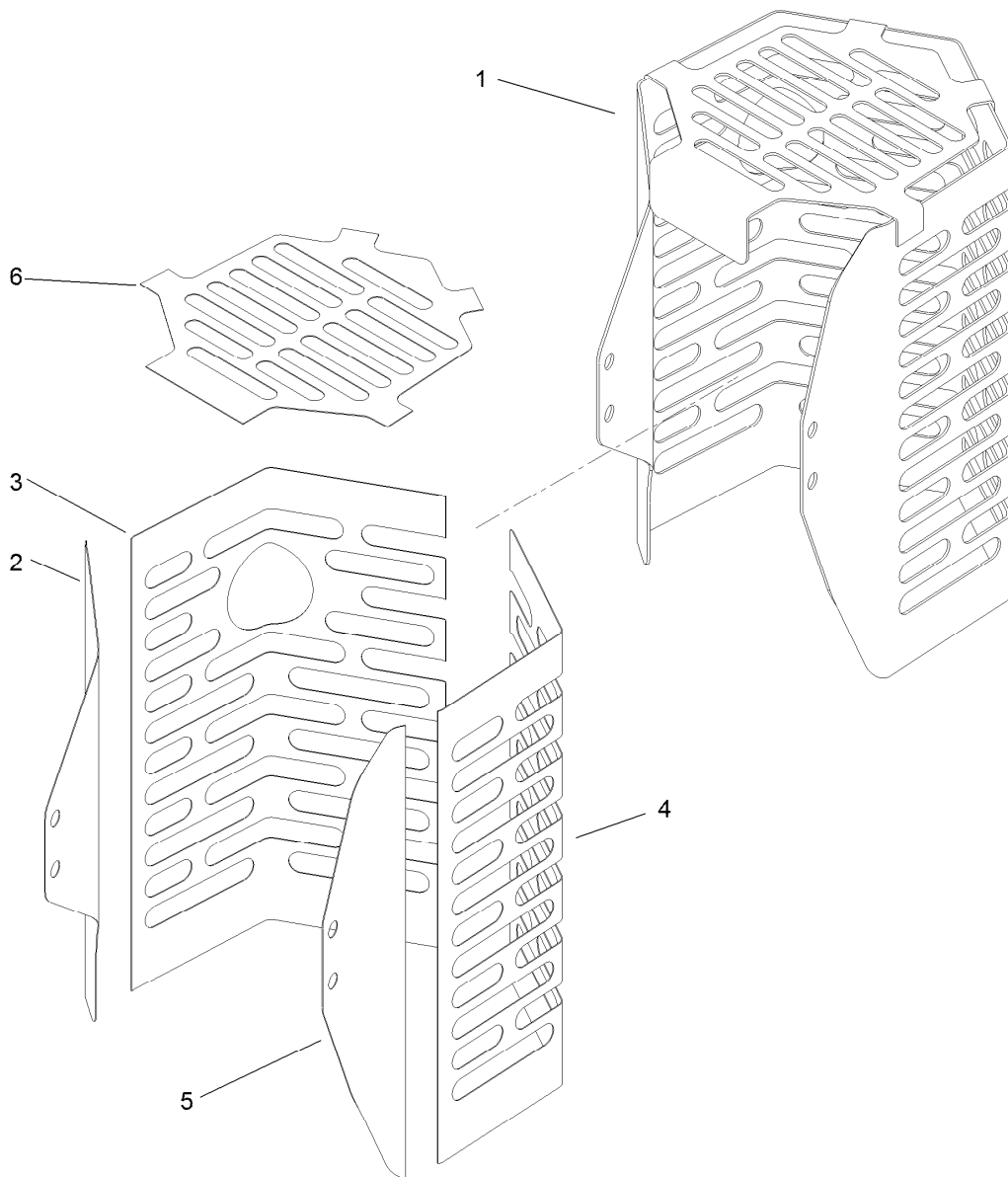

Muffler Shield Assembly No. 120-3238

<i>Ref.</i>	<i>Part Number</i>	<i>Qty.</i>	<i>Description</i>
1		1	Shield-Muffler ●
2	120-3239	1	Foil-Shield, Left
3	120-3240	1	Foil-Shield, Side
4	120-3241	1	Foil-Shield, Front
5	120-3242	1	Foil-Shield, Right
6	120-3243	1	Foil-Shield, Top

● Not serviced separately

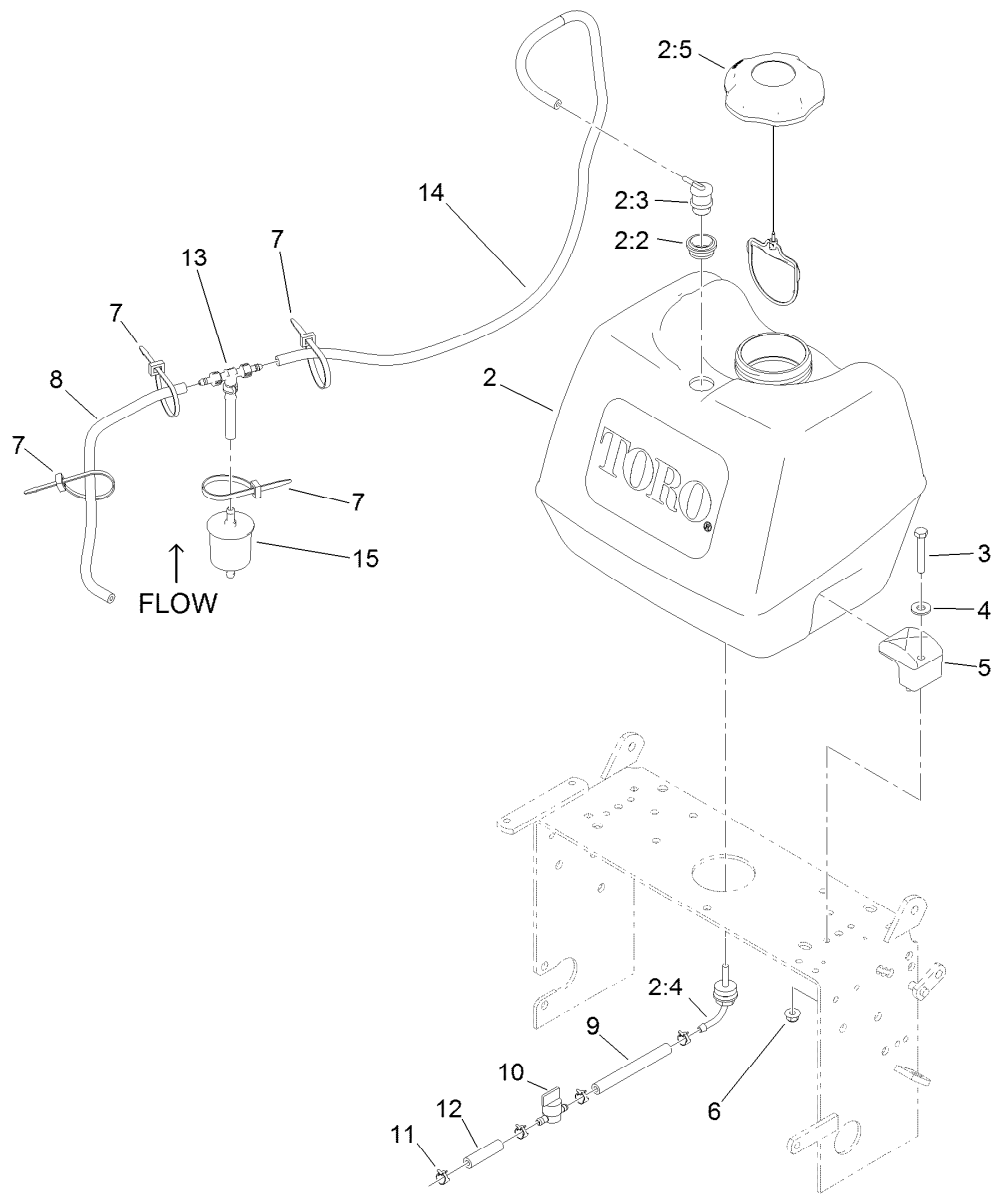

Fuel System Assembly

<i>Ref.</i>	<i>Part Number</i>	<i>Qty.</i>	<i>Description</i>	<i>Ref.</i>	<i>Part Number</i>	<i>Qty.</i>	<i>Description</i>
2	119-7899	1	Fuel Tank ASM	7	3290-378	4	Tie-Cable
2:2	114-0284	1	Grommet	8	115-7872	1	Hose-Fuel
2:3	114-0285	1	Valve-Rollover	9	109-0650	1	Hose-Fuel
2:4	103-2605	1	Fitting-Fuel, Bulkhead	10	1-603770	1	Valve-Fuel
2:5	120-5461	1	Cap-Fuel, Ratcheting	11	2412-98	4	Clamp-Hose
3	322-10	2	Screw-HH	12	99-9415	1	Hose-Fuel
4	3256-3	2	Washer-Flat	13	116-5464	1	Tee And Check
5	107-4543	2	Clamp	14	116-4346	1	Hose-Emissions
6	104-8300	2	Nut-Flange, NI	15	120-2235	1	Filter-Fuel

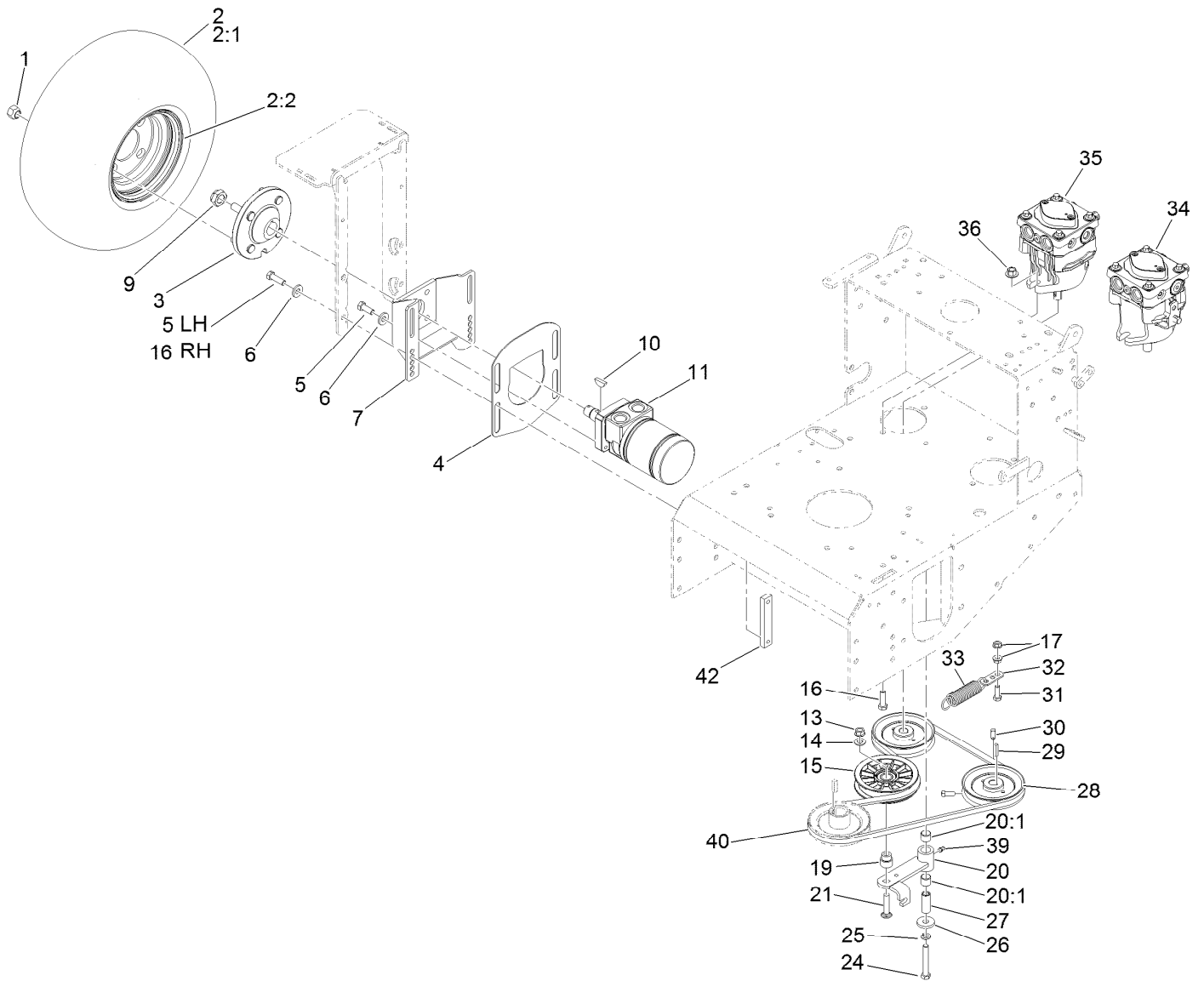

Rear Wheel and Hydraulic Drive Assembly

Ref.	Part Number	Qty.	Description	Ref.	Part Number	Qty.	Description
1	242-50	8	Nut-Lug	20:1	103-4681	2	Sleeve-Bearing
2	1-413473	2	Wheel And Tire ASM	21	3231-29	1	Screw-CARR
2:1	1-413474	1	Tire-Turfmaster	24	323-12	1	Screw-HH
2:2	1-603715	1	Wheel-Rim	25	3253-21	1	Washer-Lock
3	112-9049	2	Wheel Hub ASM	26	1-373034	1	Washer
4	115-3805-01	2	Guard-Debris	27	1-603044	1	Bushing
5	323-6	12	Screw-HH	28	1-413010	2	Sheave ASM
6	98-5975	16	Washer-Belleville	29	1-807272	2	Key
7	103-2289-01	2	Mount-Motor	30	120-6474	4	Screw-Set, SQH
9	116-2839	2	Nut-Lock	31	322-5	1	Screw-HH
10	1-807019	2	Key-Woodruff	32	1-603801	1	Anchor-Spring
11	1-603718	2	HYD Motor ASM	33	1-603402	1	Spring-Extension
13	32128-21	1	Nut-HF	34	116-0942	1	LH HYD Pump ASM
14	3256-24	1	Washer-Flat	35	116-0943	1	RH HYD Pump ASM
15	109-4077	1	Pulley-Idler, Flat	36	32128-43	4	Nut-Flange
16	323-7	4	Screw-HH	39	302-19	1	Fitting-Grease
17	32128-20	2	Nut-HF	40	106-2740	1	V-Belt
19	1-603496	1	Bushing-Idler	42	115-1023	4	Bar-Nut
20	1-602521	1	Idler Arm ASM				

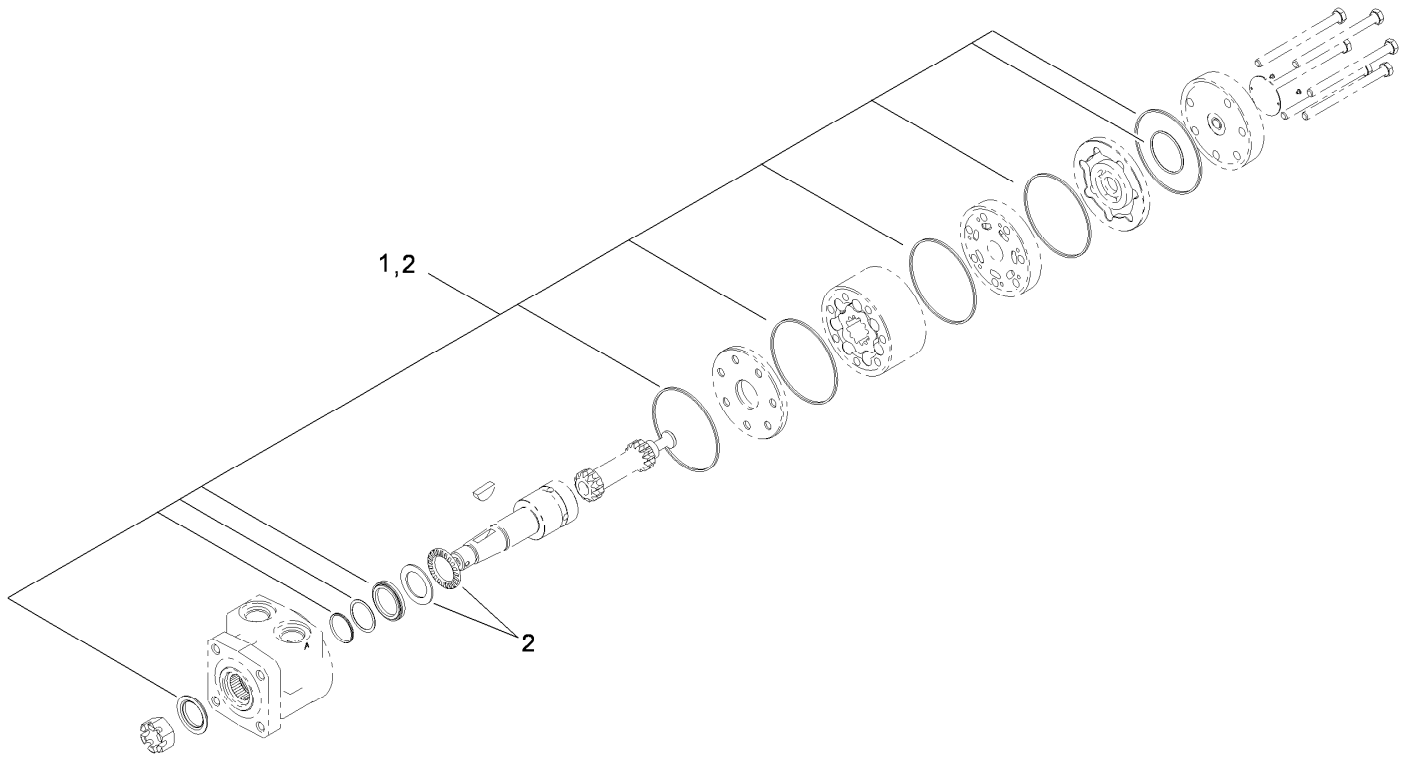

Hydraulic Wheel Motor Assembly No. 1-603718

<i>Ref.</i>	<i>Part Number</i>	<i>Qty.</i>	<i>Description</i>
1	1-000119	1	Seal Kit
2	1-000138	1	Bearing And Seal Kit

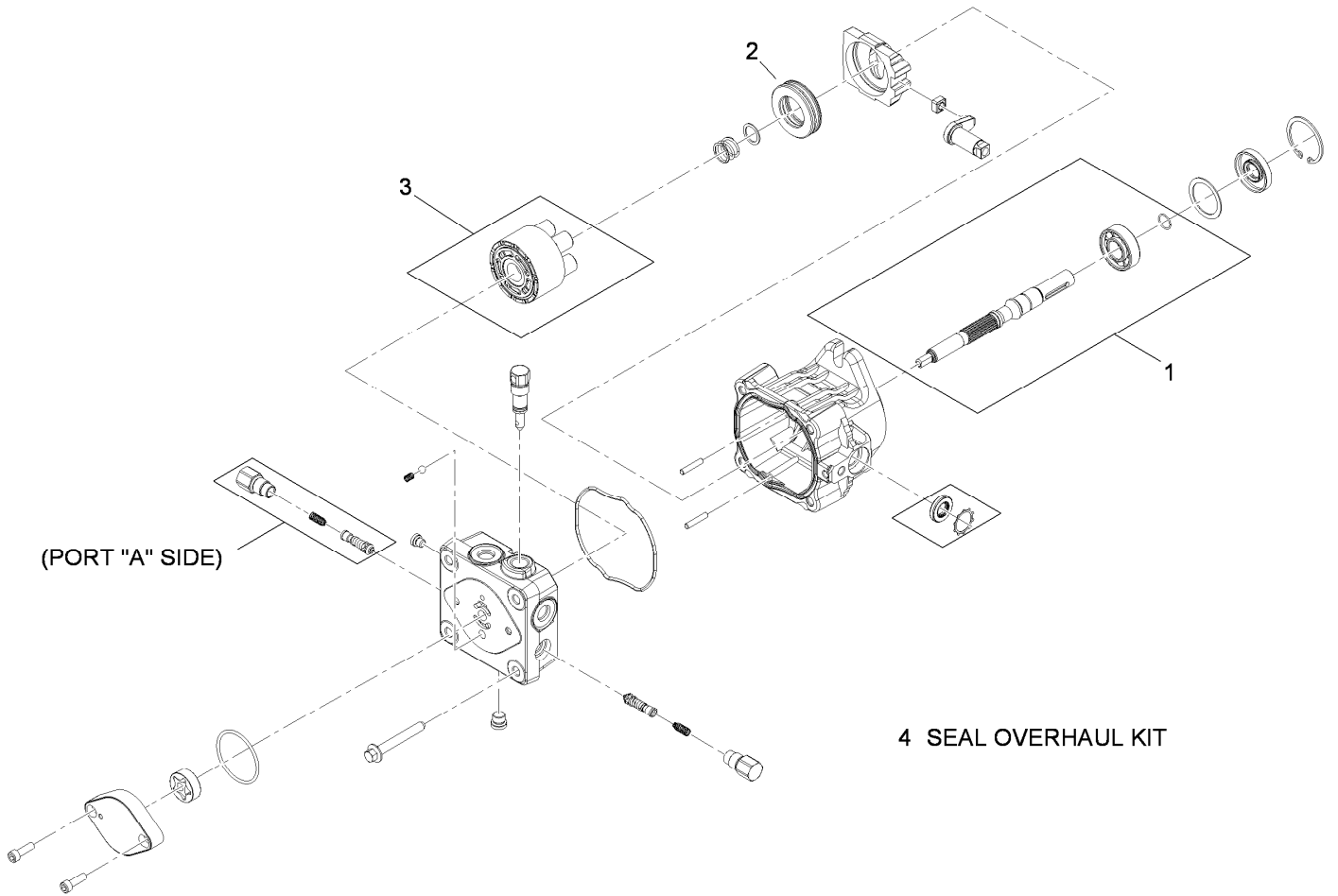

LH Hydraulic Pump Assembly No. 116-0942

<i>Ref.</i>	<i>Part Number</i>	<i>Qty.</i>	<i>Description</i>
1	103-2664	1	Input Shaft Kit
2	94-6922	1	Bearing-Thrust
3	103-2666	1	Cylinder Block Kit
4	105-6184	1	Seal Overhaul Kit

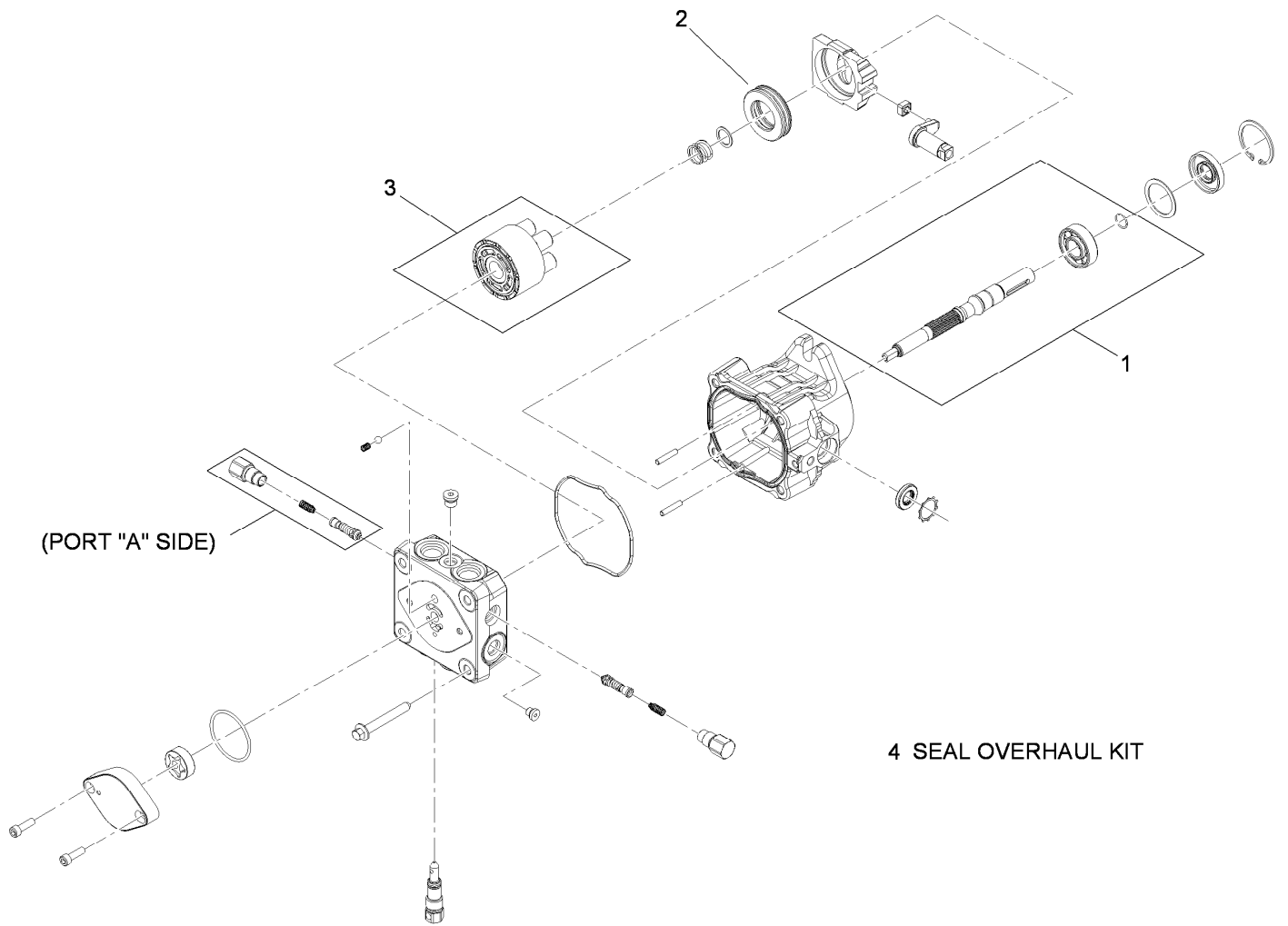

4 SEAL OVERHAUL KIT

RH Hydraulic Pump Assembly No. 116-0943

<i>Ref.</i>	<i>Part Number</i>	<i>Qty.</i>	<i>Description</i>
1	103-2664	1	Input Shaft Kit
2	94-6922	1	Bearing-Thrust
3	103-2666	1	Cylinder Block Kit
4	105-6184	1	Seal Overhaul Kit

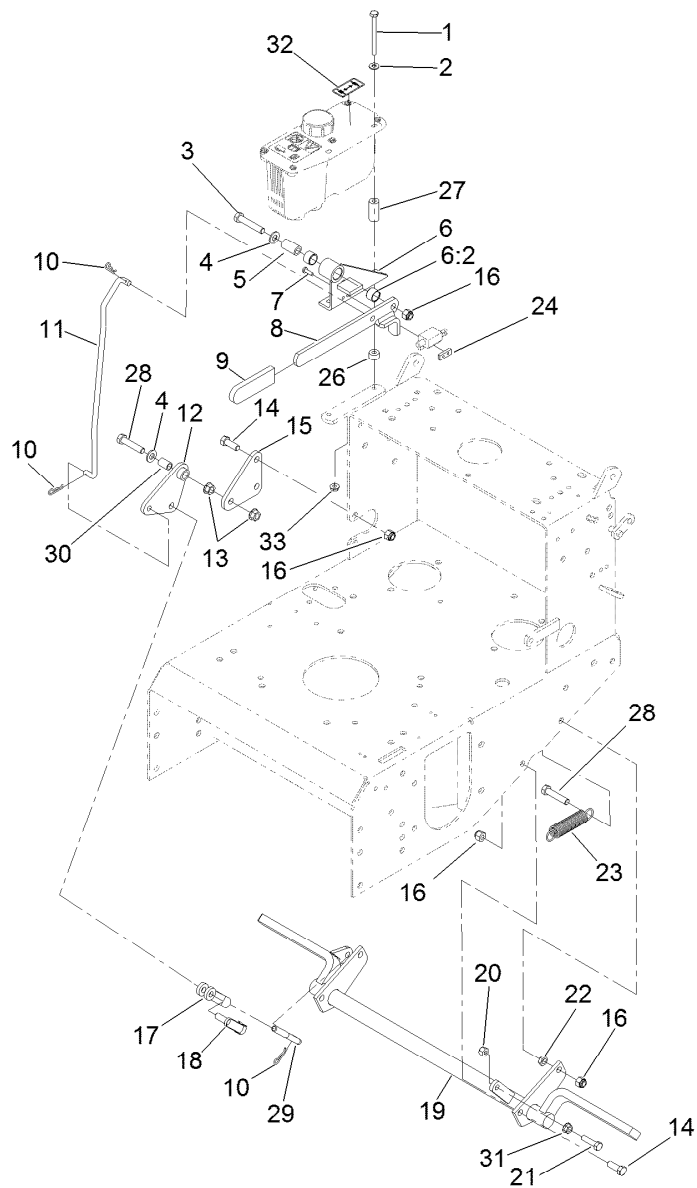

Parking Brake Assembly

Ref.	Part Number	Qty.	Description	Ref.	Part Number	Qty.	Description
1	321-23	2	Screw-HH	17	1-633131	1	Yoke-Linkage, Brake
2	3256-22	2	Washer-Flat	18	103-2399	1	Pin-Spring, Clevis
3	323-10	1	Screw-HH	19	103-2085-03	1	Brake ASM
4	3256-24	2	Washer-Flat	20	3296-29	1	Nut-Lock, NI
5	1-413344	1	Bushing-Pivot	21	116-3515	1	Screw-HH, Special
6	1-414504	1	Bracket ASM	22	3218-3	1	Nut-Jam
6:2	1-413347	2	Sleeve-Bushing	23	1-323161	1	Spring-Idler
7	3290-500	2	Screw-PPH	24	1-633181	1	Plate-Tapped
8	119-6675-03	1	Park Brake Lever	26	1-323549	2	Spacer
9	1-303020	1	Grip-Lever	27	103-2191	2	Spacer
10	1-806003	3	Pin-Cotter, Hair	28	323-9	2	Screw-HH
11	1-413496	1	Linkage-Upper	29	1-413489	1	Linkage-Lower
12	1-414508	1	Bellcrank ASM	30	1-303548	1	Bushing-Plastic
13	32128-21	2	Nut-HF	31	32128-20	1	Nut-HF
14	323-6	5	Screw-HH	32	115-1039	1	Decal-Brake, Park
15	1-413497	1	Bellcrank	33	32128-33	2	Nut-HF
16	3296-39	7	Nut-Lock, NI				

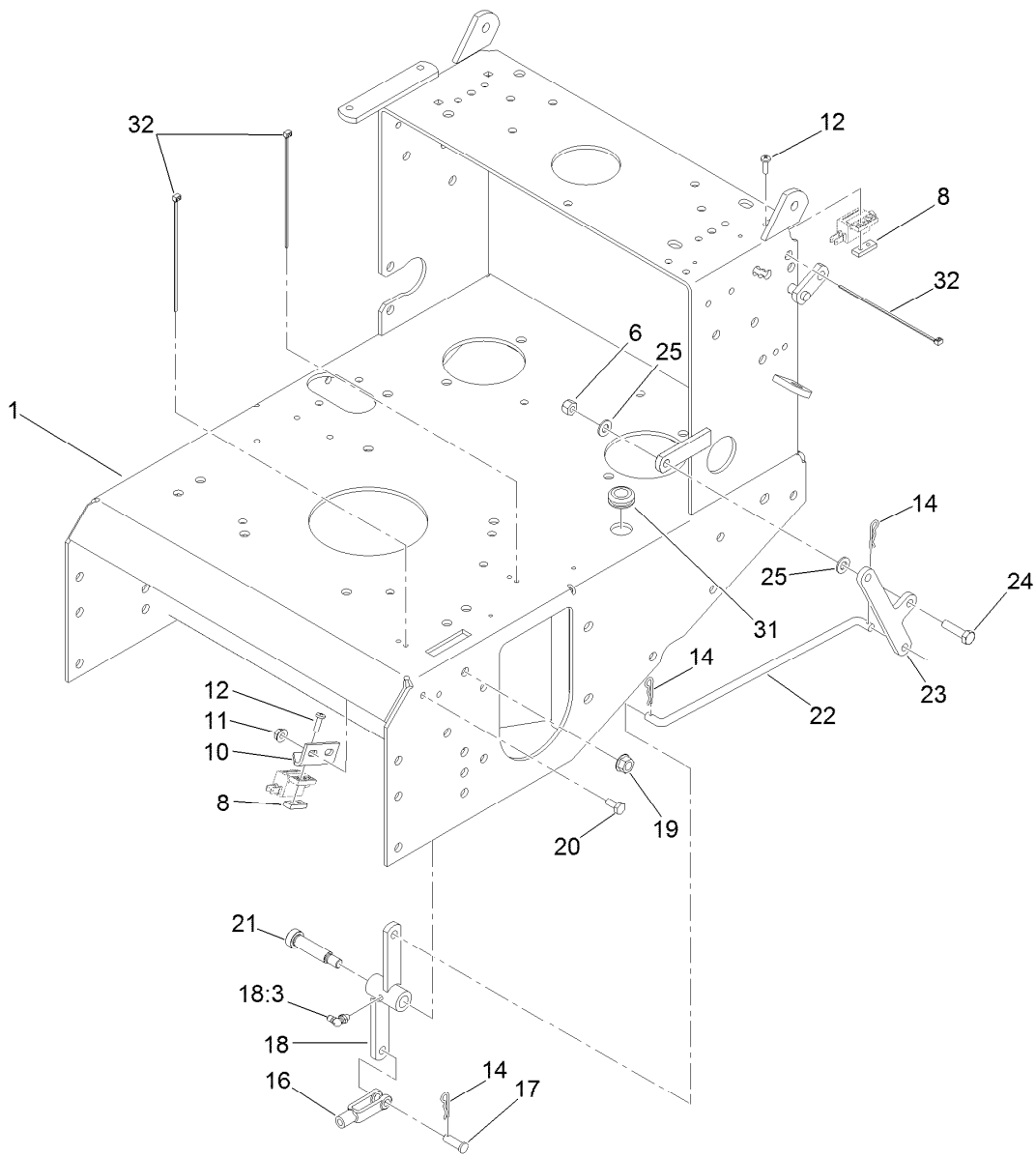

Frame and Linkage Assembly

<i>Ref.</i>	<i>Part Number</i>	<i>Qty.</i>	<i>Description</i>	<i>Ref.</i>	<i>Part Number</i>	<i>Qty.</i>	<i>Description</i>
1	116-6086-01	1	Frame	18:3	302-40	1	Fitting-Grease
6	3296-29	1	Nut-Lock, NI	19	32128-21	1	Nut-HF
8	1-633181	2	Plate-Tapped	20	321-3	2	Screw-HH
10	1-323213	1	Bracket-Switch, Blade	21	1-809062	1	Screw
11	32128-33	2	Nut-HF	22	1-323172	1	Linkage-Engage, Blade
12	3290-500	4	Screw-PPH	23	116-1737-01	1	Bellcrank
14	1-806003	3	Pin-Cotter, Hair	24	322-6	1	Screw-HH
16	1-303105	1	Yoke-Adjustable	25	3256-23	2	Washer-Flat
17	1-808280	1	Pin-Clevis	31	1-543296	1	Grommet
18	1-322108	1	Bellcrank ASM	32	1-303287	3	Tie-Cable

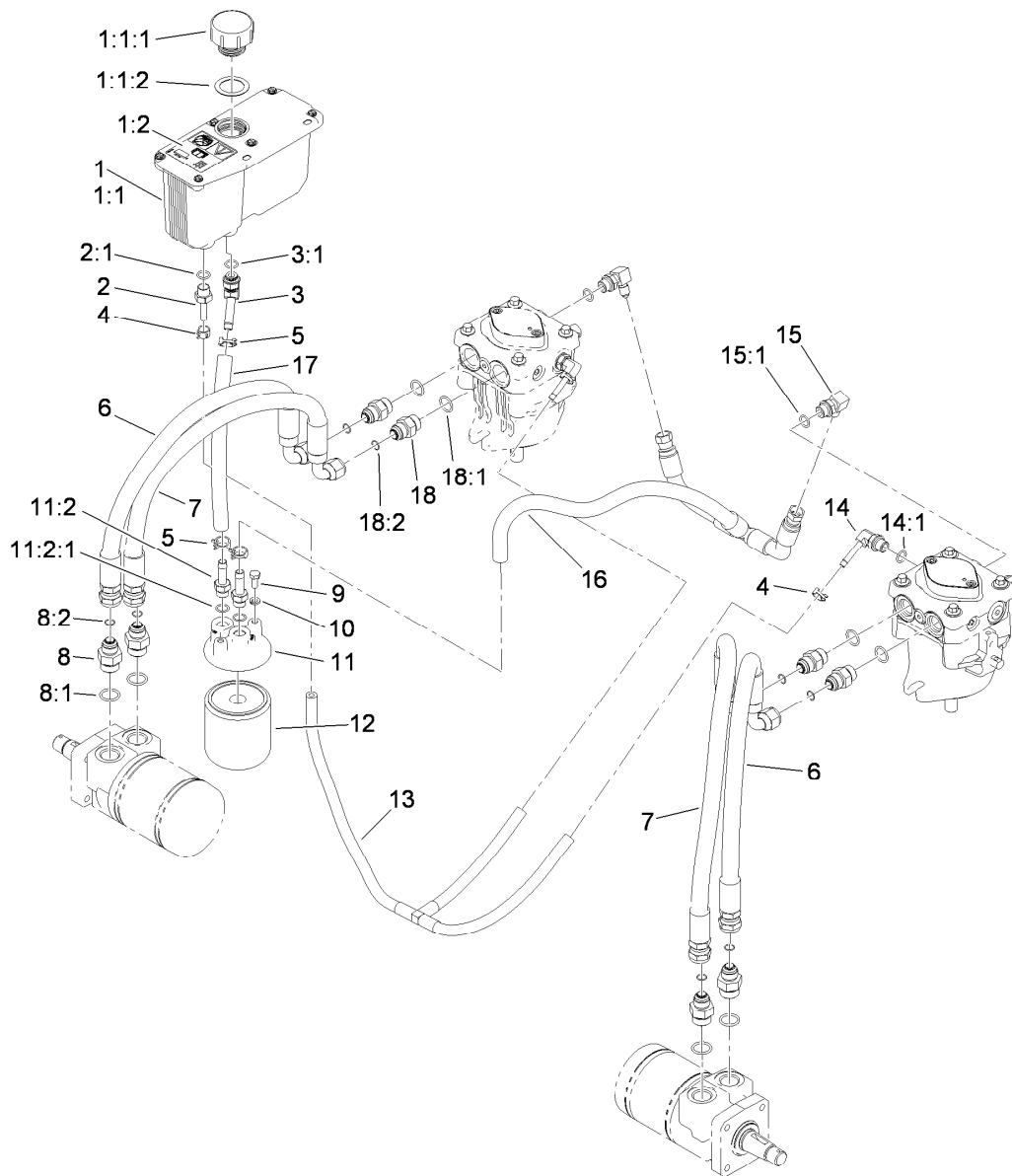

Hydraulic System Assembly

Ref.	Part Number	Qty.	Description	Ref.	Part Number	Qty.	Description
1	107-8433	1	HYD Reservoir ASM	9	321-3	2	Screw-HH
1:1		1	Reservoir-HYD ●	10	1-805004	2	Washer-Lock
1:1:1	103-1948	1	Cap-Reservoir, HYD	11	103-2889	1	Filter Head ASM
1:1:2	103-1949	1	Gasket-Cap	11:2	103-1912	2	Adapter-Straight
1:2	115-4212	1	Decal-Warning	11:2:1	237-42	1	O-Ring
2	103-1801	1	Adapter-Straight	12	1-633750	1	Filter-Oil, HYD
2:1	237-42	1	O-Ring	13	116-0918	1	Case Drain Hose ASM
3	103-1807	1	Fitting-Barbed, 45 DEG	14	103-1799	2	Elbow-90 DEG
3:1	237-42	1	O-Ring	14:1	237-42	1	O-Ring
4	103-1716	3	Clamp-Hose	15	103-1802	2	Fitting-HYD, 90 DEG
5	103-1988	3	Clamp-Hose	15:1	1-603921	1	O-Ring
6	119-7827	2	HYD Hose ASM	16	116-2123	1	Charge Hose ASM
7	119-7826	2	HYD Hose ASM	17	103-2959	1	Hose-Charge
8	1-603991	4	Fitting-Straight	18	1-603990	4	Fitting-Straight
8:1	237-80	1	O-Ring	18:1	1-603920	1	O-Ring
8:2	1-603992	1	O-Ring	18:2	1-603992	1	O-Ring

● Not serviced separately

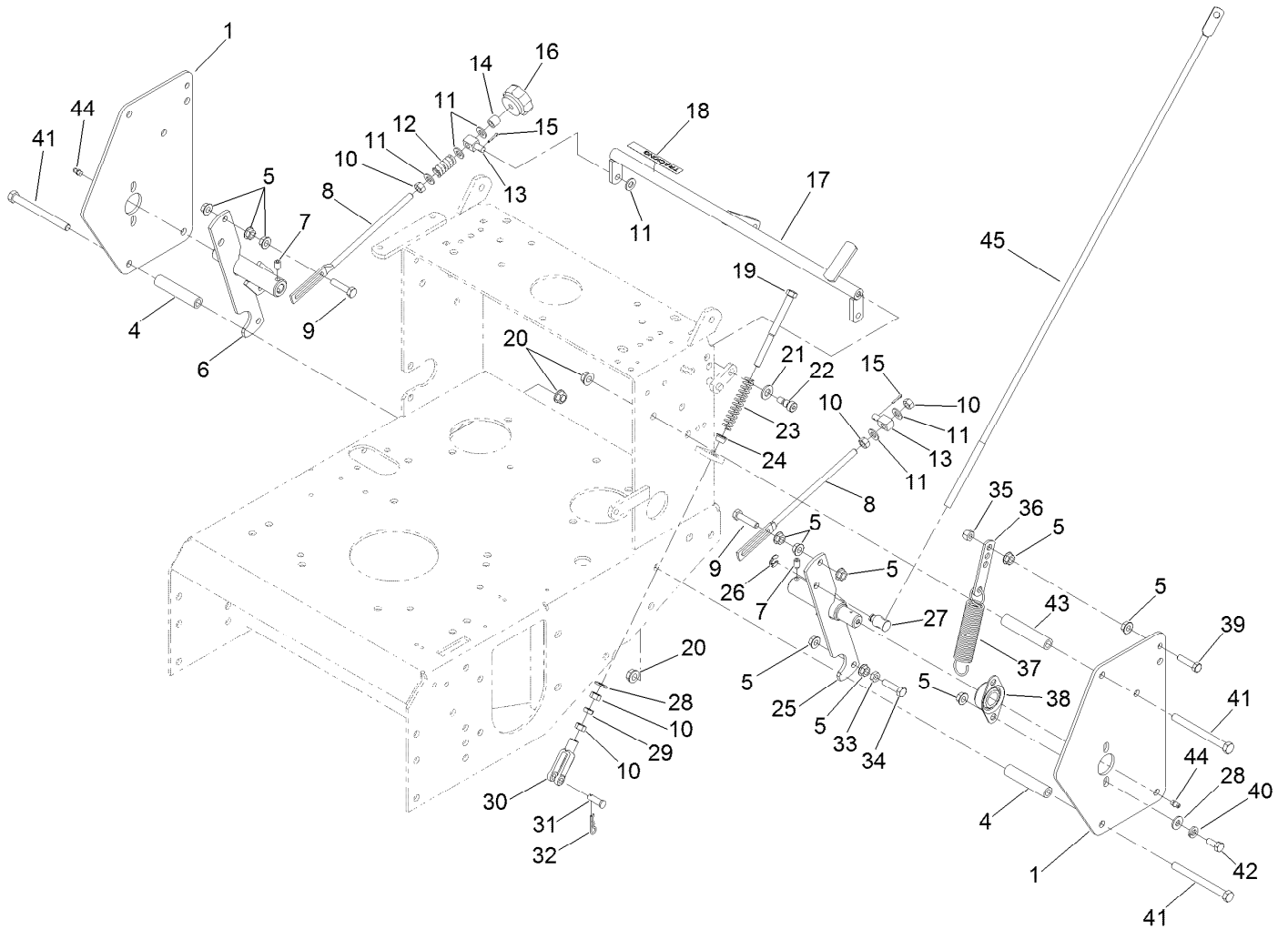

Control Linkage Assembly

Ref.	Part Number	Qty.	Description	Ref.	Part Number	Qty.	Description
1	110-4897-01	2	Shield-Control	24	1-603735	2	Bushing-Flanged
4	1-323197-01	4	Spacer-Shield	25	103-1190-01	1	Shaft-Control, LH
5	32128-20	18	Nut-HF	26	32151-47	2	Ring-Retaining
6	103-4796-01	1	Shaft-Control, RH	27	103-1235	2	Swivel-Lever, Drive
7	3246-4	2	Screw-Set	28	3256-2	6	Washer-Flat
8	1-413350	2	Link-Control, Speed	29	3220-2	2	Nut-Jam
9	1-403180	2	Screw-HH	30	1-303105	2	Yoke-Adjustable
10	3219-2	7	Nut-Hex	31	1-808280	2	Pin-Clevis
11	3256-23	7	Washer-Flat	32	1-806003	2	Pin-Cotter, Hair
12	1-323245	1	Spring-Compression	33	3218-2	2	Nut-Jam
13	1-603676	2	Swivel-Adjustable, Short	34	116-3515	2	Screw-HH, Special
14	1-603903	1	Spacer	35	3296-29	2	Nut-Lock, NI
15	3272-5	2	Pin-Cotter	36	1-613089	2	Tab-Spring, Extension
16	103-3060	1	Knob-Tracking	37	1-603693	2	Spring-Extension
17	1-412203-01	1	Crank-Control, Speed	38	1-633102	2	Bearing-Flange, Side
18	105-4109	1	Decal-Tracking	39	1-800016	2	Bolt-TAP, HH
19	1-603737	2	Bolt-Return, Neutral	40	1-805005	4	Washer-Lock
20	3290-357	8	Nut-HHF, Whiz	41	323-16	8	Screw-HH
21	3256-24	2	Washer-Flat	42	322-3	4	Screw-HH
22	1-809056	2	Screw	43	1-323195-01	4	Spacer-Shield
23	1-603807	2	Spring-Return, Neutral				

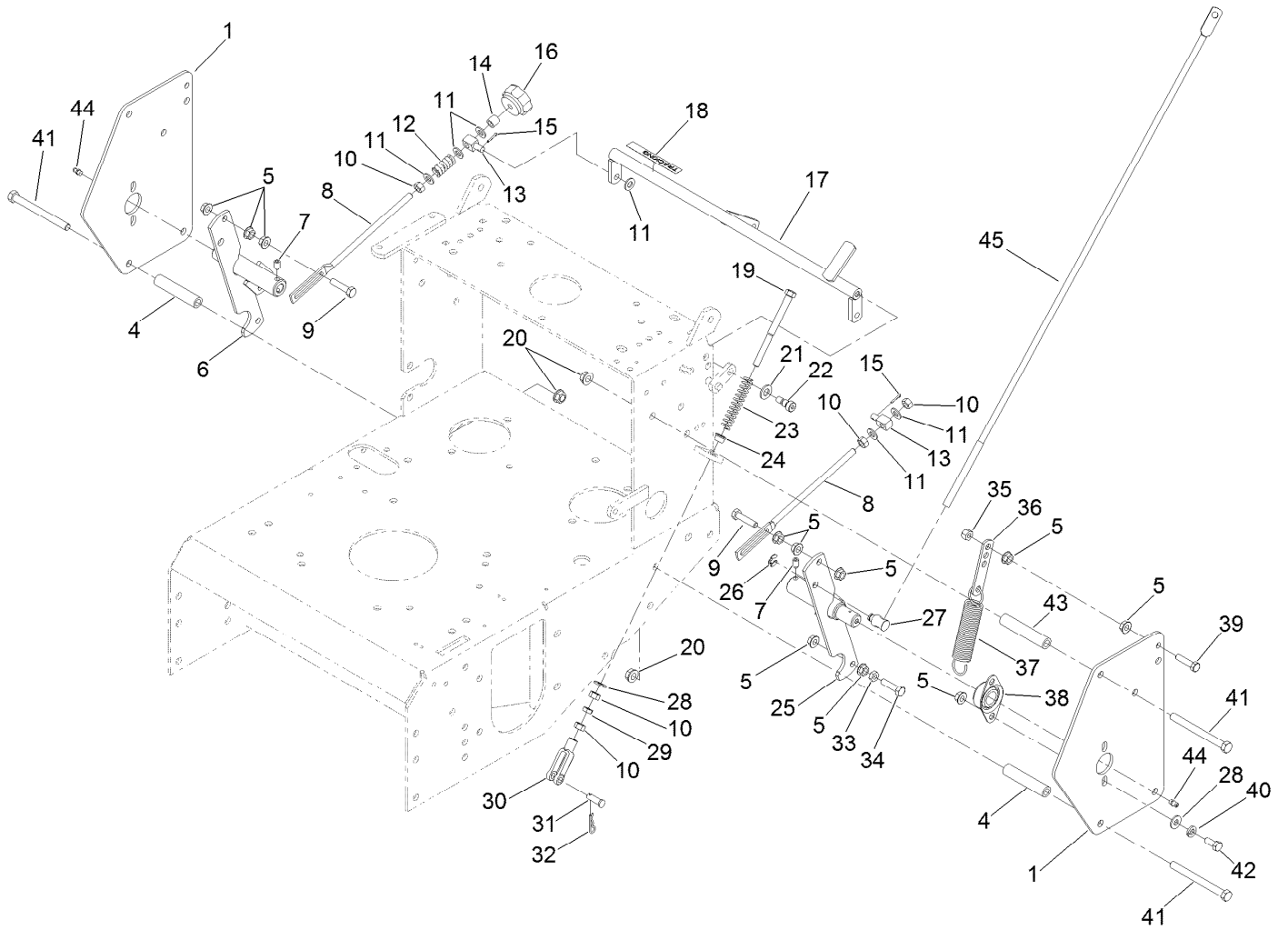

Control Linkage Assembly (continued)

<i>Ref.</i>	<i>Part Number</i>	<i>Qty.</i>	<i>Description</i>
44	302-19	2	Fitting-Grease
45	1-413219	2	Rod-Lever, Drive

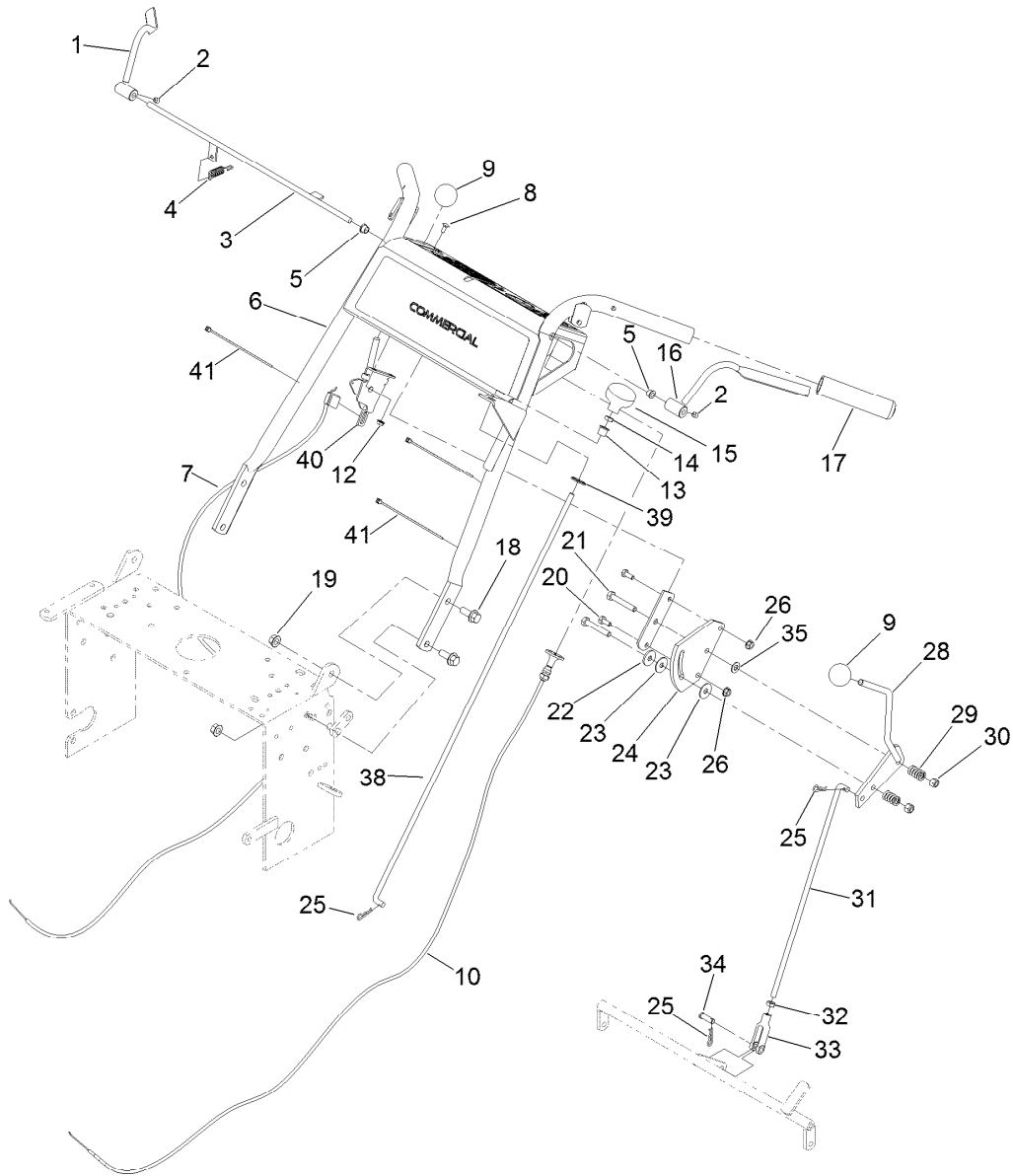

Control Handle Assembly

Ref.	Part Number	Qty.	Description
1	106-5486	1	RH Operator Presence Control Lever ASM
2	1-803322	2	Screw-Set
3	106-2717-03	1	Rod-Control, Operator Presence
4	1-303363	1	Spring-Extension
5	1-303365	2	Bushing-Nylon
6	119-6671	1	Handle ASM
7	119-6680	1	Cable-Control
8	1-807513	2	Bolt-CARR
9	1-603175	2	Knob-Ball
10	119-6679	1	Control, Choke
12	32128-17	2	Nut-Lock, Flange
13	1-323143	1	Bearing-Nylon
14	3218-2	1	Nut-Jam
15	1-323134	1	Knob-Push / Pull
16	106-5485	1	LH Operator Presence Control Lever ASM
17	104-9838	2	Grip-Foam
18	3234-11	4	Screw-HHF

Ref.	Part Number	Qty.	Description
19	32128-21	4	Nut-HF
20	321-3	2	Screw-HH
21	322-10	2	Screw-HH
22	1-603716	1	Washer-Friction
23	1-323244	2	Washer-Friction
24	1-603730	1	Plate-Lever, Shifter
25	1-806003	3	Pin-Cotter, Hair
26	32128-33	2	Nut-HF
28	106-2748	1	Lever-Shift
29	1-323245	2	Spring-Compression
30	3296-29	2	Nut-Lock, NI
31	1-323522	1	Rod-Control, Speed
32	3220-2	1	Nut-Jam
33	1-303105	1	Yoke-Adjustable
34	1-808280	1	Pin-Clevis
35	3256-23	1	Washer-Flat
38	1-323181	1	Linkage-Blade
39	1-323142	1	Nut-Push
40	110-5547	1	Lever-Control
41	1-303287	3	Tie-Cable

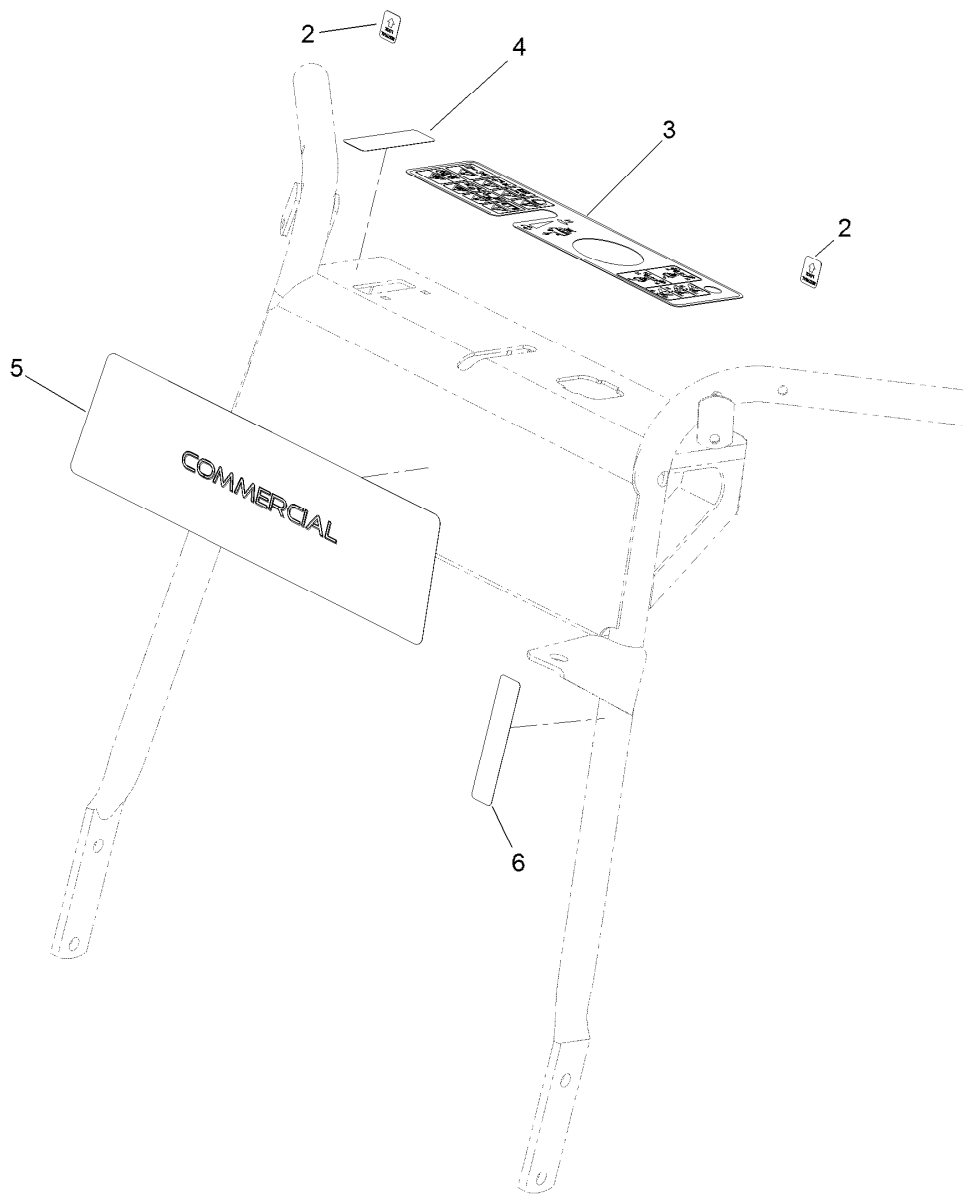

Handle Decal Assembly

<i>Ref.</i>	<i>Part Number</i>	<i>Qty.</i>	<i>Description</i>
2	105-4110	2	Decal-Lock, Neutral
3	119-6672	1	Decal-Control Panel
4	106-2733	1	Decal-Throttle
5	110-6917	1	Decal
6	95-5537	1	Decal-Engage, Deck

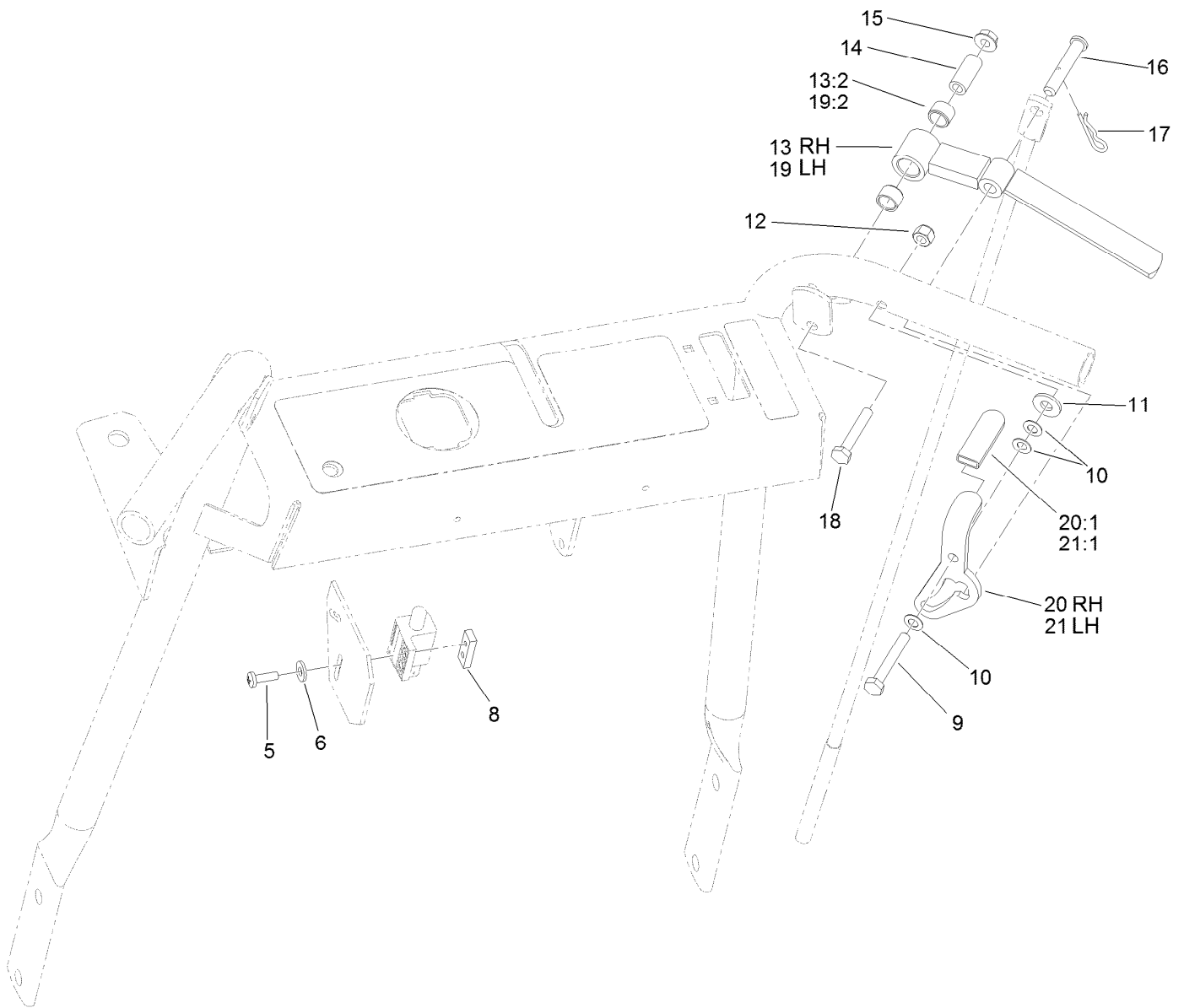

Drive Control Assembly

<i>Ref.</i>	<i>Part Number</i>	<i>Qty.</i>	<i>Description</i>	<i>Ref.</i>	<i>Part Number</i>	<i>Qty.</i>	<i>Description</i>
5	3290-500	2	Screw-PPH	15	32128-33	2	Nut-HF
6	3256-14	1	Washer-Flat	16	1-613055	2	Pin-Clevis
8	1-633181	1	Plate-Tapped	17	1-806003	2	Pin-Cotter, Hair
9	321-10	2	Screw-HH	18	321-9	2	Screw-HH
10	1-303435	6	Washer-Spring	19	103-0218	1	LH Drive Lever ASM
11	3256-2	2	Washer-Flat	19:2	1-413152	2	Bushing-Sleeve
12	3296-42	2	Nut-Lock, NI	20	1-612168	1	RH Latch And Grip ASM
13	103-0219	1	RH Drive Lever ASM	20:1	1-303019	1	Grip-Latch
13:2	1-413152	2	Bushing-Sleeve	21	1-612167	1	LH Latch Grip ASM
14	1-603749	2	Bushing-Lever, Drive	21:1	1-303019	1	Grip-Latch

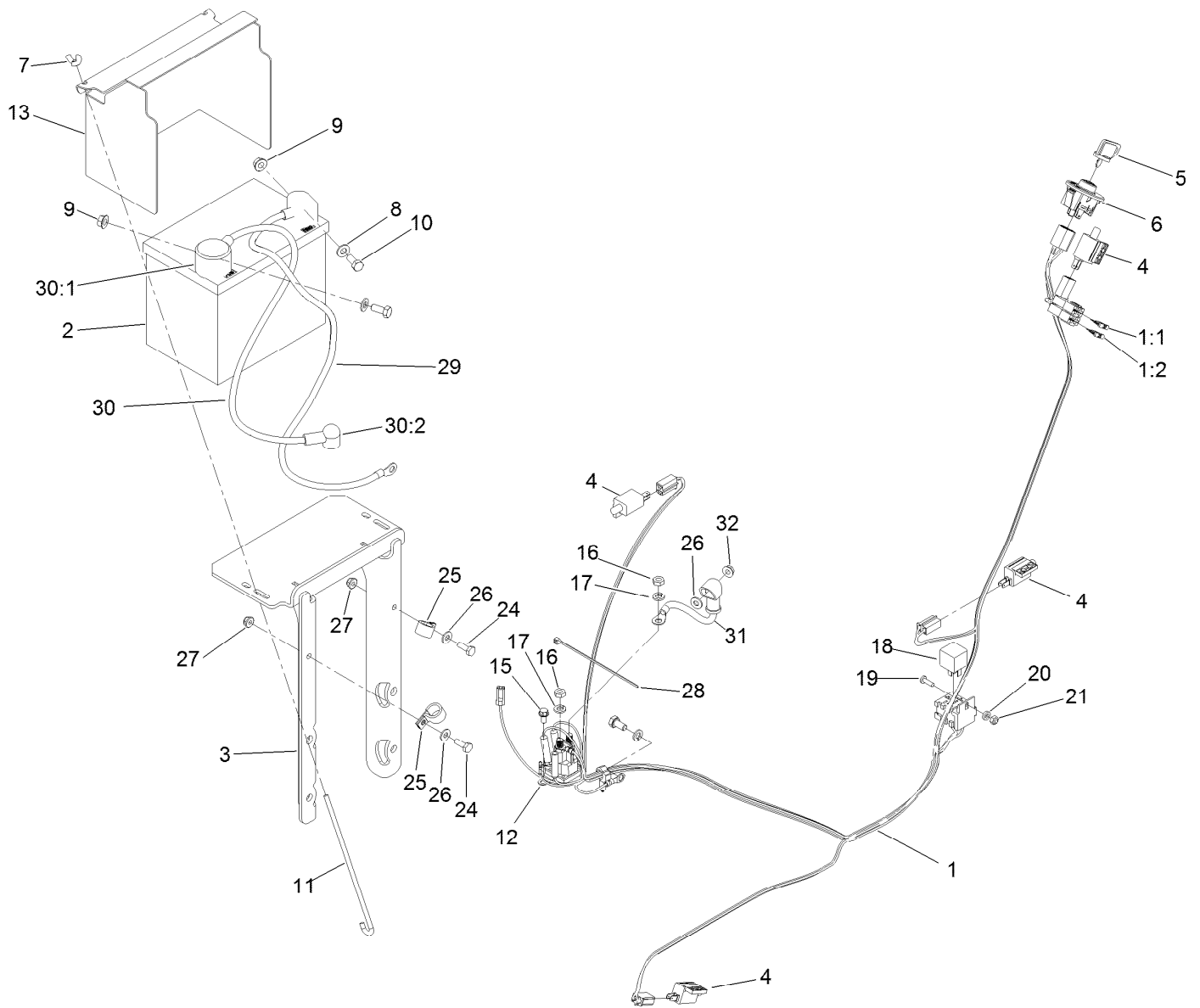

Electrical Assembly

Ref.	Part Number	Qty.	Description	Ref.	Part Number	Qty.	Description
1	119-6667	1	Harness-Wire	17	3253-4	2	Washer-Lock
1:1	109103	1	Fuse-Blade, 30 Amp	18	98-7249	1	Relay
1:2	109102	1	Fuse-Blade, 25 Amp	19	3290-500	1	Screw-PPH
2	104-8162	1	Battery	20	99-3058	1	Washer
3	119-6666-03	1	Tray-Battery	21	3296-2	1	Nut-Lock, NI
4	1-513051	4	Switch-Open, Normally	24	321-4	2	Screw-HH
5	63-8360	1	Key-Ignition (W/Shield)	25	2412-87	2	Clamp-Cable
6	117-2221	1	Switch-Ignition	26	3256-22	2	Washer-Flat
7	1-543792	2	Wingnut	27	104-7201	2	Nut-HF
8	3256-23	2	Washer-Flat	28	1-303287	1	Tie-Cable
9	109-5715	2	Nut-HHF, Smooth	29	117-6422	1	Cable-Battery, Black
10	322-3	2	Screw-HH	30	109-7653	1	Positive Battery Cable ASM
11	1-633651	2	Bolt-Holddown	30:1	109-2407	1	Insulator-Battery
12	117-1197	1	Solenoid	30:2	1-543393	1	Insulator-Solenoid
13	117-0543-01	1	Cover-Battery	31	106-8268	1	Cable-Battery, Red
15	32144-4	2	Screw-HWH	32	32128-33	1	Nut-HF
16	3220-2	2	Nut-Jam				

Attachments and Accessories

For 30069 Commercial Walk-Behind Traction Unit 18HP Pistol-Grip Hydro Drive

Product Name	Model/Part
32in (82cm) Mid-Size Rear-Discharge Deck	02710
36in (92cm) Mid-Size Rear-Discharge Deck	02711
48in (122cm) Mid-Size Rear-Discharge Deck	02712
36in (92cm) Mid-Size Flail Attachment	02720
Cleated Tire Kit	02930
Dual Wheel Kit	02931
Narrow Wheel Kit	02932
Weight Kit	110-2085
Sulky	30109

Notes:

Notes:



Count on it.