



**Count on it.**

**Parts Catalog**

**Commercial Walk-Behind Mower  
Floating Deck, T-Bar, Gear Drive with 48in  
TURBO FORCE® Cutting Unit**

**Model No. 39078—Serial No. 313000001 and Up**



# Ordering Replacement Parts

To order replacement parts, please supply the part number, the quantity, and the description of each part desired.

## Understanding Reference Numbers

Each identified part in an illustration has a reference number. The reference number for a part also appears in the parts list, along with other information about the part.

This catalog uses two special reference number formats, one to indicate parts in a service assembly and another to indicate the quantity of a given part in an illustration.

## Service Assembly Reference Numbers

Parts in service assemblies have reference numbers in the form a:b. The a represents the reference number of the entire service assembly and the b represents a sequential number unique to each part within the service assembly.

For example, a wheel assembly might be identified by reference number 6, the tire by 6:1, the valve by 6:2, and the wheel by 6:3. When you order the assembly identified by reference number 6, you receive all parts identified by reference numbers 6:1, 6:2, and 6:3. However, you may also order any part individually. Reference numbers of this type appear in illustration and in parts lists.

## Reference Numbers Indicating Quantity

In an illustration, if a reference number indicates more than one part, the reference number has the form nX y. The n represents the quantity of the part, the X is the multiplication symbol, and the y represents the reference number.

For example, in an illustration, the reference number 2X 37 means that two of the parts identified by reference number 37 are indicated.

# List of Abbreviations

<b>AR:</b> as required	<b>HLH:</b> hex lag head	<b>PTO:</b> power-take-off
<b>ASM:</b> assembly	<b>HOC:</b> height-of-cut	<b>RH:</b> right hand
<b>BBC:</b> blade brake control	<b>HSBH:</b> hex socket button head	<b>ROPS:</b> roll-over protection system
<b>BHTF:</b> button head thread forming	<b>HSFH:</b> hex socket flat head	<b>RRB:</b> rear roller brush
<b>CARR:</b> carriage	<b>HSH:</b> hex socket head	<b>SFH:</b> slotted fillister head
<b>CCW:</b> counter clockwise	<b>HWH:</b> hex washer head	<b>SHH:</b> slotted hex head
<b>CW:</b> clockwise	<b>HWHTF:</b> hex washer head thread forming	<b>SHWH:</b> slotted hex washer head
<b>DEG:</b> degrees	<b>HYD:</b> hydraulic	<b>SPH:</b> slotted pan head
<b>DPA:</b> Dual Point Adjustment	<b>LH:</b> left hand	<b>SQH:</b> square head
<b>ECM:</b> electronic control module	<b>LP:</b> Liquefied Petroleum Gas	<b>SRH:</b> slotted round head
<b>EXT:</b> external	<b>LPG:</b> Liquefied Petroleum Gas	<b>STD:</b> standard
<b>FH:</b> flat head	<b>NI:</b> nylon insert	<b>TAP:</b> self tapping
<b>GA:</b> gauge	<b>NPTF:</b> national pipe thread fine	<b>TTH:</b> torx truss head
<b>HD:</b> heavy-duty	<b>PFH:</b> phillips flat head	
<b>HF:</b> hex flange	<b>PPH:</b> phillips pan head	
<b>HH:</b> hex head	<b>PPHTF:</b> phillips pan head thread forming	
<b>HHF:</b> hex head flange	<b>PRH:</b> phillips round head	
<b>HHFTF:</b> hex head flange thread forming	<b>PTH:</b> phillips truss head	
<b>HJ:</b> hex jam		

# Contents

Engine and Clutch Assembly .....	4
Power-Take-Off Idler and Weight Assembly .....	5
Fuel System Assembly .....	6
Lower Control Assembly .....	7
Transmission Drive Assembly .....	8
Wheel Drive and Brake Assembly .....	9
Handle Assembly .....	10
Control Panel Assembly .....	11
Carrier Frame Assembly .....	12
Deck Drive and Baffle Assembly .....	13
Deck Decal Assembly No. 112-7082 .....	14
Spindle Assembly No. 110-0728 .....	15
Spindle Assembly No. 110-0729 .....	16
Deck Assembly .....	17
Deflector Assembly No. 110-0758 .....	18
Attachments and Accessories .....	19



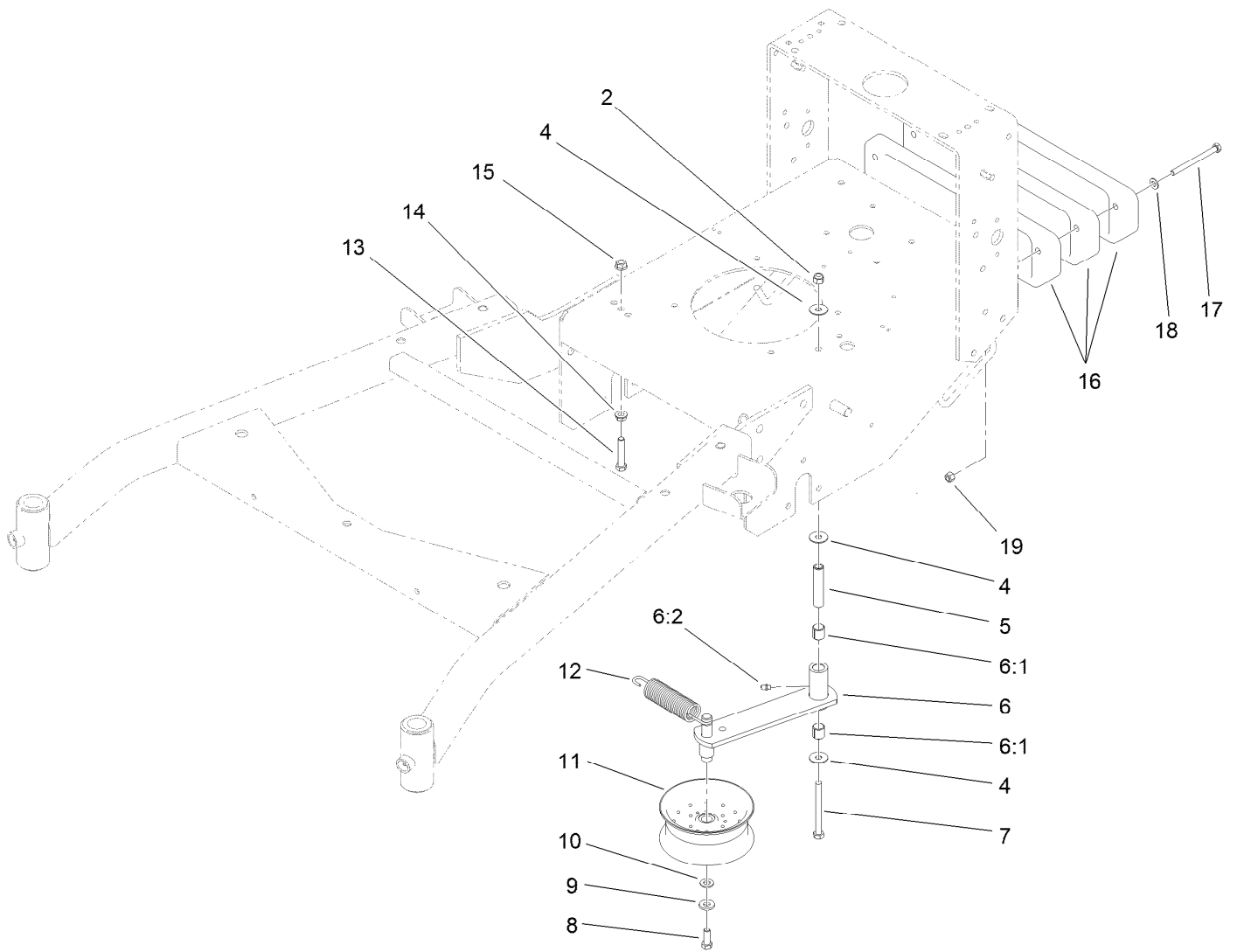

## Power-Take-Off Idler and Weight Assembly

<i>Ref.</i>	<i>Part Number</i>	<i>Qty.</i>	<i>Description</i>	<i>Ref.</i>	<i>Part Number</i>	<i>Qty.</i>	<i>Description</i>
2	3296-39	1	Nut-Lock, NI	11	116-4666	1	Idler-Pulley, Flat
4	52-2860	3	Washer	12	105-8443	1	Spring-Extension
5	104-6377	1	Tube-Idler	13	323-10	1	Screw-HH
6	108-2734	1	Idler Arm ASM	14	3290-357	1	Nut-HHF, Whiz
6:1	1-513034	2	Sleeve-Bearing	15	32128-21	1	Nut-HF
6:2	302-5	1	Fitting-Grease	16	112-7059-01	3	Weight-Cast
7	323-42	1	Screw-HH	17	322-38	2	Screw-HH
8	323-6	1	Screw-HH	18	3256-23	2	Washer-Flat
9	98-5975	1	Washer-Belleville	19	3296-29	2	Nut-Lock, NI
10	3256-24	1	Washer-Flat				

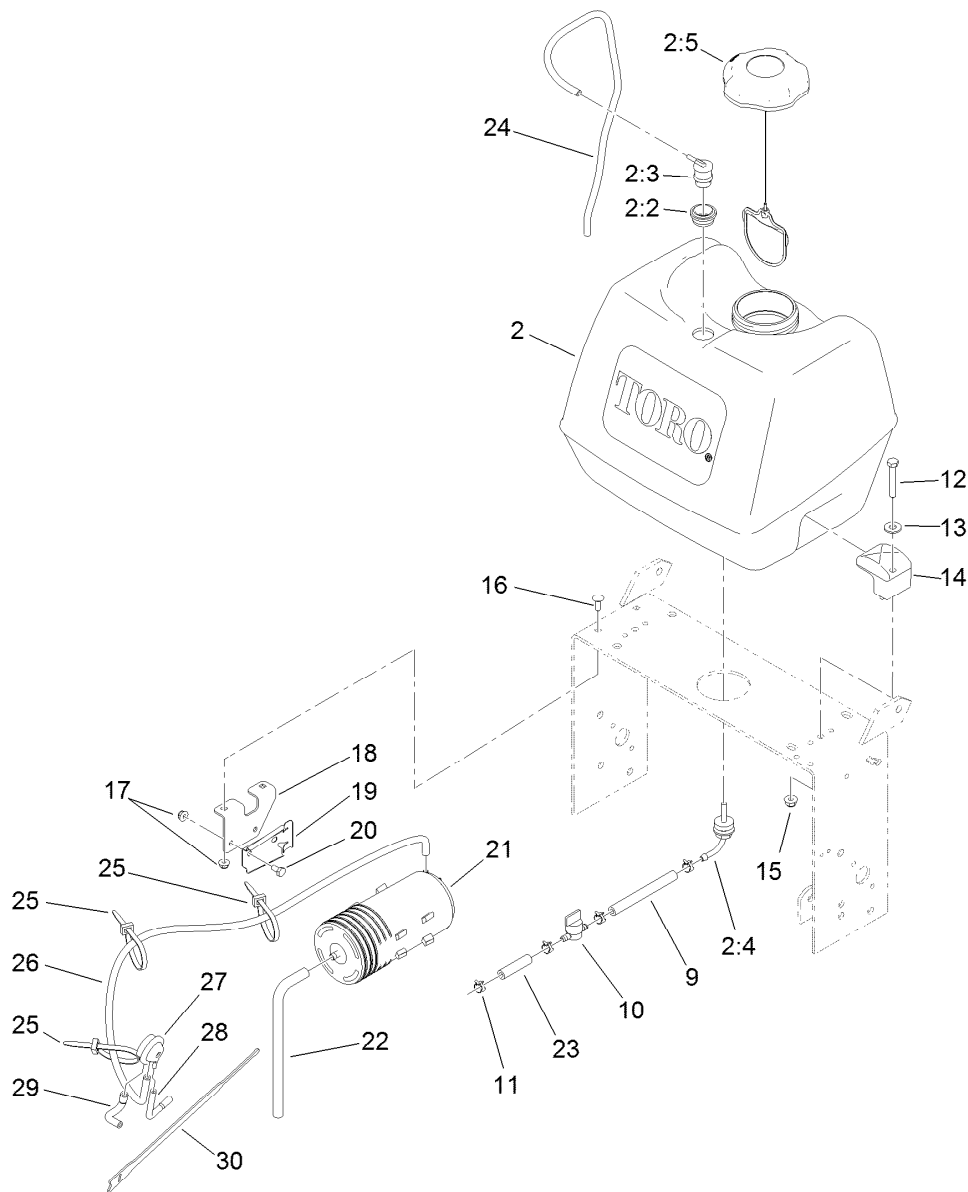

## Fuel System Assembly

Ref.	Part Number	Qty.	Description	Ref.	Part Number	Qty.	Description
2	119-7899	1	Fuel Tank ASM	18	115-4486-01	1	Bracket-Canister, Carbon
2:2	114-0284	1	Grommet	19	114-0292	1	Bracket-Canister, Carbon
2:3	114-0285	1	Valve-Rollover	20	321-2	2	Screw-HH
2:4	103-2605	1	Fitting-Fuel, Bulkhead	21	117-1221	1	Canister-Carbon, 800Cc
2:5	120-5461	1	Cap-Fuel, Ratcheting	22	115-0962	1	Hose-Vent, Canister
9	109-0650	1	Hose-Fuel	23	99-9415	1	Hose-Fuel
10	1-603770	1	Valve-Fuel	24	114-0286	1	Hose-Vent
11	2412-98	4	Clamp-Hose	25	3290-378	3	Tie-Cable
12	322-10	2	Screw-HH	26	116-2231	1	Hose-Vent, Formed
13	3256-3	2	Washer-Flat	27	116-2232	1	Valve-Control, Vacuum
14	107-4543	2	Clamp	28	119-8501	1	Hose-Vent, Formed
15	104-8300	2	Nut-Flange, NI	29	119-8502	1	Hose-Vent, Formed
16	3229-1	2	Bolt-CARR	30	116-2469	1	Strap-Velcro, Cable Tie
17	104-7201	4	Nut-HF				

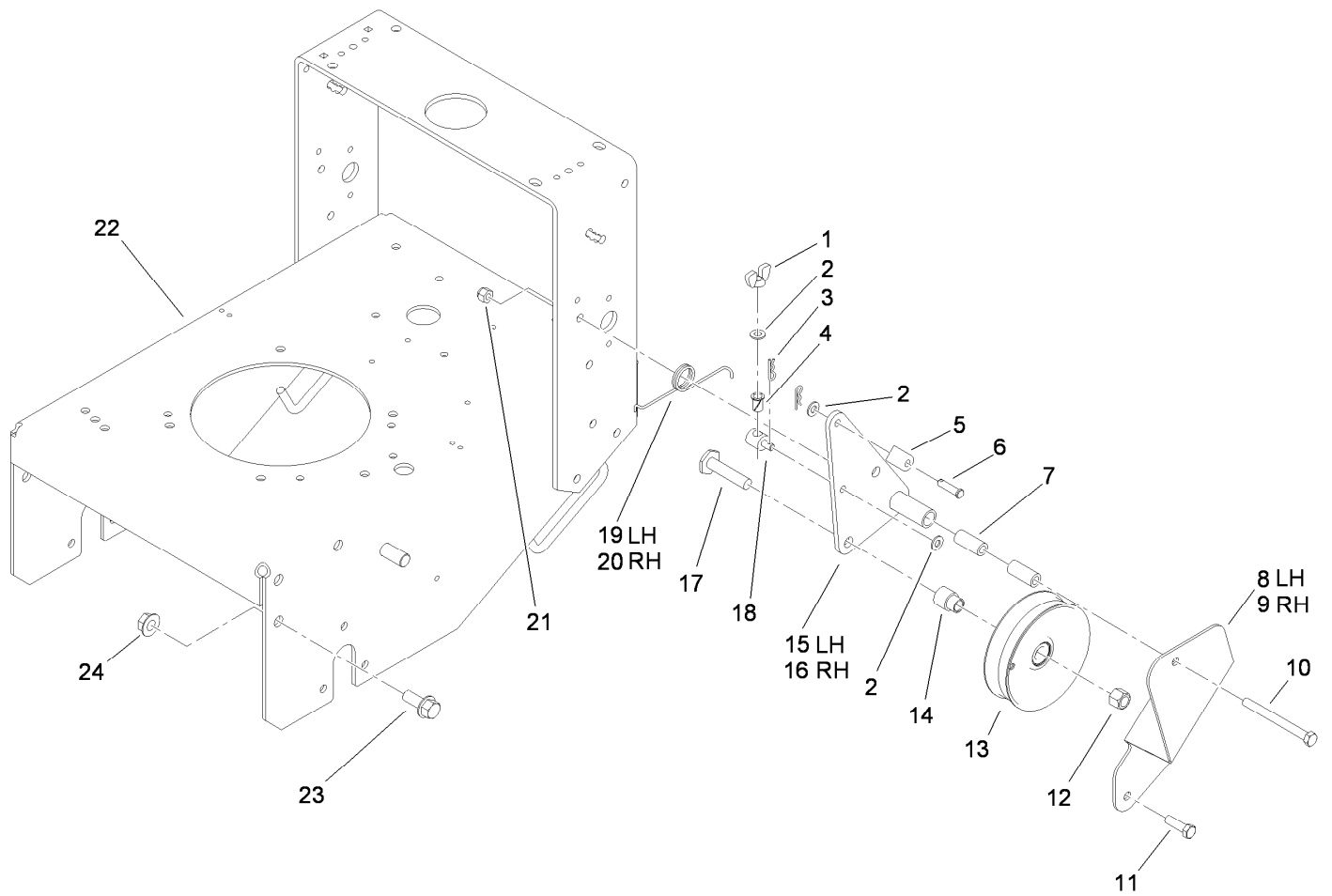

## Lower Control Assembly

<i>Ref.</i>	<i>Part Number</i>	<i>Qty.</i>	<i>Description</i>
1	32103-25	2	Nut-Wing
2	3256-23	6	Washer-Flat
3	3290-307	4	Pin-Hair
4	52-2890	2	Bushing-Nylon
5	74-0521	2	Fitting-Rod
6	283-6	2	Pin-Clevis
7	74-0040	4	Spacer-Pivot, Idler
8	108-2725-01	1	Support-Idler, LH
9	108-2724-01	1	Support-Idler, RH
10	323-16	2	Screw-HH
11	323-7	4	Screw-HH
12	3296-23	2	Nut-Lock, NI

<i>Ref.</i>	<i>Part Number</i>	<i>Qty.</i>	<i>Description</i>
13	95-2800	2	Pulley-Idler
14	95-2801	2	Spacer-Pulley
15	108-2740-01	1	Arm-Idler, LH
16	108-2741-01	1	Arm-Idler, RH
17	51-4450	2	Screw-Leveler
18	68-9690	2	Fitting-Rod
19	51-4380	1	Spring-Torsion, LH
20	51-4370	1	Spring-Torsion, RH
21	3296-39	6	Nut-Lock, NI
22	117-5236-01	1	Frame-Gear
23	3234-32	6	Screw-HHF
24	32128-23	6	Nut-HF

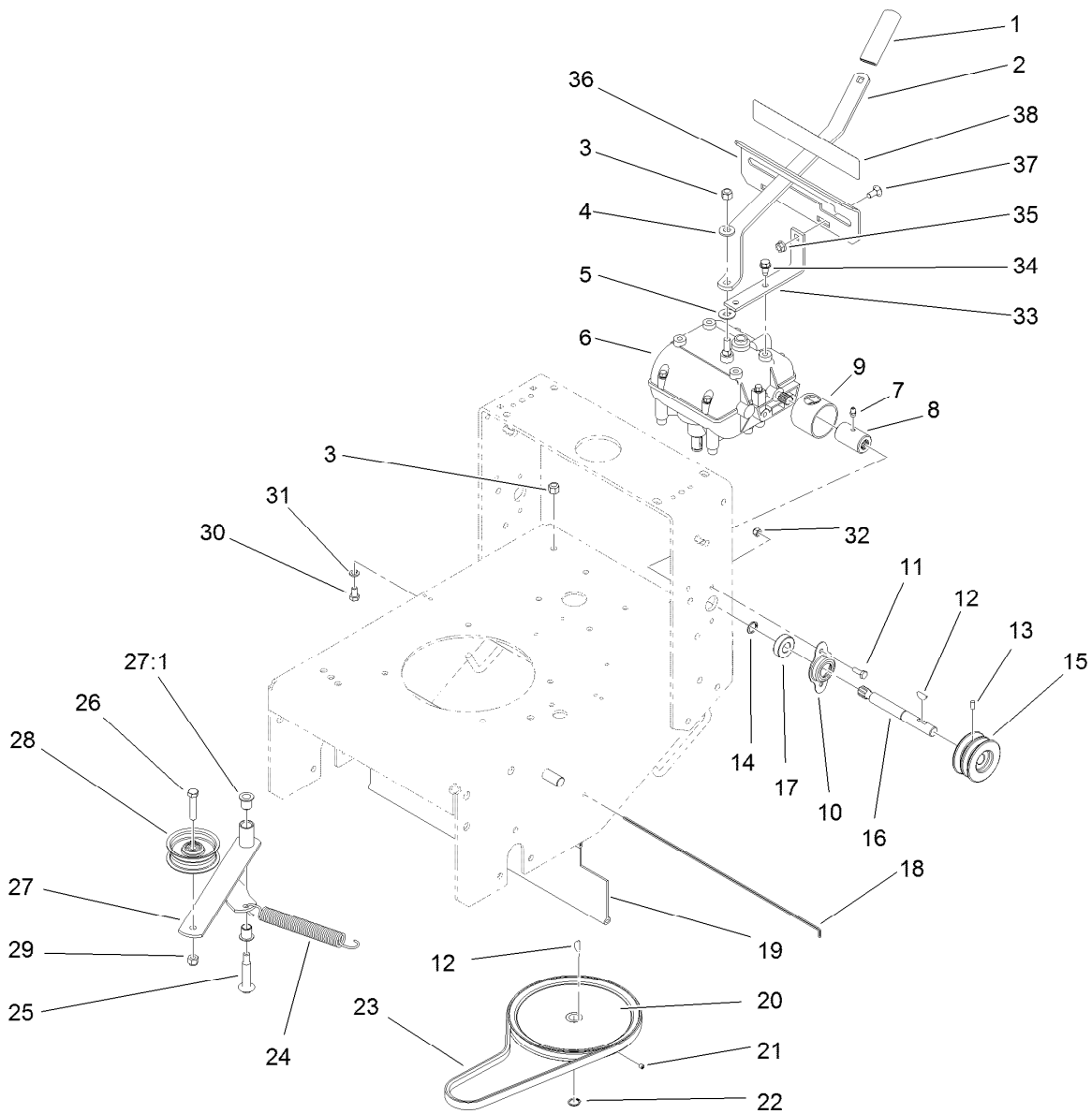

## Transmission Drive Assembly

Ref.	Part Number	Qty.	Description	Ref.	Part Number	Qty.	Description
1	47-1970	1	Grip	21	3245-41	1	Screw-HSH
2	98-3274-03	1	Lever-Shift	22	32120-64	1	Ring-Snap, External
3	3296-6	2	Nut-Lock	23	105-5668	1	V-Belt
4	98-5975	1	Washer-Belleville	24	80-6610	1	Spring-Extension
5	1-323379	1	Washer	25	27-6230	1	Bolt-Wheel
6	1-323500	1	Transmission	26	323-9	1	Screw-HH
7	302-5	2	Fitting-Grease	27	16-7509	1	Lever-Idler
8	1-323680	2	Coupler	27:1	256-155	2	Bushing-Flange
9	51-4220	2	Guard-Coupler	28	62-4540	1	Pulley
10	1-323254	2	Flange-Output	29	3296-39	1	Nut-Lock, NI
11	321-4	4	Screw-HH	30	322-2	4	Screw-HH
12	3257-5	3	Key-Woodruff	31	3253-4	4	Washer-Lock
13	121-5989	2	Screw-Set, HSH	32	3296-42	4	Nut-Lock, NI
14	32151-62	2	Ring-Retaining	33	1-323389-03	2	Bracket-Plate, Shift
15	105-2698	2	Pulley-Transmission	34	32144-11	4	Screw-HWHTF
16	104-1102	2	Shaft-Output	35	104-8300	2	Nut-Flange, NI
17	1-323252	2	Bearing-Shaft	36	1-323387-03	1	Plate-Shift
18	95-1529	1	Rod-Shield	37	3230-1	2	Bolt-CARR
19	95-1526	1	Shield-Trailing	38	98-3256	1	Decal-Speed, Ground
20	105-5646	1	Pulley-Driven				



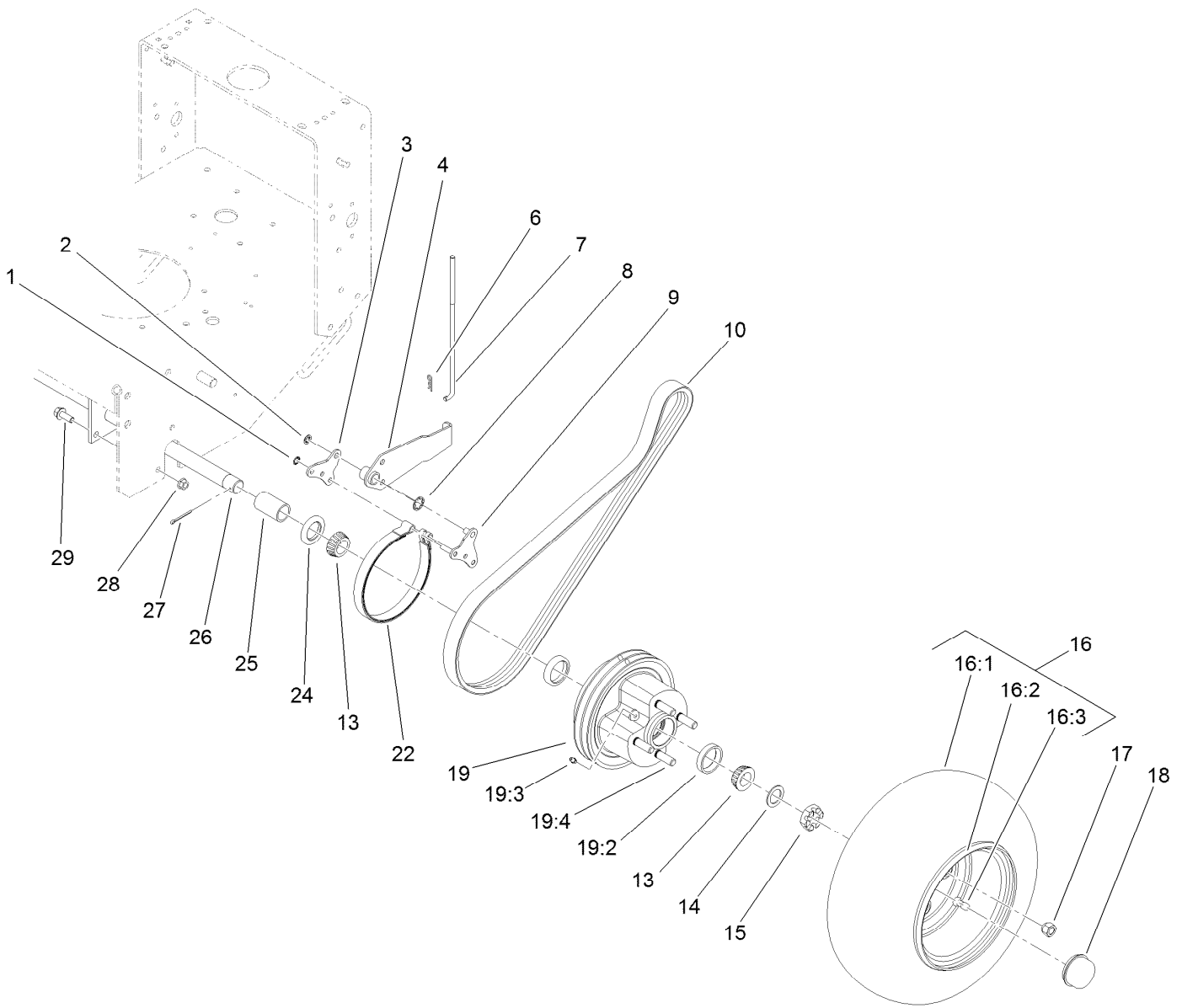

## Wheel Drive and Brake Assembly

Ref.	Part Number	Qty.	Description	Ref.	Part Number	Qty.	Description
1	32151-72	4	Ring-Retaining	16:3	232-27	1	Stem-Valve
2	32151-56	2	Ring-Retaining, External	17	242-50	8	Nut-Lug
3	106-8792	2	Plate-Link, Brake	18	241-119	2	Cap-Dust
4	110-5010-01	2	Arm-Brake	19	107-4090	2	Wheel Hub ASM
6	3290-307	2	Pin-Hair	19:2	1-543508	2	Cup-Bearing
7	108-2730	2	Rod-Brake	19:3	302-5	1	Fitting-Grease
8	32151-40	2	Ring-Retaining	19:4	10-6830	4	Stud-Type, Drive
9	106-8773	2	Brake Link ASM	22	1-323262	2	Band-Brake
10	108-2723	2	Belt-V, Banded	24	1-543511	2	Seal-Grease
13	1-543509	4	Bearing-Roller, Tapered	25	110-5006	2	Spacer-Wheel
14	1-523157	2	Washer-Spacer	26	110-4983-01	1	Axle
15	1-809082	2	Nut-SHH	27	1-806800	2	Pin-Cotter
16	106-0892	2	Wheel And Tire ASM	28	32128-21	6	Nut-HF
16:1	104-6322	1	Tire	29	3234-11	6	Screw-HHF
16:2	106-0893	1	Wheel				

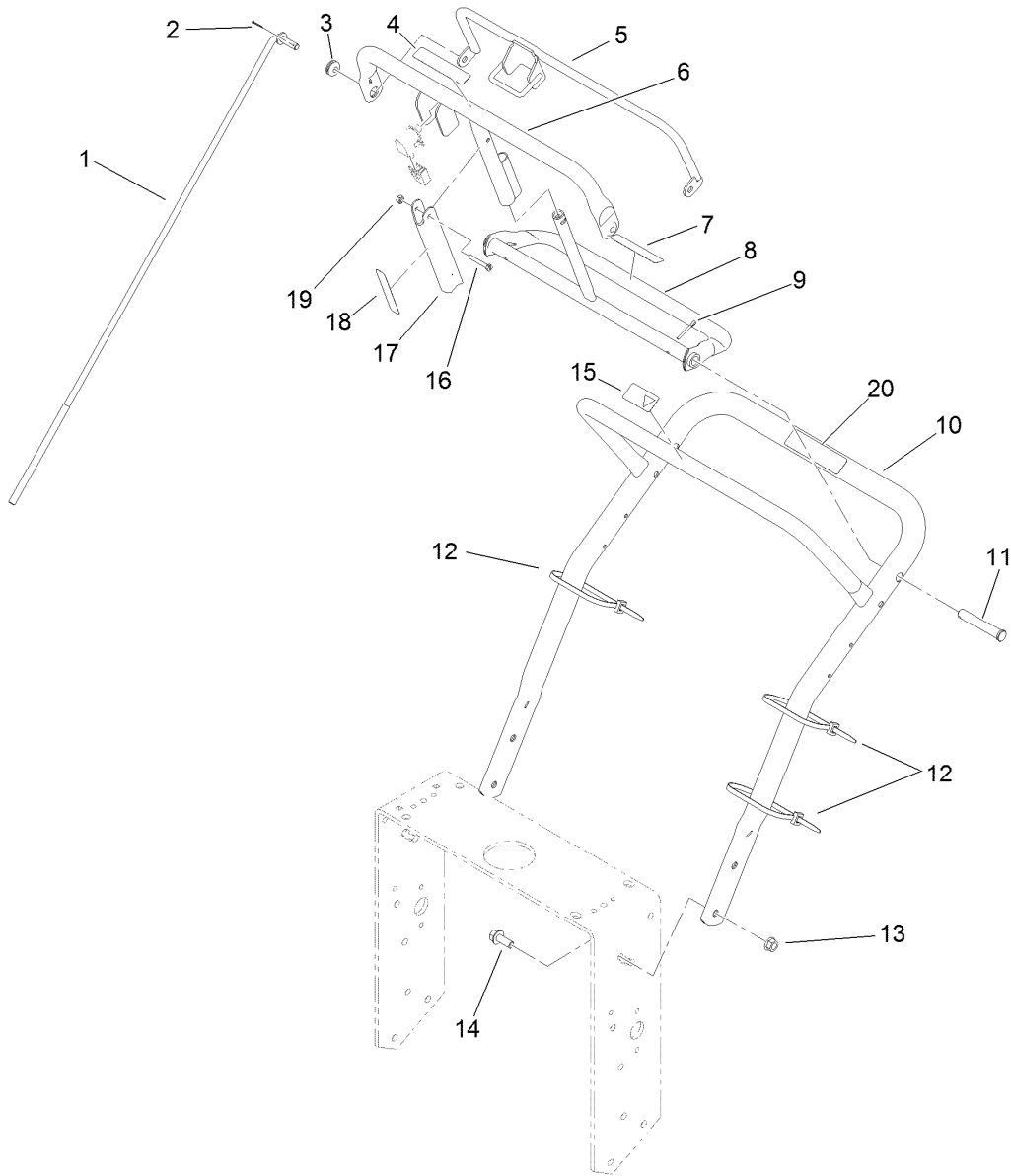

## Handle Assembly

<i>Ref.</i>	<i>Part Number</i>	<i>Qty.</i>	<i>Description</i>	<i>Ref.</i>	<i>Part Number</i>	<i>Qty.</i>	<i>Description</i>
1	105-4677	2	Rod-Control	11	283-55	2	Pin-Clevis
2	3272-4	2	Pin-Cotter	12	3290-378	3	Tie-Cable
3	237-141	2	Grommet-Rubber	13	32128-21	4	Nut-HF
4	82-2290	1	Decal	14	3234-11	4	Screw-HHF
5	82-7680-03	1	Bail	15	98-4387	1	Decal-Protection, Ear
6	82-7690-03	1	Bar-Control	16	32105-1	1	Screw-SHH
7	82-2280	1	Decal	17	51-4850-03	1	Lever-Brake, Parking
8	106-5477-03	1	Pivot-Control	18	52-2010	1	Decal-Lever, Parking
9	3272-11	2	Pin-Cotter	19	3296-2	1	Nut-Lock, NI
10	105-3158-03	1	Handle-Upper	20	117-2718	1	Decal-Arrester, Spark

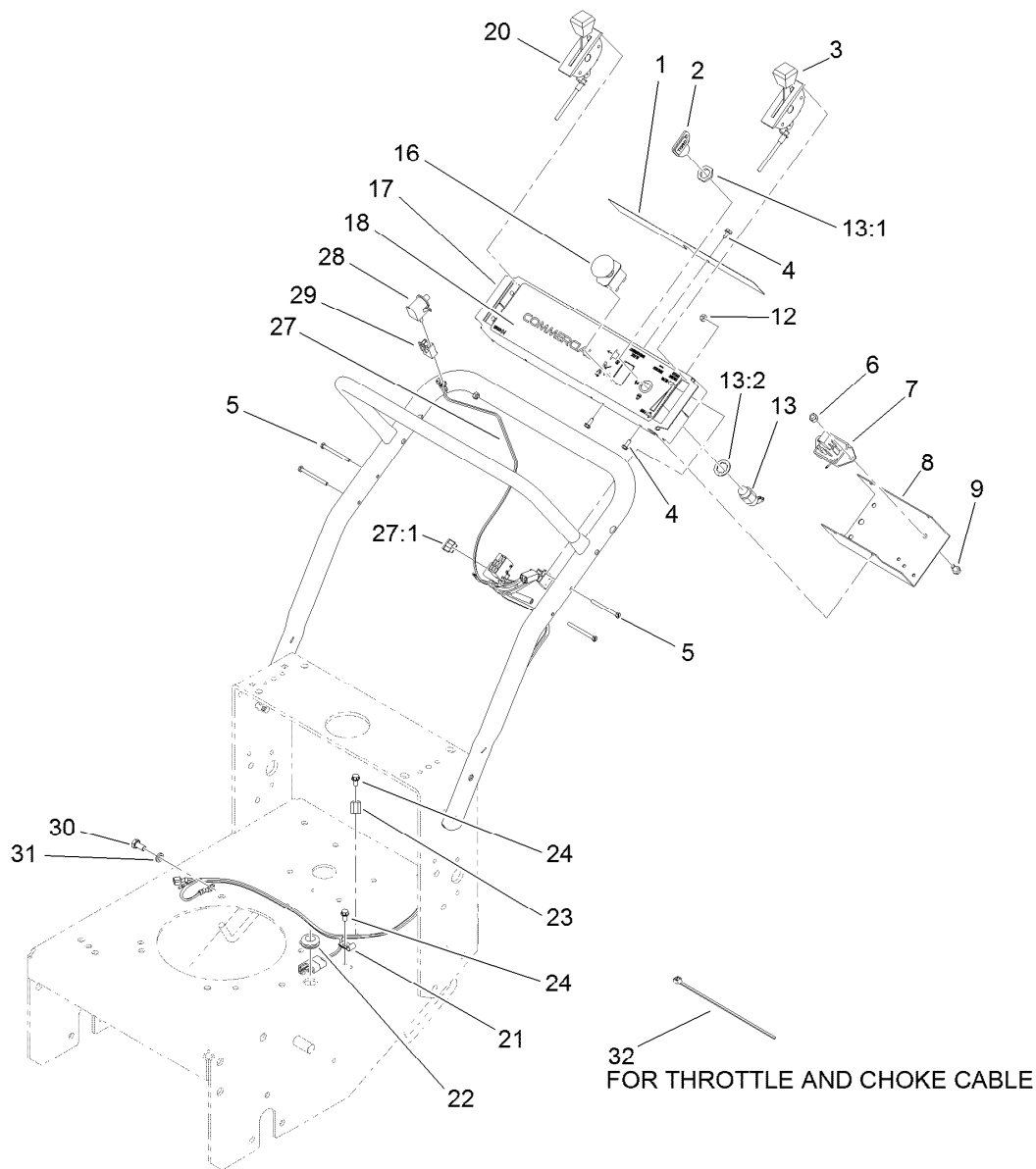

## Control Panel Assembly

<i>Ref.</i>	<i>Part Number</i>	<i>Qty.</i>	<i>Description</i>	<i>Ref.</i>	<i>Part Number</i>	<i>Qty.</i>	<i>Description</i>
1	105-0884	1	Decal-Danger	17	110-4982-03	1	Panel-Control
2	63-8360	1	Key-Ignition (W/Shield)	18	110-4971	1	Decal-Panel, Control
3	119-6539	1	Cable-Throttle	20	110-4995	1	Cable-Choke
4	32104-76	4	Screw-Thd Cutting, HWH	21	2412-72	1	Clip-Closed, Insulated
5	32105-14	4	Screw-SHH	22	112-7069	1	Grommet
6	3296-42	1	Nut-Lock, NI	23	2412-134	1	Clamp-R
7	104-8141	1	Module-Delay	24	32144-4	2	Screw-HWH
8	93-1187-03	1	Panel-Bottom	27	119-6508	1	Harness-Wire
9	321-2	1	Screw-HH	27:1	114241	1	Fuse-Blade, 7.5 Amp
12	3296-2	4	Nut-Lock, NI	28	82-2190	1	Switch-Bail
13	29-5560	1	Switch-On / Off	29	218-595	1	Connector-Body
13:1	218-461	1	Nut-HH	30	33114-016	1	Screw-HH
13:2	3254-5	1	Washer-Tooth, Internal	31	3253-4	1	Washer-Lock
16	104-8140	1	Switch-PTO	32	1-303287	1	Tie-Cable

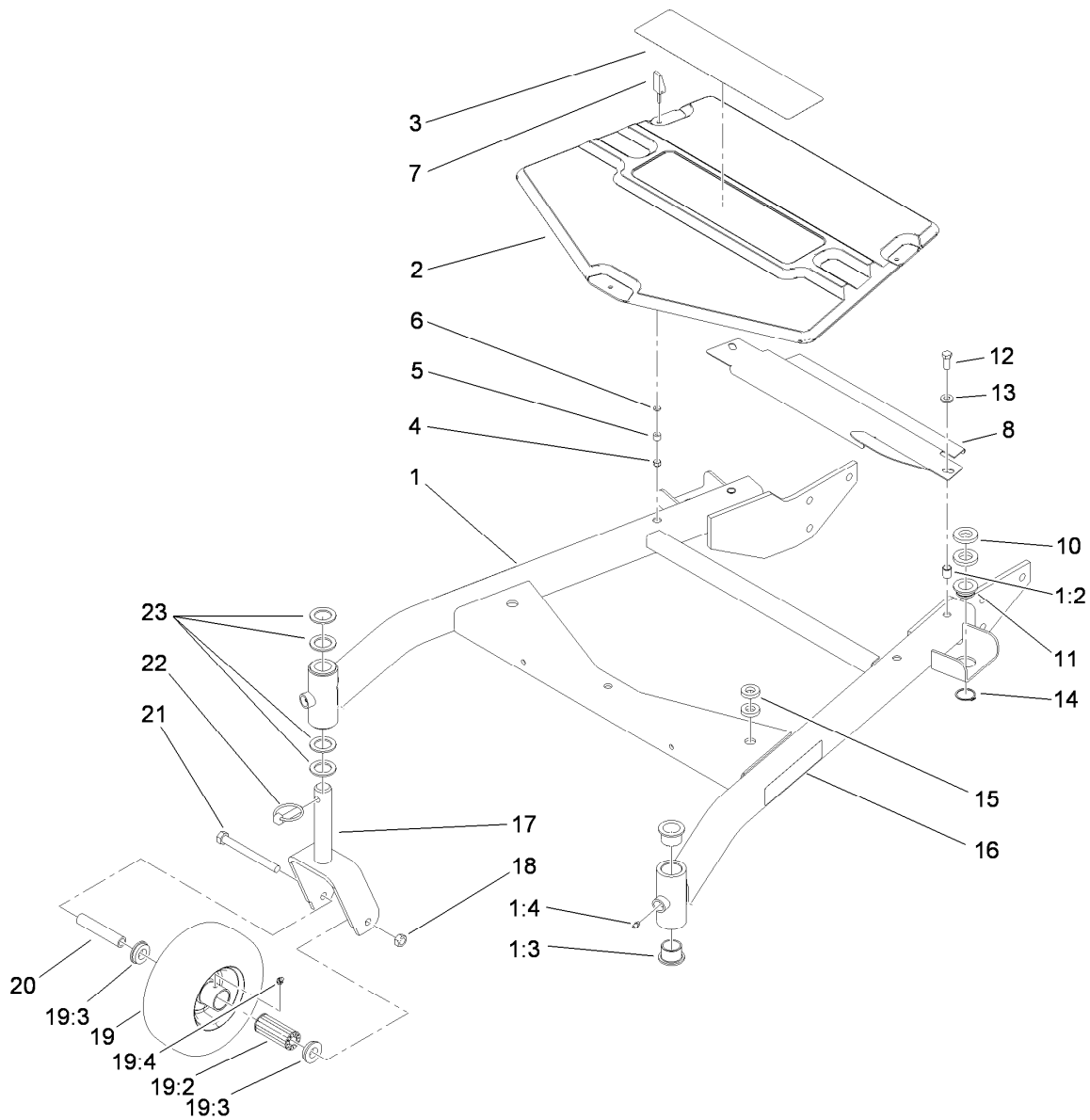

## Carrier Frame Assembly

<i>Ref.</i>	<i>Part Number</i>	<i>Qty.</i>	<i>Description</i>	<i>Ref.</i>	<i>Part Number</i>	<i>Qty.</i>	<i>Description</i>
1	108-2665	1	Carrier Frame ASM	13	3256-24	2	Washer-Flat
1:2	32148-9	2	Insert-Nut	14	32120-33	2	Ring-Retaining
1:3	94-1291	4	Bushing	15	1-323539	4	Spacer
1:4	302-5	2	Fitting-Grease	16	106-0635	2	Decal-HOC
2	108-6625	1	Cover-Frame, Carrier	17	105-3159-01	2	Fork-Castor
3	112-9712	1	Decal	18	32153-5	2	Nut-Hex
4	1-804254	3	Nut-Lock, HH	19	110-5024	2	Wheel And Tire ASM
5	106-6778	3	Bushing-Latch, Swell	19:2	112-7066	1	Bearing-Roller
6	99-3058	3	Washer	19:3	1-513810	2	Bushing
7	106-6777	3	Handle-Latch, Swell	19:4	302-61	1	Fitting-Grease
8	119-6534-01	1	Shield-Belt	20	100-6453	2	Bushing-Spanner
10	104-1105	4	Spacer-Support, Deck	21	325-19	2	Screw-HH
11	1-513336	2	Bushing-Deck	22	283-71	2	Pin-Lynch
12	323-6	2	Screw-HH	23	3-6781	8	Washer-Thrust

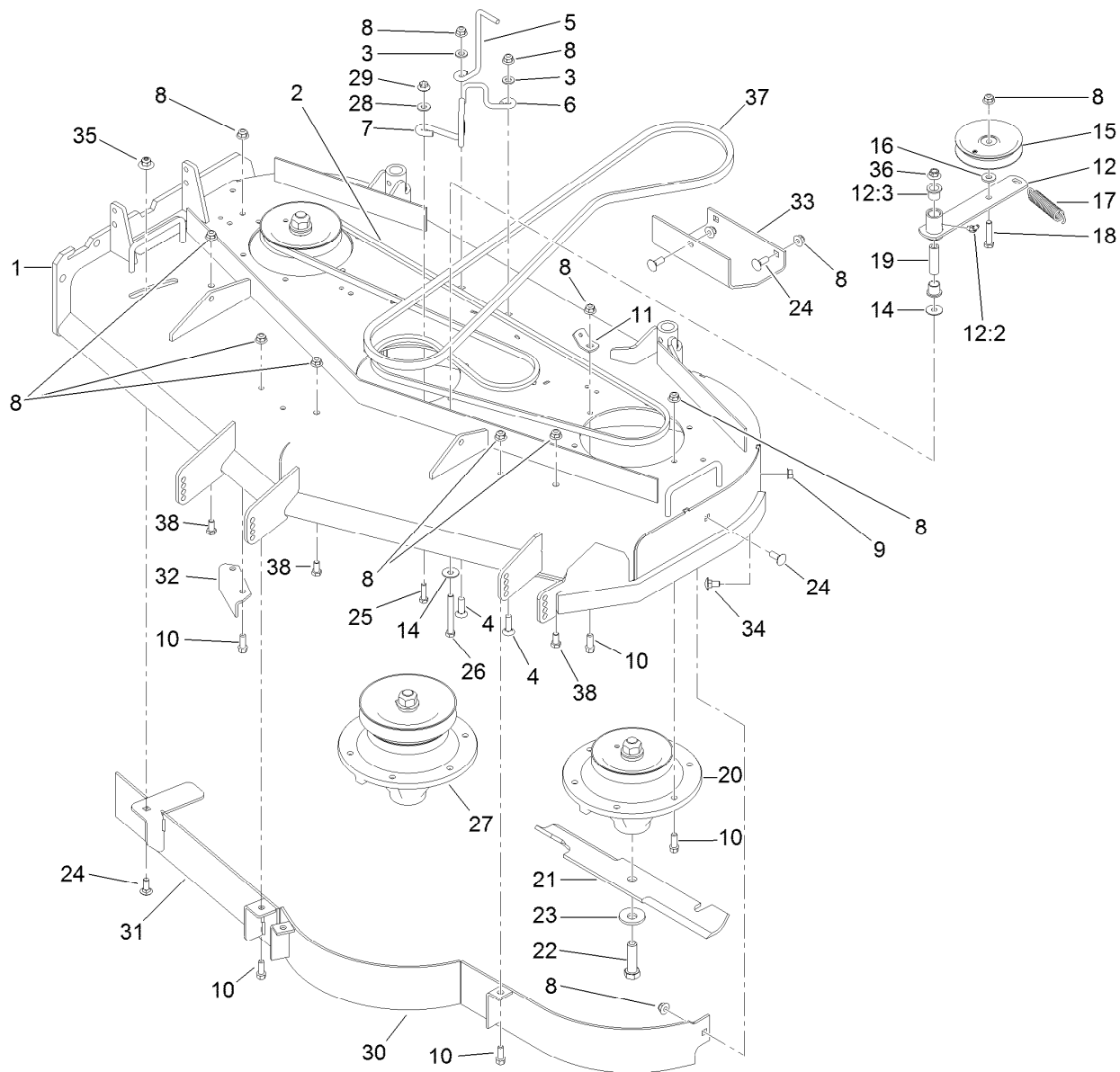

## Deck Drive and Baffle Assembly

Ref.	Part Number	Qty.	Description	Ref.	Part Number	Qty.	Description
1	112-7082	1	Deck ASM	20	110-0728	2	Spindle ASM
2	108-2716	1	Belt-V	21	107-3192-03	3	Blade-16.5 Inch (High Flow)
3	3256-24	2	Washer-Flat	22	51-4060	3	Screw-Blade
4	3231-28	2	Screw-CARR	23	103-0865	3	Washer-Blade Bolt, Heavy
5	98-5980	1	Guide-Belt	24	3231-2	5	Bolt-CARR
6	110-6975	1	Guide-Belt	25	322-6	1	Screw-HH
7	105-0850	1	Guide-Belt	26	323-14	1	Screw-HH
8	104-8301	35	Nut-Flange, NI	27	110-0729	1	Spindle ASM
9	32128-21	3	Nut-HF	28	3256-3	1	Washer-Flat
10	92-1624	22	Screw-HWH	29	32128-13	1	Nut-HHF
11	104-6374	1	Plate-Spring	30	110-0735-03	1	Baffle
12	108-2728	1	Idler Arm ASM	31	121-1792-03	1	Baffle
12:2	302-11	1	Fitting-Lube, 45 DEG	32	110-0744-01	1	Baffle-Discharge
12:3	256-90	2	Bushing-Flange	33	107-3166-01	1	Skid
14	52-2860	2	Washer	34	3231-1	3	Screw-CARR
15	93-1622	1	Pulley-Idler	35	109-6658	1	Nut-Flange, NI
16	9202414	1	Washer-Spacer	36	32128-19	1	Nut-HF
17	51-3650	1	Spring-Extension	37	108-2715	1	Belt-V
18	323-9	1	Screw-HH	38	323-4	3	Screw-HH
19	112-7091	1	Spacer				

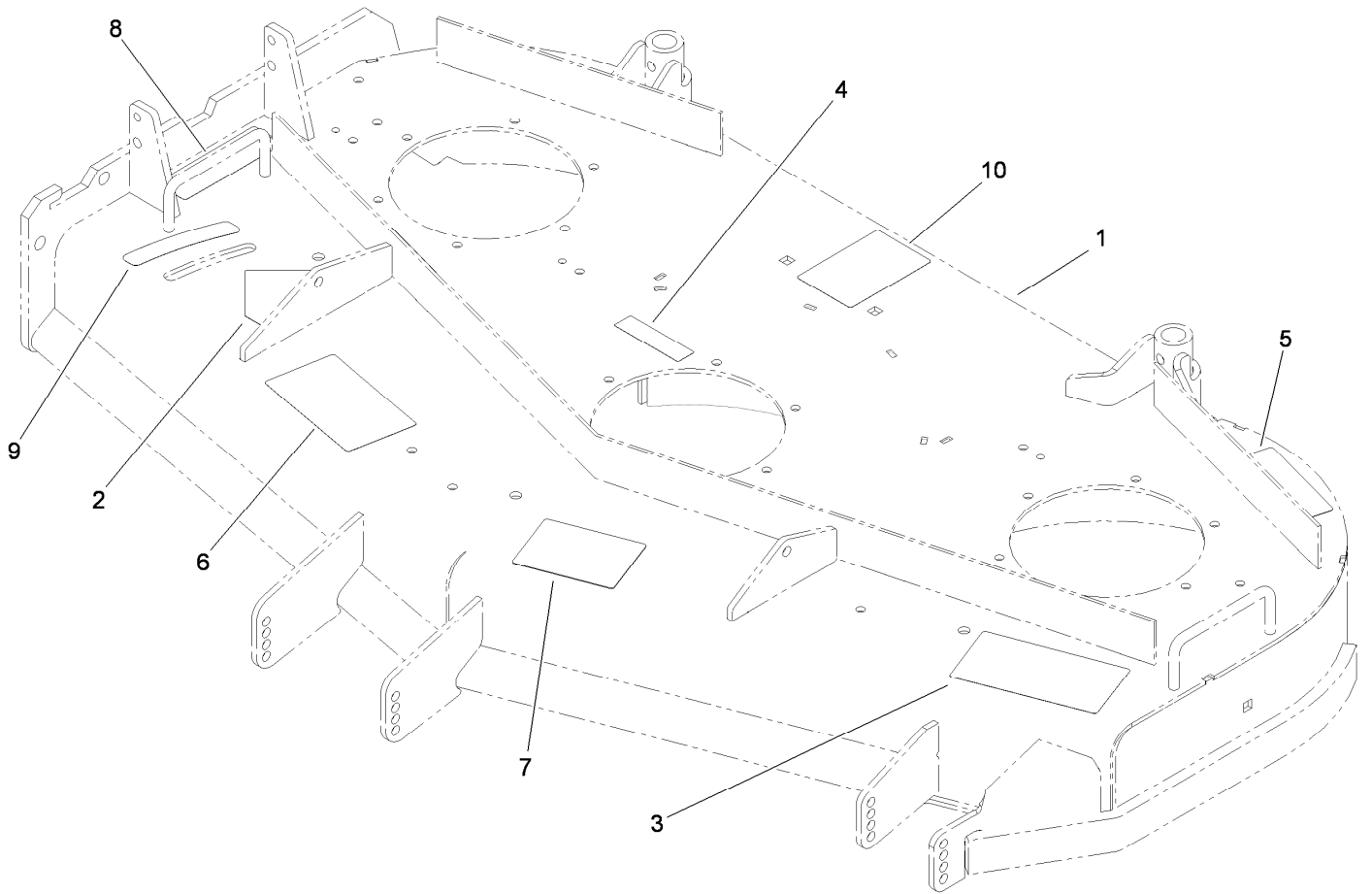

## Deck Decal Assembly No. 112-7082

<i>Ref.</i>	<i>Part Number</i>	<i>Qty.</i>	<i>Description</i>
1		1	48 Inch Deck ASM ●
2	1-403005	1	Decal-Danger
3	66-1340	1	Decal-Danger, Thrown Object
4	98-5954	3	Decal-Cover, Missing
5	68-8340	1	Decal-Torque
6	110-2068	1	Decal-Adjustment, Baffle
7	105-7798	1	Decal-Scalp, Anti
8	104-8569	1	Decal-Warning
9	110-2067	1	Decal-Setting, Baffle
10	104-8186	1	Decal-Routing, Belt

● Not serviced separately

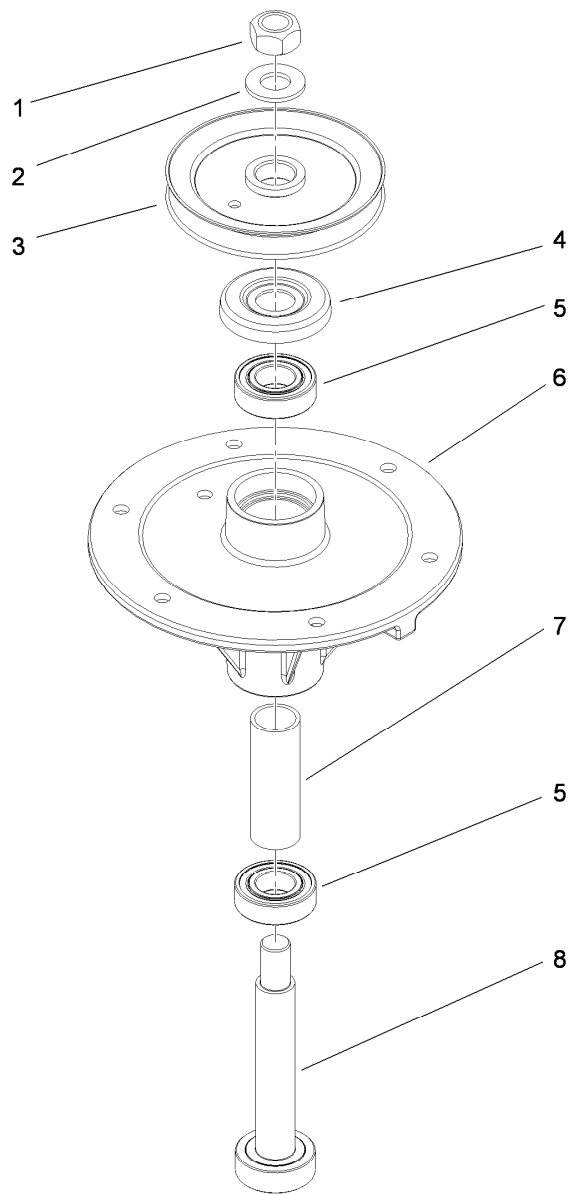

## Spindle Assembly No. 110-0728

<i>Ref.</i>	<i>Part Number</i>	<i>Qty.</i>	<i>Description</i>
1	3219-7	1	Nut-Hex
2	7-4150	1	Washer
3	104-1181	1	Pulley ASM
4	106-0873	1	Shield-Bearing
5	116-0720	2	Bearing-Ball
6	108-6696	1	Housing-Spindle
7	110-0727	1	Spacer-Bearing
8	110-0726	1	Shaft-Spindle

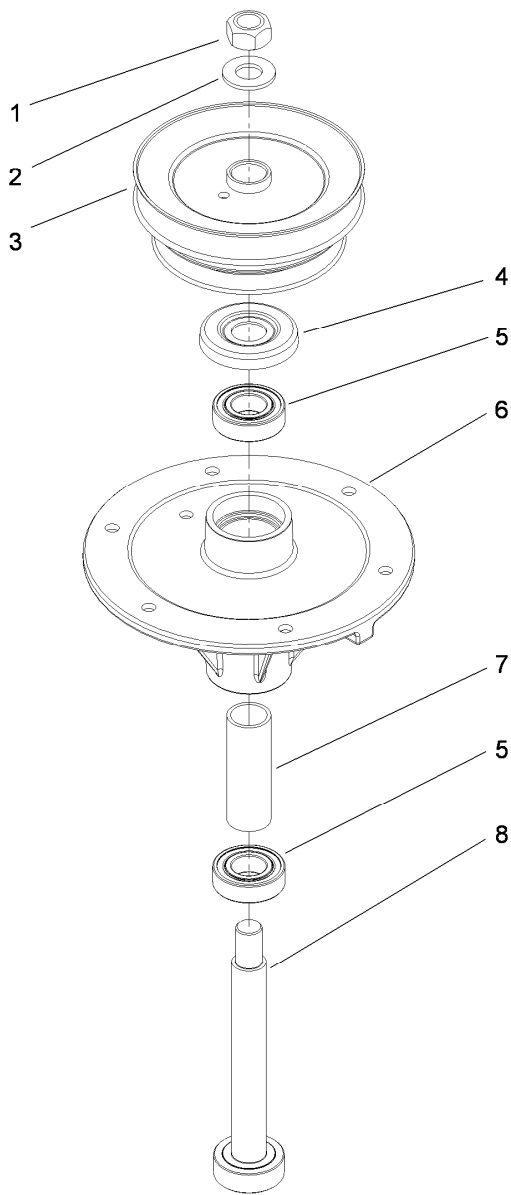

## Spindle Assembly No. 110-0729

<i>Ref.</i>	<i>Part Number</i>	<i>Qty.</i>	<i>Description</i>
1	3219-7	1	Nut-Hex
2	7-4150	1	Washer
3	108-2713	1	Pulley And Hub ASM
4	106-0873	1	Shield-Bearing
5	116-0720	2	Bearing-Ball
6	108-6696	1	Housing-Spindle
7	110-0727	1	Spacer-Bearing
8	110-0725	1	Shaft-Spindle



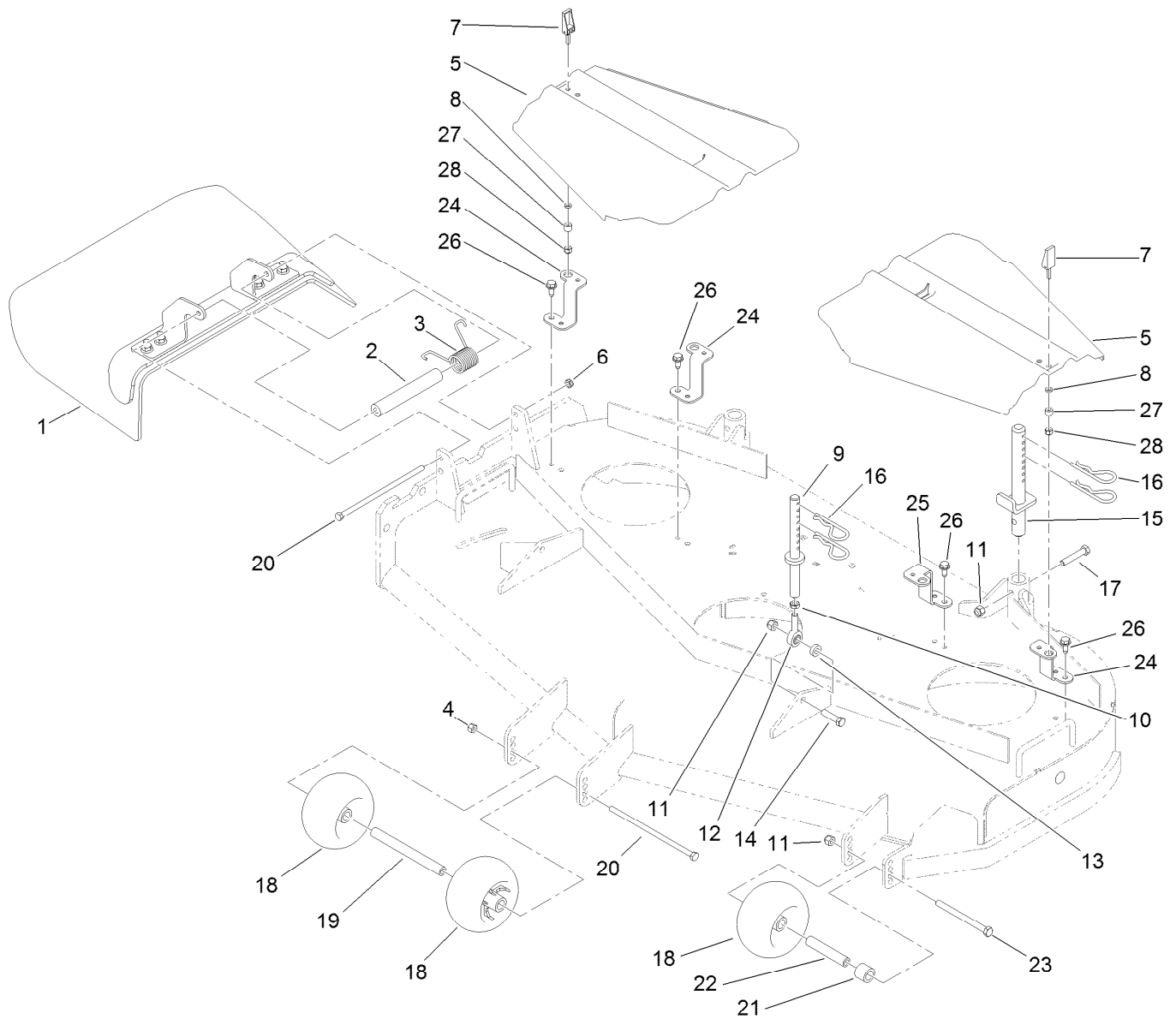

## Deck Assembly

Ref.	Part Number	Qty.	Description	Ref.	Part Number	Qty.	Description
1	110-0758	1	Deflector ASM	15	110-2086	2	Rear Pin ASM
2	105-4622	1	Spacer	16	3290-256	6	Pin-Hair
3	108-4052	1	Spring-Torsion	17	323-10	2	Screw-HH
4	3296-29	1	Nut-Lock, NI	18	1-603299	3	Roller-Scalp, Anti
5	107-8536	2	Cover-Belt	19	98-5967	1	Spacer-Wheel
6	3296-47	1	Nut-Lock, NI	20	322-50	2	Screw-HH
7	106-6777	2	Handle-Latch, Swell	21	98-7913	1	Tube-Spacer
8	99-3058	2	Washer	22	98-7912	1	Tube-Spanner
9	108-2674	2	Front Pin ASM	23	323-23	1	Screw-HH
10	3220-3	2	Nut-HJ	24	108-2698-01	3	Bracket-Cover
11	3296-39	5	Nut-Lock, NI	25	108-2699-01	1	Bracket-Cover
12	1-613204	2	Balljoint	26	32144-70	4	Screw-HWHTF
13	104-1156	2	Spacer	27	106-6778	2	Bushing-Latch, Swell
14	323-8	2	Screw-HH	28	1-804254	2	Nut-Lock, HH

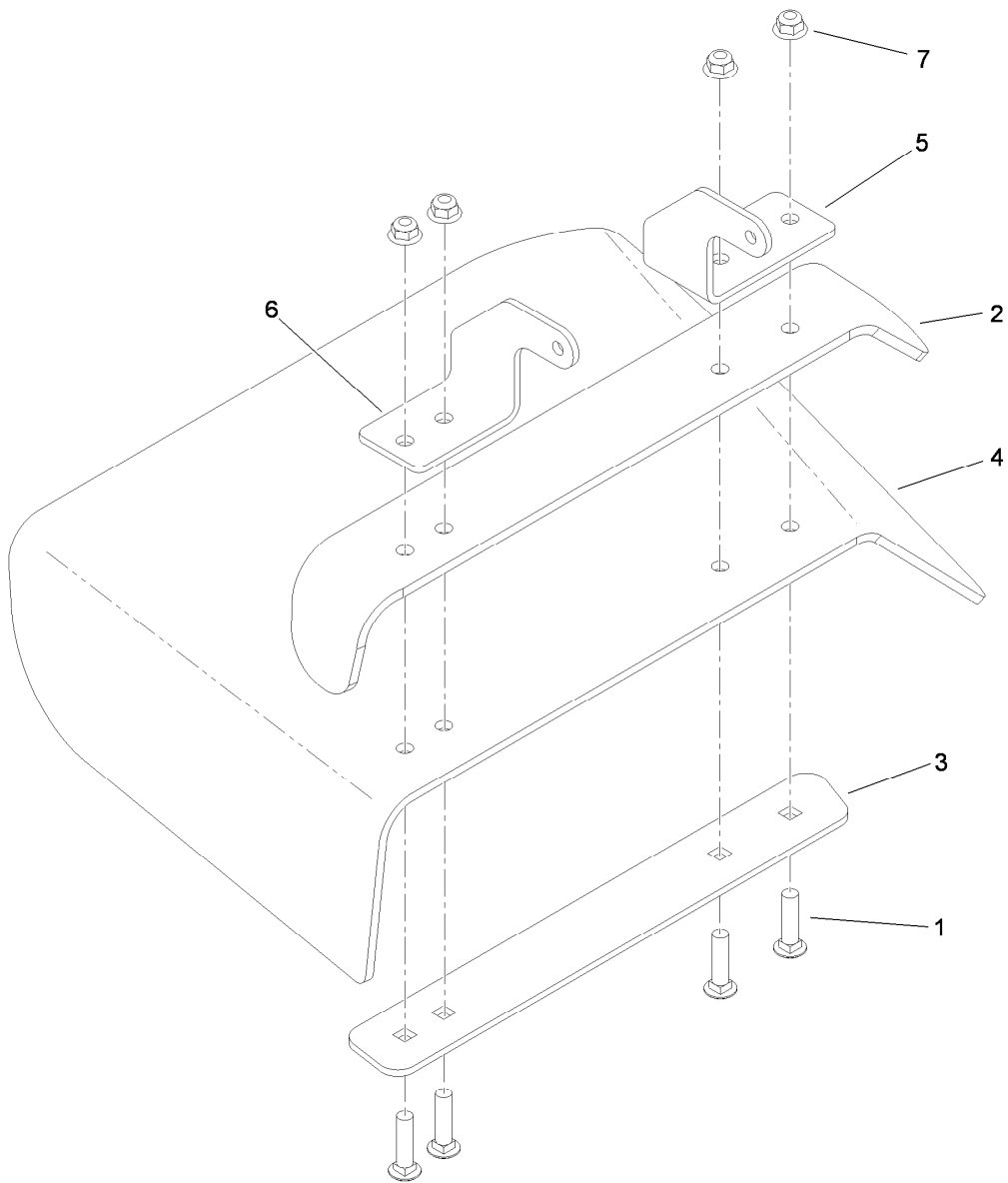

## Deflector Assembly No. 110-0758

<i>Ref.</i>	<i>Part Number</i>	<i>Qty.</i>	<i>Description</i>
1	3231-4	4	Screw-CARR
2	106-3246-01	1	Deflector
3	106-3248-03	1	Strap-Discharge
4	110-0759	1	Deflector-Rubber
5	107-4197-01	1	Bracket-Hinge, Rear
6	107-4196-01	1	Bracket-Hinge, Front
7	104-8301	4	Nut-Flange, NI

# Attachments and Accessories

## For 39078 Commercial Walk-Behind Mower Floating Deck, T-Bar, Gear Drive with 48in TURBO FORCE Cutting Unit

<b>Product Name</b>	<b>Model/Part</b>
Blade-Low Flow, 16.5in.....	107-3193-03
Blade-Mid Flow, 16.5in .....	107-3194-03
Blade-Atomic, 16.5in .....	107-3195-03
Blade-Recycling, 16.5in.....	107-3196-03
Bagging Enhancement Kit .....	108-4091
Blade-Hi Flow, 16.5in (6 Pack).....	110-0414
Blade-Lo Flow, 16.5in (6 Pack) .....	110-0415
Blade-Recycler, 16.5in (6 Pack).....	110-0416
Blade-Atomic, 16.5in (6 Pack) .....	110-0417
Blade-Mid Flow, 16.5in (6 Pack) .....	110-0418
48in Recycler Kit.....	110-2060
Weight-Cast.....	112-7059-01
Weight Kit .....	112-9971
Trim Side Anti-Scalp Roller Kit.....	115-1015
Discharge Side Anti-Scalp Roller Kit.....	115-1016
Soft Bag (3 Bushel).....	30104
Tru Trak Sulky.....	30110



**Count on it.**