



**Proline**

**15 HP Kohler Mid-Size  
Hydro Traction Unit**

**Model No. 30187 – 795101 & Up**

---

**Parts Catalog**

## ORDERING REPLACEMENT PARTS

To order replacement parts, please supply: the part number, the quantity, and the description of each part desired.

## Contents

Description	Page	Description	Page
Engine & Oil Cooler .....	1	Blower Housing And Baffles .....	12
Pivot & Linkage .....	2	Starter System .....	13
Handle Assembly .....	3	Fuel System .....	14
Control Panel Assembly .....	4	Engine Controls .....	15
Fuel Tank, Hydro Pump & PTO .....	5	Air Cleaner .....	16
Hydraulic & Drive System .....	6	Exhaust .....	17
Battery .....	7	Hydraulic Pump Assembly No. 95-1538 .....	19
Crankcase .....	8	Traction Drive Motor (Torquemotor .....	20
Oil Pan / Lubrication .....	9	Electric Schematic .....	21
Cylinder Head, Valves And Breather .....	10	Hydraulic Schematic .....	22
Ignition / Electrical .....	11	<b>Note:</b>	

## Part Description Abbreviations

Part descriptions in this catalog may include the following abbreviations.

Abbreviation	Meaning	Abbreviation	Meaning
AR .....	as required	HWHTF .....	hex washer head thread forming
ASM .....	assembly	INC .....	incorporated
CARR .....	carriage	LH .....	left hand
DEG .....	degrees	PH .....	pan head
FH .....	flat head	PPH .....	Phillips pan head
GA .....	gauge	PTO .....	power take off
HF .....	hex flange	RH .....	right hand
HFV .....	hex flange washer	SFH .....	slotted fillister head
HH .....	hex head	SH .....	square head
HHF .....	hex head flange	SHWH .....	slotted hex washer head
HHST .....	hex head self tapping	SPH .....	slotted pan head
HJ .....	hex jam	STD .....	standard
HOC .....	height-of-cut	TAP .....	self tapping
HS .....	hex socket	TH .....	truss head
HSBH .....	hex socket button head	TTH .....	Torx truss head
HSFH .....	hex socket flat head	WH .....	wing head
HSH .....	hex socket head		
HWH .....	hex washer head		

## Important Format Explanations

This catalog uses special formats to convey information in illustrations and parts lists. Specifically, one format is used in conjunction with service assemblies and another with quantities associated with reference numbers.

## Service Assemblies

Parts within service assemblies have reference numbers in the form  $X:Y$ .  $X$  is the reference number of the service assembly and  $Y$  is a sequential number unique to each part within the service assembly.

For example, a wheel assembly might be identified by reference number 6, the tire by 6:1, the valve by 6:2, and the wheel by 6:3. When you order the assembly identified by reference number 6, you receive all parts identified by reference numbers 6:1, 6:2, and 6:3. However, you may also order any part individually.

Reference numbers of this type appear in part lists and as callouts in illustrations.

## Reference Numbers with Quantities

Illustrations may have a quantity in parentheses next to a reference number, in the form  $X (Y)$ .  $X$  is the reference number.  $Y$  in parentheses is the quantity of the part identified by the reference number.

For example, the illustration callout 4 (2) indicates that two parts are used in that instance.

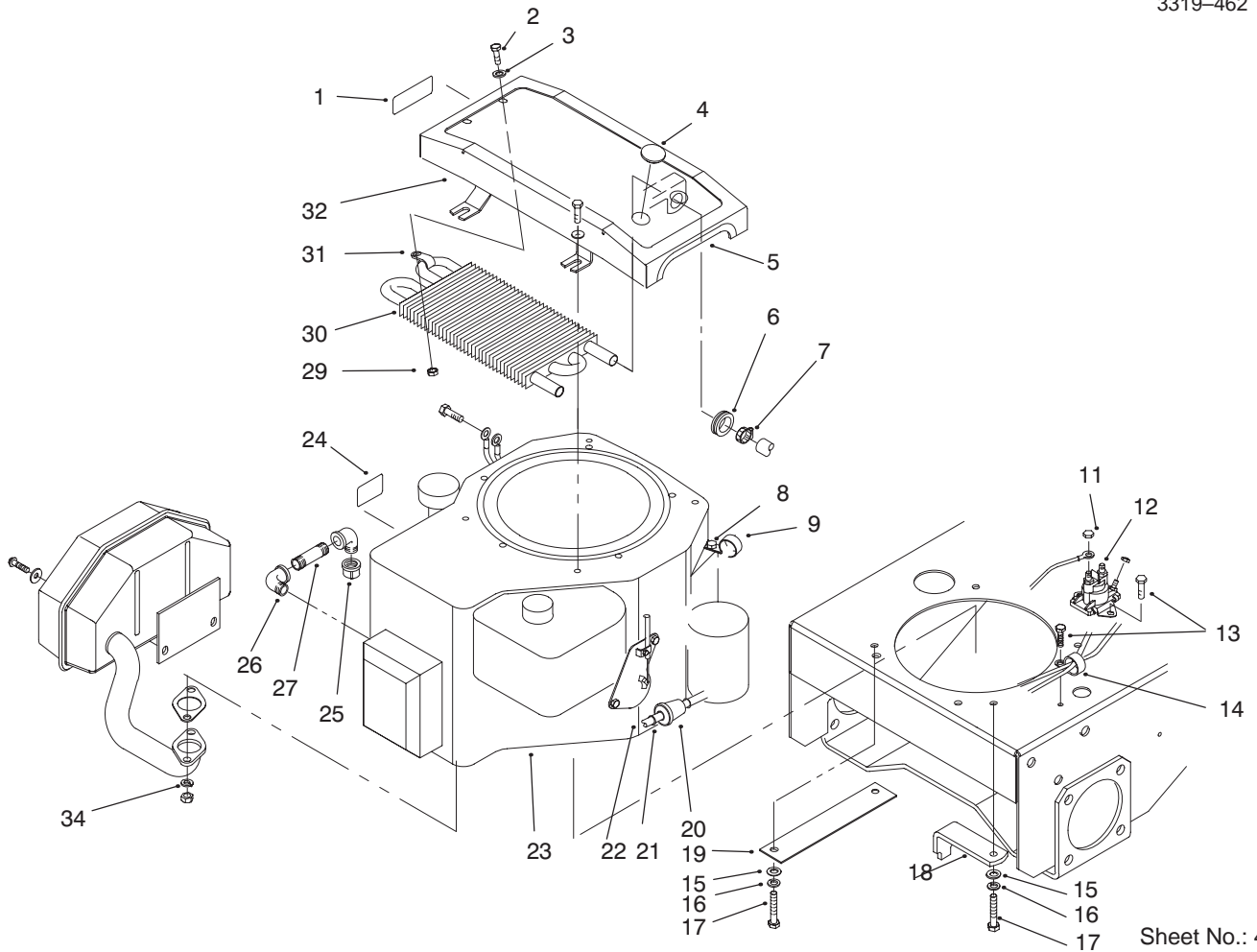

Sheet No.: 4

## Engine & Oil Cooler

Ref. No.	Part No.	Qty.	Description
1	95-2814	1	Decal-Fuel Shut-Off
2	3256-1	6	Washer-Flat
3	321-39	6	Screw-HH
4	2410-71	2	Cap-Plug
5	29-0642	1	Jiffy-Trim
6	240-9	2	Grommet
7	2412-136	2	Clamp
8	32104-76	1	Screw-Self TAP
9	2412-106	1	R Clamp
11	32149-2	2	Nut-Hex Lock
12	92-9845	1	Solenoid
13	32144-4	3	Screw-TAP
14	2412-106	1	R Clamp
15	3256-23	4	Washer-Flat
16	3253-4	A/R	Washer-Lock
17	57-6380	4	Screw-HH
18	51-4540-03	1	Retainer-Clutch
19	74-0930-01	1	Guard-Pulley
20	56-6360	1	Filter-Fuel
21	2412-98	2	Clamp-Hose
22	47-2964	1	Hose-Gas
23		1	Engine-15 Hp Kohler
24	63-8440	1	Decal-Hot Surface
25	288-4	1	Cap-Pipe
26	74-0950	2	Elbow
27	289-51	1	Nipple-Pipe

Ref. No.	Part No.	Qty.	Description
29	3296-42	2	Nut-Lock
30	82-4220	1	Cooler-Oil
31	2412-134	2	Clamp R
32	82-4500-03	1	Mount-Cooler

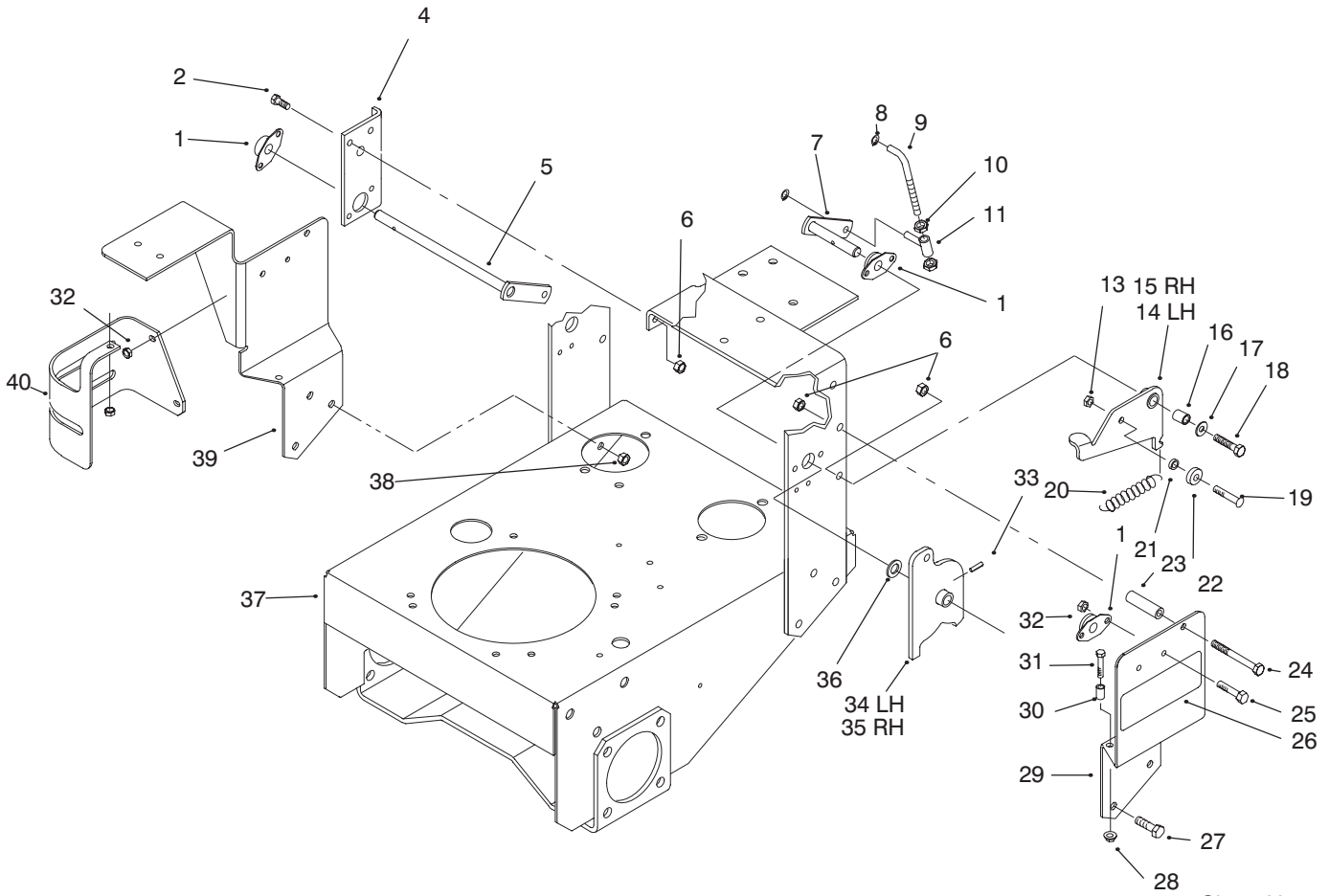

Sheet No.: 5

## Pivot & Linkage

Ref. No.	Part No.	Qty.	Description
1	82-4130	4	Bearing
2	322-5	2	Screw-HH
3	3290-378	A/R	Tie-Cable
4	82-4210-01	1	Bracket-Bushing
5	94-9059	1	Lever-Pivot RH
6	3296-29	6	Nut-Lock
7	94-9057	1	Lever-Pivot LH
8	32151-3	4	Ring-Retaining
9	94-9093	2	Rod-Link
10	3218-2	4	Nut-Hex Jam
11	94-9062	2	Sleeve
13	3296-47	2	Nut-Lock
14	82-4330-01	1	Arm-Detent LH
15	82-4340-01	1	Arm-Detent RH
16	82-4370	2	Bushing-Arm
17	3256-23	2	Washer-Flat
18	322-7	2	Screw-HH
19	3274-32	2	Screw-HH
20	82-4160	2	Spring-Detent
21	82-4240	2	Spacer-Bearing
22	251-259	2	Bearing-Ball
23	82-3920	2	Stop-Reverse
24	322-14	2	Screw-HH
25	321-3	11	Screw-HH
26	82-4600	2	Decal-Hydro
27	323-6	6	Screw-HH

Ref. No.	Part No.	Qty.	Description
28	32128-10	2	Nut-Lock HHF
29	95-1530-01	1	Bracket-Pivot
30	95-1516	2	Spacer-Tubular
31	321-8	2	Screw-HH
32	3296-42	11	Nut-Lock
33	32121-4	2	Pin-Roll
34	94-9054-01	1	Arm-Pivot LH
35	94-9061-01	1	Arm-Pivot RH
36	257-5	2	Washer-Thrust
37	94-9096-01	1	Frame ASM
38	3296-39	6	Nut-Lock
39	95-1522-01	1	Bracket-Pivot
40	95-5868-01	1	Guard-Filter

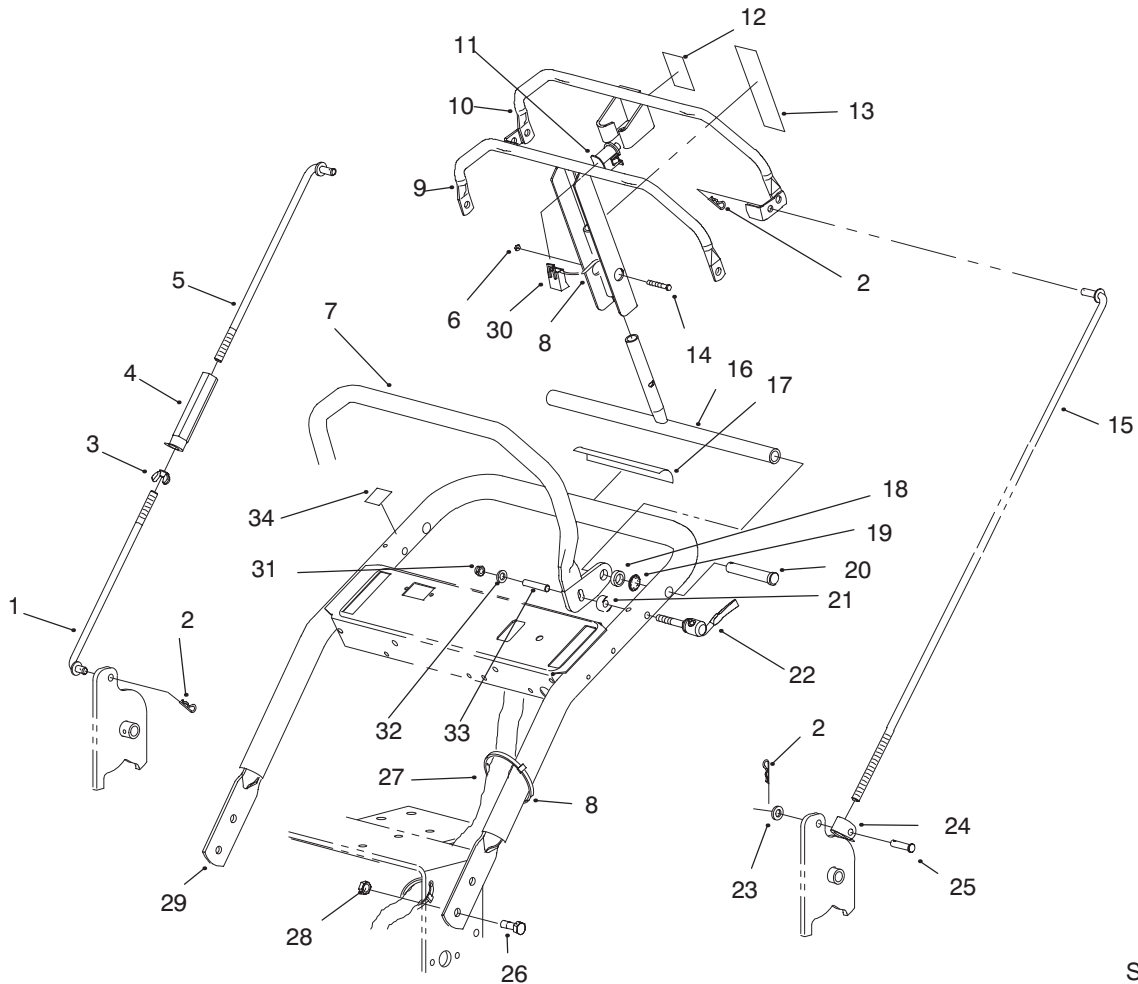

Sheet No.: 6

## Handle Assembly

Ref. No.	Part No.	Qty.	Description	Ref. No.	Part No.	Qty.	Description
1	95-1506	1	Rod-Control	26	3234-11	4	Screw-HHF
2	3290-307	4	Pin-Cotter	27	95-2807	1	Harness-Wire
3	32103-3	1	Nut-Wing	28	32128-21	4	Nut-Hfh
4	95-1504	1	Turnbuckle	29	95-5856-03	1	Handle-Upper
5	95-1505	1	Rod-Control	30	218-595	1	Connector-Body
6	3296-2	1	Nut Lock	31	33023-00	2	Nut-Lock Ni
7	95-1536	1	Handle ASM	32	3290-436	2	Washer-Belleville
8	3290-378	3	Tie-Cable	33	95-5854	2	Sleeve
9	95-1507-03	1	Control Bar ASM	34	95-5862	1	Decal-Speed Lock
10	95-1510-03	1	Bail ASM				
11	82-2190	1	Switch-Bail				
12	95-1523	1	Decal-Traction Drive				
13	95-1524	1	Decal-T Bar				
14	32105-12	1	Screw-Hex				
15	94-9095	1	Rod-Control				
16	95-1513-03	1	Pivot ASM				
17	82-4590	1	Decal-Slope Warning				
18	95-5855-03	2	Spacer-Pivot				
19	32151-80	2	Ring-Push On				
20	283-55	2	Pin-Clevis				
21	82-3840	2	Spacer-Latch				
22	95-5853	2	Lock ASM-Quick Release				
23	3256-23	1	Washer-Flat				
24	74-0521	1	Rod-Fitting				
25	283-6	1	Pin-Clevis				



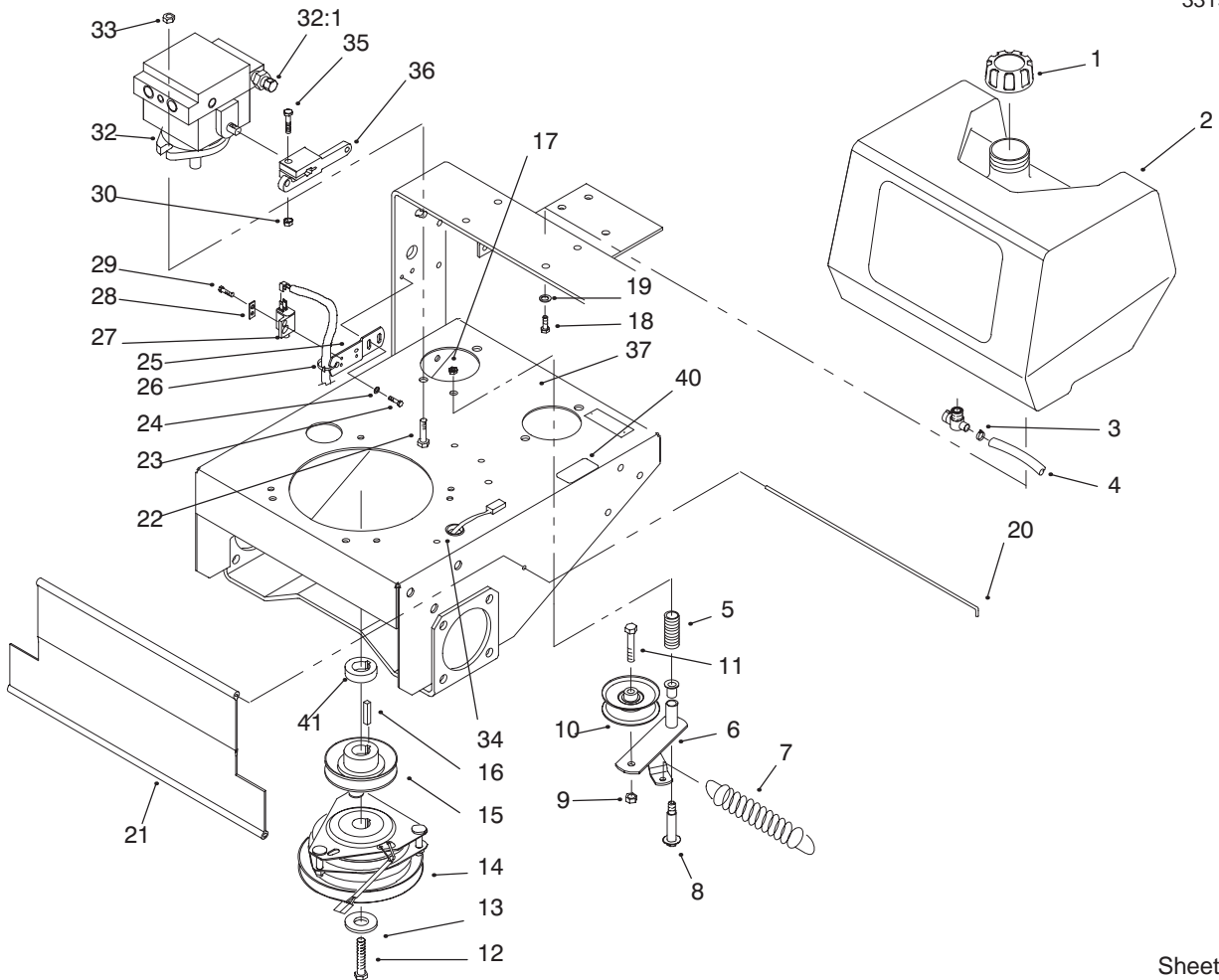

Sheet No.: 8

## Fuel Tank, Hydro Pump & PTO

Ref. No.	Part No.	Qty.	Description
1	55-3570	1	Cap-Fuel
2	95-2802	1	Tank-Fuel
3	2412-98	2	Clamp-Hose
4	47-2982	1	Hose-Fuel
5	88-1880	1	Spring-Compression
6	86-4770-03	1	Lever-Idler
7	68-2190	1	Spring-Extension
8	27-6230	1	Bolt-Wheel
9	3296-39	1	Nut-Lock
10	62-4540-03	1	Pulley-Idler
11	323-9	1	Screw-HH
12	57-6360	1	Screw-HH
13	3219-9	1	Washer-PTO
14	54-3200	1	Clutch ASM
15	44-5940	1	Pulley-Drive
16	608006	1	Key
17	3296-6	1	Nut-Lock
18	322-3	4	Screw-HH
19	3253-4	4	Washer-Lock
20	95-1529	1	Rod-Shield
21	95-1526	1	Trailing Shield
22	324-5	4	Screw-HH
23	32144-3	4	Screw-HWH
24	3256-1	4	Washer-Flat
25	82-4580-03	2	Bracket-Neutral
26	3290-378	2	Tie-Cable

Ref. No.	Part No.	Qty.	Description
27	65-7410	2	Switch-Single Pole
28	82-4570	2	Plate-Switch
29	32144-1	4	Screw-HH
30	3296-29	2	Nut-Lock
32	95-1538	2	Hydraulic Pump ASM
32:1	95-1539	2	Valve ASM
33	32128-42	4	Nut-Hex Flange
34	237-124	1	Grommet
35	322-7	2	Screw-HH
36	82-3790	2	Arm-Control
37	95-1543	1	Decal-Valve Adjust

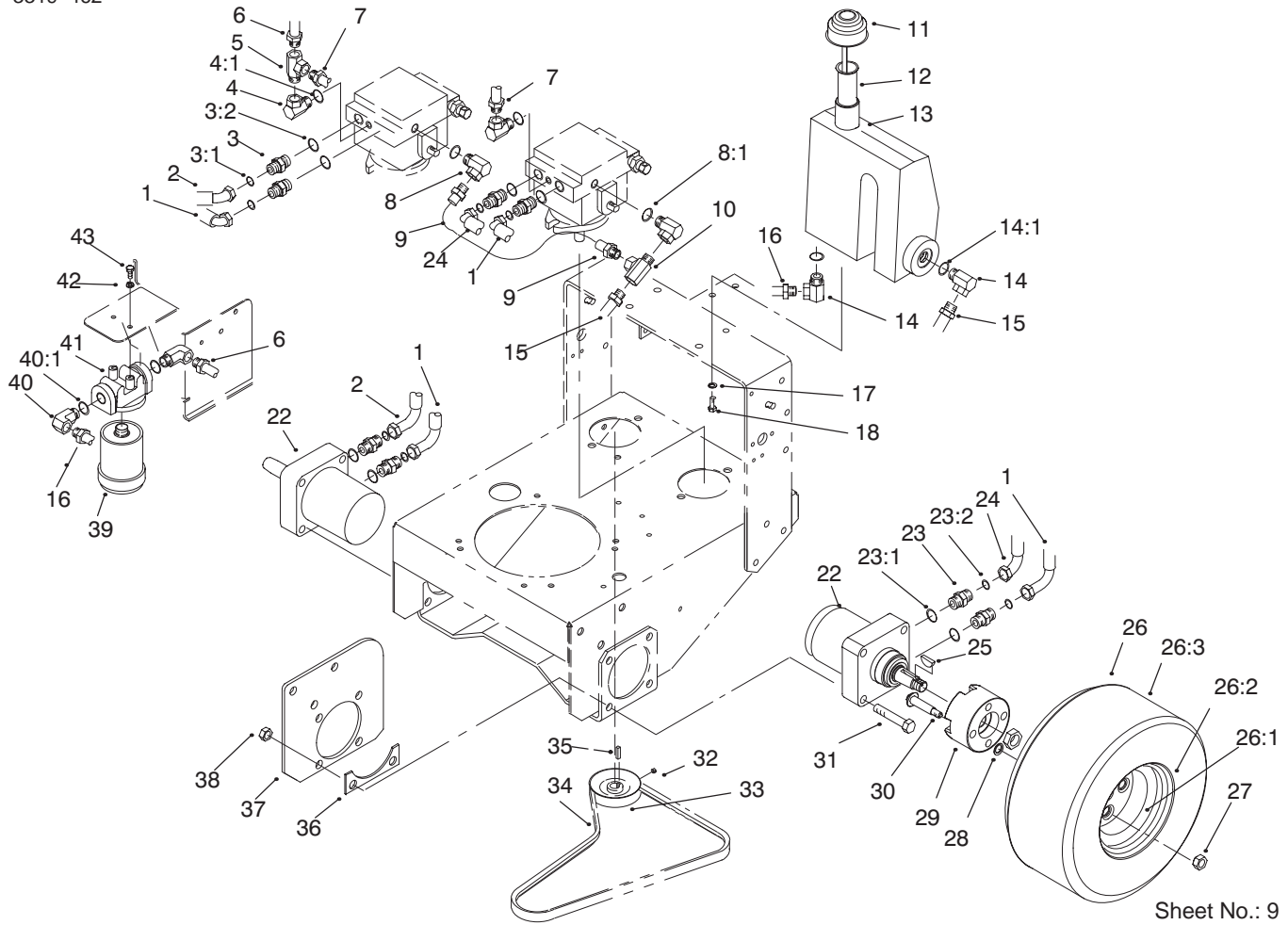

Sheet No.: 9

## Hydraulic & Drive System

Ref. No.	Part No.	Qty.	Description
1	82-4550	2	ASM-Hose
2	82-4540	1	ASM-Hose
3	340-4	4	Fitting-Hydraulic
3:1	237-30	4	O-Ring
3:2	237-79	4	O-Ring
4	354-116	2	Fitting-Hydraulic
5	2815-16	1	Fitting-Hydraulic
6	82-4180	1	ASM-Hose
7	82-4170	1	ASM-Hose
8	354-115	2	Fitting-Hydraulic
8:1	237-42	A/R	O-Ring
9	82-4201	1	ASM-Hose
10	2815-15	1	Fitting-Hydraulic
11	76-0200	1	Oil Cap ASM
12	29-0590	1	Screen-Filler
13	95-1532	1	Reservoir-Oil
14	354-118	2	Fitting-Hydraulic
15	82-4192	2	ASM-Hose
16	82-4200	1	ASM-Hose
17	3253-4	3	Washer-Lock
18	322-3	3	Screw-HH
22	82-8230	2	Motor-Wheel
23	340-6	4	Fitting-Hydraulic
23:1	237-80	4	O-Ring
23:2	237-30	4	O-Ring
24	82-4560	1	ASM-Hose

Ref. No.	Part No.	Qty.	Description
25	3257-8	2	Key-Woodruff
26	94-9664	2	ASM-Wheel & Tire
26:1	232-27	2	Valve Stem & Cap Assembly
26:2	242-87	2	Wheel
26:3	231-117	2	Tire-15x6
27	242-50	8	Nut-Lug
28	32112-17	8	Pushnut
29	82-3830	2	Hub-Wheel
30	3213-8	8	Screw-HH
31	325-11	8	Screw-HH
32	3241-5	4	Set Screw
33	95-1528	2	Pulley-Pump
34	82-4110	1	V Belt
35	80-6090	2	Key-Square
36	86-4740-01	2	Spacer-Frame
37	86-4730-01	2	Plate-Frame
38	3296-23	8	Nut-Lock
39	67-8110	2	Filter-Oil
40	354-117	2	Fitting-Hydraulic
40:1	237-79	2	O-Ring
41	86-9080	1	Head-Filter
42	3253-3	2	Washer-Lock
43	321-3	2	Screw-HH



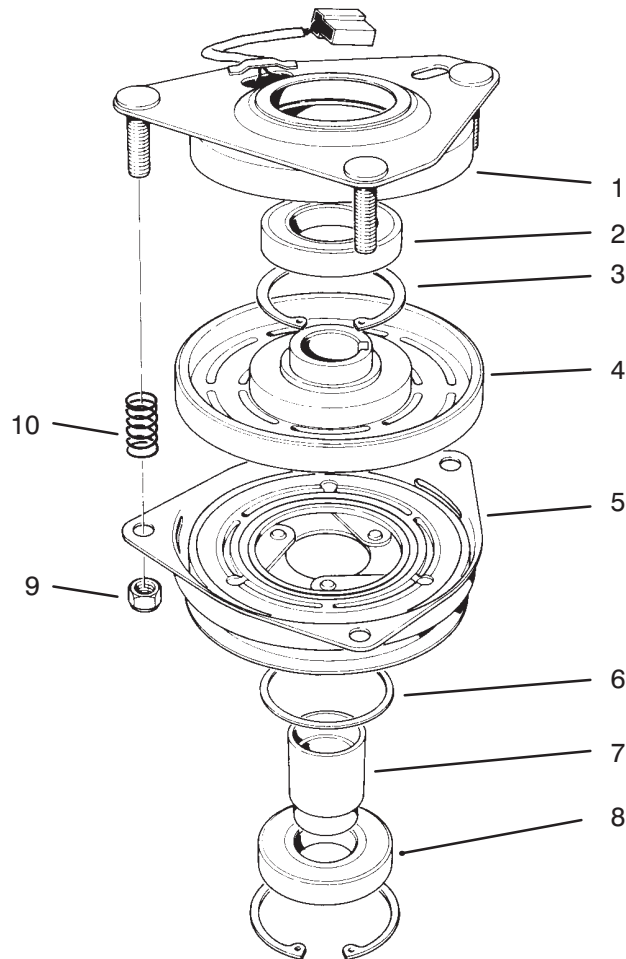

T-0080

## CLUTCH ASSEMBLY NO. 54-3200

Ref. No.	Part No.	Description	No. Used	Ref. No.	Part No.	Description	No. Used
1	54-0230	Field Ass'y (Incl. Ref. #2 & 3)	1	6	44-8330	Spacer	1
2	251-292	Bearing - Field	1	7	44-8340	Collar - Bearing	1
3	44-8310	Ring - Retaining	2	8	251-291	Bearing - Pulley	1
4	44-8360	Field Coil, Rotor & Bearing Assembly (Incl. Ref. #1)	1	9	3296-5	Nut - Lock	3
5	55-7410	Armature & Pulley Assemble (Incl. Ref. #3,6,7, & 8)	1	10	44-8320	Spring	3

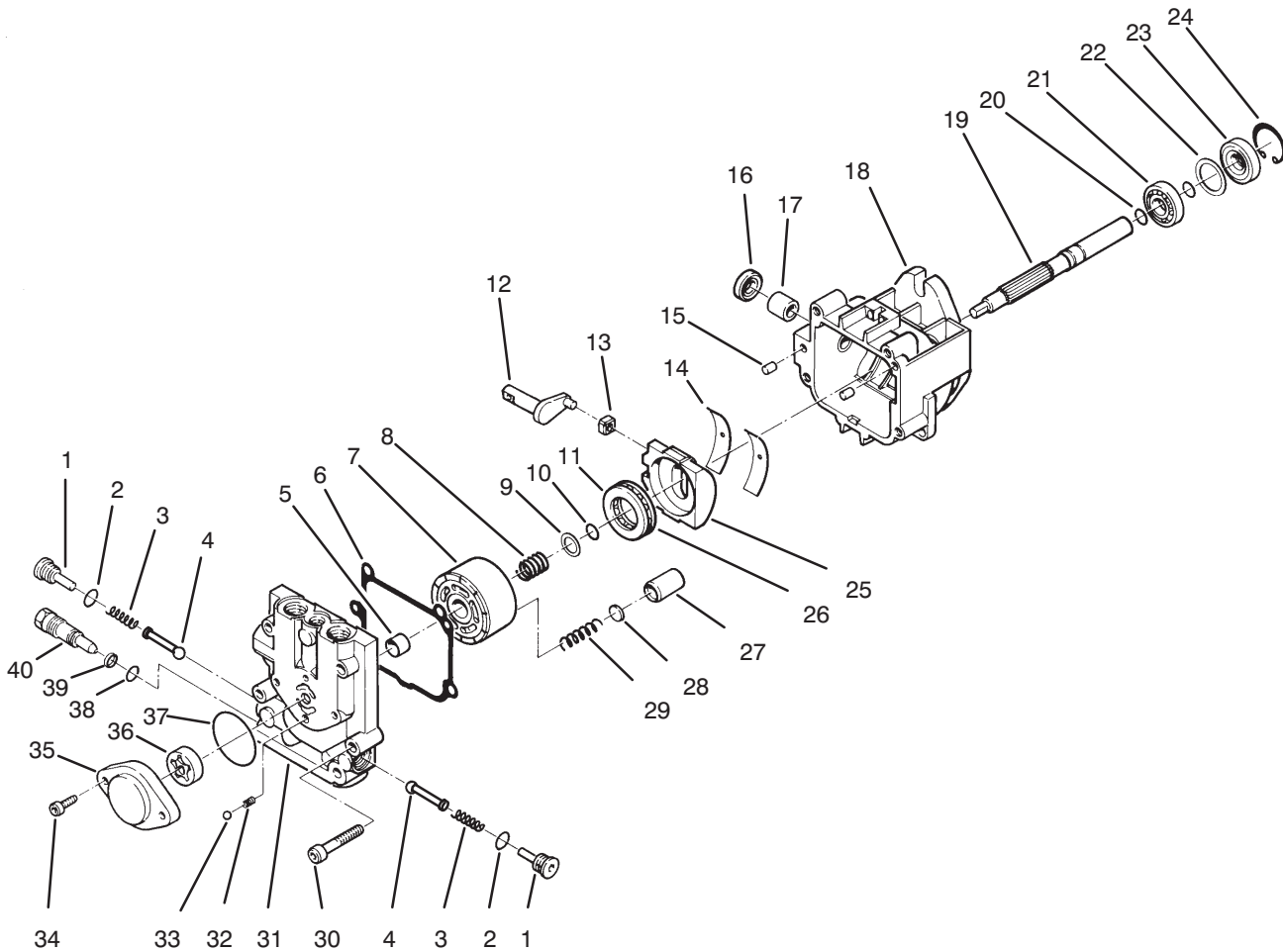

T-1236

## Hydraulic Pump Assembly No. 95-1538

Ref. No.	Part No.	Description	No. Used
	82-6120	Check Valve Kit (Incl. Ref. #2-4)	1
2		Seal - O-Ring	2
3		Spring	2
4		Poppet	2
5		Journal - Bearing	1
6		Gasket - End Cap	1
7		Cylinder Block Kit (Incl. Ref. #8-10 & 27-29)	1
8		Spring	1
9		Washer	1
10		Ring - Retaining	1
11		Plate - Thrust	1
12		Arm - Trunnion	1
13		Guide - Slot	1
14		Cradle - Bearing	2
15		Pin	2
16		Seal - Lip	1
17		Journal - Bearing	1
18		Housing - Assembly (Incl. Ref. #16 & 17)	1
19		Shaft	1
20		Ring - Retaining	2
21		Bearing - Ball	1
22		Spacer	1

Ref. No.	Part No.	Description	No. Used
23		Seal - Lip	1
24		Ring - Retaining	1
25		Swashplate Assembly	1
26		Roller - Thrust	1
27		Piston	5
28		Washer - Thrust	5
29		Spring - Piston	5
30		Screw	4
31		End Cap Assembly (Incl. Ref. #5)	1
32		Ball	1
33		Spring	1
34		Screw	2
35		Housing - Charge Pump	1
36		Gerotor Assembly	1
37		Seal - O-Ring	1
38		Seal - O-Ring	1
39		Ring - Back-Up	1
40		Valve - Bypass	1
*	80-6110	Charge Relief Valve Kit (Incl. Ref. #32-33)	1
*	80-6130	Overhaul Seal Kit (Incl. Ref. #6, 10, 16, 20, 23 & 37-39)	1

\*Not Illustrated

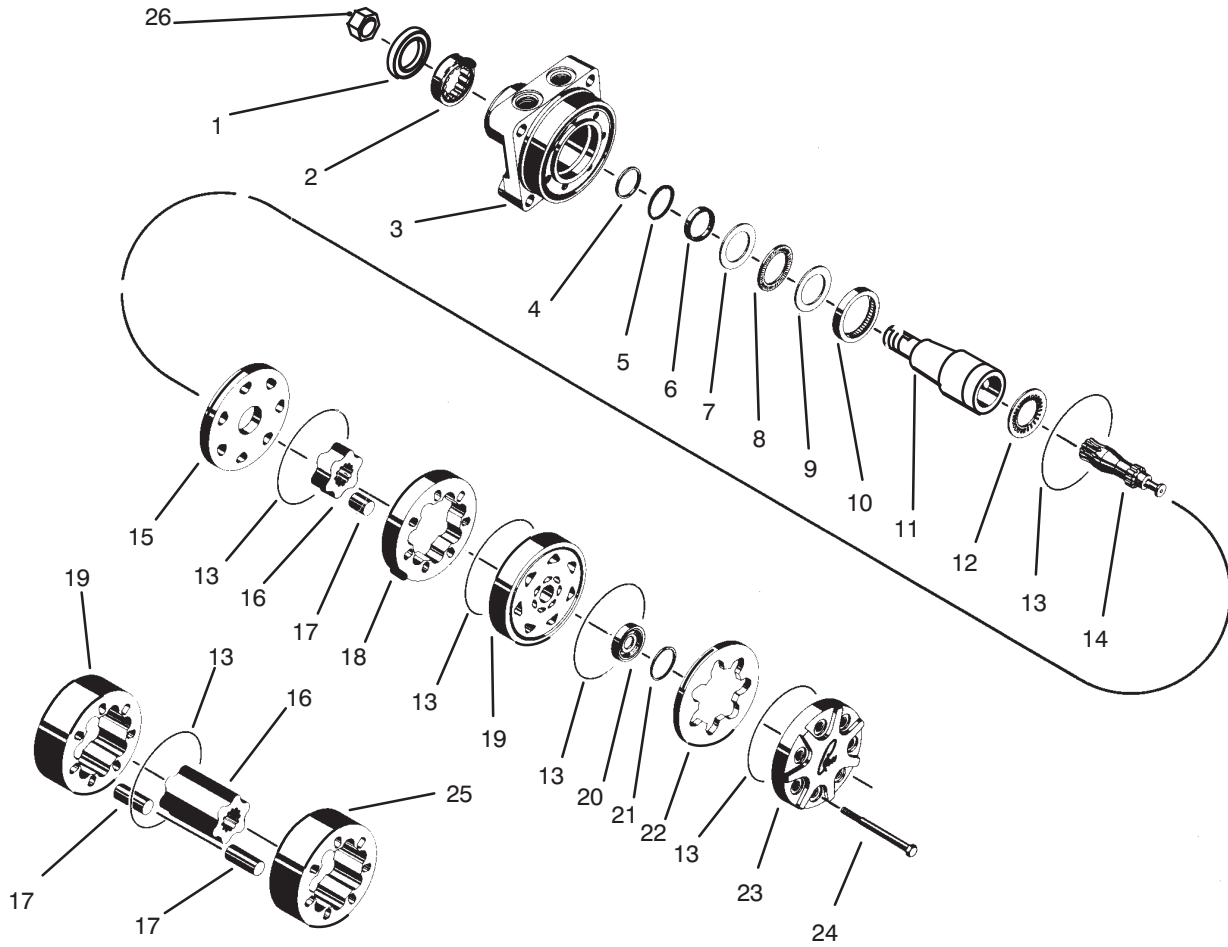

C-0737

## Traction Drive Motor (Torquemotor)

Ref. No.	Part No.	Description	No. Used
1		Seal	1
2		Bearing	1
3		Housing	1
4		Washer - Back Up	1
5		Washer - Back Up	1
6		Seal	1
7		Washer - Thrust	1
8		Bearing - Thrust	1
9		Washer - Thrust	1
10		Bearing - Inner	1
11		Coupling - Shaft	1
12		Bearing - Thrust	1
13		"O"Ring	5
14		Link - Drive	1

Ref. No.	Part No.	Description	No. Used
15		Plate Wear	1
16		Rotor	1
17		Vane	7
18		Stator	
19		Manifold	1
20		Commutator	1
21		Seal - Commutator	1
22		Commutator - Ring	1
23		Cover - End	1
24		Bolt - Special	A/R
25		Stator Half	
26	85-7310	Nut	1
*	85-7320	Kit - Seal (Incl. Ref. #1,4,6,13 & 20)	1

\*Not Illustrated

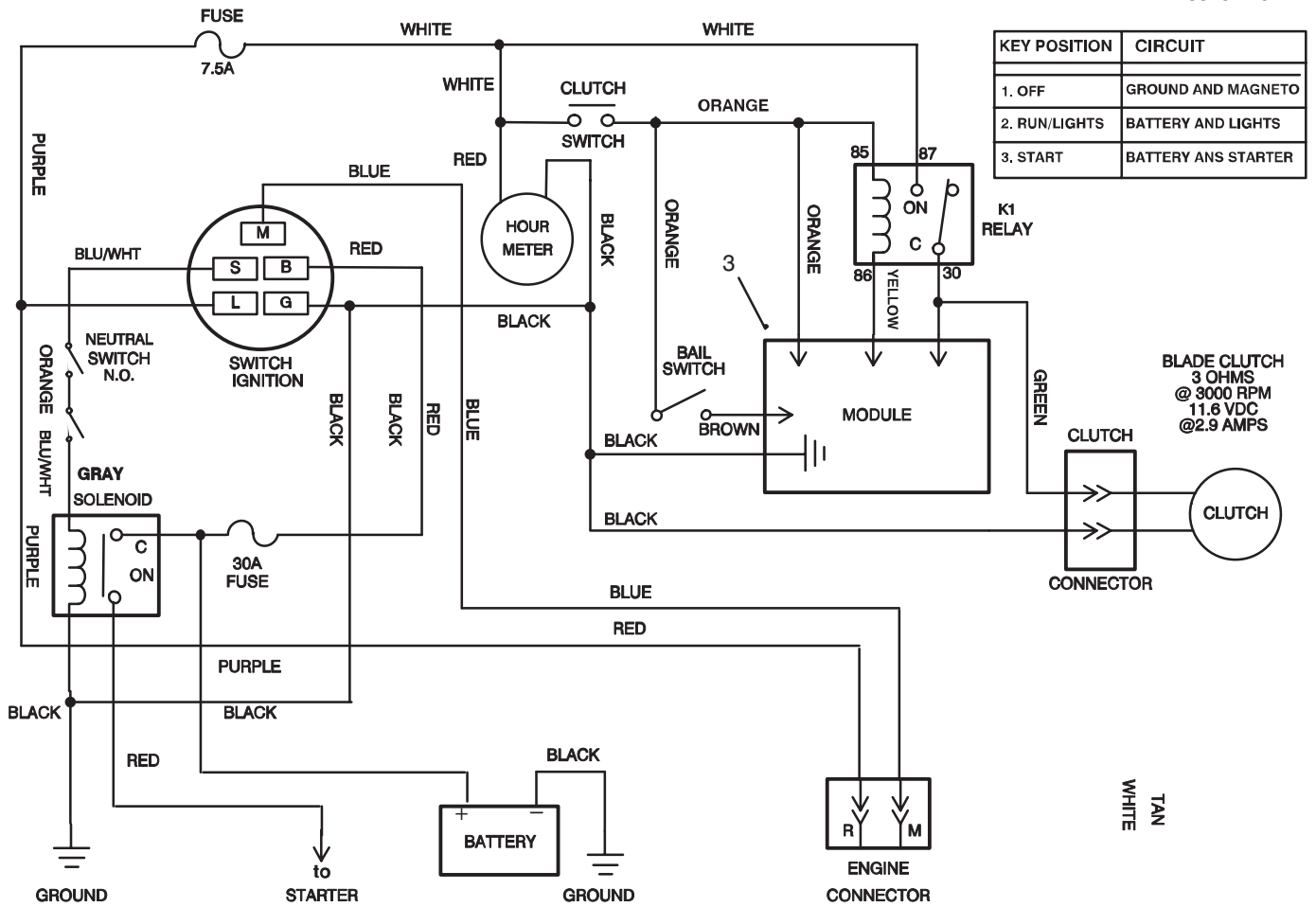

### Electric Schematic

Ref. No.	Part No.	Description	No. Used
1	95-2807	Wire Harness (Ref.)	1
2	63-7590	Relay (Ref.)	1

Ref. No.	Part No.	Description	No. Used
3	94-9666	Interlock Module (Ref.)	1

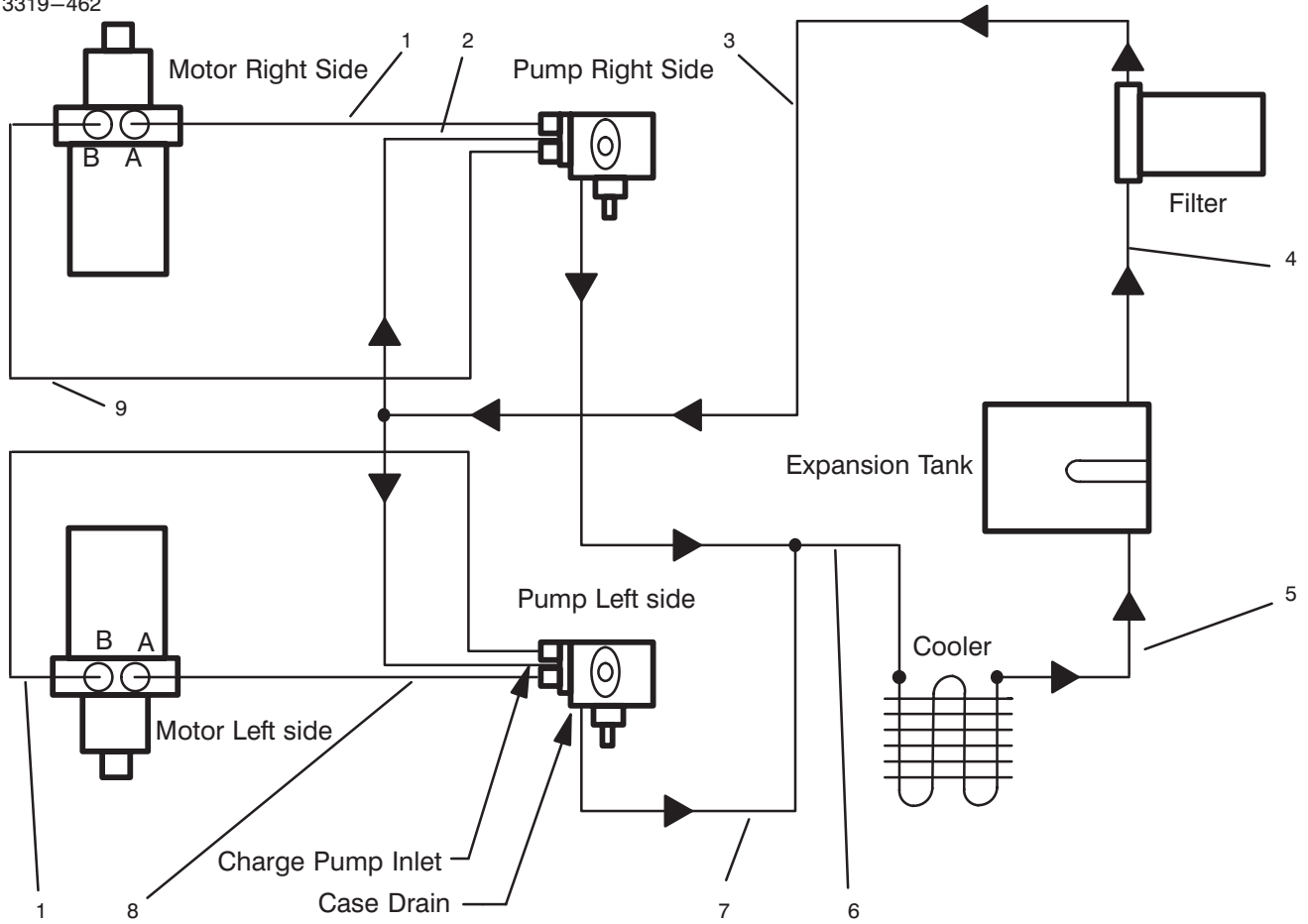

### Hydraulic Schematic

Ref. No.	Part No.	Description	No. Used
1	82-4550	Hose Assembly	2
2	82-4170	Hose Assembly	1
3	82-4180	Hose Assembly	1
4	82-4200	Hose Assembly	1
5	82-4193	Hose Assembly	1

Ref. No.	Part No.	Description	No. Used
6	82-4192	Hose Assembly	1
7	82-4201	Hose Assembly	1
8	82-4560	Hose Assembly	1
9	82-4540	Hose Assembly	1

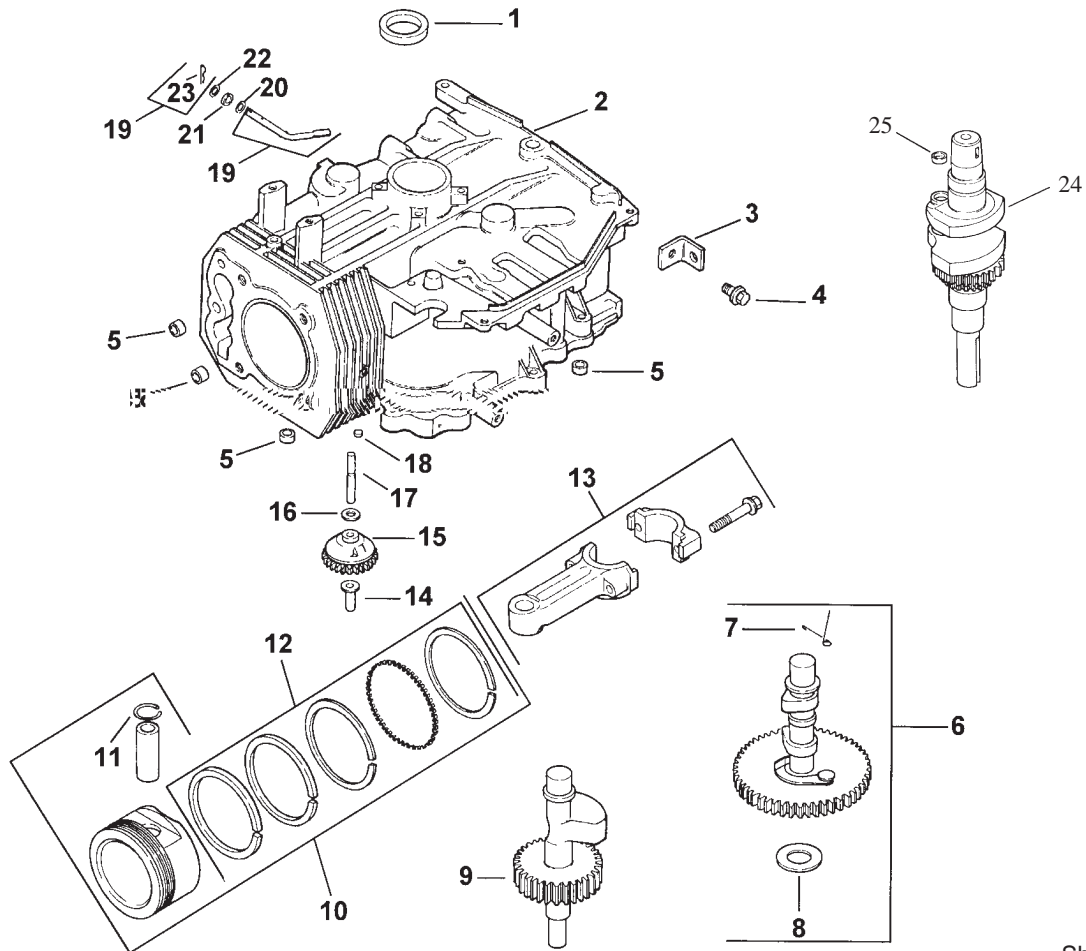

Sheet No.: 2 01

## Crankcase

Ref. No.	Part No.	Qty.	Description
1	12 032 03	1	Seal-Crankshaft
2	12 522 18	1	Shortblock
3	12 445 02	1	Strap-Lifting
4	M-0839025	1	Screw M8x1.25x22
5	12 380 17	4	Dowel-Locating
6	12 755 49	1	Kit-Camshaft INC 7-8
7	12 089 18	1	Spring-Actuating
8	12 422 07	A/R	Shim-Camshaft A/R
8	12 422 08	1	Shim-Camshaft A/R
8	12 422 09	A/R	Shim-Camshaft A/R
8	12 422 10	A/R	Shim-Camshaft A/R
8	12 422 11	A/R	Shim-Camshaft A/R
8	12 422 12	A/R	Shim-Camshaft A/R
8	12 422 13	A/R	Shim-Camshaft A/R
9	12 144 27	1	Shaft-Balance
10	12 847 07	1	Set Piston w/Ring STD
10	12 847 08	1	Set-Piston w/Ring .25
10	12 847 09	1	Set-Piston w/Ring .50
11	12 018 02	2	Retainer-Piston Pin
12	12 108 07	1	Ring Set STD
12	12 108 08	1	Ring Set .25
12	12 108 09	1	Ring Set .50
13	12 067 05	1	Rod Connecting STD
13	12 067 06	1	Rod Connecting .25

Ref. No.	Part No.	Qty.	Description
14	12 380 01	1	Pin-Governor Regulating
15	12 043 05	1	Gear-Governor ASM
16	M-0631005	1	Washer-Governor
17	12 144 02	1	Shaft-Governor Gear
18	52 139 09	1	Plug-Cup
19	12 755 64	1	Kit - Shaft-Governor Cross (Incl. Ref.#23)
20	X-25-102	1	Washer-Flat
21	12 032 01	1	Seal-Governor Shaft
22	M-0631015	1	Washer-Governor Shaft
23	12 154 05	1	Clip - Hitch Pin
24	12 014 30	1	Crankshaft ASM
25	12 139 01	1	Plug-Cup
*	12 030 02	1	Bearing - Crankshaft 0.25
*	12 030 03	1	Bearing - Crankshaft 0.50
*	12 755 82	1	Set - Gasket

\* Not Illustrated

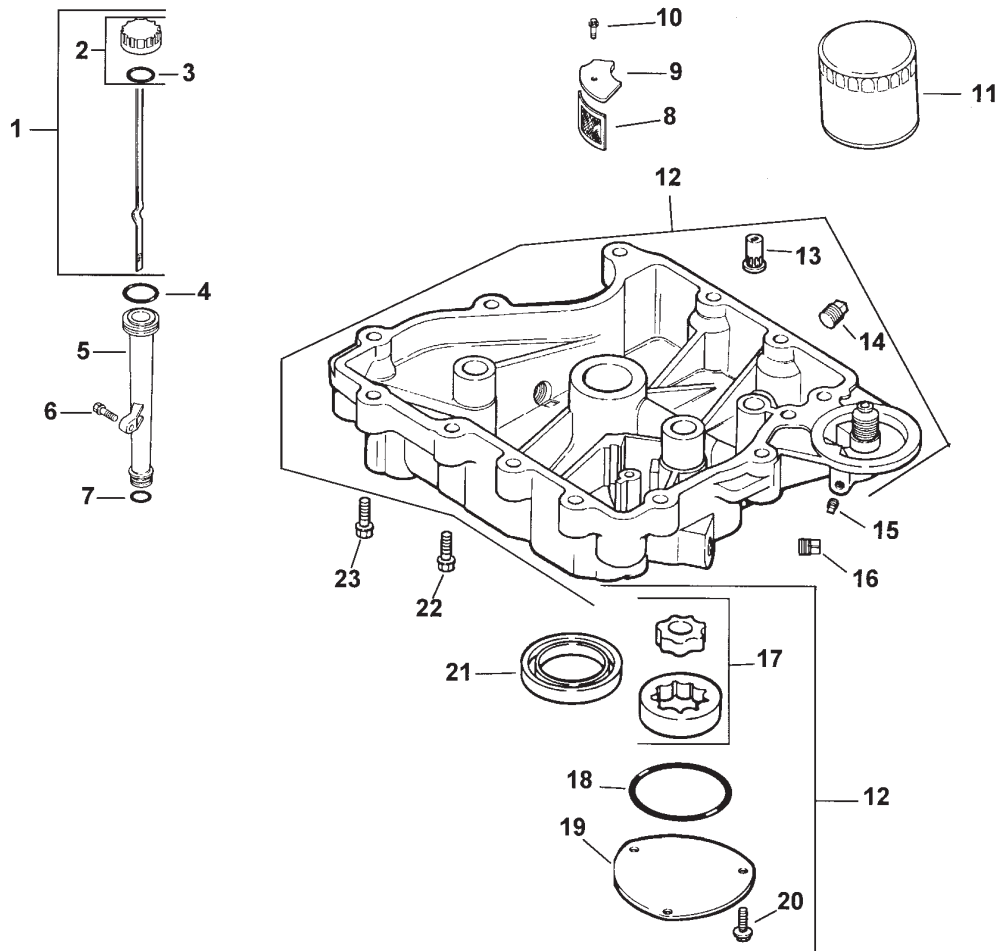

Sheet No.: 2 02

## Oil Pan / Lubrication

Ref. No.	Part No.	Qty.	Description
1	12 038 01	1	Dipstick INC 2-3
2	25 755 13	1	Kit-Oil Cap INC 3
3	12 153 03	1	O Ring-Fill Cap
4	12 153 02	1	O Ring-Upper Fill Tube
5	12 123 04	1	Tube-Oil Fill
6	M-0545020	1	Screw M5x0.8x20
7	12 153 01	2	O Ring-Lower Fill Tube
8	25 162 07	1	Screen-Oil
9	12 096 03	1	Cover-Oil Pickup Screen
10	M-0545016	1	Screw M5x0.8x16
11	52 050 02	1	Filter-Oil
12	12 199 45	1	Pan - Oil (Incl. Ref. #13, 14, 17-20)
13	25 462 09	1	Valve - Oil Pressure
14	X-75-2	2	Plug-1/4nptf
15	X-75-1	2	Plug-1/8nptf
16	X-75-10	2	Plug-SH 3/8 NPTF
17	12 393 01	1	Pump-Oil
18	12 153 06	1	O Ring-Oil Pump Cover
19	12 096 34	1	Cover-Oil Pump
20	M-0545016	3	Screw M5x0.8x16
21	12 032 03	1	Seal-Crankshaft

Ref. No.	Part No.	Qty.	Description
22	24 086 16	11	Screw-M8X1.25X45
23	24 068 17	1	Screw-M5X1.25X45

\* Not illustrated

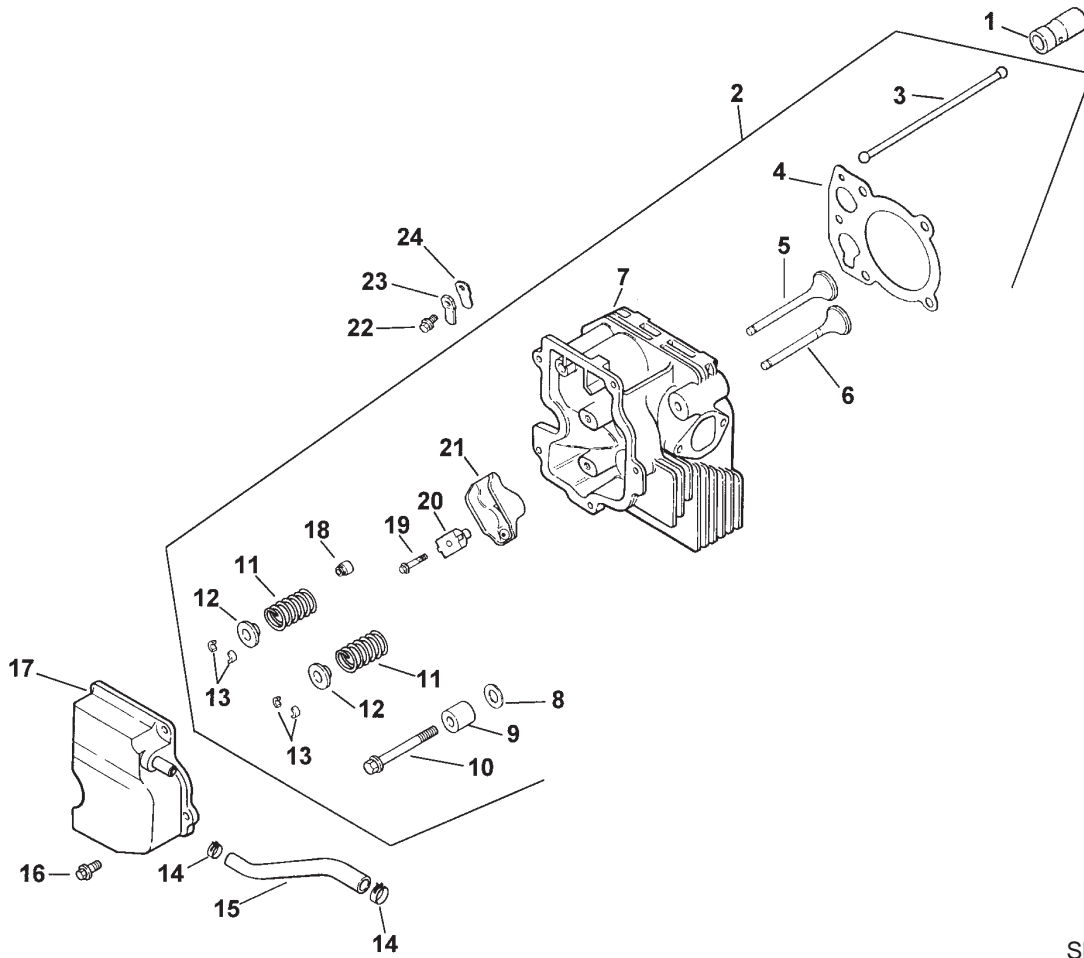

Sheet No.: 2 03

## Cylinder Head, Valves And Breather

Ref. No.	Part No.	Qty.	Description
1	12 351 02	2	Lifter-Valve
2	12 755 81	1	Kit-Cylinder Head
3	12 411 01	2	Rod-Push
4	12 041 10	1	Gasket-Cylinder Head
5	12 017 01	1	Valve-Intake STD
5	12 017 02	1	Valve-Intake .25
6	12 016 01	1	Valve-Exhaust STD
6	12 016 02	1	Valve-Exhaust .25
7	12 318 19	1	Head - Cylinder
8	12 468 05	1	Washer-Flat
9	12 112 13	1	Spacer-Head Bolt Exhaust
10	12 086 15	5	Screw M10x1.5x80
11	12 089 01	1	Spring-Valve
12	12 173 01	2	Cap-Valve Spring
13	12 755 03	2	Kit-Retainer
14	X-426-9	2	Clamp-Hose
15	12 326 03	1	Hose-Breather
16	M-0645020	3	Screw-HH M6x1.0x20
17	12 096 07	1	Cover-Valve w/Nipple
18	24 023 05	1	Seal-Valve Spring
19	M-0640034	2	Screw M6x1.0x34
20	12 599 03	2	Pivot - Rocker Arm
21	25 186 01	2	Arm-Rocker
22	M-0545010	1	Screw M5x0.8x10

Ref. No.	Part No.	Qty.	Description
23	12 018 01	1	Retainer-Breather Reed
24	12 402 02	1	Reed-Breather

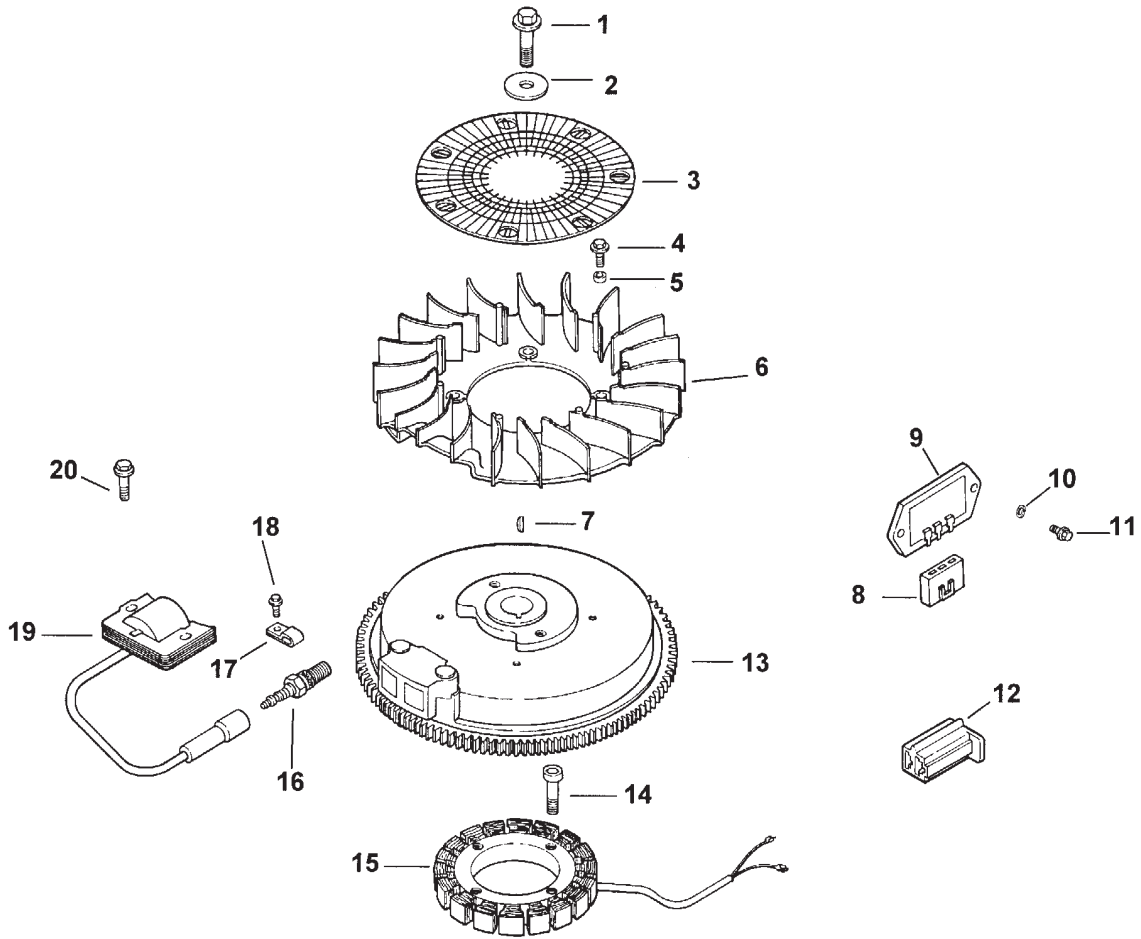

Sheet No.: 2 04

### Ignition / Electrical

Ref. No.	Part No.	Qty.	Description
1	12 086 14	1	Screw-Flywheel Mounting
2	12 486 03	1	Washer-Flat
3	12 162 03	1	Screen-Grass
4	M-0639016	4	Screw M6x1.0x16
5	12 112 01	4	Spacer-Fan
6	12 157 02	1	Fan
7	X-42-15	1	Key
8	236602	1	Connector-Regulator
9	12 403 01	1	Rectifier-Unregulated
10	X-22-11	2	Washer - Lock
11	M-0639016	2	Screw M6x1.0x16
12	41 155 03	1	Connector
13	12 025 33	1	Flywheel ASM
14	M-0548025	4	Screw M5x0.8x25
15	54 755 09	1	Kit - Stator-15 Amp (Incl. Bracket P/N #24 126 71)
16	12 132 02	1	Spark Plug
17	X-728-1	2	Clip-Kill Lead
18	M-0545010	1	Screw M5x0.8x10
19	12 584 02	1	Module-Ignition
20	M-0545020	2	Screw M5x0.8x20
*	X-25-5	1	Washer
*	12 518 01	1	Lead-White
*	25 518 05	1	Lead-Black

Ref. No.	Part No.	Qty.	Description
*	25 518 29	1	Lead-Black
*	24 126 71	1	Bracket - Stator Wire

\* Not illustrated

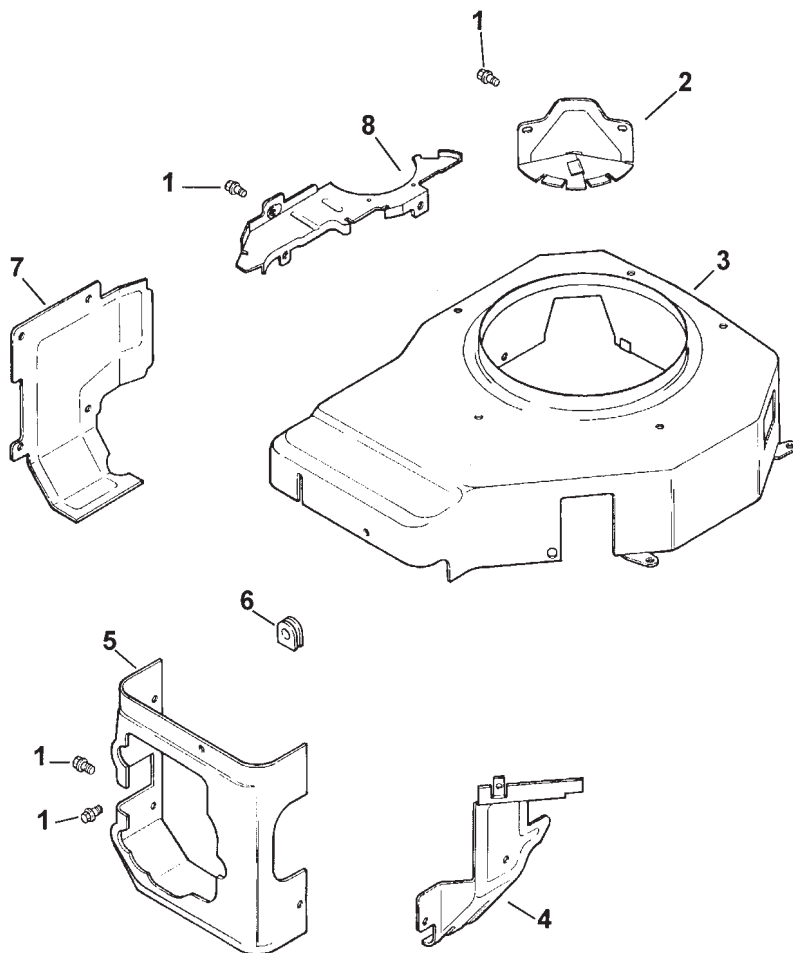

Sheet No.: 2 05

## Blower Housing And Baffles

Ref. No.	Part No.	Qty.	Description	Ref. No.	Part No.	Qty.	Description
1	M-0545010	15	Screw M5x0.8x10				
2	12 096 39	1	Cover-Starter				
3	12 027 09	1	Housing-Blower				
4	12 063 05	1	Baffle-Carburetor				
5	12 063 08	1	Baffle-Cyl. Head				
6	12 313 03	1	Grommet-Blower				
7	12 063 01	1	Baffle-Cylinder				
8	12 146 07	1	Plate-Blower Housing				
*	12 133 67	1	Decal-Horsepower				

\* Not illustrated



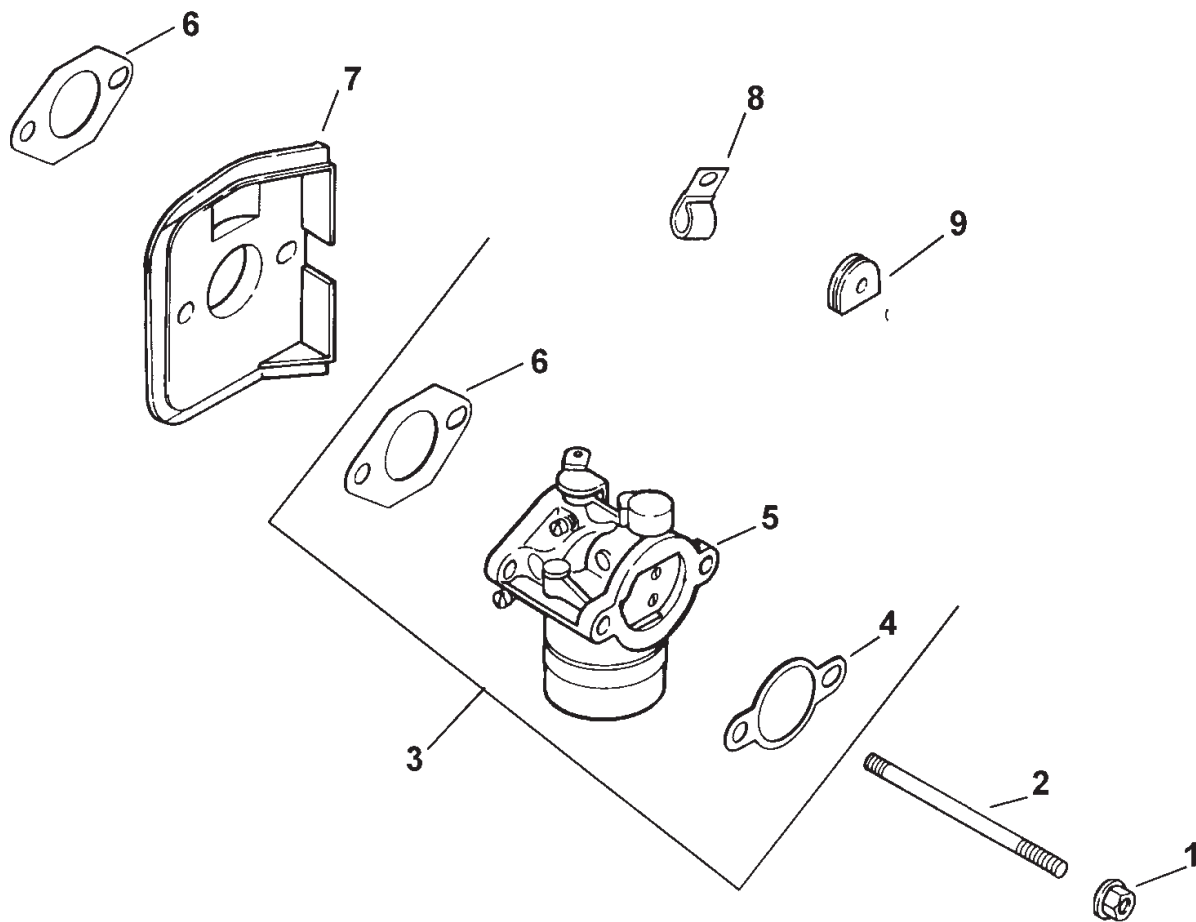

Sheet No.: 2 08

## Fuel System

Ref. No.	Part No.	Qty.	Description
1	M-0641060	2	Nut M6x1.0
2	M-0629122	2	Stud M6x1.0x110
3	12 853 80	1	Kit-Carburetor w/Gaskets
4	12 041 02	1	Gasket-Air Cleaner
5	12 053 80	1	Carburetor ASM
6	12 041 01	2	Gasket-Carburetor
7	12 265 04	1	Deflector-Heat
8	47 154 01	1	Clip-Cable
9	12 313 01	1	Grommet
*	12 757 02	1	Kit-Float
*	12 757 08	1	Kit-Choke Repair
*	12 757 03	1	Kit-Carburetor Repair

Ref. No.	Part No.	Qty.	Description

\* Not illustrated





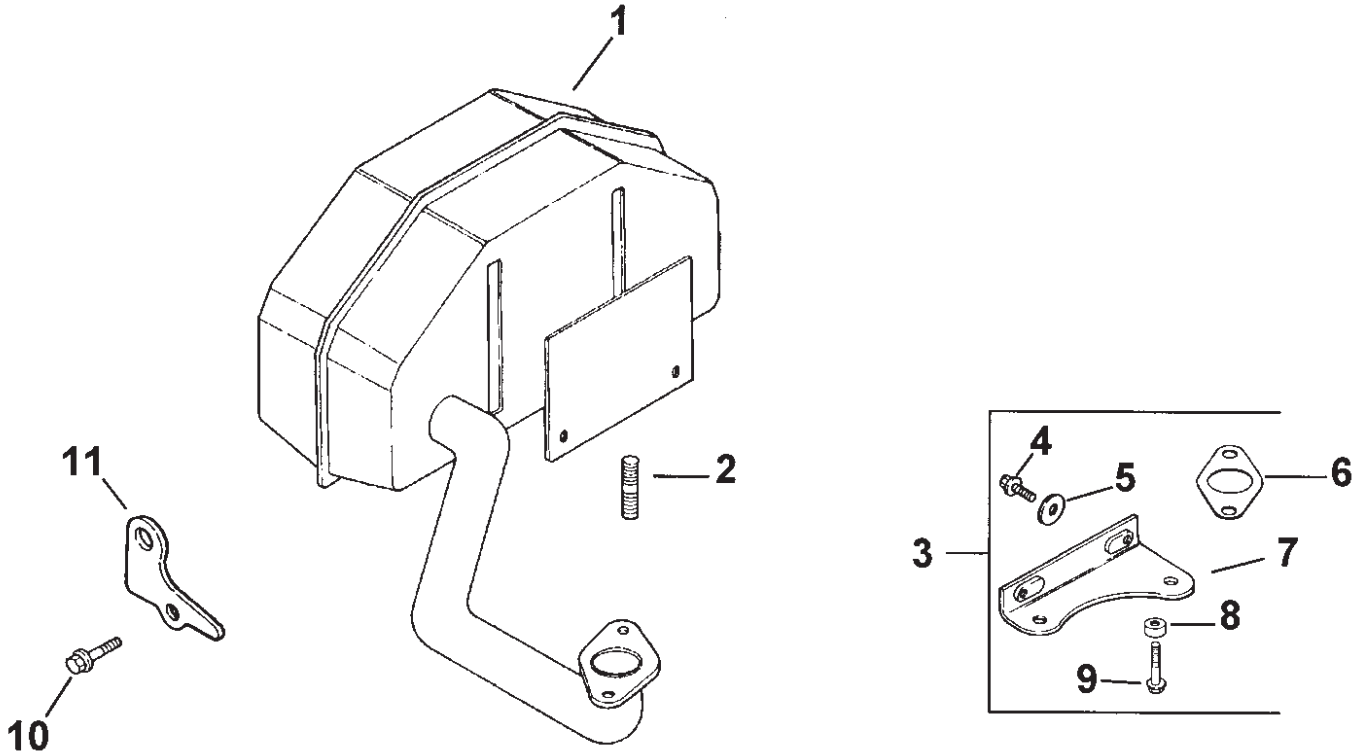

Sheet No.: 2 10

## Exhaust

Ref. No.	Part No.	Qty.	Description
1	12 068 03	1	Muffler
2	M-0829033	2	Stud M8x1.25x20
3	12 755 30	1	Kit-Bracket (Incl. Ref.#4-9)
4	M-0650012	2	Screw
5	X-25-52	2	Washer
6	12 041 03	1	Gasket - Exhaust
7	12 126 55	1	Bracket-Muffler
8	12 468 01	1	Washer
9	12 086 13	1	Screw
10	M-0645025	1	Screw
11	12 445 06	1	Strap-Lifting

Ref. No.	Part No.	Qty.	Description

\* Not illustrated

# Toro Part Number Index

Part No.	Page No.	Ref. No.	Qty.	Description
112843	5	13	1	Washer-PTO
608006	5	16	1	Key
12-5950	7	6	2	Rod-Support
23-0660	4	18	1	Switch-Starter
27-6230	5	8	1	Bolt-Wheel
29-0590	6	12	1	Screen-Filler
29-0642	1	5	1	Jiffy-Trim
44-5940	5	15	1	Pulley-Drive
47-2964	1	22	1	Hose-Gas
47-2982	5	4	1	Hose-Fuel
51-4210	7	7	2	Pad-Tank
51-4540-03	1	18	1	Retainer-Clutch
54-3094	7	3	1	ASM-Wire
54-3200	5	14	1	Clutch ASM
55-3570	5	1	1	Cap-Fuel
56-6360	1	20	1	Filter-Fuel
57-6360	5	12	1	Screw-HH
57-6380	1	17	4	Screw-HH
62-4540-03	5	10	1	Pulley-Idler
63-7590	4	10	1	Relay
63-8360	4	22	2	Key-Ignition
63-8440	1	24	1	Decal-Hot Surface
65-7410	5	27	2	Switch-Single Pole
67-8110	6	39	2	Filter-Oil
68-2190	5	7	1	Spring-Extension
68-3810	7	13	1	Tube-Vent
74-0521	3	24	1	Rod-Fitting
74-0630	4	3	1	Control-Throttle
74-0720	4	8	1	Tube-Manual
74-0761	1	23	1	Engine-Kohler
74-0930-01	1	19	1	Guard-Pulley
74-0950	1	26	2	Elbow
75-6820	4	24	1	Hour Meter
76-0200	6	11	1	ASM-Cap
77-0980	7	12	1	Boot-Terminal
77-0981	7	11	1	Boot-Terminal
80-6090	6	35	2	Key-Square
82-2181-03	4	23	1	Panel-Control
82-2190	3	11	1	Switch-Bail
82-2300	4	1	1	Switch
82-3790	5	36	2	Arm-Control
82-3820	4	2	1	Boot-Switch
82-3830	6	29	2	Hub-Wheel
82-3840	3	21	2	Spacer-Latch
82-3920	2	23	2	Stop-Reverse
82-4110	6	34	1	V Belt
82-4130	2	1	4	Bearing
82-4160	2	20	2	Spring-Detent
82-4170	6	7	1	ASM-Hose
82-4180	6	6	1	ASM-Hose
82-4192	6	15	2	ASM-Hose
82-4200	6	16	1	ASM-Hose
82-4201	6	9	1	ASM-Hose
82-4210-01	2	4	1	Bracket-Bushing
82-4220	1	30	1	Cooler-Oil
82-4240	2	21	2	Spacer-Bearing
82-4330-01	2	14	1	Arm-Detent LH
82-4340-01	2	15	1	Arm-Detent RH
82-4370	2	16	2	Bushing-Arm
82-4500-03	1	32	1	Mount-Cooler
82-4540	6	2	1	ASM-Hose
82-4550	6	1	2	ASM-Hose

\*Not Illustrated

# Toro Part Number Index (cont.)

Part No.	Page No.	Ref. No.	Qty.	Description
82-4560	6	24	1	ASM-Hose
82-4570	5	28	2	Plate-Switch
82-4580-03	5	25	2	Bracket-Neutral
82-4590	3	17	1	Decal-Slope Warning
82-4600	2	26	2	Decal-Hydro
82-4620-01	7	2	1	Strap-Battery
82-4640	7	8	1	Battery-12 Volt
82-7721	4	5	A/R	Decal-Panel
82-8230	6	22	2	Motor-Wheel
84-1830	7	14	1	Cap-Battery
86-4730-01	6	37	2	Plate-Frame
86-4740-01	6	36	2	Spacer-Frame
86-4770-03	5	6	1	Lever-Idler
86-9080	6	41	1	Head-Filter
88-1880	5	5	1	Spring-Compression
92-2350-01	7	5	2	Holder-Battery
92-9845	1	12	1	Solenoid
93-1187-03	4	16	1	Panel-Bottom
93-1189	7	10	1	Wire-Red
93-7031	1	38	1	Muffler (Supplied w/Eng)
93-7032	1	35	1	Gasket (Supplied w/Eng)
93-7033	1	37	2	Screa
93-7034	1	33	2	Nut (Supplied w/Eng)
94-9054-01	2	34	1	Arm-Pivot LH
94-9057	2	7	1	Lever-Pivot LH
94-9059	2	5	1	Lever-Pivot RH
94-9061-01	2	35	1	Arm-Pivot RH
94-9062	2	11	2	Sleeve
94-9093	2	9	2	Rod-Link
94-9095	3	15	1	Rod-Control
94-9096-01	2	37	1	Frame ASM
94-9664	6	26	2	ASM-Wheel & Tire
94-9666	4	17	1	Module
95-1504	3	4	1	Turnbuckle
95-1505	3	5	1	Rod-Control
95-1506	3	1	1	Rod-Control
95-1507-03	3	9	1	Control Bar ASM
95-1510-03	3	10	1	Bail ASM
95-1513-03	3	16	1	Pivot ASM
95-1516	2	30	2	Spacer-Tubular
95-1522-01	2	39	1	Bracket-Pivot
95-1523	3	12	1	Decal-Traction Drive
95-1524	3	13	1	Decal-T Bar
95-1526	5	21	1	Trailing Shield
95-1528	6	33	2	Pulley-Pump
95-1529	5	20	1	Rod-Shield
95-1530-01	2	29	1	Bracket-Pivot
95-1532	6	13	1	Reservoir-Oil
95-1536	3	7	1	Handle ASM
95-1538	5	32	2	Hydraulic Pump ASM
95-1543	5	37	1	Decal-Valve Adjust
95-1544	4	4	1	Decal-Warning
95-2802	5	2	1	Tank-Fuel
95-2807	3	27	1	Harness-Wire
95-2814	1	1	1	Decal-Fuel Shut-Off
95-5853	3	22	2	Lock ASM-Quick Release
95-5854	3	33	2	Sleeve
95-5855-03	3	18	2	Spacer-Pivot
95-5856-03	3	29	1	Handle-Upper
95-5859	4	5	1	Decal-Control Panel
95-5862	3	34	1	Decal-Speed Lock
95-5868-01	2	40	1	Guard-Filter

\*Not Illustrated

# Toro Part Number Index (cont.)

Part No.	Page No.	Ref. No.	Qty.	Description
218-461	4	21	1	Nut-HH (F/W Sw)
218-595	3	30	1	Connector-Body
231-117	6	26:3	2	Tire-15x6
232-27	6	26:1	2	Valve Stem & Cap Assembly
237-30	6	3:1	4	O-Ring
237-79	6	3:2	4	O-Ring
237-124	5	34	1	Grommet
240-9	1	6	2	Grommet
242-50	6	27	8	Nut-Lug
242-87	6	26:2	2	Wheel
2410-71	1	4	2	Cap-Plug
2412-98	1	21	2	Clamp-Hose
2412-98	5	3	2	Clamp-Hose
2412-106	1	9	1	R Clamp
2412-106	1	14	1	R Clamp
2412-120	4	9	2	Clamp-R
2412-134	1	31	2	Clamp R
2412-136	1	7	2	Clamp
251-259	2	22	2	Bearing-Ball
257-5	2	36	2	Washer-Thrust
283-6	3	25	1	Pin-Clevis
283-55	3	20	2	Pin-Clevis
288-4	1	25	1	Cap-Pipe
289-51	1	27	1	Nipple-Pipe
2815-15	6	10	1	Fitting-Hydraulic
2815-16	6	5	1	Fitting-Hydraulic
321-3	2	25	11	Screw-HH
321-3	4	14	1	Screw-HH
321-3	6	43	2	Screw-HH
321-8	2	31	2	Screw-HH
321-39	1	3	6	Screw-HH
322-3	5	18	4	Screw-HH
322-3	6	18	3	Screw-HH
322-3	7	9	2	Screw-HH
322-5	2	2	2	Screw-HH
322-7	2	18	2	Screw-HH
322-7	5	35	2	Screw-HH
322-14	2	24	2	Screw-HH
323-6	2	27	6	Screw-HH
323-9	5	11	1	Screw-HH
323-9	7	15	2	Screw-HH
324-5	5	22	4	Screw-HH
325-11	6	31	8	Screw-HH
3213-8	6	30	8	Screw-HH
3218-2	2	10	4	Nut-Hex Jam
3234-11	3	26	4	Screw-HHF
3234-32	7	18	6	Screw-HH
3241-5	6	32	4	Set Screw
3253-3	6	42	2	Washer-Lock
3253-4	1	16	4	Washer-Lock
3253-4	1	34	2	Washer-Lock
3253-4	5	19	4	Washer-Lock
3253-4	6	17	3	Washer-Lock
3254-5	4	19	1	Washer-Lock
3255-7	4	13	A/R	Washer-Lock
3256-1	1	2	6	Washer-Flat
3256-1	5	24	4	Washer-Flat
3256-23	1	15	4	Washer-Flat
3256-23	2	17	2	Washer-Flat
3256-23	3	23	1	Washer-Flat
3256-78	1	36	2	Washer-Plain
3257-8	6	25	2	Key-Woodruff

\*Not Illustrated

# Toro Part Number Index (cont.)

Part No.	Page No.	Ref. No.	Qty.	Description
3269-8	5	38	2	Rivet
3274-32	2	19	2	Screw-HH
3290-307	3	2	4	Pin-Cotter
3290-378	2	3	1	Tie-Cable
3290-378	3	8	3	Tie-Cable
3290-378	5	26	2	Tie-Cable
3290-392	4	15	A/R	Screw-HH
3290-436	3	32	2	Washer-Belleville
3296-2	3	6	1	Nut Lock
3296-2	4	6	4	Nut Lock
3296-6	5	17	1	Nut-Lock
3296-23	6	38	8	Nut-Lock
3296-29	2	6	6	Nut-Lock
3296-29	5	30	2	Nut-Lock
3296-39	2	38	6	Nut-Lock
3296-39	5	9	1	Nut-Lock
3296-39	7	16	2	Nut-Lock
3296-42	1	29	2	Nut-Lock
3296-42	2	32	11	Nut-Lock
3296-42	4	12	1	Nut-Lock
3296-42	7	1	2	Nut-Lock
3296-47	2	13	2	Nut-Lock
3296-54	4	11	A/R	Nut
32103-3	3	3	1	Nut-Wing
32104-76	1	8	1	Screw-Self TAP
32104-76	4	20	4	Screw-Self TAP
32105-12	3	14	1	Screw-Hex
32105-14	4	7	4	Screw-HH
32112-17	6	28	8	Pushnut
32121-4	2	33	2	Pin-Roll
32128-10	2	28	2	Nut-Lock HHF
32128-21	3	28	4	Nut-Hfh
32128-23	7	17	6	Nut-Lock
32128-42	5	33	4	Nut-Hex Flange
32144-1	5	29	4	Screw-HH
32144-3	5	23	4	Screw-HWH
32144-4	1	13	3	Screw-TAP
32144-18	4	25	2	Screw-HWH
32149-1	7	4	2	Nut-Keps
32149-2	1	11	2	Nut-Hex Lock
32151-3	2	8	4	Ring-Retaining
32151-80	3	19	2	Ring-Push On
33023-00	3	31	2	Nut-Lock Ni
340-4	6	3	4	Ftg-Hyd
340-6	6	23	4	Fitting-Ors
354-115	6	8	2	Ftg-Hyd
354-116	6	4	2	Fitting-Hydraulic
354-117	6	40	2	Fitting-Hydraulic
354-118	6	14	2	Fitting-Hydraulic

\*Not Illustrated



