



ProStripe 560 Mower

Model No. 02656—Serial No. 313000001 and Up

Operator's Manual

Introduction

Read this information carefully to learn how to operate and maintain your product properly and to avoid injury and product damage. You are responsible for operating the product properly and safely.

You may contact Toro directly at www.Toro.com for product and accessory information, help finding a dealer, or to register your product.

Whenever you need service, genuine Toro parts, or additional information, contact an Authorized Service Dealer or Toro Customer Service and have the model and serial numbers of your product ready. **Figure 1** identifies the location of the model and serial numbers on the product.

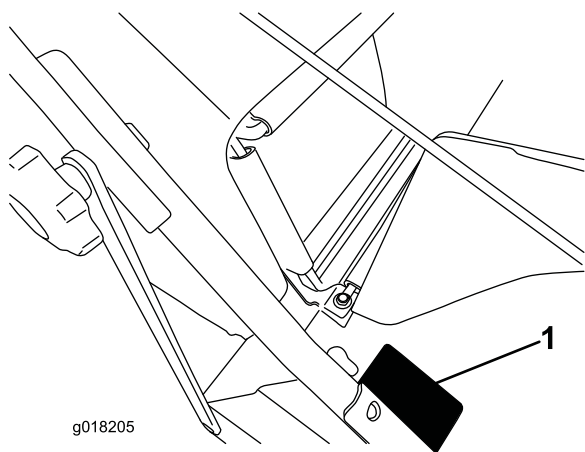

Figure 1

1. Model and serial number plate

Write the product model and serial numbers in the space below:

<p>Model No. _____</p> <p>Serial No. _____</p>
--

This manual identifies potential hazards and has safety messages identified by the safety alert symbol (**Figure 2**), which signals a hazard that may cause serious injury or death if you do not follow the recommended precautions.



Figure 2

1. Safety alert symbol

This manual uses 2 words to highlight information.

Important calls attention to special mechanical information and **Note** emphasizes general information worthy of special attention.

For models with stated engine horsepower, the gross horsepower of the engine was laboratory rated by the engine manufacturer in accordance with SAE J1940. As configured to meet safety, emission, and operating requirements, the actual engine horsepower on this class of lawn mower will be significantly lower.

Contents

- Introduction 1
- Safety 2
 - General Lawn Mower Safety 2
 - Sound Pressure 3
 - Sound Power 3
 - Hand-Arm Vibration 3
 - Safety and Instructional Decals 4
- Setup 6
 - 1 Unfolding the Handle 6
 - 2 Assembling the Grass Bag 6
 - 3 Filling the Engine with Oil 7
- Product Overview 8
 - Specifications 8
- Operation 9
 - Filling the Fuel Tank 9
 - Checking the Engine Oil Level 10
 - Adjusting the Cutting Height 10
 - Starting the Engine 11
 - Using the Self-propel Drive 11
 - Stopping the Engine 12
 - Bagging the Clippings 12
 - Operating Tips 12
- Maintenance 13
 - Recommended Maintenance Schedule(s) 13
 - Preparing for Maintenance 13
 - Replacing the Air Filter 13
 - Changing the Engine Oil 14
 - Adjusting the Self-propel Cable 15
 - Replacing the Blade 16



Sharpening the Blade	16
Cleaning the Machine.....	17
Storage	18
Preparing the Machine for Storage	18
Folding the Handle	19
Removing the Machine from Storage.....	19

Safety

Improperly using or maintaining this machine can result in injury. To reduce the potential for injury, comply with these safety instructions.

Toro designed and tested this machine for reasonably safe service; however, failure to comply with the following instructions may result in personal injury.

To ensure maximum safety, best performance, and to gain knowledge of the product, it is essential that you and any other operator of the machine read and understand the contents of this manual before the engine is ever started. Pay particular attention to the safety alert symbol (Figure 2) which means Caution, Warning, or Danger—“personal safety instruction.” Read and understand the instruction because it has to do with safety. Failure to comply with the instruction may result in personal injury.

General Lawn Mower Safety

The following instructions have been adapted from the ISO standard 5395.

This cutting machine is capable of amputating hands and feet and throwing objects. Failure to observe the following safety instructions could result in serious injury or death.

Training

- Read the *Operator’s Manual* and other training material. If the operator(s) or mechanic(s) cannot read English, it is the owner’s responsibility to explain this material to them.
- Become familiar with the safe operation of the equipment, operator controls, and safety signs.
- All operators and mechanics should be trained. The owner is responsible for training the users.
- Never allow children or people unfamiliar with these instructions to use the mower. Local regulations can restrict the age of the operator.
- Keep in mind that the operator or user is responsible for accidents or hazards occurring to other people or their property.
- Understand explanations for all pictograms used on the mower or in the instructions.

Gasoline

WARNING-Gasoline is highly flammable. Take the following precautions.

- Store fuel in containers specifically designed for this purpose.
- Refuel outdoors only and do not smoke while refueling.
- Add fuel before starting the engine. Never remove the cap of the fuel tank or add gasoline while the engine is running or when the engine is hot.
- If gasoline is spilled, do not attempt to start the engine but move the mower away from the area of spillage and avoid creating any source of ignition until gasoline vapors have dissipated.
- Replace all fuel tank and container caps securely.

Preparation

- While mowing, always wear substantial footwear, long trousers, and ear protection. Do not operate the equipment when barefoot or wearing open sandals. Long hair, loose clothing, or jewelry may get tangled in moving parts.
- Thoroughly inspect the area where the equipment is to be used and remove all stones, sticks, wires, bones and other foreign objects which can be thrown by the machine.
- Before using, always visually inspect to see that guards, and safety devices, such as deflectors and/or grass catchers, are in place and working correctly.
- Before using, always visually inspect to see that the blades, blade bolts and cutter assembly are not worn or damaged. Replace worn or damaged blades and bolts in sets to preserve balance.

Starting

Do not tilt the mower when starting the engine.

Operation

- Never mow while people, especially children, or pets are nearby.
- Mow only in daylight or in good artificial light.
- Avoid operating the equipment in wet grass, where feasible.
- Stay alert for holes in the terrain and other hidden hazards.
- Do not put hands or feet near or under rotating parts. Keep clear of the discharge opening at all times.
- Never operate with the discharge deflector raised, removed or altered, unless using a grass catcher.
- Never pick up or carry a lawn mower while the engine is running.
- Use extreme caution when reversing or pulling a pedestrian controlled lawn mower towards you.
- Walk, never run.
- Slopes:

- Do not mow excessively steep slopes.
- Exercise extreme caution when on slopes.
- Mow across the face of slopes, never up and down and exercise extreme caution when changing direction on slopes.
- Always be sure of your footing on slopes.
- Reduce speed on slopes and in sharp turns to prevent overturning or loss of control.
- Stop the blade if the lawn mower has to be tilted for transportation when crossing surfaces other than grass and when transporting the lawn mower to and from the area to be mowed.
- Do not operate the engine in a confined space where dangerous carbon monoxide fumes can collect.
- Park on level ground.
- Stop the engine
 - whenever you leave the lawn mower.
 - before refueling.
 - before removing the grass catcher.
 - before making height adjustment unless adjustment can be made from the operator's position.
- Stop the engine and disconnect the spark plug wire.
 - before clearing blockages or unclogging chute.
 - before checking, cleaning or working on the lawn mower.
 - after striking a foreign object, inspect the lawn mower for damage and make repairs before restarting and operating the lawn mower.
 - if lawn mower starts to vibrate abnormally (check immediately).
- Lightning can cause severe injury or death. If you see lightning or hear thunder in the area, do not operate the machine; seek shelter.
- Watch out for traffic when crossing or near roadways.
- Be aware of the mower discharge direction and do not point it at anyone.
- Do not operate the mower under the influence of alcohol or drugs.
- Use care when loading or unloading the machine into a trailer or truck.
- Use care when approaching blind corners, shrubs, trees, or other objects that may obscure vision.
- Keep all nuts, bolts and screws tight to be sure the equipment is in safe working condition. Replace all worn or damaged labels.
- Do not use pressure cleaning equipment on machine.
- Never store the equipment with gasoline in the tank and inside a building where fumes can reach an open flame or spark.
- Allow the engine to cool before storing in any enclosure.
- To reduce the fire hazard, keep the engine, silencer, and gasoline storage area free of grass, leaves, or excessive grease.
- Clean up any oil or fuel spill.
- Check grass catcher components and the discharge guard frequently and replace with manufacturer's recommended parts, when necessary.
- Replace worn or damaged parts for safety.
- Replace faulty silencers.
- If the fuel tank has to be drained, do this outdoors.
- Do not change the engine governor settings or overspeed the engine. Operating an engine at excessive speed can increase the hazard of personal injury.
- Be careful during adjustment of the lawn mower to prevent entrapment of the fingers between moving blades and fixed parts of the lawn mower.
- Use care when checking blades. Wrap the blade(s) or wear gloves, and use caution when servicing them. Only replace blades. Never straighten or weld them.
- **To ensure the best performance and safety, purchase only genuine Toro replacement parts and accessories. Do not use *will fit* parts and accessories; they may cause a safety hazard.**

Sound Pressure

This unit has a sound pressure level at the operator's ear of 89 dBA, which includes an Uncertainty Value (K) of 2 dBA. The sound pressure level was determined according to the procedures outlined in EN 836.

Sound Power

This unit has a guaranteed sound power level of 98 dBA, which includes an Uncertainty Value (K) of 1 dBA. The sound power level was determined according to the procedures outlined in ISO 11094.

Hand-Arm Vibration

Measured vibration level for the left hand = 2.8 m/s²

Measured vibration level for the right hand = 3.2 m/s²

Uncertainty Value (K) = 1.6 m/s²

The measured values were determined according to the procedures outlined in EN 836.

Maintenance and Storage

- Disengage drives, lower implement, set parking brake, stop engine, and remove key or disconnect spark plug wire. Wait for all movement to stop before adjusting, cleaning, or repairing.
- Park machine on level ground. Never allow untrained personnel to service machine.
- Keep hands and feet away from moving parts. If possible, do not make adjustments with the engine running.

Safety and Instructional Decals

Important: Safety and instruction decals are located near areas of potential danger. Replace damaged decals.

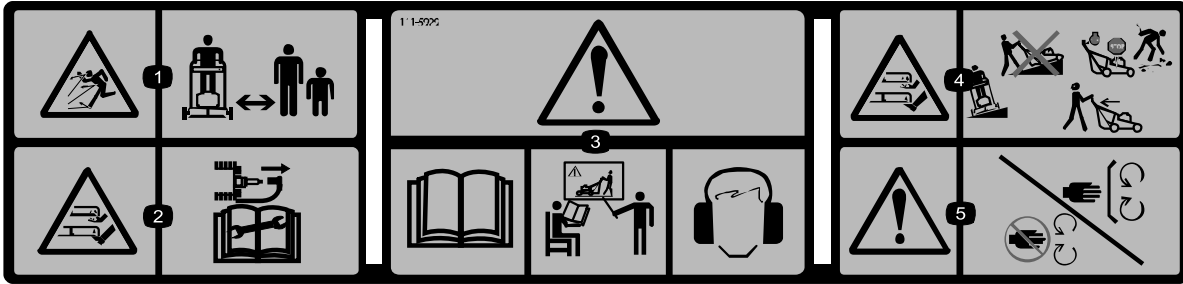

111-5929

1. Thrown object hazard—keep bystanders a safe distance from the machine.
2. Cutting/dismemberment hazard of hand or foot, mower blade—disconnect the spark plug and read the *Operator's Manual* before servicing or performing maintenance.
3. Warning—read the *Operator's Manual*; do not operate this machine unless you are trained; wear ear protection.
4. Cutting/dismemberment hazard of hand or foot, mower blade—operate side to side on slopes; do not operate up and down slopes; stop the engine and pick up any debris; look behind you when moving the machine backwards.
5. Warning—keep away from moving parts; keep all guards in place.



94-8072

1. Warning—cutting/dismemberment hazard of hand or foot, cutting mechanism.

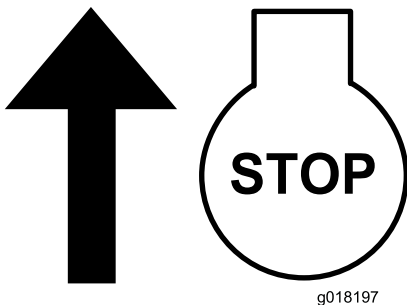

340179

1. Blade Control Bar



111-6866

1. Blade height adjustment



g018199

111-3444
Engine-Speed Controller

Setup

Important: Remove and discard the protective plastic sheet that covers the engine.

1

Unfolding the Handle

No Parts Required

Procedure

⚠ WARNING

Assembling and unfolding the handle improperly can damage the cables, causing an unsafe operating condition.

- Do not damage the cables when assembling and unfolding the handle.
- If a cable is damaged, contact an Authorized Service Dealer.

1. Loosen the handlebar knobs (Figure 3).

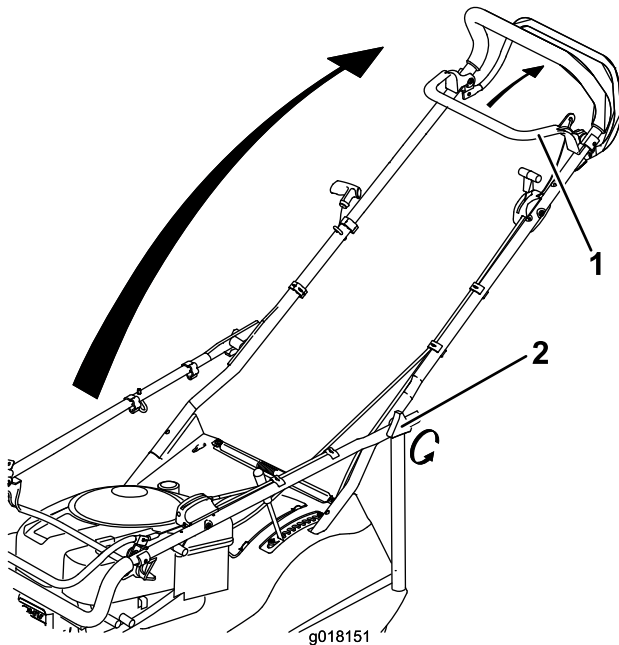

Figure 3

1. Blade control bar
2. Handlebar knobs

2

Assembling the Grass Bag

No Parts Required

Procedure

1. Insert the frame into the grass bag, keeping the handle above the grass bag (Figure 4).

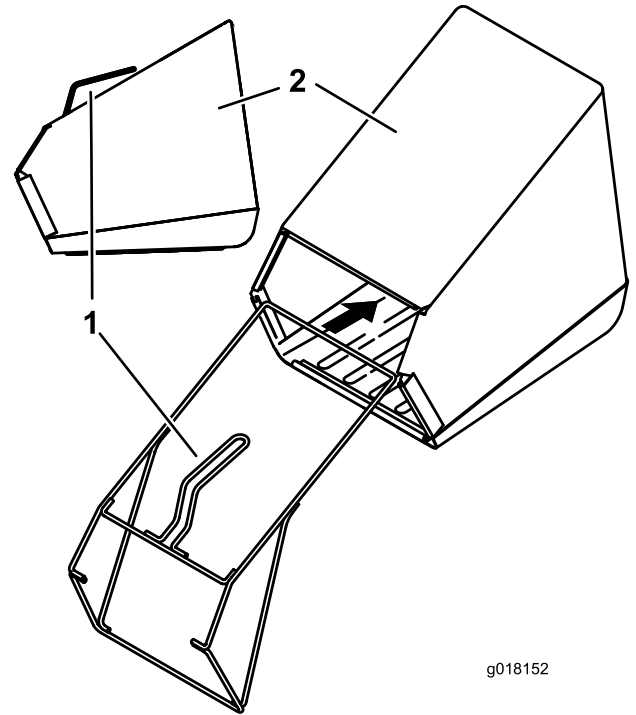

Figure 4

1. Frame
2. Grass bag

2. Hold the blade-control bar against the handlebar, unfold the handlebar to the proper operating position, then release the blade-control bar.
3. Tighten the handlebar knobs.

2. Attach the plastic clips to the grass-bag frame ([Figure 5](#)).

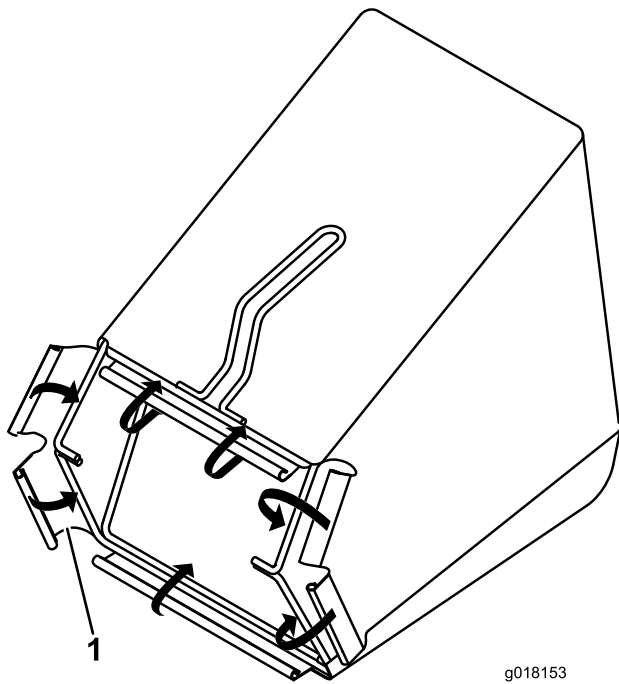

Figure 5

1. Plastic clips

3

Filling the Engine with Oil

No Parts Required

Procedure

Your machine does not come with oil in the engine. Before starting the engine, fill the engine with oil.

Max. fill: 20 oz. (0.59 l), type: SAE 30 detergent oil with an API service classification of SF, SG, SH, SJ, SL, or higher.

1. Remove the dipstick ([Figure 6](#)).

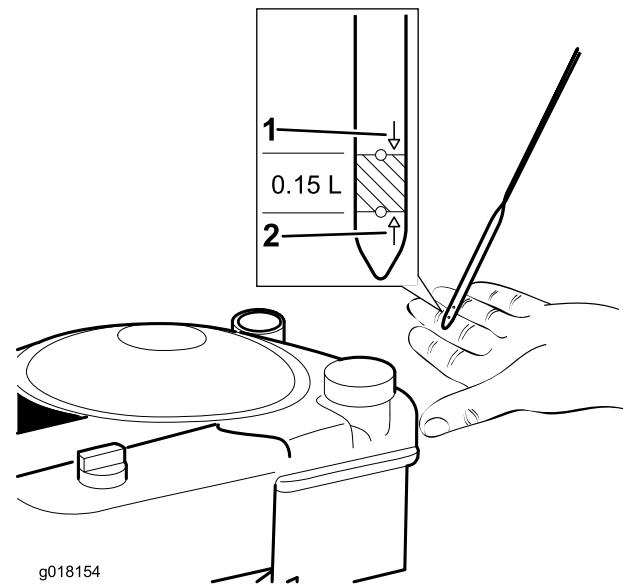

Figure 6

1. Full
2. Add

2. **Slowly** pour oil into the oil-fill tube, wait 3 minutes, and check the oil level on the dipstick by wiping the dipstick clean and then fully inserting the dipstick into the tube ([Figure 6](#)).
3. Fill the engine with oil until the engine oil level is correct on the dipstick, as shown in [Figure 6](#).

Note: If you overfill the engine with oil, remove the excess oil as directed in [Changing the Engine Oil \(page 14\)](#).

4. Install the dipstick and tighten it securely.

Important: *Change the engine oil after the first 5 operating hours; change it yearly thereafter; refer to [Changing the Engine Oil \(page 14\)](#).*

Product Overview

Specifications

Model	Weight	Length	Width	Height
02656	51 kg (112 lb)	156.5 cm (61.6 in)	58.5 cm (23 in)	108 cm (42.5 in)

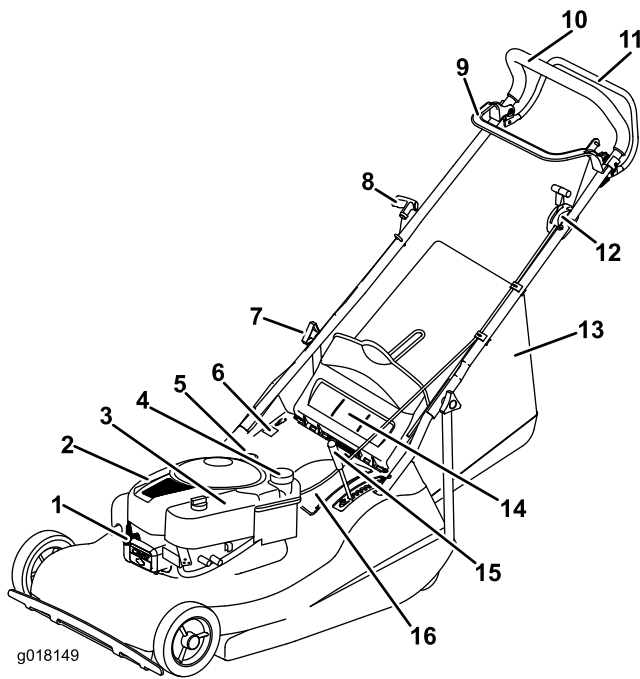

Figure 7

- | | |
|----------------------------|-----------------------------|
| 1. Spark-plug wire | 9. Blade-control bar |
| 2. Engine cover | 10. Handlebar |
| 3. Air cleaner | 11. Self-propel-drive bar |
| 4. Fuel-filler cap | 12. Engine-speed controller |
| 5. Oil-filler cap/dipstick | 13. Grass-bag assembly |
| 6. Serial number label | 14. Rear deflector |
| 7. Handlebar knob | 15. Height-of-cut adjuster |
| 8. Recoil-start handle | 16. Battery cover |

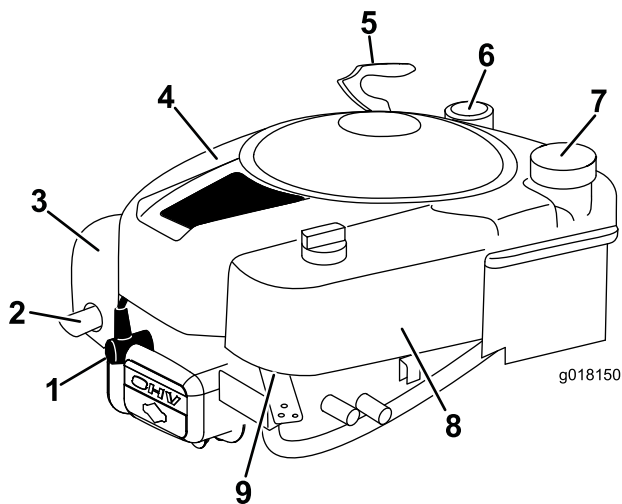

Figure 8

- | | |
|------------------------|----------------|
| 1. Spark-plug wire | 6. Dipstick |
| 2. Exhaust | 7. Fuel cap |
| 3. Exhaust guard | 8. Air cleaner |
| 4. Cover | 9. Carburetor |
| 5. Recoil-start handle | |

Operation

Filling the Fuel Tank

▲ DANGER

Gasoline is extremely flammable and explosive. A fire or explosion from gasoline can burn you and others.

- To prevent a static charge from igniting the gasoline, place the container and/or machine directly on the ground before filling, not in a vehicle or on an object.
- Fill the tank outdoors when the engine is cold. Wipe up spills.
- Do not handle gasoline when smoking or around an open flame or sparks.
- Store gasoline in an approved fuel container, out of the reach of children.
- For best results, use only clean, fresh, unleaded gasoline with an octane rating of 87 or higher ((R+M)/2 rating method).
- Oxygenated fuel with up to 10% ethanol or 15% MTBE by volume is acceptable.
- *Do not* use ethanol blends of gasoline (such as E15 or E85) with more than 10% ethanol by volume. Performance problems and/or engine damage may result which may not be covered under warranty.
- *Do not* use gasoline containing methanol.
- *Do not* store fuel either in the fuel tank or fuel containers over the winter unless a fuel stabilizer is used.
- *Do not* add oil to gasoline.

Fill the fuel tank with fresh unleaded regular gasoline from a major name-brand service station. Refer to [Filling the Fuel Tank \(page 9\)](#).

Important: To reduce starting problems, add fuel stabilizer to the fuel all season, mixing it with gasoline less than 30 days old.



g018155

Figure 9

Checking the Engine Oil Level

Service Interval: Before each use or daily

1. Remove the dipstick and wipe it with a clean cloth.
2. Fully insert the dipstick.
3. If the oil level is low, **slowly** pour oil into the oil-fill tube, wait 3 minutes, and check the oil level on the dipstick by wiping the dipstick clean and then inserting the dipstick into the tube (Figure 10).

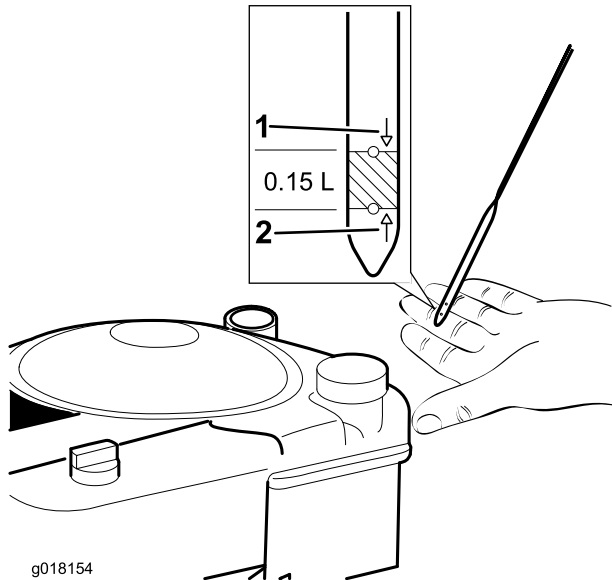

Figure 10

1. Full
2. Add

4. Fill the engine with oil until the dipstick indicates that the engine oil level is correct as shown in Figure 10. If you overfill the engine with oil, remove the excess oil as directed in [Checking the Engine Oil Level \(page 10\)](#).
5. Install the dipstick and tighten it securely.

Important: *Change the engine oil after the first 5 operating hours; change it yearly thereafter. Refer to [Changing the Engine Oil \(page 14\)](#).*

Adjusting the Cutting Height

⚠ WARNING

Adjusting the cutting height may bring you into contact with the moving blade, causing serious injury.

- Stop the engine and wait for all moving parts to stop.
- Do not put your fingers under the housing when adjusting the cutting height.

⚠ CAUTION

If the engine has been running, the muffler will be hot and can severely burn you.

Keep away from the hot muffler.

1. Grip the lever and pull sideways to disengage it from the locking notch (Figure 11).

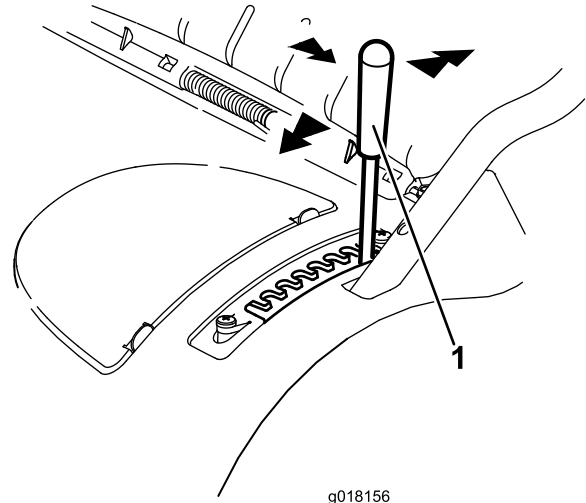

Figure 11

1. Height-of-cut adjusting lever

2. Push it forwards to lower or pull it backwards to raise the height of cut (Figure 11).
3. Release the lever at the required position and ensure that it locks firmly into 1 of the 8 setting notches (Figure 11).

Starting the Engine

1. Hold the blade-control bar against the handlebar (Figure 12).

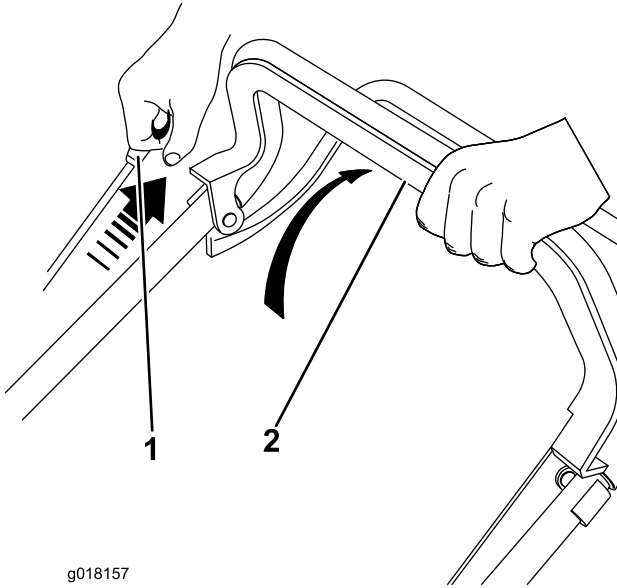

Figure 12

1. Recoil-start handle
2. Blade-control bar

2. Pull the recoil-start handle (Figure 12).

Important: To prevent damage to the machine, never pull the recoil start handle when the engine is running.

Note: If the machine does not start, contact an Authorized Service Dealer.

Using the Self-propel Drive

To operate the self-propel drive, squeeze the self-propel drive bar toward the handle and hold it in place (Figure 13).

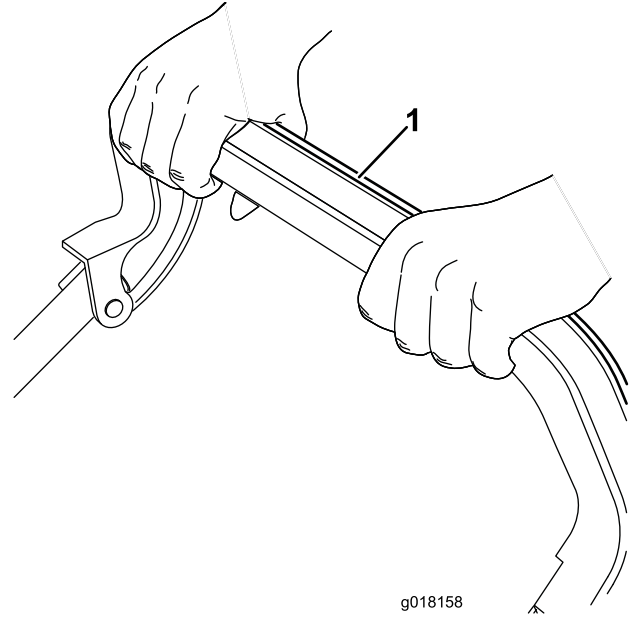

Figure 13

1. Self-propel-drive bar

To disengage the self-propel drive, release the self-propel-drive bar.

Stopping the Engine

Release the blade-control bar.

Important: When you release the blade control bar, the blade should stop within 3 seconds. If it does not stop properly, stop using your machine immediately and contact an Authorized Service Dealer.

Bagging the Clippings

Install the grass bag to collect grass and leaf clippings from the lawn.

⚠ WARNING

A worn grass bag could allow debris to be thrown and result in serious personal injury or death to the operator or bystanders.

Check the grass bag frequently. If it is damaged, install a new Toro replacement bag.

⚠ WARNING

The blade is sharp; contacting the blade can result in serious personal injury.

Stop the engine and wait for all moving parts to stop before leaving the operating position.

1. Stop the engine and wait for all moving parts to stop.
2. Raise and hold up the rear deflector.
3. Hook the grass bag into position (Figure 14).

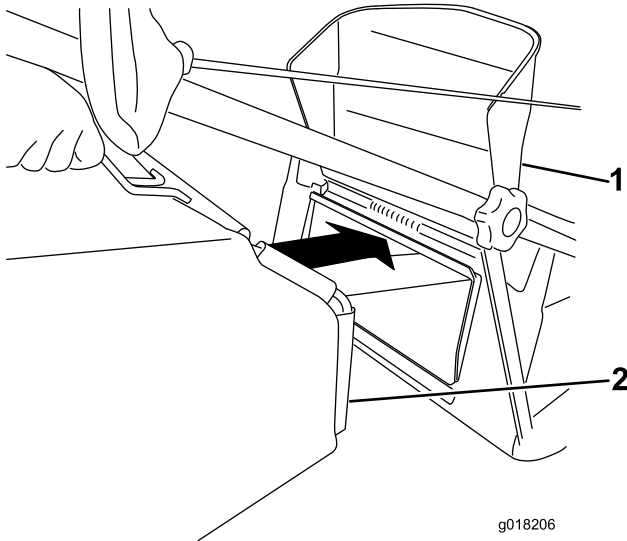

Figure 14

1. Rear deflector
2. Grass bag

4. Lower the rear deflector.

Operating Tips

General Mowing Tips

- Clear the area of sticks, stones, wire, branches, and other debris that the blade could hit.
- Avoid striking solid objects with the blade. Never deliberately mow over any object.
- If the machine strikes an object or starts to vibrate, immediately stop the engine, disconnect the wire from the spark plug, and examine the machine for damage.
- For best performance, install a new blade before the cutting season begins.
- Replace the blade when necessary with a Toro replacement blade.

Cutting Grass

- Cut only about a third of the grass blade at a time. Do not cut below the 51 mm (2-inch) setting unless the grass is sparse or it is late fall when grass growth begins to slow down. Refer to Adjusting the Cutting Height.
- When cutting grass over 15 cm (6 inches) tall, mow at the highest cutting height setting and walk slower; then mow again at a lower setting for the best lawn appearance. If the grass is too long, the machine may plug and cause the engine to stall.
- Mow only dry grass or leaves. Wet grass and leaves tend to clump on the yard and can cause the machine to plug or the engine to stall.

⚠ WARNING

Wet grass or leaves can cause serious injury if you slip and contact the blade. Mow only in dry conditions.

- Alternate the mowing direction. This helps disperse the clippings over the lawn for even fertilization.
- If the finished lawn appearance is unsatisfactory, try one or more of the following:
 - Replace the blade or have it sharpened.
 - Walk at a slower pace while mowing.
 - Raise the cutting height on your machine.
 - Cut the grass more frequently.
 - Overlap cutting swaths instead of cutting a full swath with each pass.

Cutting Leaves

After cutting the lawn, ensure that half of the lawn shows through the cut leaf cover. You may need to make more than one pass over the leaves.

Maintenance

Note: Determine the left and right sides of the machine from the normal operating position.

Recommended Maintenance Schedule(s)

Maintenance Service Interval	Maintenance Procedure
After the first 5 hours	<ul style="list-style-type: none">• Change the engine oil.
Before each use or daily	<ul style="list-style-type: none">• Check the engine oil level.• Ensure that the engine stops within 3 seconds after releasing the blade control bar.• Clean grass clippings and dirt from under the machine.
Every 25 hours	<ul style="list-style-type: none">• Replace the air filter.• Check the self-propel cable and adjust if needed.• Replace the blade or have it sharpened (more frequently if the edge dulls quickly).• Sharpen the blade.
Every 50 hours	<ul style="list-style-type: none">• Change the engine oil.
Before storage	<ul style="list-style-type: none">• Empty the fuel tank before repairs as directed and before annual storage.
Yearly	<ul style="list-style-type: none">• Refer to your engine operator's manual for any additional yearly maintenance procedures.

Important: Refer to your *engine operator's manual* for additional maintenance procedures.

Preparing for Maintenance

1. Stop the engine and wait for all moving parts to stop.
2. Disconnect the spark-plug wire from the spark plug (Figure 15) before performing any maintenance procedure.

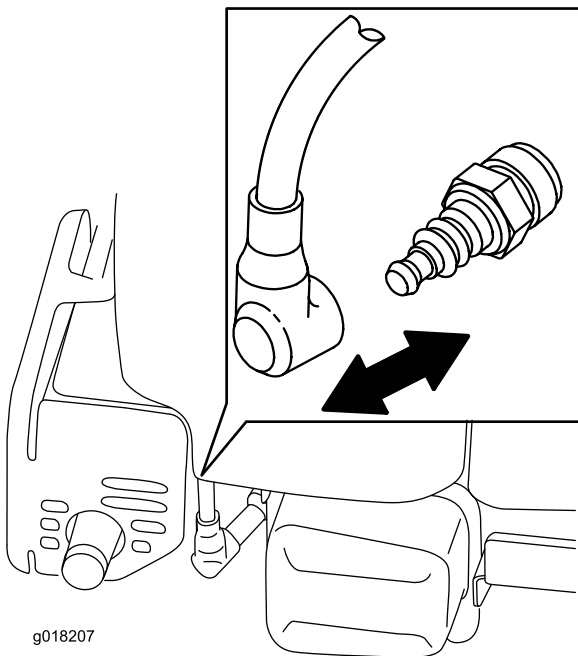

Figure 15

Important: Before tipping the machine to change the oil or replace the blade, allow the fuel tank to run dry through normal usage. If you must tip the machine prior to running out of fuel, use a hand fuel pump to remove the fuel. Always tip the machine onto its side with the air filter up.

⚠ WARNING

Tipping the machine may cause the fuel to leak. Gasoline is flammable, explosive, and can cause personal injury.

Run the engine dry or remove the gasoline with a hand pump; never siphon.

Replacing the Air Filter

Service Interval: Every 25 hours

1. Perform the pre-maintenance procedures; refer to [Preparing for Maintenance \(page 13\)](#).
2. Loosen the knob securing the air-filter cover (Figure 16).

3. After performing the maintenance procedure(s), connect the spark-plug wire to the spark plug.

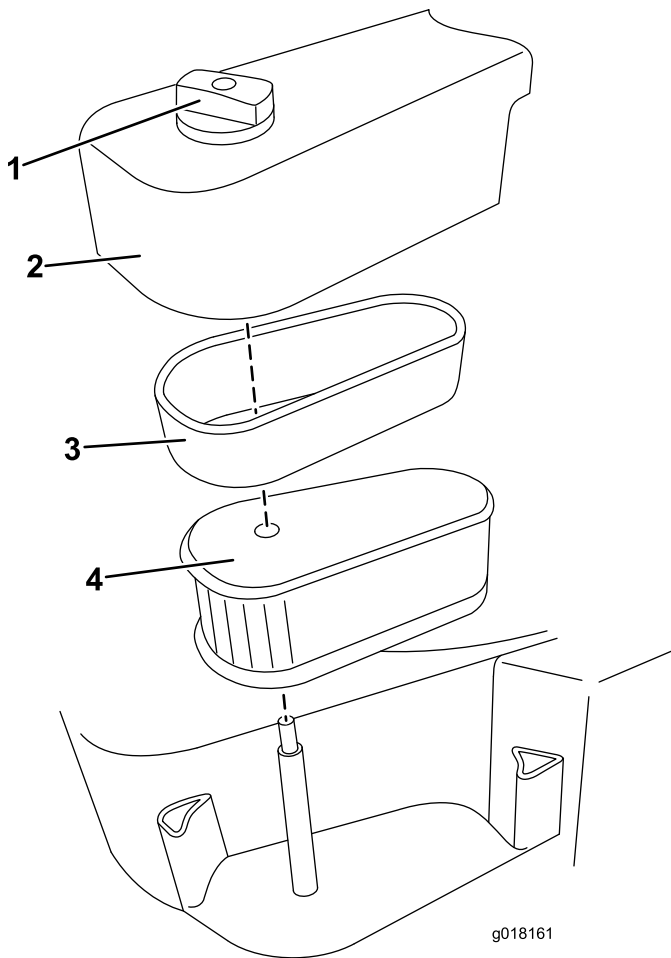

Figure 16

- | | |
|---------------------|----------------|
| 1. Knob | 3. Cartridge |
| 2. Air-filter cover | 4. Foam filter |

3. Remove the cover.
4. Carefully remove the foam filter and the cartridge together, then separate the foam filter from the cartridge (Figure 16).
5. If the filter is extremely dirty, replace it.
6. Place the filter back into the cartridge, then place both into the air filter.
7. Install the cover (Figure 16).

Changing the Engine Oil

Service Interval: After the first 5 hours

Every 50 hours

Run the engine a few minutes before changing the oil to warm it. Warm oil flows better and carries more contaminants.

1. Perform the pre-maintenance procedures; refer to [Preparing for Maintenance \(page 13\)](#).
2. Remove the dipstick and wipe it with a clean cloth (Figure 17).

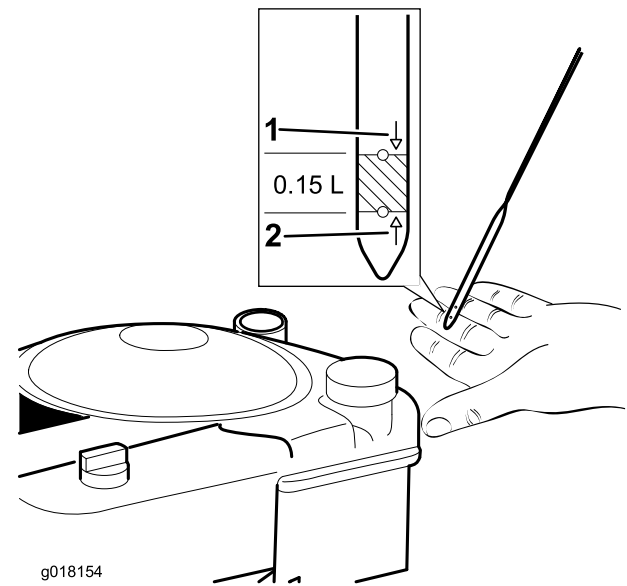

Figure 17

1. Full
2. Add

3. Tip the machine onto its side, with the air filter up, to drain the used oil out through the oil-fill tube (Figure 18).

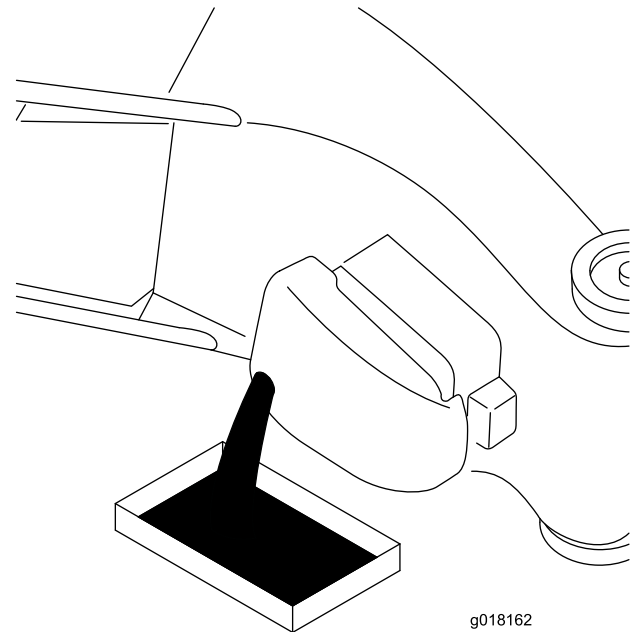

Figure 18

4. **Slowly** pour oil into the oil fill tube, wait 3 minutes, and check the engine oil level on the dipstick by wiping the dipstick clean and then inserting it into the tube (Figure 17).

Note: Max. fill: 0.59 l (20 oz.), type: SAE 30 detergent oil with an API service classification of SF, SG, SH, SJ, SL, or higher

5. Fill the engine with oil until the dipstick indicates that the engine oil level is correct as shown in [Figure 17](#). If you overfill the engine with oil, remove the excess oil.
6. Install the dipstick and tighten it securely.
7. Dispose of the used oil properly at a local recycling center.

Adjusting the Self-propel Cable

Service Interval: Every 25 hours

1. Stop the engine.
2. Pull the machine backward while slowly engaging the self-propel bar until the rear rollers lock.

Note: The self-propel bar should now be 6 cm (2-3/8 in) from the handlebar.

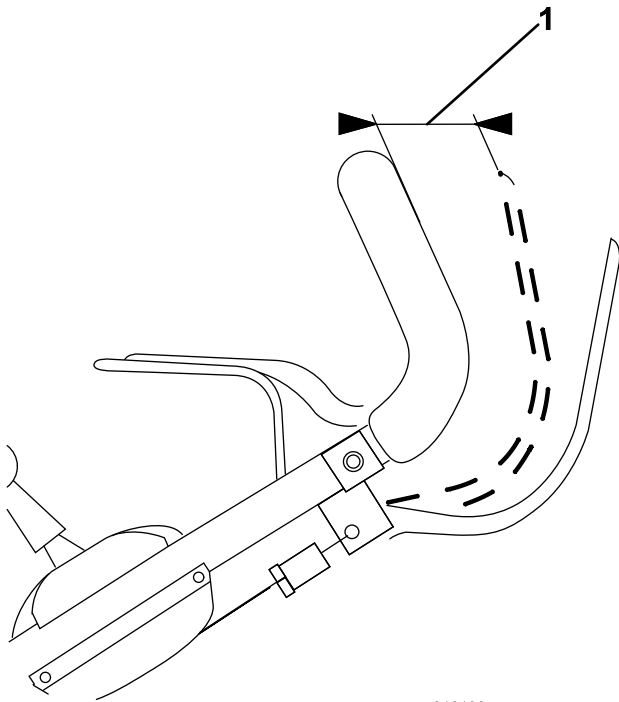
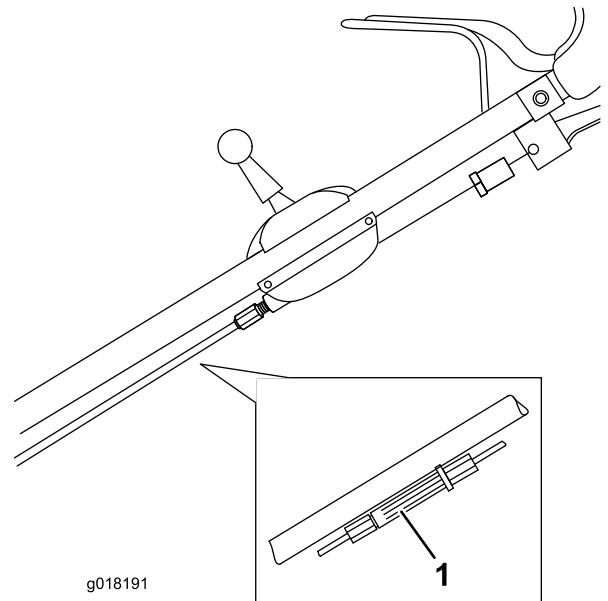

Figure 19

g018190

1. 6 cm (2-3/8 in)

3. If the distance between the self-propel bar and the handlebar is less than 6 cm (2-3/8 in), adjust the black plastic cable adjuster to set the correct distance.



g018191

Figure 20

1. Cable adjuster

4. Check the spring on the self-propel cable attached to the gearbox to ensure it is set correctly.

Note: Use the metal adjuster, and make sure that the plastic adjuster is fully wound in

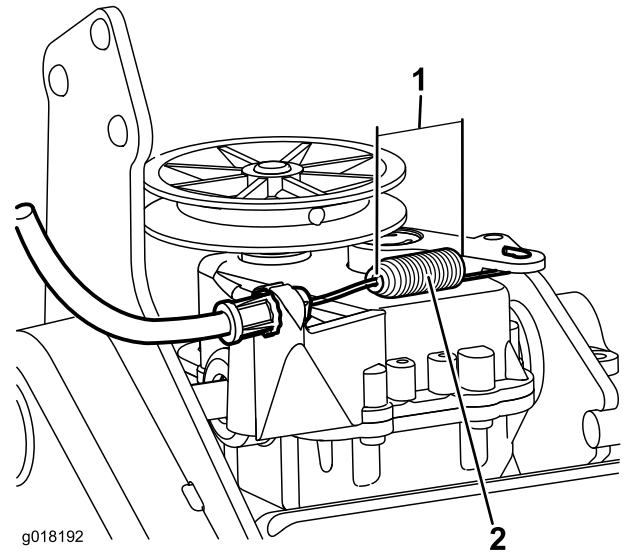

g018192

Figure 21

1. 1/2 inch (1.3 cm)
2. Self-propel spring

5. Once the spring is set correctly, tighten the inner nut to secure it in place.

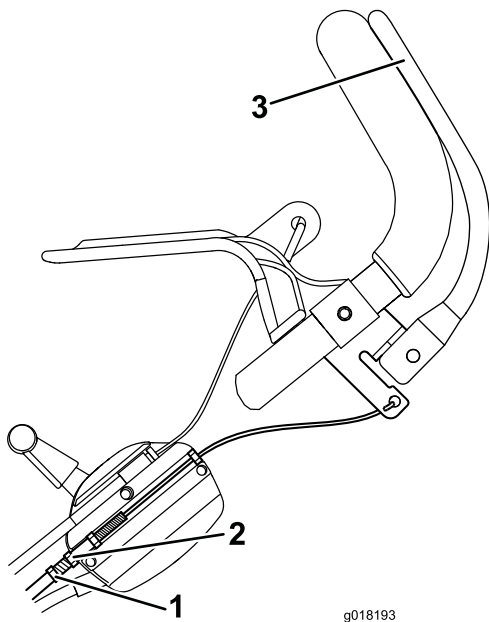

Figure 22

- | | |
|-------------------|----------------------|
| 1. Metal adjuster | 3. Self-propel cable |
| 2. Inner nut | |

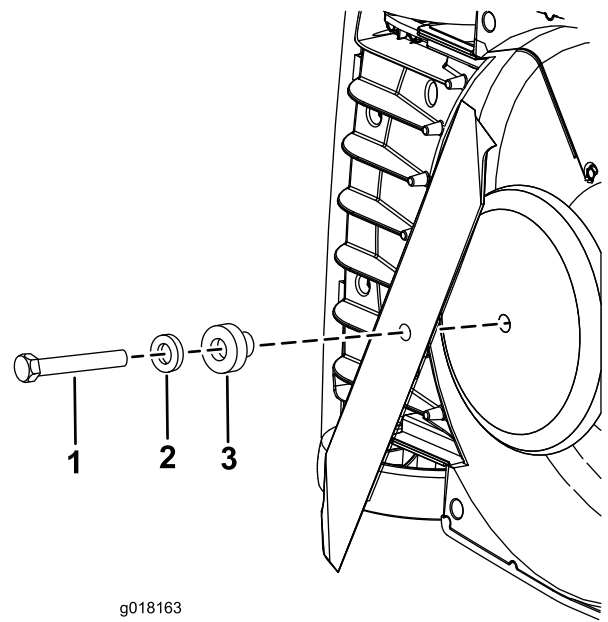

Figure 23

- | | |
|------------------|-----------|
| 1. Bolt | 3. Spacer |
| 2. Spring washer | |

Replacing the Blade

Service Interval: Every 25 hours—Replace the blade or have it sharpened (more frequently if the edge dulls quickly).

Important: *You will need a torque wrench to install the blade properly.* If you do not have a torque wrench or are uncomfortable performing this procedure, contact an Authorized Service Dealer.

Examine the blade whenever you run out of gasoline. If the blade is damaged or cracked, replace it immediately. If the blade edge is dull or nicked, have it sharpened or replace it.

⚠ WARNING

The blade is sharp; contacting the blade can result in serious personal injury.

Wear gloves when servicing the blade.

1. Disconnect the spark plug wire from the spark plug. Refer to [Preparing for Maintenance \(page 13\)](#).
2. Tip the machine onto its side with the air filter up.
3. Use a block of wood to hold the blade steady.
4. **Using a gloved hand**, grip the end of the blade.
5. Remove the bolt, washer, and spacer, then remove the blade ([Figure 23](#)).

6. Assemble the blade with the turned up edges facing toward the engine.
7. Secure the new blade in place with the bolt, washer, and spacer that you removed previously ([Figure 23](#)).
8. **Use a torque wrench to tighten the blade bolt to 54 N-m (40 ft-lb).**

Important: A bolt torqued to 40 ft-lb (54 N-m) is very tight. While holding the blade with a block of wood, put your weight behind the ratchet or wrench and tighten the bolt securely. This bolt is very difficult to overtighten.

Sharpening the Blade

Service Interval: Every 25 hours

A slightly worn blade may be re-sharpened. Both blade edges must be sharpened equally to ensure balance.

1. Remove the blade from the machine; refer to [Replacing the Blade \(page 16\)](#).
2. Clean the blade using a brush and water, then inspect the blade for signs of damage.
3. Sharpen both cutting edges with a flat file.

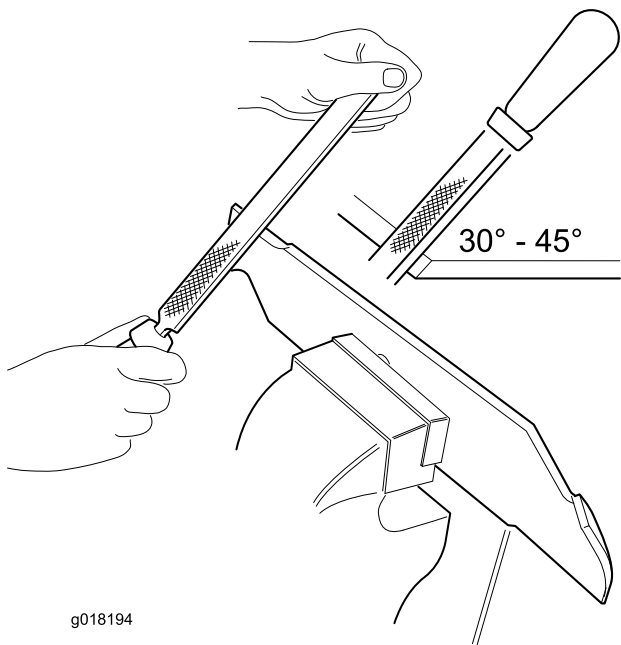

g018194

Figure 24

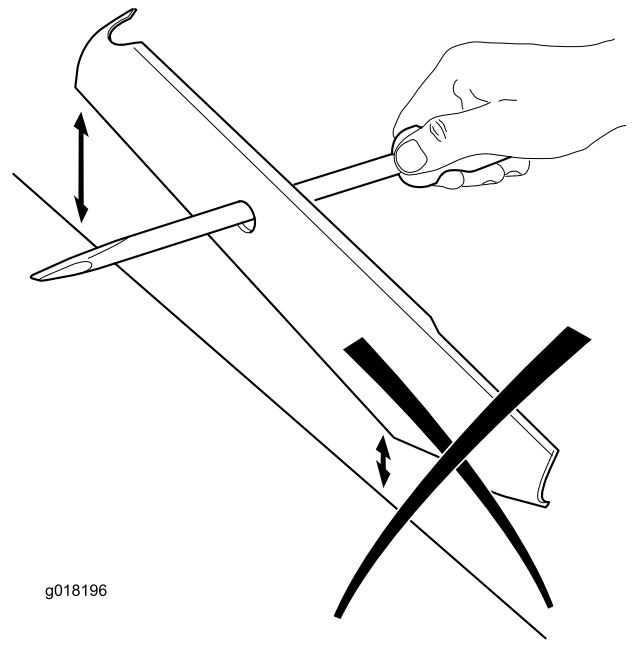

g018196

Figure 26

- Slide a screwdriver through the center hole and hold the blade horizontal.

Note: A balanced blade will remain horizontal.

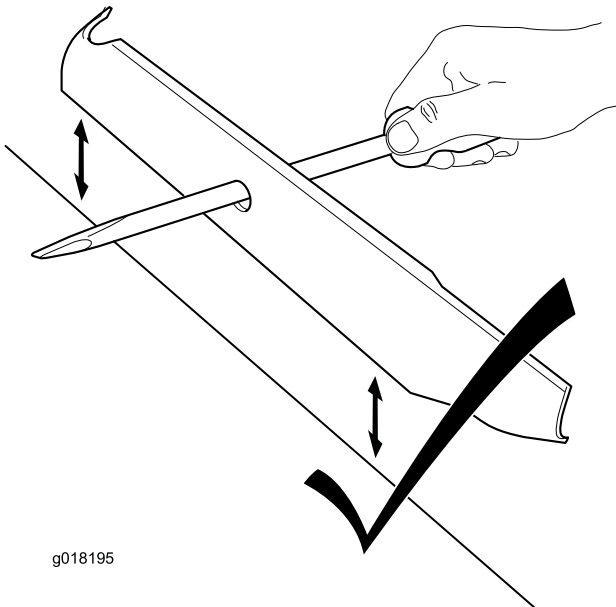

g018195

Figure 25

- Sharpen the heavy end until the blade is correctly balanced.

Note: If the blade is not balanced, the heavy end will rotate down.

Cleaning the Machine

Service Interval: Before each use or daily

⚠ WARNING

The machine may dislodge material from under the machine housing.

- Wear eye protection.
- Stay in the operating position (behind the handle) when the engine is running.
- Do not allow bystanders in the area.

For best results, clean the machine soon after you have completed mowing.

Note: Never spray the engine with water during cleaning.

- Clean up any oil or fuel spill.
- Remove all grass and debris from the engine including the exhaust/exhaust guard, the air ways in the top cowl, and the surrounding deck using a brush or compressed air (Figure 27).

Storage

Store the machine in a cool, clean, dry place.

Preparing the Machine for Storage

⚠ WARNING

Gasoline vapors can explode.

- Do not store gasoline more than 30 days.
- Do not store the machine in an enclosure near an open flame.
- Allow the engine to cool before storing it.

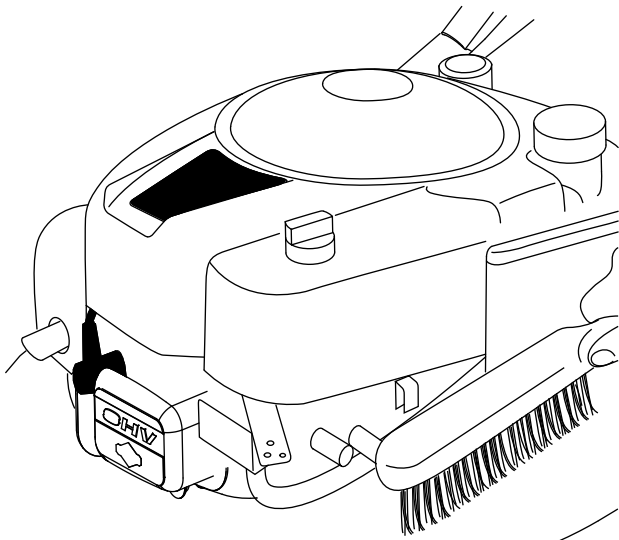

g018164

Figure 27

- Remove grass debris from the top and underside of the deck housing immediately after use (Figure 28).

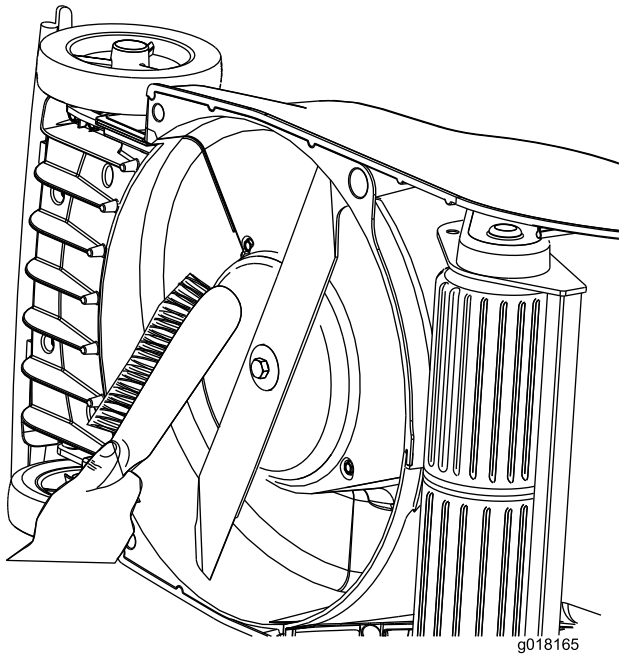

g018165

Figure 28

1. On the last refueling of the year, add fuel stabilizer to the fuel as directed by the engine manufacturer.
2. Run the machine until the engine stops from running out of fuel.
3. Allow the engine to run until it stops. When you can no longer start the engine, it is sufficiently dry.
4. Remove the wire from the spark plug and leave loose.
5. Remove the spark plug, add 15 ml (0.5 oz.) of oil through the spark plug hole, and pull the starter rope slowly several times to distribute oil throughout the cylinder to prevent cylinder corrosion during the off-season.
6. Install the spark plug and tighten it with a torque wrench to 20 N-m (15 ft-lb).
7. Tighten all nuts, bolts, and screws.

- Thoroughly clean the machine deck immediately after use on treated grass.

Folding the Handle

1. Loosen the handlebar knobs.
2. Rotate the handle forward ([Figure 29](#)).

Important: Route the cables to the outside of the handlebar knobs as you fold the upper handle.

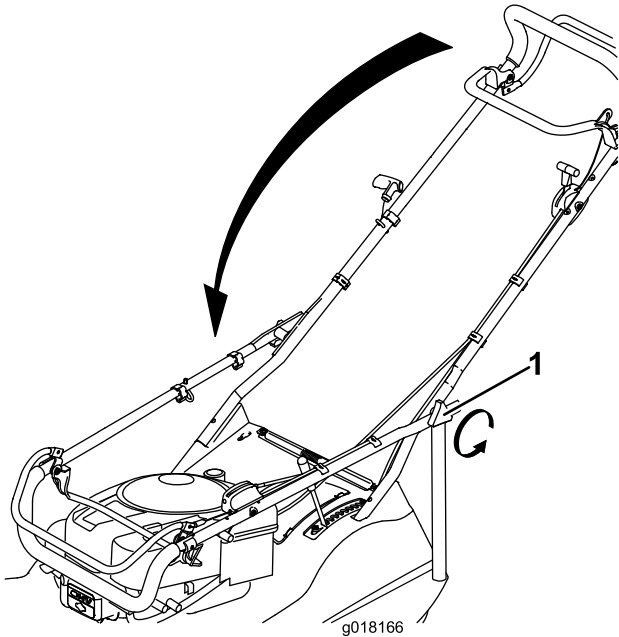

Figure 29

1. Handlebar knob
-

Removing the Machine from Storage

Refer to [1 Unfolding the Handle \(page 6\)](#) for removing the machine from storage.

Connect the wire to the spark plug.

Notes:

Notes:

Notes:

International Distributor List

Distributor:	Country:	Phone Number:	Distributor:	Country:	Phone Number:
Atlantis Su ve Sulama Sisstemleri Lt	Turkey	90 216 344 86 74	Maquiver S.A.	Colombia	57 1 236 4079
Balama Prima Engineering Equip.	Hong Kong	852 2155 2163	Maruyama Mfg. Co. Inc.	Japan	81 3 3252 2285
B-Ray Corporation	Korea	82 32 551 2076	Agrolanc Kft	Hungary	36 27 539 640
Casco Sales Company	Puerto Rico	787 788 8383	Mountfield a.s.	Czech Republic	420 255 704 220
Ceres S.A.	Costa Rica	506 239 1138	Munditol S.A.	Argentina	54 11 4 821 9999
CSSC Turf Equipment (pvt) Ltd.	Sri Lanka	94 11 2746100	Oslinger Turf Equipment SA	Ecuador	593 4 239 6970
Cyril Johnston & Co.	Northern Ireland	44 2890 813 121	Oy Hako Ground and Garden Ab	Finland	358 987 00733
Equiver	Mexico	52 55 539 95444	Parkland Products Ltd.	New Zealand	64 3 34 93760
Femco S.A.	Guatemala	502 442 3277	Prato Verde S.p.A.	Italy	39 049 9128 128
G.Y.K. Company Ltd.	Japan	81 726 325 861	Prochaska & Cie	Austria	43 1 278 5100
Geomechaniki of Athens	Greece	30 10 935 0054	RT Cohen 2004 Ltd.	Israel	972 986 17979
Guandong Golden Star	China	86 20 876 51338	Riversa	Spain	34 9 52 83 7500
Hako Ground and Garden	Sweden	46 35 10 0000	Sc Svend Carlsen A/S	Denmark	45 66 109 200
Hako Ground and Garden	Norway	47 22 90 7760	Solvret S.A.S.	France	33 1 30 81 77 00
Hayter Limited (U.K.)	United Kingdom	44 1279 723 444	Spypros Stavrinides Limited	Cyprus	357 22 434131
Hydroturf Int. Co Dubai	United Arab Emirates	97 14 347 9479	Surge Systems India Limited	India	91 1 292299901
Hydroturf Egypt LLC	Egypt	202 519 4308	T-Markt Logistics Ltd.	Hungary	36 26 525 500
Irriamc	Portugal	351 21 238 8260	Toro Australia	Australia	61 3 9580 7355
Irrigation Products Int'l Pvt Ltd.	India	0091 44 2449 4387	Toro Europe NV	Belgium	32 14 562 960
Jean Heybroek b.v.	Netherlands	31 30 639 4611			

European Privacy Notice

The Information Toro Collects

Toro Warranty Company (Toro) respects your privacy. In order to process your warranty claim and contact you in the event of a product recall, we ask you to share certain personal information with us, either directly or through your local Toro company or dealer.

The Toro warranty system is hosted on servers located within the United States where privacy law may not provide the same protection as applies in your country.

BY SHARING YOUR PERSONAL INFORMATION WITH US, YOU ARE CONSENTING TO THE PROCESSING OF YOUR PERSONAL INFORMATION AS DESCRIBED IN THIS PRIVACY NOTICE.

The Way Toro Uses Information

Toro may use your personal information to process warranty claims, to contact you in the event of a product recall and for any other purpose which we tell you about. Toro may share your information with Toro's affiliates, dealers or other business partners in connection with any of these activities. We will not sell your personal information to any other company. We reserve the right to disclose personal information in order to comply with applicable laws and with requests by the appropriate authorities, to operate our systems properly or for our own protection or that of other users.

Retention of your Personal Information

We will keep your personal information as long as we need it for the purposes for which it was originally collected or for other legitimate purposes (such as regulatory compliance), or as required by applicable law.

Toro's Commitment to Security of Your Personal Information

We take reasonable precautions in order to protect the security of your personal information. We also take steps to maintain the accuracy and current status of personal information.

Access and Correction of your Personal Information

If you would like to review or correct your personal information, please contact us by email at legal@toro.com.

Australian Consumer Law

Australian customers will find details relating to the Australian Consumer Law either inside the box or at your local Toro Dealer.



The Toro Total Coverage Guarantee

A Limited Warranty

Conditions and Products Covered

The Toro® Company and its affiliate, Toro Warranty Company, pursuant to an agreement between them, jointly warrant your Toro Commercial product ("Product") to be free from defects in materials or workmanship for two years or 1500 operational hours*, whichever occurs first. This warranty is applicable to all products with the exception of Aerators (refer to separate warranty statements for these products). Where a warrantable condition exists, we will repair the Product at no cost to you including diagnostics, labor, parts, and transportation. This warranty begins on the date the Product is delivered to the original retail purchaser.

* Product equipped with an hour meter.

Instructions for Obtaining Warranty Service

You are responsible for notifying the Commercial Products Distributor or Authorized Commercial Products Dealer from whom you purchased the Product as soon as you believe a warrantable condition exists. If you need help locating a Commercial Products Distributor or Authorized Dealer, or if you have questions regarding your warranty rights or responsibilities, you may contact us at:

Commercial Products Service Department
Toro Warranty Company
8111 Lyndale Avenue South
Bloomington, MN 55420-1196
E-mail: commercial.warranty@toro.com

Owner Responsibilities

As the Product owner, you are responsible for required maintenance and adjustments stated in your Operator's Manual. Failure to perform required maintenance and adjustments can be grounds for disallowing a warranty claim.

Items and Conditions Not Covered

Not all product failures or malfunctions that occur during the warranty period are defects in materials or workmanship. This warranty does not cover the following:

- Product failures which result from the use of non-Toro replacement parts, or from installation and use of add-on, or modified non-Toro branded accessories and products. A separate warranty may be provided by the manufacturer of these items.
- Product failures which result from failure to perform recommended maintenance and/or adjustments. Failure to properly maintain your Toro product per the Recommended Maintenance listed in the *Operator's Manual* can result in claims for warranty being denied.
- Product failures which result from operating the Product in an abusive, negligent or reckless manner.
- Parts subject to consumption through use unless found to be defective. Examples of parts which are consumed, or used up, during normal Product operation include, but are not limited to, brakes pads and linings, clutch linings, blades, reels, bed knives, tines, castor wheels, tires, filters, belts, and certain sprayer components such as diaphragms, nozzles, and check valves, etc.
- Failures caused by outside influence. Items considered to be outside influence include, but are not limited to, weather, storage practices,

contamination, use of unapproved coolants, lubricants, additives, fertilizers, water, or chemicals, etc.

- Normal noise, vibration, wear and tear, and deterioration.
- Normal "wear and tear" includes, but is not limited to, damage to seats due to wear or abrasion, worn painted surfaces, scratched decals or windows, etc.

Parts

Parts scheduled for replacement as required maintenance are warranted for the period of time up to the scheduled replacement time for that part. Parts replaced under this warranty are covered for the duration of the original product warranty and become the property of Toro. Toro will make the final decision whether to repair any existing part or assembly or replace it. Toro may use remanufactured parts for warranty repairs.

Note Regarding Deep Cycle Battery Warranty:

Deep cycle batteries have a specified total number of kilowatt-hours they can deliver during their lifetime. Operating, recharging, and maintenance techniques can extend or reduce total battery life. As the batteries in this product are consumed, the amount of useful work between charging intervals will slowly decrease until the battery is completely worn out. Replacement of worn out batteries, due to normal consumption, is the responsibility of the product owner. Battery replacement may be required during the normal product warranty period at owner's expense.

Maintenance is at Owner's Expense

Engine tune-up, lubrication cleaning and polishing, replacement of Items and Conditions Not Covered filters, coolant, and completing Recommended Maintenance are some of the normal services Toro products require that are at the owner's expense.

General Conditions

Repair by an Authorized Toro Distributor or Dealer is your sole remedy under this warranty.

Neither The Toro Company nor Toro Warranty Company is liable for indirect, incidental or consequential damages in connection with the use of the Toro Products covered by this warranty, including any cost or expense of providing substitute equipment or service during reasonable periods of malfunction or non-use pending completion of repairs under this warranty. Except for the Emissions warranty referenced below, if applicable, there is no other express warranty.

All implied warranties of merchantability and fitness for use are limited to the duration of this express warranty. Some states do not allow exclusions of incidental or consequential damages, or limitations on how long an implied warranty lasts, so the above exclusions and limitations may not apply to you.

This warranty gives you specific legal rights, and you may also have other rights which vary from state to state.

Countries Other than the United States or Canada

Customers should contact their Toro Distributor (Dealer) to obtain guarantee policies for your country, province, or state. If for any reason you are dissatisfied with your Distributor's service or have difficulty obtaining guarantee information, contact the Toro importer. If all other remedies fail, you may contact us at Toro Warranty Company.