



Count on it.

Parts Catalog

**Power Max Heavy Duty 928 OXE
Snowthrower**

Model No. 38822—Serial No. 313000001 and Up



Ordering Replacement Parts

To order replacement parts, please supply the part number, the quantity, and the description of each part desired.

Understanding Reference Numbers

Each identified part in an illustration has a reference number. The reference number for a part also appears in the parts list, along with other information about the part.

This catalog uses two special reference number formats, one to indicate parts in a service assembly and another to indicate the quantity of a given part in an illustration.

Service Assembly Reference Numbers

Parts in service assemblies have reference numbers in the form a:b. The a represents the reference number of the entire service assembly and the b represents a sequential number unique to each part within the service assembly.

For example, a wheel assembly might be identified by reference number 6, the tire by 6:1, the valve by 6:2, and the wheel by 6:3. When you order the assembly identified by reference number 6, you receive all parts identified by reference numbers 6:1, 6:2, and 6:3. However, you may also order any part individually. Reference numbers of this type appear in illustration and in parts lists.

Reference Numbers Indicating Quantity

In an illustration, if a reference number indicates more than one part, the reference number has the form nX y. The n represents the quantity of the part, the X is the multiplication symbol, and the y represents the reference number.

For example, in an illustration, the reference number 2X 37 means that two of the parts identified by reference number 37 are indicated.

List of Abbreviations

AR: as required

ASM: assembly

BBC: blade brake control

BHTF: button head thread forming

CARR: carriage

CCW: counter clockwise

CW: clockwise

DEG: degrees

DPA: Dual Point Adjustment

ECM: electronic control module

EXT: external

FH: flat head

GA: gauge

HD: heavy-duty

HF: hex flange

HH: hex head

HHF: hex head flange

HHFTF: hex head flange thread forming

HJ: hex jam

HLH: hex lag head

HOC: height-of-cut

HSBH: hex socket button head

HSFH: hex socket flat head

HSH: hex socket head

HWH: hex washer head

HWHTF: hex washer head thread forming

HYD: hydraulic

LH: left hand

LP: Liquefied Petroleum Gas

LPG: Liquefied Petroleum Gas

NI: nylon insert

NPTF: national pipe thread fine

PFH: phillips flat head

PPH: phillips pan head

PPHTF: phillips pan head thread forming

PRH: phillips round head

PTH: phillips truss head

PTO: power-take-off

RH: right hand

ROPS: roll-over protection system

RRB: rear roller brush

SFH: slotted fillister head

SHH: slotted hex head

SHWH: slotted hex washer head

SPH: slotted pan head

SQH: square head

SRH: slotted round head

STD: standard

TAP: self tapping

TTH: torx truss head

Contents

Housing Assembly	4
Traction Frame Assembly	5
Idler and Linkage Assembly	6
Auger and Impeller Assembly	8
28 Inch Auger Gearcase Assembly No. 108-7329	9
Impeller Assembly	10
Engine Assembly	11
Engine Decal Assembly	12
Fuel Tank and Recoil Engine Assembly	13
Crankcase Engine Assembly	14
Muffler, Cylinder Head and Carburetor Engine Assembly	16
Chute Assembly	18
Lever Chute Control Assembly	19
Lower Handle and Headlamp Assembly	20
Handle and Control Assembly	21
Wheel Clutch Assembly	22
Wheel Clutch Sprocket Assembly	24
Attachments and Accessories	25

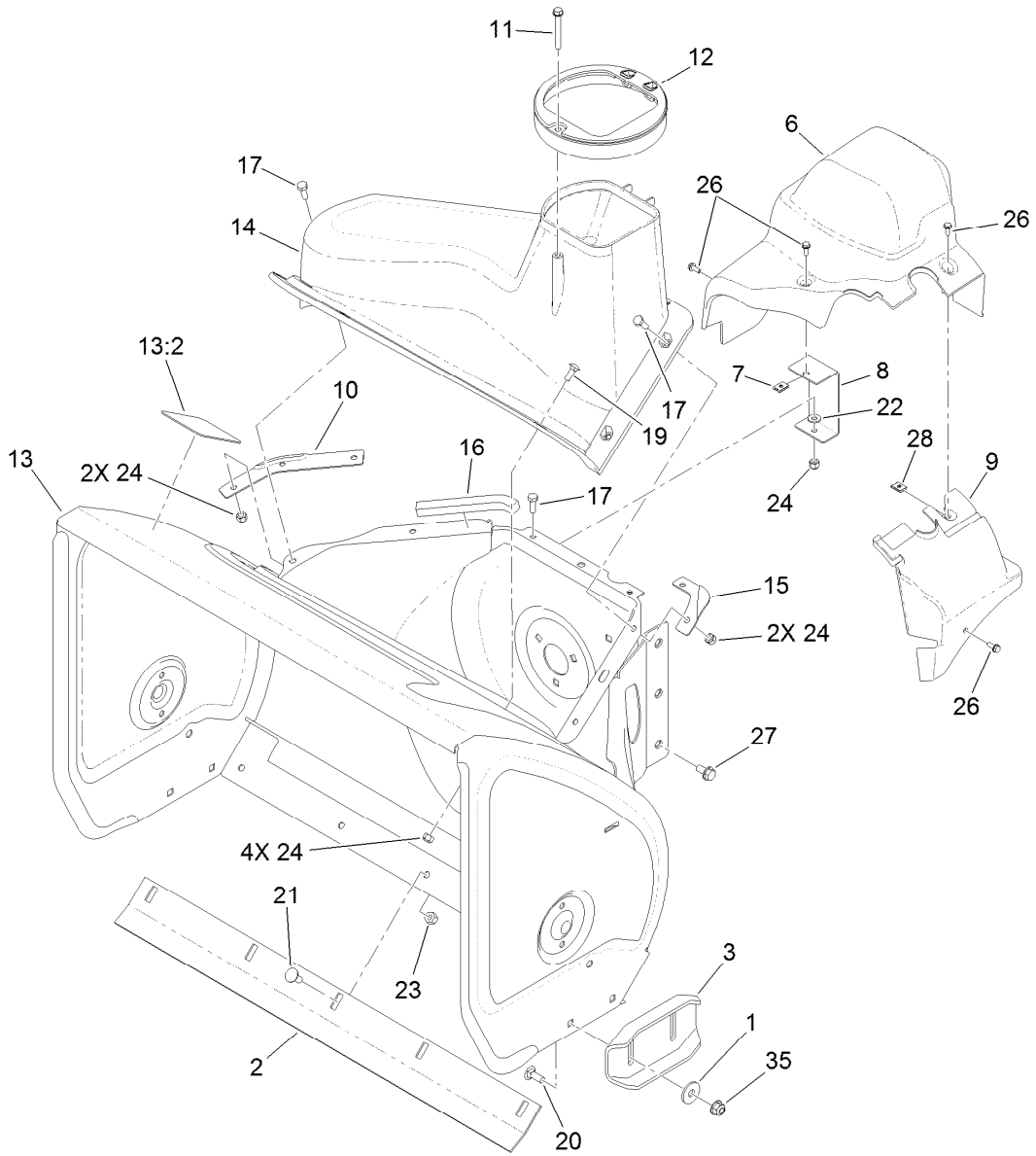

Housing Assembly

<i>Ref.</i>	<i>Part Number</i>	<i>Qty.</i>	<i>Description</i>	<i>Ref.</i>	<i>Part Number</i>	<i>Qty.</i>	<i>Description</i>
1	52-2861	4	Washer	15	108-0039-03	1	Seal
2	106-4573-01	1	Scraper-Fixed	16	120-0124	1	Seal-Housing
3	120-3098-03	2	Skid	17	321-4	7	Screw-HH
6	119-1563	1	Cover-Belt	19	3229-1	4	Bolt-CARR
7	107-1013	1	Nut-Speed, U-Type	20	3230-16	4	Screw-CARR
8	107-1014-03	1	Bracket-Cover, Clip Nut	21	3230-23	5	Screw-CARR
9	107-1016	1	Cover-Extension, Belt	22	3256-22	1	Washer-Flat
10	107-1017-03	1	Seal-Flange, Cover	23	3296-29	5	Nut-Lock, NI
11	107-3003	1	Screw-Plastite	24	3296-42	11	Nut-Lock, NI
12	107-3006	1	Guide-Chute	26	32144-112	4	Screw-HWH
13	107-3824	1	Housing-Auger, 28 Inch	27	32144-14	6	Screw-HWHTF
13:2	107-3040	1	Decal-Danger, Auger	28	701493	1	Nut-Speed
14	108-0017	1	Cover	35	104-8300	4	Nut-Flange, NI

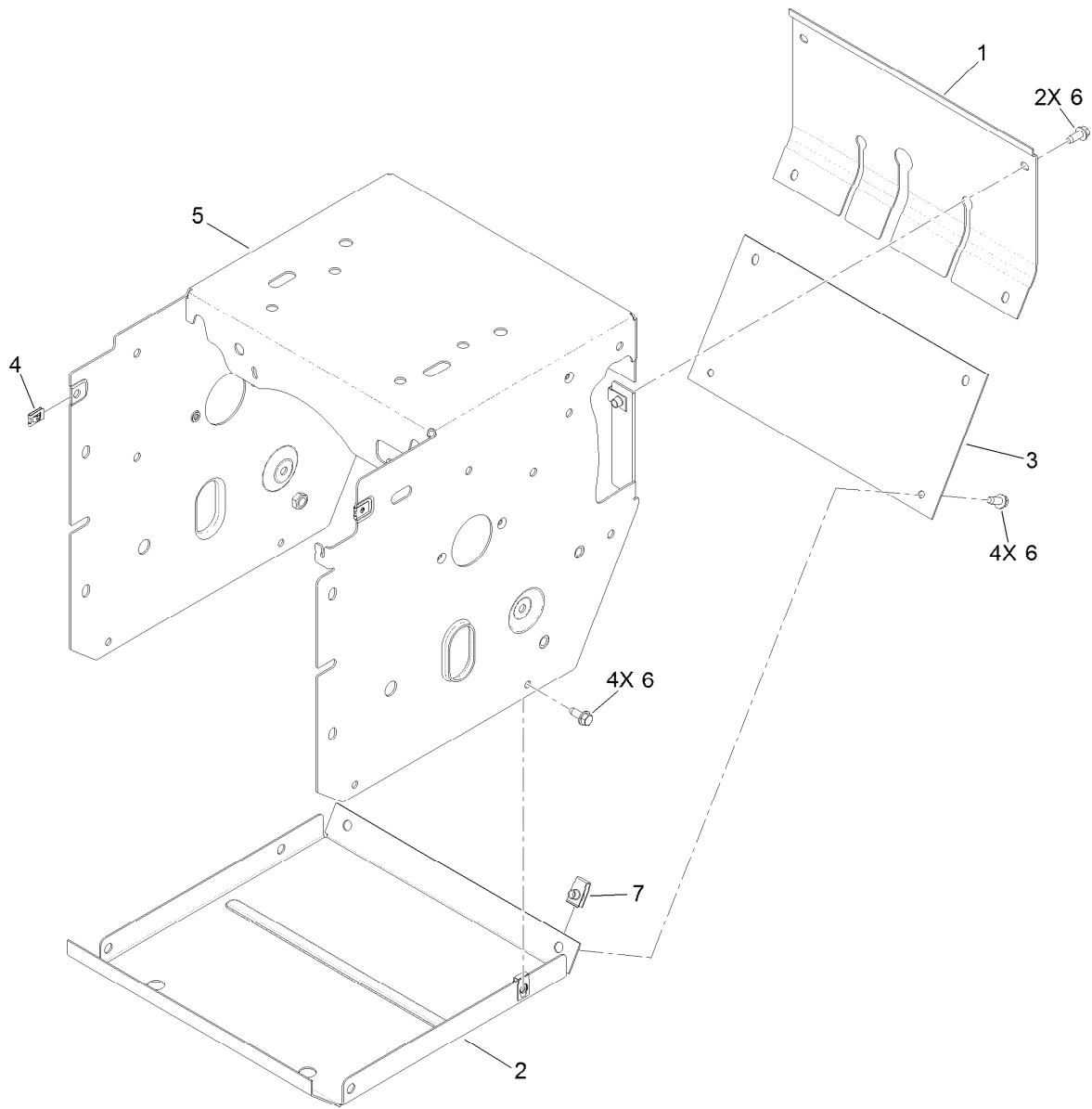

Traction Frame Assembly

<i>Ref.</i>	<i>Part Number</i>	<i>Qty.</i>	<i>Description</i>
1	108-0022-01	1	Cover-Upper
2	106-7330-01	1	Pan-Bottom
3	106-7345-01	1	Cover-Lower
4	107-1013	2	Nut-Speed, U-Type
5	120-9832-01	1	Traction Frame ASM
6	32144-10	10	Screw-HWH
7	107069	7	Clip

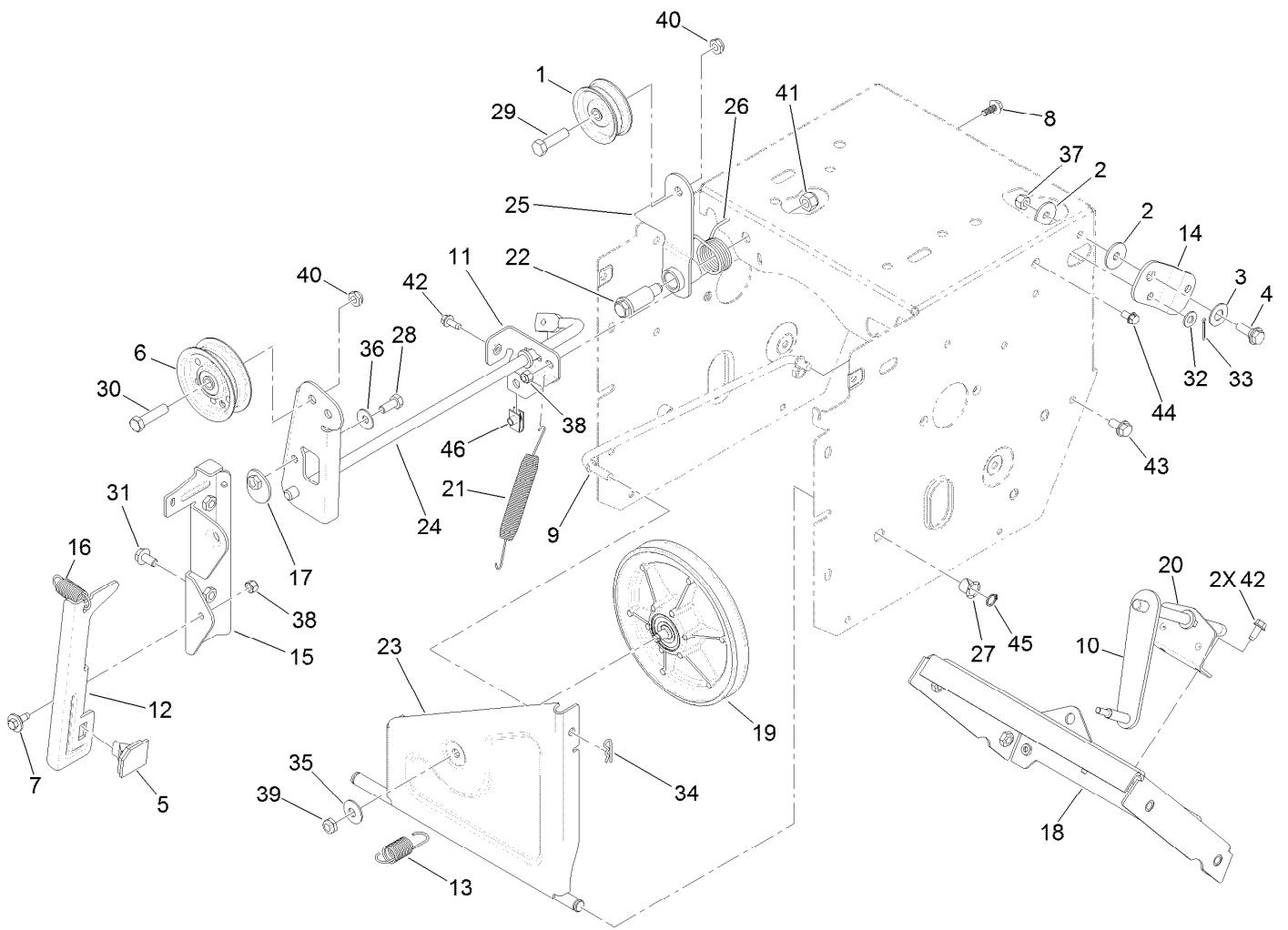

Idler and Linkage Assembly

<i>Ref.</i>	<i>Part Number</i>	<i>Qty.</i>	<i>Description</i>	<i>Ref.</i>	<i>Part Number</i>	<i>Qty.</i>	<i>Description</i>
1	3-4244	1	Pulley-Idler	22	108-5056	1	Bolt-Shoulder
2	5-4460	2	Washer-Pivot	23	108-7307	1	Friction Wheel Bracket ASM
3	25-5640	1	Washer	24	120-0144-03	1	Impeller Clutch ASM
4	27-0410	1	Screw-Shoulder	25	120-0148	1	Arm-Traction Idler ASM
5	66-8060	1	Pad-Brake	26	120-3060	1	Spring-Torsion
6	92-7104	1	Pulley-Idler	27	256-257	2	Bushing-Nyliner
7	92-9698	1	Screw-Shoulder	28	322-3	1	Screw-HH
8	99-6810	1	Screw-HH	29	323-29	1	Screw-HH
9	106-4467	1	Link-Control, Speed	30	323-8	1	Screw-HH
10	106-7268	1	Lever-Control, Traction	31	3234-7	2	Screw-HHF
11	120-9824	1	Bracket-Clutch, Impeller	32	3256-23	1	Washer-Flat
12	107-1000	1	Arm-Brake	33	3272-4	1	Pin-Cotter
13	107-1003	1	Spring-Extension	34	3290-307	1	Pin-Hair
14	107-1011	1	Bellcrank-Drive	35	3290-340	1	Washer-Belleville
15	107-1039	1	Bracket-Idler, Impeller	36	3290-456	1	Washer-Belleville
16	107-1045	1	Spring-Extension	37	3296-29	1	Nut-Lock, NI
17	107-1047	1	Nut	38	3296-42	2	Nut-Lock, NI
18	108-0026-01	1	Shift Plate ASM	39	3296-5	1	Nut-Lock
19	108-0031	1	Traction Pulley ASM	40	3296-59	2	Nut-Lock, NI
20	108-0036	1	Bracket-Rod, Shift	41	3296-76	1	Nut-Lock, NI
21	108-2976	1	Spring-Extension	42	32144-10	3	Screw-HWH

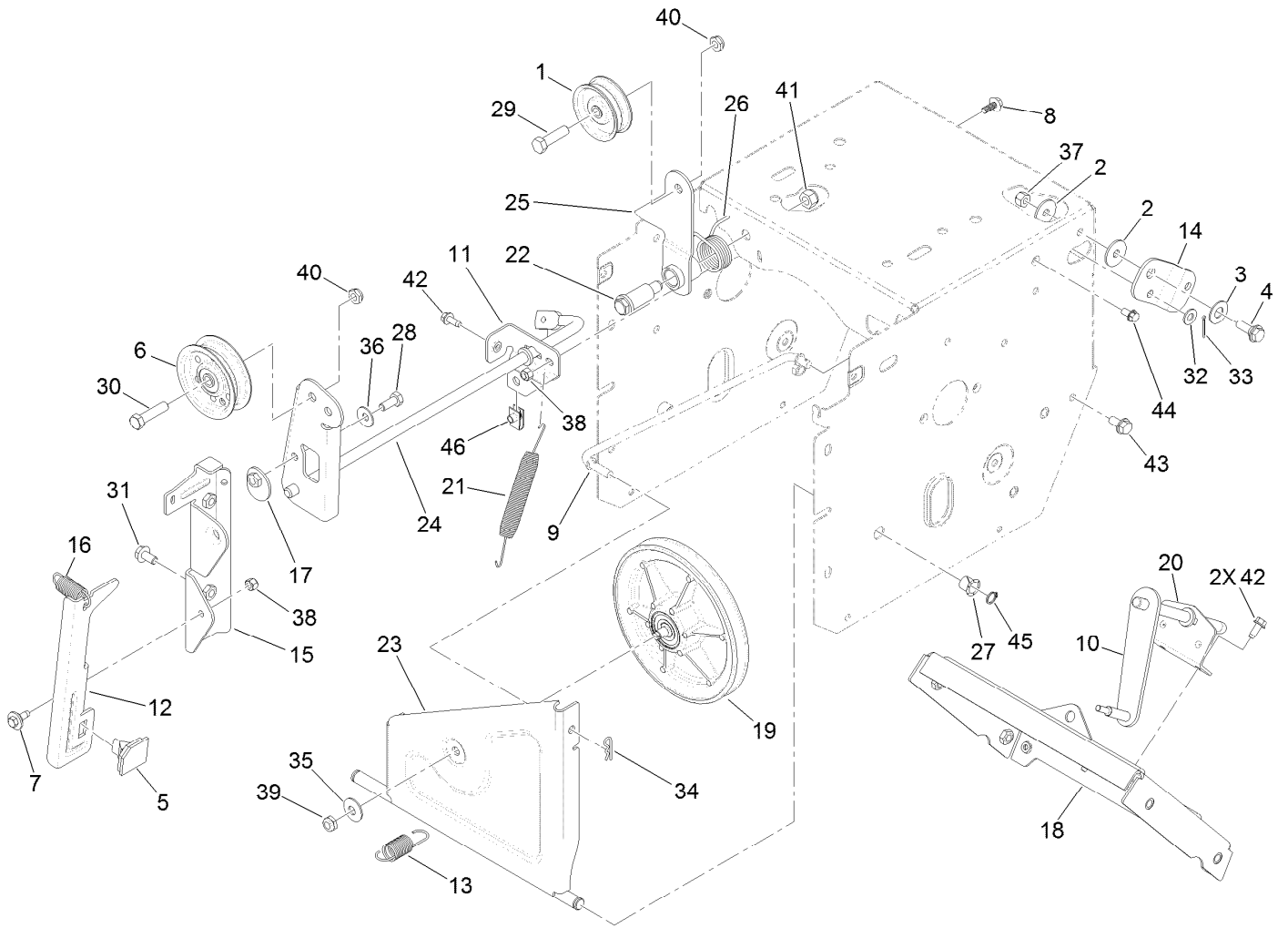

Idler and Linkage Assembly (continued)

<i>Ref.</i>	<i>Part Number</i>	<i>Qty.</i>	<i>Description</i>	<i>Ref.</i>	<i>Part Number</i>	<i>Qty.</i>	<i>Description</i>
43	32144-14	4	Screw-HWHTF	45	32151-61	2	Ring-Retaining
44	32144-4	1	Screw-HWH	46	107069	1	Clip

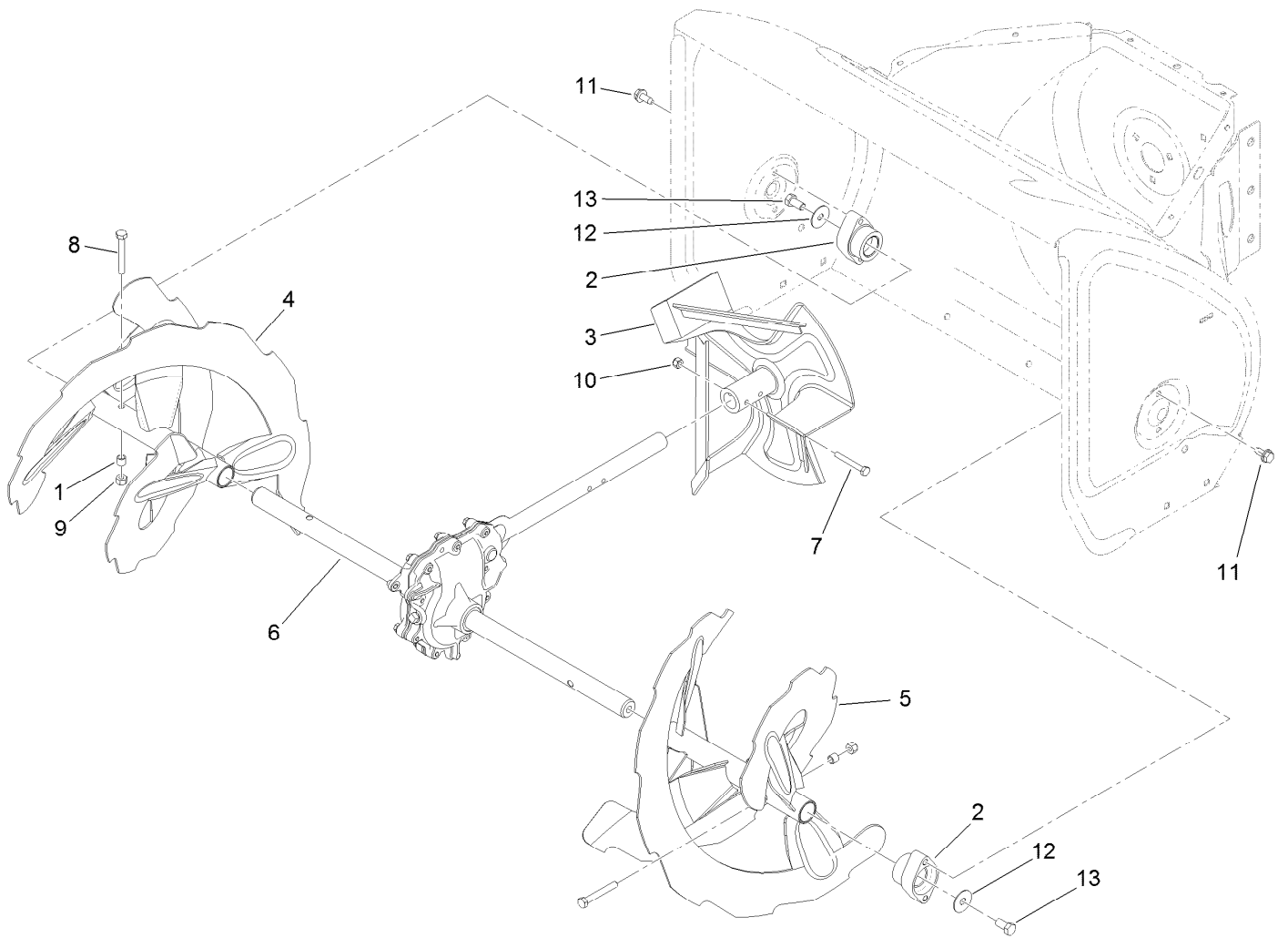

Auger and Impeller Assembly

Ref.	Part Number	Qty.	Description
1	1-633545	2	Spacer
2	106-4570	2	Auger-Bearing
3	106-4576-03	1	Impeller ASM
4	106-7291-03	1	Auger-RH
5	106-7301-03	1	LH Auger ASM
6	108-7329	1	28 Inch Auger Gearcase ASM
7	321-11	2	Screw-HH
8	322-11	2	Screw-HH
9	3296-29	2	Nut-Lock, NI
10	3296-42	2	Nut-Lock, NI
11	32144-70	4	Screw-HWHTF
12	3-0750	2	Washer
13	323-4	2	Screw-HH

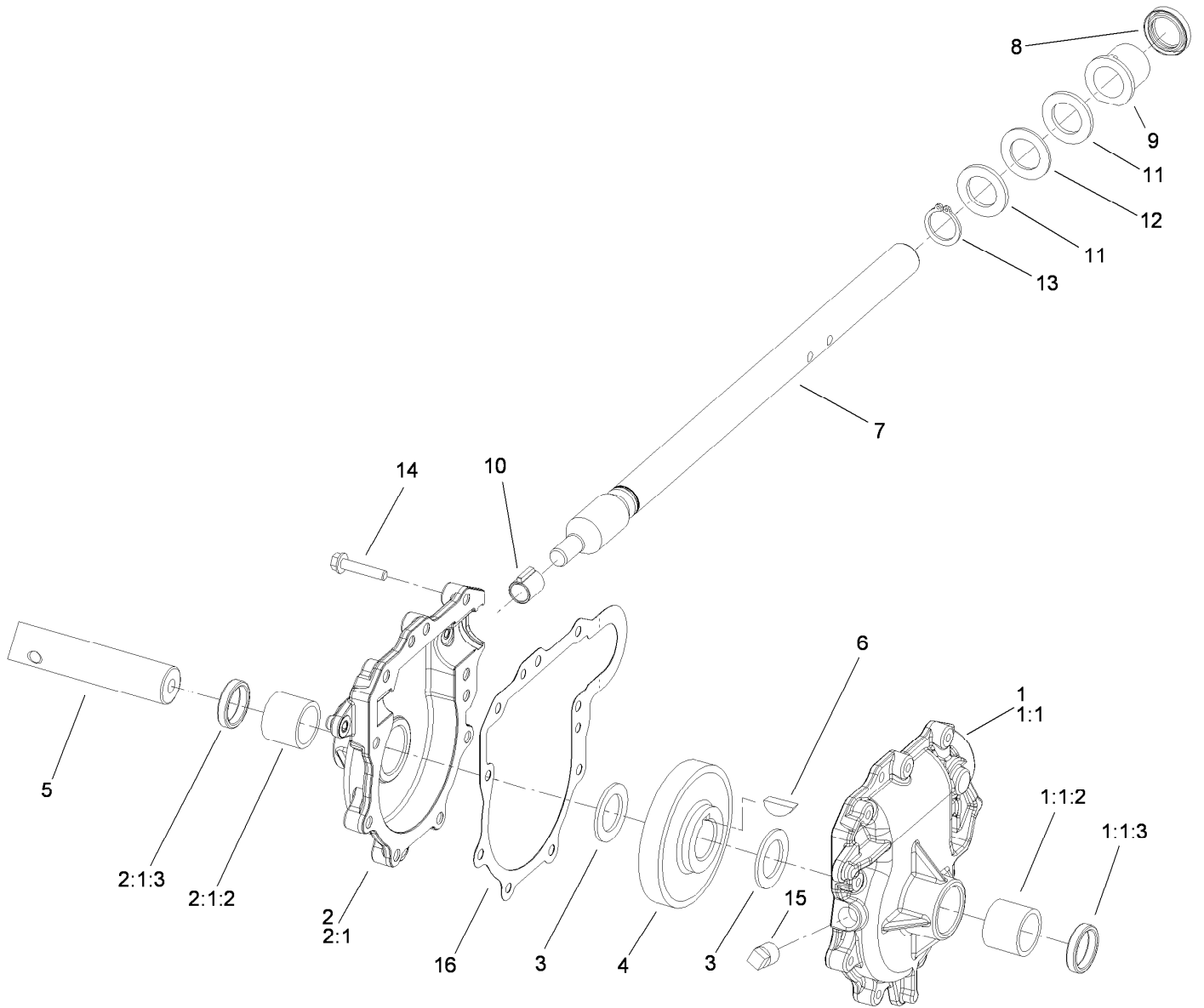

28 Inch Auger Gearcase Assembly No. 108-7329

Ref.	Part Number	Qty.	Description	Ref.	Part Number	Qty.	Description
1	108-7325	1	LH Auger Gearcase ASM	6	3257-10	1	Key-Woodruff
1:1		1	Gearcase-Auger, LH ●	7	66-7811	1	Shaft-Impeller
1:1:2	112-6635	1	Bushing-Sleeve	8	253-149	1	Seal-Oil
1:1:3	7-0045	1	Seal-Oil	9	37-6560	1	Bushing-Input
2	108-7327	1	RH Auger Gearcase ASM	10	62-1150	1	Bushing-Worm
2:1		1	Gearcase-Auger, RH ●	11	252-78	2	Washer-Thrust
2:1:2	112-6635	1	Bushing-Sleeve	12	252-76	1	Bearing-Thrust
2:1:3	7-0045	1	Seal-Oil	13	32151-33	1	Ring-Retaining, EXT
3	252-71	2	Washer-Thrust	14	108-4862	9	Screw-HWHTF
4	62-0120	1	Gear-Helical	15	281-1	1	Plug-Pipe, SQH
5	106-4421	1	Shaft-Auger	16	108-7330	1	Gasket-Gearcase, Auger

● Not serviced separately

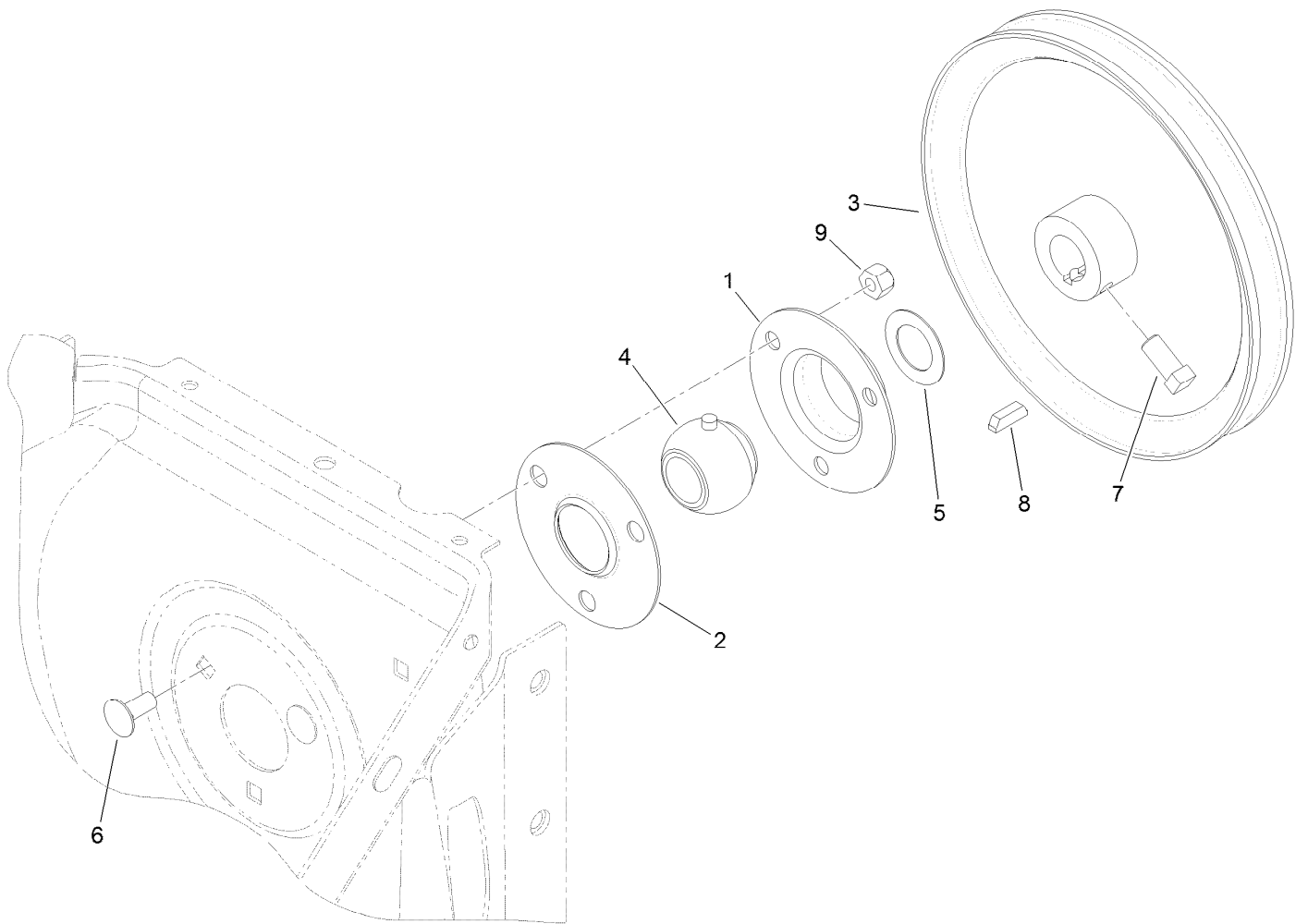

Impeller Assembly

Ref.	Part Number	Qty.	Description
1	26-6110	1	Flange-Cup, Bearing
2	26-6120	1	Flange-Cup, Bearing
3	62-1300	1	Pulley-Impeller
4	63-3450	1	Bearing-Ball
5	252-80	1	Washer-Thrust
6	3230-23	3	Screw-CARR
7	3242-4	2	Screw-Set, SQH
8	3257-23	1	Key-Woodruff
9	3296-29	3	Nut-Lock, NI

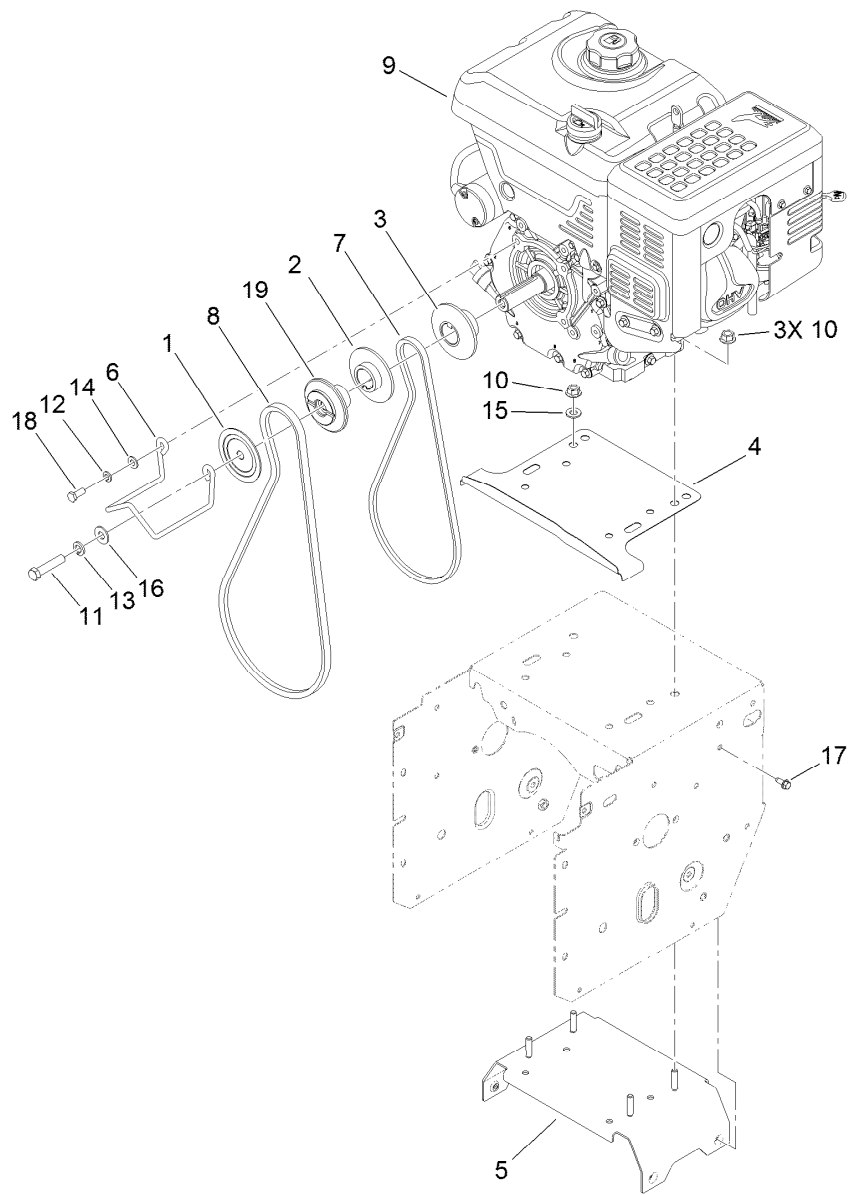

Engine Assembly

<i>Ref.</i>	<i>Part Number</i>	<i>Qty.</i>	<i>Description</i>	<i>Ref.</i>	<i>Part Number</i>	<i>Qty.</i>	<i>Description</i>
1	62-0940	1	Sheave-Half, Impeller	11	3212-8	1	Screw-HH
2	121-6603	1	Pulley-Engine, Traction	12	3253-4	2	Washer-Lock
3	106-7334	1	Sheave-Half, Traction	13	3253-6	1	Washer-Lock
4	117-6022-01	1	Shield-Drive	14	3256-23	2	Washer-Flat
5	119-1560	1	Frame Brace ASM	15	3256-24	1	Washer-Flat
6	119-1562	1	Guide-Belt	16	3256-4	1	Washer-Flat
7	119-1564	1	Belt-V	17	32144-10	4	Screw-HWH
8	125-1145	1	Belt-V	18	33114-020	2	Screw-HH
9	120-4424	1	Engine-Lc175Fds-1	19	121-6602	1	Pulley-Engine, Impeller
10	120-3067	4	Nut-Flange				

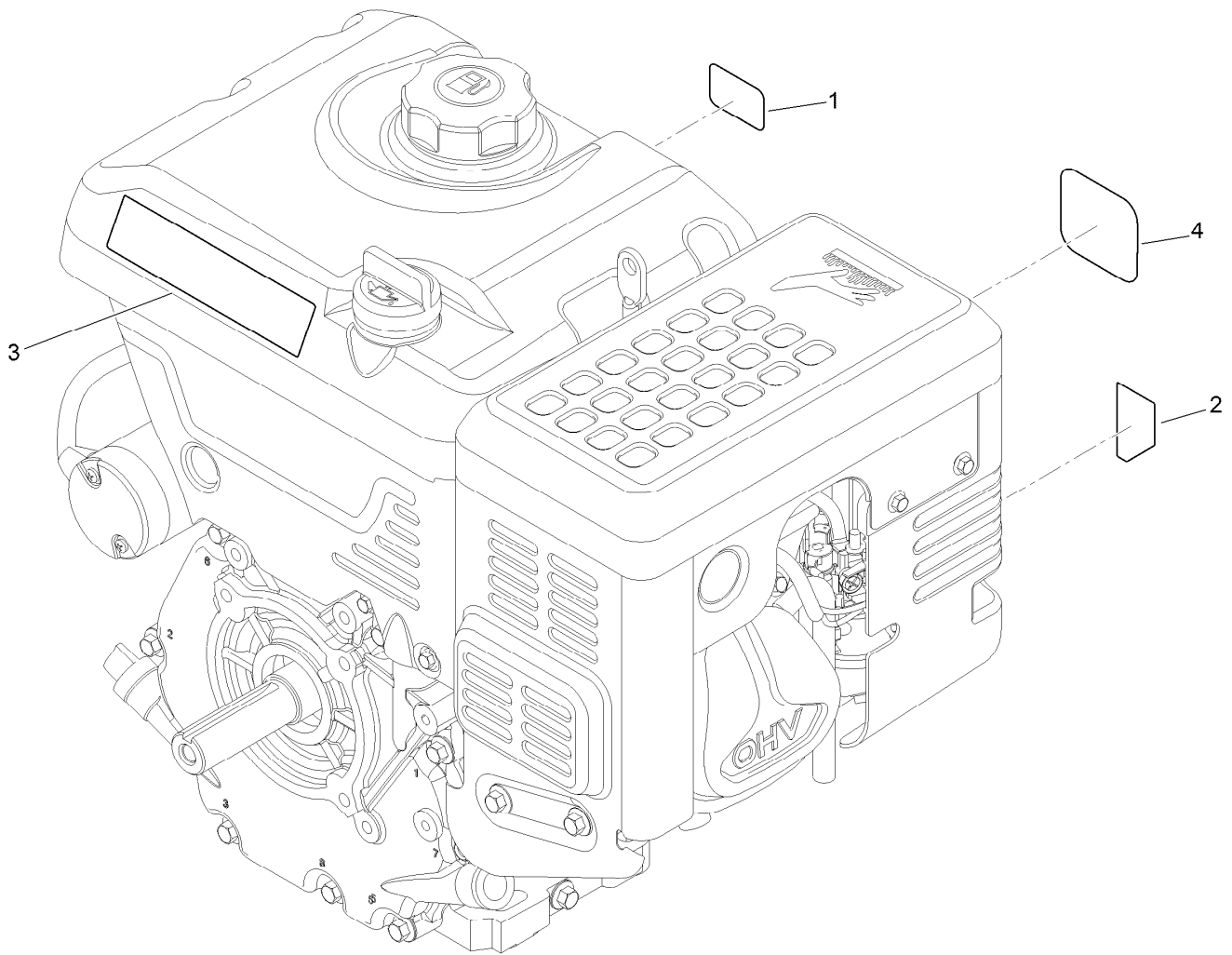

Engine Decal Assembly

<i>Ref.</i>	<i>Part Number</i>	<i>Qty.</i>	<i>Description</i>
1	125-1102	1	Decal-Throttle
2	120-9805	1	Decal-Control, Engine
3	120-9807	1	Decal-Engine
4	120-9810	1	Decal-Recoil

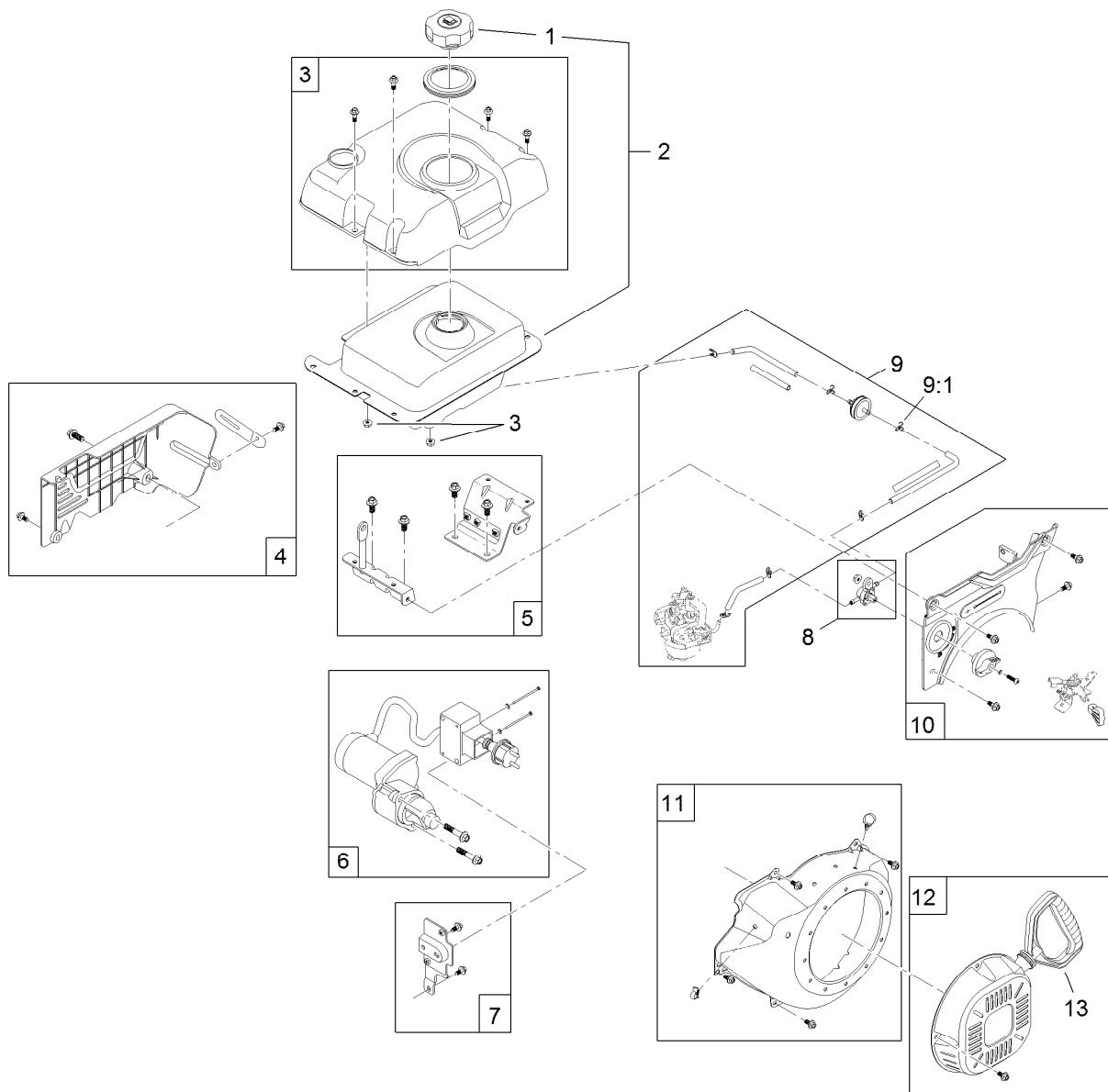

Fuel Tank and Recoil Engine Assembly

Ref.	Part Number	Qty.	Description
1	121-0257	1	Cap-Fuel
2	121-0414	1	Fuel Tank And Cap Kit
3	121-0349	1	Fuel Tank Cover Kit
4	121-0347	1	Rear Panel And Hardware Kit
5	121-0351	1	Tank Mount Bracket Kit
6	121-0446	1	Starter Kit
7	121-4103	1	Switch Box Bracket Kit
8	121-4109	1	Fuel Shut-Off Valve Kit
9	121-0353	1	Complete Fuel Line Kit
9:1	121-0087	6	Clamp-Hose
10	121-4105	1	Front Panel Kit
11	121-0274	1	Recoil Shroud Kit
12	121-0342	1	Recoil Kit
13	121-0287	1	Handle-Recoil

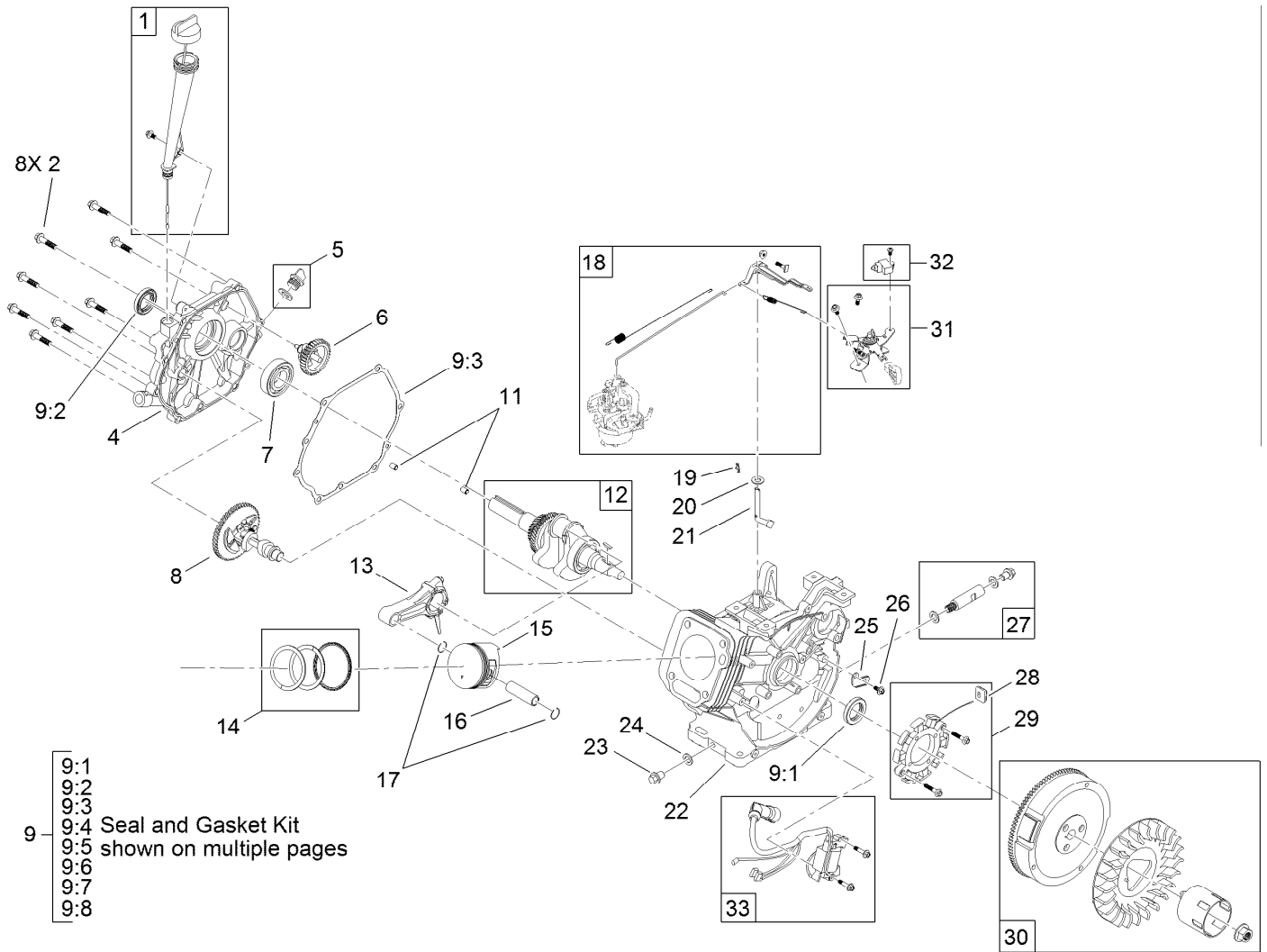

Crankcase Engine Assembly

Ref.	Part Number	Qty.	Description	Ref.	Part Number	Qty.	Description
1	121-0361	1	Oil Fill Kit	12	121-0241	1	Crankshaft ASM
2	121-0299	8	Screw-HHF	13	121-0240	1	Connecting Rod ASM
4	121-0227	1	Cover-Crankcase	14	121-0239	1	Set-Ring, Piston
5	121-0223	1	Sump Plug ASM	15	121-0236	1	Piston
6	121-0265	1	Governor Gear ASM	16	121-0237	1	Pin-Piston
7	121-0315	1	Bearing-Main	17	121-0313	2	Clip-Pin, Piston
8	121-0242	1	Camshaft ASM	18	121-0352	1	Complete Governor Kit
9	121-0356	1	Seal And Gasket Kit	19	120-4256	1	Pin-Hair
9:1		1	Seal-Oil ●	20	121-0311	1	Washer-Plain
9:2		1	Seal-Oil ●	21	121-0263	1	Shaft-Governor
9:3	121-0228	1	Gasket-Cover, Crankcase	22	121-0439	1	Crankcase
9:4	121-0232	1	Gasket-Head, Cylinder	23	121-0222	1	Screw-HHF
9:5	121-0234	1	Gasket-Cover, Valve	24	121-0310	1	Washer-Plain
9:6		1	Gasket-Exhaust ●	25	121-0278	1	Clamp
9:7		1	Gasket-Carburetor ●	26	121-0118	1	Screw-HHF
9:8		1	Gasket-Carburetor ●	27	121-0341	1	Drain Plug Kit
11	121-0314	2	Pin-Dowel	28	121-0325	1	Grommet-Rubber

● Not serviced separately

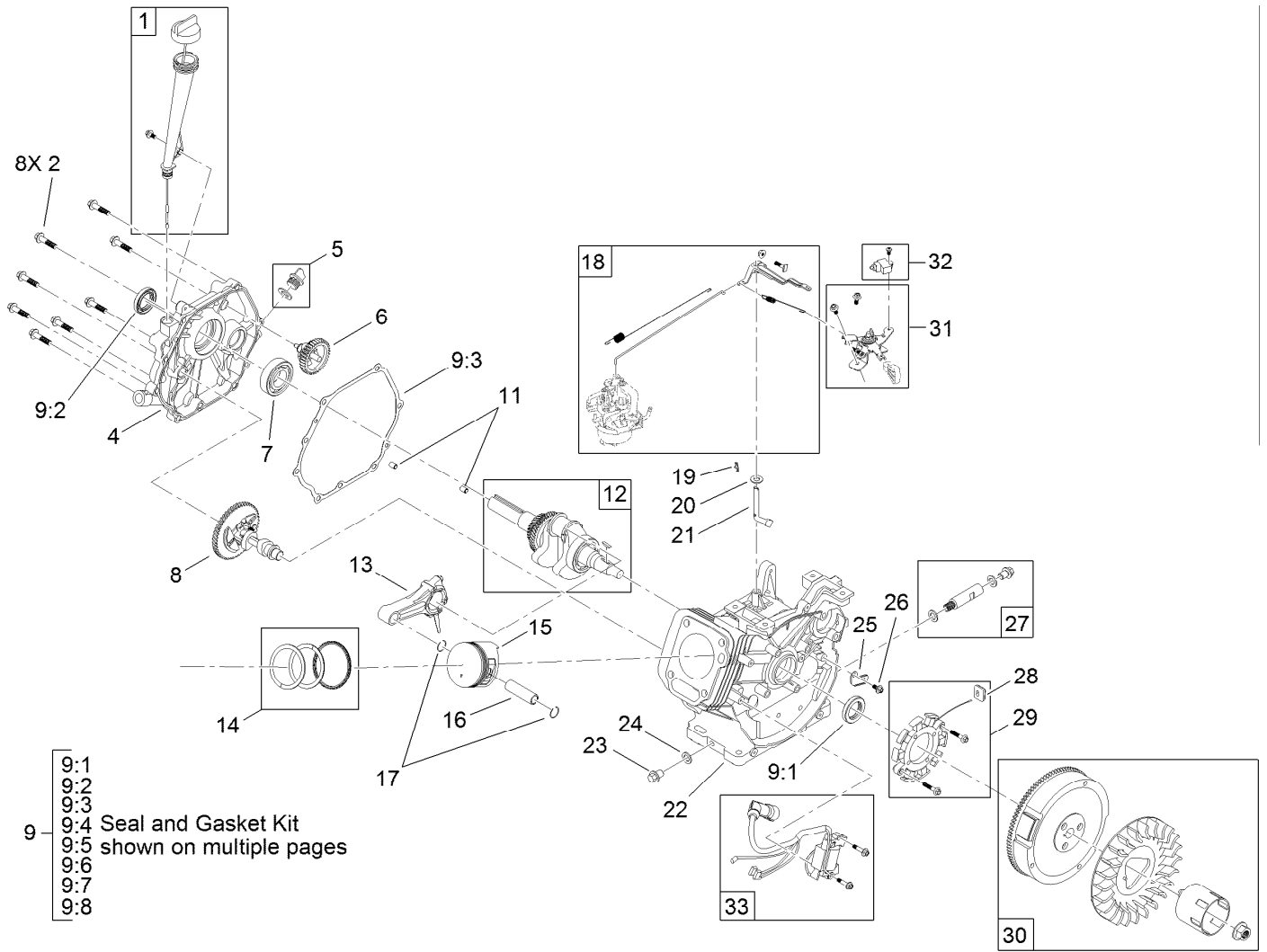

Crankcase Engine Assembly (continued)

Ref.	Part Number	Qty.	Description	Ref.	Part Number	Qty.	Description
29	121-0362	1	Stator Kit	32	121-4106	1	Kill Switch Kit
30	121-0354	1	Fan And Flywheel Kit	33	121-0334	1	Ignition Module Kit
31	121-4107	1	Throttle Control Kit				

● Not serviced separately

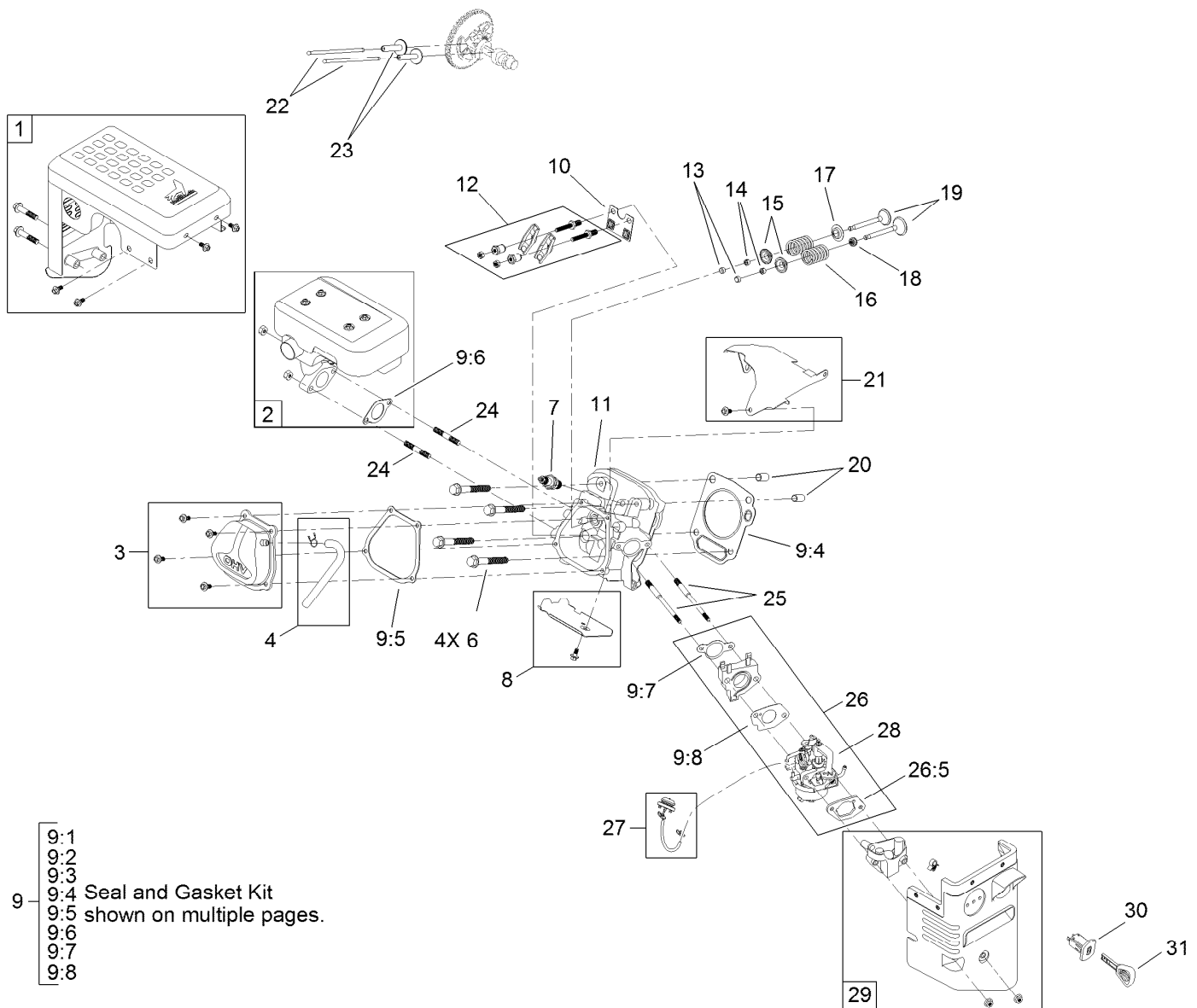

- 9:1
- 9:2
- 9:3
- 9:4 Seal and Gasket Kit
- 9:5 shown on multiple pages.
- 9:6
- 9:7
- 9:8

Muffler, Cylinder Head and Carburetor Engine Assembly

Ref.	Part Number	Qty.	Description	Ref.	Part Number	Qty.	Description
1	121-4101	1	Muffler Shield Kit	11	121-0230	1	Head-Cylinder
2	121-4100	1	Muffer Kit	12	121-0245	1	Rocker Arm ASM
3	121-0343	1	Valve Cover Kit	13	121-0244	2	Rotator-Valve
4	121-0340	1	Breather Tube Kit	14	120-4307	2	Keeper-Valve
6	121-0302	4	Screw-HHF	15	120-4306	2	Retainer-Spring, Valve
7	119-1901	1	Spark Plug	16	120-4305	2	Spring-Valve
8	121-0348	1	Lower Heat Shroud Kit	17	120-4303	1	Seat-Spring, Valve
9	121-0356	1	Seal And Gasket Kit	18	120-4304	1	Seal-Stem, Valve
9:1		1	Seal-Oil ●	19	121-0328	1	Valve Kit
9:2		1	Seal-Oil ●	20	120-4200	2	Pin-Dowel
9:3	121-0228	1	Gasket-Cover, Crankcase	21	121-4102	1	Upper Heat Shroud Kit
9:4	121-0232	1	Gasket-Head, Cylinder	22	121-0246	2	Rod-Push
9:5	121-0234	1	Gasket-Cover, Valve	23	120-4298	2	Lifter-Valve
9:6		1	Gasket-Exhaust ●	24	121-0304	2	Stud-Mount, Muffer
9:7		1	Gasket-Carburetor ●	25	121-0303	2	Stud-Mount, Carburetor
9:8		1	Gasket-Carburetor ●	26	121-0345	1	Complete Carb Service Kit
10	121-0247	1	Plate-Guide, Push Rod	26:5	121-0254	1	Gasket-Coated, Rubber

● Not serviced separately

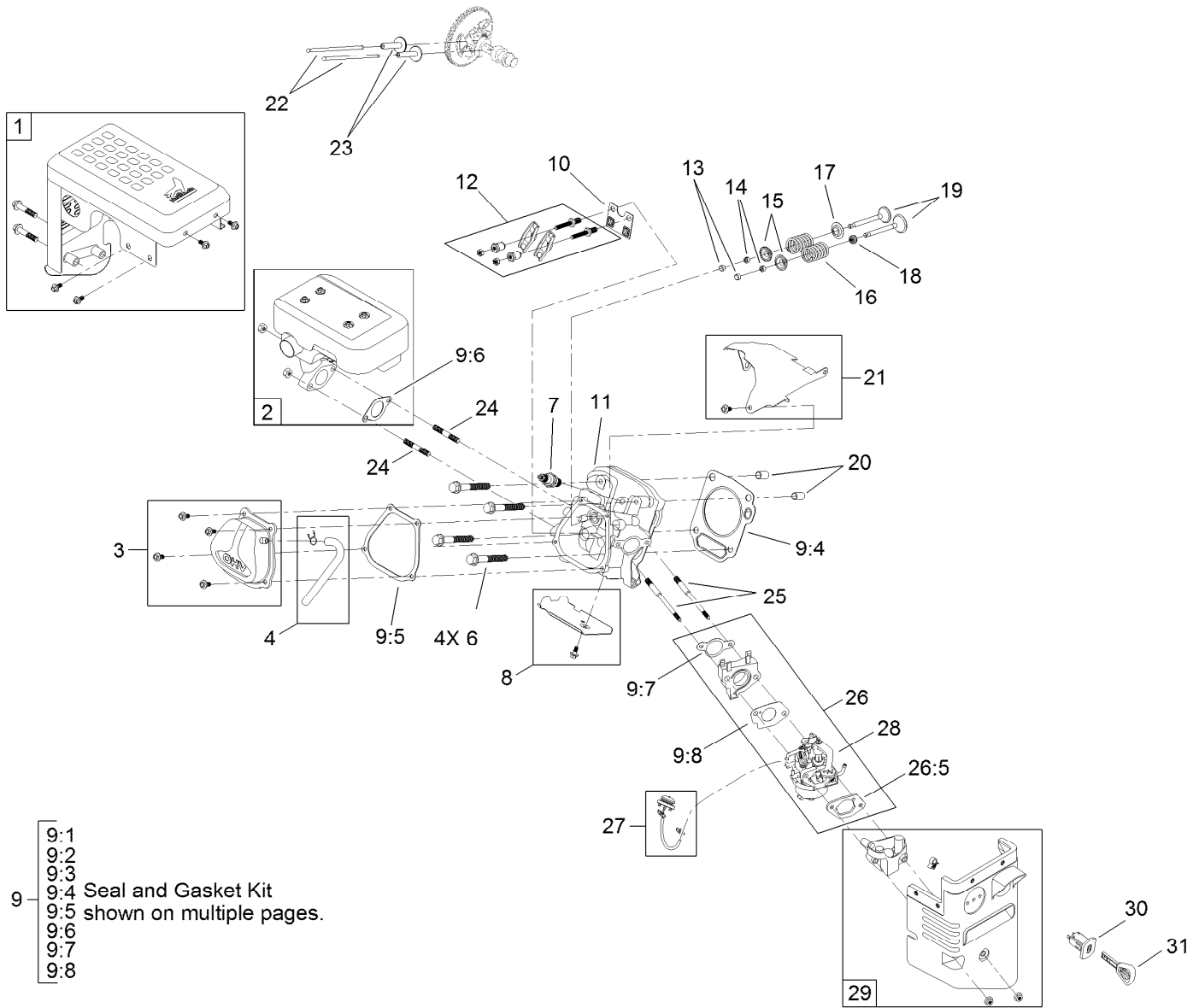

Muffler, Cylinder Head and Carburetor Engine Assembly (continued)

Ref.	Part Number	Qty.	Description	Ref.	Part Number	Qty.	Description
27	121-0344	1	Primer Kit	29	121-0355	1	Heater Box Kit
28	121-0360	1	Carburetor Internal Repair Kit	30	121-0283	1	Switch-Key
				31	117-7728	1	Key

● Not serviced separately

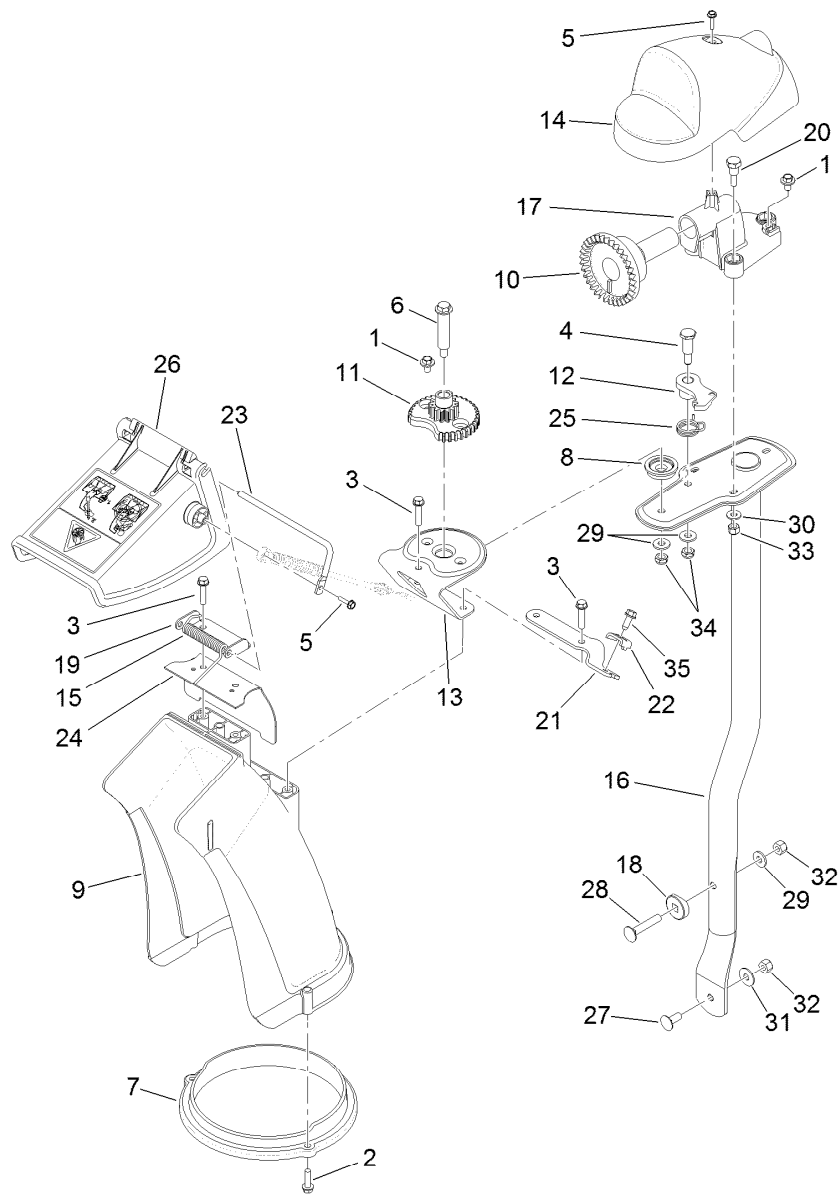

Chute Assembly

Ref.	Part Number	Qty.	Description	Ref.	Part Number	Qty.	Description
1	46-6810	3	Screw And Washer ASM	19	106-7266	1	Bracket-Deflector
2	46-8091	3	Screw-HWH	20	106-7276	3	Screw-Shoulder
3	46-8092	5	Screw-Plastite	21	106-7296	1	Bracket-Cable, Clamp
4	63-2650	1	Screw-Shoulder	22	106-7297	1	Clamp-Cable
5	98-1375	2	Screw-HWH	23	107-1021	1	Rod-Deflector
6	100-9880	1	Bolt-Shoulder	24	108-5052	1	Seal-Chute
7	105-9991	1	Ring-Chute	25	108-7315	1	Spring-Torsion
8	106-4422	1	Spacer-Chute	26	112-6629	1	Deflector-Chute, Ce
9	106-4440	1	Chute-Discharge	27	3230-23	1	Screw-CARR
10	106-4471	1	Gear-Face	28	3230-5	1	Screw-CARR
11	106-4472	1	Gear-Chute	29	3256-2	3	Washer-Flat
12	106-4476	1	Latch-Chute	30	3256-22	3	Washer-Flat
13	106-4582-03	1	Bracket-Support, Chute	31	3290-456	1	Washer-Belleville
14	106-4585	1	Cover-Gear, Chute	32	3296-29	2	Nut-Lock, NI
15	106-4594	1	Spring-Torsion	33	3296-42	3	Nut-Lock, NI
16	106-7253-03	1	Tube-Support	34	3296-47	2	Nut-Lock, NI
17	106-7257	1	Mount-Gear, Face	35	32144-10	1	Screw-HWH
18	106-7260	1	Washer-Curved				

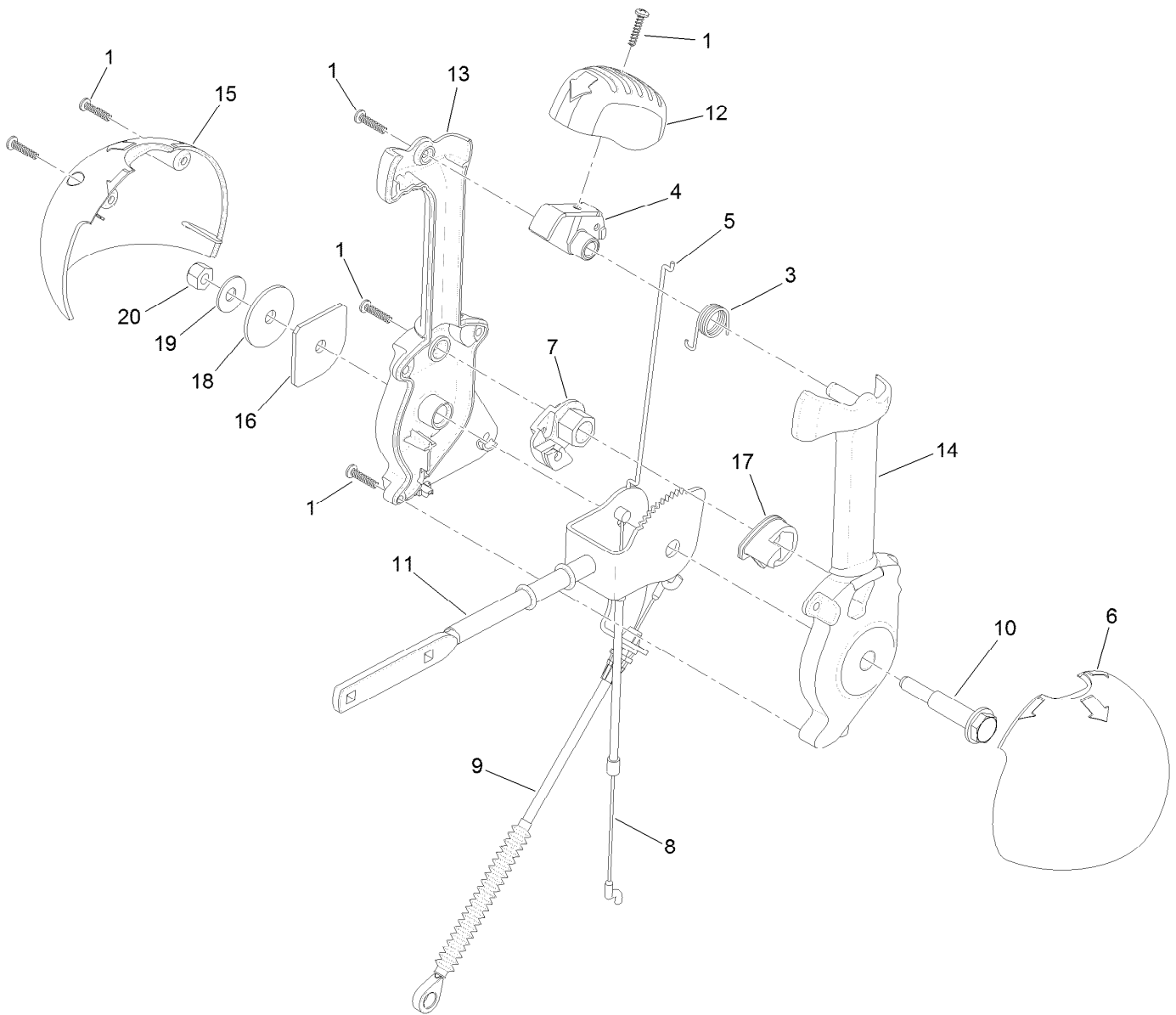

Lever Chute Control Assembly

<i>Ref.</i>	<i>Part Number</i>	<i>Qty.</i>	<i>Description</i>	<i>Ref.</i>	<i>Part Number</i>	<i>Qty.</i>	<i>Description</i>
1	94-4496	6	Screw-PPH	12	106-7280	1	Cap-Lever
3	105-9982	1	Spring-Torsion	13	106-7281	1	Lever-Chute Control, RH
4	105-9984	1	Trigger-Latch	14	106-7282	1	Lever-Chute Control, LH
5	105-9985	1	Link-Latch	15	106-7292	1	Cover-Chute Lever, RH
6	105-9986	1	Cover-Chute Lever, LH	16	106-7295	1	Plate-Friction
7	105-9988	1	Lever-Cable, Deflector	17	106-7310	1	Pawl-Latch
8	125-1113	1	Cable-Release, Chute	18	107-3002	1	Washer-Nylon
9	105-9990	1	Cable-Control, Deflector	19	3290-456	1	Washer-Belleville
10	105-9995	1	Screw-Shoulder	20	3296-29	1	Nut-Lock, NI
11	106-4479	1	Rod-Control, Chute				

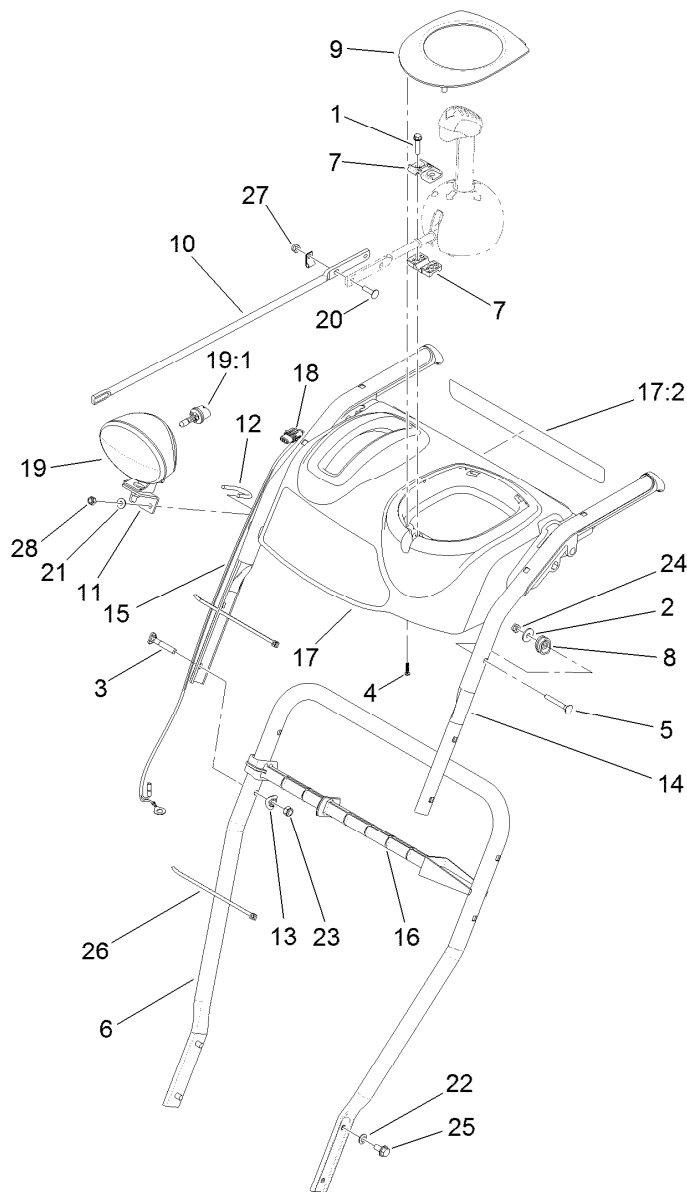

Lower Handle and Headlamp Assembly

<i>Ref.</i>	<i>Part Number</i>	<i>Qty.</i>	<i>Description</i>	<i>Ref.</i>	<i>Part Number</i>	<i>Qty.</i>	<i>Description</i>
1	46-8092	2	Screw-Plastite	16	110-3408	1	Stick-Cleanout
2	87-6630	2	Washer-Plain	17	112-6633	1	Panel-Control
3	92-2260	4	Screw-Handle	17:2	112-6627	1	Decal-Back, Control Panel
4	94-4496	2	Screw-PPH	18	120-3062	1	Harness-Wire, Headlight
5	95-4453	2	Screw	19	120-3074	1	Headlamp ASM
6	105-9981-03	1	Handle-Lower	19:1	120-3075	1	Lamp-12 Volt
7	105-9987	2	Support-Rod	20	3229-30	2	Screw-CARR
8	106-4509	2	Clamp-Cable	21	3256-1	2	Washer-Flat
9	106-4586	1	Cover-Panel, Control	22	3290-475	4	Washer-Belleville
10	106-7283	1	Rod-Chute, Front	23	3296-72	4	Nut-Lock, NI
11	107-1020-03	1	Bracket-Light	24	3296-73	2	Nut-Lock, NI
12	107-3024	1	Clamp	25	32144-14	4	Screw-HWHTF
13	107-3844	4	Washer	26	614249	2	Tie-Cable
14	108-0037-03	1	Handle-Upper, LH	27	3296-73	2	Nut-Lock, NI
15	108-0038-03	1	Handle-Upper, RH	28	3296-73	2	Nut-Lock, NI

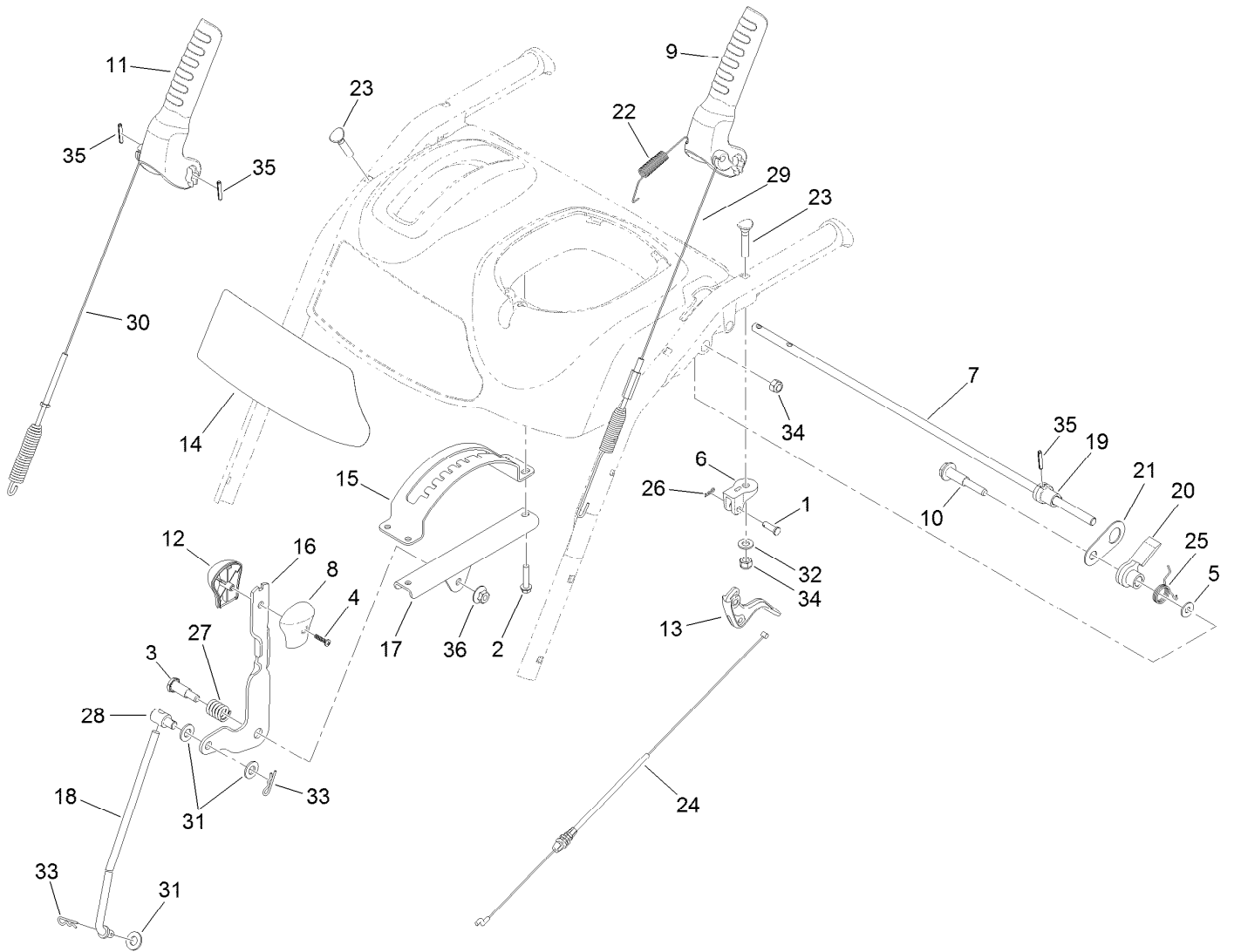

Handle and Control Assembly

Ref.	Part Number	Qty.	Description	Ref.	Part Number	Qty.	Description
1	1-808265	2	Pin-Clevis	19	107-1043	1	Cam-Lockout
2	46-8092	4	Screw-Plastite	20	108-0023	1	Latch-Lockout
3	63-2650	1	Screw-Shoulder	21	107-3000	1	Link-Lockout
4	94-4496	1	Screw-PPH	22	107-3001	1	Spring-Tension
5	98-3499	1	Washer-Flat	23	107-3018	4	Screw-Handle
6	105-9980	2	Mount-Clutch, Lever	24	107-8896	2	Cable-Clutch
7	105-9996	1	Rod-Lockout	25	108-0024	1	Spring-Torsion
8	105-9999	1	Knob-Shift, LH	26	108-2992	2	Pin-Hair
9	106-4410	1	Lever-Traction	27	108-7313	1	Spring-Compression
10	106-4412	1	Screw-Shoulder	28	110-3446	1	Trunnion-Rod
11	106-4413	1	Lever-Auger	29	120-0132	1	Cable-Traction
12	106-4423	1	Knob-Shift, RH	30	120-3086	1	Cable-Auger
13	106-4505	2	Lever-Clutch	31	3256-24	3	Washer-Flat
14	121-6643	1	Decal-Control Panel	32	3256-70	4	Washer-Flat
15	106-7277-03	1	Guide-Selector, Speed	33	3290-307	2	Pin-Hair
16	106-7278-03	1	Selector-Speed	34	3296-72	5	Nut-Lock, NI
17	106-7279-03	1	Mount-Selector, Speed	35	32121-125	3	Pin-Spring
18	107-1005	1	Rod-Shift	36	32128-13	1	Nut-HHF

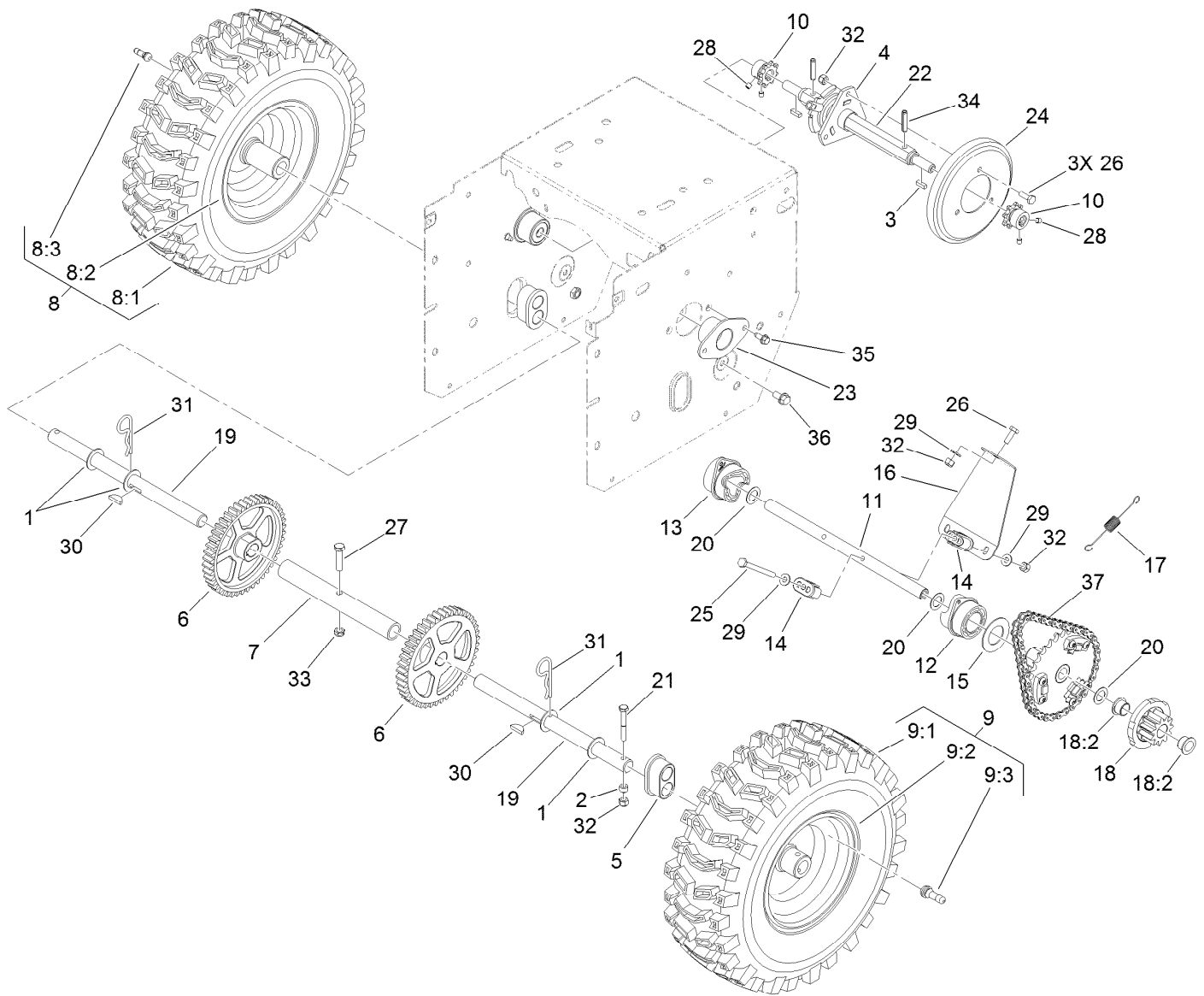

Wheel Clutch Assembly

Ref.	Part Number	Qty.	Description	Ref.	Part Number	Qty.	Description
1	3-8664	4	Washer-Thrust	13	107-8888	1	Collar-Shift, RH
2	55-9370	2	Spacer-Blade, Rotor	14	107-8889	4	Guide-Collar
3	94-8850	2	Key-Square	15	107-8891	2	Washer-Thrust
4	106-4434	1	Trunnion-Hex	16	107-8892-03	1	Brace-Collar, Shift
5	106-4558	2	Bearing-Axle	17	107-8893	2	Spring-Extension
6	106-4572	2	Gear-Axle, 44 Tooth	18	107-8894	2	11T Gear ASM
7	106-7259	1	Tube-Axle	18:2	108-2973	2	Bushing-Flange
8		1	RH Wheel And Tire ASM ●	19	107-8898	2	Shaft-Axle
8:1	107-3042	1	Tire	20	108-0015	4	Washer-Flat
8:2	107-3043	1	Rim-Tire	21	108-2975	2	Screw-HH
8:3	232-27	1	Stem-Valve	22	108-7314	1	Shaft-Hex
9		1	LH Wheel And Tire ASM ●	23	108-7319	2	Retainer-Bearing
9:1	107-3042	1	Tire	24	119-1567	1	Wheel-Friction
9:2	107-3043	1	Rim-Tire	25	321-23	2	Screw-HH
9:3	232-27	1	Stem-Valve	26	321-4	4	Screw-HH
10	106-7317	2	Sprocket-8 Tooth	27	322-17	1	Screw-HH
11	107-8883	1	Shaft-Intermediate	28	3245-32	4	Screw-HSH
12	107-8887	1	Collar-Shift, LH	29	3256-22	5	Washer-Flat

● Not serviced separately

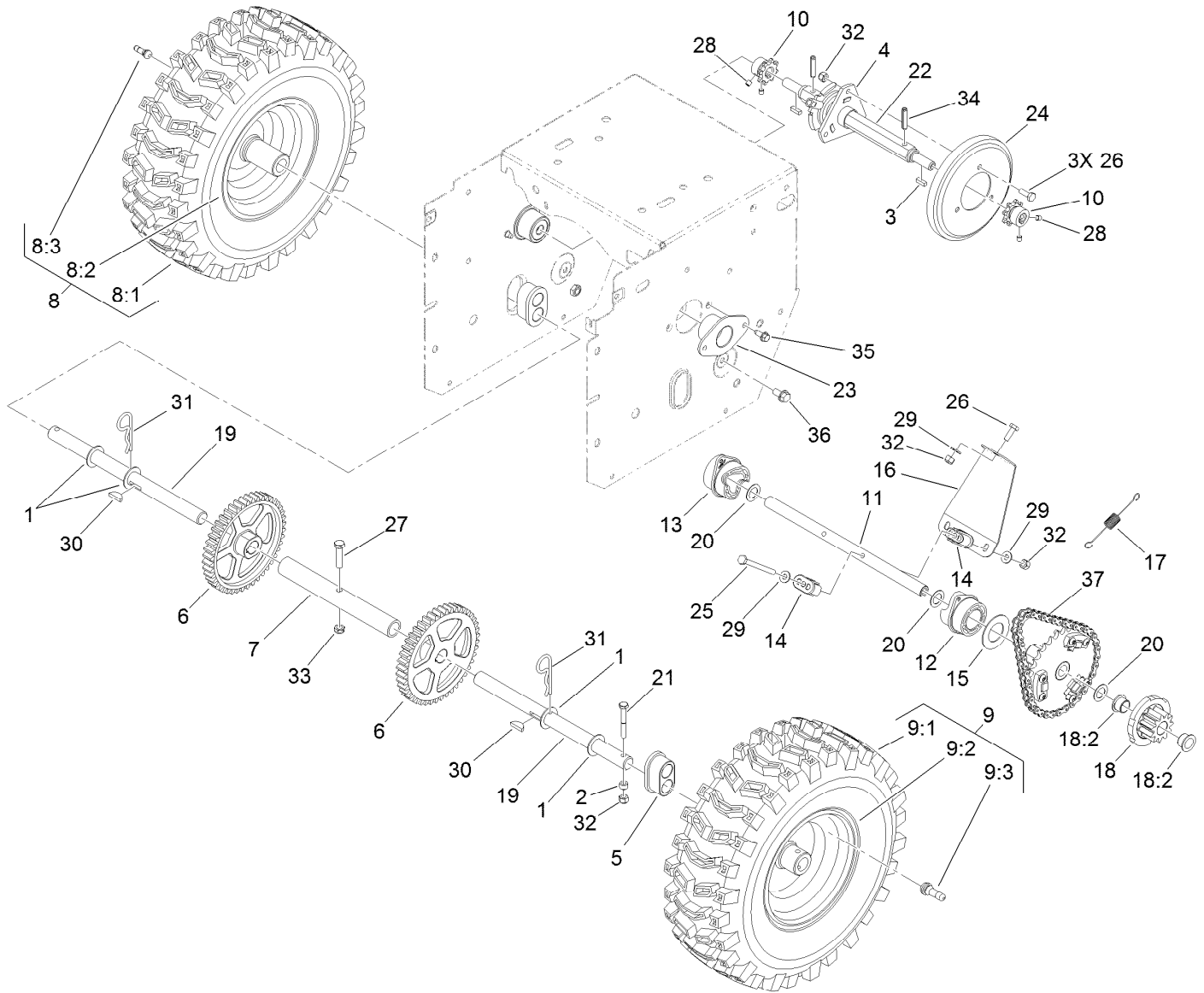

Wheel Clutch Assembly (continued)

Ref.	Part Number	Qty.	Description	Ref.	Part Number	Qty.	Description
30	3257-7	2	Key-Woodruff	35	32144-10	4	Screw-HWH
31	3290-343	2	Pin-Hair	36	32144-14	2	Screw-HWHTF
32	3296-42	8	Nut-Lock, NI	37	108-0016	2	Chain-Roller
33	3296-47	1	Nut-Lock, NI	37	2710-6	2	Link-Connecting
34	32121-9	2	Pin-Roll, Slotted				

● Not serviced separately

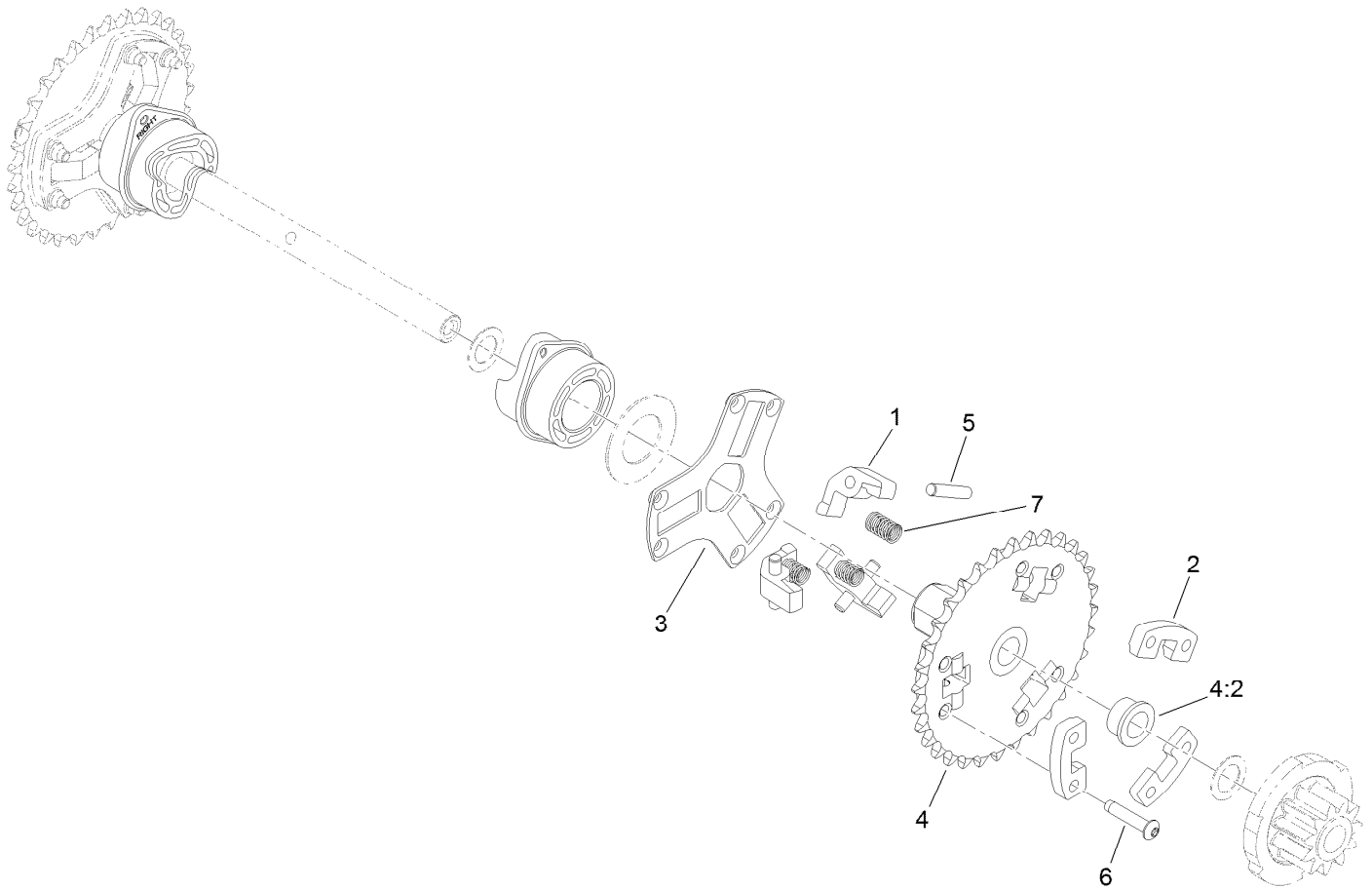

Wheel Clutch Sprocket Assembly

<i>Ref.</i>	<i>Part Number</i>	<i>Qty.</i>	<i>Description</i>
1	107-8879	6	Pawl-Clutch
2	107-8880	6	Support-Pawl
3	107-8886	2	Retainer-Pin, Pawl
4	107-8895	2	32T Sprocket ASM
4:2	108-2973	2	Bushing-Flange
5	107-8899	6	Pin-Dowel
6	108-0035	12	Screw-Torx Button Head
7	107-8885	6	Spring-Compression

Attachments and Accessories

For 38822 Power Max Heavy Duty 928 OXE Snowthrower

Product Name	Model/Part
Tire Chain Kit	107-3813
Snow Cab	107-3814
Weight Kit	107-3815
28 Inch Drift Breaker	107-3817
Non-Marking Skid Kit	38211
Toro 2-Stage Cover	490-7466
Plain 2-Stage Cover	490-7467

Notes:

Notes:



Count on it.