



Count on it.

Parts Catalog

MH-400SH2 Material Handler

Model No. 44931—Serial No. 313000301 and Up



Ordering Replacement Parts

To order replacement parts, please supply the part number, the quantity, and the description of each part desired.

Understanding Reference Numbers

Each identified part in an illustration has a reference number. The reference number for a part also appears in the parts list, along with other information about the part.

This catalog uses two special reference number formats, one to indicate parts in a service assembly and another to indicate the quantity of a given part in an illustration.

Service Assembly Reference Numbers

Parts in service assemblies have reference numbers in the form a:b. The a represents the reference number of the entire service assembly and the b represents a sequential number unique to each part within the service assembly.

For example, a wheel assembly might be identified by reference number 6, the tire by 6:1, the valve by 6:2, and the wheel by 6:3. When you order the assembly identified by reference number 6, you receive all parts identified by reference numbers 6:1, 6:2, and 6:3. However, you may also order any part individually. Reference numbers of this type appear in illustration and in parts lists.

Reference Numbers Indicating Quantity

In an illustration, if a reference number indicates more than one part, the reference number has the form nX y. The n represents the quantity of the part, the X is the multiplication symbol, and the y represents the reference number.

For example, in an illustration, the reference number 2X 37 means that two of the parts identified by reference number 37 are indicated.

List of Abbreviations

AR: as required	HLH: hex lag head	PTO: power-take-off
ASM: assembly	HOC: height-of-cut	RH: right hand
BBC: blade brake control	HSBH: hex socket button head	ROPS: roll-over protection system
BHTF: button head thread forming	HSFH: hex socket flat head	RRB: rear roller brush
CARR: carriage	HSH: hex socket head	SFH: slotted fillister head
CCW: counter clockwise	HWH: hex washer head	SHH: slotted hex head
CW: clockwise	HWHTF: hex washer head thread forming	SHWH: slotted hex washer head
DEG: degrees	HYD: hydraulic	SPH: slotted pan head
DPA: Dual Point Adjustment	LH: left hand	SQH: square head
ECM: electronic control module	LP: Liquefied Petroleum Gas	SRH: slotted round head
EXT: external	LPG: Liquefied Petroleum Gas	STD: standard
FH: flat head	NI: nylon insert	TAP: self tapping
GA: gauge	NPTF: national pipe thread fine	TTH: torx truss head
HD: heavy-duty	PFH: phillips flat head	
HF: hex flange	PPH: phillips pan head	
HH: hex head	PPHTF: phillips pan head thread forming	
HHF: hex head flange	PRH: phillips round head	
HHFTF: hex head flange thread forming	PTH: phillips truss head	
HJ: hex jam		

Contents

Box Frame Assembly	4
Box Frame Decal Assembly No. 120-0890	5
Attachment Clamp Assembly No. T36015800	6
Guard Assembly	7
Hitch Assembly	8
Belt and Skirting Assembly	9
Skirting Assembly	10
Conveyor Assembly	11
Chain Drive Assembly	12
Wheel Assembly	13
RH Shaft Assembly No. 120-9401	14
LH Brake Assembly No. 120-9437	15
Hub Assembly No. 120-9404	16
LH Shaft Assembly No. 120-9402	17
RH Brake Assembly No. 120-9436	18
Hydraulic Valve and Manifold Assembly	19
Hydraulic Valve Assembly No. 120-0850	21
Hydraulic Hose and Clamp Assembly	22
Hydraulic Cylinder and Junction Box Manifold Assembly	23
Hydraulic Hose Assembly	24
Hydraulic Guard Box Assembly	25
Hydraulic Motor Assembly No. T0000-5303	26
Electrical Assembly	27
Brake Assembly	28

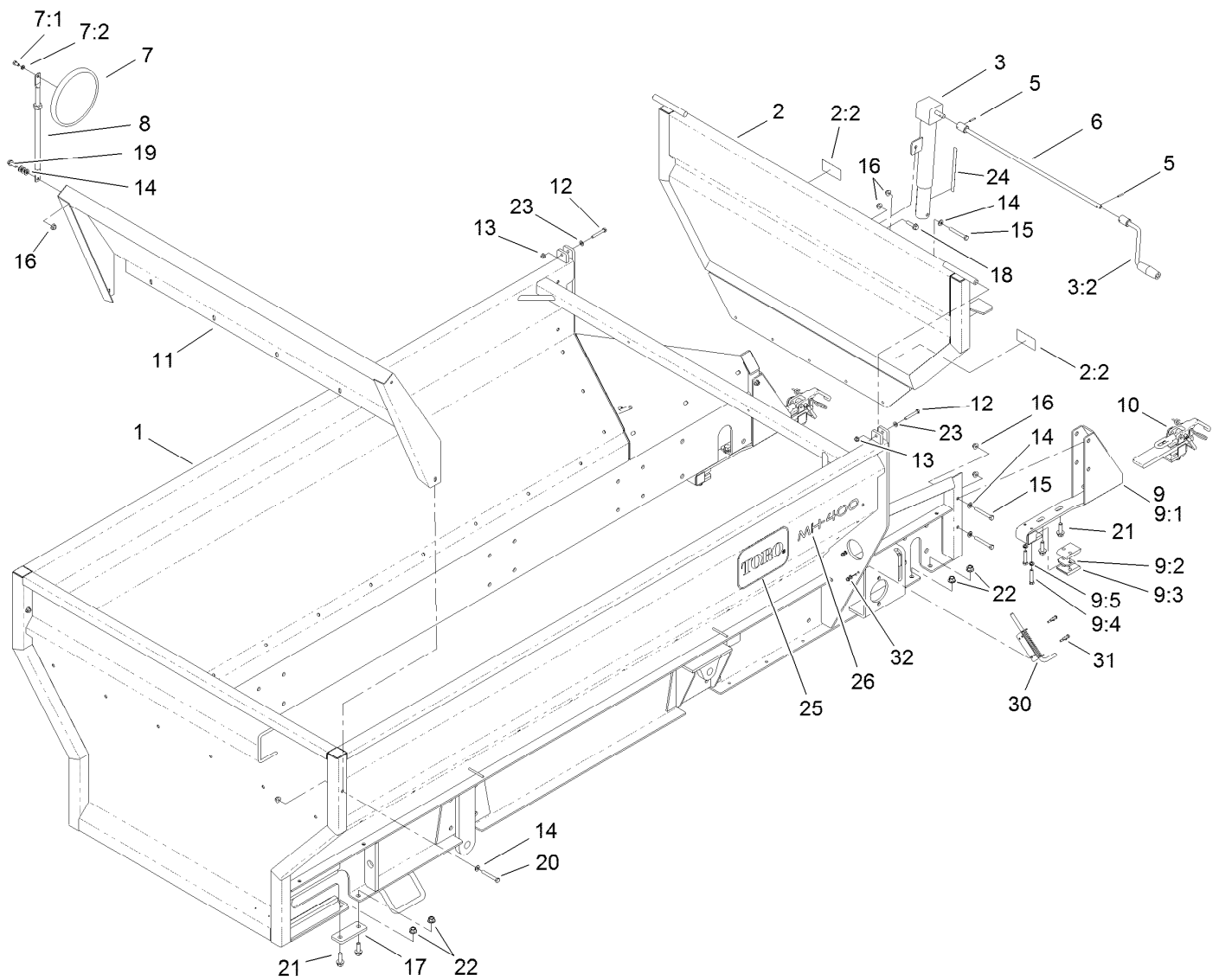

Box Frame Assembly

Ref.	Part Number	Qty.	Description	Ref.	Part Number	Qty.	Description
1	120-0890	1	Box Frame ASM	12	322-11	2	Screw-HH
2	120-0891	1	Tailgate ASM	13	104-8300	2	Nut-Flange, NI
2:2	119-6838	2	Decal-Warning, Conveyor	14	3256-24	10	Washer-Flat
3	T36031200	1	Jack-Tailgate	15	323-14	5	Screw-HH
3:2	T36031210	1	Handle-Crank	16	104-8301	14	Nut-Flange, NI
5	32121-45	2	Pin-Spring	17	T36011650	2	Bar-Bridge
6	T36011220-01	1	Crank-Jack	18	114-4681	1	Screw-HHF
7	92-2678	1	Mirror-Convex	19	3234-42	6	Screw-HHF
7:1	322-2	1	Screw-HH	20	323-13	2	Screw-HH
7:2	3253-4	1	Washer-Lock	21	100-6116	8	Screw-HHF
8	T36011560	1	Arm-Mirror	22	99-5107	8	Nut-Lock
9	T36015790	2	Attachment Bracket ASM	23	3256-23	2	Washer-Flat
9:1	119-6872-01	1	Bracket-Attachment	24	119-6869	1	Decal-Tailgate Adjustment
9:2	T01-13489B	1	Tab-Spacer	25	66-6140	3	Decal
9:3	T36015200	2	Bar-Bearing	26	119-6802	3	Decal
9:4	323-10	2	Screw-HH	30	T62021030	2	Latch-Spring
9:5	3253-21	2	Washer-Lock	31	321-6	8	Screw-HH
10	T36015800	2	Attachment Clamp ASM	32	104-7201	8	Nut-HF
11	T36011550-01	1	Panel-Sloped				

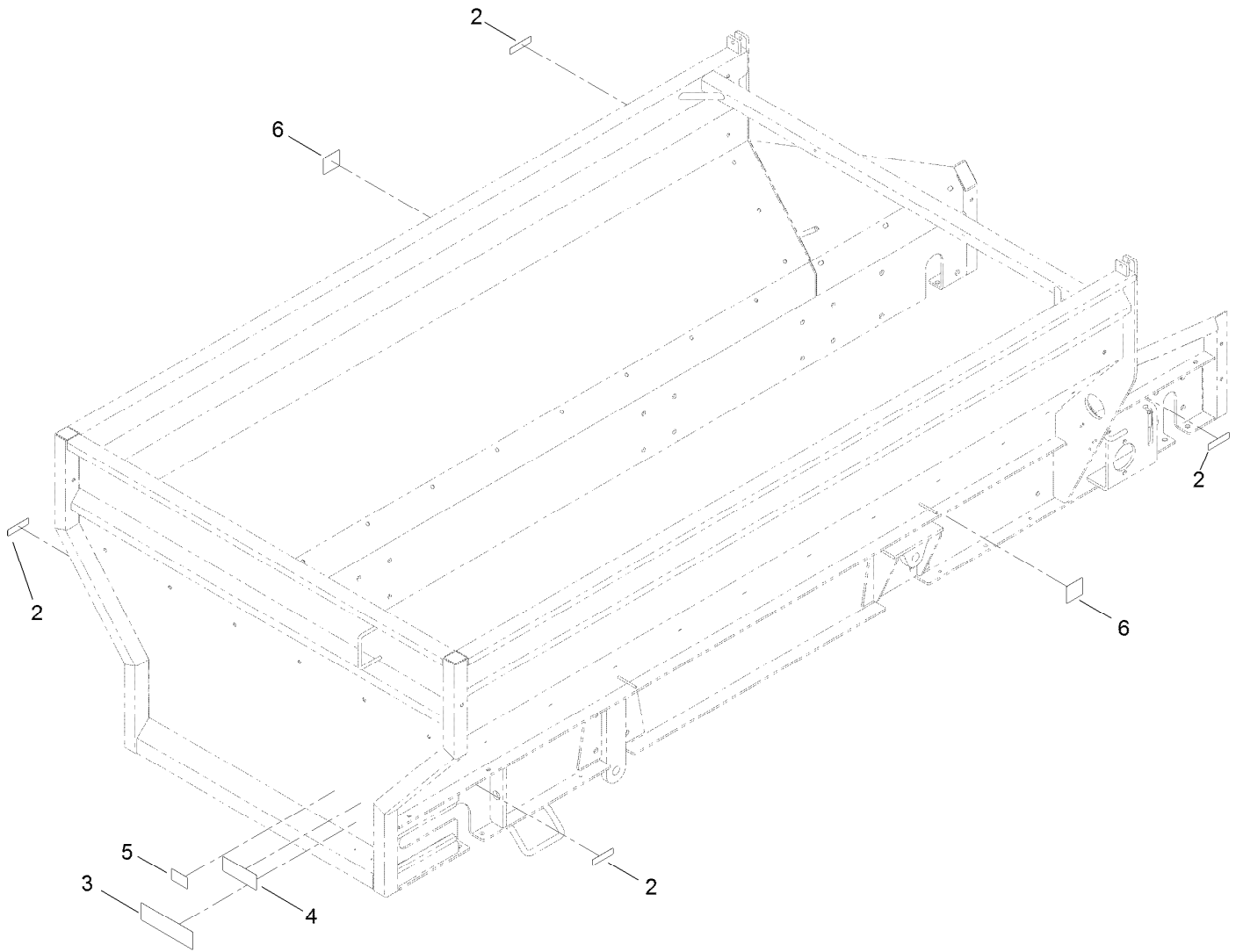

Box Frame Decal Assembly No. 120-0890

<i>Ref.</i>	<i>Part Number</i>	<i>Qty.</i>	<i>Description</i>
2	119-0217	4	Decal-Danger
3	119-6806	1	Decal-Danger
4	119-6812	1	Decal-Warning, Tipping Hazard
5	119-6833	1	Decal-Max Load
6	93-9899	2	Decal-Warning

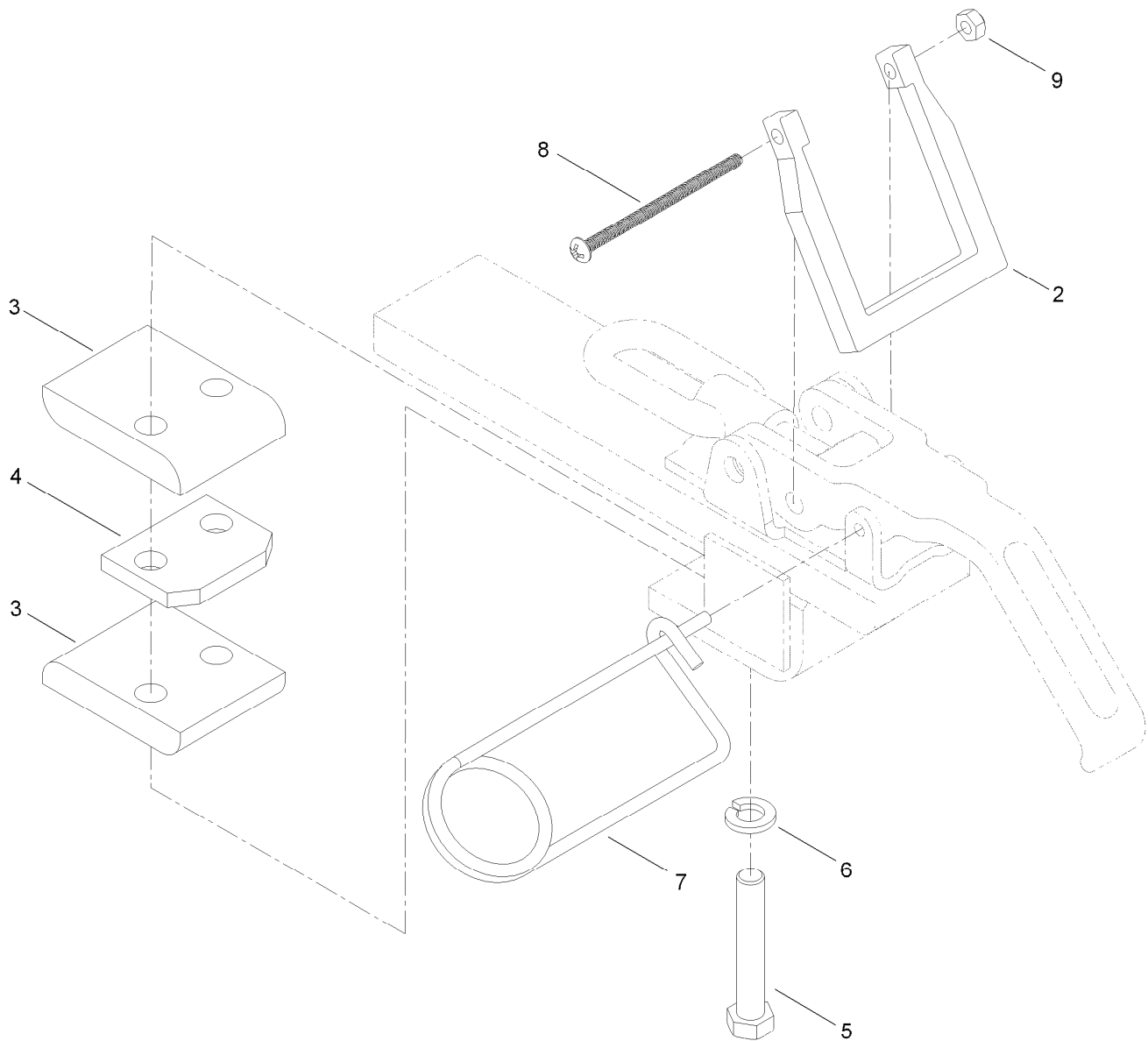

Attachment Clamp Assembly No. T36015800

<i>Ref.</i>	<i>Part Number</i>	<i>Qty.</i>	<i>Description</i>
2	T36015794	1	Lock-Attachment Clamp
3	T36015200	2	Bar-Bearing
4	T01-13489B	1	Tab-Spacer
5	323-11	2	Screw-HH
6	3253-21	2	Washer-Lock
7	T0000-3247	1	Pin-Lock
8	120-0884	1	Screw-PRH
9	3296-2	1	Nut-Lock, NI

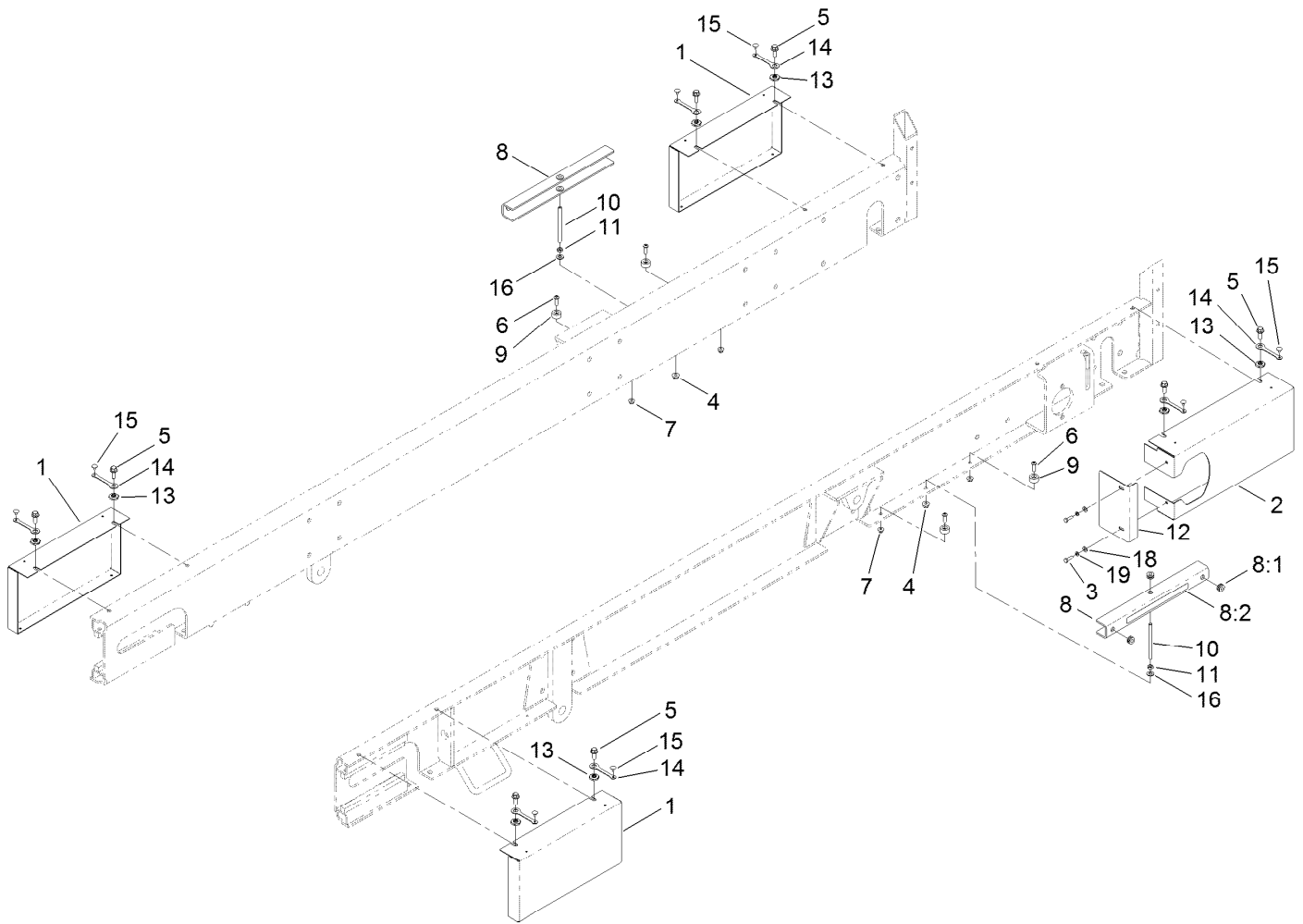

Guard Assembly

Ref.	Part Number	Qty.	Description
1	T36011630-03	3	Guard-Idler
2	T36011640-03	1	Guard-Drive
3	321-5	2	Screw-HH
4	104-8301	2	Nut-Flange, NI
5	3234-42	8	Screw-HHF
6	3274-104	4	Screw-HSBH
7	104-8300	4	Nut-Flange, NI
8	T36011580	2	Lift Cylinder Stop ASM
8:1	92-5972	4	Grommet-Rubber
8:2	93-9852	1	Decal-Warning

Ref.	Part Number	Qty.	Description
9	T0001-3570	4	Spacer-Stop, Lift Cylinder
10	T36011590	2	Pin-Lift Cylinder Stop
11	3218-3	2	Nut-Jam
12	T0000-5529-03	1	Guard-Motor, Drive
13	117-8347	8	Nut-Shoulder
14	117-8339	8	Lanyard-3 Inch
15	146489	8	Rivet
16	3256-24	2	Washer-Flat
18	3256-22	2	Washer-Flat
19	3253-3	2	Washer-Lock

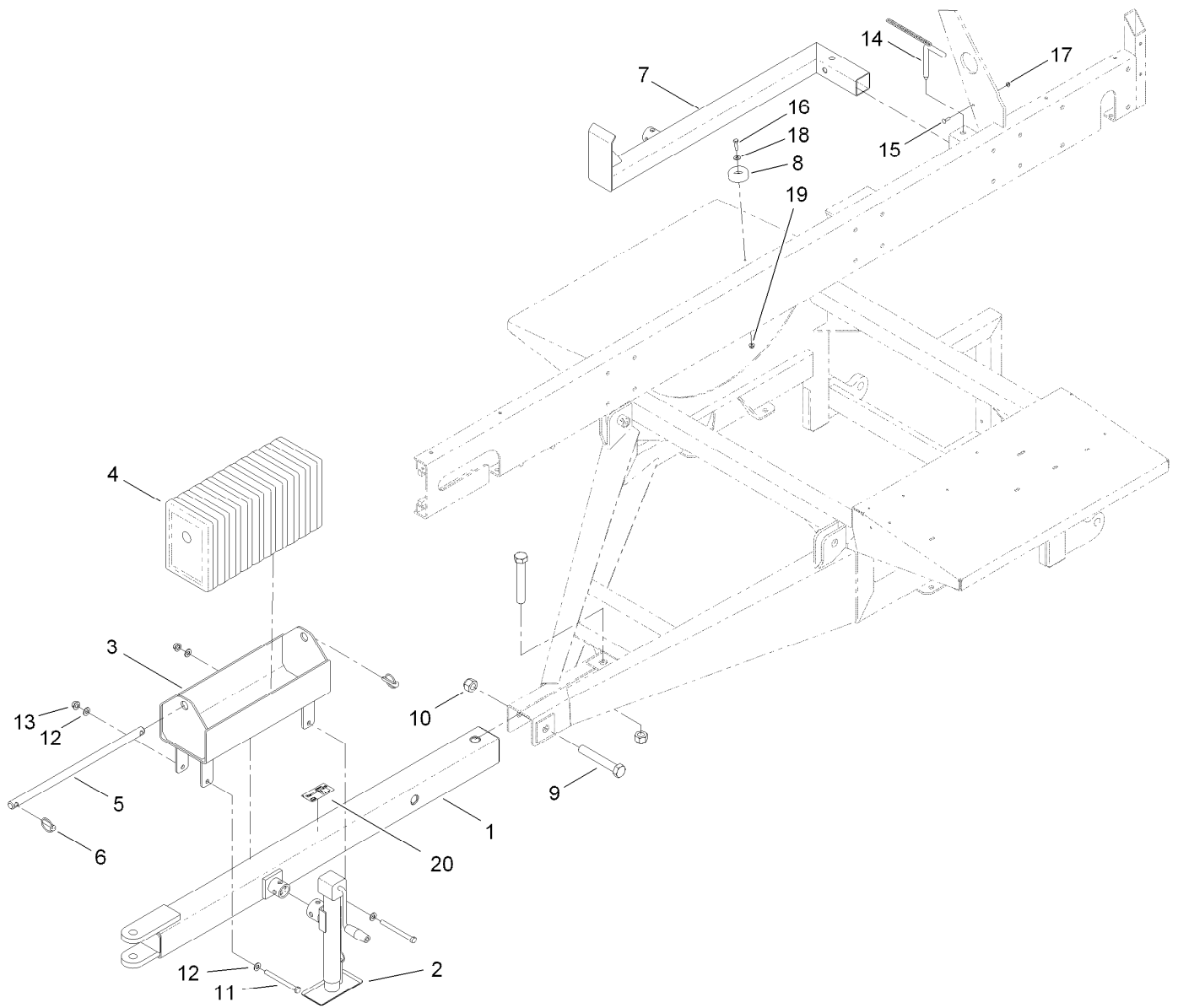

Hitch Assembly

<i>Ref.</i>	<i>Part Number</i>	<i>Qty.</i>	<i>Description</i>	<i>Ref.</i>	<i>Part Number</i>	<i>Qty.</i>	<i>Description</i>
1	T36012112-01	1	Tube-Hitch	11	325-22	2	Screw-HH
2	T0000-3423	1	Jack-Sidewind	12	3256-26	4	Washer-Flat
3	T36028000-01	1	Box-Weight	13	99-5107	2	Nut-Lock
4	119-6860-01	10	Casting-Counterweight	14	T36011195	1	Pin
5	T36028010-01	1	Shaft-Weight Box	15	3229-2	1	Screw-CARR
6	283-71	2	Pin-Lynch	16	322-6	1	Screw-HH
7	T36011190-01	1	Leg-Jack	17	104-7201	1	Nut-HF
8	108-1605	1	Bumper-Recess	18	3256-3	1	Washer-Flat
9	120-0887	2	Screw-HH	19	104-8300	1	Nut-Flange, NI
10	120-0888	2	Nut-HH	20	119-6836	1	Decal-Weight Case

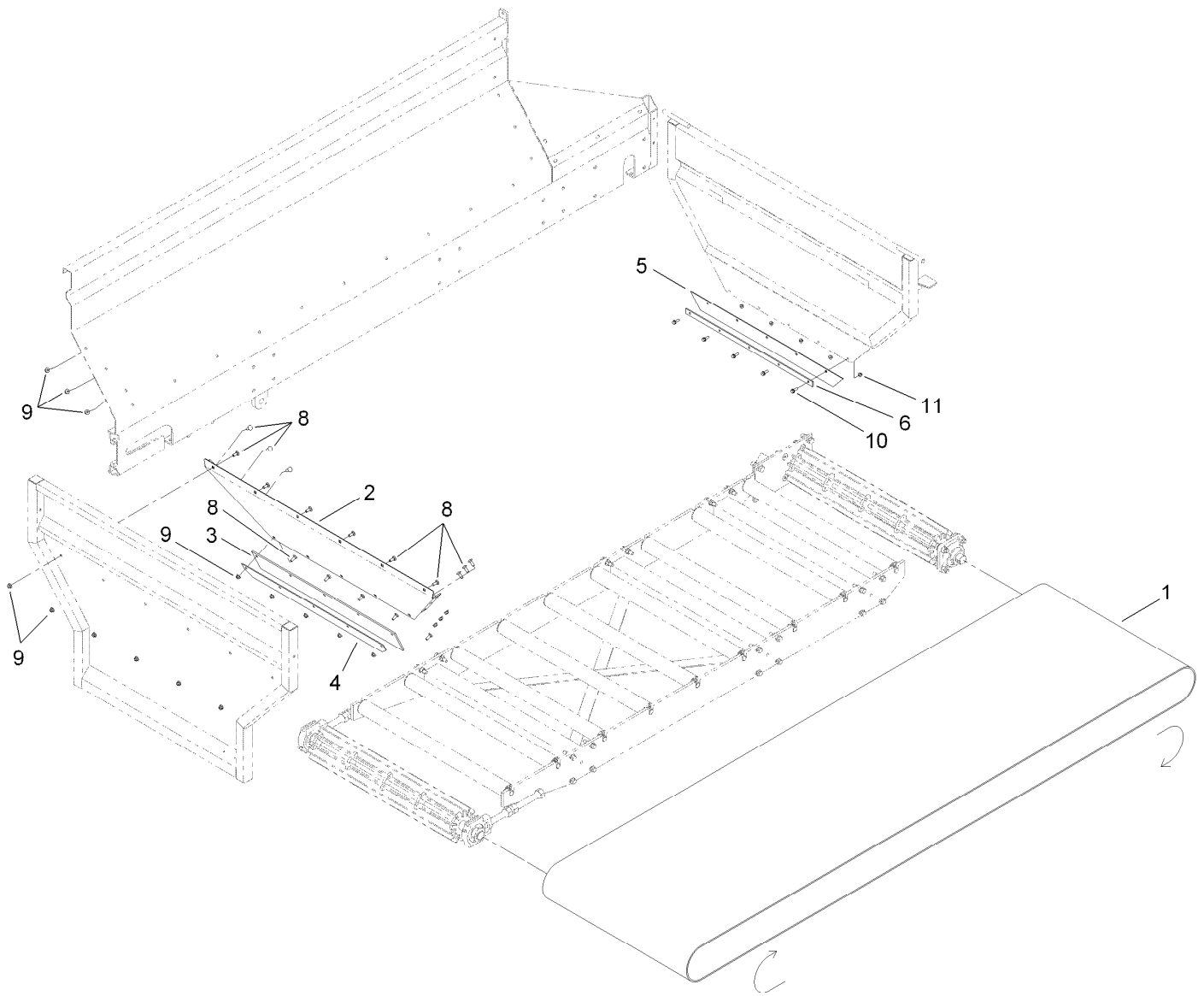

Belt and Skirting Assembly

<i>Ref.</i>	<i>Part Number</i>	<i>Qty.</i>	<i>Description</i>
1	T60191215	1	Belt-Endless
2	T36011525-01	1	Panel-Sloped
3	T01-22002B	1	Skirt-Front Seal, Rubber
4	T36011535-01	1	Bar-Front Seal
5	T36013010	1	Seal-Belt
6	T36011230-01	1	Retainer-Belt Seal
8	3231-22	17	Screw-CARR
9	104-8301	17	Nut-Flange, NI
10	3234-29	5	Screw-HHF
11	104-8300	5	Nut-Flange, NI

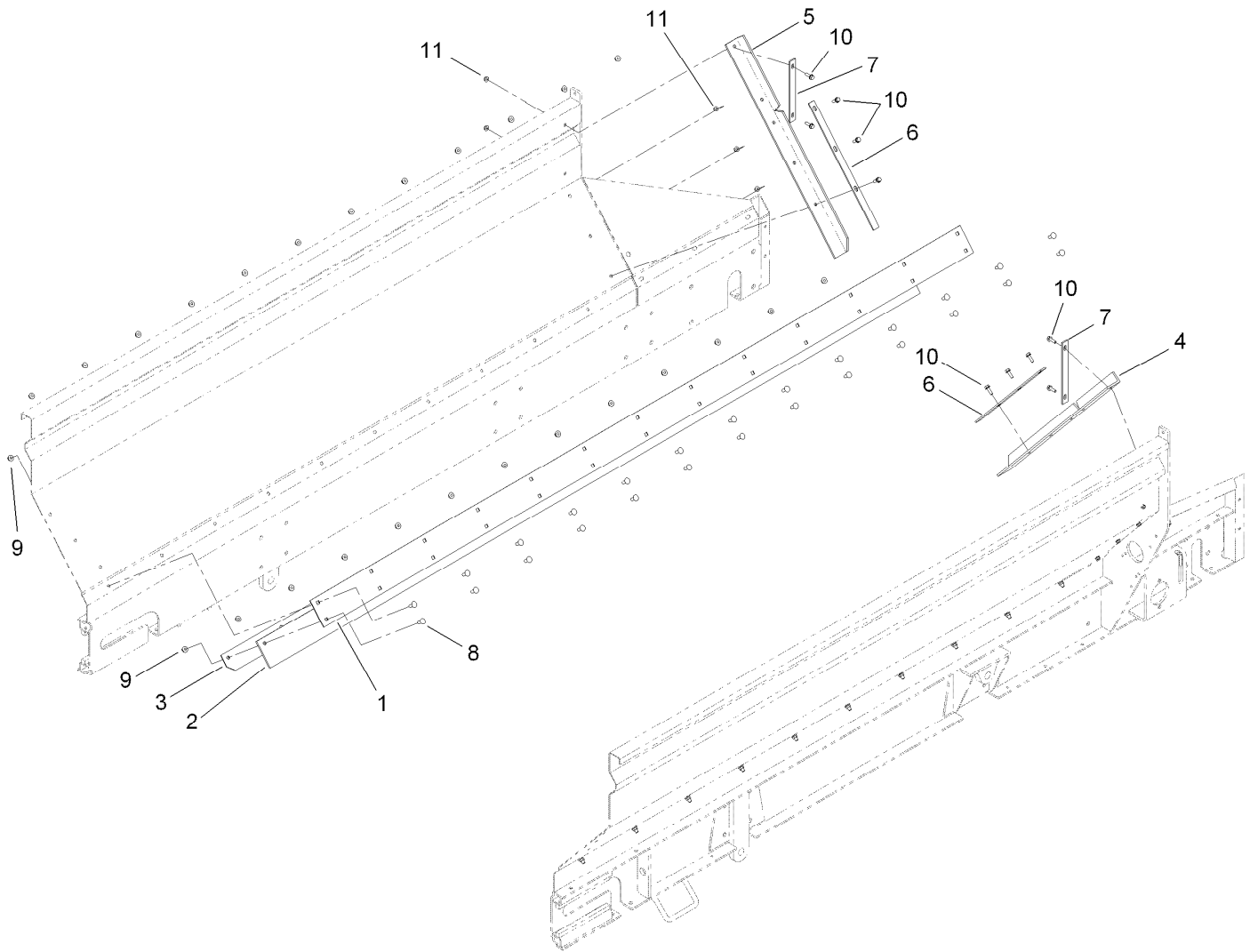

Skirting Assembly

Ref.	Part Number	Qty.	Description
1	T36011520-01	2	Panel-Side Seal
2	T01-22000B	2	Seal-Rubber, Side
3	T36011530-01	2	Bar-Side Seal
4	T36011260	1	Seal-Tailgate, LH
5	T36011270	1	Seal-Tailgate, RH
6	T36011280-01	2	Bar-Seal, Lower
7	T36011290-01	2	Bar-Seal, Upper
8	3231-22	52	Screw-CARR
9	104-8301	52	Nut-Flange, NI
10	3234-29	10	Screw-HHF
11	104-8300	10	Nut-Flange, NI

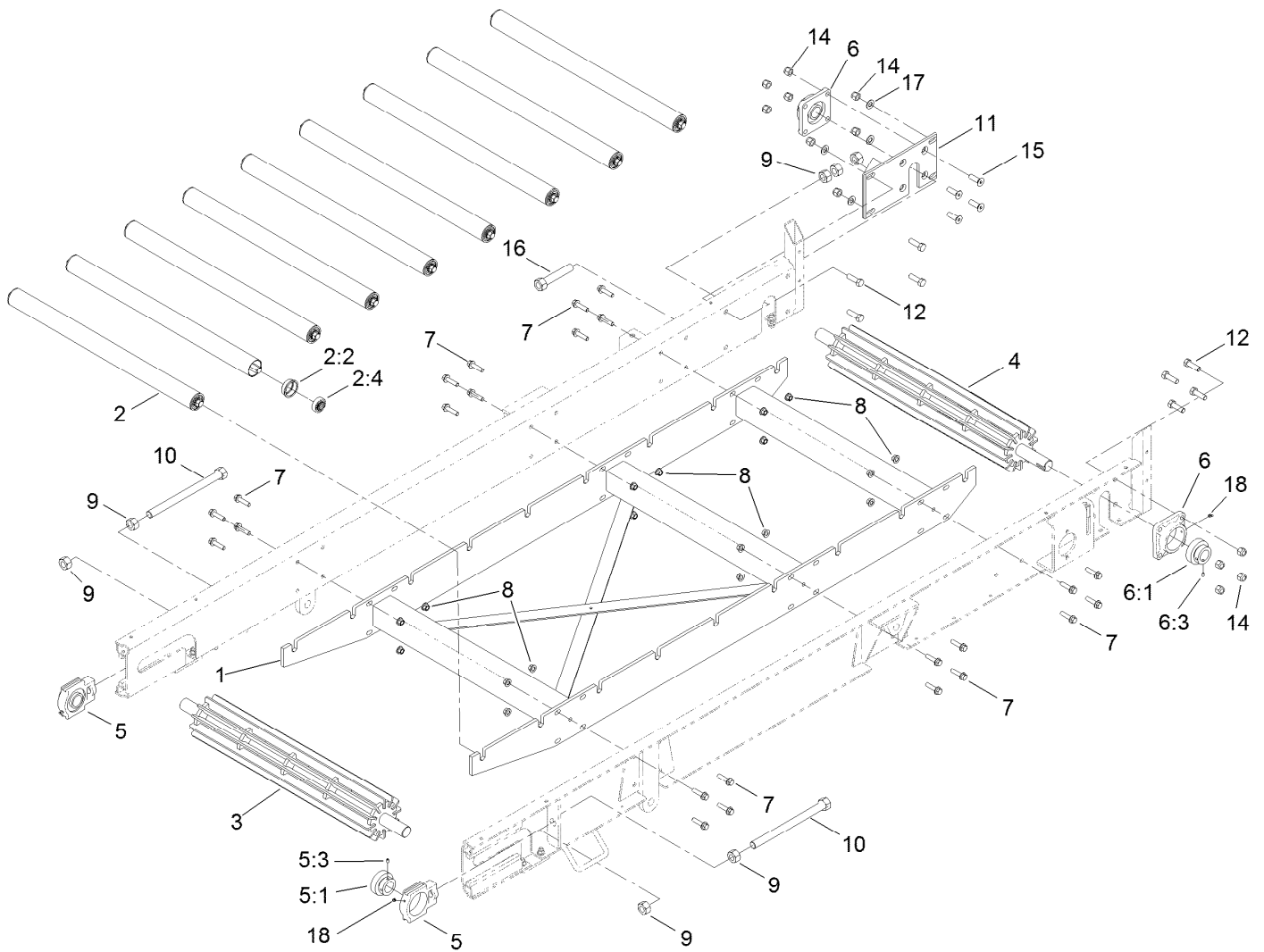

Conveyor Assembly

<i>Ref.</i>	<i>Part Number</i>	<i>Qty.</i>	<i>Description</i>	<i>Ref.</i>	<i>Part Number</i>	<i>Qty.</i>	<i>Description</i>
1	T36011600-01	1	Frame-Roller	7	3234-27	24	Screw-HHF
2	T36011680	9	Belt Roller ASM	8	99-5107	24	Nut-Lock
2:2	T36011685	2	Insert-Roller	9	SG330081	7	Nut-Hex
2:4	T60111000	2	Bearing-Ball	10	T36011670	2	Rod-Tensioner
3	T36011620-03	1	Rooler-Idler	11	T36011690-01	1	Plate-Mounting
4	119-6892-03	1	Roller-Drive	12	327-6	8	Screw-HH
5	T60114305	2	Take-Up Bearing ASM	14	3296-53	12	Nut-Lock, NI
5:1	120-0817	1	Bearing-Collar, Lock	15	120-0904	4	Screw-HSH
5:3	3246-17	1	Setscrew-HSH	16	T36011675	1	Rod-Lock
6	T60116355	2	4-Bolt Bearing ASM	17	3256-27	4	Washer-Flat
6:1	120-0817	1	Bearing-Collar, Lock	18	302-61	4	Fitting-Grease
6:3	3246-17	1	Setscrew-HSH				

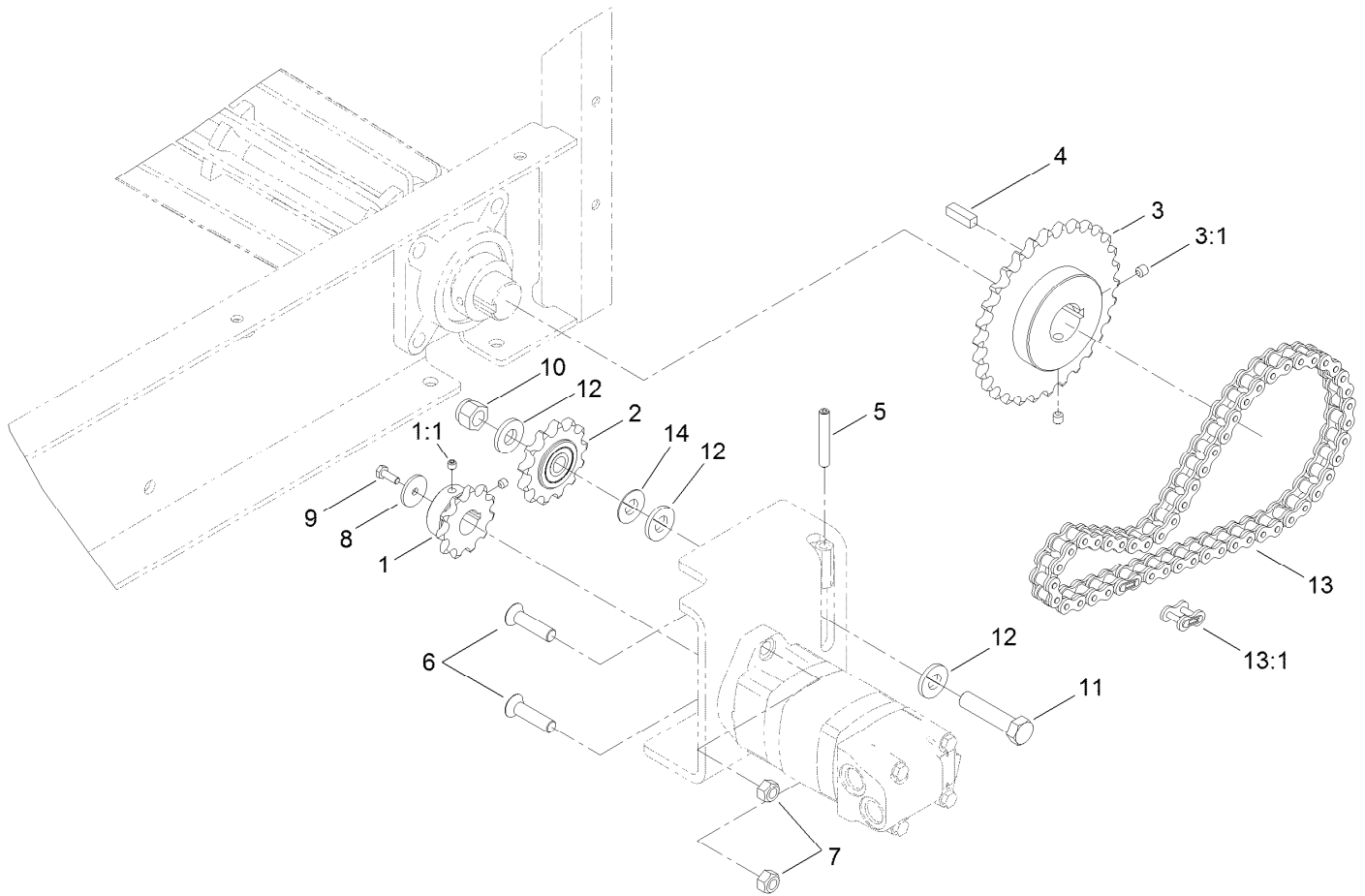

Chain Drive Assembly

<i>Ref.</i>	<i>Part Number</i>	<i>Qty.</i>	<i>Description</i>
1	T60135010	1	Sprocket
1:1	3246-2	2	Screw-Set, HSH
2	T60134090	1	Sprocket
3	T60135750	1	Sprocket
3:1	3247-2	2	Screw-Set, HSH
4	T36011810	1	Key
5	120-0909	1	Screw-HSH
6	120-0898	2	Screw-Fhhs
7	97-1206	2	Locknut

<i>Ref.</i>	<i>Part Number</i>	<i>Qty.</i>	<i>Description</i>
8	103995	1	Washer
9	321-4	1	Screw-HH
10	3296-53	1	Nut-Lock, NI
11	327-8	1	Screw-HH
12	99-7667	3	Washer-Flat
13	T36011800	1	Chain-Drive, 39 Inch
13:1	T60151016	1	Link-Connecting, #60
14	3256-27	1	Washer-Flat

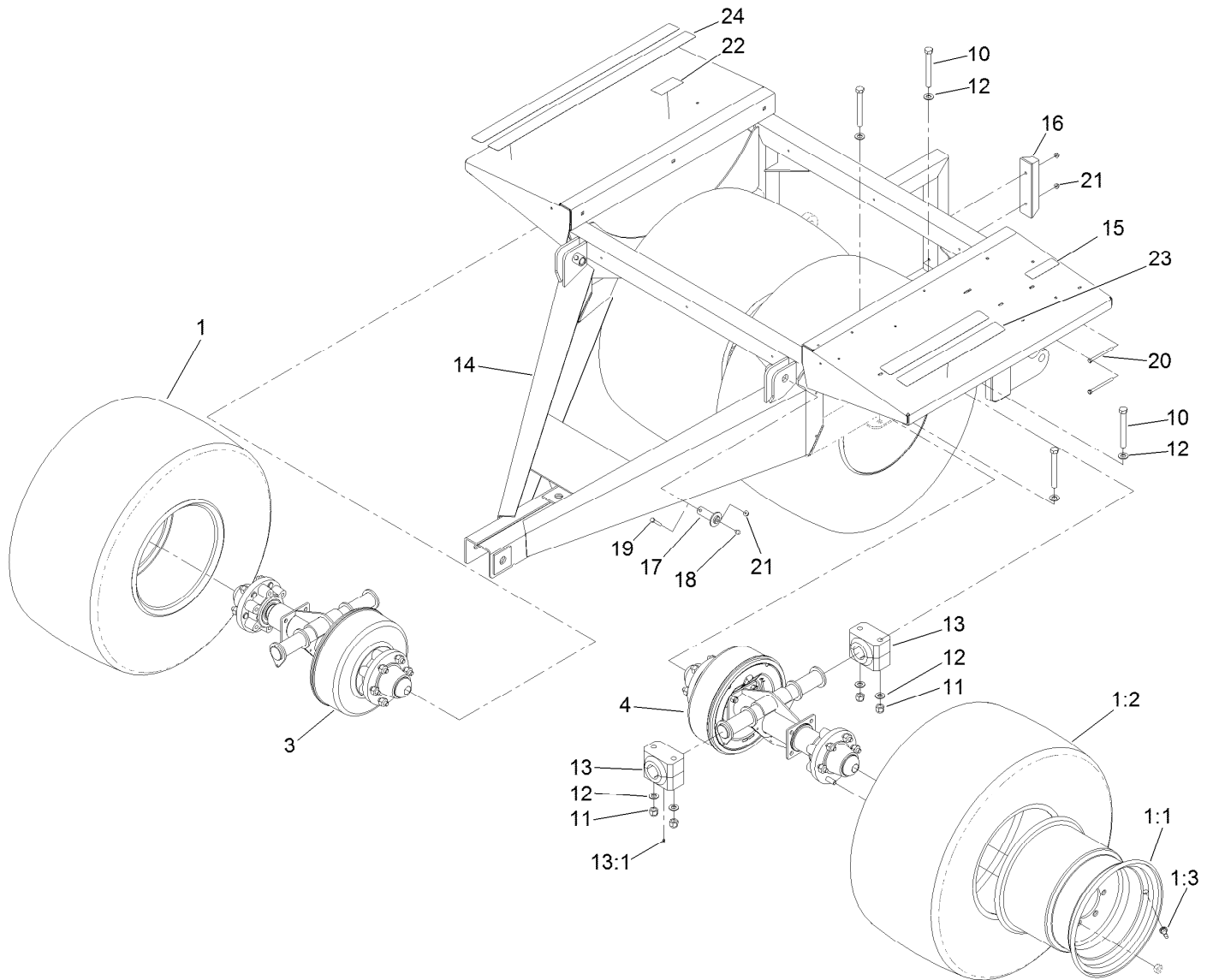

Wheel Assembly

Ref.	Part Number	Qty.	Description	Ref.	Part Number	Qty.	Description
1	120-9410	4	Wheel And Tire ASM	14	T01-43164D-01	1	Frame
1:1	120-9411	1	Wheel-Turf	15	119-6823	1	Decal-Hydraulic Control
1:2	120-9412	1	Tire-Turf	16	T62011021	1	Bumper-Rubber
1:3	232-24	1	Stem-Valve	17	T36012070-01	2	Pin-Hinge
3	120-9401	1	RH Shaft ASM	18	302-2	2	Fitting-Grease
4	120-9402	1	LH Shaft ASM	19	322-10	2	Screw-HH
10	120-0923	8	Screw-HH	20	322-19	2	Screw-HH
11	120-0924	8	Nut-Lock, NI	21	104-8300	4	Nut-Flange, NI
12	119-1868	16	Washer	22	119-6835	1	Decal-Jack
13	T60111196	4	Bearing-Polyurethane	23	T36013050	2	Thread-Walk, Safety
13:1	302-19	1	Fitting-Grease	24	T36013052	2	Thread-Walk, Safety

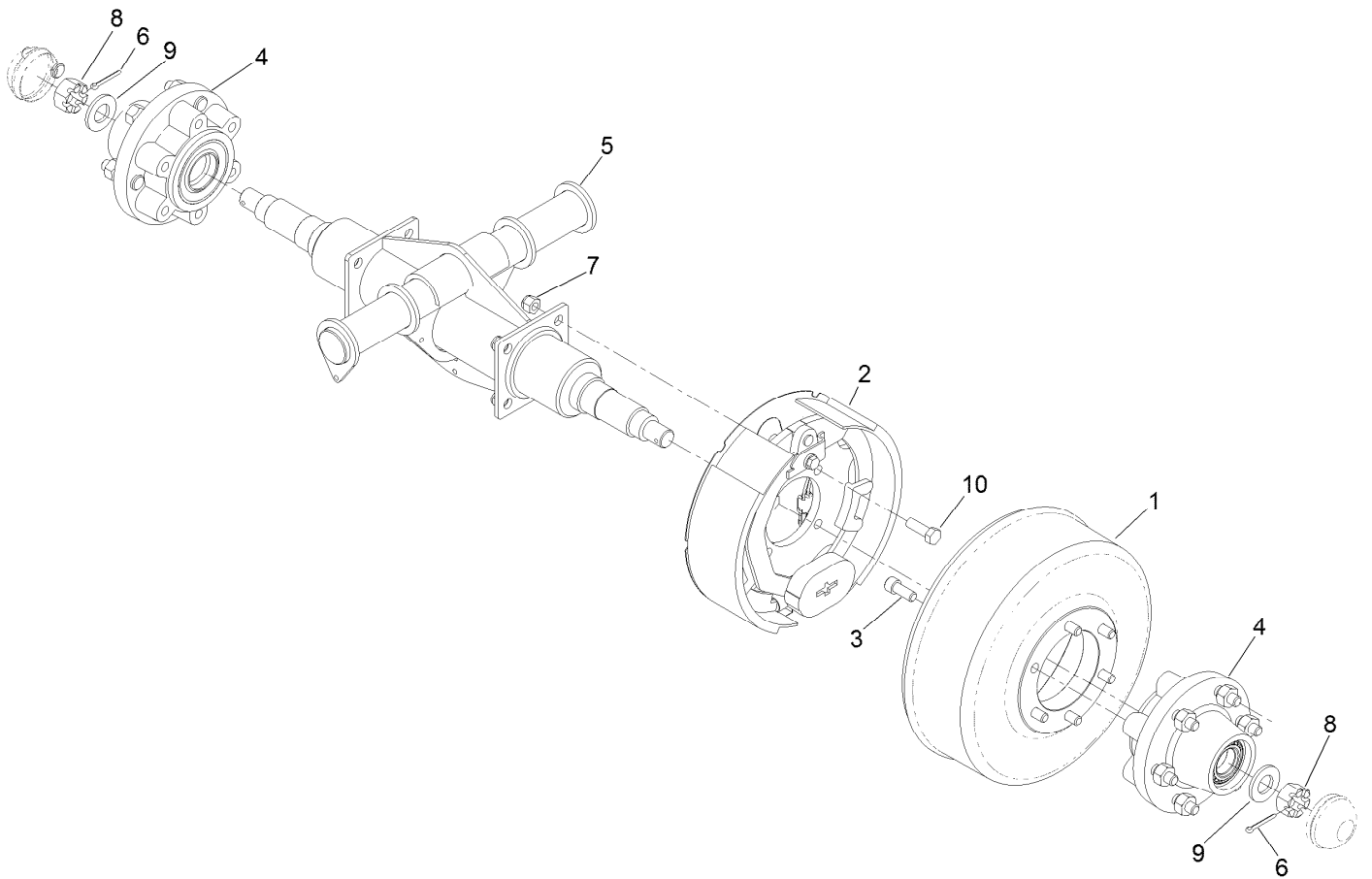

RH Shaft Assembly No. 120-9401

Ref.	Part Number	Qty.	Description
1	119-6871	1	Drum-Brake
2	120-9437	1	LH Brake ASM
3	120-0940	6	Screw-HSH
4	120-9404	2	Hub ASM
5	120-9405-03	1	Beam-Walking
6	3272-23	2	Pin-Cotter
7	3296-19	4	Nut-Hex
8	32136-11	2	Nut-Hex, Slot
9	T54051068	2	Washer-Spindle
10	325-6	4	Screw-HH

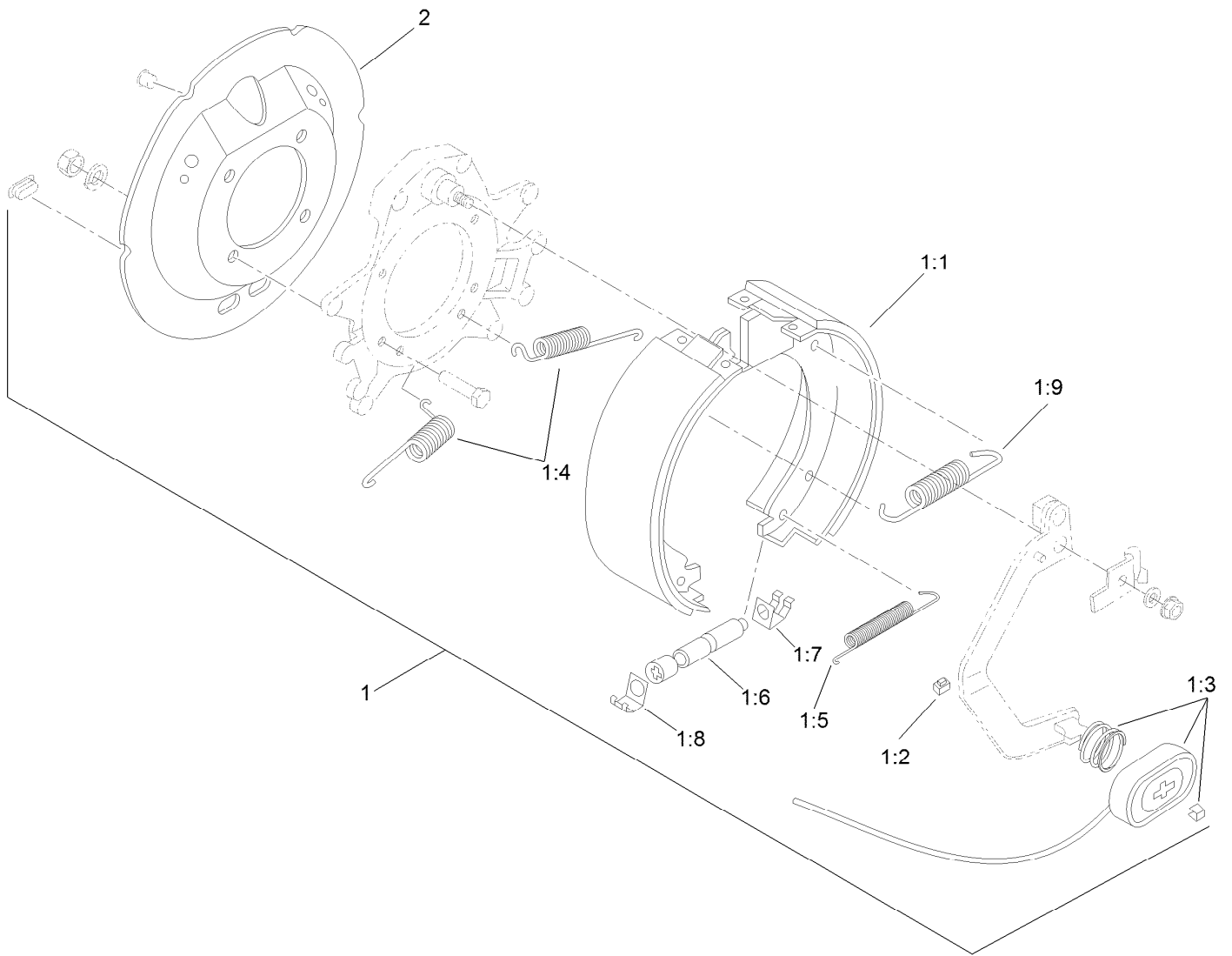

LH Brake Assembly No. 120-9437

<i>Ref.</i>	<i>Part Number</i>	<i>Qty.</i>	<i>Description</i>
1		1	Brake-LH ●
1:1	120-9441	1	LH Shoe And Lining Kit
1:2	120-9443	1	Clip-Wire
1:3	120-9444	1	Magnet Kit
1:4	120-9445	2	Spring-Centering
1:5	120-9446	1	Spring-Adjuster
1:6	120-9447	1	Adjuster Assembly
1:7	120-9448	1	Clip-Adjuster
1:8	120-9449	1	Clip-Adjuster
1:9	120-9396	1	Spring-Return
2	120-9433	1	Cover-Dust, Brake

● Not serviced separately

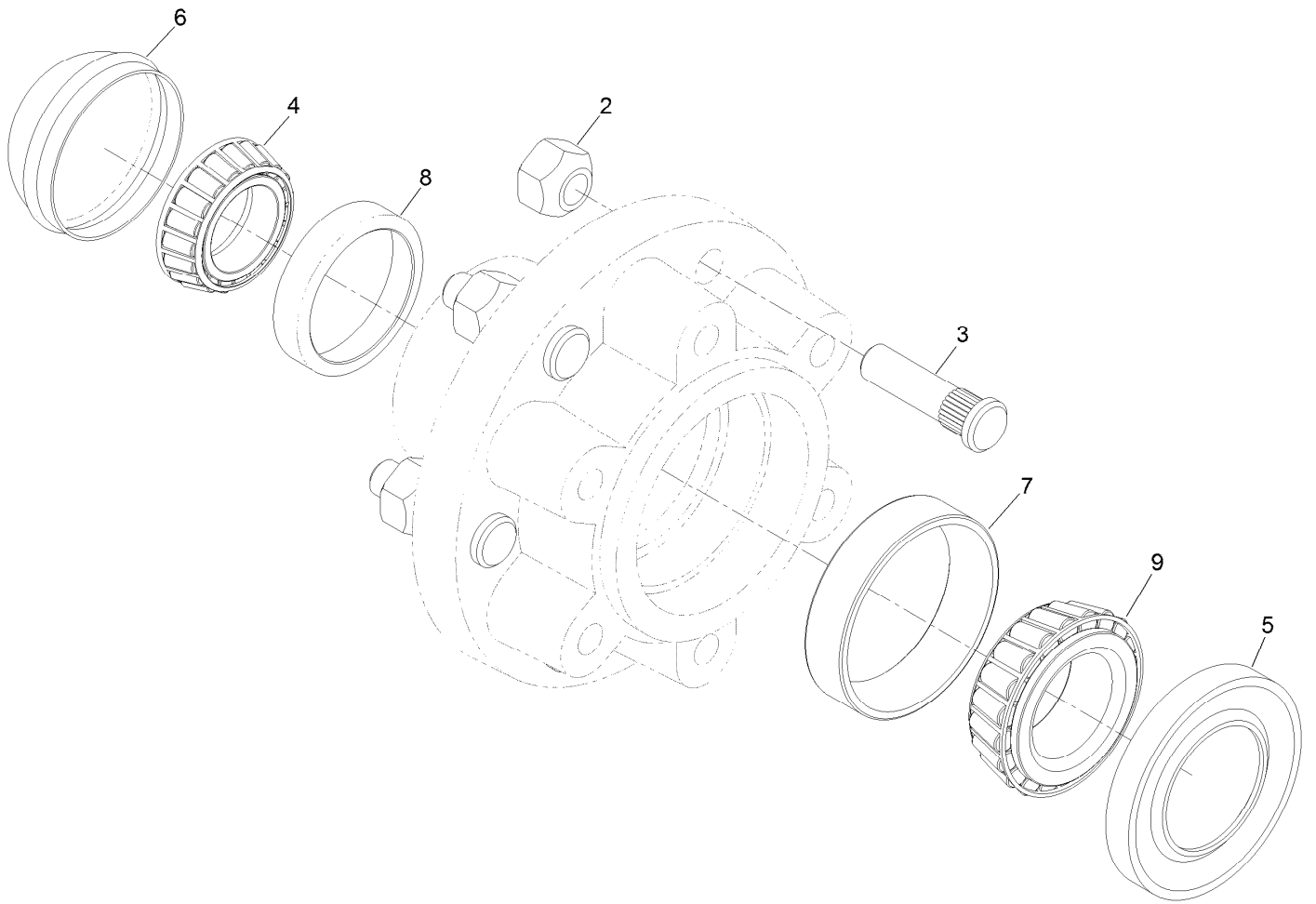

Hub Assembly No. 120-9404

<i>Ref.</i>	<i>Part Number</i>	<i>Qty.</i>	<i>Description</i>
2	T54031040	6	Nut-Wheel
3	T54031042	6	Stud-Wheel
4	T54051010	1	Bearing-Hub, Outer
5	T54051019	1	Seal-Bearing
6	T54051026	1	Cap-Hub (5000/6000 Lb.)
7	T54051037	1	Race-Bearing, Inner
8	T54051042	1	Races-Bearing, Outer
9	T54051100	1	Bearing-Hub, Inner

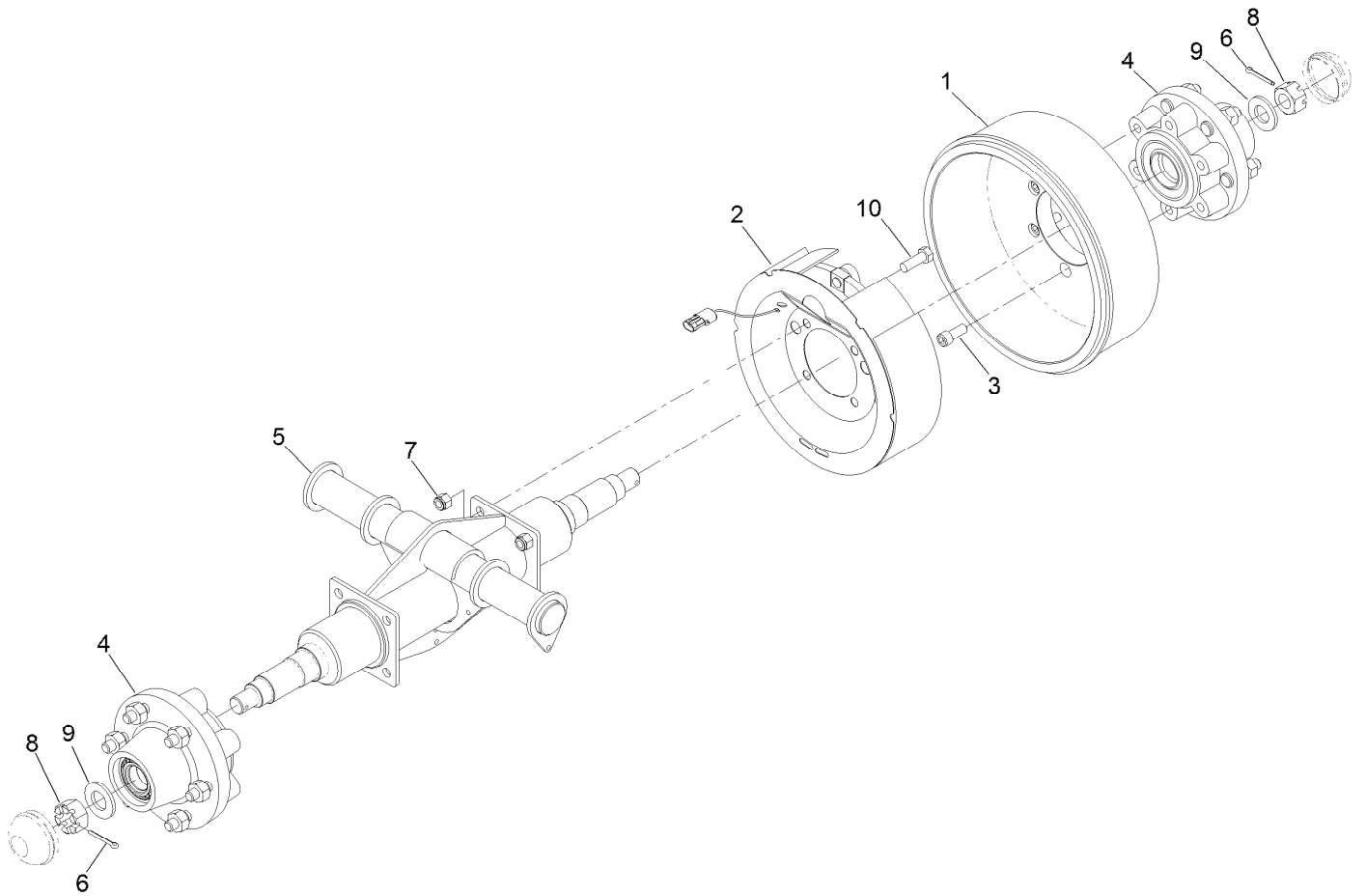

LH Shaft Assembly No. 120-9402

Ref.	Part Number	Qty.	Description
1	119-6871	1	Drum-Brake
2	120-9436	1	RH Brake ASM
3	120-0940	6	Screw-HSH
4	120-9404	2	Hub ASM
5	120-9405-03	1	Beam-Walking
6	3272-23	2	Pin-Cotter
7	3296-19	4	Nut-Hex
8	32136-11	2	Nut-Hex, Slot
9	T54051068	2	Washer-Spindle
10	325-6	4	Screw-HH

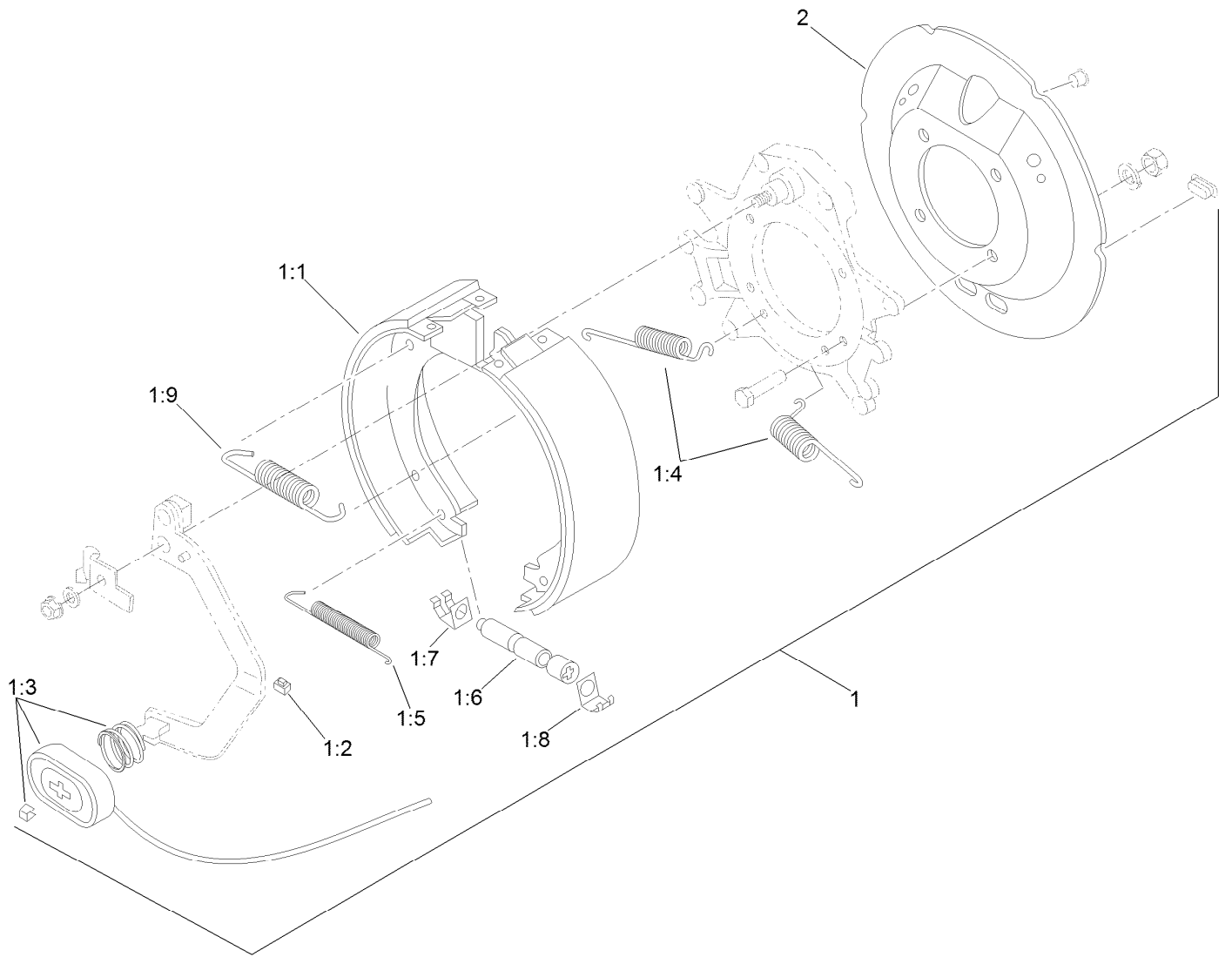

RH Brake Assembly No. 120-9436

Ref.	Part Number	Qty.	Description
1		1	Brake-RH ●
1:1	120-9442	1	RH Shoe And Lining Kit
1:2	120-9443	1	Clip-Wire
1:3	120-9444	1	Magnet Kit
1:4	120-9445	2	Spring-Centering
1:5	120-9446	1	Spring-Adjuster
1:6	120-9447	1	Adjuster Assembly
1:7	120-9448	1	Clip-Adjuster
1:8	120-9449	1	Clip-Adjuster
1:9	120-9396	1	Spring-Return
2	120-9433	1	Cover-Dust, Brake

● Not serviced separately

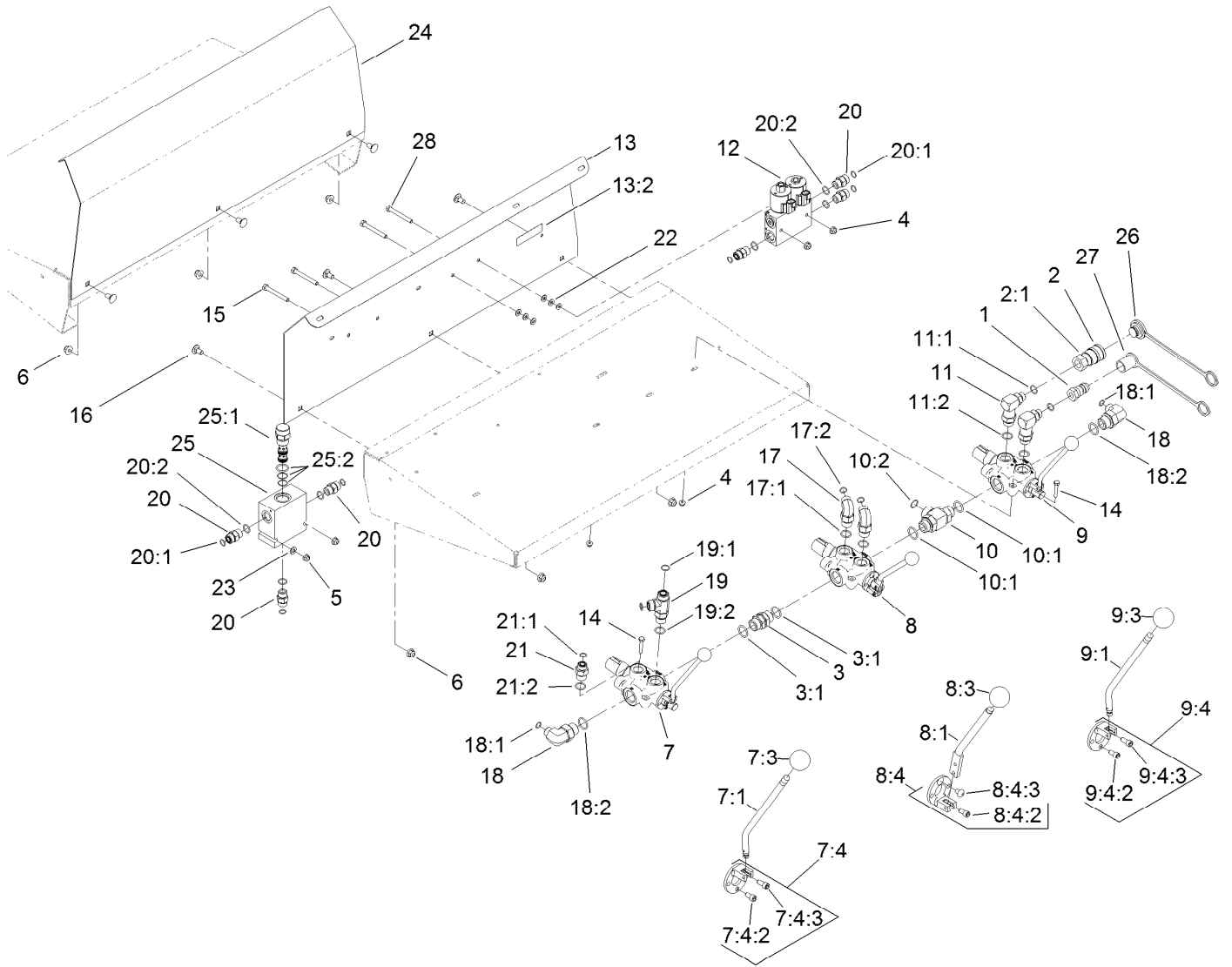

Hydraulic Valve and Manifold Assembly

Ref.	Part Number	Qty.	Description
1	98-4698	1	Male-Disconnect, Quick
2	98-4699	1	Female-Disconnect, Quick
2:1	100-4165	1	Seal Kit
3	98-9906	1	Fitting-Thread, Straight
3:1	237-81	2	O-Ring
4	104-7201	4	Nut-HF
5	104-8300	4	Nut-Flange, NI
6	104-8301	6	Nut-Flange, NI
7	120-0835	1	Hydraulic Valve ASM
7:1	T36013200	1	Lever (Belt Or Option)
7:2	T56051070	1	Wiper-Seal ●
7:3	T56051500	1	Knob
7:4	T56051610	1	Hydraulic Valve Clevis Kit
7:4:2	3274-42	1	Screw-HSH
7:4:3	3274-52	1	Screw-HSH
8	120-0836	1	Hydraulic Valve ASM
8:1	T56053070	1	Lever
8:2	T56051070	1	Wiper-Seal ●

Ref.	Part Number	Qty.	Description
8:3	T56051500	1	Knob
8:4	T56051066	1	Hydraulic Valve Clevis Kit
8:4:2	3274-42	1	Screw-HSH
8:4:3	3274-31	1	Screw-HSBH
9	120-0837	1	Hydraulic Valve ASM
9:1	T36013200	1	Lever (Belt Or Option)
9:2	T56051070	1	Wiper-Seal ●
9:3	T56051500	1	Knob
9:4	T56051610	1	Hydraulic Valve Clevis Kit
9:4:2	3274-42	1	Screw-HSH
9:4:3	3274-52	1	Screw-HSH
10	120-0844	1	Fitting-Tee
10:1	237-81	2	O-Ring
10:2	237-58	1	O-Ring
11	120-0847	2	Fitting-Elbow-90
11:1	237-79	1	O-Ring
11:2	237-80	1	O-Ring

● Not illustrated

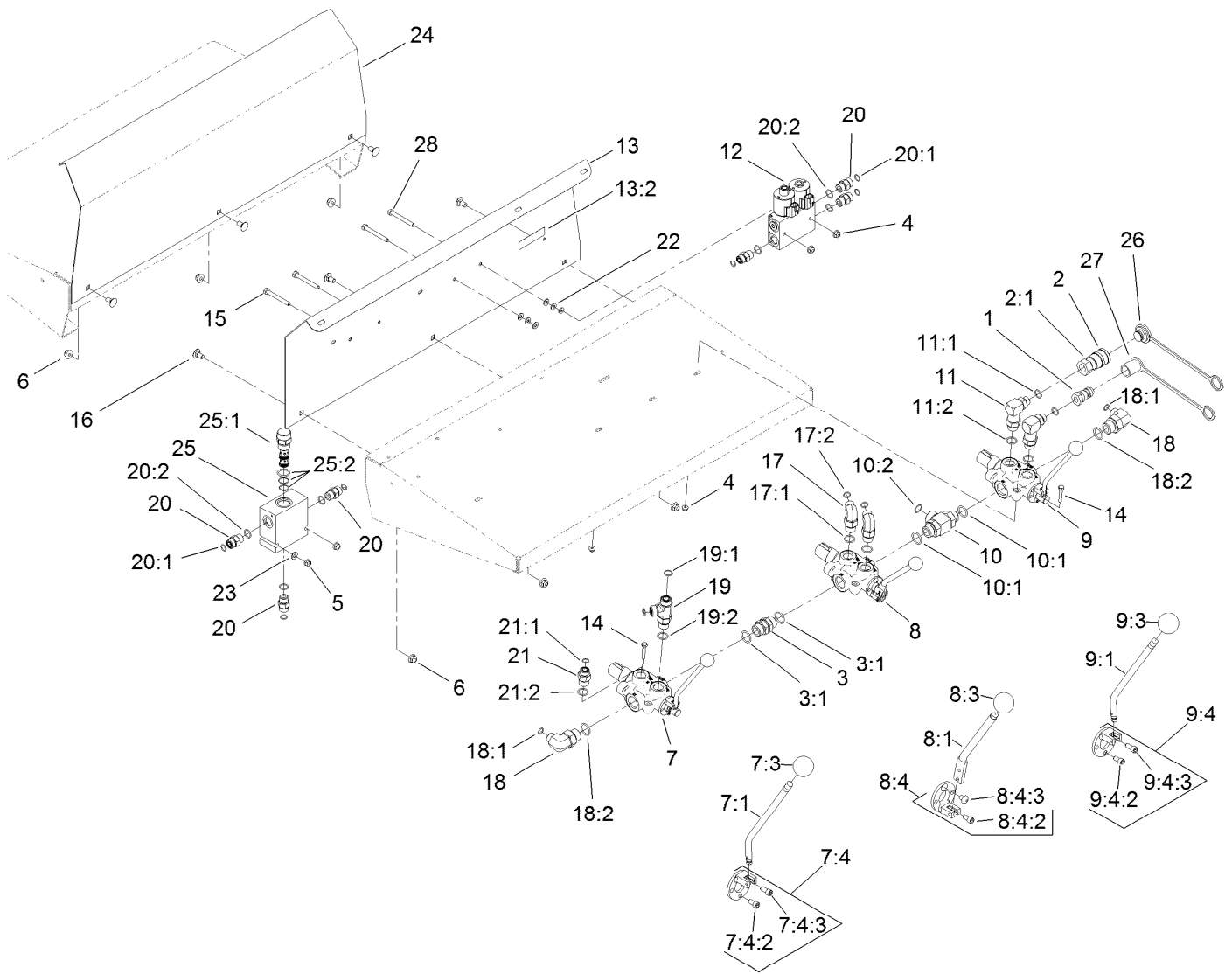

Hydraulic Valve and Manifold Assembly (continued)

Ref.	Part Number	Qty.	Description	Ref.	Part Number	Qty.	Description
12	120-0850	1	Conveyor Belt Manifold ASM	20:1	237-30	1	O-Ring
13	120-0921	1	LH Fender Guard Service ASM	20:2	237-79	1	O-Ring
13:2	119-0217	1	Decal-Danger	21	340-6	1	Fitting-HYD, Straight
14	321-43	2	Capscrew	21:1	237-30	1	O-Ring
15	322-13	2	Screw-HH	21:2	237-80	1	O-Ring
16	3231-1	6	Screw-CARR	22	3256-22	6	Washer-Flat
17	340-105	2	Fitting-HYD, 90 DEG	23	3256-23	2	Washer-Flat
17:1	237-80	1	O-Ring	24	T36011720-01	1	Guard-Fender, RH
17:2	237-30	1	O-Ring	25	T56051020	1	Valve-HYD
18	340-131	2	Fitting-HYD, 90 DEG	25:1	120-0851	1	Valve-Cartridge, Pressure Comp
18:1	237-30	1	O-Ring	25:2	114-5515	1	Seal Kit
18:2	237-81	1	O-Ring	26	T56152150	1	Plug-Quick Connect, 1/2 Inch
19	340-22	1	Fitting-HYD, Tee	27	T56152152	1	Cap-Quick Connect, 1/2 Inch
19:1	237-65	2	O-Ring	28	321-18	2	Screw-HH
19:2	237-80	1	O-Ring				
20	340-4	6	Fitting-HYD, Straight				

● Not illustrated

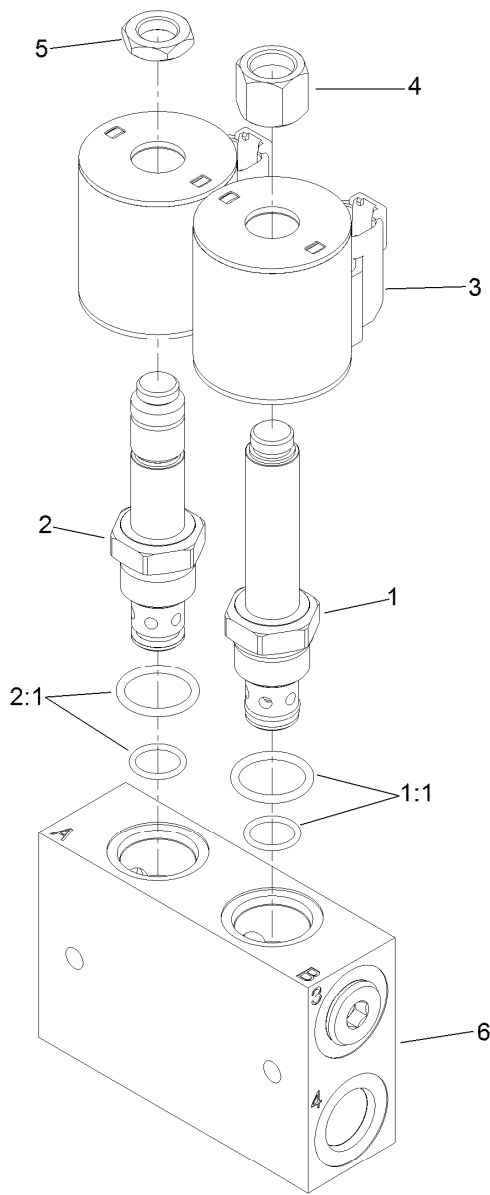

Hydraulic Valve Assembly No. 120-0850

<i>Ref.</i>	<i>Part Number</i>	<i>Qty.</i>	<i>Description</i>
1	105-9158	1	Valve-Solenoid, N.O.
1:1	105-9159	1	Seal Kit ●
2	120-0913	1	Valve-Solenoid
2:1	105-9159	1	Seal Kit
3	115-3021	2	Coil-12V
4	110-2635	1	Nut-Coil
5	110-2634	1	Nut-Coil
6	T56054030	1	Body-Hydr Valve

● Not illustrated

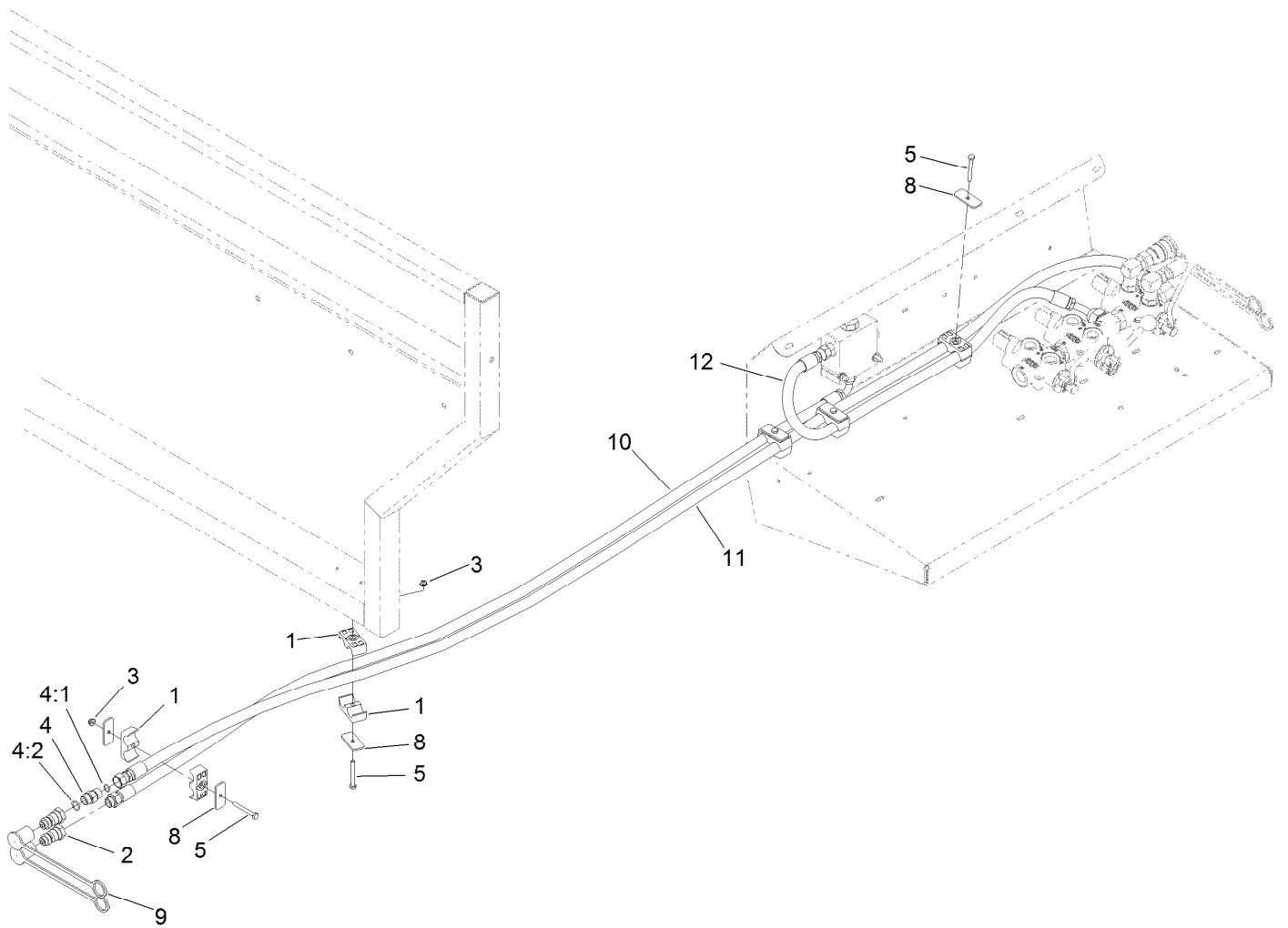

Hydraulic Hose and Clamp Assembly

Ref.	Part Number	Qty.	Description
1	56-7974	10	Clamp-Tube
2	98-4698	2	Male-Disconnect, Quick
3	104-7201	5	Nut-HF
4	119-6898	1	Valve-Check, HYD
4:1	237-30	1	O-Ring
4:2	237-79	1	O-Ring
5	321-18	5	Screw-HH
8	T36033040	6	Plate-Clamp
9	T56152152	2	Cap-Quick Connect, 1/2 Inch
10	120-0862	1	Hose-HYD
11	120-0863	1	Hose-HYD
12	120-0874	1	Hose-HYD

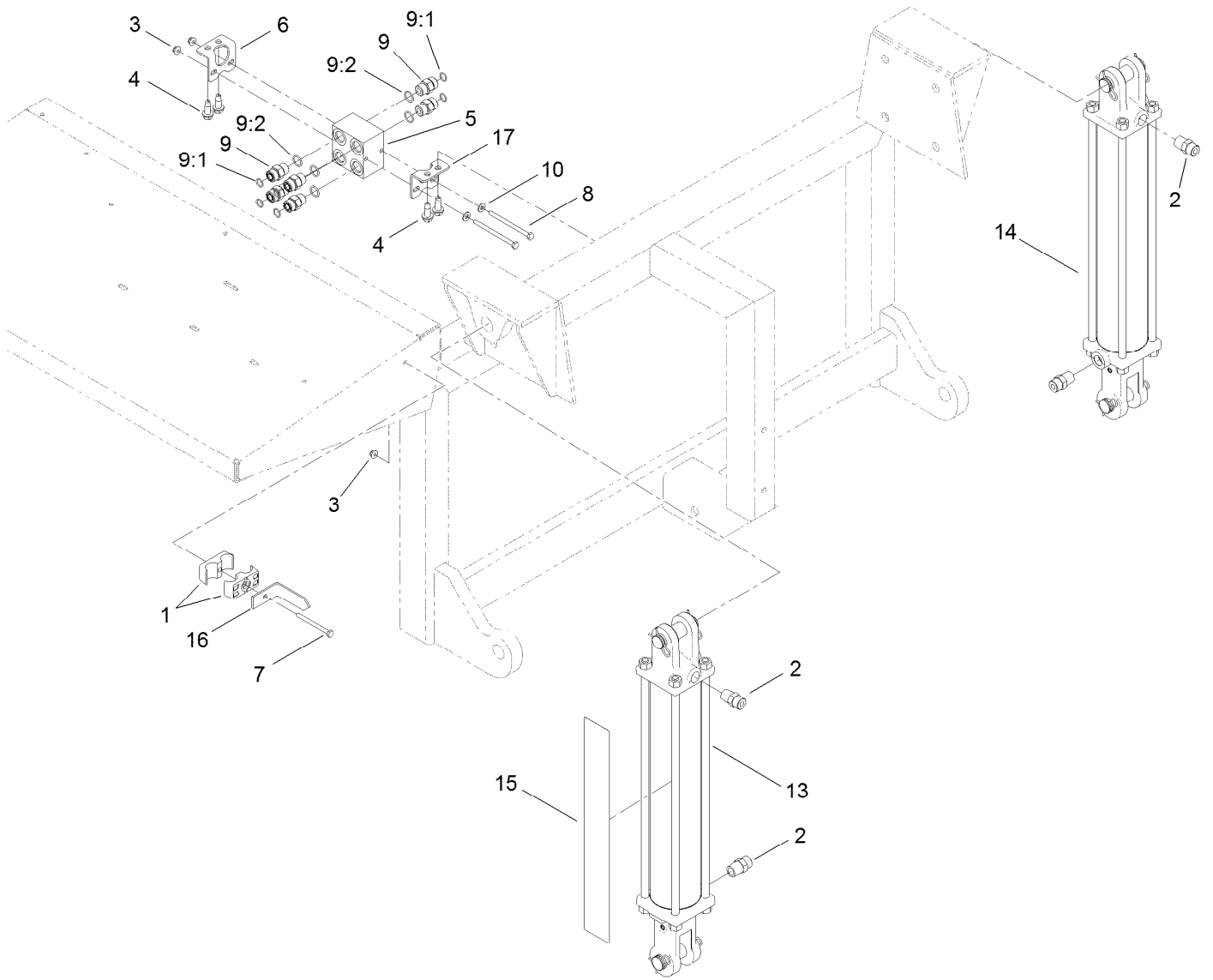

Hydraulic Cylinder and Junction Box Manifold Assembly

Ref.	Part Number	Qty.	Description
1	56-7974	2	Clamp-Tube
2	93-5107	4	Fitting-Adapter
3	104-7201	3	Nut-HF
4	105-6245	4	Screw-Tapping
5	120-0848	1	Manifold-Junction Block
6	120-0875-03	1	Bracket-Mounting, Manifold
7	321-18	1	Screw-HH
8	321-28	2	Screw-HH
9	340-4	6	Fitting-HYD, Straight

Ref.	Part Number	Qty.	Description
9:1	237-30	1	O-Ring
9:2	237-79	1	O-Ring
10	3256-22	2	Washer-Flat
13	T56071160	1	HYD Cylinder ASM
14	T56071170	1	HYD Cylinder ASM
15	119-6863	1	Decal-Load Range
16	T36011570	1	Bar-Indicator, Lift
17	120-0983-03	1	Bracket-Manifold

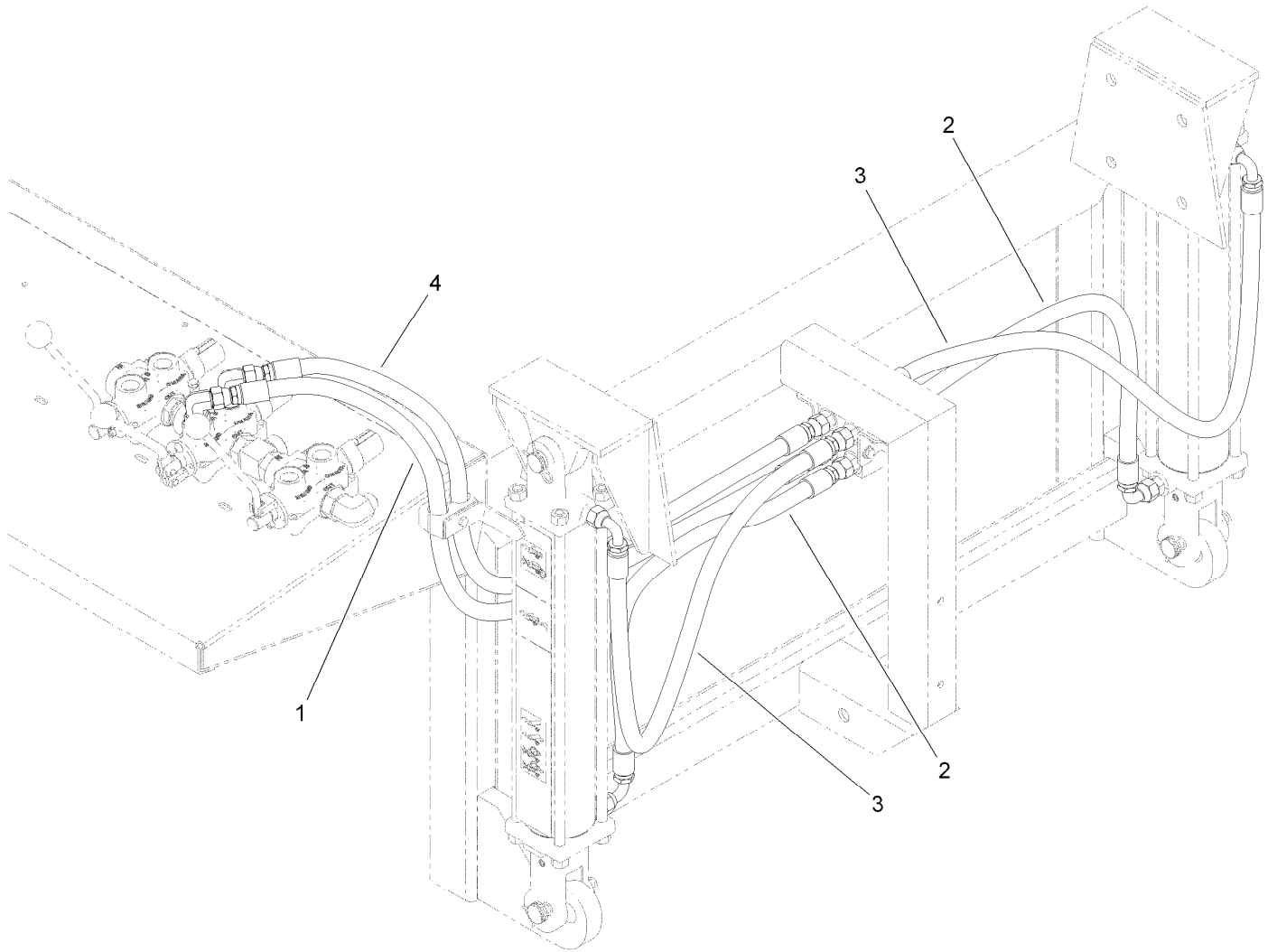

Hydraulic Hose Assembly

<i>Ref.</i>	<i>Part Number</i>	<i>Qty.</i>	<i>Description</i>
1	120-0980	1	Hose-HYD
2	120-0869	2	Hose-HYD
3	120-0870	2	Hose-HYD
4	120-0981	1	Hose-HYD

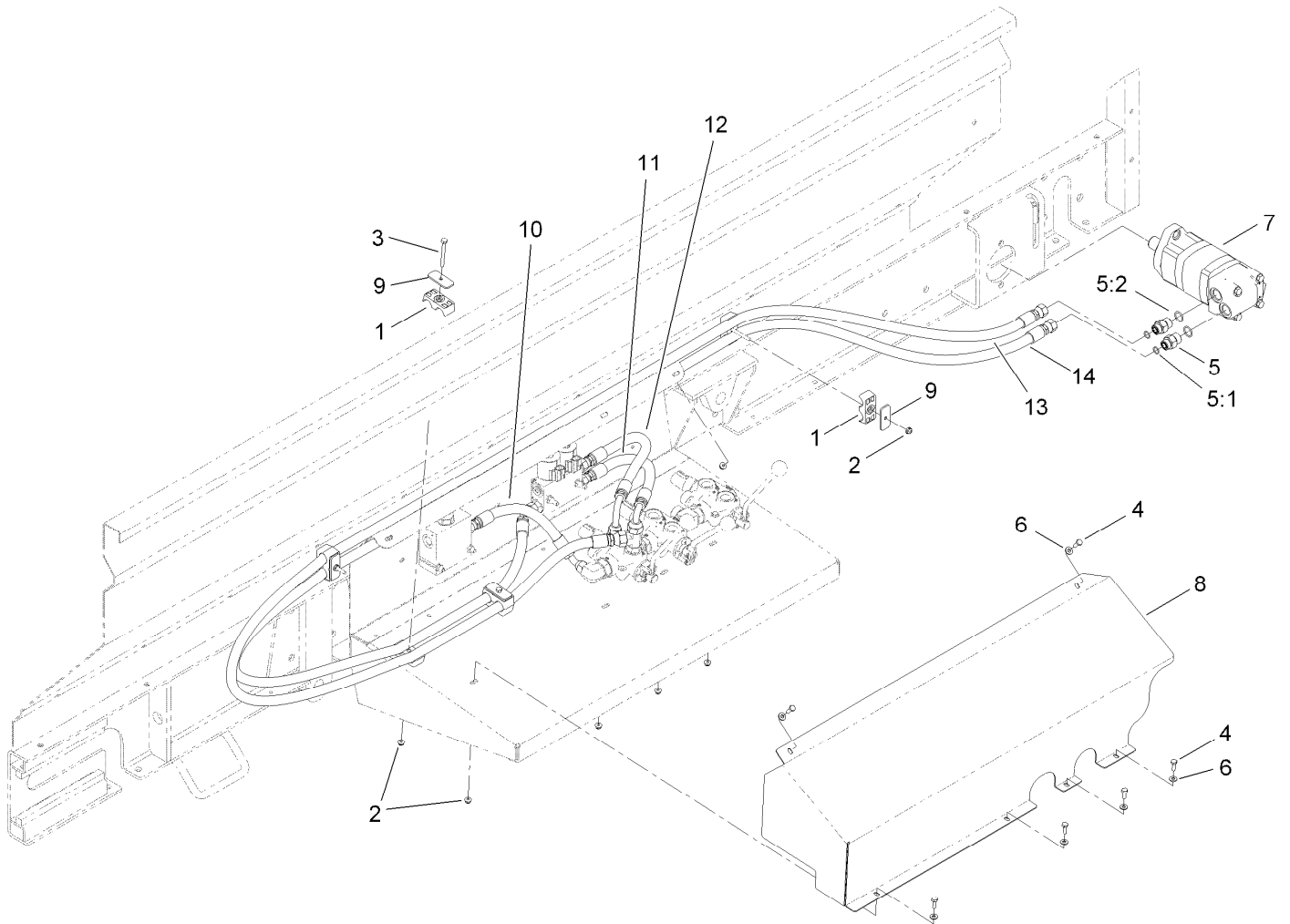

Hydraulic Guard Box Assembly

<i>Ref.</i>	<i>Part Number</i>	<i>Qty.</i>	<i>Description</i>	<i>Ref.</i>	<i>Part Number</i>	<i>Qty.</i>	<i>Description</i>
1	56-7974	8	Clamp-Tube	7	T0000-5303	1	HYD Motor ASM
2	104-7201	10	Nut-HF	8	T36011770-01	1	Guard-Hydraulic
3	321-18	2	Screw-HH	9	T36033040	4	Plate-Clamp
4	321-4	6	Screw-HH	10	120-0858	1	Hose-HYD
5	340-6	2	Fitting-HYD, Straight	11	120-0860	1	Hose-HYD
5:1	237-30	1	O-Ring	12	120-0861	1	Hose-HYD
5:2	237-80	1	O-Ring	13	120-0864	1	Hose-HYD
6	3256-22	6	Washer-Flat	14	119-4591	1	Hose-HYD

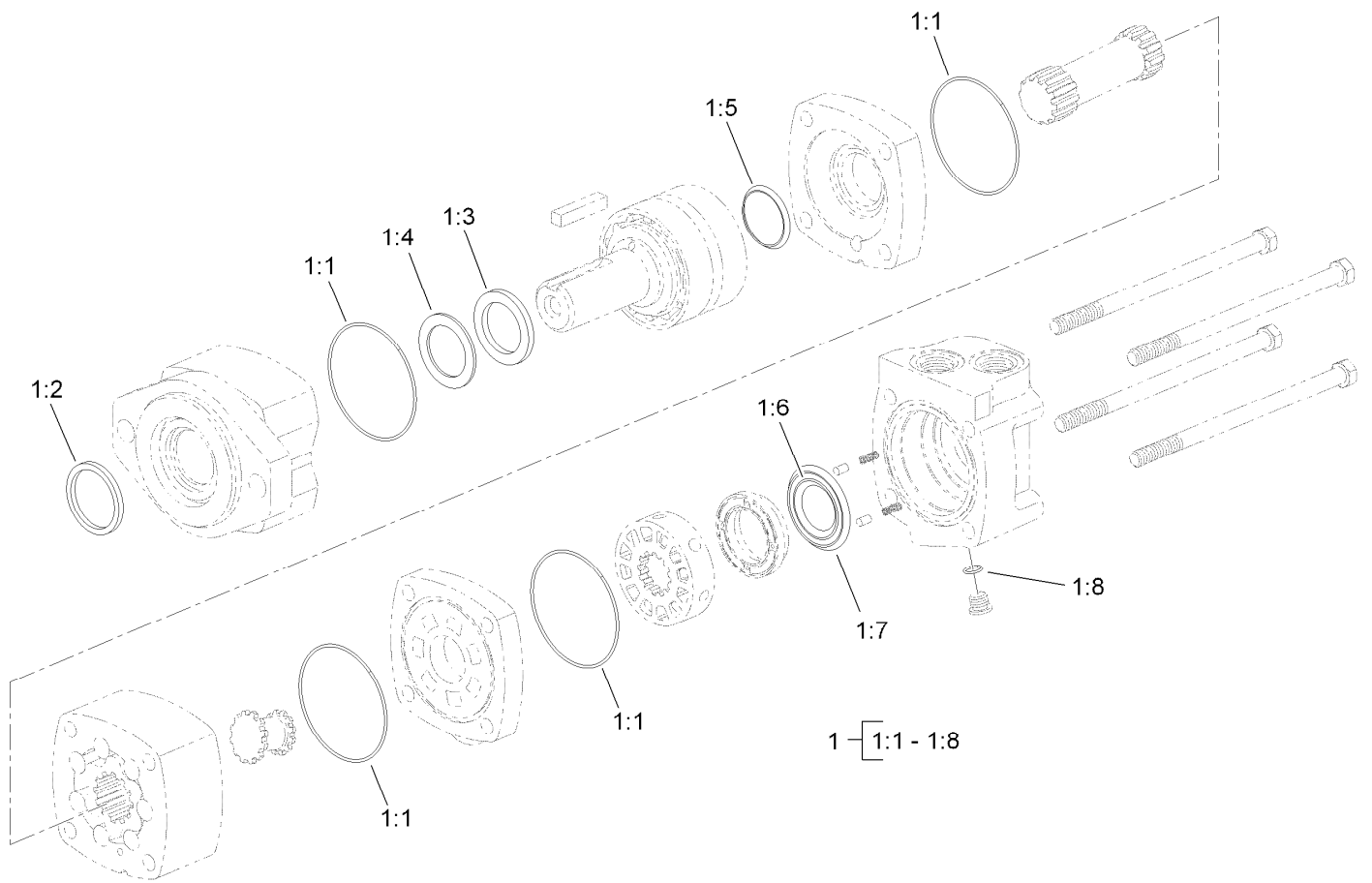

Hydraulic Motor Assembly No. T0000-5303

Ref.	Part Number	Qty.	Description
1	56-6890	1	Seal Kit
1:1		4	O-Ring ●
1:2		1	Seal-Exclusion, Shaft ●
1:3		1	Seal-Shaft ●
1:4		1	Ring-Back-Up ●
1:5		1	Seal-Face, Shaft ●
1:6		1	Seal-Face, Inner ●
1:7		1	Seal-Face, Outer ●
1:8		1	O-Ring ●

● Not serviced separately

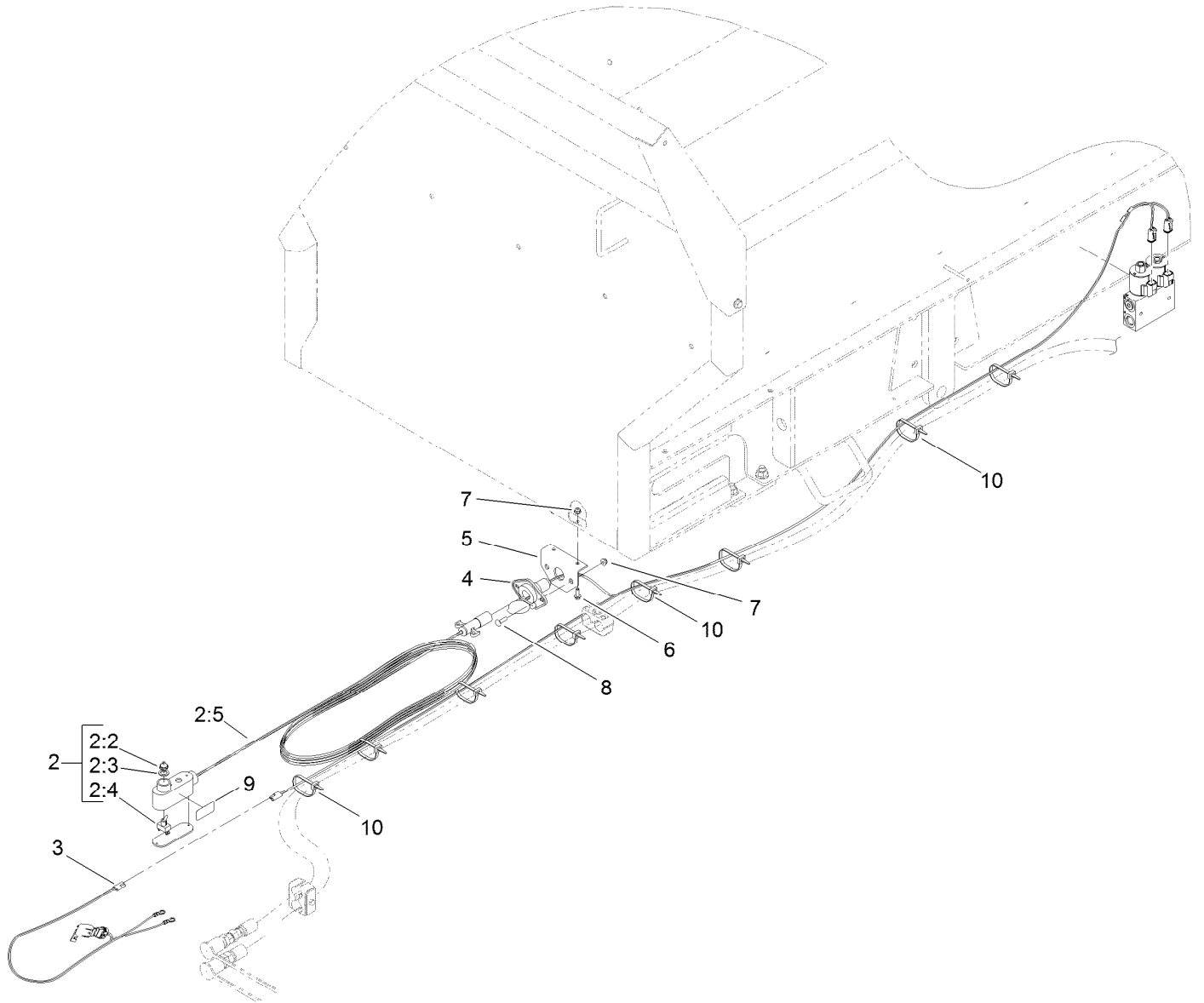

Electrical Assembly

Ref.	Part Number	Qty.	Description
2	120-0801	1	Pendant ASM
2:2	119-7554	1	Boot-Toggle Switch, Weatherproof
2:3	41-8440	1	Washer
2:4	119-7551	1	Switch-Toggle, 2-Way
2:5	120-0988	1	Harness-Wire
3	120-0852	1	Harness-Wire, Battery
4	120-0853	1	Harness-Wire, Rear
5	T36016086-01	1	Bracket-Socket
6	115-5103	2	Screw-HHF
7	104-7201	4	Nut-HF
8	3229-2	2	Screw-CARR
9	119-6822	1	Decal-Floor Conveyor
10	3290-378	10	Tie-Cable

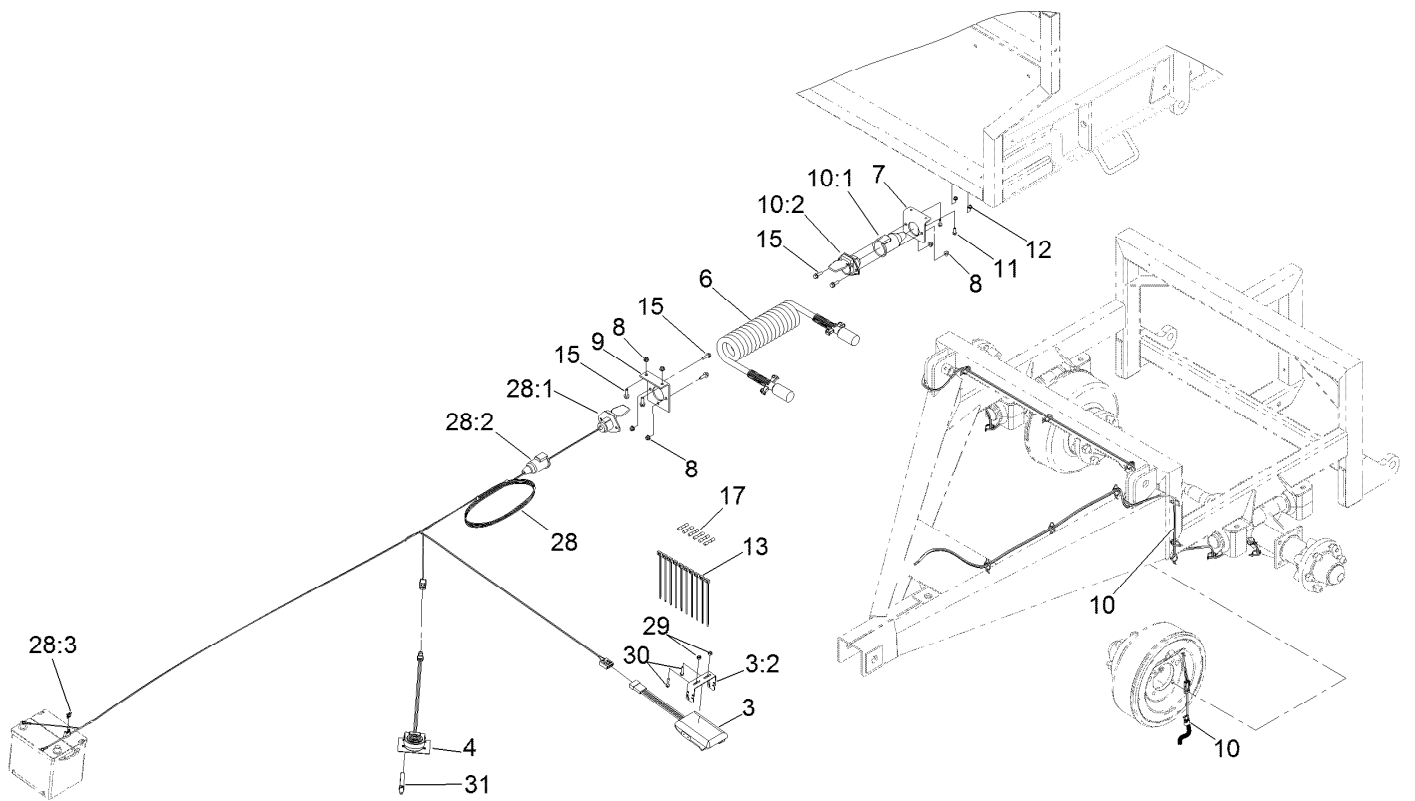

Brake Assembly

<i>Ref.</i>	<i>Part Number</i>	<i>Qty.</i>	<i>Description</i>	<i>Ref.</i>	<i>Part Number</i>	<i>Qty.</i>	<i>Description</i>
3	125-0112	1	Brake Controller	12	104-7201	2	Nut-HF
3:2	125-0114	1	Bracket-Brake Controller	13	3290-378	10	Tie-Cable
4	125-0108	1	Control-Foot,	15	3234-29	6	Screw-HHF
6	T58071132	1	Cable-Coil, 12 Ft.	17	32180-046	6	Splice-Heatshrink Covered
7	120-0892	1	Bracket-Connector	28	122-0075	1	Harness-Wire, Brake, Trailer
8	104-8300	6	Nut-Flange, NI	28:1	32160-322	1	Connector-Trailer, 7M
9	T36016080	1	Bracket-Tractor	28:2	120-0876	1	Boot-Socket
10	120-9438	1	Harness-Wire, Electric	28:3	218-578	1	Fuse-Blade, 10 Amp
10:1	120-0876	1	Boot-Socket	29	3296-2	2	Nut-Lock, NI
10:2	32160-322	1	Connector-Trailer, 7M	30	106-9169	2	Screw-HWH
11	115-5103	2	Screw-HHF	31	2412-42	1	Clamp-Hose

Notes:

Notes:

Notes:



Count on it.